

TECHNICAL MANUAL

**AVIATION UNIT AND AVIATION
INTERMEDIATE MAINTENANCE MANUAL**

CH-47D HELICOPTER

This manual together with TM 55-1520-240-23-1, TM 55-1520-240-23-2, TM 55-1520-240-23-3, TM 55-1520-240-23-4, TM 55-1520-240-23-5, TM 55-1520-240-23-7, TM 55-1520-240-23-8, TM 55-1520-240-23-9, TM 55-1520-240-23-10, TM 55-1520-240-23-11, supersedes TM 55-1520-240-23-1, TM 55-1520-240-23-2, TM 55-1520-240-23-3, TM 55-1520-240-23-4, TM 55-1520-240-23-5, TM 55-1520-240-23-7, TM 55-1520-240-23-8, TM 55-1520-240-23-9, TM 55-1520-240-23-10, 10 May 1983, and TM 55-1520-240-23-6, 6 May 1983, including all changes.

DISTRIBUTION STATEMENT A: Approved for public release; distribution is unlimited.

**CHANGE
NO. 1**

**HEADQUARTERS
DEPARTMENT OF THE ARMY
WASHINGTON, D.C., 30 SEPTEMBER 2003**

Aviation Unit and Aviation Intermediate
Maintenance Manual

CH-47 HELICOPTER

DISTRIBUTION STATEMENT A: Approved for public release; distribution is unlimited.

TM 55-1520-240-23-6, 19 September 2002, is changed as follows:

1. Remove and insert pages as indicated below. New or changed text material is indicated by a vertical bar in the margin. An illustration change is indicated by a miniature pointing hand.

Remove pages

A/(B blank)
i/(ii blank)
7-333 and 7-334
7-401 through 7-412

7-413 through 7-456
7-459 through 7-472

7-477 through 7-484
7-487 through 7-490

7-533 and 7-534
7-577 through 7-580
7-797 and 7-798

Insert Pages

A/(B blank)
i/(ii blank)
7-333 and 7-334
7-401 through 7-412
7-412.1/(7-412.2 blank)
7-413 through 7-456
7-459 through 7-472
7-472.1 through 7-472.4
7-477 through 7-484
7-487 through 7-490
7-490.1 through 7-490.4
(7-490.5 blank)/ 7-490.6
7-533 and 7-534
7-577 through 7-580
7-797 and 7-798

2. Retain this sheet in front of the manual for reference purposes.

TM 55-1520-240-23-6

C1

By Order of the Secretary of the Army:

Official:

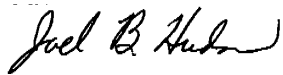

JOEL B. HUDSON

Administrative Assistant to the
Secretary of the Army

0320907

PETER J. SCHOOMAKER
General, United States Army
Chief of Staff

DISTRIBUTION

To be distributed in accordance with Initial Distribution Number (IDN) 311199, requirements for TM 55-1520-240-23-6.

WARNING AND FIRST AID DATA

For artificial respiration and other first aid data, refer to FM 21-11.

Personnel performing instructions involving operations, procedures, and practices which are included or implied in this technical manual shall observe the following instructions. Disregard of these warnings and precautionary information can cause serious injury, illness, death, or an aborted mission.

WARNING

An operating procedure, practice, etc., which if not correctly followed, could result in personal injury or loss of life.

CAUTION

An operation procedure, practice, etc., which if not strictly observed, could result in damage to or destruction of equipment.

NOTE

An operating procedure, condition, etc., which is essential to highlight.

WARNING

Cleaning Solvents

Those areas of skin and clothing that come in contact with cleaning solvents should be thoroughly washed immediately.

Saturated clothing should be removed immediately.

Areas in which cleaning solvents are used should be adequately ventilated to keep vapors to a minimum.

If cleaning solvents contact the eyes, nose, or ears, flush them with generous quantities of water, and then seek medical attention immediately.

WARNING

Electrical and Electronic Equipment Maintenance

Do not wear rings, watches, or metal jewelry when working around electrical equipment. Serious burns can result.

Be careful when working on 150 and 300 vdc circuits and on ac generator 115 and 200 vac outputs. Serious burns can result.

WARNING

Dangerous Static Charges

Ground the helicopter during parking, fueling, or defueling. Sparks can cause fuel vapor to ignite.

WARNING

Dangerous Voltages at Antenna Terminals

Be careful when working near antenna or antenna terminals. Radio frequency (rf) voltages exist at these points when transmitters are operating. Contact with radiating antennas can cause serious rf burns.

WARNING

Poisonous Carbon Monoxide Fumes

Toxic carbon monoxide fumes may be present inside the helicopter whenever engines or APU are operating with cargo ramp open. Ventilate the cockpit.

WARNING

Corrosive Battery Electrolyte (Potassium Hydroxide)

The electrolyte used in nickel-cadmium batteries contains potassium hydroxide which is a caustic substance.

Contact with skin or eyes will cause burns.

Use rubber gloves, rubber apron, and protective eye covering or face shield when handling battery.

If personal contact with electrolyte occurs, flush immediately with large amounts of only clean water. Get medical attention immediately.

WARNING

Explosive Battery Hazard

Before removing or installing battery, make sure battery switch is OFF and battery has cooled down if overheated.

Connecting or disconnecting battery connector while battery is under load may cause explosion or electrical arcing resulting in injury to personnel.

WARNING**Electrolyte Contamination**

Separate nickel-cadmium batteries and lead-acid type batteries as far as possible from each other.

Do not let anything associated with a lead-acid battery, including air, come in contact with a nickel-cadmium battery or its electrolyte. Sulfuric acid fumes from a lead-acid battery could result in damage to a nickel-cadmium battery leading to battery failure and a hazard to personnel.

Do not use same tools or protective clothing for both types of batteries.

If sulfuric acid has been somehow mixed with electrolyte in the battery, the upper areas of the battery cells will appear green in color indicating battery failure or damage and potential danger to personnel unless replaced.

WARNING**Acids and Alkalines**

Do not add water to acid. A violent action will result. Add acid to water in small quantities.

Rust stripper is an alkaline solution.

Avoid skin contact. Wear protective clothing. Wash thoroughly after using.

WARNING**Windshield Rain Repellent**

Do not let windshield rain repellent contact open flame. Deadly hydrogen fluoride gas could be generated.

Wash hands with soap and water after handling repellent.

WARNING**Antiseize Compounds**

Some antiseize compounds are irritants. Avoid inhaling fumes and contact with skin.

Wear protective clothing. Wash thoroughly after using.

WARNING

Paints, Varnishes, Dopes, Thinners, and Lubricants

These materials are generally highly flammable and may be irritants. Work in a well-ventilated area away from open flames.

Avoid inhaling fumes and prolonged contact with skin. Wash thoroughly after using.

WARNING

Epoxy Resins, Cements, and Adhesives

These materials may contain toxic or irritating substances. They may also be flammable. Work in a well-ventilated area away from open flames.

Wear protective clothing. Avoid contact with skin. Wash thoroughly after using.

WARNING

Radiation Hazard

Some instruments contain radioactive material. Do not try to disassemble these instruments. They present no radiation hazard unless seal is broken.

If you think seal is broken, do not remove instrument from helicopter before consulting Base Radioactive Protection Officer (AR 40-15).

Use a beta-gamma radiac meter AN/PDR-27 or equivalent to determine if instrument contains radioactive material (radium).

WARNING

Fire Extinguishing Agents

Monobromotrifluoromethane (CF_3Br) is highly volatile but is not easily detected by smell. It is not toxic, but reduces oxygen available for proper breathing.

If liquid CF_3Br contacts skin, it can cause frostbite or low temperature burns.

If agent touches eyes or skin, immediately flush affected area with running water. Get medical attention.

WARNING**Noise**

Sound pressure levels in this helicopter during some operating conditions exceed the Surgeon General's hearing conservation criteria (TB MED 251).

Hearing protection devices, such as aviator helmet or ear plugs, shall be worn by all personnel in and around the helicopter during operation.

WARNING**FOD**

Make sure area is clear of foreign objects before closing access doors, panels, and fairings.

If area is not clear, damage to components or systems could result in personal injury or death.

WARNING**JP-4/JP-5/JP-8 Fuel MIL-T-5624**

Fuel is flammable. Do not use near welding areas, open flames, or on very hot surfaces.

Use only with adequate ventilation.

Avoid prolonged or repeated contact with skin. Prolonged contact may cause drying and irritation of skin.

Remove saturated clothing immediately.

Do not smoke when handling fuel.

Do not take internally.

Store in approved, metal safety containers.

WARNING**Lubricating Oils MIL-L-23699 or MIL-L-7808**

If oil is decomposed by heat, toxic gases are released.

Prolonged contact with liquid or mist may cause dermatitis and irritation.

If there is prolonged contact with skin, wash affected area with soap and water. If oil contacts eyes, flush with water immediately. Remove saturated clothing.

If swallowed, do not try to vomit. Seek immediate medical attention.

When handling liquid oil, wear rubber gloves. If prolonged contact with mist is likely, wear approved respirator.

WARNING

Lifting Components With Hoist

Lifting or hoisting of components shall only be done by designated personnel.
The load capacity rating shall be clearly marked on hoist. Do not exceed load rating.
Inspection and testing for cracks or defects in hoist system shall be performed on a regular basis.
Before lifting, alert personnel in immediate areas.
Before lifting, balance the load.
Do not stand under load while it is being moved from one area to another on a hoist.
Do not stand under load to do maintenance work.

WARNING

Hydraulic Pressures

High pressures used in testing hydraulic components can cause line rupture or component failure.
Only qualified personnel shall operate, service, and maintain hydraulic test equipment.
Use heavy plastic shielding at least 5/8 inch thick when applying pressures over 250 psi to prevent injury to personnel.

WARNING

Hydraulic Fluid

Hydraulic fluid is toxic. It can irritate skin and eyes and cause burns. When fluid is decomposed by heating, it releases toxic gases.
Avoid inhaling. Use only with adequate ventilation. If prolonged contact with mist is likely, wear an appropriate respirator.
Avoid contact with skin, eyes, or clothing. Wear rubber gloves if handling liquid.
In case of contact with skin, immediately wash skin with soap and water. In case of contact with eyes, flush them immediately with clear water and get medical attention.
If liquid is swallowed, do not induce vomiting; get immediate medical attention.

WARNING

Compressed Air

Do not use more than 30 psi compressed air for cleaning purposes. Debris propelled under pressure can cause injury to eyes.

Use eye protection to prevent injury to personnel.

WARNING

Flare Dispenser

Flares can accidentally fire, sometimes from stray voltage. Injury or death can result.

Remove all electrical power from helicopter before installing loaded payload module on dispenser assembly.

Keep hands and face away from end of payload module during installation.

WARNING

Maintenance Platforms/Workstands

Use only authorized maintenance platforms/workstands or other approved locally procured stands and restraint equipment, when working above 10 feet on helicopters in a nontactical environment. Otherwise, personnel injury could result from accidental falls.

WARNING

Black Light Inspection Eyewear

Do not wear eyeglasses having light sensitive lenses while performing magnetic particle (black light) or fluorescent penetrant inspections.

Such lenses have a 16 to 45 percent light transmission loss.

Wearing them can result in failure to detect flaws and cracks under ultraviolet light.

WARNING

Cadmium-Plated Tools

Use only chrome-plated or unplated steel tools when working on the helicopter.

Cadmium or zinc-plated tools are not permitted, since these platings are prone to chipping and flaking. The chips and flakes could cause corrosion or fluid contamination.

All tools, regardless of plating type, shall be serviceable and free of chipping.

LIST OF EFFECTIVE PAGES

Insert latest changed pages; dispose of superseded pages in accordance with regulations.

NOTE: On a changed page, the portion of the text affected by the latest change is indicated by a vertical line, or other change symbol, in the outer margin of the page. Changes to illustrations are indicated by miniature pointing hands. Changes to wiring diagrams are indicated by shaded areas.

Dates of issue for original and changed pages are:

Original 19 September 2002
Change 1 30 September 2003

Page No.	*Change No.	Page No.	*Change No.
Title	0	7-472.3 added	1
a through g	0	7-472.4 added	1
h blank	0	7-473 through 7-476	0
A	1	7-477 through 7-480	1
B blank	1	7-481	0
i	1	7-482 through 7-484	1
ii blank	1	7-485 and 7-486	0
7-1 through 7-11	0	7-487 and 7-488	1
7-12 blank	0	7-489	0
7-13 through 7-332	0	7-490	1
7-333	1	7-490.1 added	1
7-334 through 7-401	0	7-490.2 added	1
7-402	1	7-490.3 added	1
7-403	0	7-490.4 added	1
7-404 through 7-412	1	7-490.5 blank added	1
7-412.1 added	1	7-490.6 added	1
7-412.2 blank added	1	7-491 through 7-532	0
7-413 through 7-423	1	7-533 and 7-534	1
7-424 and 7-425	0	7-535 through 7-577	0
7-426	1	7-578 and 7-579	1
7-427 through 7-456	1	7-580 through 7-605	0
7-457 through 7-459	0	7-606 blank	0
7-460 and 7-461	1	7-607 through 7-623	0
7-462	0	7-624 blank	0
7-463	1	7-625 through 7-796	0
7-464	0	7-797 and 7-798	1
7-465 through 7-471	1	7-799 through 7-1299 ...	0
7-472	0	7-1300 blank	0
7-472.1 added	1		
7-472.2 added	1		

*Zero in this column indicates an original page.

**AVIATION UNIT AND AVIATION
INTERMEDIATE MAINTENANCE MANUAL
CH-47D HELICOPTER**

REPORTING ERRORS AND RECOMMENDING IMPROVEMENTS

You can improve this manual. If you find any mistakes or if you know of a way to improve these procedures, please let us know. Mail your letter or DA Form 2028 (Recommended Changes to Publications and Blank Forms) located in the back of this manual, directly to: Commander, U.S. Army Aviation and Missile Command, ATTN: AMSAM-MMC-MA-NP, Redstone Arsenal, AL 35898-5000. A reply will be furnished to you. You may also provide DA Form 2028 information to AMCOM via e-mail, fax, or the World Wide Web. Our fax number is: DSN 788-6546 or Commercial 256-842-6546. Our e-mail address is: 2028@redstone.army.mil. Instructions for sending an electronic 2028 may be found at the back of this manual immediately preceding the hard copy 2028. For the World Wide Web use: <https://amcom2028.redstone.army.mil>.

DISTRIBUTION STATEMENT A: Approved for public release; distribution is unlimited.

TABLE OF CONTENTS

		PAGE NO.
VOLUME	VI	
CHAPTER	7 HYDRAULIC SYSTEM	7-1
Section	I Flight Control Hydraulic System Description and Theory of Operation	7-1
Section	II Flight Control Hydraulic System	7-13
Section	III Utility Hydraulic System Description and Theory of Operation	7-607
Section	IV Utility Hydraulic System	7-625
INDEX	See Volume XI	

*This manual together with TM 55-1520-240-23-1, TM 55-1520-240-23-2, TM 55-1520-240-23-3, TM 55-1520-240-23-4, TM 55-1520-240-23-5, TM 55-1520-240-23-7, TM 55-1520-240-23-8, TM 55-1520-240-23-9, TM 55-1520-240-23-10, TM 55-1520-240-23-11, supersedes TM 55-1520-240-23-1, TM 55-1520-240-23-2, TM 55-1520-240-23-3, TM 55-1520-240-23-4, TM 55-1520-240-23-5, TM 55-1520-240-23-7, TM 55-1520-240-23-8, TM 55-1520-240-23-9, TM 55-1520-240-23-10, 10 May 1983, and TM 55-1520-240-23-6, 6 May 1983, including all changes.

CHAPTER 7

HYDRAULIC SYSTEM

SECTION I

FLIGHT CONTROL HYDRAULIC SYSTEM DESCRIPTION AND THEORY OF OPERATION

DESCRIPTION

The flight control hydraulic system consists of two identical but independent systems, identified as No. 1 and No. 2. They provide hydraulic assistance for operation of flight controls. The systems are parallel in operation, hydraulically separated, and electrically integrated. Each system operates at about **3,000 psi** hydraulic pressure. If one system fails, the flight controls can still be operated on the boost pressure provided by the other system.

Both systems can be operated by an external power source through external power connections. Connections for the No. 1 system are at the forward left side of the helicopter. Connections for the No. 2 system are at the aft right side. The system can also be powered by the auxiliary power unit when the engines are shut down.

In general, components of the No. 1 system are located in the forward fairing. No. 2 system components are in the aft pylon. The following components are common to both systems.

Fill Module

Hydraulic fluid is added to both systems through a fill module at the right side of the cabin in the ramp area. The same module is also used to fill the utility hydraulic

system. All hydraulic systems may be serviced either static or while system is operating. Selection of the system to be serviced is by a rotary valve on the module.

Fluid added to the module is pulled through the fill cannister and into the selected system by operating a small hand pump on the module.

Hydraulic Panel

A three-position switch is on the HYDRAULIC panel in the cockpit overhead panel. The switch is marked FLT CONTR, with switch positions of NO. 1 ON, BOTH, and NO. 2 ON. At BOTH, the two systems work together to provide boost to the controls. Turning the switch to either of the individual systems disables and isolates the opposite system.

There are two PWR XFR switches on the panel, one for each system. If the engines are shut down, and the auxiliary powerplant is running, either or both of the flight control systems can be pressurized by turning the appropriate switch to ON.

Maintenance Panel

A maintenance panel is mounted on the right side of the cabin in the ramp area. The panel contains a HYDRAULICS section that has gages and indicator lights for various system parameters.

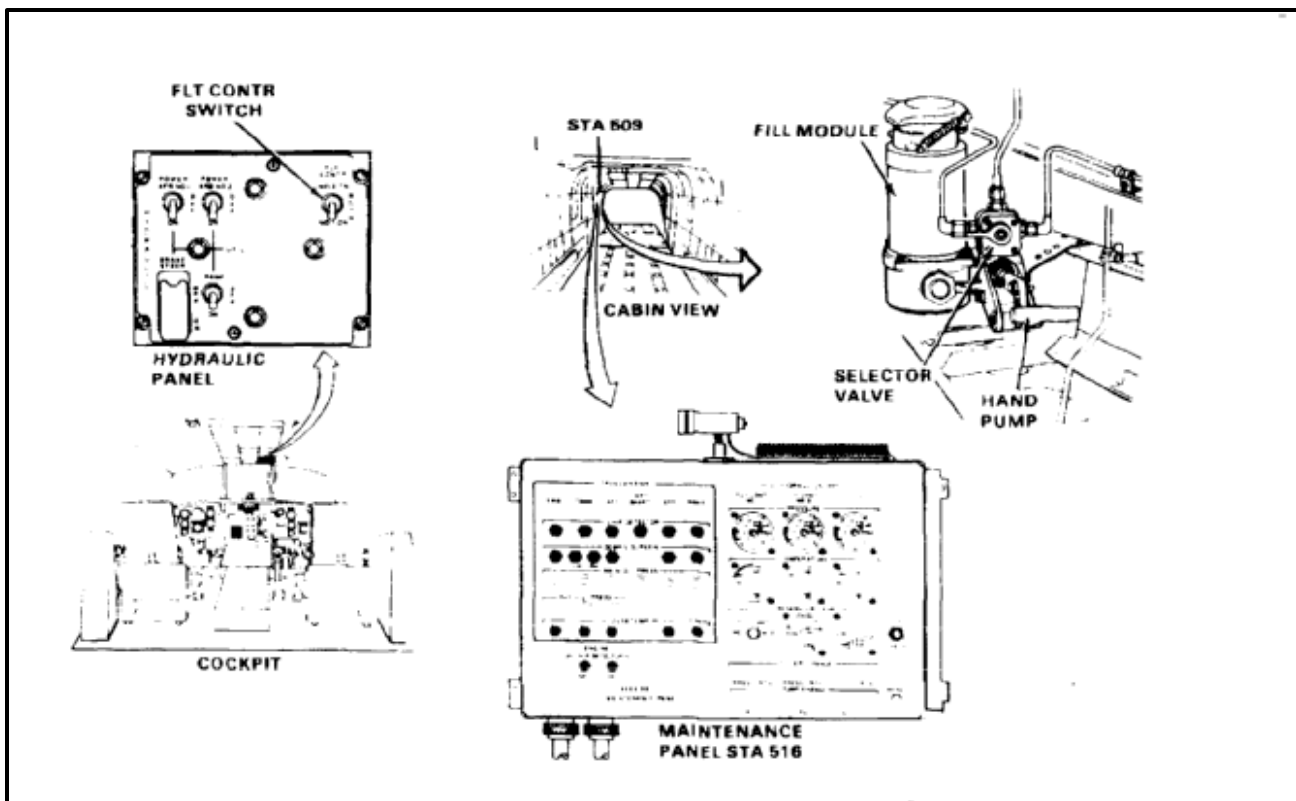

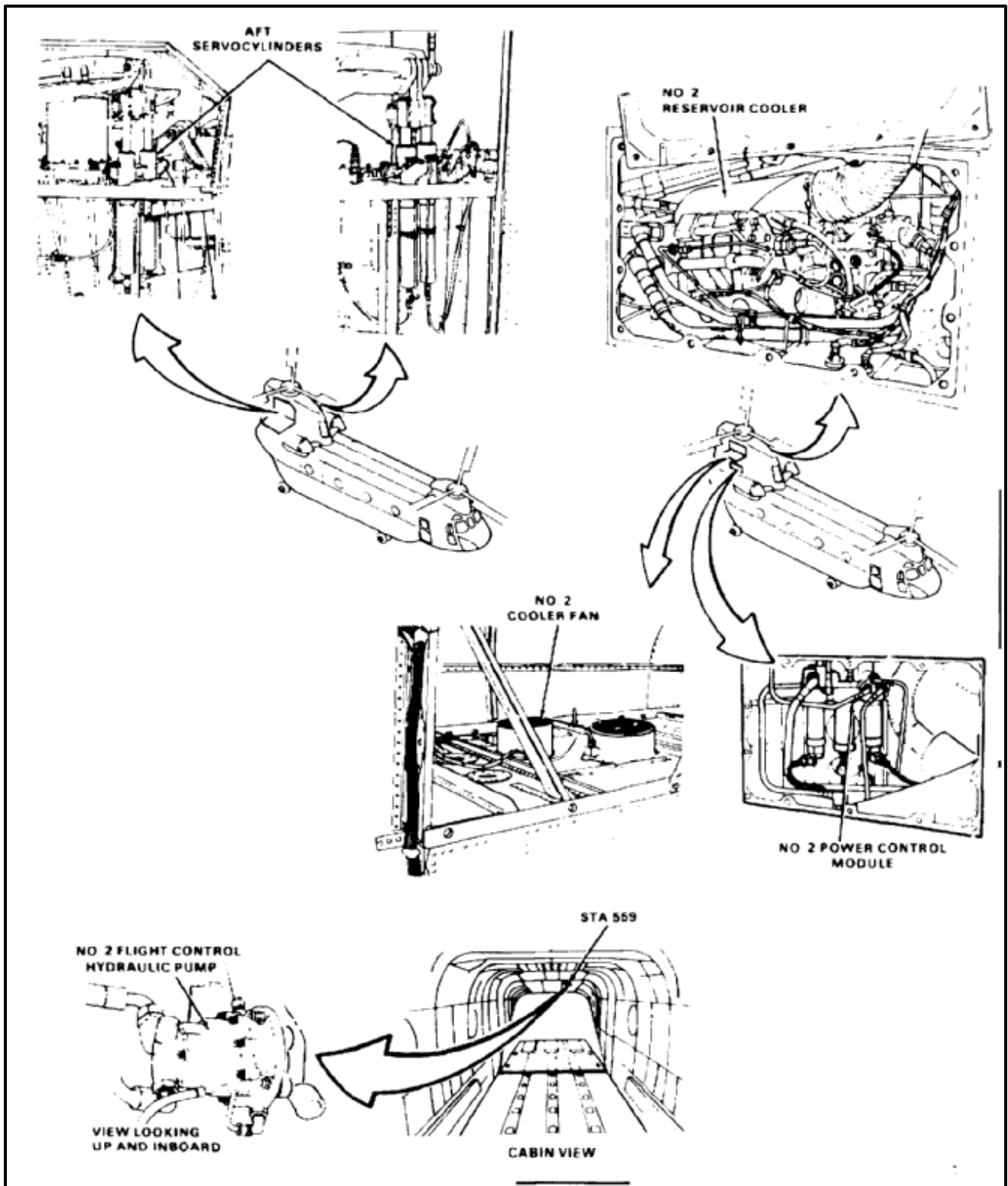

Hydraulic Pump

A variable delivery pump supplies **3,000 psi** hydraulic pressure at a flow rate of **15 gpm** to each flight control system. The No. 1 system pump is driven by the forward transmission, and is accessible from the passageway. The pump for the No. 2 system is driven by the aft transmission. It is accessible from the ramp.

There are four ports in each pump: inlet, outlet, seal drain (SD), and case drain (CD). Both pumps are identical and interchangeable, with each other and with the utility system hydraulic pump on the aft transmission.

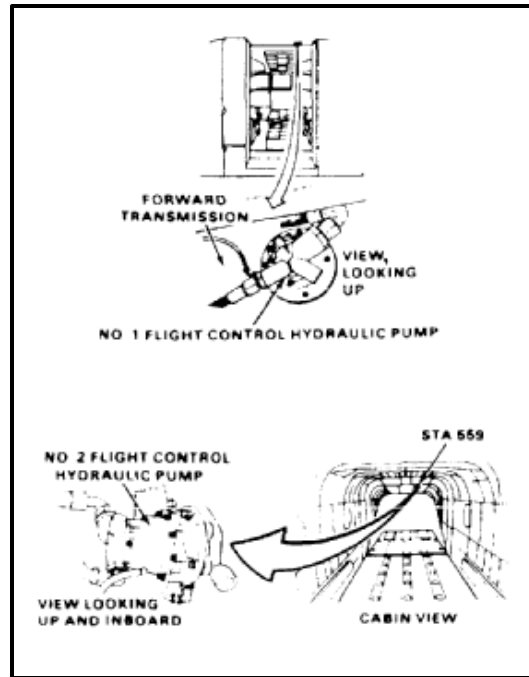

Power Control Module

Each power control module (PCM) controls the flow of all pressure and return fluid through its flight control hydraulic system. The No. 1 module is located in the forward transmission fairing, aft of the transmission. The module for the No. 2 system is in the aft pylon, at the right side.

Each module has ten major components: pressure and return filters and indicators; four different valves, a pressure switch and transmitter, a pump change indicator, and an accumulator. All of the components are installed in a manifold. The accumulator dampens low frequency pressure surges and provides stored hydraulic power for peak loads.

Functions of the PCM's are to direct pressure and flow to either #1 or #2 flight boost system.

- Operates on **3000 psi** at **7-8 GPM**
- Electrical power from #2 DC bus **28 vdc**
- Controlled by boost select switch on overhead panel in cockpit
- Weight **17.2 pounds** dry

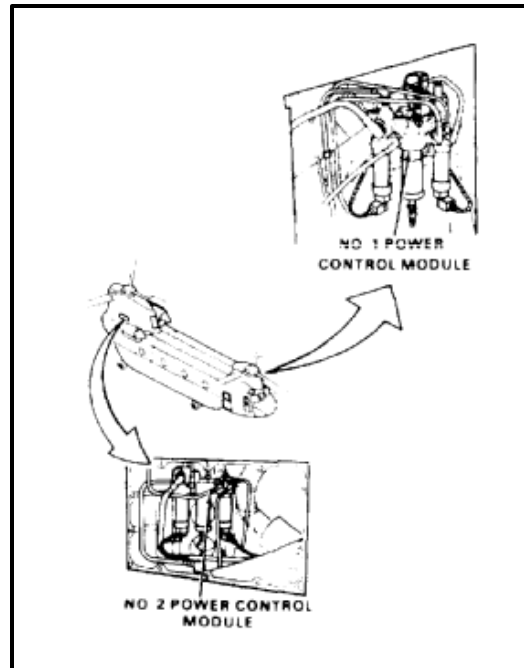

Power Transfer Unit

A power transfer unit (PTU) in each hydraulic system allows boost to be applied to the flight controls when the drive system is shut down. Each PTU consists of a pump driven by a hydraulic motor. The motor is hydraulically powered by the auxiliary power unit motor pump, utility hydraulic pump or ground support equipment. It drives the pump through splined coupling to supply hydraulic pressure of **3,000 psi at 3.5 gpm** to the controls.

The No. 1 PTU is in the forward transmission fairing, aft and right of the forward transmission. The No. 2 PTU is in the aft pylon, on the left side.

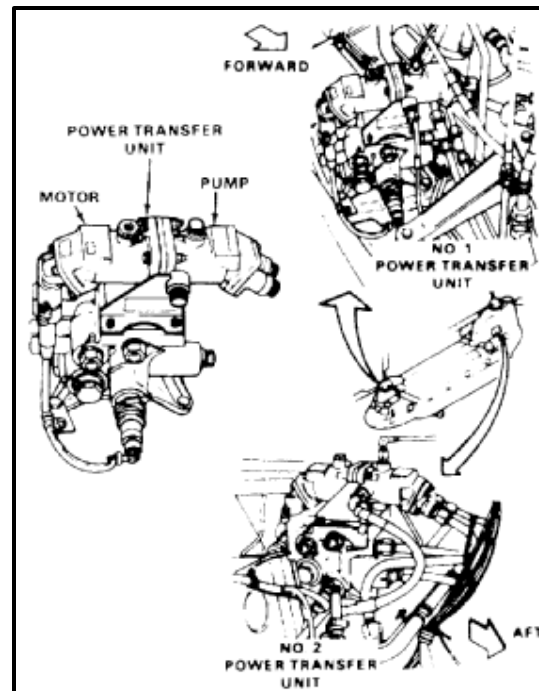

Servocylinders

A pivoting and a swiveling servocylinder are installed at each rotor head. At the forward head, lower (fixed) part of each servocylinder is mounted on the forward transmission and the upper (movable) part is attached to the forward swashplate stationary ring. At the aft head, the lower part is mounted to aft pylon structure. The upper part is attached to the aft swashplate stationary ring. Each servocylinder receives **3,000 psi** boost pressure from each flight control system. The pressure lifts dual pistons, raising the swashplate on the rotor shaft. Each servocylinder has individual manifolds and cylinders for each of the hydraulic systems.

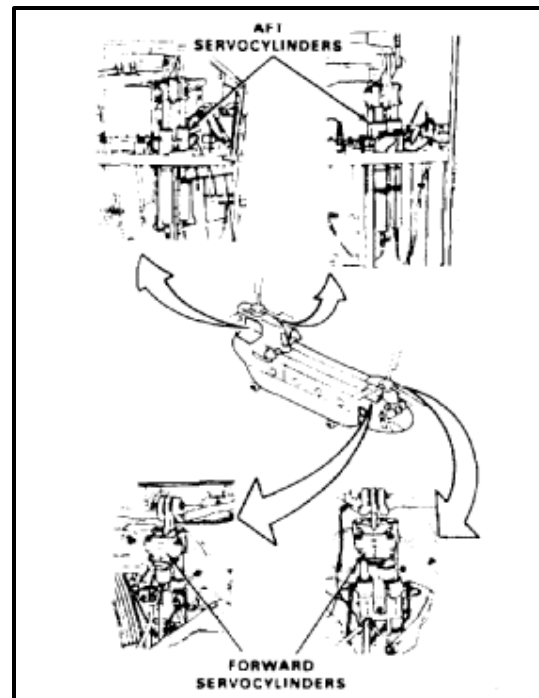

Reservoir Cooler

Fluid storage and cooling for each system is provided by an integrated reservoir cooler module with a separate fan. The reservoir section of the module stores fluid for system operation. The cooler is mounted on top of the reservoir. It is connected by flexible ducting to a fan that is activated by a thermal switch in the cooler. Sensors in the unit send information on fluid level and temperature to the maintenance panel in the ramp area. An indicating rod on the reservoir provides another indication of system fluid level.

The reservoir cooler and fan for the No. 1 system are in the forward fairing, aft of the forward transmission. The No. 2 system module is in the aft pylon on the left side.

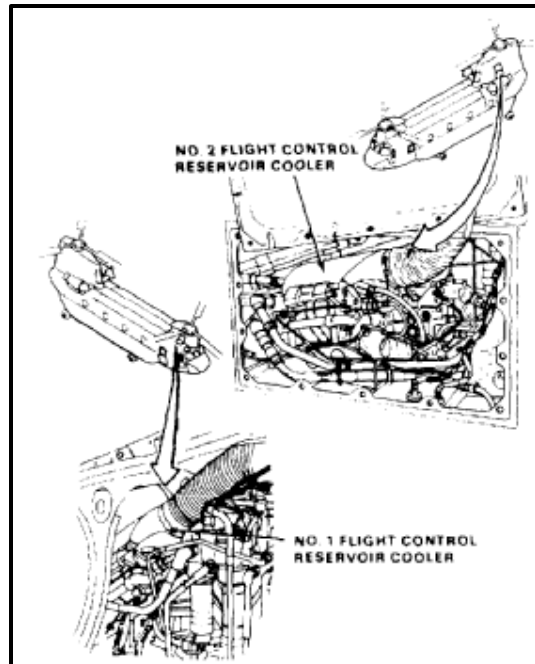

Lower Controls Modules

A lower controls module in each system reduces hydraulic pressure to the integrated lower controls actuators (ILCA) from **3,000 to 1,500 psi**.

A solenoid valve in each module shuts off hydraulic pressure to the AFCS extensible links in each ILCA. It is actuated by either manual or automatic shutdown of the AFCS.

The modules for both systems are located in the upper part of the flight controls closet. The No. 1 system module is at sta. 100. The No. 2 module is at sta. 95.

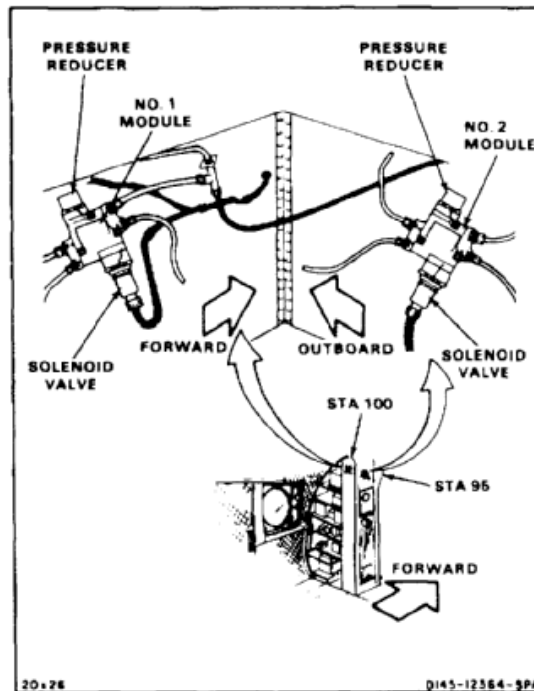

Integrated Lower Control Actuators

Four integrated lower control actuators (ILCA) are in the flight controls closet between sta. 95 and 120. The actuators operate on **1,500 psi** hydraulic pressure to provide cockpit control boost in the pitch, roll, yaw, and thrust axes and advanced flight control system (AFCS) augmentation in the pitch, roll, and yaw axes. The actuators are similar, but not directly interchangeable unless the authority covers are transferred because the actuators are assembled for the particular flight axis in which they are installed.

Each ILCA assembly has two independent boost actuator systems and two AFCS extensible links. Both systems are mounted together but operate independently of each other. System No. 1 is the upper half and system No. 2 is the lower half. Each extensible link has a servo valve, relief valve, jam sensors, and self feedback transducers. The thrust ILCA does not have an AFCS extensible link, although it has two independent boost actuator systems.

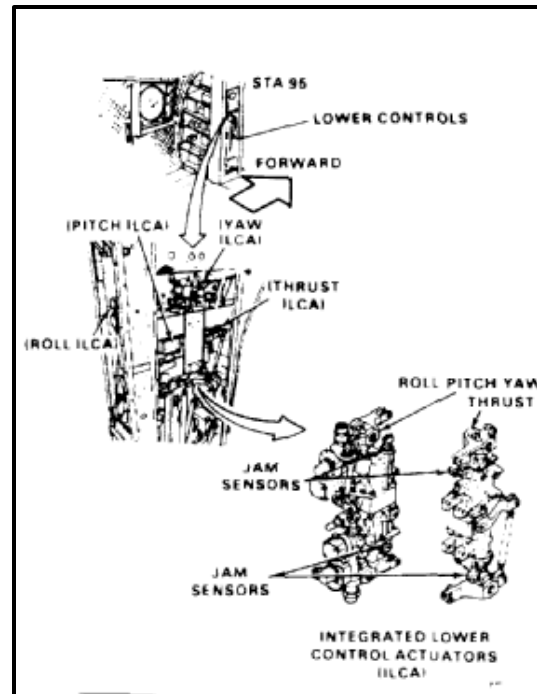

THEORY OF OPERATION

Both flight control hydraulic systems work in the same manner. Hydraulic fluid pressurized to **3,000 psi** leaves the power source (transmission-driven pump, PTU pump, or ground power unit) and enters the power control module. In the module, it passes through a monitored filter, pressurizes an accumulator, and flows through a pressure-operated valve out of the module.

From the module, the fluid flows to pressurize the pivoting and swiveling servocylinders at each rotor head. It then enters the lower controls system module in the flight controls closet area.

The lower controls module contains a pressure reducer that drops line pressure from **3,000 to 1,500 psi**. A return line carries excess fluid back to the power control module. Fluid exits the module at **1,500 psi** through two ports. An upper port leads to the ILCA manifold to provide boost for the lower controls. The lower port leads to the AFCS extensible link port in the manifold.

Pressurized fluid from both hydraulic systems enters a two-piece ILCA manifold. Four ILCAs are mounted on the manifold. The two that boost pitch and roll control inputs are on one side. Those that boost yaw and thrust inputs are on the other side.

The upper half of each manifold supplies fluid to all ILCAs from the No. 1 system. The lower half supplies fluid from the No. 2 system. Because the thrust ILCA does not have an extensible link, fluid from the lower port of the lower controls module is not directed to that actuator.

Like the manifold, each ILCA is split into two halves. The top half is pressurized by the No. 1 hydraulic system,

the bottom half by the No. 2 system. Check valves in the manifold prevent fluid loss when an ILCA is removed.

When AFCS is switched off, a solenoid valve in each lower controls module closes off fluid flow to the extensible link controls in the ILCA. In this mode, all four ILCAs act in the same manner. Pilot input displaces a control valve in the ILCA, routing hydraulic fluid to an internal actuator piston. The piston extends or retracts and the motion is transferred to the upper controls.

When AFCS is switched on, the solenoid valve in the lower controls module opens and pressurized fluid activates the extensible link on each of the three ILCAs so equipped. Servo valves on the ILCA respond to input from the AFCS computers to move the link. The motion is transferred directly to the output link of the ILCA moving the upper controls independently of input link motion.

Low pressure return fluid leaving each ILCA is routed through ports in the manifold and a return line to a return port in the power control module. It passes through a monitored return filter and out of the module.

If the power source is the flight control pump or the power transfer unit, fluid leaving the module is circulated through the reservoir cooler before being discharged to the power source. A thermal switch in the discharge port of the reservoir cooler turns on a cooling fan when fluid temperature reaches about **145°F**. When fluid temperature drops to about **130°F**, the switch turns the fan off.

If the power source is an external ground power unit, fluid leaving the module is discharged directly to the unit.

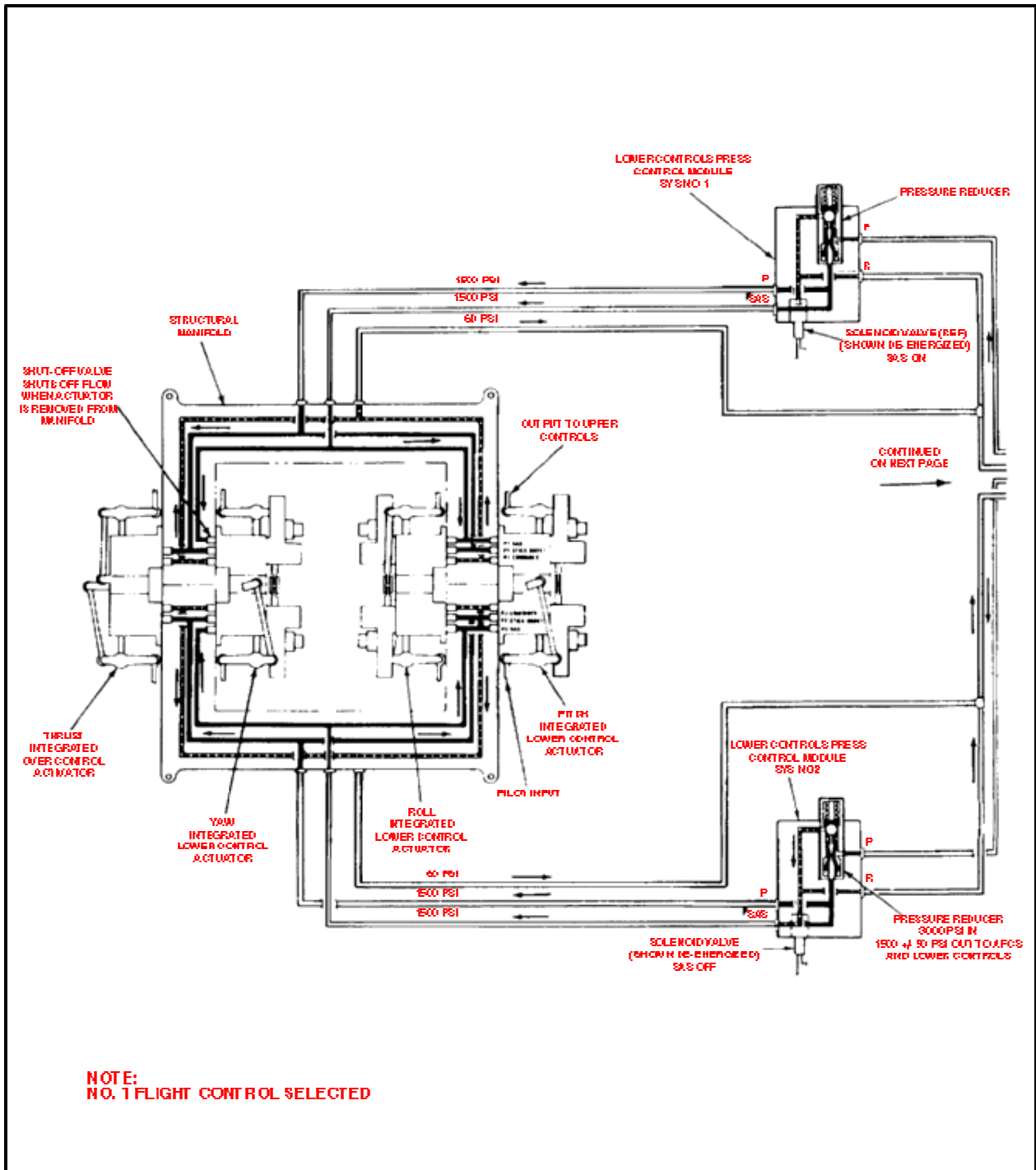

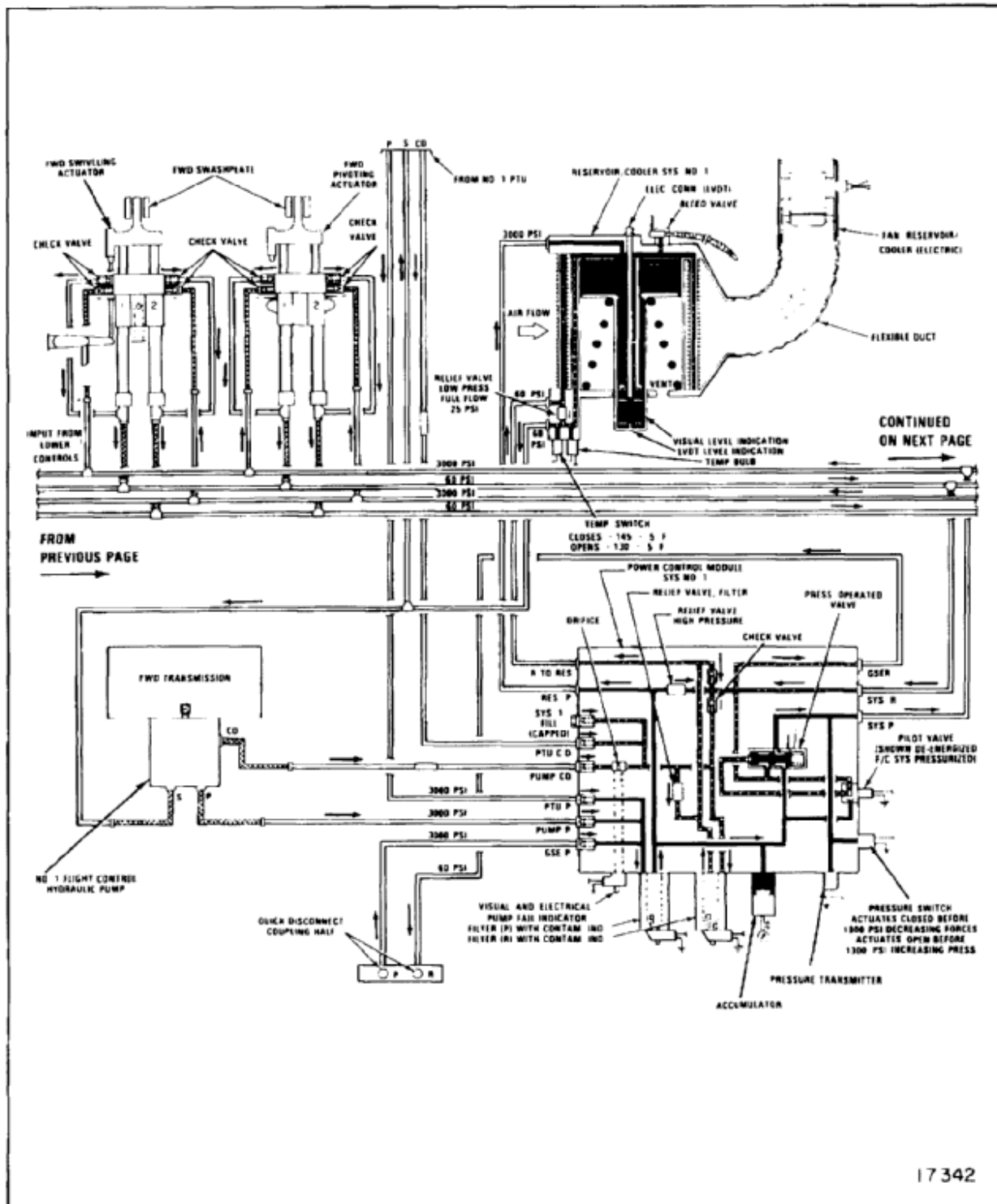

17342

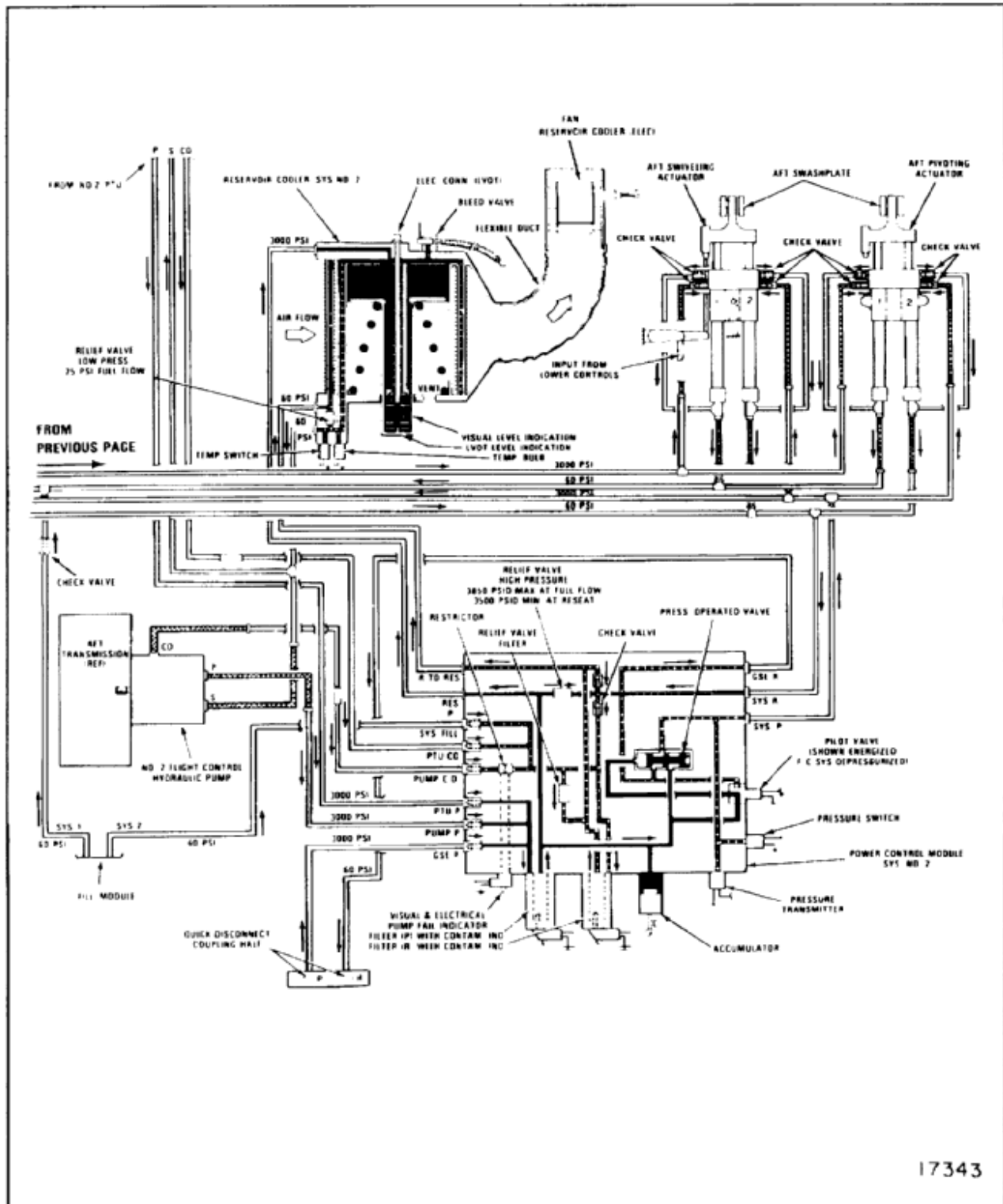

17343

END OF TASK

7-11/(7-12 blank)

SECTION II
FLIGHT CONTROL HYDRAULIC SYSTEM

7-1.1 GENERAL INSPECTION OF HYDRAULIC SYSTEM COMPONENTS (GENERAL INFORMATION)

7-1.1

INITIAL SETUP**Applicable Configurations:**

All

Tools:

Technical Inspection Tool Kit, NSN 5180-00-323-5114

Materials:

None

Personnel Required:

Inspector

References:

TM 43-0105

TM 43-0139

TM 1-1520-253-23

Equipment Condition:

Off Helicopter Task

EXTERIOR SURFACES**Negligible damage**

Minor scratches (without burrs or raised material) that do not penetrate through the protective finish are acceptable as is without rework.

Reparable damage

Nicks, gouges, corrosion pits (TM 43-0105) or other minor surface damage that does not exceed a depth of **10 percent or 0.040 inch** of material thickness, whichever is less after rework, are permissible.

No burnishing is allowed within **0.75 inch** of a bolt hole or in a corner.

Thread damage is limited to one thread with **50 percent** damage.

No cracks are allowed. If a crack in the reservoirs/coolers, accumulators, power transfer unit, or hydraulic pump casings is suspected, refer to TM 1-1520-253-23.

No mating or working surface repair is allowed.

Touch up removed protective finish as required (TM 43-0139).

Replacement damage

Damage exceeding negligible and reparable limits, or damage which occurs on an oil seal surface, radius, within a hole, or on a mating or working surface of a part necessitates replacement.

INTERNAL PARTS

Repair is limited to removal of minor burrs, nicks, or scratches with abrasive cloth on nonworking and nonmating surfaces. No repair of working or mating surfaces is allowed.



Do not use crocus abrasive cloth (E122) on aluminum parts. This cloth contains an oxide of iron which causes rapid corrosion of aluminum. Use aluminum oxide or silicon carbide paper for aluminum parts. Use crocus cloth for steel parts.

FOLLOW-ON MAINTENANCE:

None

END OF TASK

7-2 INSPECT HYDRAULIC SYSTEM PLUMBING (GENERAL INFORMATION)

7-2

INITIAL SETUP**Applicable Configurations:**

All

Tools:

Hydraulic Repairer's Tool Kit, NSN 5180-00-323-4891
 Inspector's Tool Kit, NSN 5180-00-323-5114

Personnel Required:

Aircraft Pneudraulics Repairer
 Inspector

References:

Task 7-3
 Task 7-5
 TM 1-1500-204-23

Equipment Condition:

Battery Disconnected (Task 1-39)
 Electrical Power Off
 Hydraulic Power Off
 Access Panels and Work Platforms Open, As
 Required (Task 2-2)

1. Refer to TM 1-1500-204-23 for wear and damage limits on tubes, hoses, and fittings.
2. Inspect for chafed, cracked, dented, nicked, and scored tubes. Replace damaged or worn tubing (Tasks 7-3 and 7-5).
3. Inspect rubber fairleads, especially in drive shaft tunnel area and under combining transmission. Inspect for security, wear and cracks which can cause chafed and cracked tubing. Replace cracked or worn fairleads. Replace worn, cracked or chafed tubing (Tasks 7-3 and 7-5).
4. Inspect for loose, broken, and cracked clamps. Replace damaged clamps.
5. Inspect for chafed, deteriorated, cut, frayed, and cracked hoses. Replace damaged or worn hoses (Tasks 7-3 and 7-5).
6. When plumbing is disconnected, inspect fittings for crossed, burred, and stripped threads. Replace as necessary (Tasks 7-3 and 7-5). Cap or plug all disconnected fittings.

FOLLOW-ON MAINTENANCE:

Closed access panels and work platforms, as required (Task 2-2).

END OF TASK

INITIAL SETUP

Applicable Configurations:

All

Tools:

Hydraulic Repairer's Tool Kit, NSN 51 80-00-323-4891
Containers

Materials:

Cloths (E120)
Tags (E264)

Parts:

Caps
Plugs

Personnel Required:

Aircraft Pneudraulics Repairer

References:

TM 1-1500-204-23
Task 1-64
Task 1-65

Equipment Condition:

Battery Disconnected (Task 1-39)
Electrical Power Off
Hydraulic Power Off
Access Panels and Work Platforms Open As
Required (Task 2-2)

General Safety Instructions:

As Required

NOTE

When removing fittings, hoses, or tubes, use following information as a guide.

WARNING

Deplete hydraulic pressure in system before disconnecting any fitting. Hydraulic fluid ejected under pressure can cause injury to personnel. Hydraulic fluid spray is a fire hazard.

1. If removing item from flight control system, deplete pressure by cycling cockpit control stick (Task 1-64).
2. If removing item from utility system, deplete pressure by pressing APU start module depressurization valve (Task 1-65).
- 2.1. Cover the dash actuators if work is to be performed in the flight control closet. Hydraulic fluid can enter actuator motor, making it inoperative.

REMOVAL OF FITTINGS

3. Note position and location of all fittings to be removed.
4. Place containers and cloths (E120) to catch and absorb fluid that drains during removal.
5. Remove fittings as required. Install plugs in ports. Install caps in open ends of lines.
6. Replace all packings and seals on fittings to be used again.

REMOVAL OF HOSES

7. Identify ends of lines, hoses, or tubes before disconnecting.
8. Place containers and cloths (E120) to catch and absorb fluid that drains during removal.
9. Hold hose fittings with wrench. Disconnect hoses as required. Install plugs or caps as required on open connections of components or lines.
10. Remove all clamps and tag hose to indicate exact location. Use paper tags (E264). Remove hose.



Teflon hoses may remain in installed shape after removal. Straightening will damage this type of hose.

11. Do not try to straighten bends in hose.

NOTE

When handling hose, refer to TM 1-1500-204-23.

12. Deleted.

REMOVAL OF TUBES

13. Place containers and cloths (E120) to catch and absorb fluid that drains during removal.
14. Disconnect tubes as required. Install plugs or caps as required on open connections of components or lines.
15. Remove clamps and fittings as required. Remove tube. Set aside clamps and fittings to be used again.

FOLLOW-ON MAINTENANCE:

Install hydraulic system plumbing (Task 7-4).
Close access panels and work platforms (Task 2-2).

INITIAL SETUP

Applicable Configurations:

All

Tools:

Hydraulic Repairer's Tool Kit, NSN 5180-00-323-4891
 Inspector's Tool Kit, NSN 5180-00-323-5114
 Containers
 Low Pressure Compressed Air Source

Materials:

Cloths (E120)
 Hydraulic Fluid (E199)
 Teflon Tape (E398)

NOTE

When installing hydraulic fittings, hoses or tubes, use following information as a guide.

INSTALLATION OF FITTINGS

1. Place containers and cloths (E120) to catch and absorb fluid that drains during installation.
2. Clear fittings with low pressure compressed air.
3. Inspect threads for burrs or stripping.
4. Coat all seals, packings, and threads with clean hydraulic fluid (E199).
5. Install all new packings, seals, or gaskets.
6. Align fittings with lines before final tightening.

INSTALLATION OF HOSES

7. Place containers and cloths (E120) to catch and absorb fluid that drains during installation.
8. Clear hoses with low pressure compressed air.
9. Inspect threads for burrs or stripping.

Parts:

Packings
 Seals
 Gaskets

Personnel Required:

Aircraft Pneudraulics Repairer
 Inspector

References:

Task 1-13
 TM 1-1500-204-23

10. Inspect that hoses are not frayed, cut, worn, or weather-cracked.



Straightening a bend in a used hose may damage hose.

NOTE

Do not try to straighten bends in hose. Use hose so bends fit location (TM 1-1500-204-23).

11. Deleted.
12. Make sure hoses do not twist when tightening end fittings or nuts.
13. Make sure hose is free to follow movement of components. Make sure hose has no bends that restrict fluid flow.
14. Spiral wrap all areas on hoses where chafing can occur. Use Teflon tape (E398).
15. Make sure hoses are properly anchored to prevent chafing.
16. Torque hose end fittings (Task 1-13).

7-4 INSTALL HYDRAULIC SYSTEM PLUMBING (GENERAL INFORMATION) (Continued)

7-4

INSTALLATION OF TUBES

17. Place containers and cloths (E120) to catch and absorb fluid that drains during installation.
18. Clear tubes with low pressure compressed air.
19. Inspect tubes for nicks, dents, and deep scratches.
20. Do not pull tubes into position by tightening nuts. Position tubes properly between connecting points to avoid stressing.
21. Do not bend installed tubes. Remove tubes and bend to proper configuration with proper tools.
22. Torque tube nuts (Task 1-13).
23. Anchor tubes properly to prevent chafing.
24. Plug all open ends if tubes will not be connected immediately.

FOLLOW-ON MAINTENANCE:

- Flush hydraulic system (Refer to Index).
- Fill and bleed hydraulic system (Refer to Index).
- Close access panels and work platforms (Task 2-2).

END OF TASK

INITIAL SETUP

Applicable Configurations:

All

Tools:

Hydraulic Repairer's Tool Kit, NSN 51 80-00-323-4891

Materials:

None

Parts:

Washers

Personnel Required:

Aircraft Pneudraulics Repairer

Inspector

References:

TM 55-1520-240-23P

Task 1-13



Aluminum washers must be used against aluminum structure. Steel washers must be used against steel structure. Otherwise, damage to components can occur.

STYLE "S" FITTING (MS21908)

1. Install washer (1) on fitting (2) against shoulder of hose (3).
2. Position fitting (2) in structure (4). Install washer (5) on fitting (2).
3. Install nut (6) on fitting (2). Torque nut (Task 1-13).

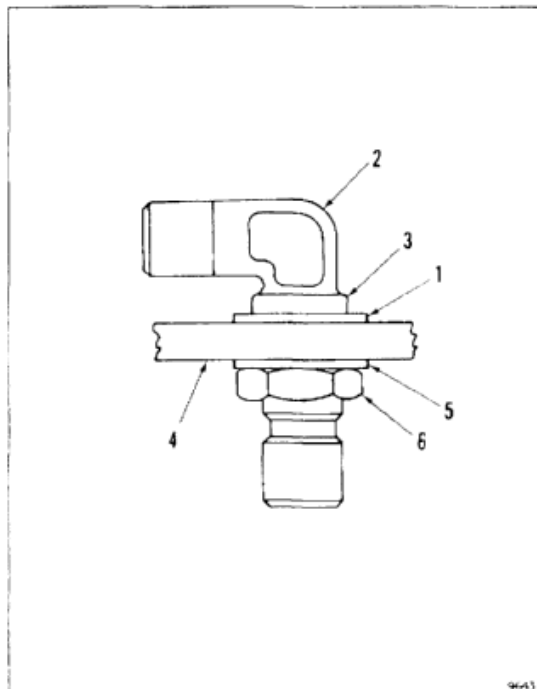

7-4.1 INSTALL HYDRAULIC SYSTEM BULKHEAD FITTINGS (GENERAL INFORMATION) (Continued)

7-4.1

STYLE "S" (MS21924) BULKHEAD UNION

4. Position fitting (7) in structure (8).
5. Install washer (9) and nut (10) on fitting (7). Torque nut (Task 1-13).

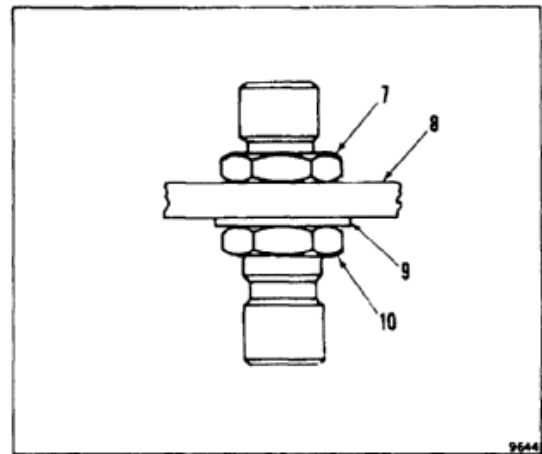
**PERMASWAGE FITTING (D10019)**

6. Position fitting (11) in structure (12).
7. Install washer (13) and nut (14) on fitting (11). Torque nut (Task 1-13).

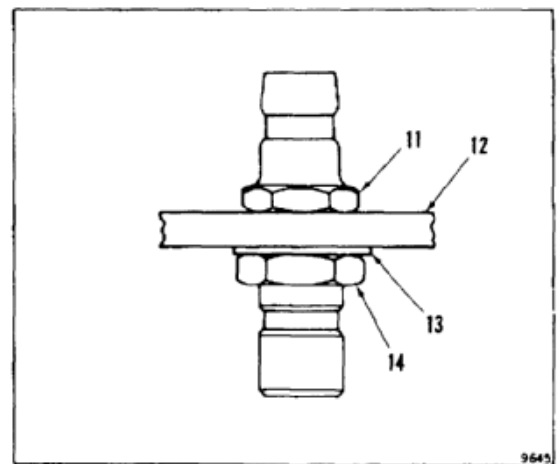
INSPECT**FOLLOW-ON MAINTENANCE:**

- Fill and bleed hydraulic system (Task 7-16).
- Close access panels and work platforms (Task 2-2).

END OF TASK

INITIAL SETUP

Applicable Configurations:

All

Tools:

- Bender Tube Hand, P/N 130-8500800
- Hydraulic Repairer's Tool Kit, NSN 5180-01-323-4891
- Tube Repair Kit, As Required, NSN 5180-01-026-0253
- Tube Repair Kit, As Required, NSN 5180-01-026-0255
- Tube Repair Kit, As Required, NSN 5180-01-026-0254
- Goggles
- Source of Compressed Air
- Micrometer

Materials:

- Solvent (E161)
- Marking Pencil (E271)

Parts:

- Corrosion Resistant Steel Tube MIL-T-6845 (304 1/8 Hard) (APP E-50)
- Aluminum Alloy Tube MIL-T-7081 (6061-T6) (APP E-50)

Personnel Required:

- Aircraft Pnedraulics Repairer
- Inspector

References:

- Task 7-5
- TM 55-1520-240-23P
- Appendix E

Equipment Condition:

- Off Helicopter Task

General Safety Instructions:

WARNING

Assembly of this part shall not permit the use of cleaning solvents containing halogens in excessive amounts. The maximum permissible level of chlorine is **200 ppm** total as measured by the X-ray fluorescence method or equivalent. The maximum level of water allowed is **150 ppm**.

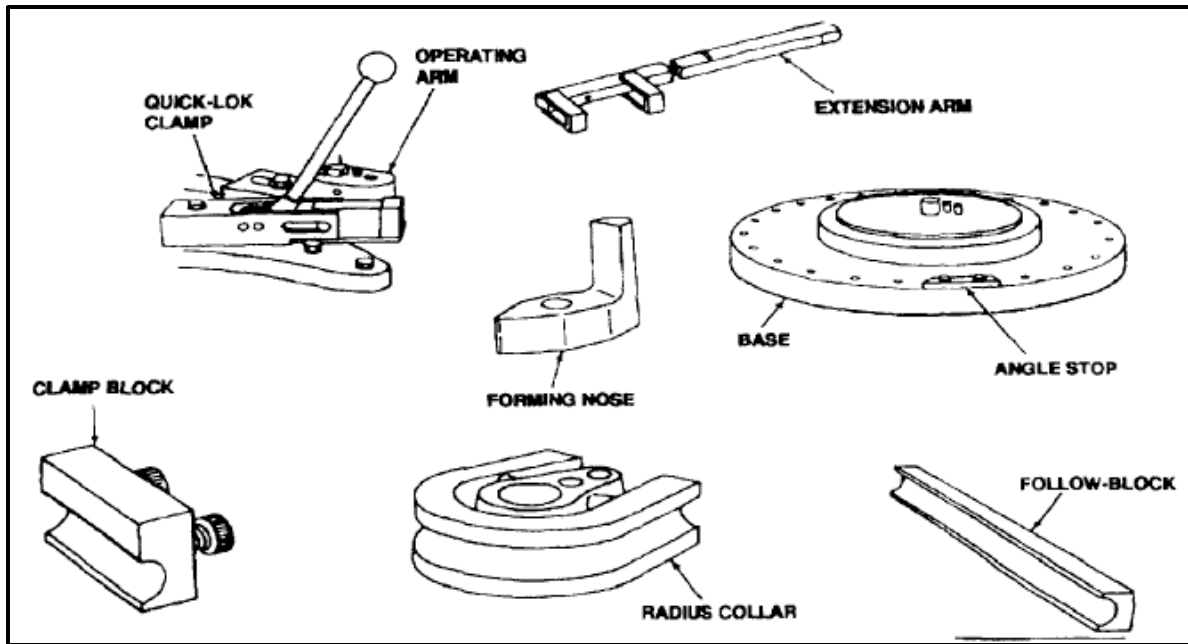

CAUTION

Tube ends shall be square to tube centerline. OD of tube shall be free of scratches **1-1/2 inches** from tube ends to ensure leak-proof swage at end fittings.

NOTE

If desired, tube may be cut oversize and trimmed to desired length after bending.

1. Cut tube (1) to required length (APP E-50, chart A) (Task 7-5). If tube is cut oversize, mark both ends of tube to finished length. Use marking pencil (E271).
2. Mark tube (1) for the number of bends to be made as follows (APP E-50, Chart B):
 - a. Identify one end of the tube as the X-end. Mark distance from finished X-end to each bend with a line (1.1) around the tube.
 - b. Mark a reference line (1.2) about **2 inches** long, along the length of the tube at the X-end. Sight down the length of the tube from the X-end with the reference line facing up (**12 o'clock**).
 - c. At each bendline (1.1) rotate the tube clockwise the number of degrees shown in the DIAL C SET column. Make a reference line (1.3) about **2 inches** long, along the length of the tube at the bend line.

NOTE

Use the line at the X-end as the zero degree reference for tube rotation at each bend line.

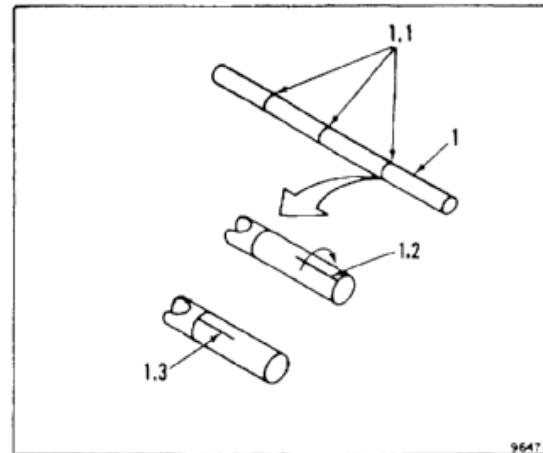

3. Make sure base (2) of tube bending set is securely mounted on work bench.
4. Install correct radius collar (3) for desired bend radius of tube (1) on holding pins (4).

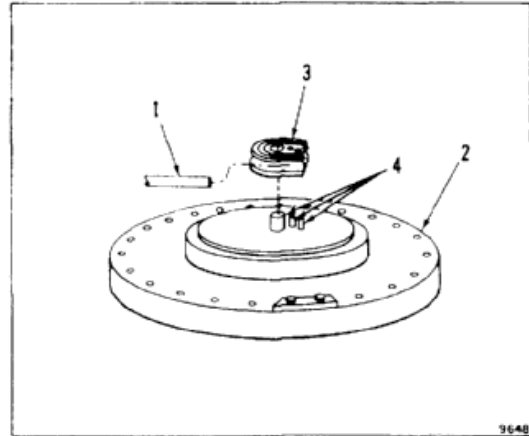

5. Position correct clamp block (5) for diameter of tube (1) on quick-lok clamp (6). Install two screws (7). Make sure radius groove (8) in clamp block aligns with radius groove (9) in collar (3).
6. Install quick-lok clamp (6) with two bolts (10), washers (11), and nuts (12).

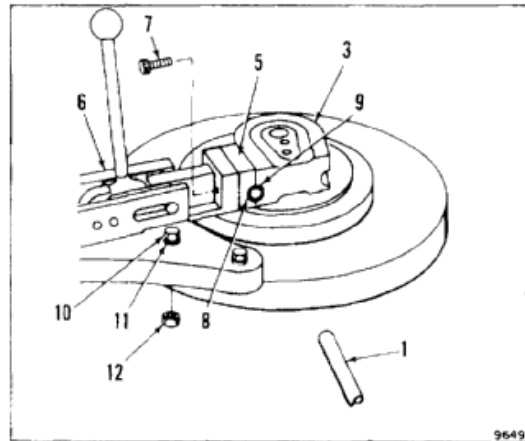

7. Adjust quick-lok clamp (6) with back-up screw (12.1) so moderate force is required to push lock handle (13) over center to lock it. Use spacer rods (13.1) as necessary.
8. Position tube (1) between collar (3) and clamp block (5) with bend line (1.1) against clamp block and degree line (1.3) at top of tube.
9. Position follow-block (14) against tube (1) and butted against clamp block (5).

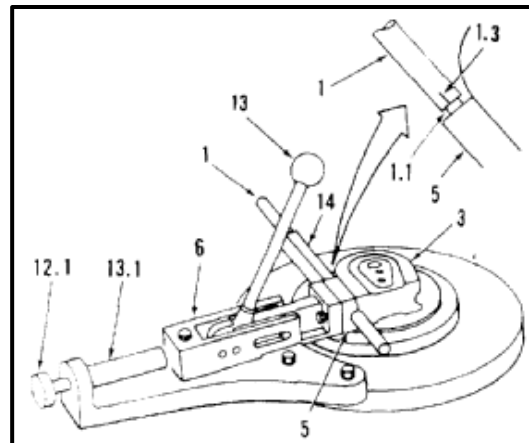

7-4.2 TUBE BENDING (AVIM) (Continued)

7-4.2

- 9.1. Check that control lever (14.1) is set to the right, as shown.
- 10. Adjust operating arm forming nose (15) against follow-block (14).

NOTE

The distance between two holes in the base is equal to **12.5°**.

- 11. Position angle stop (16) on base (2) at correct position to obtain desired bend (DIAL H DEG BEND Column of Chart B). Allow for springback. Install two bolts (17).

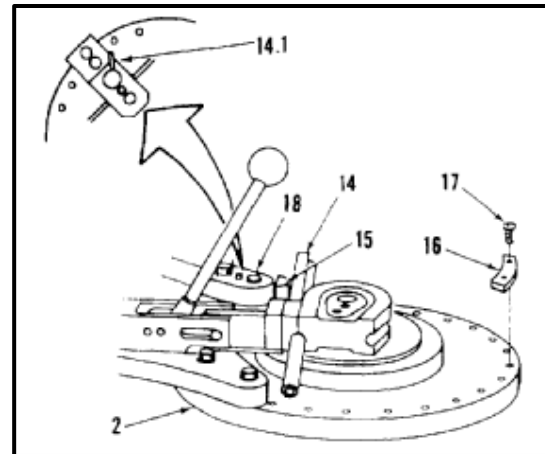

- 12. Advance operating arm (18) with steady pressure until angle stop (16) is met. Use extension arm (19) with operating arm (18) if additional leverage is required.
- 13. Return operating arm (18) to starting position and remove follow-block (14).
- 14. Release lock handle (13) on quick-lok clamp (6) and remove tube (1).
- 15. Repeat steps 8 thru 14 for all required bends in tube (1).

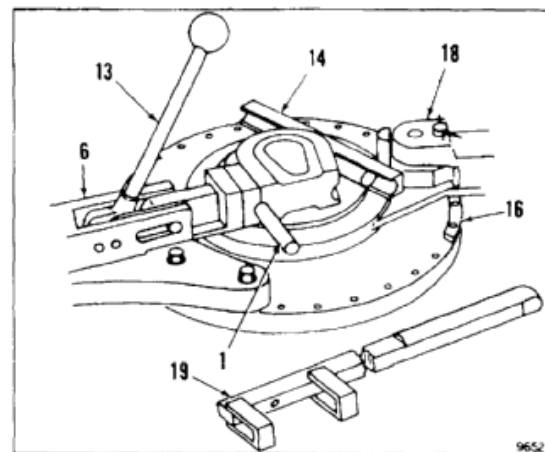

16. Check bends in tube (1) with micrometer as follows:

- a. Measure and record maximum outside diameter (OD).
- b. Measure and record minimum OD.

NOTE

Operations of steps c, d, and e can be expressed as follows:

$$\text{Percent Ovality} = \left(\frac{\text{max od} - \text{min od}}{\text{nominal od}} \right) \times 100$$

- c. Subtract OD of step 16b from OD of step 16a.
 - d. Divide result found in step 16c by average (nominal) OD of tube (1).
 - e. Multiply result found in step 16d by **100**.
 - f. Result found in step 16e is percent of ovality.
17. Acceptable level of tube ovality or flatness shall be **5 percent** maximum.

WARNING

Solvent (E161) is combustible and toxic. It can irritate skin and cause burns. Use only with adequate ventilation, away from open flame. In case of contact, immediately flush skin or eyes with water for at least **15 minutes**. Get medical attention for eyes.

18. Clean tube (1). Use solvent (E161).

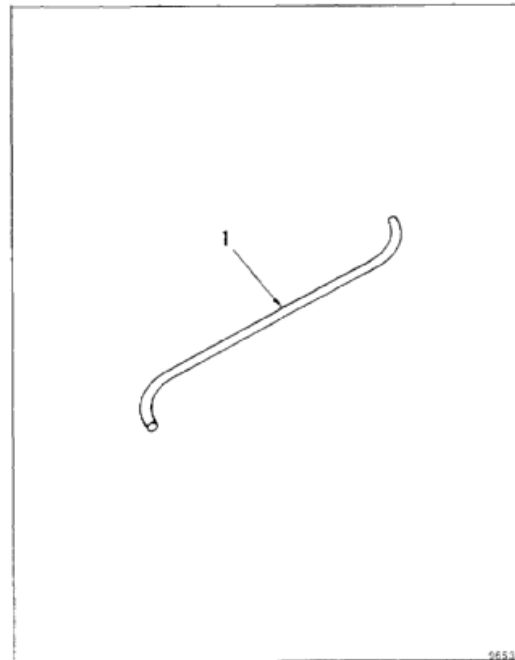

WARNING

Propelled debris can cause injury to eyes. Use source of compressed air under **30 psi** and eye protection to prevent injury to personnel.

19. Dry tube (1) with low pressure compressed air. Wear goggles to protect eyes.
20. Inspect tube (1). There shall be no wrinkles or kinks deeper than **1 percent** of nominal OD. There shall be no scratches deeper than **5 percent**.

FOLLOW-ON MAINTENANCE:

Install end fittings and sleeves as required (Task 7-5).
Apply appropriate identification markings (APP E-50).

END OF TASK

INITIAL SETUP**Applicable Configurations:**

All

Tools:

Hydraulic Repairer's Tool Kit, NSN 5180-00-323-4891
Permaswage Tube Repair Kit, D1202C-15-H10, NSN
5180-01-115-7008
Portable Hydraulic Power Supply

Materials:

Hydraulic Fluid (E199)
Gloves (E184.1)
Marking Pen (E271.2)

Parts:

Hydraulic Tube and Fittings, As Required

Personnel Required:

Aircraft Pneudraulics Repairer

References:

TM 55-1520-240-23P

Equipment Condition:

Applicable System Drained
Hydraulic Line to be Repaired Disconnected from
Structure
Applicable Work Platforms or Access Panels Open
(Task 2-2)

General Safety Instructions:**WARNING**

Hydraulic fluid (E199) is toxic. It can irritate skin and cause burns. Avoid inhaling. Use only with adequate ventilation. Avoid contact with skin, eyes, or clothing. In case of contact, immediately flush skin or eyes with water for at least **15 minutes**. Get medical attention for eyes.

NOTE

Repair procedures are typical for all separable and permanent fittings.

1. Determine type of repair to be performed from chart.

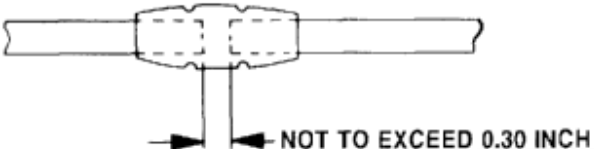
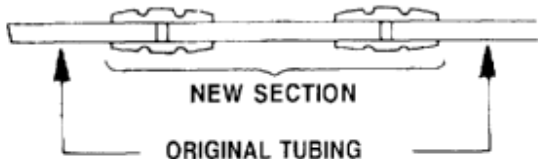
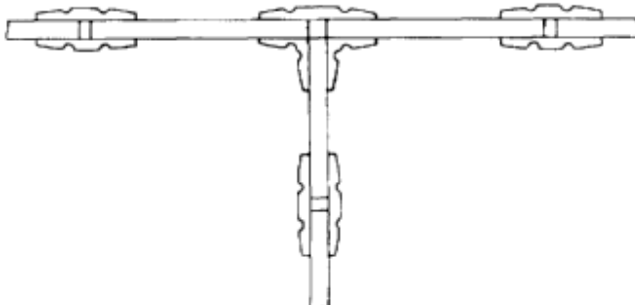
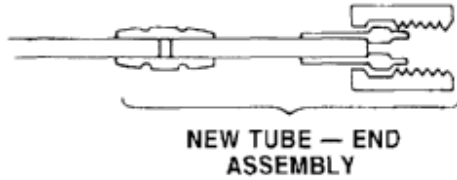
TYPE OF FAILURE	REPAIR METHOD
<p>1. PIN HOLE LEAK OR CIRCUMFERENTIAL CRACK IN TUBING.</p> 	<p>1.a. MAKE 1 OR 2 CUTS AS NECESSARY, TO ENABLE REMOVAL OF DAMAGED SECTION. IF 2 CUTS ARE REQUIRED, THE DISTANCE BETWEEN THEM SHALL NOT EXCEED <u>0.30 INCH</u>. IF THIS MEASUREMENT IS EXCEEDED, GO TO REPAIR METHOD 2.</p> <p>b. SWAGE ONE PERMANENT UNION IN TUBE SECTION UNDER REPAIR.</p>
<p>2. LONGITUDINAL CRACK IN TUBING (CRACK LENGTH IN EXCESS OF 0.30 INCH).</p> 	<p>2.a. MAKE 2 CUTS TO ENABLE REMOVAL OF DAMAGED SECTION.</p> <p>b. REMOVE DAMAGED SECTION AND DUPLICATE.</p> <p>c. SWAGE REPLACEMENT SECTION INTO TUBING UNDER REPAIR USING TWO PERMANENT UNIONS.</p>
<p>3. LEAKING TEE OR ELBOW (PERMANENT TUBE CONNECTION TYPE).</p> 	<p>3.a. CUT OUT DEFECTIVE TEE OR ELBOW.</p> <p>b. DUPLICATE TUBING SECTIONS FOR EACH BRANCH.</p> <p>c. SWAGE SPLICE SECTIONS TO TEE OR ELBOW.</p> <p>d. CONNECT EACH SPLICE SECTION TO TUBING UNDER REPAIR USING A TUBE TO TUBE UNION.</p>
<p>4. LEAKING SEPARABLE END FITTING.</p> 	<p>4.a. CUT TUBING TO REMOVE DEFECTIVE FITTING.</p> <p>b. MAKE UP SPLICE SECTION.</p> <p>c. SWAGE APPROPRIATE END FITTING TO END OF SPLICE SECTION.</p> <p>d. CONNECT NEW END FITTING TO MATING EQUIPMENT CONNECTION, TORQUING NUT AS REQUIRED.</p> <p>e. SWAGE 1 PERMANENT UNION CONNECTING NEW TUBE-END ASSEMBLY TO TUBE SECTION BEING REPAIRED.</p>

42 x 51

D145-10962-SPA

ADDITIONAL INFORMATION APPLICABLE WHEN MAKING ANY OF THE FOUR TYPES OF REPAIRS. (1 THRU 4)

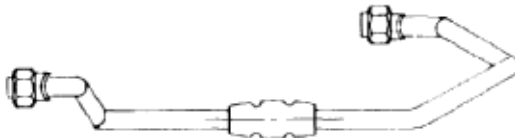

1. PRIOR TO CUTTING THE TUBE, DRAW A LINE PARALLEL TO THE TUBE RUN ACROSS THE SECTION TO BE CUT. USING THE MARKING PEN AND A RULER.
2. CUT THE TUBING.
3. IF A TUBE END IS TO BE REPLACED, MAKE SURE THE LINE IS PLACED IN THE SAME LOCATION ON THE NEW TUBE AS THE TUBE SECTION THAT HAS BEEN REMOVED.

CAUTION

DO NOT FORGET TO PLACE TUBE INSERTION MARK ON ALL TUBE ENDS. DAMAGE TO TUBING CAN OCCUR.

4. DRAW A LINE ACROSS THE FITTING,
5. INSTALL THE TUBE RUN AND LOCATE THE FITTING. FINGER TIGHTEN ANY END FITTINGS. (ONE END OF THE FITTING MAY BE SWAGED ON THE BENCH, IF POSSIBLE.)
6. PLACE THE SWAGE TOOL ON THE FIRST END BEING SWAGED, LINING UP THE LINE ON THE TUBE END BEING SWAGED WITH THE LINE ON THE FITTING.
7. REPEAT THIS STEP WITH THE OTHER ENDS TO BE SWAGED.
8. TIGHTEN ANY END FITTINGS TO THEIR PROPER TORQUE VALUE.

2. Select applicable repair kit according to table:

MAJOR EQUIPMENT COMPONENTS:	FOR USE WITH TUBE SIZES:
Tube Repair Kit D12102C-01-01	3/16, 1/4, 5/16, and 3/8 inch
Tube Repair Kit D12102C-06-06	1/2, 5/8, and 3/4 inch
Tube Repair Kit D12102C-09-04	1, 1-1/4, and 1-1/2 inch

3. Determine correct tube and fitting clearances:

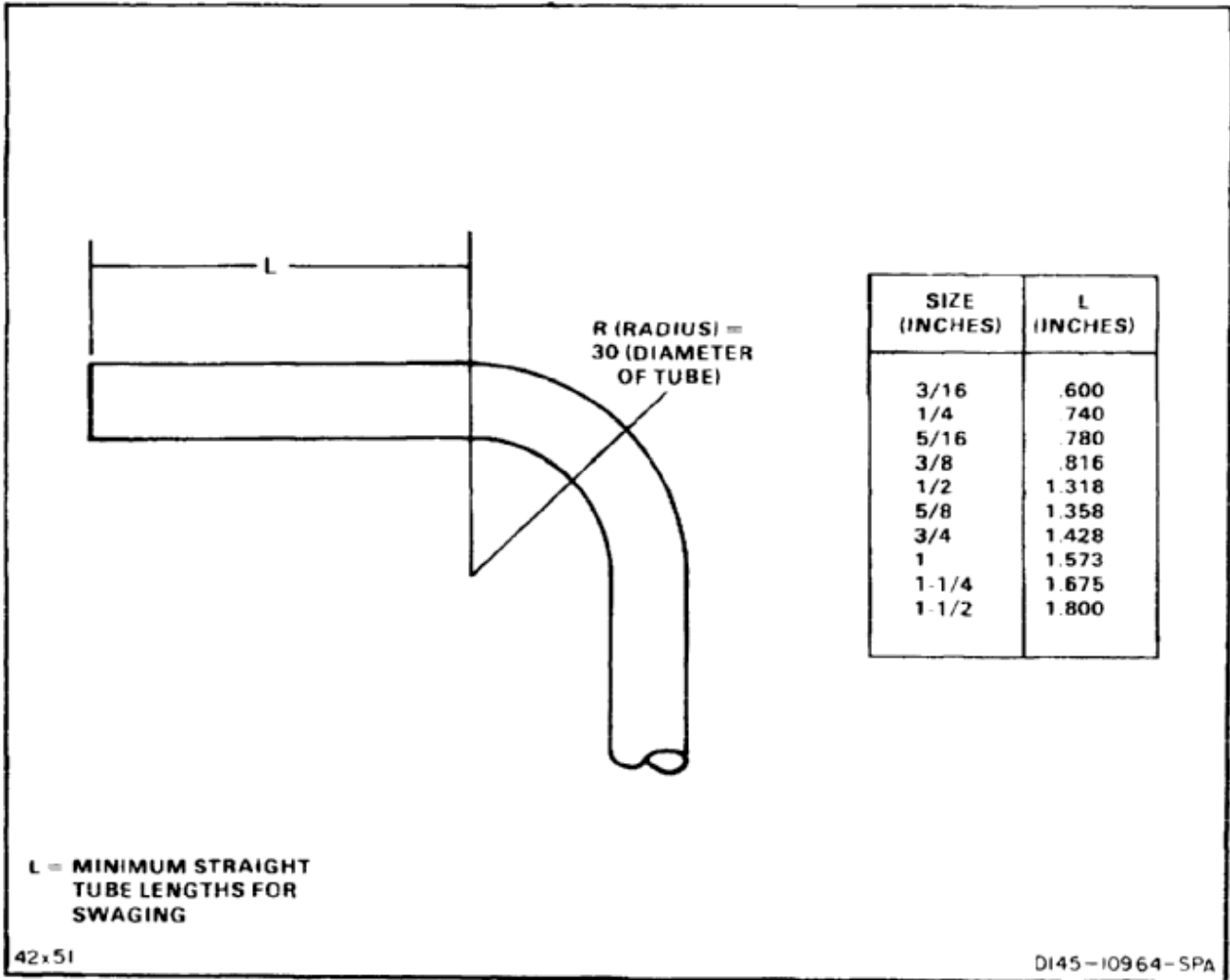

CUT TUBE

4. Select appropriate chipless cutter (1) for size of tube (2). Check that ratchet handle (3) is operating freely and cutter wheel (4) is clear of cutter head opening. Make sure cutter is clean and properly lubricated. See step 3 for correct tube and fitting clearance.
5. Rotate the cutter head (5) to accept tube (2). Locate cutter (1) in cutting position on tube. Tube shall be centered on two rollers (6) and cutter wheel (4).
6. Tighten drive screw (7) until light contact is made on tube (2) by cutter wheel (4). Tighten screw an additional **1/8 to 1/4 turn**. Do not overtorque.
7. Rotate ratchet handle (3) thru arc of clearance until there is noticeable ease of rotation.
8. Tighten screw (7) an additional **1/8 to 1/4 turn**. Repeat step 7 until cut is complete.
9. Check remaining section of tube (2). Cut shall be square to tube centerline within **1/2°**.

CAUTION

Overtorquing soft tubing will cause a large burr. Overtorquing hard tubing can damage the cutter wheel.

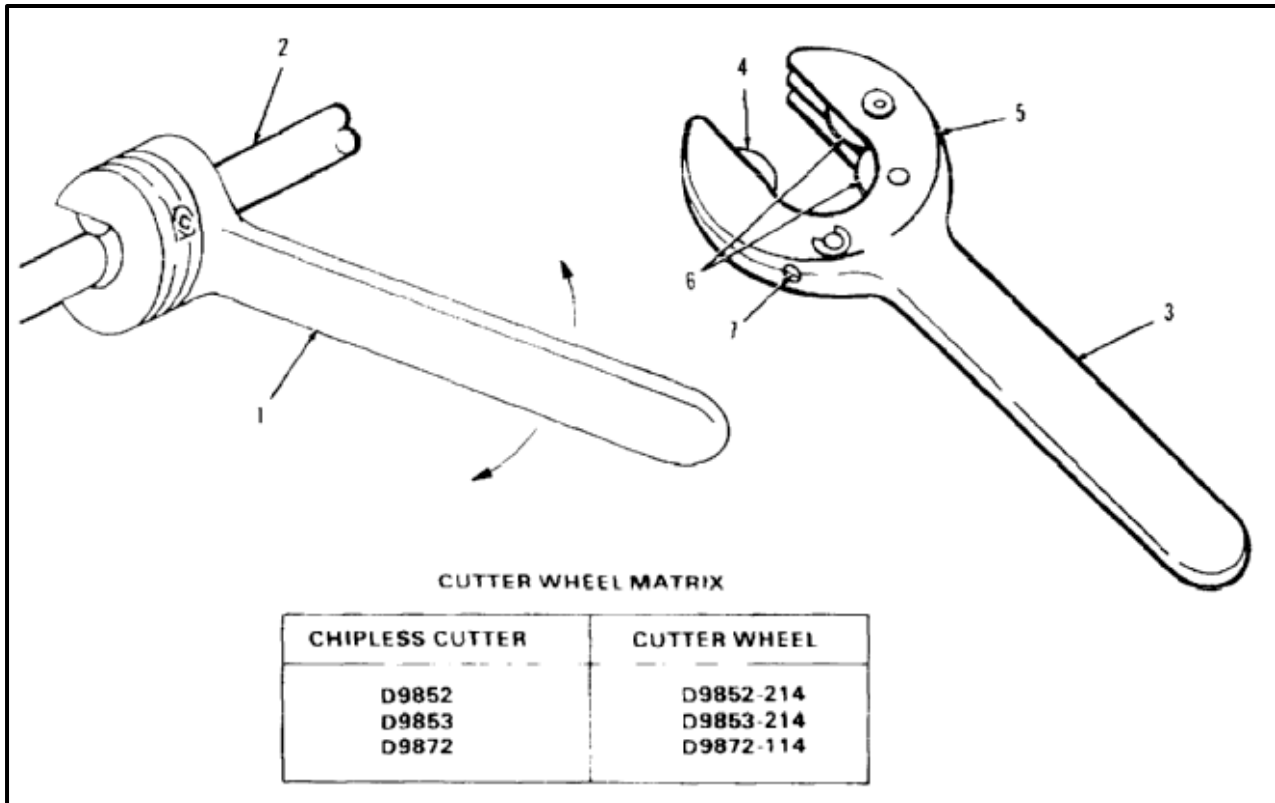

DEBURR TUBE



Do not place fitting over tube end until tube end is properly deburred. Damage to the fitting may result.

10. Inspect and assemble correct deburring tool and stem subassembly.

DEBURRING TOOL	TUBE OD INCH	TUBE WALL THICKNESS INCH	STEM SUBASSEMBLY REQUIRED
D9851	1/4	0.016 - 0.028	D9851-13-04
		0.028 - 0.050	D9851-13-03
	3/8	0.016 - 0.035	D9851-13-05
		0.016 - 0.035	D9851-13-06
		0.035 - 0.058	D9851-13-07
D9850	1/2	0.016 - 0.042	D9850-13-08
		0.042 - 0.065	D9850-13-09
	5/8	0.016 - 0.058	D9850-13-10
		3/4	0.016 - 0.065
D9849	1	0.020 - 0.083	D9849-13-06
		0.024 - 0.065	D9849-13-20
	1-1/4	0.065 - 0.109	D9849-13-21
		1-1/2	0.028 - 0.083

7-5 REPAIR PERMASWAGE PLUMBING (Continued)

7-5

11. Lightly lubricate plug (1) with hydraulic fluid (E199).
12. Press in plunger (2). Carefully insert tool into the tube (3) until cutter (4) is approximately **1/8 inch** away from burr. Release plunger to allow plug to expand and seal tube.
13. Rotate knurled body (5) of deburring tool clockwise while applying slight pressure to cutter (1). Continue to rotate until cutter rotates smoothly, indicating tube end is deburred. Do not cut too deep into wall of tube. Width of deburring chamfer shall not exceed **1/2 wall** thickness of tube.
14. Without depressing plunger, pull tool from tube (3) until first bulge of plug (1) is exposed. Wipe off tube and plug. Inspect tube end for proper deburring. Repeat step 13, if needed.
15. Remove deburring tool from tube (3). Clean all chips from tube and tool.

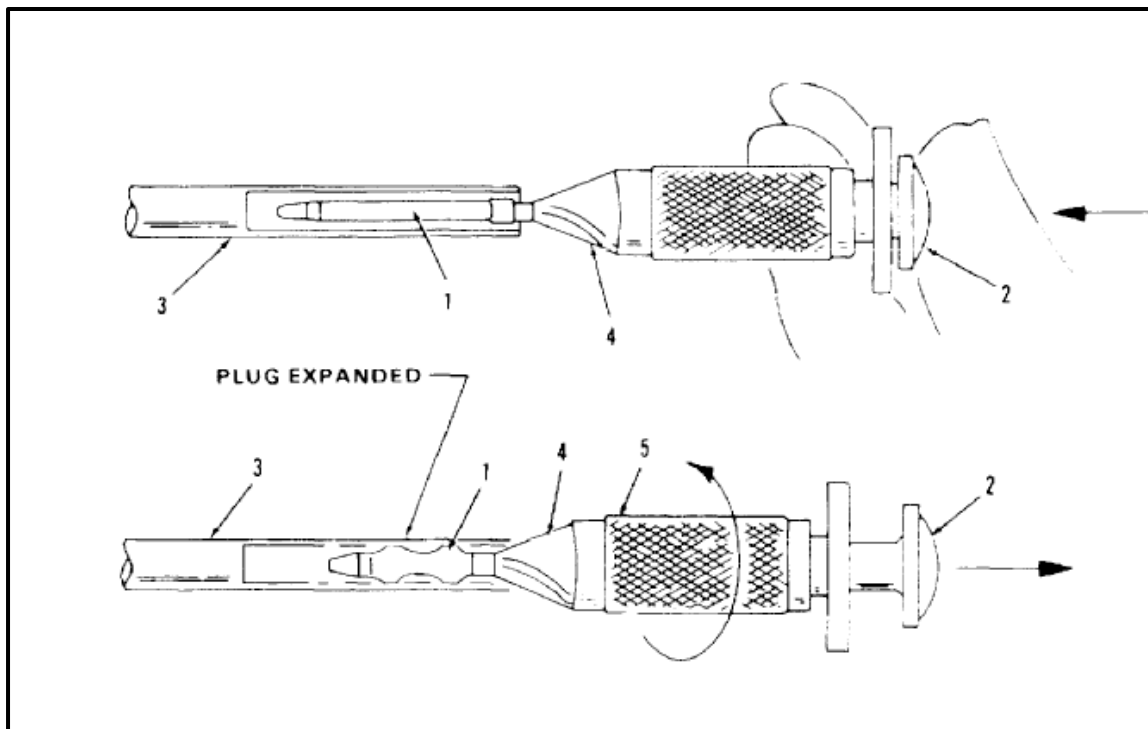

PREPARE REPLACEMENT TUBE

16. Select a piece of tube of correct length. Tube shall be the same as that being replaced.
17. Bend replacement tube to shape of original tubing leaving some excess for trim at both ends. Remove all burrs. (Refer to steps 10 thru 15.)



Do not place fitting over tube end until tube end is properly deburred. Damage to fitting may result.

18. Trim the fitting end of the tube. (Refer to steps 4 thru 9.) Place fitting over tube to compare length to original fitting and tube.
19. Install fitting onto the applicable component. Position tube within fitting, aligning the other end of tube with mating tube. Remove tube and trim the other end as required. (Refer to steps 4 thru 9.) The maximum gap allowed between mating tubes is **0.30 inch**. See figure for allowing mismatch.
20. Remove all burrs from tube. (Refer to steps 10 thru 15.)

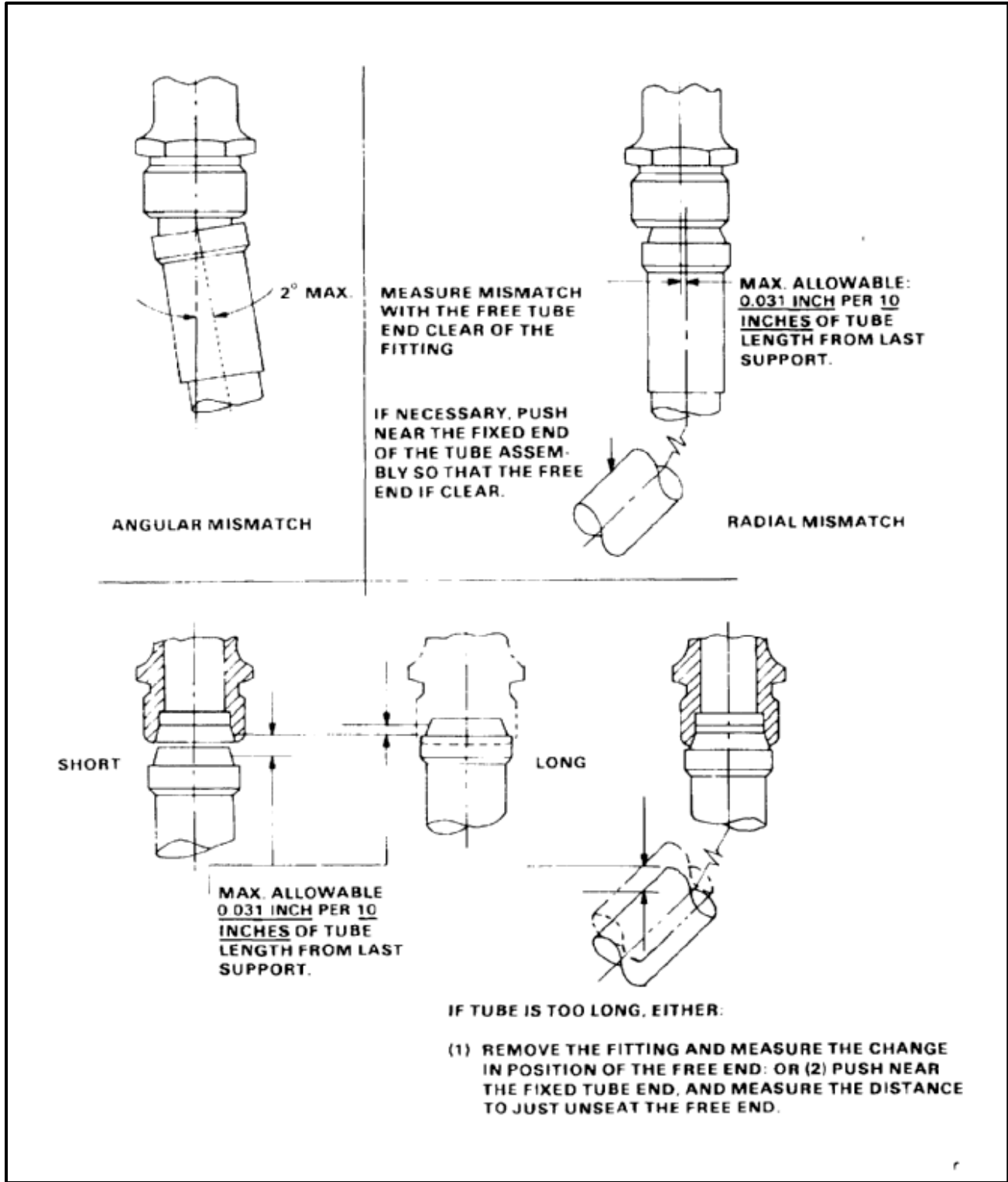

SWAGE TUBE

21. Mark tube ends. Use correct marking tool for size of tube to be swaged. When marking with tool D9862, place lip stop against end of tube as shown. Using the slot as a guide, mark the tube in two places **180°** apart with marking pen (E271.2). If marking tool D9862 and marking pen (E271.2) are not available, see table for tube insertion band.
22. Position prepared tube within fitting. Align mating ends and position union fitting. Check to see if swaging at separable union fitting can be done with it installed on the component. If not, mark fitting and tube so that proper clocking is obtained. Swage fitting off aircraft as follows:

TUBE INSERTION MARKING

TUBE SIZE	A	
	MINIMUM	MAXIMUM
1/4 (-4)	.615	.625
5/16 (-5)	.655	.665
3/8 (-6)	.690	.700
1/2 (-8)	1.193	1.203
5/8 (-10)	1.233	1.243
3/4 (-12)	1.303	1.313
1 (-16)	1.448	1.458

NOTE
ALL DIMENSIONS
IN INCHES

.300 STRIPE WHEN USING
MARKING TOOL

A .300 MAX

7-5 REPAIR PERMASWAGE PLUMBING (Continued)

7-5

23. Connect the hydraulic pressure line from portable hydraulic power supply to fitting on base of swaging tool.
24. Set selector valve on power supply to EXHAUST to relieve all line pressure.



If you do not tighten the knurled nut against the yoke, the yoke assembly will fail. You may need to rotate the yoke **180°** to obtain a snug fit.

- 24.1. Slide square portion of power unit into yoke assembly. Tighten knurled nut snugly against yoke.
25. Install set of die blocks in swaging tool. Position tool below level of power supply. These steps will prevent air from getting in the hose and power supply. Cycle power supply to **2000 psi** followed by EXHAUST, two or three cycles to bleed air from cylinder.

NOTE

Some separable fittings are swaged without locators.

26. See chart of swage tool envelopes to select correct upper and lower die block assemblies for size of fitting to be swaged. Insert lower die block with correct fitting locator into tool. When properly inserted, filling locator is on opposite end of tool relative to latch.
27. Place swaging tool and dies over separable fitting. Make sure fitting is positioned properly. Refer to figure showing acceptable limits of tube insertion into union. Push up latch to lock dies in place.
28. Position face of swaging tool against location mark on tube. Outer edge of latch must fall within location mark. Tube insertion must be as shown in illustration of tube insertion limits.
29. Set selector valve to appropriate hydraulic output.
30. Actuate swaging tool with **5,000 to 5,500 psi** hydraulic pressure. If shop air input is not available, use hand pump.
31. Set selector valve to EXHAUST to relieve pressure completely.
32. Slide open latch and remove swaging tool from swaged joint.

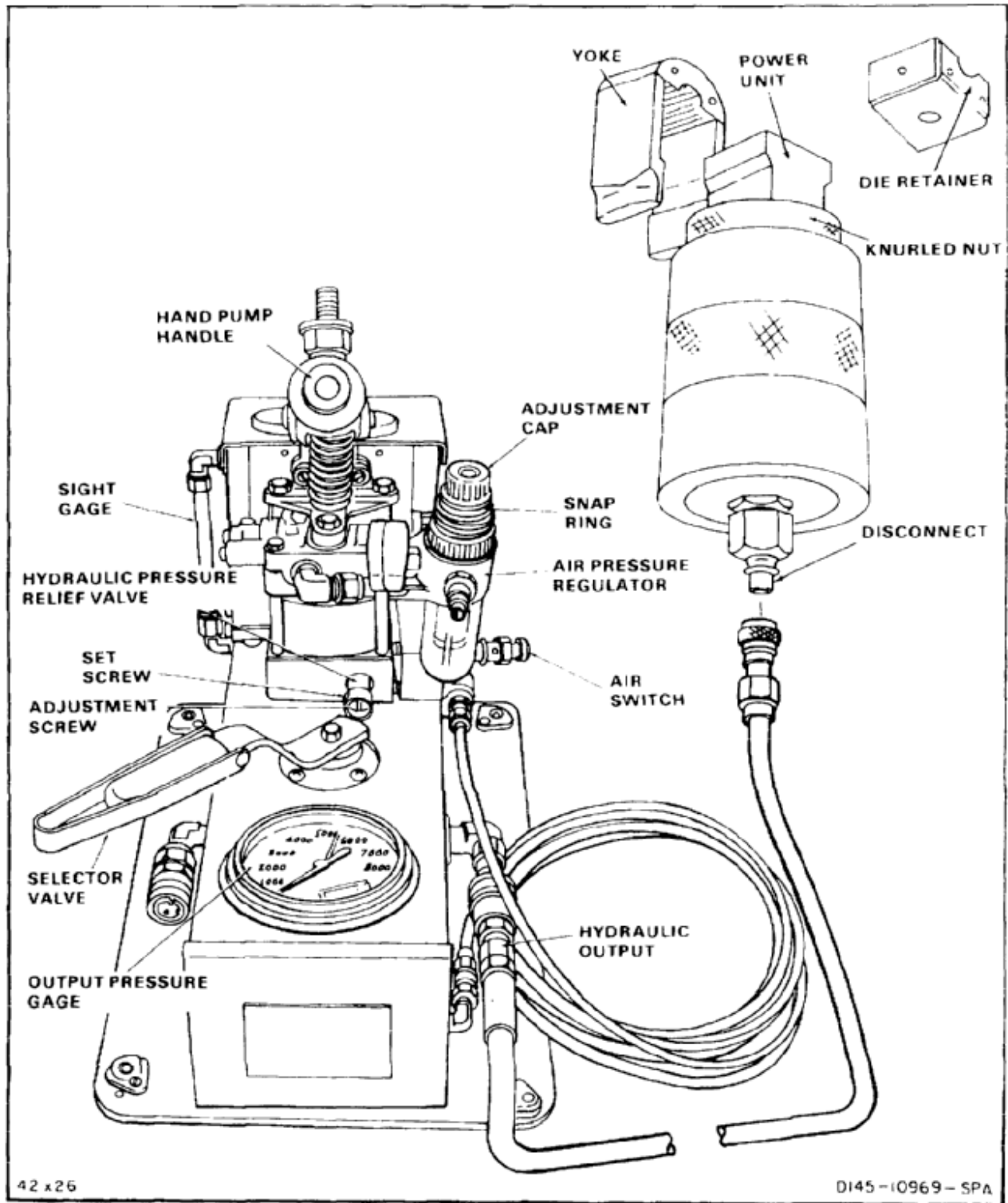

NOTE

Swaging dies make ridges on swaged fitting. Check after-swage dimensions between ridges.

33. Inspect swaged end with appropriate size go-no-go inspection gage according to illustration of after-swage dimensions. If gage does not fit, fitting may be reswaged only once. Repeat steps 27 thru 33.
34. If swaging operation was done off aircraft, position and attach separable fitting to component. Align mating ends and position union fitting. Torque fitting to its final torque, making sure fixed portion of fitting is held stationary.
35. With union fitting positioned correctly, repeat steps 24 thru 31 for both ends of fitting.

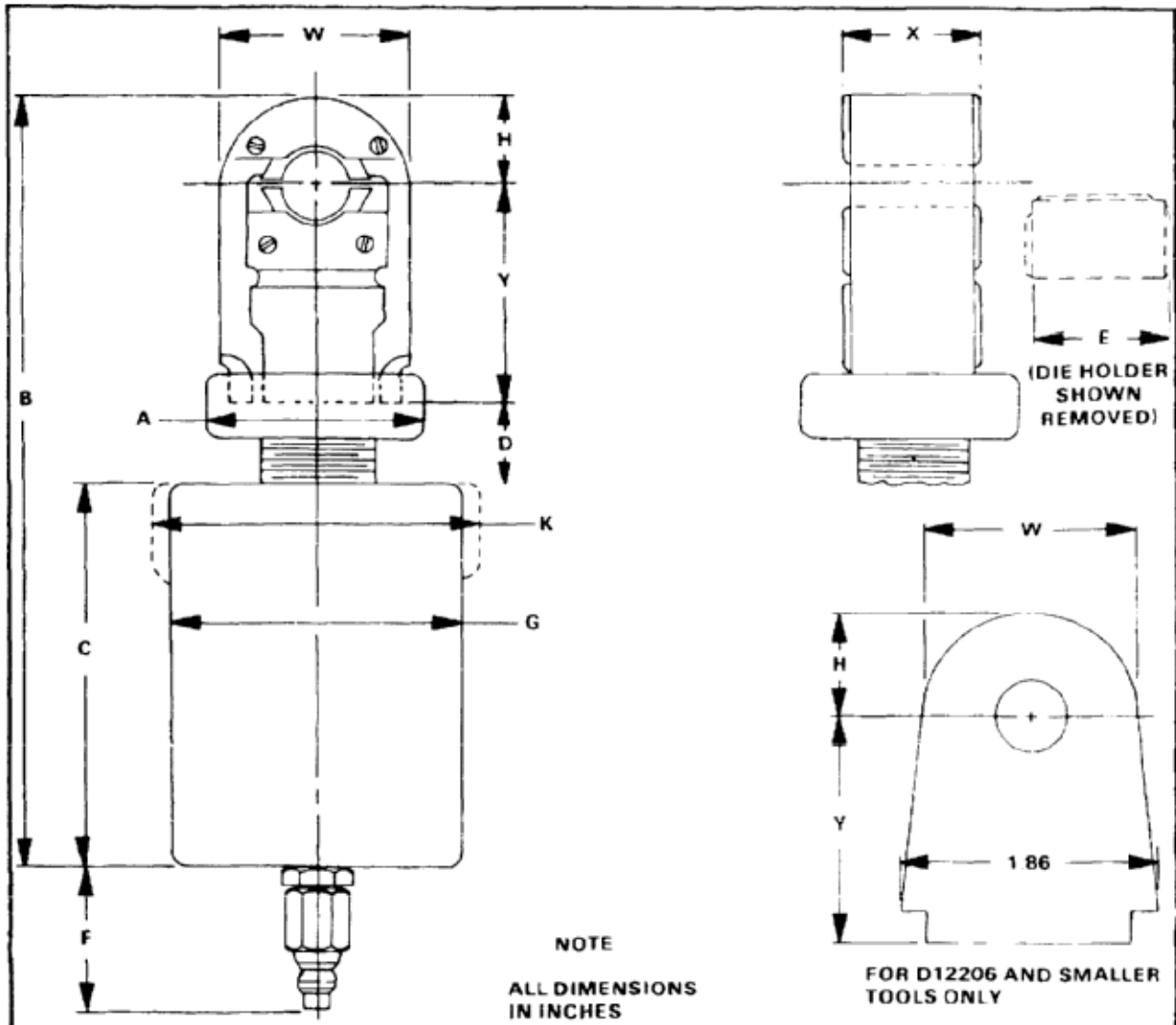

SWAGE TOOL ENVELOPES

P.N.	SIZE	W	H	Y	X	A	B	C	D	E	F	G	H
D12204	1/4	1.60	.62	1.86	.95	1.90	5.60	2.15	.97	.89	1.47	3.15	-----
D12205	5/16	1.60	.62	1.86	.95	1.90	5.60	2.15	.97	.89	1.47	3.15	-----
D12206	3/8	1.60	.62	1.86	.95	1.90	5.60	2.15	.97	.89	1.47	3.15	-----
D12208	1/2	2.12	.90	2.54	1.52	2.50	8.72	4.43	.85	1.46	1.47	3.24	-----
D12210	5/8	2.12	.90	2.54	1.52	2.50	8.72	4.43	.85	1.46	1.47	3.24	-----
D12212	3/4	2.41	.96	2.63	1.52	2.69	8.95	4.43	.83	1.46	1.47	3.62	-----
D12216	1	3.30	1.39	3.41	1.78	3.50	11.04	5.08	1.17	1.71	1.47	4.04	4.10

20x5I

D145-10970-SPA

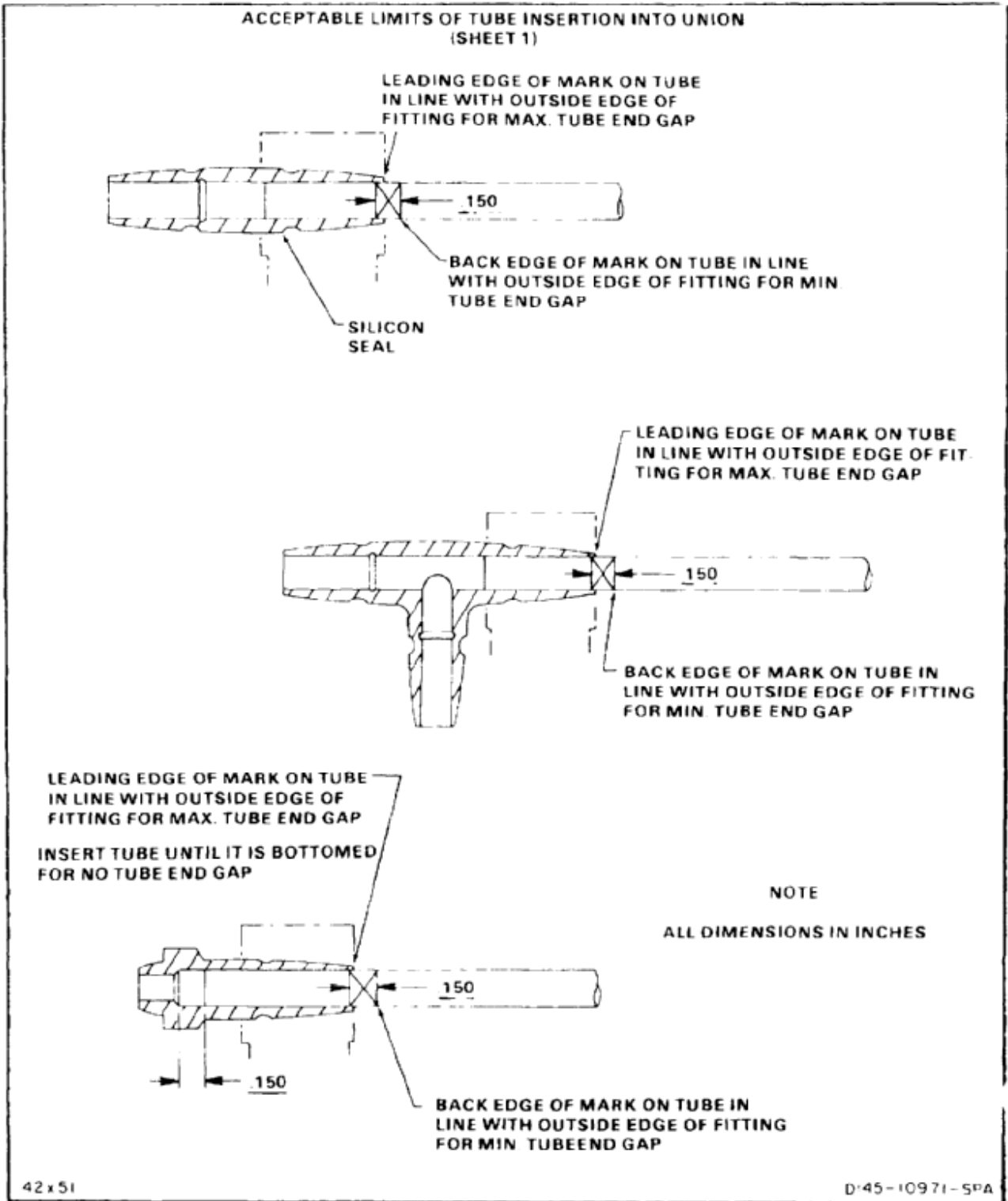

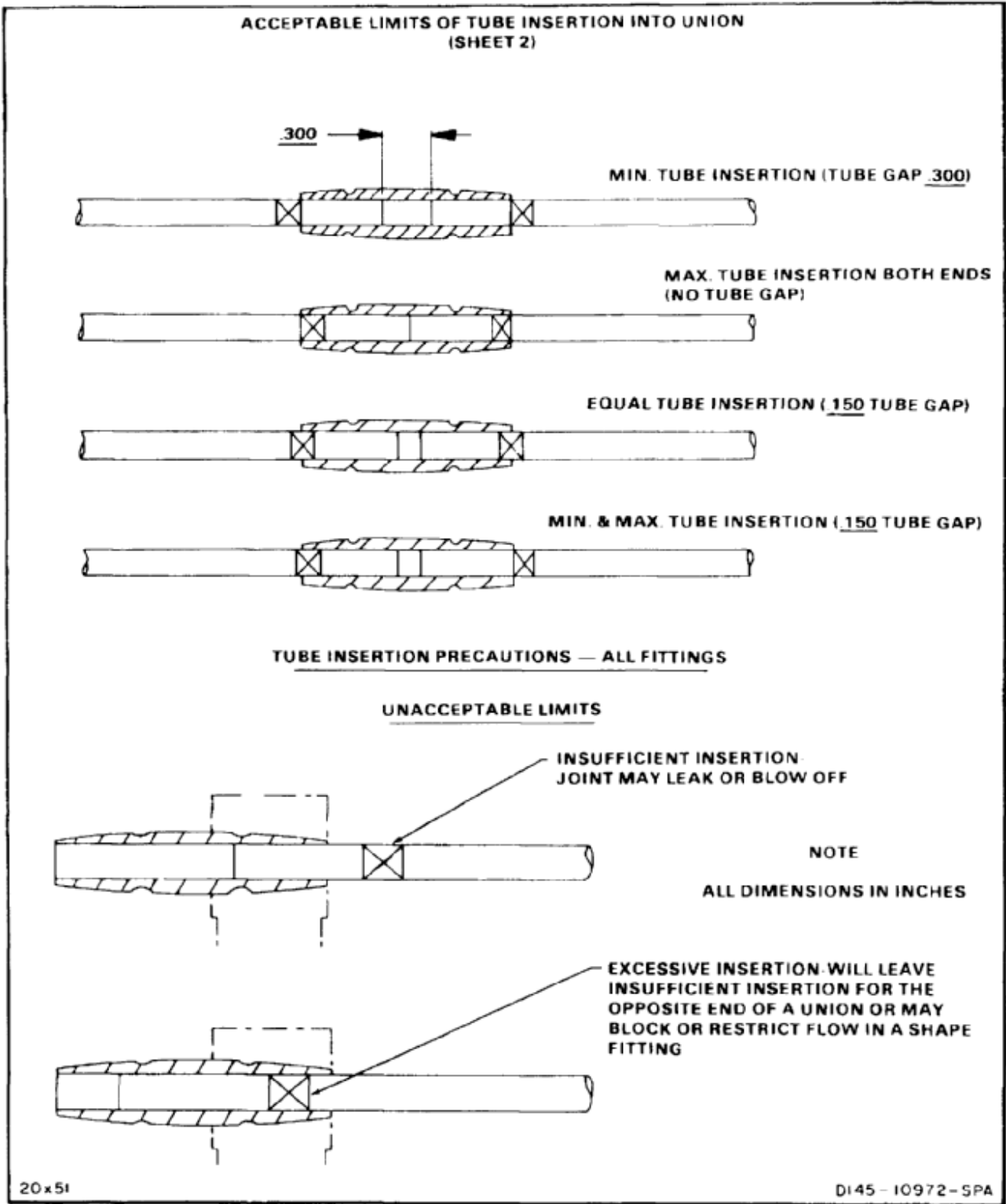

INSPECTION GAGE D12-9892

A

GAGE SHOULDER MUST CONTACT FITTING END

B

A PORTION OF THE INSERTION MARK MUST BE VISIBLE AND SOME PORTION OF THE INSERTION MARK MUST BE UNDER THE FITTING END

IT IS PERMISSIBLE AND ADVISED TO RESWAGE FITTINGS TO MEET THE PROPER SWAGE DIMENSIONS. NO EXTENSIVE REDUCTION IN FITTING DIAMETER BEYOND THE SPECIFIED TOLERANCE LIMITS CAN OCCUR IF THE PROPER UPPER AND LOWER DIE BLOCK ASSEMBLIES ARE EMPLOYED

TUBE DIA. (IN.)	MIN. SWAGED LGTH B DIM. (IN.)	MAX. SWAGED DIA A DIM. (IN.)
1/4 (-4)	0.460	0.315
5/16 (-5)	0.500	0.381
3/8 (-6)	0.530	0.447
1/2 (-8)	1.020	0.606
5/8 (-10)	1.020	0.735
3/4 (-12)	1.020	0.863
1 (-16)	1.160	1.144

42 x 51

D145 - 10973 - SPA

FOLLOW-ON MAINTENANCE:

- Connect repaired tube to structure.
- Fill and bleed applicable hydraulic reservoir (Tasks 7-16 or 7-335).
- Apply hydraulic power to helicopter (Task 1-36 or 1-38).
- Check repaired tubing for leaks.
- Perform operational check of hydraulic system (TM 55-1520-240-T).
- Close applicable work platforms or access panels (Task 2-2).

END OF TASK

INITIAL SETUP

Applicable Configurations:

All

Tools:

Hydraulic Repairer's Tool Kit, NSN 5180-00-323-4891
 Aircraft Inspector's Tool Kit, NSN 5180-00-323-5114
 Felt Tip Pen, Alcohol Soluble D10058
 Adapter and Reducer Tool Kit (See Table)
 Torque Wrench, 0 to 600 Inch-Pounds

Materials:

Dry Cleaning Solvent (E162)
 Hydraulic Fluid (E199)
 Cloth (E120)
 Gloves (E186)
 Zinc Chromate Primer (E291)
 Acid Brush

Personnel Required:

Aircraft Pneudraulics Repairer
 Aircraft Structural Repairer
 Inspector

References:

TM 43-0104
 TM 55-1520-240-23P

Equipment Condition:

Off Helicopter Task (Instructions)

General Safety Instructions:**WARNING**

Dry cleaning solvent (E162) is flammable and toxic. It can irritate skin and cause burns, use only in well-ventilated area, away from heat and open flame. In case of contact, immediately flush skin or eyes with water for at least **15 minutes**. Get medical attention for eyes.

NOTE

Procedures are the same for flared and flareless adapters and reducers, except where noted.

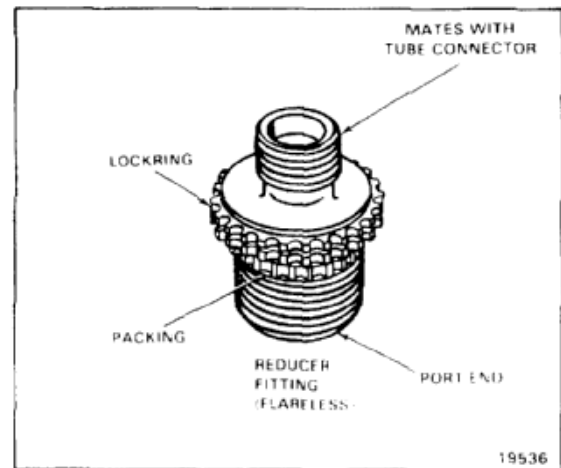

REMOVAL

1. Clean surrounding area. Use dry cleaning solvent (E162).
2. If sealant has been used to cover locking (1), carefully remove sealant.
3. If reinstalling same fitting index mark locking (1) position. Use marking pen.

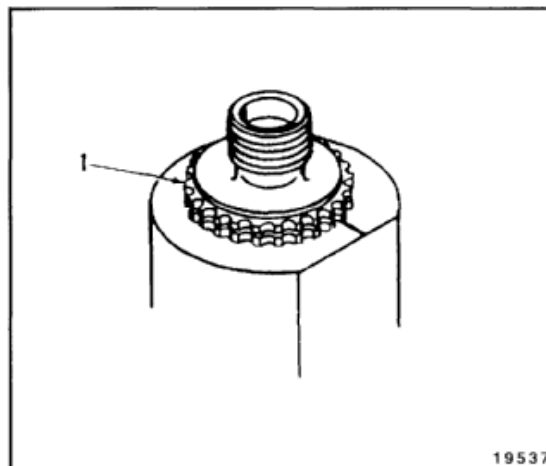

4. Select proper locking removal tool from table 1.
5. Spread puller halves (2) by retracting sleeve (3) until pin (4) bottoms in groove (5).
6. Place tool over Rosan fitting (6). Close puller halves (2) over groove (5) of locking ring (1). Slide sleeve (3) over puller halves. Check for proper engagement with locking ring groove.

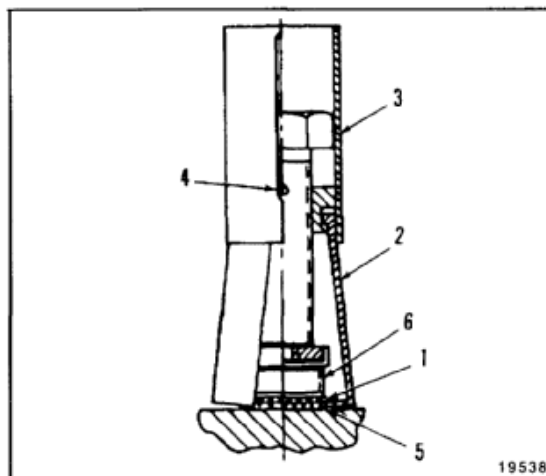

CAUTION

Be sure to pull locking (1) straight and only enough to clear locking serrations.

7. Turn bolt (7) clockwise while holding sleeve (3). This will pull locking out of port (8). When the external serrations of locking (1) clear the port, stop turning bolt.
8. Loosen bolt (7), lift sleeve (3), and free puller halves (2). Remove tool from Rosan fitting (6).

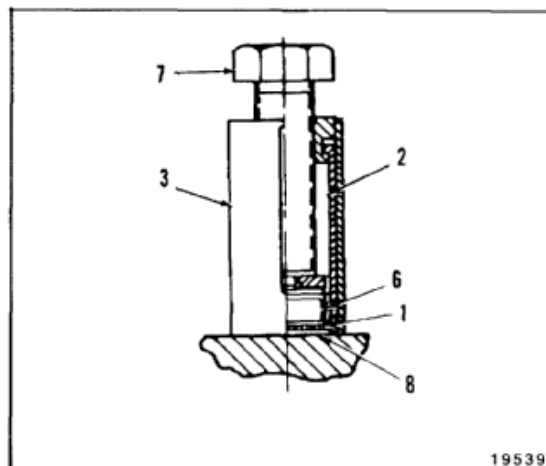

TABLE 1

TOOL KIT PART NUMBER	TUBING OD INCHES	ROSAN REDUCER PART NUMBER REF	ROSAN ADAPTER PART NUMBER REF	INSTALLATION TOOLS				
				PACKING INSTALLATION TOOL NUMBER	COMBINATION WRENCH AND DRIVE TOOL NUMBER	WRENCH PART NUMBER	LOCKRING DRIVE TOOL NUMBER	LOCKRING REMOVAL TOOL NUMBER
KM-35	1/8	— —	RFK9802-13 RFK9902-13	0RT216	RF9802DW	RF6902W	RF9802DEK	RF02LPDE
KM-36	3/16	— —	RFK9803-13 RFK9903-13	0RT250	RF9803DW	RF6903W	RF9803DEK	RF03LPDE
KM-18	1/4	RF9804-13 RF9904-13	RFK9804-13 RFK9404-13	0RT312	RF9804DW	RF6904W	RF9804DEK	RF04LPDE
KM-29	5/16	8F9805-13 RF9905-13	RFK9805-13 RFK9905-13	0RT375	RF9805DW	RF6805W	RF9805DEK	RF05LPDE
KM-30	3/8	RF9806-13 RF9906-13	RFK9806-13 RFK9906-13	0RT437	RF9806DW	RF6906W	RF9806DEK	RF06LPDE
KM-13	1/2	RF9808-13 RF9908-13	RFK9808-13 RFK9908-13	0RT562	RF9808DW	RF6908W	RF9808DEK	RF08LPDE
KM-19	5/8	RF9810-13 RF9910-13	RFK9810-13 RFK9810-13	0RT687	RF9810DW	RF6910W	RF9810DEK	RF10LPDE
KM-31	3/4	RF9812-13 RF9912-13	RFK9812-13 RFK9812-13	0RT812	RF9812DW	8F6912W	RF9812DEK	RF12LPDE
KM-32	7/8	RF9814-13 —	— RFK9914-13	0RT937	RF9814DW	RF6914W	RF9814DEK	RF14LPDE
KM-14	1	RF9816-13 RF9916-13	RFK9816-13 RFK9916-13	0RT1125	RF9816DW	RF6916W	RF9816DEK	RF16LPDE
KM-15	1-1/4	RF9820-13 RF9920-13	RFK9820-13 RFK9920-13	0RT1312	RF9820DW	RF6920W	RF9820DEK	RF20LPDE
KM-28	1-1/2	RF9824-13 RF9924-13	RFK9824-13 RFK9924-13	0RT1625	RF9824DW	RF6924W	RF9824DEK	RF24LPDE
KM-33	2	— —	RFK9832-13 RFK9932-13	0RT2125	RF9832DW	RF6932W	RF9832DEK	RF32LPDE

NOTE

Combination wrench and lockring drive tool RF98--DW series may be used in place of wrench and lockring drive tools RF69--W and RF98--DEK for adapters, but not for reducers.

9. Remove Rosan fitting (6) from port (8) as follows:
 - a. Select proper wrench (10) from table 1.
 - b. Engage wrench serrations with those of adapter (9).
 - c. Turn wrench (10) counterclockwise to unscrew fitting (6) from port (8).
10. Remove fitting (6) from port (8).

NOTE

Rosan fittings cannot be repaired and must be replaced if threads are damaged or other defects are found.

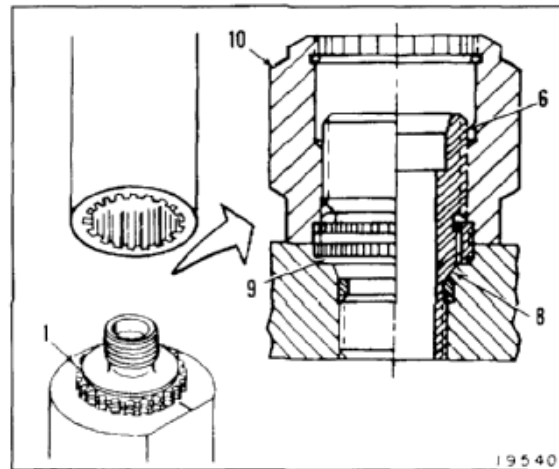

11. Inspect serrations (11) around port (8) for condition. If damaged, replace component.
12. Plug port (8) to prevent fluid contamination.
13. Inspect Rosan fitting (6) for cleanliness.
14. Ensure locking (1) is not cocked on fitting (6).
15. Ensure threads and fitting serrations (9) are not damaged.
16. Remove old packing (12) from fitting (6).
17. Inspect packing (12) contact area. No damage is allowed.
18. Inspect metal-to-metal sealing surfaces located immediately above packing contact area for scratches or rough spots. None are allowed.

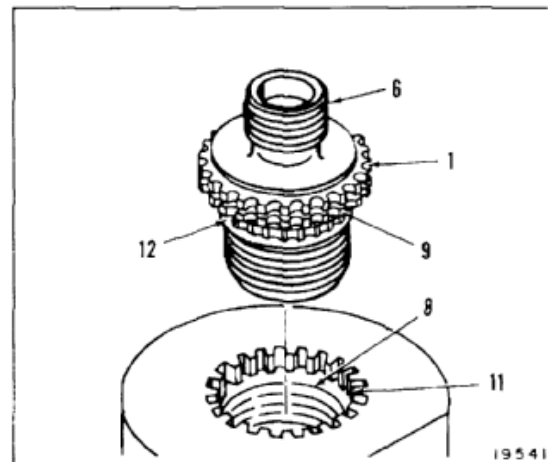

INSTALLATION

19. Select packing installation tool (13) from table 1, and packing (12) from table 2.
20. Place packing (12) on tool (13). Place installation tool over the port thread of fitting (6).
21. Submerge tool (13) and packing (12) in hydraulic fluid (E199).
22. Slide packing (12) over tool (13) and onto fitting (6). Ensure that packing (12) is not twisted and is properly seated in groove (5).
23. Remove packing installation tool.

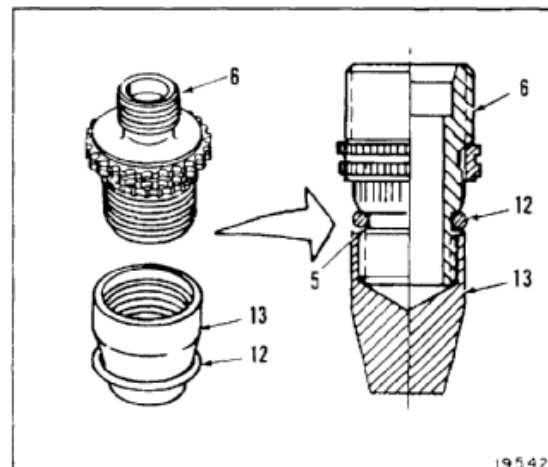

CAUTION

Avoid packing damage. Do not rotate Rosan fitting clockwise during installation.

- 24. Insert packing end of fitting (6) into port (8). Hand-tighten fitting until seated.

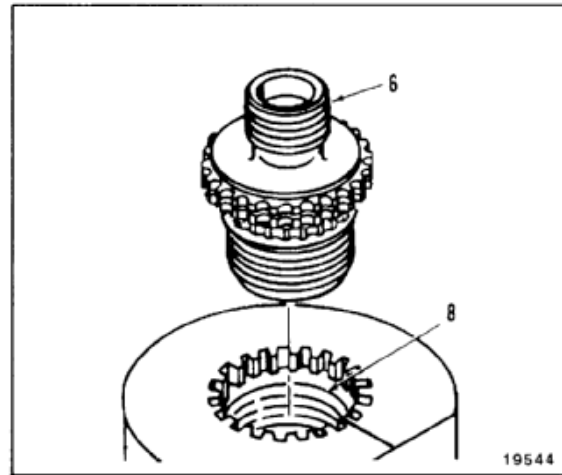

TABLE 2

ROSAN REDUCER PART NUMBER REF	ROSAN ADAPTER PART NUMBER REF	PACKING PART NUMBER	INSTALLATION TORQUE INCH-POUNDS
	RFK9802-13 RFK9902-13	MS28775-07	16-21
	RFK9803-13 RFK9903-13	MS28775-08	38-45
RF9804-13 RF9904-13	RFK9804-13 RFK9904-13	MS28775-10	60-100
RF9805-13 RF9905-13	RFK9805-13 RFK9905-13	MS28775-11	100-120
RF9806-13 RF9906-13	RFK9806-13 RFK9906-13	MS28775-12	180-245
RF9808-13 RF9908-13	RFK9808-13 RFK9908-13	MS28775-14	430-510
RF9810-13 RF9910-13	RFK9810-13 RFK9910-13	MS28775-16	600-680
RF9812-13 RF9912-13	RFK9812-13 RFK9912-13	MS28775-116	855-945
RF9814-13	RFK9914-13	MS28775-18 MS28775-118	995-1105
RF9816-13 RF9916-13	RFK9816-13 RFK9916-13	MS28775-120	1140-1260
RF9820-13 RF9920-13	RFK9820-13 RFK9920-13	MS28775-123	1520-1680
RF9824-13 RF9924-13	RFK9824-13 RFK9924-13	MS28775-128	1900-2100
	RFK9832-13 RFK9932-13	MS28775-137	2660-2940

25. Engage serrations (9) of fitting (6) with proper wrench from table 1. Tighten fitting to minimum torque from table 2. Make sure serrations of Rosan fitting align with serrations in port.

NOTE

Upon reinstallation of original Rosan fitting, index marks should align.

26. If serrations of lockring (1) and port (8) do not align, slowly increase torque toward maximum until serrations align. Do not exceed maximum torque.
27. Clean port hose. Use solvent (E162).
28. Apply enough zinc chromate primer (E291) to port (8) and below fitting lockring (1) so primer will squeeze serrations during locking installation.

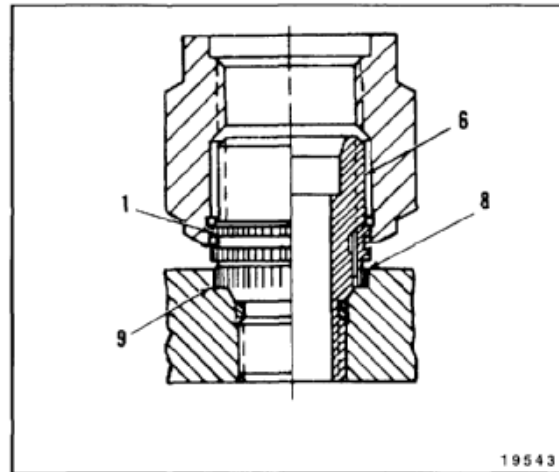

29. Install reducer lockring (1) while zinc chromate primer is still wet as follows:
- Select proper size lockring drive tool RF98-DEK from table 1.
 - Place drive tool over reducer (14). When properly located it will rest on lockring (1).
 - Set lockring (1). Use a hammer, arbor press, or hydraulic press. Installation is complete when tool bottoms on surface of port (8).

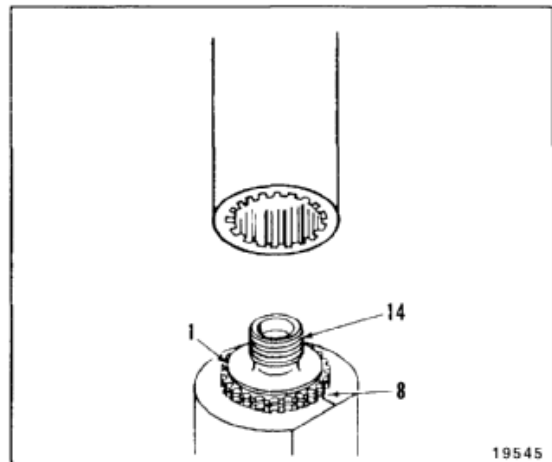

NOTE

Adapter locking (1) may be installed using combination wrench and drive tool (step 30) or locking drive tool (step 31).

30. Install adapter locking (1) while zinc chromate primer is still wet as follows:
- Select proper combination wrench and drive tool RF98-DW from table 1.
 - Rotate combination wrench and drive tool onto fitting (6) until it touches locking (1). Turn the tool until it bottoms on port (8).



Any sudden increase in torque will indicate that locking serrations and port serrations are not aligned.

- Torque fitting (6) per table 2. If serrations (9) cannot be aligned, remove combination wrench and drive tool. Lift locking (1). Repeat step 29.
31. Install adapter locking (1) while zinc chromate primer is still wet as follows:
- Select RF69-TW series wrench from table 1.
 - Place wrench over fitting (6). It is properly located when it rests on locking (1).
 - Select locking drive tool RF98-DK from table 1. Set locking (1). Use a hammer, arbor press, or hydraulic press.
32. Check component for fluid leaks before installing on helicopter.

FOLLOW-ON MAINTENANCE:

None

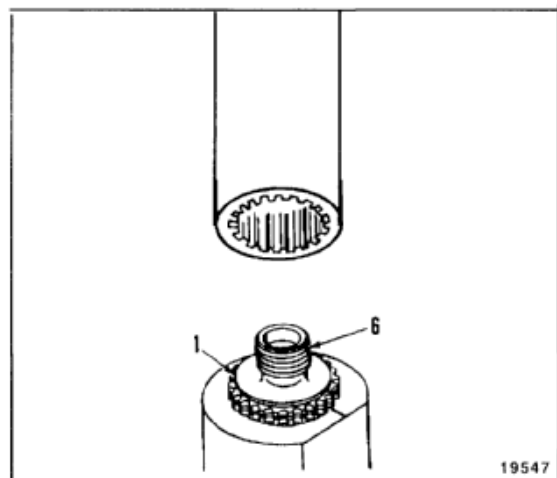
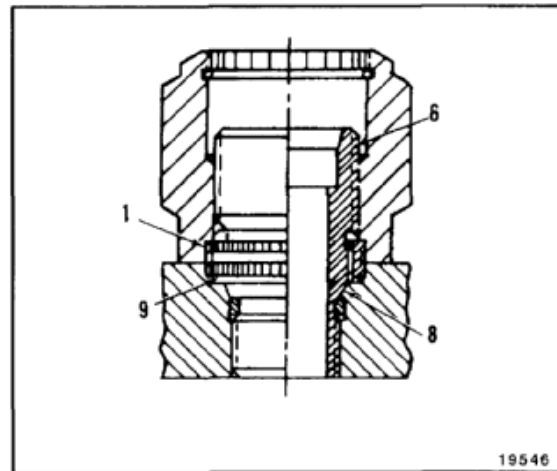

END OF TASK

INITIAL SETUP

Applicable Configurations:

All

Tools:

As Required

Materials:As Required
Cloths (E120)**Parts:**

As Required

Personnel Required:Aircraft Pneudraulics Repairer
Inspector**Equipment Condition:**

As Required

General

1. Hydraulic system leakage can occur at loose connections, faulty components, or dry seals.
2. Seals become dry when hydraulic systems are not used for **one week or longer**. Leakage due to dry seals is referred to as "static leakage."
3. Static leakage usually occurs at actuating cylinders, but can occur at any dynamic seal. Static leakage will be most noticeable during long storage of helicopter. By itself, static leakage is not cause for replacing a component. The component should be tested to see if the static leakage exceeds allowable limits (Task 7-123.2).
4. Sudden changes in temperature can increase static leakage.
5. Pressurized reservoirs can increase static leakage.
6. Static leakage can be corrected by cycling system long enough to wet seals. Wipe components and surrounding areas clean. Use clean cloths (E120).
7. Leakage is not permitted for seals at joining faces or on non-moving parts.
8. Allowable leakage is:
 - a. Dynamic seals.
 - (1) Static condition — **1 drop in 10 minutes** at each seal.
 - (2) Operating condition — **1 drop in 25 cycles** at each seal.
 - b. Static seals at tubing joints, hoses, or seals — no leakage allowed.

Specific

9. For specific leakage criteria refer to the following tasks:
 - Task 7-26 TEST FLIGHT CONTROL AND UTILITY HYDRAULIC PUMP (AVIM).
 - Task 7-50 TEST ACCUMULATOR (2770529 OR AD-A620-1D340) (AVIM).
 - Task 7-71 TEST PUMP SHAFT SEAL (570974) (AVIM).
 - Task 7-76 TEST MOTOR SHAFT SEAL (570973) (AVIM).
 - Task 7-97 EXTENSIBLE LINK ACTUATOR CYLINDER FUNCTIONAL TEST (AVIM).
 - Task 7-98 TEST PITCH, ROLL, YAW, OR THRUST INTEGRATED LOWER CONTROL ACTUATOR (ILCA) (AVIM).
 - Task 7-116 TEST FLIGHT CONTROL RESERVOIR/COOLER (AVIM).
 - Task 7-123.2 CHECK PIVOTING AND SWIVELING SERVOCYLINDER CONTROL VALVES FOR LEAKAGE.
 - Task 7-146 TEST APU MOTOR PUMP (68WK02005-4) (AVIM).
 - Task 7-177 TEST ACCUMULATORS (60910, HP1323100, OR AD-B130-1D390) (AVIM).
 - Task 7-192 TEST TRANSFER CYLINDER (AVIM).
 - Task 7-217 TEST UTILITY RESERVOIR/COOLER (AVIM).
 - Task 7-228 TEST BRAKE MASTER CYLINDER (AVIM).
 - Task 7-235 TEST BRAKE TRANSFER VALVE (AVIM).
 - Task 7-243 TEST ACCUMULATOR (1356-643887M1) (AVIM).
 - Task 7-264 TEST HOOK RELEASE VALVE (AVIM).
 - Task 7-269 TEST CARGO RAMP CONTROL VALVE (AVIM).
 - Task 7-280 TEST CARGO DOOR SEQUENCE VALVE (AVIM).

Task 7-283.5 TEST CARGO DOOR PRESSURE ACTUATED VALVE.

Task 7-288 TEST CARGO DOOR ACTUATOR MOTOR (AVIM).

Task 7-313 TEST SWIVEL LOCK ACTUATOR (AVIM).

NOTE

Due to allowable static and dynamic leakage of pivoting and swiveling actuators (145H6600 and 145H6700 series), hydraulic fluid may leak from the input shaft rubber boot (145HS003) during actuator operation. The allowable static leakage for actuator control valve assemblies is **2 drops per minute** per actuator. The allowable dynamic leakage for actuator control valve assemblies is **4 drops per 25 cycles** per actuator. One cycle equals one full extension and retraction of the actuator.

A combination of dynamic leakage during operation and static leakage may cause hydraulic fluid to leak from the rubber boot around the input shaft housing. This condition alone is not cause for replacing an actuating cylinder. See Task 7-123.2 for leakage criteria.

FOLLOW-ON MAINTENANCE:

As Required

END OF TASK

INITIAL SETUP

Applicable Configurations:

All

Tools:

None

Materials:

None

Personnel Required:

Inspector

References:

- Task 7-33
- Task 7-34
- Task 7-156
- Task 7-157
- Task 7-194
- Task 7-195
- FM 1-509

Equipment Condition:

- Battery Disconnected (Task 1-39)
- Electrical Power Off
- Hydraulic Power Off
- Right Forward Work Platform Open (Task 2-2)
- Pylon Right Access Door Open (Task 2-2)
- Cargo Ramp Open and Level (TM 55-1520-240-10)

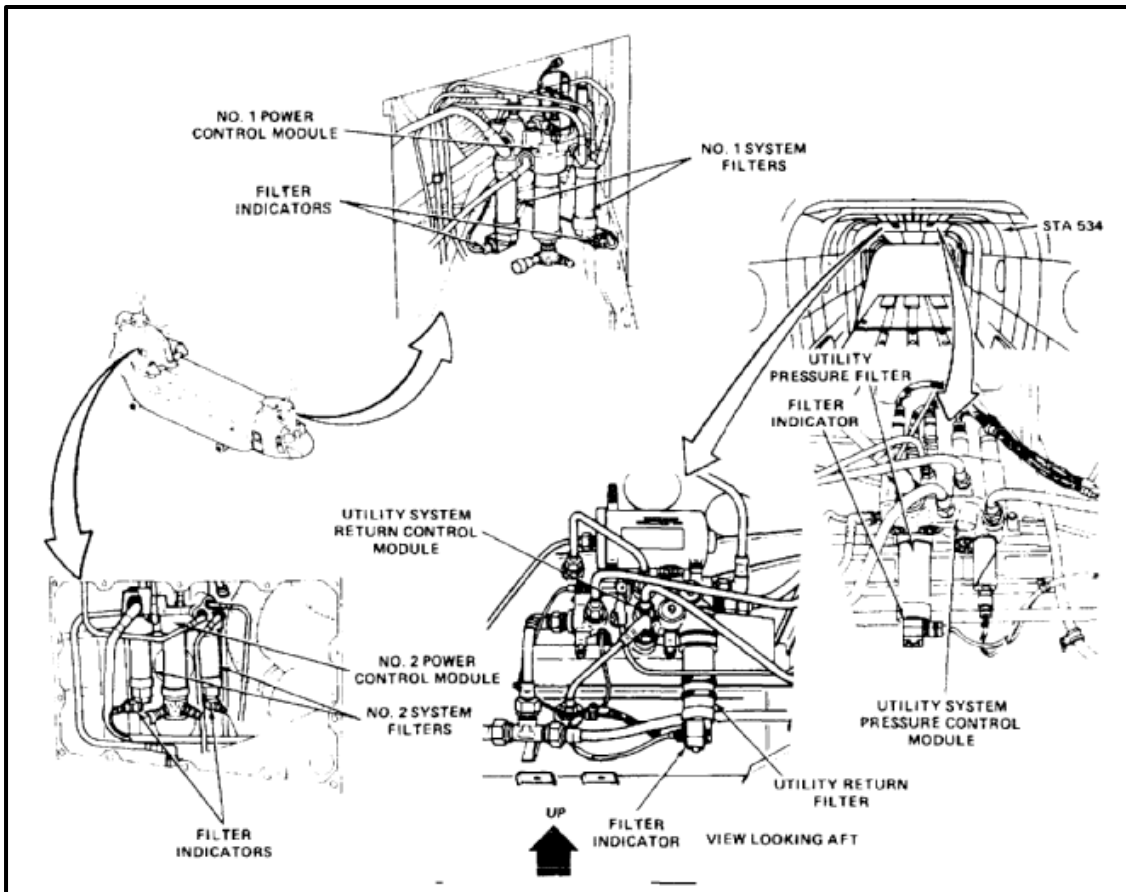

7-8 INSPECT FOR CONTAMINATION OF HYDRAULIC SYSTEMS (Continued)

7-8

1. Check all six hydraulic filters (1). Inspect that red indicator button (2) on bottom of each filter has not extended.
2. If button (2) is extended, apply hydraulic power to that system.
3. Depress button (2). If checking utility system, have pilot in cockpit motor either engine for **30 seconds**. If checking flight control system, have pilot in cockpit cycle control stick for **30 seconds**. If button extends, filter element is clogged.
4. Remove hydraulic power.
5. Remove filter element on all contaminated filters (Tasks 7-33, 7-156, and 7-194 as required).
6. Inspect removed element and determine source of contamination (FM 1-509).
7. Install new filter element (Task 7-34, 7-157, or 7-195 as required).

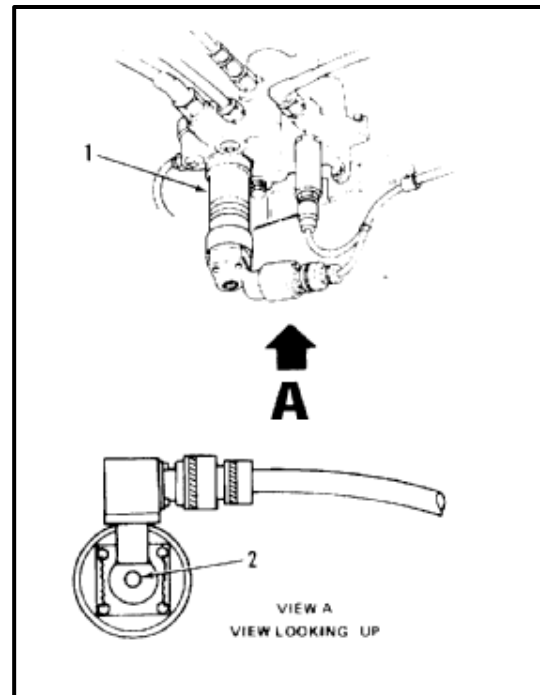
**FOLLOW-ON MAINTENANCE:**

- As required.
- Close right forward walk platform (Task 2-2).
- Close pylon right access door (Task 2-2).

END OF TASK

7-8.1 SAMPLE HYDRAULIC FLUID FROM FLIGHT CONTROL AND UTILITY SYSTEM RESERVOIR/COOLERS

7-8.1

INITIAL SETUP

Applicable Configurations:

All

Tools:

- Hydraulic Repairer's Tool Kit, NSN 5180-00-323-4891
- Sampling Bottle (3) (Refer to TB 43-0106)
- Sampling Tube (3) (Refer to TB 43-0106)
- Container, 2 Quart
- Workstand

Materials:

- Cloths (E135)
- Gloves (E186)

Personnel Required:

- Army Aviator (2)
- Aircraft Pneudraulics Repairer
- Inspector

References:

TB 43-0106

Equipment Condition:

- Perform 15 Minute Ground Run (TM 55-1520-240-10)
- Battery Disconnected (Task 1-39)
- Electrical Power Off
- Hydraulic Power Off
- Right and Left Pylon Access Panel Open (Task 2-2)
- Right Forward Work Platform Open (Task 2-2)

General Safety Instructions:

WARNING

Hydraulic fluid (E199) is toxic. It can irritate skin and cause burns. Avoid inhaling. Use only with adequate ventilation. Avoid contact with skin, eyes, or clothing. In case of contact, immediately flush skin or eyes with water for at least **15 minutes**. Get medical attention for eyes.

WARNING

Hydraulic fluid ejected under pressure can cause injury to personnel. Hydraulic fluid sprayed into the air is a fire hazard.

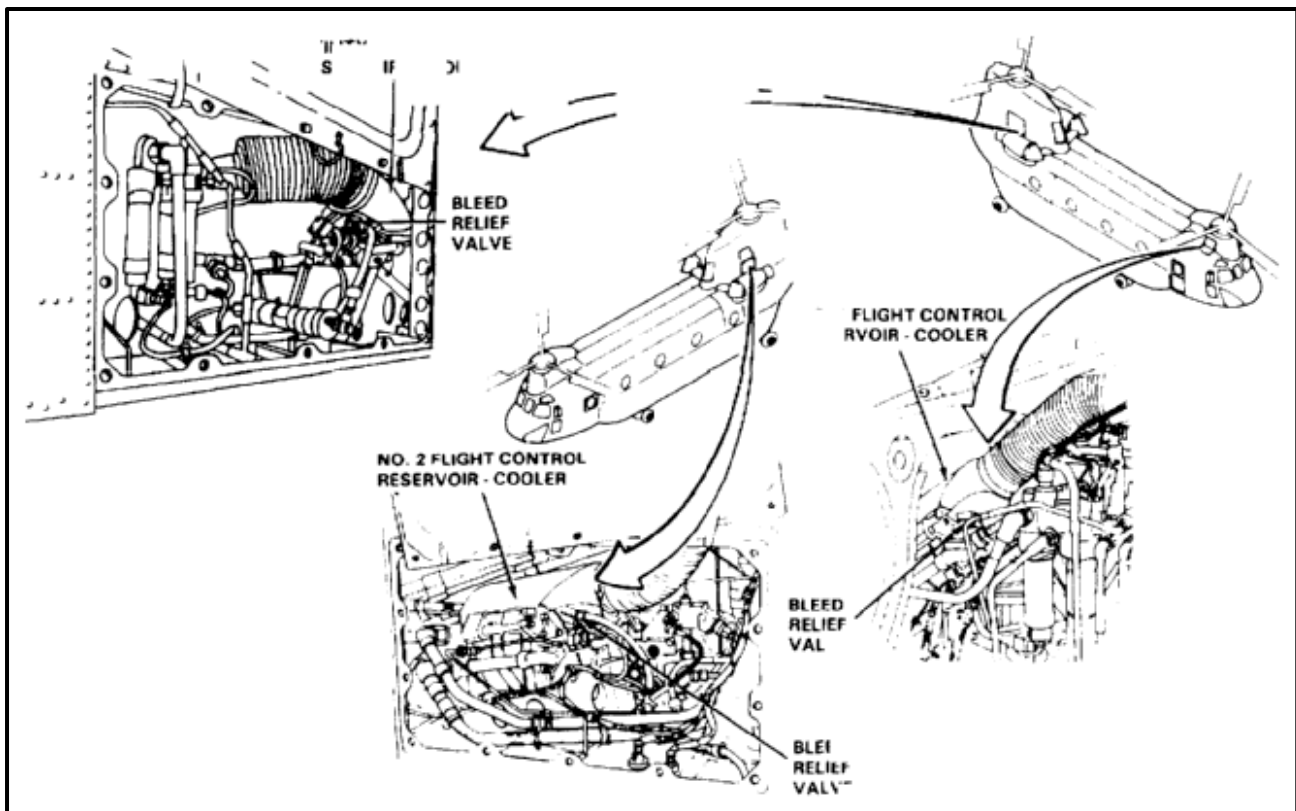

**7-8.1 SAMPLE HYDRAULIC FLUID FROM FLIGHT CONTROL AND UTILITY SYSTEM
RESERVOIR/COOLERS (Continued)**

7-8.1



Samples must be taken directly after system has been operating for at least **15 minutes**. Otherwise, sample may not be reliable and component malfunction can occur.

1. Loosen clamp (1) on hose (2). Disconnect hose from bleed relief valve (3) of utility reservoir/cooler (4).
2. Connect sampling tube (5) to valve (3). Install clamp (6) on tube.
3. Place container (7) under tube (5) open end.
4. Remove cap (8) from sample bottle (9). Place cap upside down on clean surface.
5. Turn lever (10) to open valve (3). Bleed approximately **1 pint** of fluid into container (7), then place bottle (9) under tube (5) open end. Fill to within **1/2 inch** of bottle top. Wear gloves (E186).
6. Close valve (3).
7. Install cap (8) on bottle (9). Wipe bottle. Use cloths (E135).
8. Record sampling data. (Refer to TB 43-0106.)
9. Remove clamp (6) from tube (5). Disconnect tube from valve (3). Use cloths (E135) for spilled fluid.
10. Connect hose (2) to valve (3). Tighten clamp (1).
11. Repeat steps 1 thru 10 for No. 1 and No. 2 flight control reservoir/cooler.

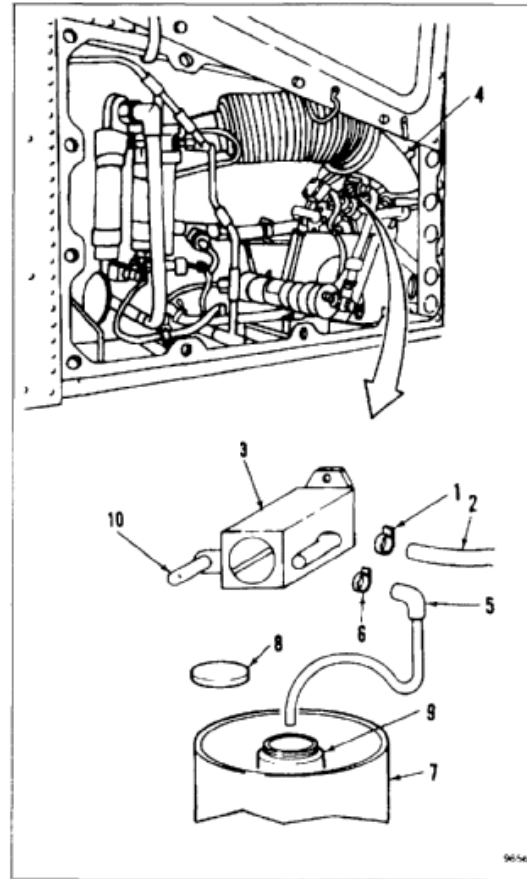
INSPECT
FOLLOW-ON MAINTENANCE:

Close right and left pylon access panels (Task 2-2).
Close right forward work platform (Task 2-2).
Service reservoir/coolers (Tasks 1-50, 1-59, 1-60,
and 1-61).

END OF TASK

INITIAL SETUP

Applicable Configurations:

All

Tools:

- Hydraulic Repairer's Tool Kit, NSN 5180-00-323-4891 Container
- Hydraulic Test Stand
- Filter Assembly Kit ADHT6814-M9716M

Materials:

- Hydraulic Fluid) (E199)
- Cloths (E120)
- Gloves (E186)

Parts:

- Unions
- Tees
- Fittings
- Hoses

Personnel Required:

Aircraft Pnedraulics Repairer (2)

References:

- TM 55-4920-335-14 or
- TM 55-4920-373-14&P

Equipment Condition:

- Battery Disconnected (Task 1-39)
- Hydraulic Power Off
- Forward Work Platforms Open (Task 2-2)
- Aft Work Platforms Open (Task 2-2)
- Flight Control Hydraulic Systems Depressurized (Task 1-63)
- Lower Controls Actuator Structural Manifold Removed (Task 7-103)
- Forward Transmission Drip Pan Removed (Task 2-3)
- Left Transmission Baffle Open (Task 2-2)
- Cargo Ramp Open and Level (TM 55-1520-240-10)
- Left and Right Pylon Access Doors Open (Task 2-2)
- No. 1 Power Control Module Removed (Task 7-29)
- No. 2 Power Control Module Removed (Task 7-31)
- No. 1 and No. 2 Flight Control Lower Controls Modules Removed (Task 7-78)

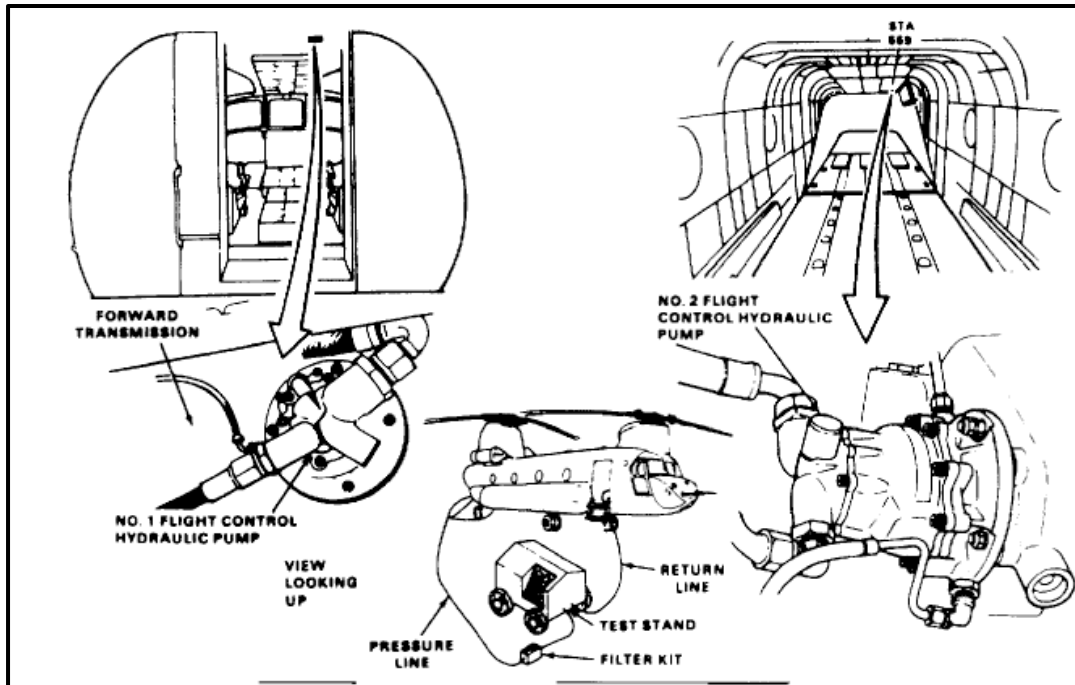

7-9 PREPARE FLIGHT CONTROL HYDRAULIC SYSTEM FOR FLUSHING (PRESSURE LINES) (Continued)

7-9

WARNING

Hydraulic fluid (E199) is toxic. It can irritate skin and cause burns. Avoid inhaling. Use only with adequate ventilation. Avoid contact with skin, eyes, or clothing. In case of contact, immediately flush skin or eyes with water for at least **15 minutes**. Get medical attention for eyes.

WARNING

Hydraulic fluid ejected under pressure can cause injury to personnel. Hydraulic fluid sprayed into the air is a fire hazard.

NOTE

Test stand filters must be cleaned before connecting test stand to helicopter.

Make sure filter assembly kit ADHT6814-M9716M is installed in test stand pressure line.

NO. 2 PUMP

1. Disconnect pressure line (1) from No. 2 flight control pump (2). Cap open port (3) on pump. Use gloves (E186).
2. Attach pressure line (4) from test stand to pressure line (1). Use union (5).

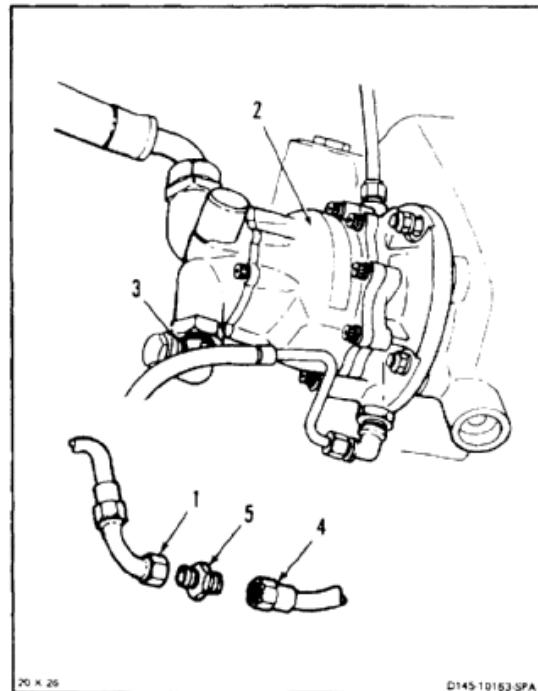

20 X 26

D145-10163-SPA

AFT SERVOCYLINDERS

NOTE

Pivoting servocylinder is reached from left work platform. Swiveling servocylinder is reached from right work platform. Pivoting servocylinder only shown here.

3. Disconnect hoses (6, 7) from elbows (8, 9) on both pivoting and swiveling servocylinders (10). Cap open ports on servocylinders.
4. Connect hoses (6) to hoses (7) with test (11) and fittings (12).

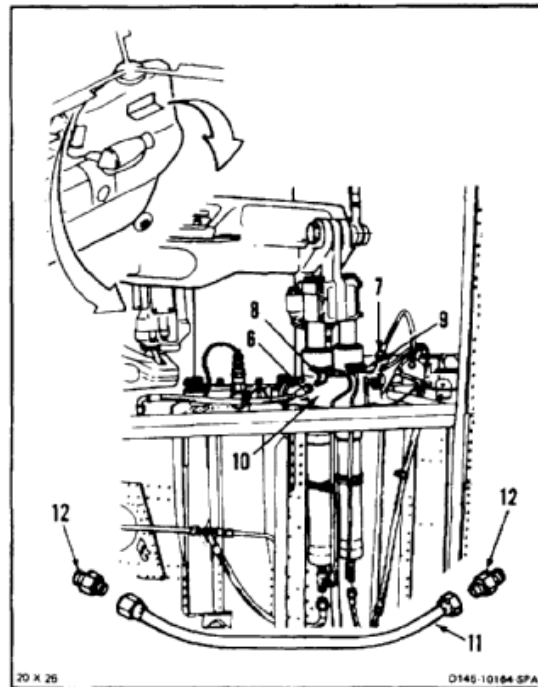

NO. 2 POWER CONTROL MODULE

5. Connect pump pressure line (13) to system pressure line (14) with test hose (15) and fittings (16).

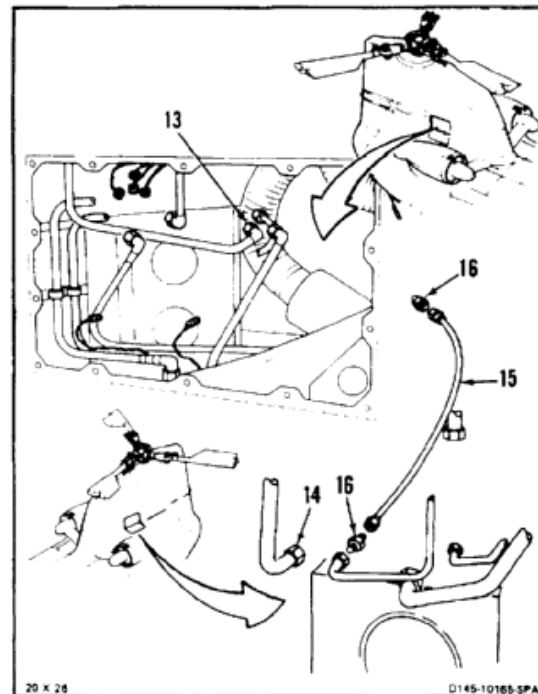

7-9 PREPARE FLIGHT CONTROL HYDRAULIC SYSTEM FOR FLUSHING (PRESSURE LINES) (Continued)

NO. 1 AND NO. 2 LOWER CONTROLS MODULES

NOTE

Procedure is same at both No. 1 and No. 2 lower controls module locations. No. 2 module location shown.

6. Connect pressure in line (17) to pressure out line (18) with test hose (19), tee fitting (20) and fittings (21).
7. Connect tee fitting (20) to AFCS pressure line (22) with test hose (23) and fittings (24).
8. Repeat steps 6 and 7 at No. 1 module location.

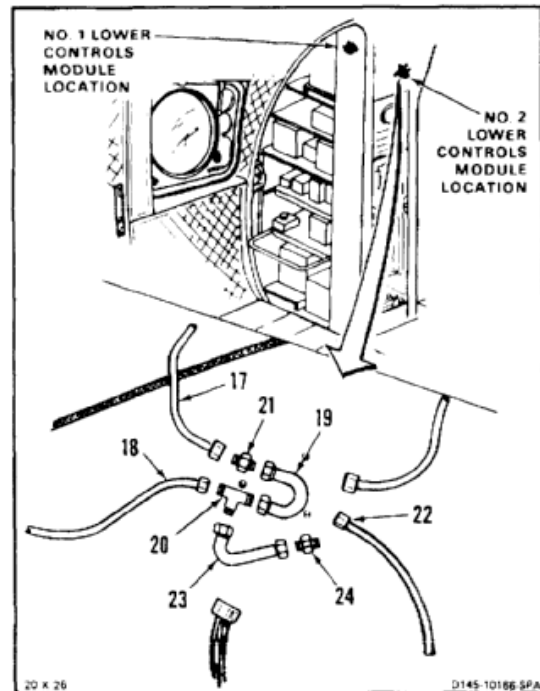

LOWER CONTROLS ACTUATORS

9. Connect AFCS 1 pressure line (25) to AFCS 2 pressure line (26) with test hose (27) and fittings (28).
10. Connect No. 1 pressure line (29) to No. 2 pressure line (30) with test hose (31) and fittings (32).

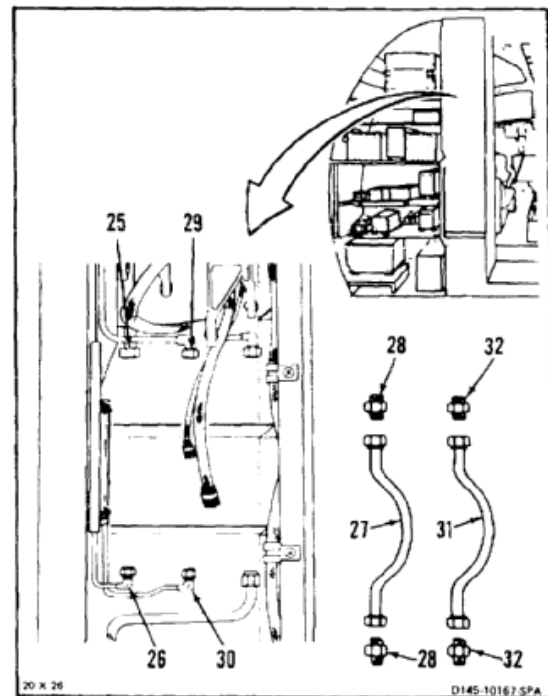

NO. 1 POWER CONTROL MODULE

11. Connect pump pressure line (33) to system pressure line (34) with test hose (35) and fittings (36).

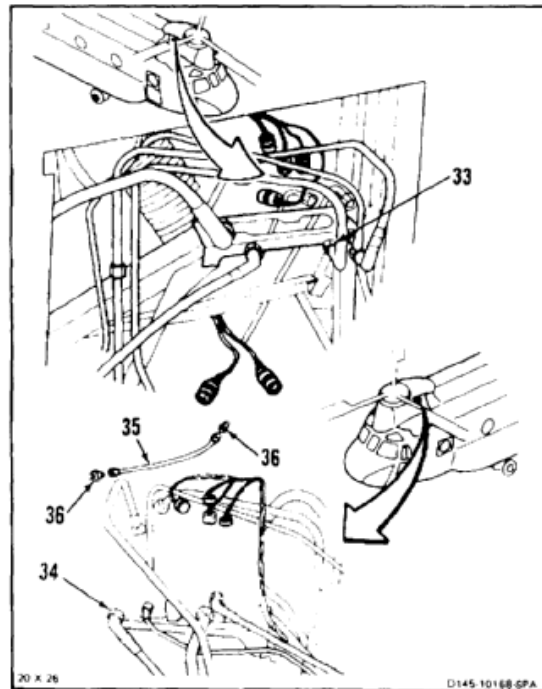

FORWARD SERVOCYLINDERS

NOTE

Pivoting servocylinder is reached from right work platform. Swiveling servocylinder is reached from left work platform. Pivoting servocylinders only shown here.

12. Remove hoses (37, 38) from elbows (39, 40) on both pivoting and swiveling servocylinders (41). Cap open ports on servocylinders.
13. Connect hoses (37) to hoses (38) with test hoses (42) and fittings (43).

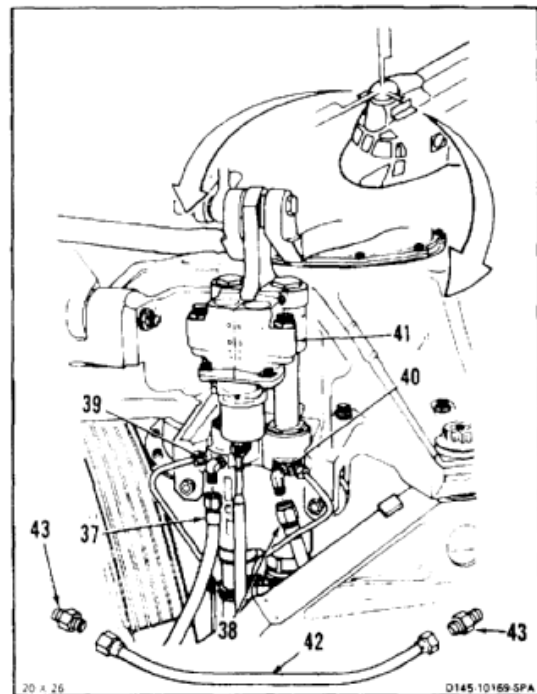

7-9 PREPARE FLIGHT CONTROL HYDRAULIC SYSTEM FOR FLUSHING (PRESSURE LINES) (Continued)

7-9

NO. 1 PUMP

14. Remove pressure line (44) from No. 1 flight control pump (45). Cap open port (46) on pump.
15. Attach return line (47) from test stand to pressure line (44) with union (48).

FOLLOW-ON MAINTENANCE:

Flush flight control system pressure lines (Task 7-10).

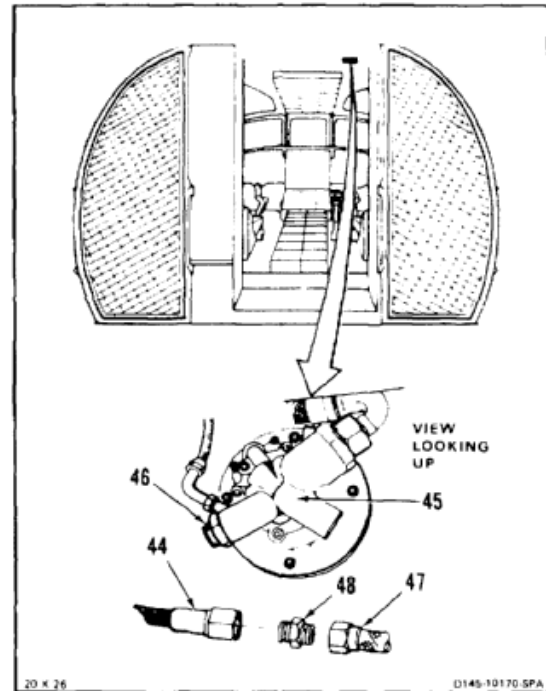

END OF TASK

INITIAL SETUP

Applicable Configurations:

All

Tools:

Hydraulics Repairer's Tool Kit, NSN
5180-00-323-4891
Containers
Hydraulic Test Stand
Filter Assembly Kit ADHT6814-M9716M

Materials:

Hydraulic Fluid (E199)
Cloths (E120)
Gloves (E184.1)

Parts:

Hoses
Fittings
Unions

Personnel Required:

Aircraft Pneudraulics Repairer
Inspector

Equipment Condition:

Flight Control System Prepared for Flushing (Task
7-9)

General Safety Instructions:**WARNING**

Hydraulic fluid (E199) is toxic. It can irritate skin and cause burns. Avoid inhaling. Use only with adequate ventilation. Avoid contact with skin, eyes, or clothing. In case of contact, immediately flush skin or eyes with water for at least **15 minutes**. Get medical attention for eyes.

WARNING

Hydraulic fluid ejected under pressure can cause injury to personnel. Hydraulic fluid sprayed into the air is a fire hazard.

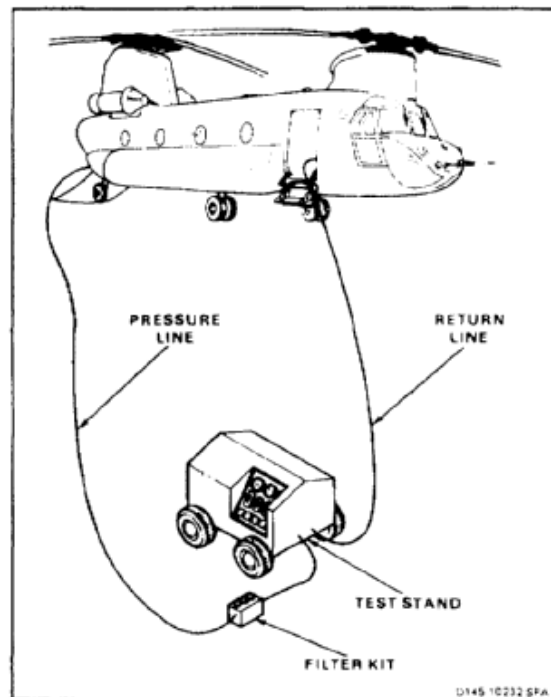

NOTE

Test stand filters must be cleaned before connecting test stand to helicopter.

Make sure filter assembly kit ADHT6814-M9716M is installed in test stand pressure line.

To operate hydraulic test stand, refer to applicable manual.

1. Open shutoff valve in test stand return line.



Keep test stand bypass valve closed. Otherwise, contaminants could reenter the system.

2. Set test stand to deliver **10 gpm at 500 psi** pressure.
3. Start test stand and slowly fill lines with hydraulic fluid. Check system for leaks.
4. Flush system for **5 minutes** to make sure system is filled.
5. Shut down test stand.
6. At No. 2 lower controls module location, remove bypass hose (1) from pressure line (2). Plug and cap both lines. Wear gloves (E184.1).

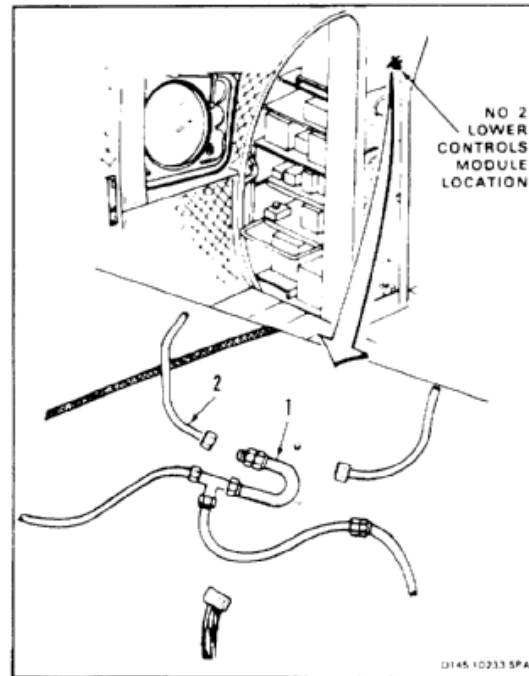

FLUSHING FORWARD UPPER CONTROLS PRESSURE SYSTEM**NOTE**

Forward pivoting servocylinder is reached from right work platform.
 Forward swiveling servocylinder is reached from left work platform.
 Pivoting servocylinder only shown here.

7. Remove bypass hoses (3) from pressure lines (4 and 5) at both forward servocylinders (6).
8. Plug pressure lines (4 and 5).



Keep test stand bypass valve closed.
 Otherwise, contaminants could reenter the system.

9. Turn on test stand. Set stand to **10 gpm at 500 psi**. Slowly increase stand pressure to **700 psi** and hold for **15 minutes**. Check for leaks.
10. Reduce pressure and shut down test stand.
11. Remove plugs from pressure lines (4 and 5).
12. Connect bypass hose (3) to pressure lines (4 and 5).

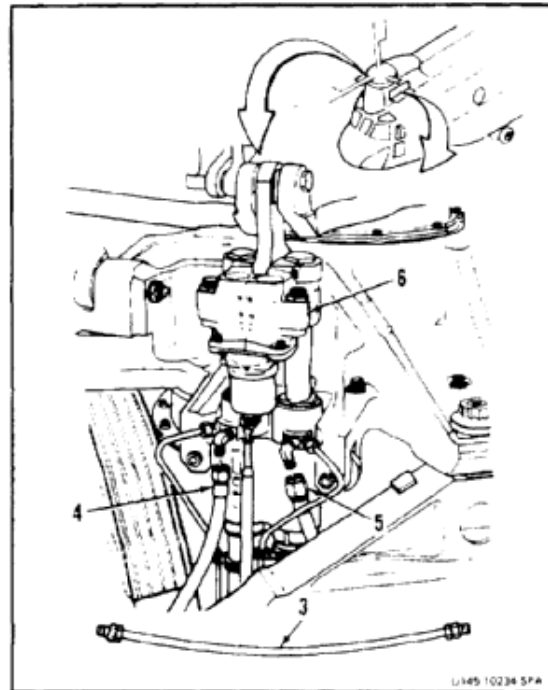
**FLUSHING AFT UPPER CONTROLS PRESSURE SYSTEM****NOTE**

Aft pivoting servocylinder is reached from left work platform. Aft swiveling servocylinder is reached from right work platform. Pivoting servocylinder only shown here.

13. Remove bypass hoses (7) from pressure lines (8 and 9) at both aft servocylinders (10).
14. Plug pressure lines (8 and 9).
15. Repeat steps 9 and 10.

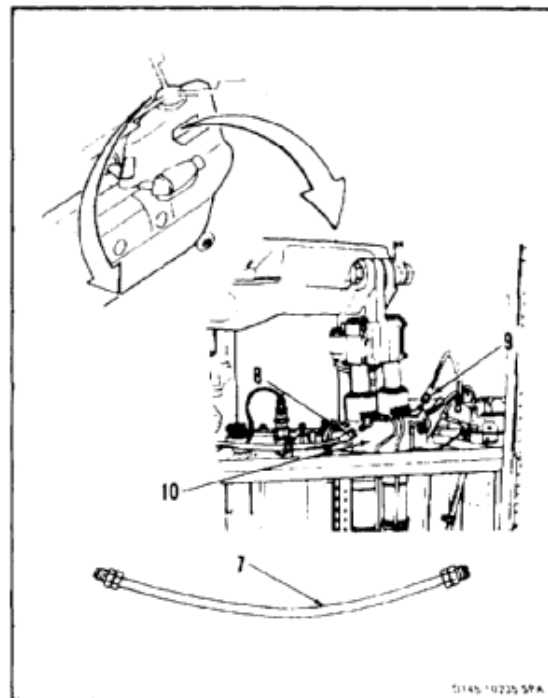

FLUSHING LOWER CONTROLS PRESSURE SWITCH

16. Repeat steps 7 and 8.
17. Remove plug from pressure line (2). Remove cap from bypass hose (1).
18. Connect bypass hose (1) to pressure line (2).
19. Repeat steps 9 and 10.

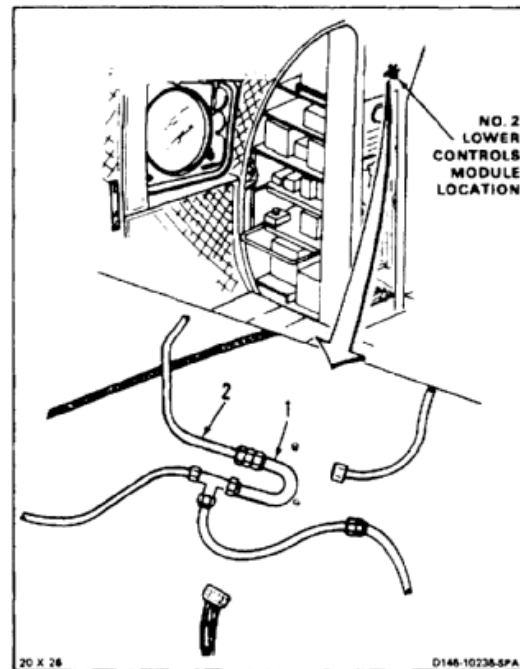
***FOLLOW-ON MAINTENANCE:***

Prepare flight control hydraulic system after flushing (pressure lines) (Task 7-11).

END OF TASK

INITIAL SETUP

Tools:

- Hydraulic Repairer's Tool Kit, NSN 5180-00-323-4891
- Container
- Hydraulic Test Stand
- Filter Assembly Kit ADHT 6814-M9716M
- Workstand

Materials:

- Cloths (E120)
- Gloves (E186)

Parts:

- Hoses
- Unions
- Fittings

Personnel Required:

- Aircraft Pseudraulic Repairer
- Inspector

Equipment Condition:

Flushing Flight Control Hydraulic System (Pressure Lines) Completed (Task 7-10)

General Safety Instructions:

WARNING

Hydraulic fluid (E199) is toxic. It can irritate skin and cause burns. Avoid inhaling. Use only with adequate ventilation. Avoid contact with skin, eyes, or clothing. In case of contact, immediately flush skin or eyes with water for at least **15 minutes**. Get medical attention for eyes.

WARNING

Hydraulic fluid ejected under pressure can cause injury to personnel. Hydraulic fluid sprayed into the air is a fire hazard.

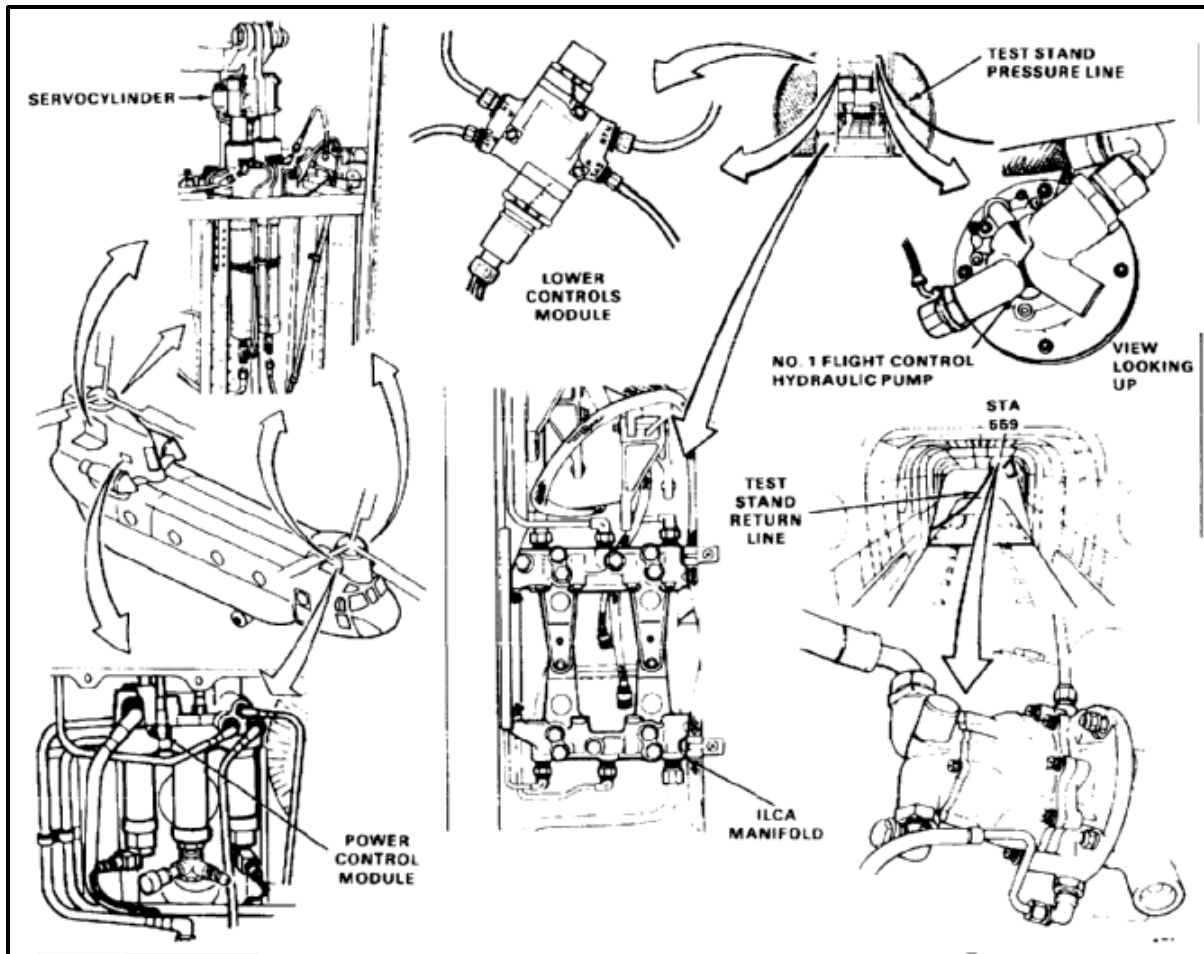

7-11 PREPARE FLIGHT CONTROL HYDRAULIC SYSTEM AFTER FLUSHING (PRESSURE LINES) (Continued)

7-11

NO. 1 PUMP

1. Remove test stand return line (1) and union (2) from No. 1 pump pressure line (3). Use gloves (E186).
2. Remove cap from pressure port (4) of No. 1 pump (5).
3. Connect line (3) to pressure port (4).

INSPECT

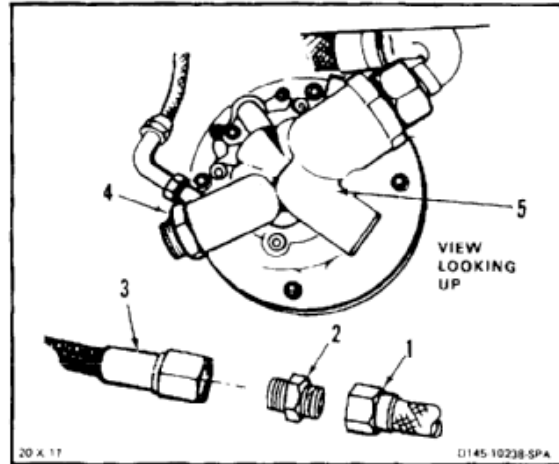

FORWARD SERVOCYLINDERS

NOTE

Pivoting servocylinder is reached from right work platform. Swiveling servocylinder is reached from left work platform. Pivoting servocylinder only is shown here.

4. Remove plugs from pressure hoses (6 and 7) at both forward servocylinders (8).
5. Remove four caps from elbows (9 and 10) on both servocylinders (8).
6. Connect pressure hoses (6) to elbows (9) and pressure hoses (7) to elbows (10).

INSPECT

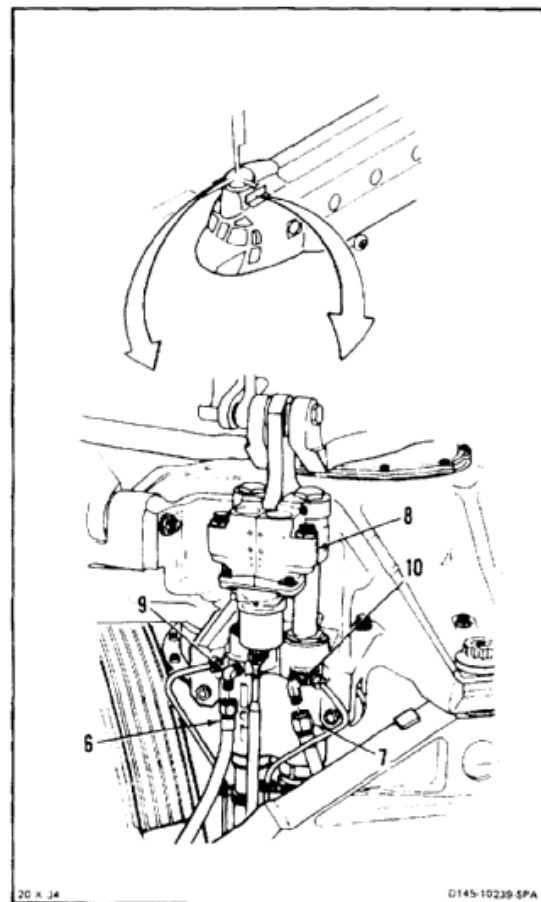

NO. 1 POWER CONTROL MODULE

7. Remove test hose (11) and fittings (12) from pump pressure line (13) and system pressure line (14). Plug lines.

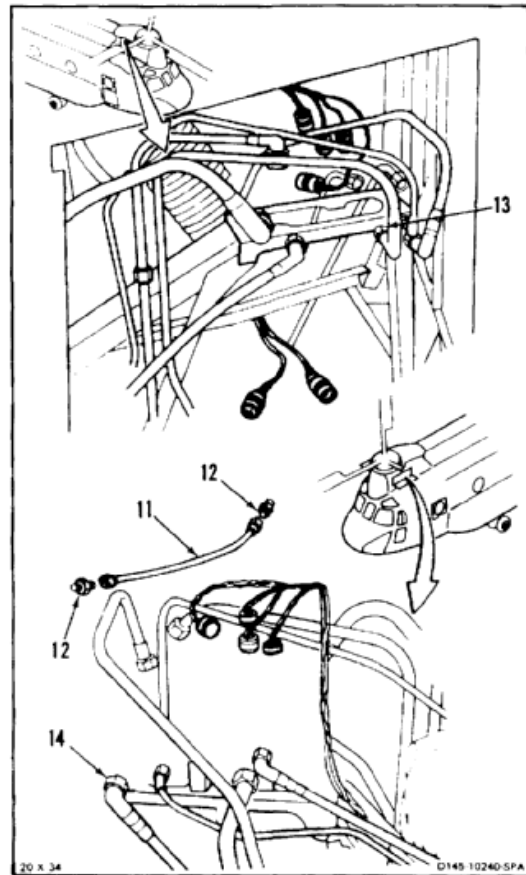
INSPECT

7-11 PREPARE FLIGHT CONTROL HYDRAULIC SYSTEM AFTER FLUSHING (PRESSURE LINES) (Continued)

7-11

LOWER CONTROLS ACTUATORS

8. Remove bypass hose (15) and fittings (16) from AFCS 1 pressure line (17) and AFCS 2 pressure line (18). Plug lines.
9. Remove bypass hose (19) and fittings (20) from No. 1 pressure line (21) and No. 2 pressure line (22). Plug lines.

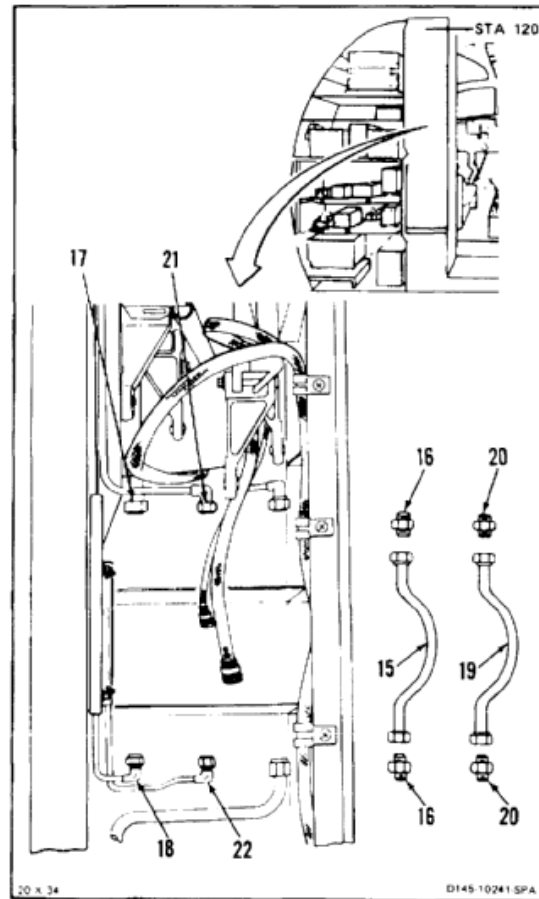
INSPECT

NO. 2 LOWER CONTROLS MODULES

10. Remove test hose (23) from tee fitting (24) and from AFCS pressure line (25).
11. Remove test hose (26) and tee fitting (24) from pressure out line (27). Plug open lines.

INSPECT

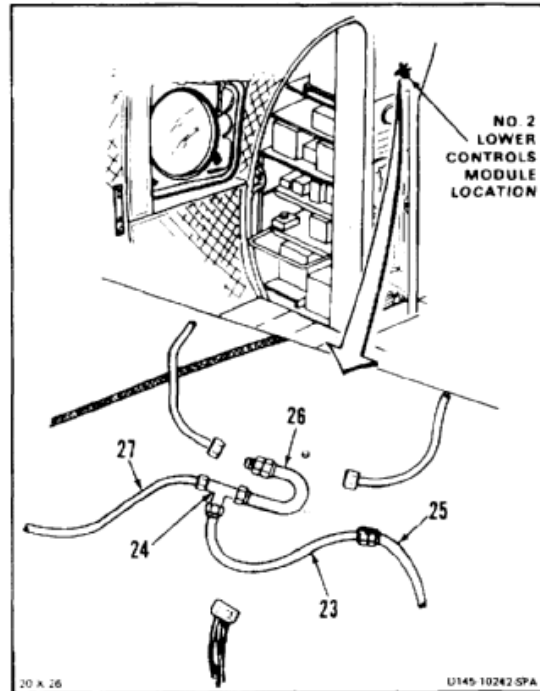

NO. 1 LOWER CONTROLS MODULE

12. Remove test hose (28) from tee fitting (29).
13. Remove test hose (28) and fitting (30) from AFCS pressure line (31).
14. Remove test hose (32) and fitting (33) from pressure in line (34).
15. Remove test hose (32) from tee fitting (29).
16. Remove tee fitting (29) from pressure out line (35). Plug all lines.

INSPECT

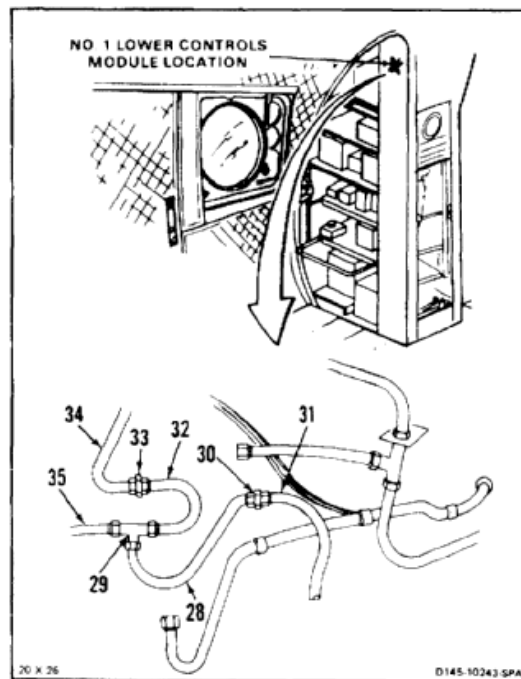

7-11 PREPARE FLIGHT CONTROL HYDRAULIC SYSTEM AFTER FLUSHING (PRESSURE LINES) (Continued)

7-11

NO. 2 POWER CONTROL MODULE

17. Remove test hose (36) and fittings (37) from pump pressure line (38) and from system pressure line (39).

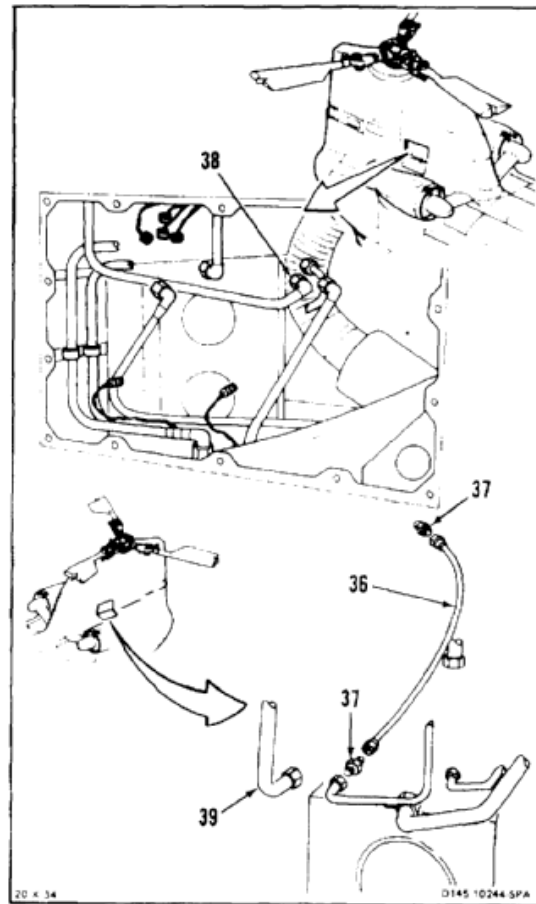
INSPECT

AFT SERVO CYLINDERS
NOTE

Pivoting servocylinders is reached from left work platform. Swiveling servocylinder is reached from right work platform. Pivoting servocylinder only shown here.

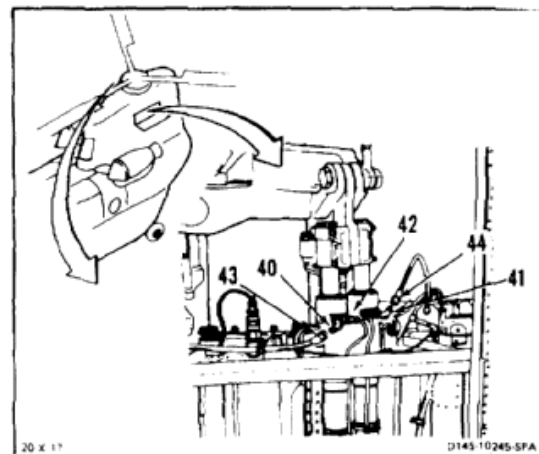
18. Remove four caps from elbows (40 and 41) on both pivoting and swiveling servocylinders (42).
19. Remove plugs from pressure hoses (43 and 44) at both servocylinders (42).
20. Connect pressure hoses (43) to elbows (40) and pressure hoses (44) to elbows (41).

INSPECT

NO. 2 PUMP

21. Disconnect test stand pressure line (45) and union (46) from pump pressure line (47).
22. Remove cap (48) from pressure port (49) of No. 2 flight control pump (50).
23. Connect pressure line (47) to pressure port (49).
24. Remove all test hoses and fittings from helicopter.
25. Remove filter assembly kit from test stand pressure hose.

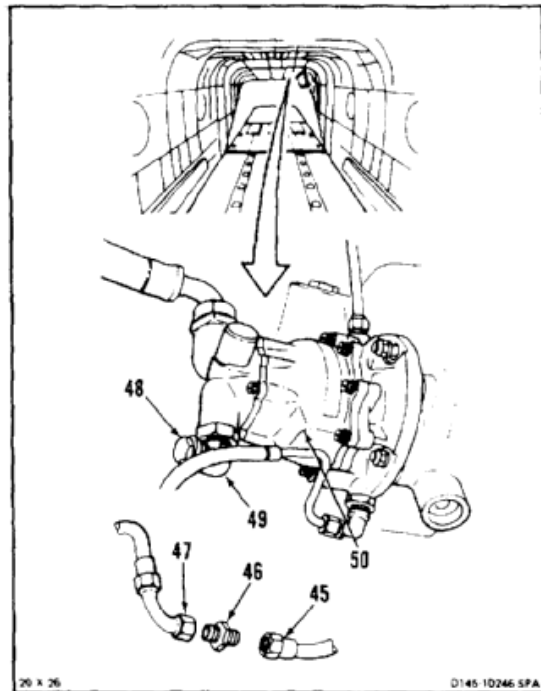
INSPECT**FOLLOW-ON MAINTENANCE:**

- Install No. 1 and No. 2 flight control lower controls module (Task 7-79).
- Install No. 1 power control module (Task 7-30).
- Install No. 2 power control module (Task 7-32).
- Install lower controls actuator structural manifold (Task 7-104).
- Install integrated lower controls actuators (ILCA) (Task 7-102).
- Bleed flight control hydraulic system (Task 7-16).
- Close aft work platforms (Task 2-2).
- Close forward work platforms (Task 2-2).
- Install forward transmission drip pan (Task 2-3).
- Close pylon access doors (Task 2-2).
- Close left transmission baffle (Task 2-2).
- Perform operational check of flight control hydraulic system (TM 55-1520-240-T).

END OF TASK

7-12 PREPARE FLIGHT CONTROL HYDRAULIC SYSTEM FOR FLUSHING (RETURN LINES)

7-12

INITIAL SETUP

Applicable Configurations:

All

Tools:

- Hydraulic Repairer's Tool Kit, NSN 5180-00-323-4891
- Containers
- Hydraulic Test Stand
- Filter Assembly Kit ADHT6814-M9716M
- Workstand

Materials:

- Hydraulic Fluid (E199)
- Cloths (E120)
- Gloves (E186)

Parts:

- Test Hoses
- Fittings
- Unions

Personnel Required:

Aircraft Pneudraulics Repairer (2)

Equipment Condition:

- Battery Disconnected (Task 1-39)
- Electrical Power Off
- Hydraulic Power Off
- Forward Transmission Drip Pan Removed (Task 2-3)
- Aft Work Platforms Open (Task 2-2)
- Pylon Access Doors Open (Task 2-2)
- Forward Work Platforms Open (Task 2-2)
- Left Transmission Baffle Open (Task 2-2)
- No. 1 Power Control Module Removed (Task 7-29)
- No. 2 Power Control Module Removed (Task 7-31)
- Lower Controls Actuator Structural Manifold Removed (Task 7-103)
- No. 1 and No. 2 Flight Control Lower Controls Modules Removed (Task 7-78)
- No. 1 and No. 2 Flight Control Reservoir/Coolers Removed (Task 7-113)

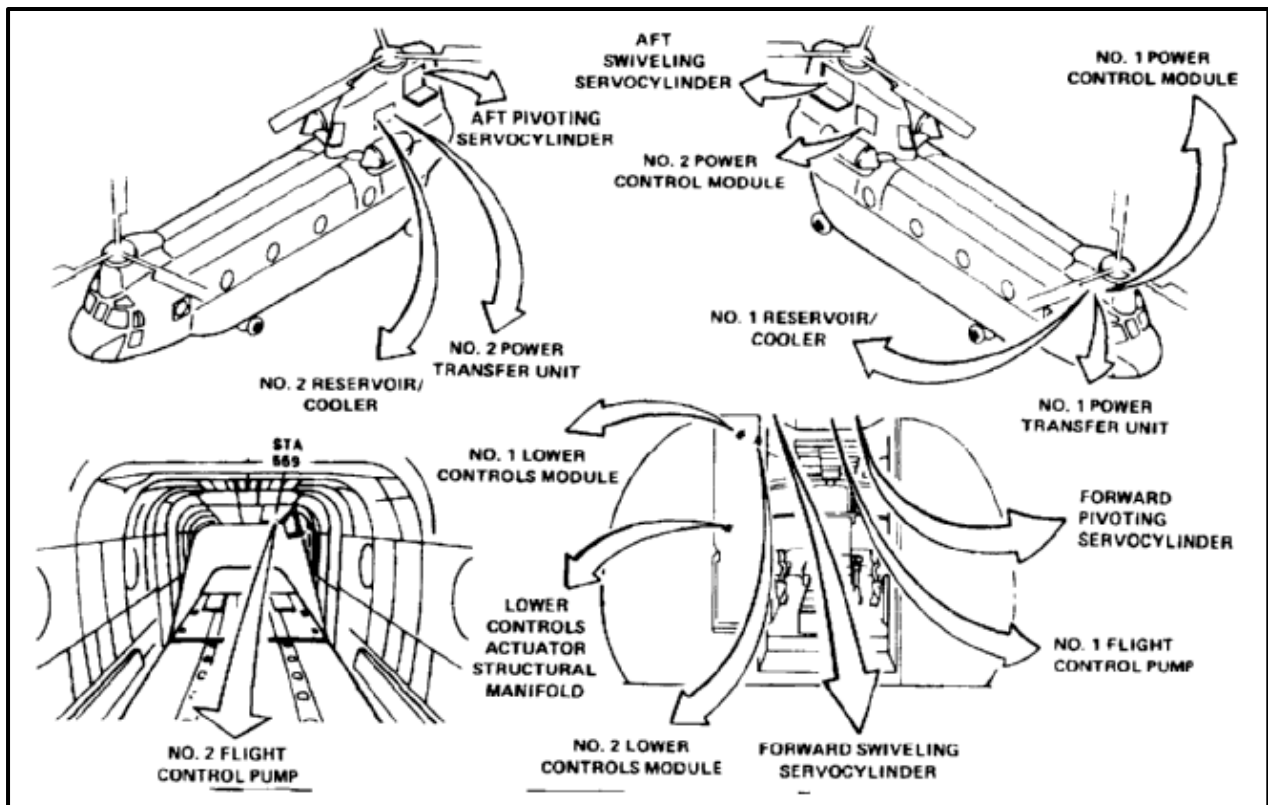

WARNING

Hydraulic fluid (E199) is toxic. It can irritate skin and cause burns. Avoid inhaling. Use only with adequate ventilation. Avoid contact with skin, eyes, or clothing. In case of contact, immediately flush skin or eyes with water for at least **15 minutes**. Get medical attention for eyes.

WARNING

Hydraulic fluid ejected under pressure can cause injury to personnel. Hydraulic fluid sprayed into the air is a fire hazard.

NOTE

Test stand filters must be cleaned before connecting test stand to helicopter.

Make sure filter assembly kit ADHT6814-M9716M is installed in test stand pressure line.

NO. 2 PUMP

1. Disconnect suction line (1) from No. 2 flight control pump (2). Cap open part (3) on pump. Use gloves (E186).
2. Attach pressure line (4) from test stand to suction line (1). Use fitting (5).

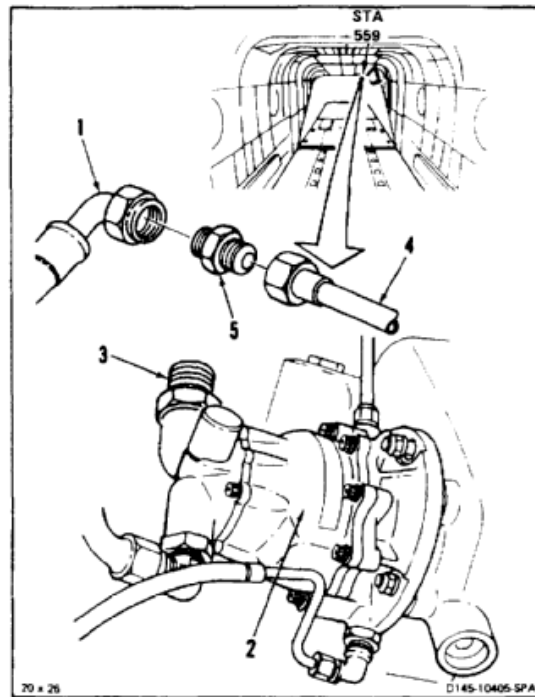

NO. 1 AND NO. 2 RESERVOIR/COOLERS

NOTE

Procedure is same at both No. 1 and No. 2 reservoir/cooler locations. Location of No. 2 reservoir/cooler shown above.

3. At both reservoir/cooler locations connect supply lines (6) to return lines (7) with test hoses (8) and fittings (9).

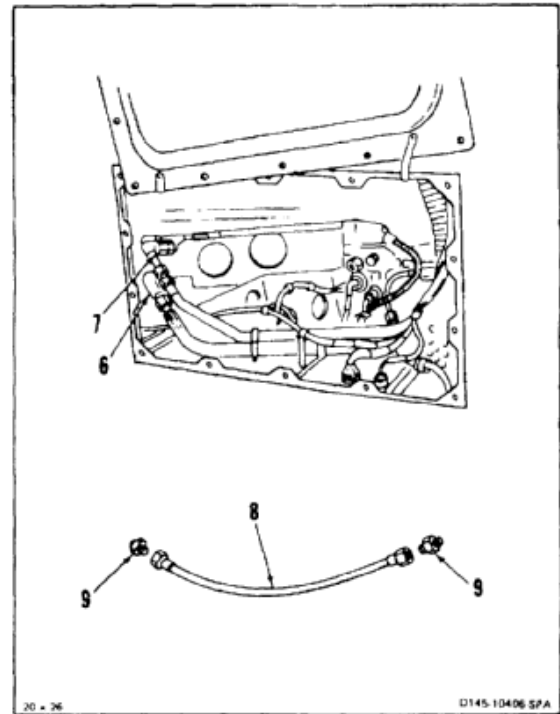

NO. 1 AND NO. 2 POWER CONTROL MODULES

NOTE

Procedure is same at both No. 1 and No. 2 power control module locations. Location of No. 2 power control module shown here.

4. At both power control module locations connect reservoir return lines (10) to system return lines (11) with test hoses (12) and fittings (13).

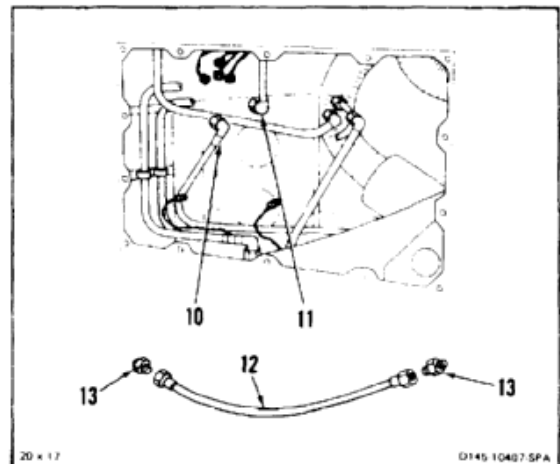

AFT SERVOCYLINDERS**NOTE**

Procedure is same at both pivoting and swiveling servocylinders. Pivoting servocylinder shown here.

5. Disconnect hoses (14 and 15) from tee fittings (16 and 17) on both pivoting and swiveling servocylinders (18). Cap open ports on servocylinders.
6. Connect hoses (14) to hoses (15) with test hoses (19) and fittings (20).

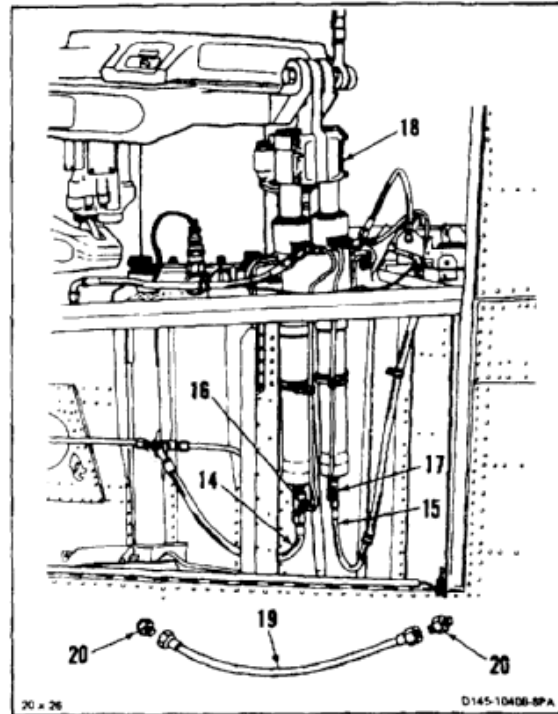
**NO. 1 AND NO. 2 POWER TRANSFER UNITS****NOTE**

Procedure is same at No. 1 and No. 2 power transfer units. No. 2 power transfer unit shown here.

7. Disconnect pump suction lines (21) from ports (22) of both power transfer units (23).
8. Loosen nuts (24) at other ends of suction lines (21).
9. Swing suction lines (21) away from ports (22). Cap ports (22) and plug lines (21). Tighten nuts (24).

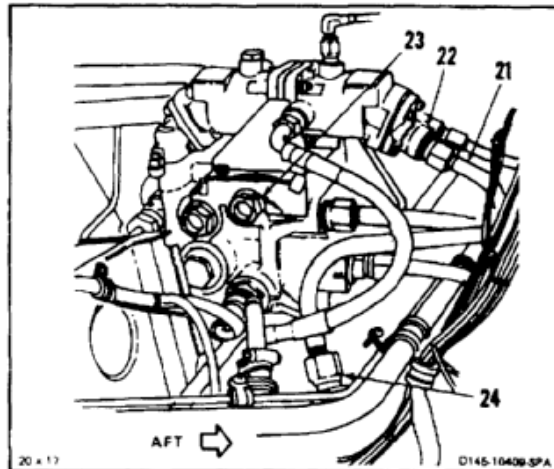

NO. 1 AND NO. 2 LOWER CONTROLS MODULES

10. Connect No. 2 module return line (25) to No. 1 module return line (26) with test hose (27) and fittings (28).

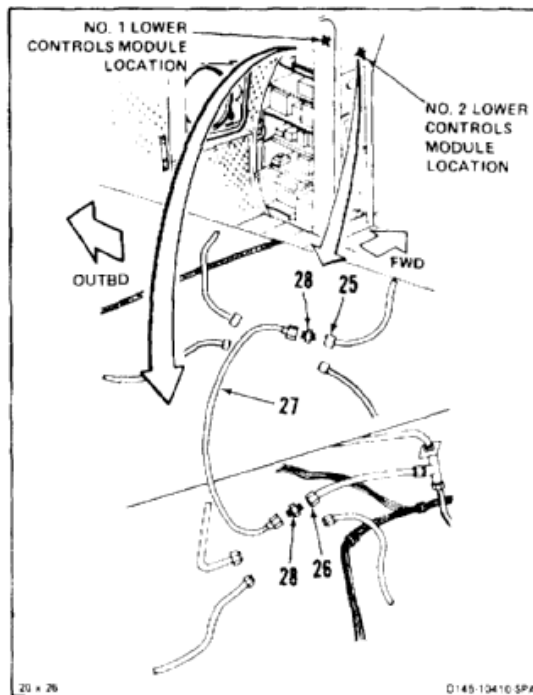

LOWER CONTROLS ACTUATORS

11. Connect No. 1 return line (29) to No. 2 return line (30) with test hose (31) and fittings (32).

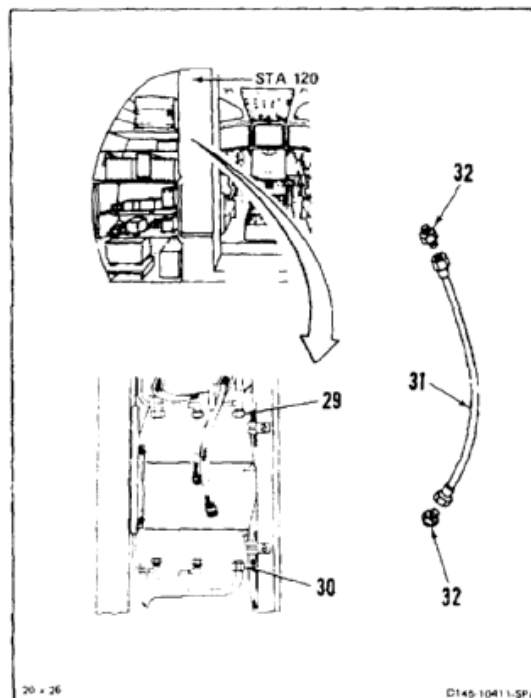

FORWARD SERVOCYLINDERS**NOTE**

Procedure is same at both pivoting and swiveling servocylinders. Pivoting servocylinder shown here.

12. Disconnect hoses (33 and 34) from tee fittings (35 and 36) on both pivoting and swiveling servocylinders (37).
13. Connect hoses (33) to (34) with test hoses (38) and fittings (39).

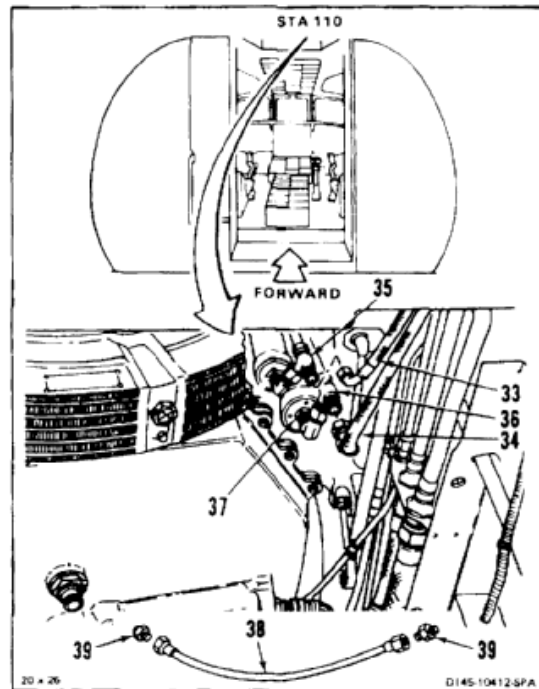
**NO. 1 PUMP**

14. Disconnect suction line (40) from No. 1 flight control pump (41). Cap open port (42) on pump.
15. Attach return line (43) from test stand to suction line (40) with fitting (44).

FOLLOW-ON MAINTENANCE:

Flush flight control system return lines (Task 7-13).

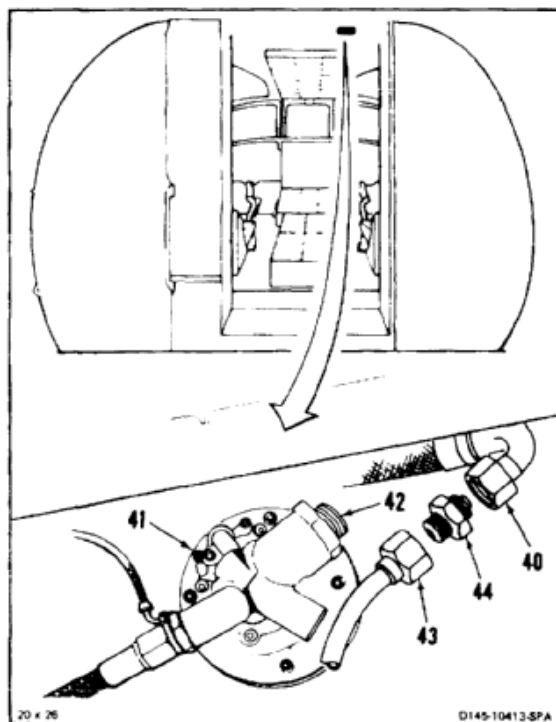

END OF TASK

7-80

7-13 FLUSHING FLIGHT CONTROL HYDRAULIC SYSTEM (RETURN LINES)

7-13

INITIAL SETUP**Applicable Configurations:**

All

Tools:

Hydraulics Repairer's Tool Kit, NSN
5180-00-323-4891
Container
Hydraulic Test Stand
Filter Assembly Kit ADHT6814-M9716M

Materials:

Hydraulic Fluid (E199)
Cloths (E120)
Gloves (E186)

Parts:

Hoses

Personnel Required:

Aircraft Pneudraulics Repairer
Inspector

Equipment Condition:

Flight Control System Prepared for Flushing (Task
7-12)

General Safety Instructions:**WARNING**

Hydraulic fluid (E199) is toxic. It can irritate skin and cause burns. Avoid inhaling. Use only with adequate ventilation. Avoid contact with skin, eyes, or clothing. In case of contact, immediately flush skin or eyes with water for at least **15 minutes**. Get medical attention for eyes.

WARNING

Hydraulic fluid ejected under pressure can cause injury to personnel. Hydraulic fluid sprayed into the air is a fire hazard.

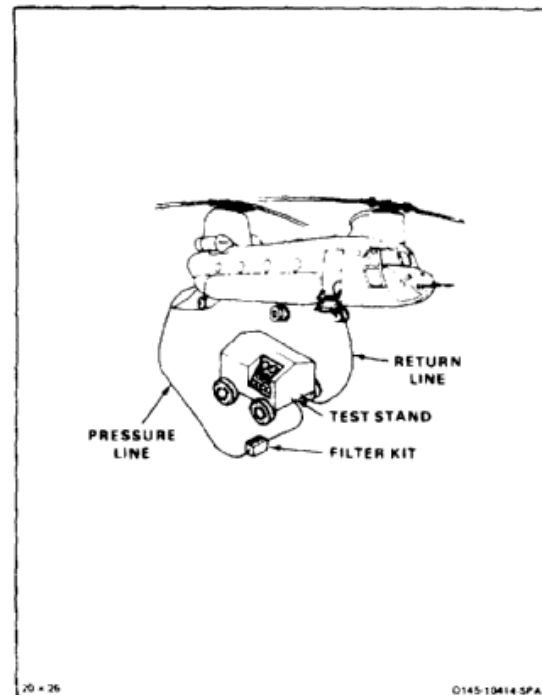

NOTE

Test stand filters must be cleaned before connecting test stand to helicopter.

Make sure filter assembly kit ADHT6814-M9716M is installed in test stand pressure hose.

To operate hydraulic test stand refer to applicable manual.

1. Open shutoff valve in test stand return lines.



Do not exceed **500 psi**. Otherwise, damage to components can occur.



Keep test stand bypass valve closed. Otherwise, contaminants could re-enter the system.

2. Set test stand to deliver **10 gpm at 500 psi** pressure.
3. Start test stand and slowly fill lines with hydraulic fluid. Check system for leaks.
4. Flush system for **5 minutes** to make sure system is filled.
5. Shut down test stand.

INSPECT

6. At No. 2 lower controls module location, disconnect bypass hose (1) from return line (2). Plug and cap both lines. Use gloves (E186).
7. At ILCA manifold location, disconnect bypass hose (3) from No. 1 return line (4). Plug and cap both lines.

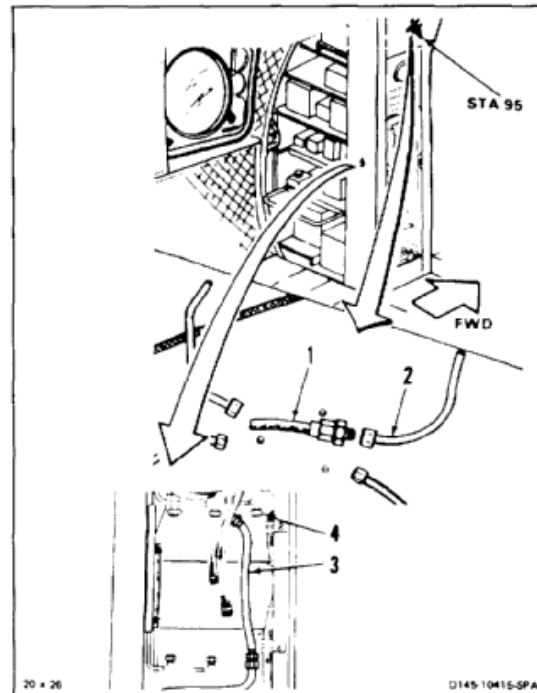
INSPECT

FLUSHING AFT UPPER CONTROLS RETURN SYSTEM**NOTE**

Procedure is same at both pivoting and swiveling servocylinders. Pivoting servocylinder shown here.

8. Remove bypass hoses (5) from return lines (6 and 7) at both forward servocylinders (8).



Do not exceed **500 psi**. Otherwise, damage to components can occur.



Keep test stand bypass valve closed. Otherwise, contaminants could re-enter the system.

9. Plug return lines (6 and 7).
10. Turn on test stand. Set stand to **10 gpm at 500 psi** and hold for **15 minutes**. Check for leaks.
11. Reduce pressure and shut down test stand.
12. Remove plugs from return lines (6 and 7).
13. Connect bypass hoses (5) to return lines (6 and 7).

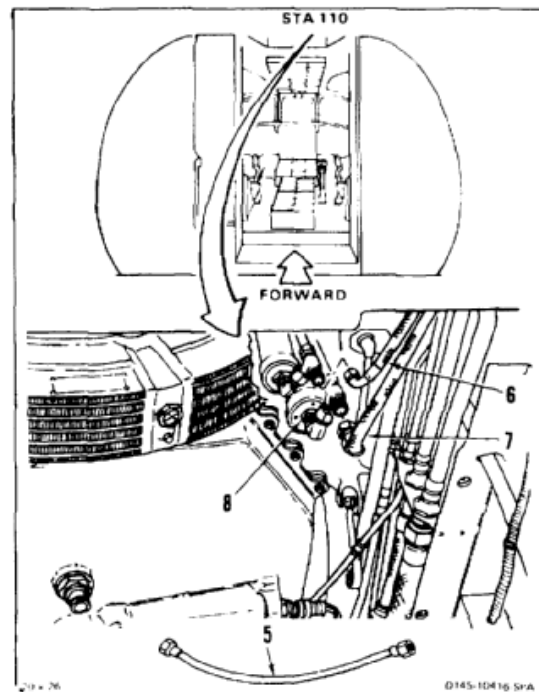
INSPECT

FLUSHING FORWARD UPPER CONTROLS RETURN SYSTEM**NOTE**

Procedure is same at both pivoting and swiveling servocylinders. Pivoting servocylinder only shown here.

14. Remove bypass hoses (9) from return lines (10 and 11) at both aft servocylinders (12).
15. Plug return lines (10 and 11).
16. Repeat steps 10 and 11.

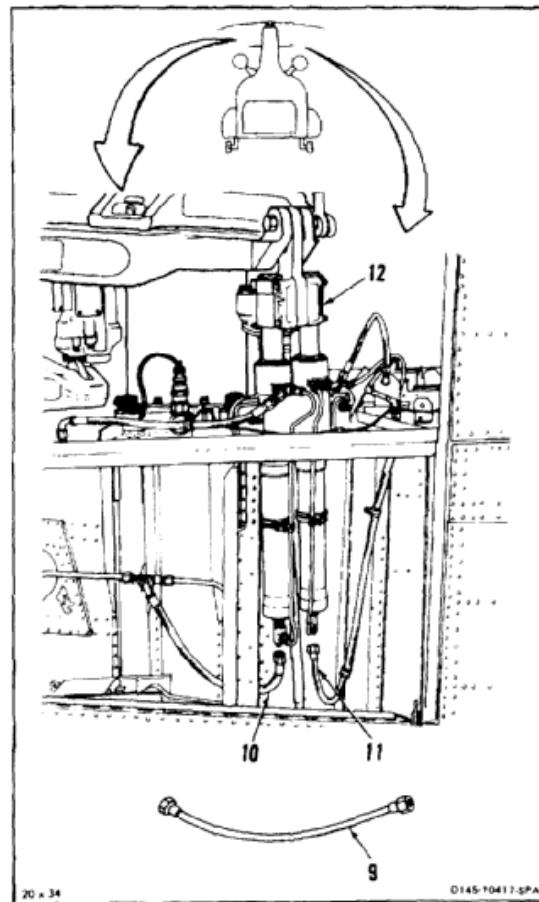
INSPECT**FLUSHING LOWER CONTROLS RETURN SYSTEM**

17. Repeat steps 8 and 9.
18. At ILCA manifold location remove plug from No. 1 return line (4). Remove cap from bypass hose (3).
19. Connect bypass hoses (3) to return line (4).
20. Repeat steps 10 and 11.
21. Remove bypass hose (3) from return line (4). Plug and cap both lines.

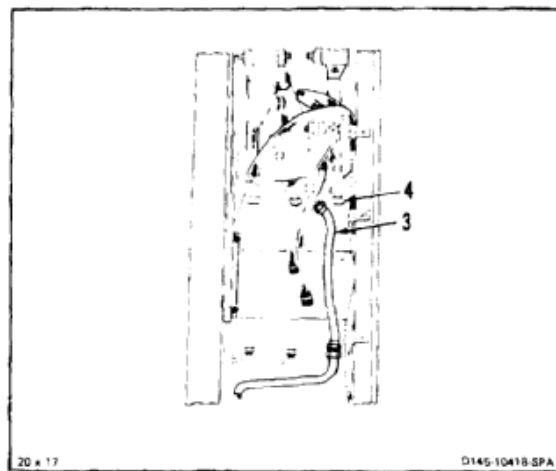
INSPECT

22. At No. 2 lower controls module location remove plug from return line (2). Remove cap from bypass hose (1).
23. Connect bypass hose (1) to return line (2).
24. Repeat steps 10 and 11.

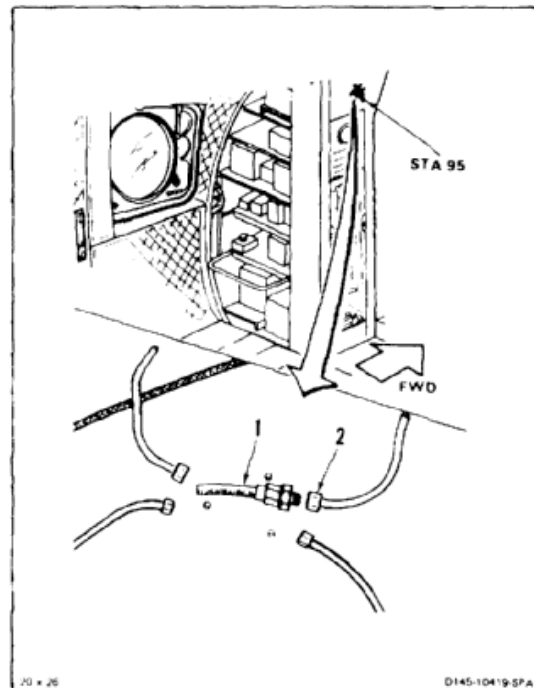
INSPECT**FOLLOW-ON MAINTENANCE:**

Prepare flight control hydraulic system (return lines) after flushing (Task 7-14).

END OF TASK

INITIAL SETUP

General Safety Instructions:

Applicable Configurations:

All

Tools:

- Hydraulic Repairer's Tool Kit, NSN 5180-00-323-4891
- Containers
- Hydraulic Test Stand
- Filter Assembly Kit ADHT6814-M9716M
- Workstand

Materials:

- Cloths (E120)
- Gloves (E186)

Personnel Required:

- Aircraft Pneudraulic Repairer
- Inspector

Equipment Condition:

Flushing Flight Control Hydraulic System (Return Lines) Completed (Task 7-13)

WARNING

Hydraulic fluid (E199) is toxic. It can irritate skin and cause burns. Avoid inhaling. Use only with adequate ventilation. Avoid contact with skin, eyes, or clothing. In case of contact, immediately flush skin or eyes with water for at least **15 minutes**. Get medical attention for eyes.

WARNING

Hydraulic fluid ejected under pressure can cause injury to personnel. Hydraulic fluid sprayed into the air is a fire hazard.

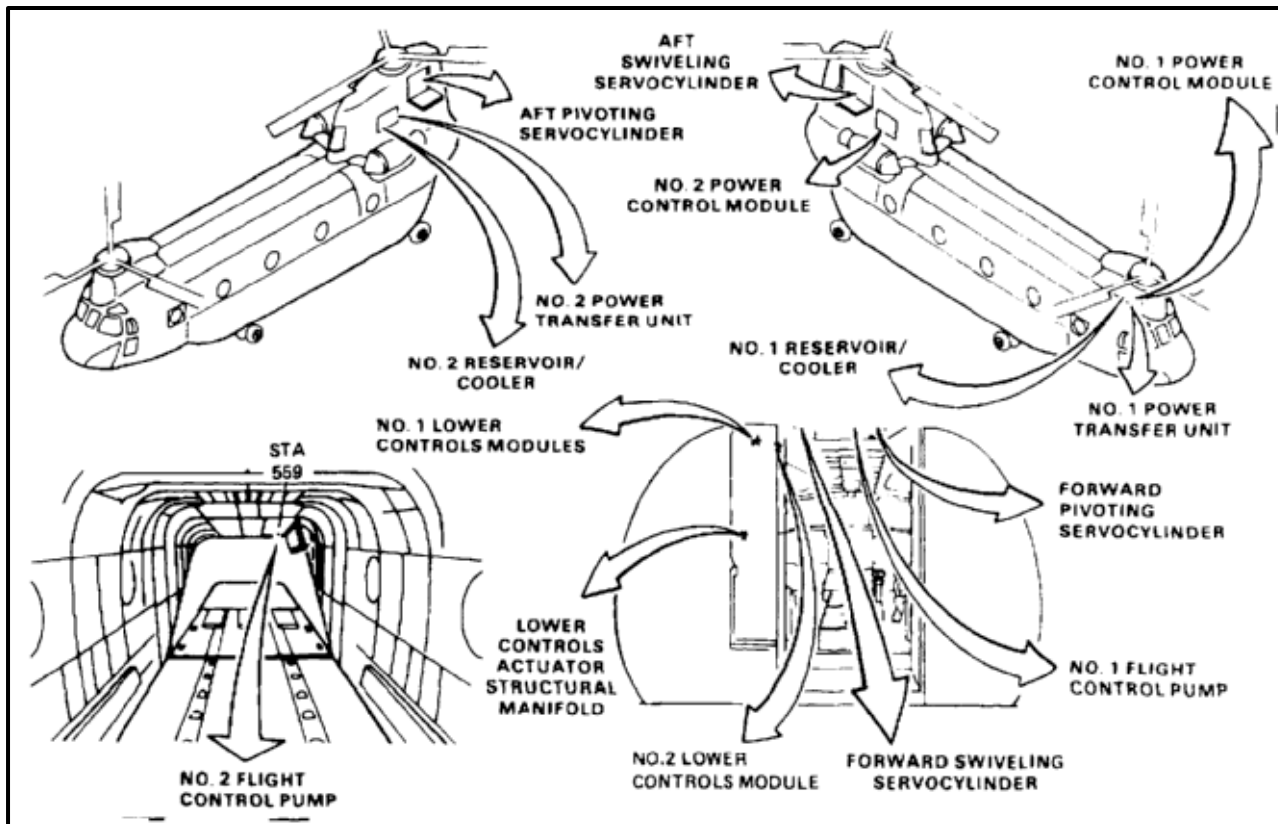

7-14 PREPARE FLIGHT CONTROL HYDRAULIC SYSTEM AFTER FLUSHING (RETURN LINES) (Continued)

7-14

NO. 1 PUMP

1. Remove test stand return line (1) and union (2) from No. 1 pump suction line (3). Use gloves (E186).
2. Remove cap from suction port (4) of No. 1 pump (5).
3. Connect line (3) to suction port (4).

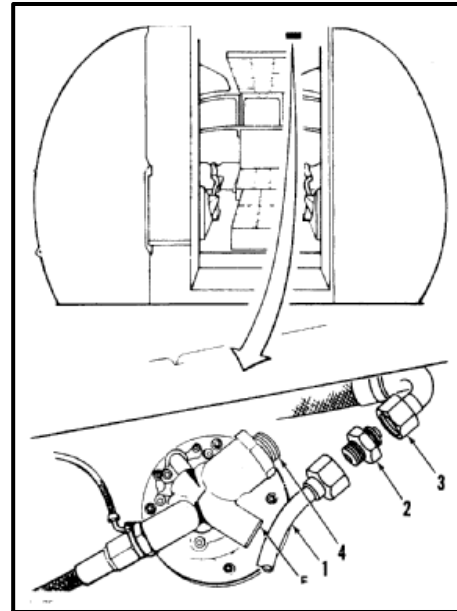
INSPECT**FORWARD SERVOCYLINDERS****NOTE**

Procedure is same at both pivoting and swiveling servocylinders. Pivoting servocylinder shown here.

4. Remove plugs from return hoses (6 and 7) at both forward servocylinders (8).
5. Remove four caps from tee fittings (9 and 10) on both servocylinders (8).
6. Connect return hoses (6) to tees (9) and return hoses (7) to tees (10) on both servocylinders (8).

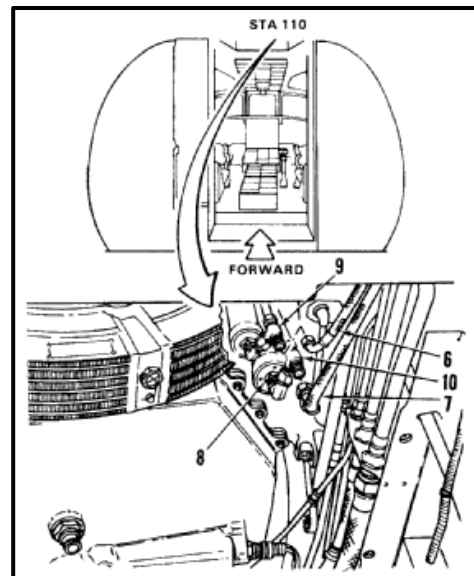
INSPECT

LOWER CONTROLS ACTUATORS

7. Remove bypass hose (11) and fittings (12) from No. 2 return lines (13).
8. Plug No. 1 return line (14) and No. 2 return line (13).

INSPECT

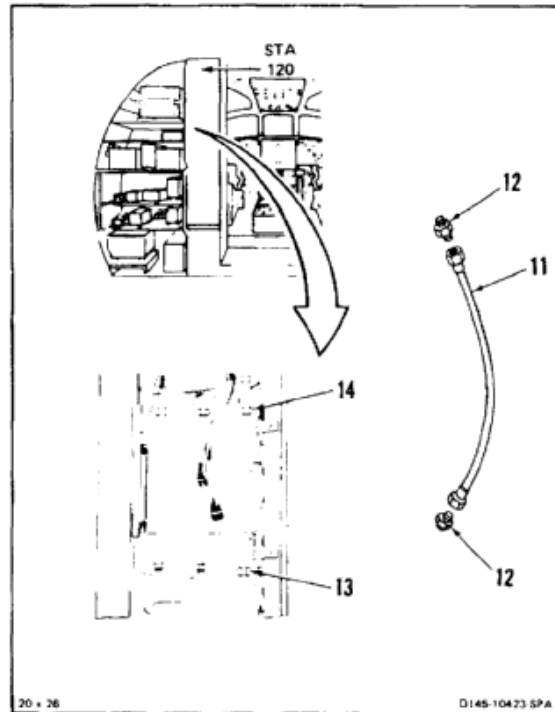

NO. 1 AND NO. 2 LOWER CONTROLS MODULES

9. Remove test hose (15) and fittings (16) from No. 1 module return line (17) and No. 2 module return line (18). Plug open lines.

INSPECT

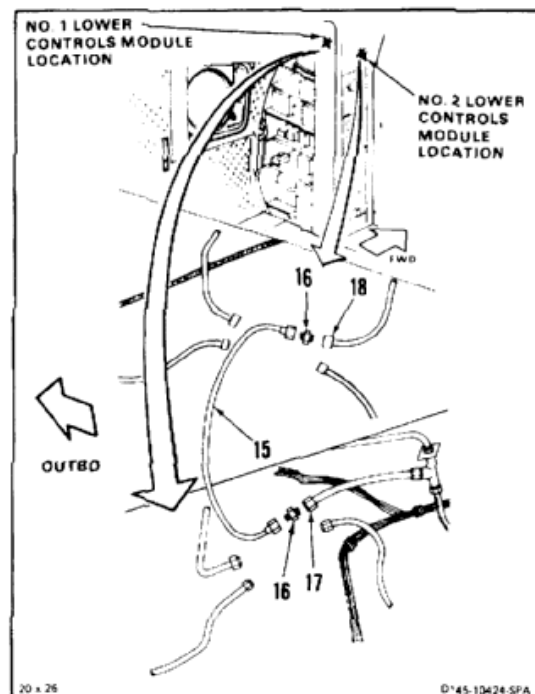

NO. 1 AND NO. 2 POWER TRANSFER UNITS**NOTE**

Procedure is same at No. 1 and No. 2 power transfer units. No. 2 power transfer units shown here.

10. Remove plugs from suction lines (19) and caps from suction parts (20) of power transfer units (21).
11. Loosen units (22). Connect suction lines (19) to parts (20). Tighten nuts (22).

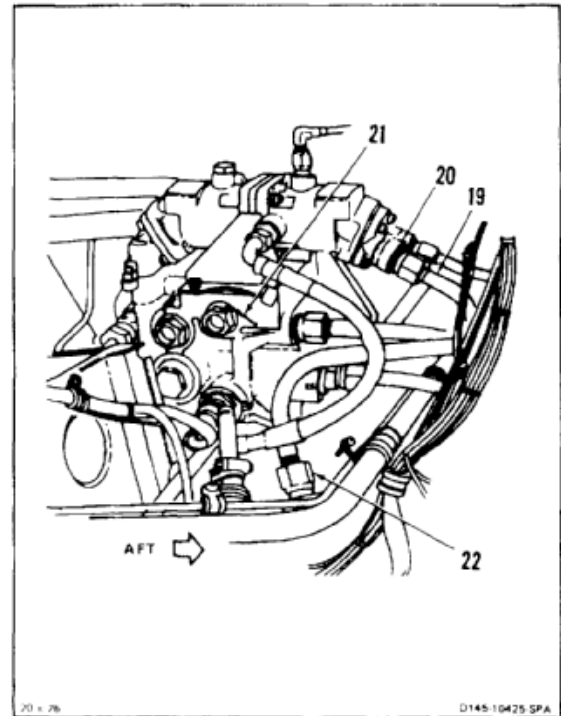
INSPECT**AFT SERVOCYLINDERS****NOTE**

Procedure is same at both pivoting and swiveling servocylinders. Pivoting servocylinder shown here.

12. Remove plugs from return hoses (23 and 24) at both aft servocylinders (25).
13. Remove four caps from tee fittings (26 and 27) on both servocylinders (25).
14. Connect return hoses (23) to tees (26) and return hoses (24) to tees (27) on both servocylinders (25).

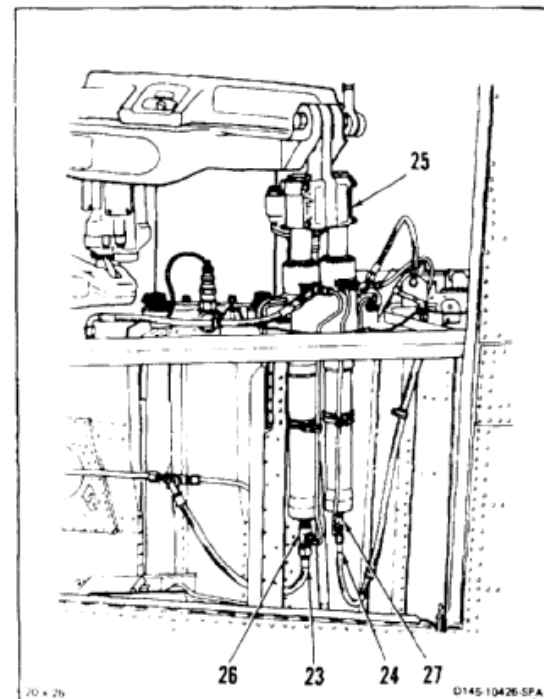
INSPECT

NO. 1 AND NO. 2 POWER CONTROL MODULES

NOTE

Procedure is same at both No. 1 and No. 2 power control modules locations. Locations of No. 2 power control module shown here.

- 15. At both control module locations, remove bypass hoses (28) and fittings (29) from reservoir return lines (30) and system return lines (31). Plug open lines.

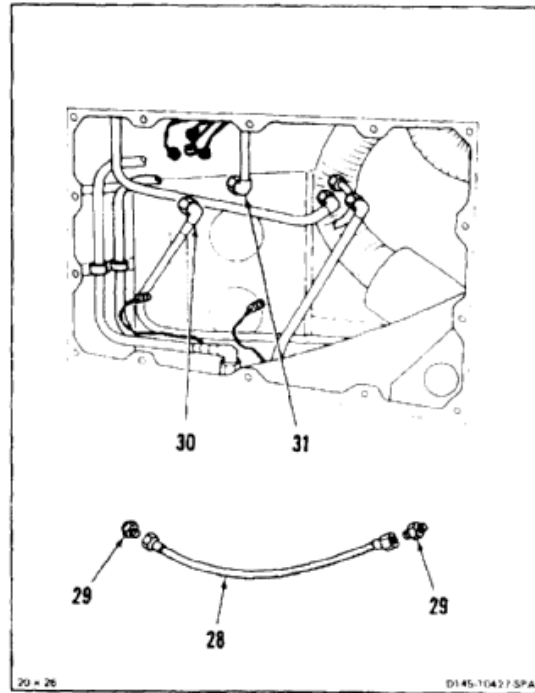

NO. 1 AND NO. 2 RESERVOIR/COOLERS

NOTE

Procedure is same at No. 1 and No. 2 reservoir/cooler locations. Location of No. 2 reservoir/cooler shown here.

- 16. At both reservoir/cooler locations remove bypass hose (32) and fittings (33) from supply lines (34) and return lines (35). Plug open lines.

INSPECT

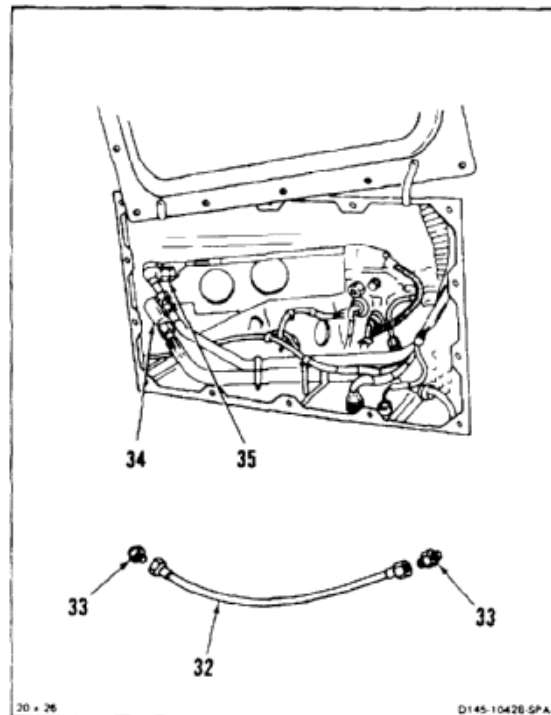

7-14 PREPARE FLIGHT CONTROL HYDRAULIC SYSTEM AFTER FLUSHING (RETURN LINES) (Continued)

7-14

NO. 2 PUMP

17. Disconnect test stand return line (36) and fitting (37) from pump suction line (38).
18. Remove cap from suction port (39) of No. 2 flight control pump (40).
19. Connect suction line (38) to suction port (39).
20. Remove all test hoses and fittings from helicopter.
21. Remove filter assembly kit from test stand pressure hose.

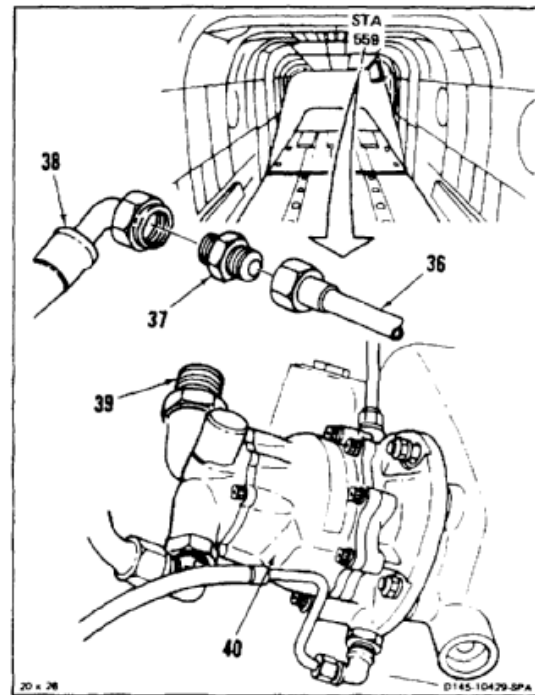
INSPECT**FOLLOW-ON MAINTENANCE:**

- Install No. 1 and No. 2 flight control reservoir coolers (Task 7-117).
- Install No. 1 and No. 2 flight control lower controls modules (Task 7-79).
- Install lower controls actuator structural manifold (Task 7-104).
- Install integrated lower controls actuators (ILCA) (Task 7-102).
- Install No. 1 power control module (Task 7-30).
- Install No. 2 power control module (Task 7-32).
- Bleed flight control hydraulic system (Task 7-16).
- Close left transmission baffle (Task 2-2).
- Close forward work platforms (Task 2-2).
- Close aft work platforms (Task 2-2).
- Close pylon access doors (Task 2-2).
- Install forward transmission drip pan (Task 2-3).
- Perform operational check of flight control hydraulic system (TM 55-1 520-240-T).

END OF TASK

INITIAL SETUP

Applicable Configurations:

All

Tools:

- Hydraulic Repairer's Tool Kit, NSN 5780-0-323-4891 Container
- Hydraulic Test Stand
- Filter Assembly Kit ADHT6814-M9716M

Materials:

- Hydraulic Fluid (E199)
- Cloths (E120)
- Gloves (E186)

Parts:

- Test Hoses
- Fittings

Personnel Required:

- Aircraft Pneudraulics Repairer
- Inspector

Equipment Condition:

- Battery Disconnected (Task 1-39)
- Electrical Power Off
- Hydraulic Power Off
- No. 1 Power Control Module Removed (Task 7-29)
- No. 2 Power Control Module Removed (Task 7-31)
- Pylon Access Door Open (Task 2-2)
- Forward Work Platforms Open (Task 2-2)
- Hydraulic Connection Access Panel Open (Task 2-2)

General Safety Instructions:

WARNING

Hydraulic fluid (E199) is toxic. It can irritate skin and cause burns. Avoid inhaling. Use only with adequate ventilation. Avoid contact with skin, eyes, or clothing. In case of contact, immediately flush skin or eyes with water for at least **15 minutes**. Get medical attention for eyes.

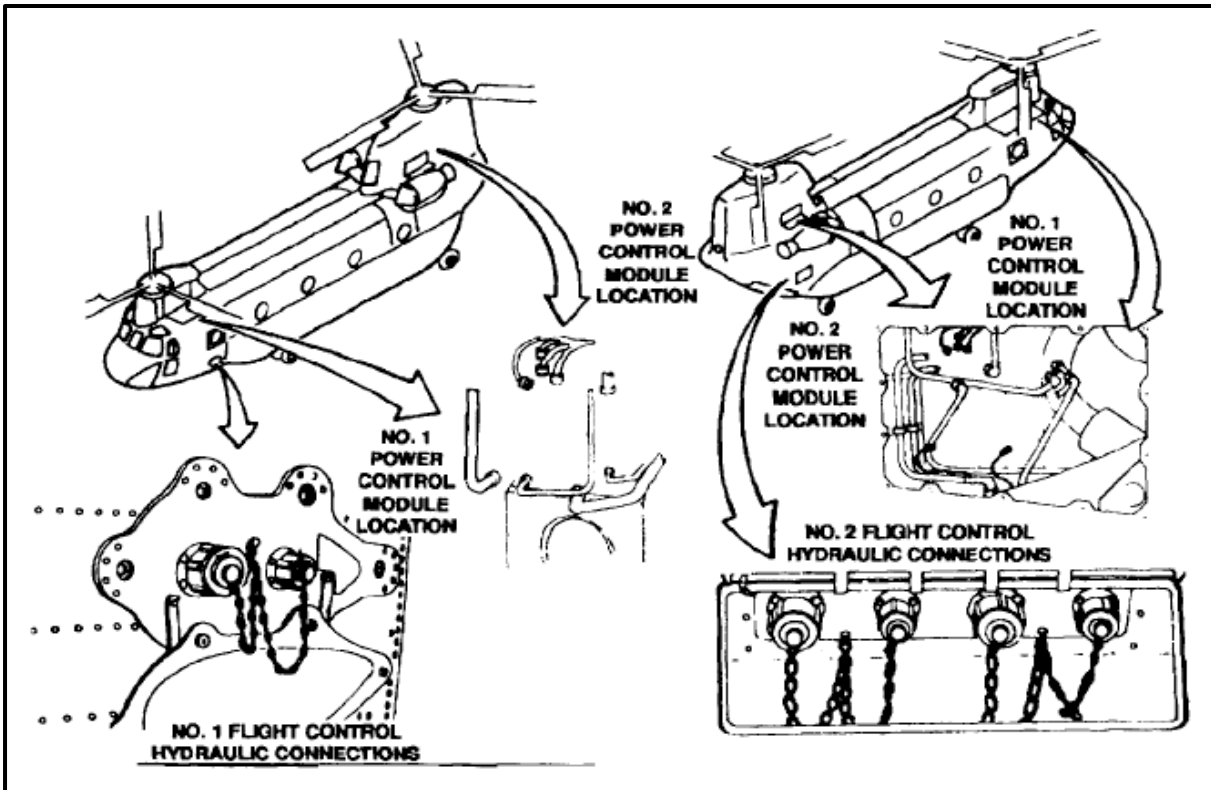

WARNING

Hydraulic fluid ejected under pressure can cause injury to personnel. Hydraulic fluid sprayed into the air is a fire hazard.

FLUSHING NO. 1 SYSTEM

1. Connect external pressure line (1) to external return line (2) with bypass hose (3) and fittings (4). Use gloves (E186).

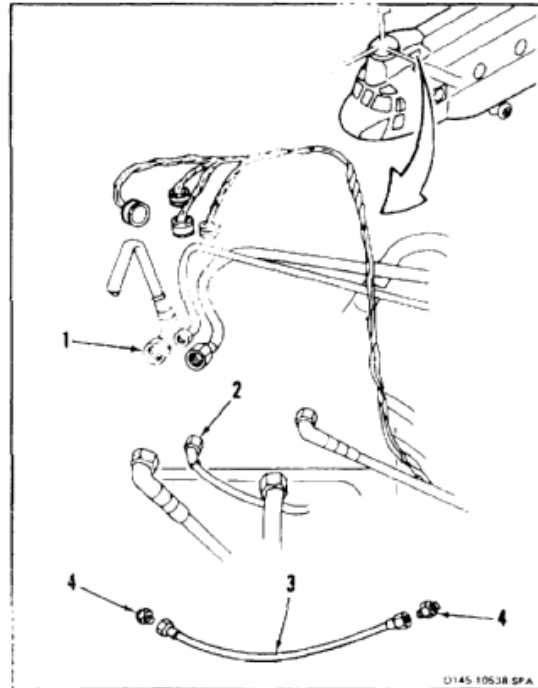

2. Release six fasteners (5) and remove cover (6).
3. Remove dust covers (7) from PRESSURE connection (8) and dust cover (9) from SUCTION connection (10).

NOTE

Test stand filters must be cleaned before connecting test stand to helicopter.

Make sure filter assembly kit ADHT6814-M9716M is installed in test stand pressure hose.

To operate hydraulic test stand, refer to applicable manual.

4. Connect test stand pressure line (11) to PRESSURE connection (8) and test stand return line (12) to SUCTION connection (10).
5. Open shutoff valve in test stand return line.



Keep test stand bypass valve closed. Otherwise, contaminants could re-enter the system.

6. Set test stand to deliver **10 gpm** at **500 psi** pressure.
7. Start test stand and slowly fill lines with hydraulic fluid. Check system for leaks.
8. Increase test stand pressure to **700 psi** and hold for **15 minutes**.
9. Reduce pressure and shut down test stand.
10. Disconnect test stand pressure line (11) from PRESSURE connection (8) and test stand return line (12) from SUCTION connection (10).
11. Replace dust cover (7) on PRESSURE connection (8) and dust cover (9) on SUCTION connection (10).
12. Install cover (6) and tighten six fasteners (5).

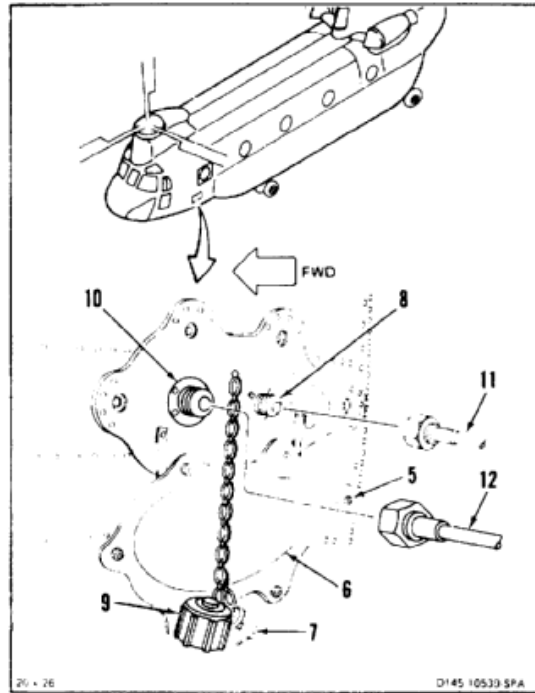
INSPECT

7-15 FLUSHING EXTERNAL POWER SUPPLY LINES — FLIGHT CONTROL HYDRAULIC SYSTEM (Continued)

13. Remove bypass hose (3) and fittings (4) from pressure line (1) and return line (2). Plug open lines.

INSPECT

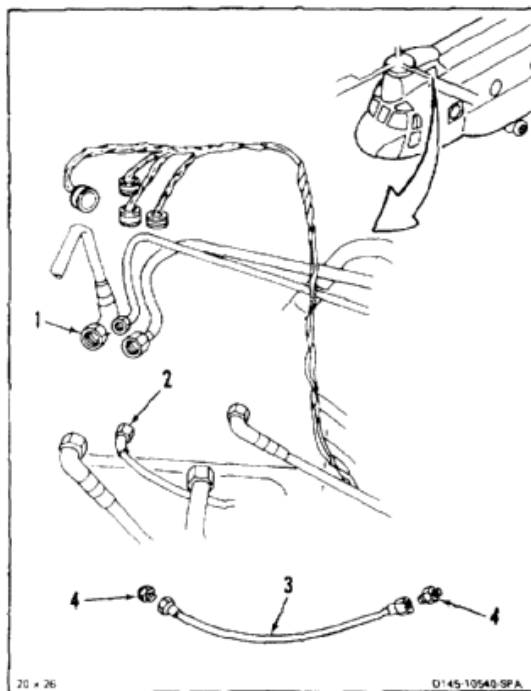

FLUSHING NO. 2 SYSTEM

14. Connect external pressure line (13) to external return line (14) with bypass hose (3) and fittings (4).

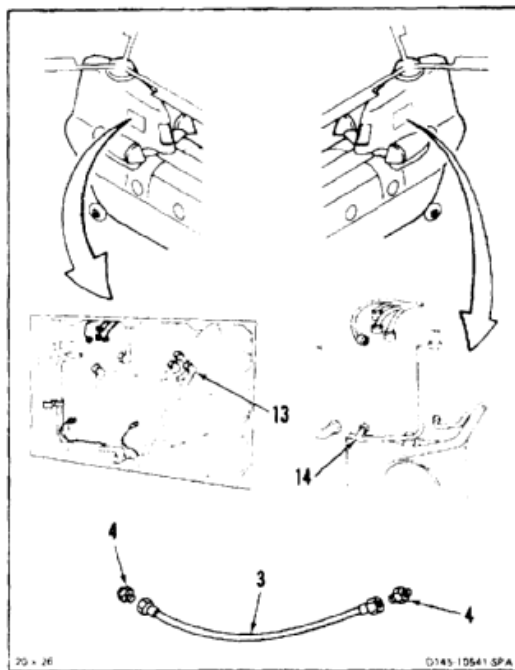

15. Remove dust cover (15) from PRESSURE connection (16) and dust cover (17) from SUCTION connection (18).
16. Connect test stand pressure line (11) to PRESSURE connection (16) and test stand return line (12) to SUCTION connection (18).
17. Repeat steps 5 thru 9.
18. Disconnect test stand pressure line (11) from PRESSURE connection (16) and test stand return line (12) from SUCTION connection (18).
19. Replace dust cover (15) on PRESSURE connection (16) and dust cover (17) on SUCTION connection (18).

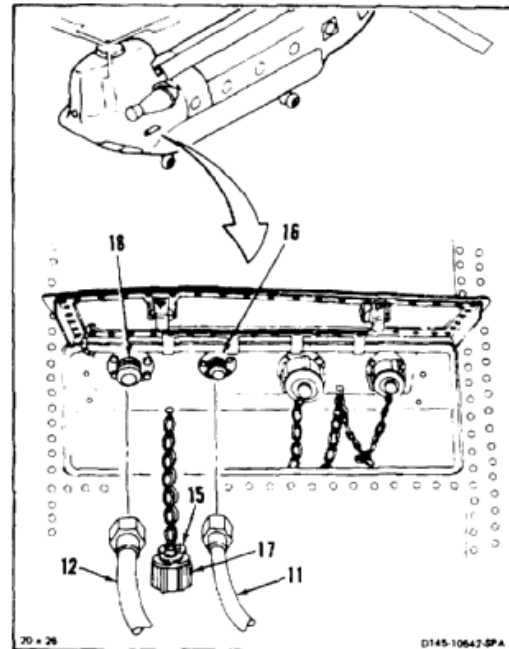
INSPECT

20. Remove bypass hose (3) and fittings (4) from pressure line (13) and return line (14). Plug open lines.

INSPECT

21. Remove all test hoses and fittings from helicopter.
22. Remove filter assembly kit from test stand pressure hose.

FOLLOW-ON MAINTENANCE:

Close hydraulic connection access panel (Task 2-2).
 Install No. 1 power control module (Task 7-30).
 Install No. 2 power control module (Task 7-32).
 Bleed flight control hydraulic systems (Task 7-16).
 Close pylon access doors (Task 2-2).
 Close forward work platforms (Task 2-2).
 Perform operational check of flight control hydraulic systems (TM 55-1520-240-T).

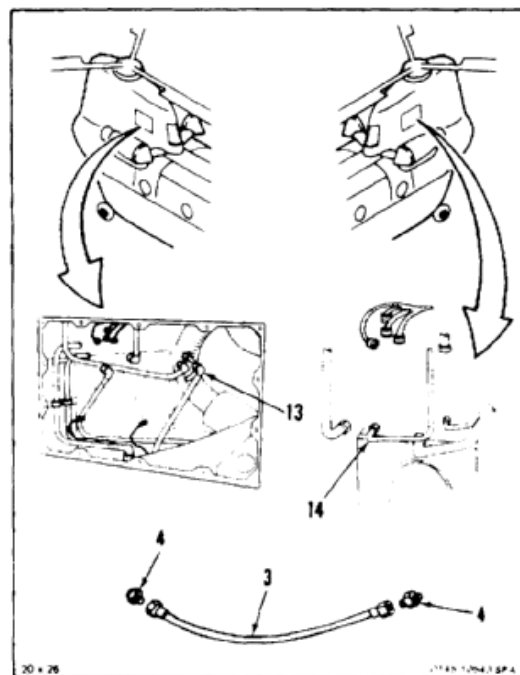

END OF TASK

INITIAL SETUP

Applicable Configurations:

All

Tools:

- Hydraulic Repairer's Tool Kit, NSN 5180-00-323-4891
- Containers
- Hydraulic Test Stand
- Filters Assembly Kit ADHT6814-M9716M
- Workstand

Materials:

- Hydraulic Fluid (E199)
- Cloths (E120)
- Lockwire (E231)
- Gloves (E186)

Personnel Required:

- Medium Helicopter Repairer
- Aircraft Pneudraulics Repairer
- Inspector

References:

- Task 1-61
- Task 1-63
- Task 7-22
- Task 7-23
- Task 7-27
- Task 7-28

Equipment Condition:

- Flight Control System Accumulators Serviced (Task 1-63)
- Flight Control Hydraulic System Reservoirs Serviced (Tasks 1-60, 1-61, 1-62)
- Flight Control Hydraulic Systems Flushed (Tasks 7-10, 7-11, 7-12, 7-13, 7-14)
- Utility Hydraulic System Filled and Bled (Task 7-335)
- Battery Connected (Task 1-39)
- Electrical Power On
- Hydraulic Power Off
- Right Forward Work Platform Open (Task 2-2)
- Left Pylon Access Door Open (Task 2-2)
- Forward Transmission Drip Pan Removed (Task 2-3)
- Left Transmission Baffle Open (Task 2-2)
- Controls Closet Acoustic Blanket Removed (Task 2-107)
- Hydraulic Connection Access Panel Open (Task 2-2)
- Tiedown Line Attached to Forward Blades (Task 1-26)

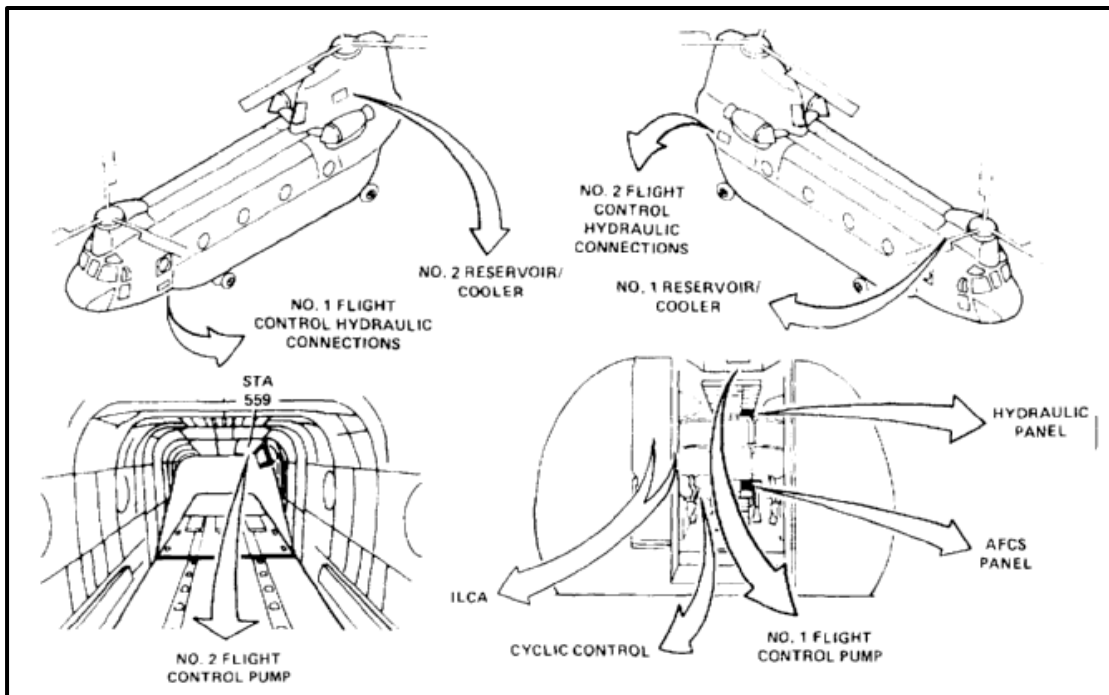

General Safety Instructions:**WARNING**

Hydraulic fluid (E199) is toxic. It can irritate skin and cause burns. Avoid inhaling. Use only with adequate ventilation. Avoid contact with skin, eyes, or clothing. In case of contact, immediately flush skin or eyes with water for at least **15 minutes**. Get medical attention for eyes.

WARNING

Hydraulic fluid ejected under pressure can cause injury to personnel. Hydraulic fluid sprayed into the air is a fire hazard.

NOTE

Test stand filters must be cleaned before connecting test stand to helicopters.

Make sure filter assembly kit ADHT6814-M9716M is installed in test stand pressure line.

To operate hydraulic test stand refer to applicable manual.

NO. 1 FLIGHT CONTROL HYDRAULIC SYSTEM

1. Release six fasteners (1) and remove cover (2).
2. Remove dust cover (3) from PRESSURE connection (4) and dust cover (5) from SUCTION connection (6).
3. Connect test stand pressure line (7) to PRESSURE connection (4) and test stand return lines (8) to SUCTION connection (6). Open shutoff valve in test stand return line. Use gloves (E186).
4. Start test stand and set stand to **6 gpm** flow. Allow lines to fill. Slowly increase stand pressure to **3000 psi**.

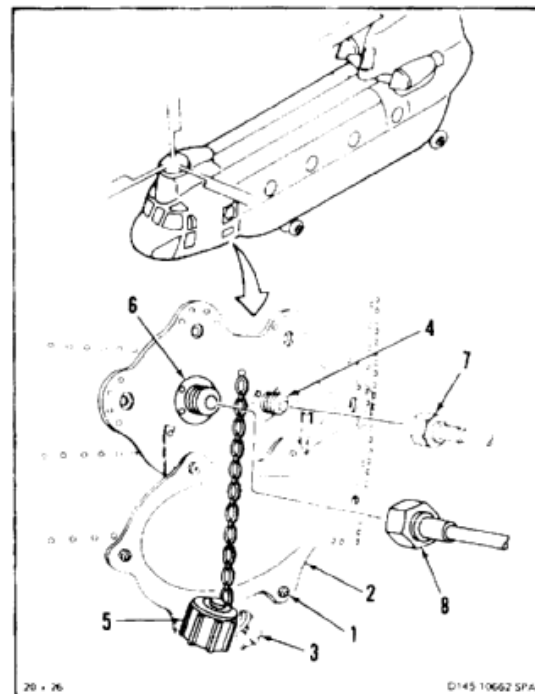

5. In cockpit, set FLT CONTR switch (9) on HYDRAULIC panel (10) to No. 1 ON.
6. Slowly cycle cyclic control (11) for **5 minutes**.

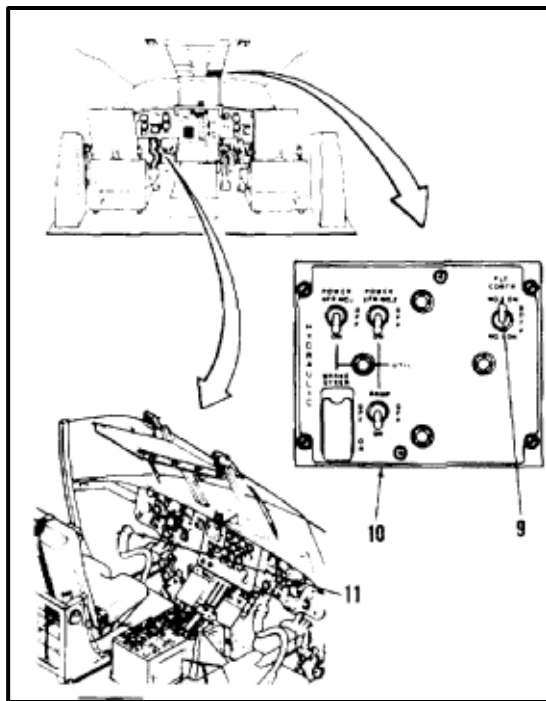

7. In cockpit, cycle SYSTEM SEL switch (12) on AFCS panel (13) from OFF to 1 to OFF five times.
8. Set SYSTEM SEL switch (12) to 1.

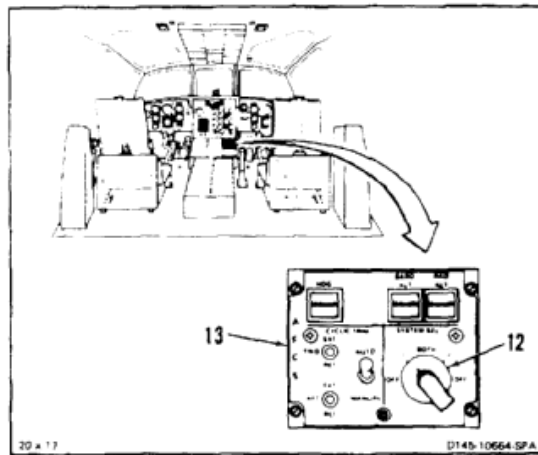

9. In cabin, remove lockwire from bleed plug (14) on No. 1 extensible link assembly (15) of each integrated lower controls actuator (ILCA) (16).
10. Loosen bleed plug (14) on each ILCA (16). Use container and cloths (E120). When fluid flow from each bleed plug is air-free, tighten plug. Install lockwire (E231). Use gloves (E186).

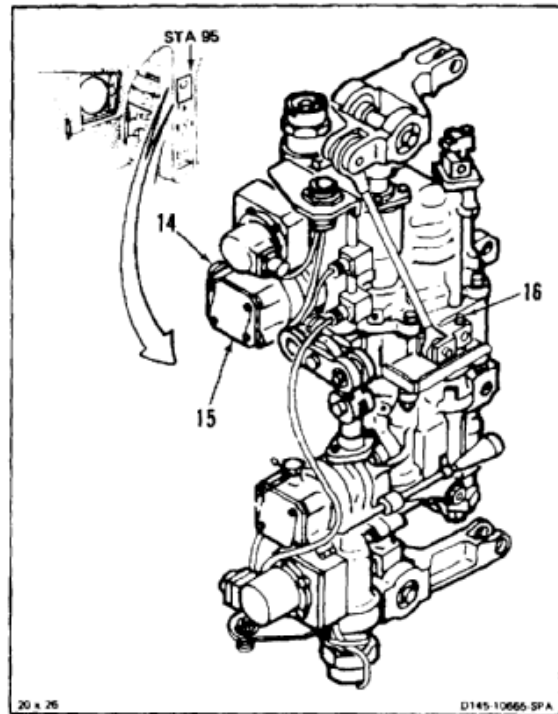

11. At No. 1 reservoir/cooler (17) open bleed valve (18) until all air is bled. Close bleed valve.
12. Service No. 1 reservoir (17) (Task 1-61 or 1-63).

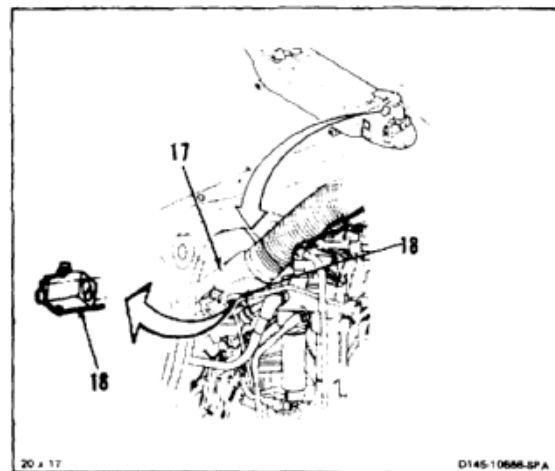

13. Disconnect drain tube (19) from case drain port (20) of No. 1 pump (21).
14. Make sure case of No. 1 pump (21) is full of hydraulic fluid (E199). Fill case with fluid through case drain port (20) as required.
15. Have helper rotate rotary wings at least **10 complete turns** by pulling blades around in normal direction. Use blade tiedown lines on forward rotor blades. Turn rotors until hydraulic fluid flows from case drain port (20). Use containers and cloths (E120).
16. Connect case drain line (19) to case drain port (20).

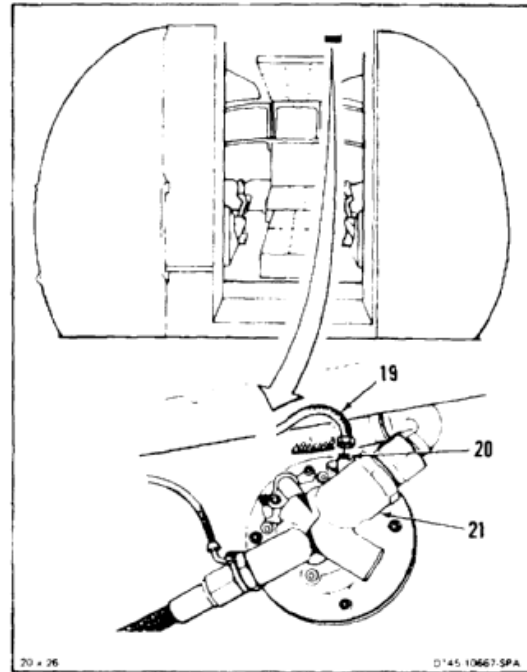

17. Disconnect test stand pressure line (7) from PRESSURE connection (4) and test stand return line (8) from SUCTION connection (6).
18. Replace dust covers (3) on PRESSURE connection (4) and dust cover (5) on SUCTION connection (6).
19. Install cover (2) and tighten six fasteners (1).
20. Service No. 1 reservoir (Task 1-61 or 1-63).

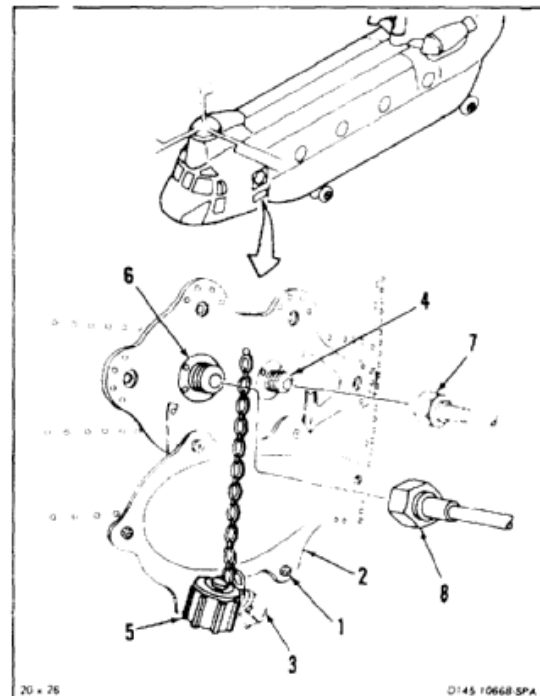
INSPECT

NO. 2 FLIGHT CONTROL HYDRAULIC SYSTEM

21. Remove dust cover (22) from PRESSURE connection (23) and dust cover (24) from SUCTION connection (25).
22. Connect test stand pressure line (26) to PRESSURE connection (23) and test stand return line (27) to SUCTION connection (25). Open shutoff valve in test stand return line.
23. Start test stand and set stand to **6 gpm** flow. Allow lines to fill. Slowly increase stand pressure to **3000 psi**.

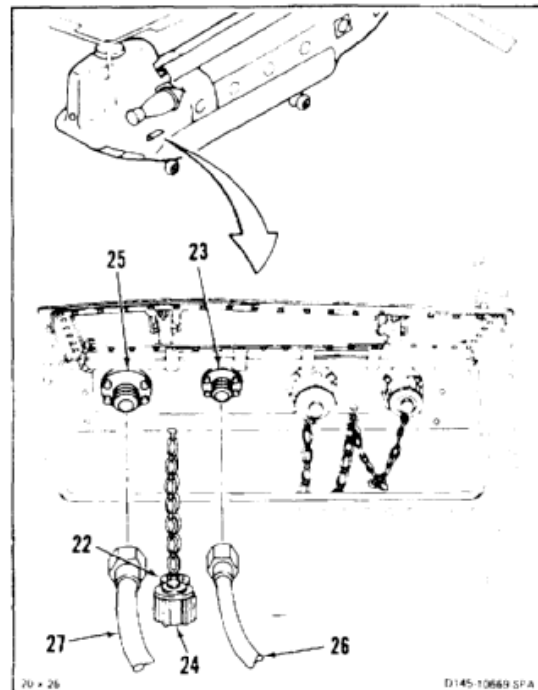

24. In cockpit, set FLT CONTR switch (9) on HYDRAULIC panel (10) to No. 2 ON.
25. Slowly cycle cyclic control (11) for **5 minutes**.

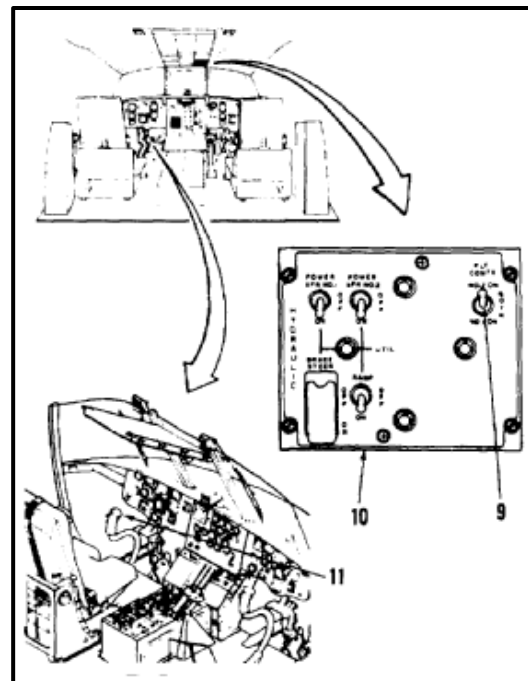

- 26. In cockpit, cycle SYSTEM SEL switch (12) on AFCS panel (13) from OFF to 2 to OFF five times.
- 27. Set SYSTEM SEL switch (12) to 2.

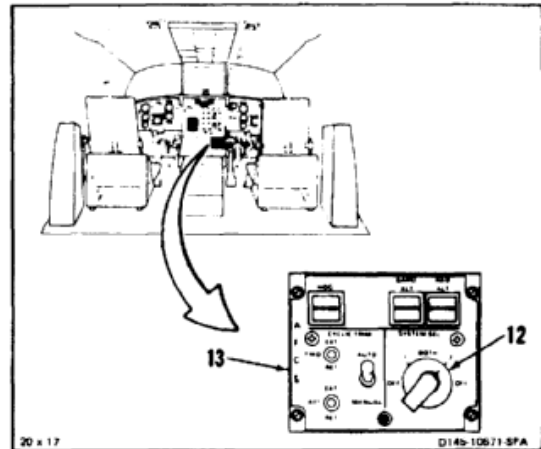

- 28. In cabin, remove lockwire from bleed plug (28) on No. 2 extensible link (29) of each integrated lower controls actuator (ILCA) (16).
- 29. Loosen bleed plug (28) on each ILCA (16). Use container and cloths (E120). When fluid flow from each bleed plug is airfree tighten plug. Install lockwire (E231).

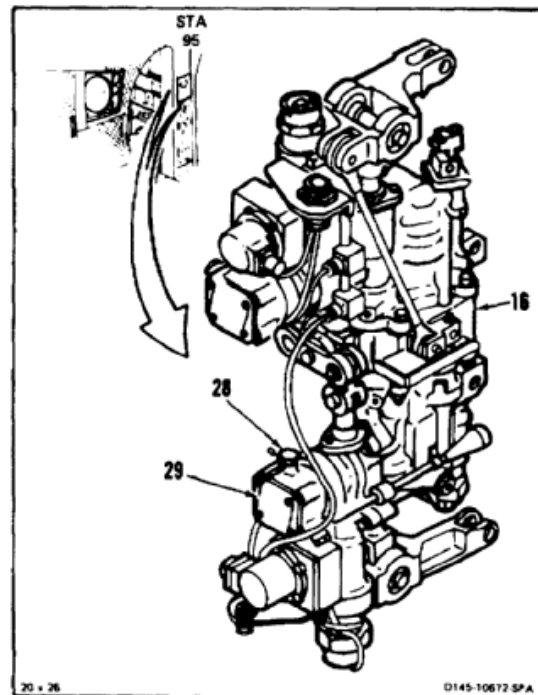

30. At No. 2 reservoir/cooler (30) open bleed valve (31) until all air is bled. Cycle cyclic control. Close bleed valve.
31. Shut down test stand. Close shutoff valve in test stand return line.
32. Service No. 2 reservoir (30) (Task 1-61 or 1-63).

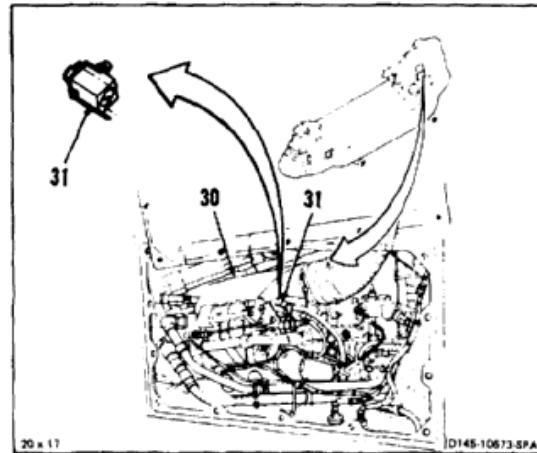

33. Disconnect case drain line (32) from case drain port (33) of No. 2 pump (34).
34. Make sure case of No. 2 pump is full of hydraulic fluid (E199). Fill case with fluid through drain port (33) as required.
35. Have helper rotate rotary wings at least **10 complete turns** by pulling blades around in normal direction. Use blade tie down lines on forward rotor blades. Turn rotors until hydraulic fluid flows from case drain port (33). Use container and cloths (E120).
36. Connect case drain line (32) to case drain port (33).

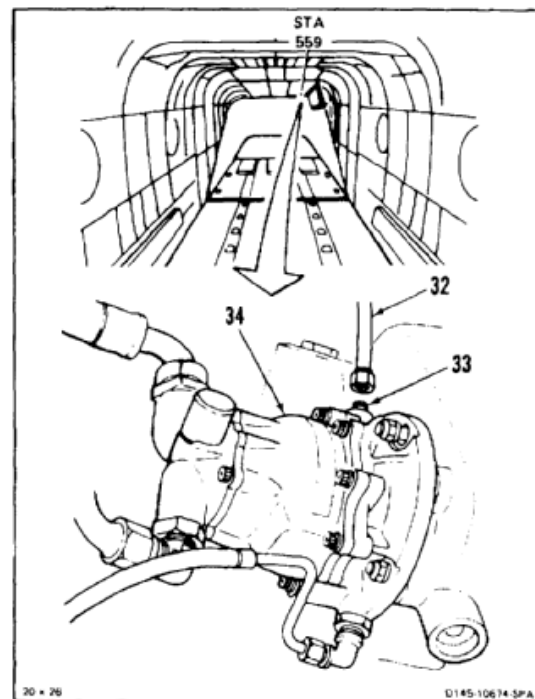

37. Disconnect test stand pressure line (26) from PRESSURE connection (23) and test stand return line (27) from SUCTION connection (25).
38. Replace dust cover (22) on PRESSURE connection (23) and dust cover (24) on RETURN connection (25).

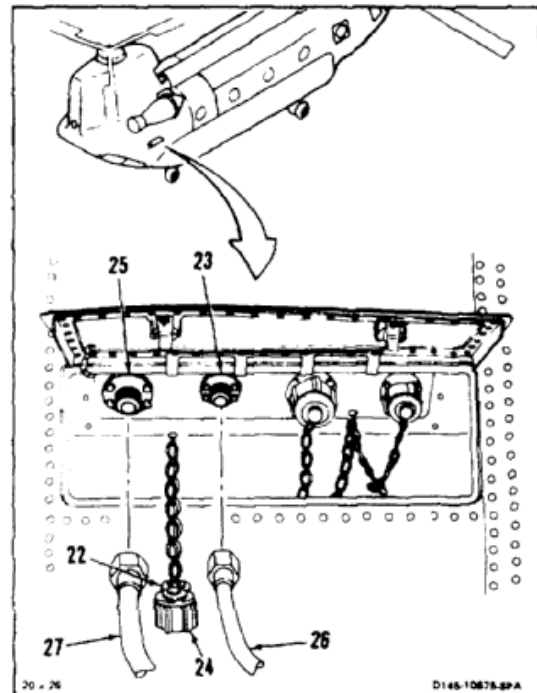
INSPECT**FOLLOW-ON MAINTENANCE:**

- Perform operational check of flight control hydraulic systems (TM 55-1520-240-T).
- Electrical power off.
- Close right forward work platform (Task 2-2).
- Close left pylon access door (Task 2-2).
- Install forward transmission drip pan (Task 2-3).
- Close left transmission baffle (Task 2-2).
- Install controls closet acoustic blanket (Task 2-108).
- Install controls closet panel (Task 2-2).
- Close hydraulic connection access panel (Task 2-2).

END OF TASK

INITIAL SETUP

Applicable Configurations:

All

Tools:

Hydraulic Repairer's Tool Kit, NSN 5180-00-323-4891
 Container, 55 Gallon
 Hydraulic Test Stand (2) (If Available) or AGPU Test
 Stand
 Filter Assembly Kit ADHT6814-M9716M (2)
 Hoses
 Workstand
 Electrical Power Supply
 Blade Tiedown Lines (3)
 Container, 2 Quart (2)
 Container, 2 Gallon (2)

Materials:

Cloths (E120)
 Gloves (E186)

Parts:

Packings
 Filters

References:

Task 1-24
 Task 1-26
 Task 1-59
 Task 1-61
 Task 1-60
 Task 2-2
 Task 2-3
 Task 2-193
 Task 2-208
 TM 55-1730-229-12
 TM 55-1520-240-T

Personnel Required:

Aircraft Pneudraulics Repairer (3)
 Aircraft Electrician
 Inspector

Equipment Condition:

Battery Connected (Task 1-39)
 External Electrical Power On (Task 1-37)
 Hydraulic Power Off
 External Hydraulic Power Connected (Task 1-38)

General Safety Instructions:**WARNING**

Hydraulic fluid (E199) is toxic. It can irritate skin and cause burns. Avoid inhaling. Use only with adequate ventilation. Avoid contact with skin, eyes, or clothing. In case of contact, immediately flush skin or eyes with water for at least **15 minutes**. Get medical attention for eyes.

Hydraulic fluid ejected under pressure can cause injury to personnel. Hydraulic fluid sprayed into the air is a fire hazard.

Keep head, hands and other body parts clear of moving flight controls. Hydraulic forces are strong enough to cause severe injury.

7-16.1 FLUSHING SERIOUSLY CONTAMINATED FLIGHT CONTROL OR UTILITY HYDRAULIC SYSTEMS (Continued)

7-16.1

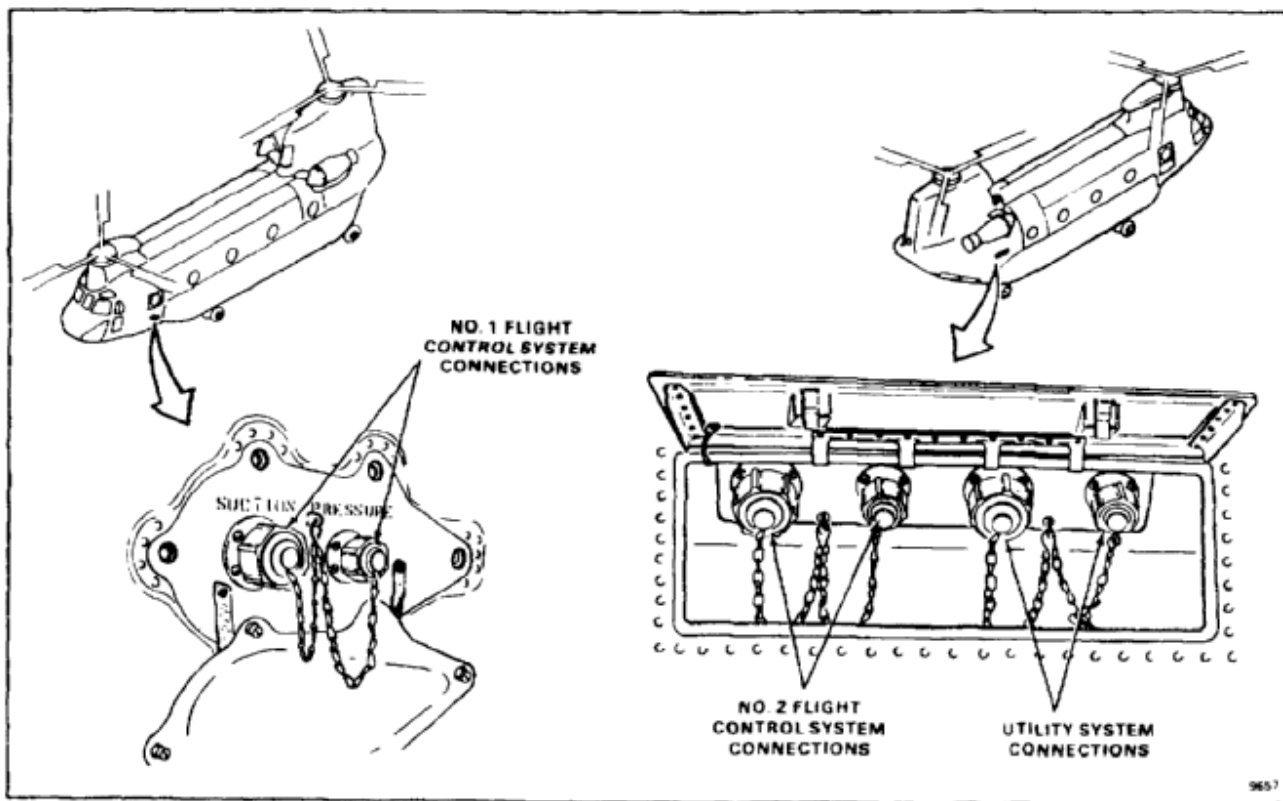

CAUTION

Filter assembly kit ADHT6814-M9716M must be installed in test stand pressure lines. Otherwise, system can be contaminated.

NOTE

To operate hydraulic test stand, refer to applicable manual.

Contamination is any foreign solids, liquids or gaseous material present in the hydraulic fluid.

FLIGHT CONTROL SYSTEM

1. Disconnect return line (1) from hydraulic test stand (2). Position return line in **55 gallon** container (3).
2. Connect test stand (2) to No. 1 flight control external connections (4).
3. Apply external hydraulic power as follows: (Refer to applicable manual.)
 - a. Set tank pressurizing valve to **50 psi**.
 - b. Set relief valve to **3,750 psi**.
 - c. Set volume output to **8 gpm**.
 - d. Set pressure compensator to **3,000 psi**.

CAUTION

Make sure blades are clear of structures and test stand. Otherwise damage to components can occur.

4. Set FLT CONTR switch (5) to No. 1 ON.
5. Set AFCS SYSTEM SEL switch (6) to OFF.
6. Set flight controls (7, 8, and 9) to approximately neutral position.
7. Carefully cycle controls (7, 8, and 9) through full range of travel for **4 minutes**.

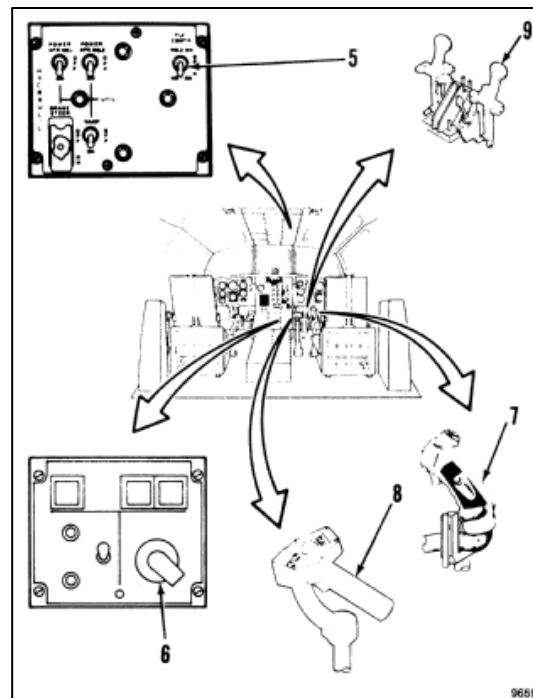
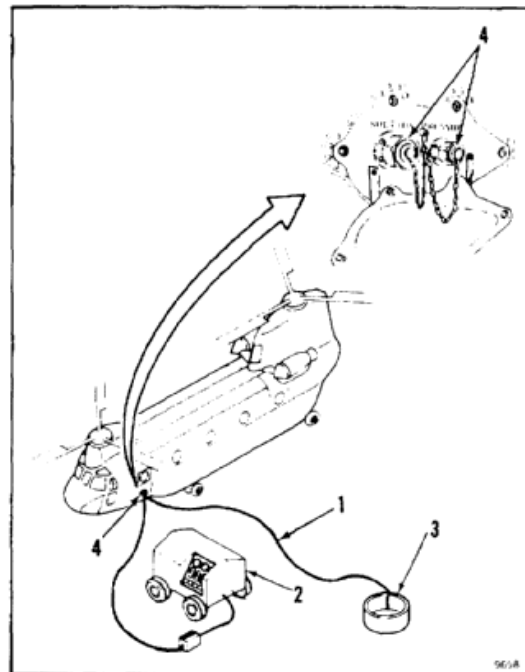

7-16.1 FLUSHING SERIOUSLY CONTAMINATED FLIGHT CONTROL OR UTILITY HYDRAULIC SYSTEMS (Continued)

7-16.1

8. Shut down test stand (2). (Refer to applicable manual.)
9. Empty container (3).
10. Connect return line (1) to test stand (2).
11. Service test stand (2). (Refer to applicable manual.)
12. Service No. 1 Flight Control Hydraulic System Reservoir (Task 1-60).
13. Disconnect test stand (2) from No. 1 flight control external connectors (4).

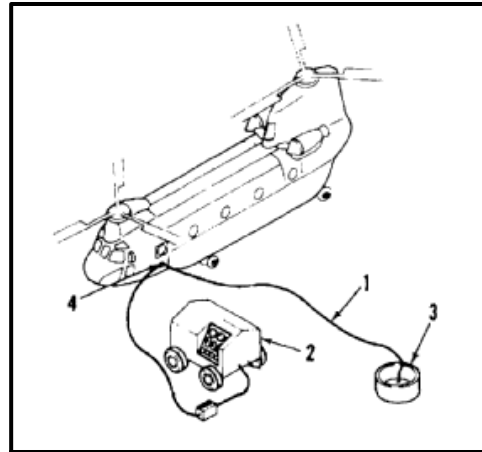

CAUTION

If possible, do not use test stand (2) that was used to flush the No. 1 flight control system. If a second test stand is not available, clean filters before continuing to use first test stand. Refer to applicable manual.

14. Connect second test stand (10), if available, to No. 2 flight control external connections (11).

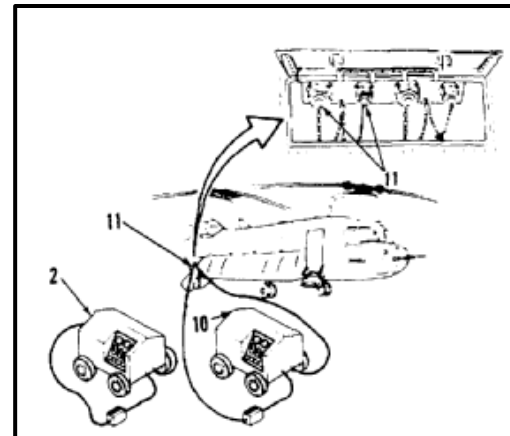

15. Set POWER XFR No. 1 switch (12) to ON.
16. Repeat step 7 for **2 minutes**.
17. Set POWER XFR No. 1 switch (12) to OFF.

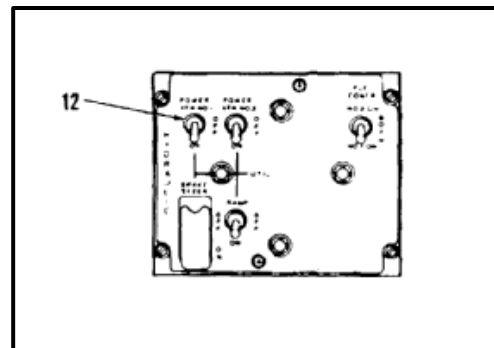

18. Shut down test stand (10). (Refer to applicable manual.)
19. Disconnect test stand (10) from external connection (11).
20. Repeat steps 1 thru 7.
21. Repeat steps 8 thru 13.
22. Repeat steps 1, 2, and 3 for No. 2 flight control system.

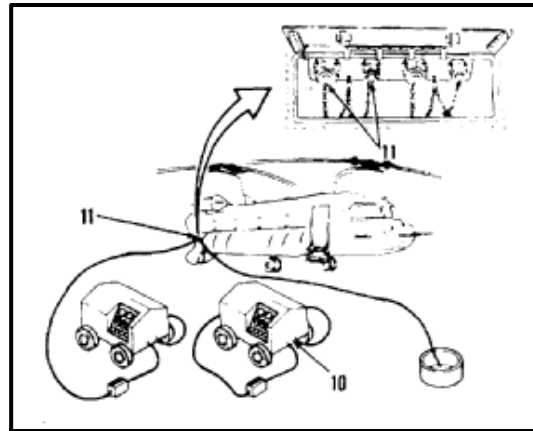

23. Set FLT CONTR switch (5) to No. 2 ON.
24. Repeat steps 6 thru 14 for No. 2 flight control system.
25. Set POWER XFR No. 2 switch (13) to ON.
26. Repeat step 7 for **2 minutes**.
27. Set POWER XFR No. 2 switch (13) to OFF.
28. Repeat steps 18 and 19, then steps 1 thru 7 for No. 2 flight control system.
29. Repeat steps 8 thru 13 for No. 2 flight control system.

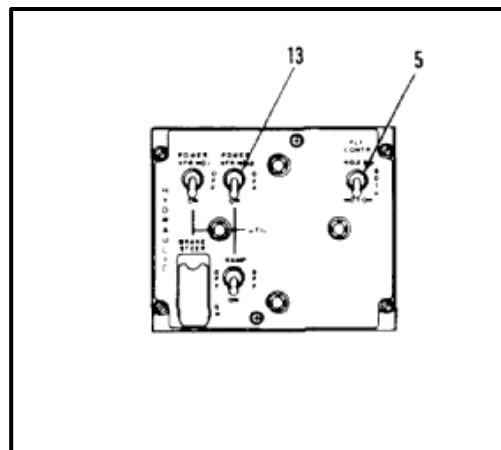

UTILITY SYSTEM

30. Disconnect return line (1) from test stand (2). Position return line in container (3).
31. Connect test stand (2) to utility system external connections (14).
32. Repeat step 3.

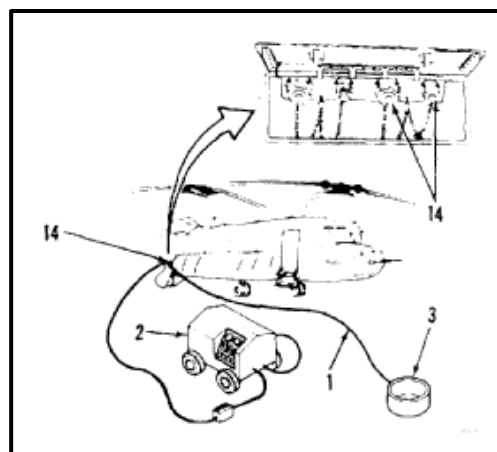

RAMP SYSTEM

- 33. Set RAMP switch (15) to ON.

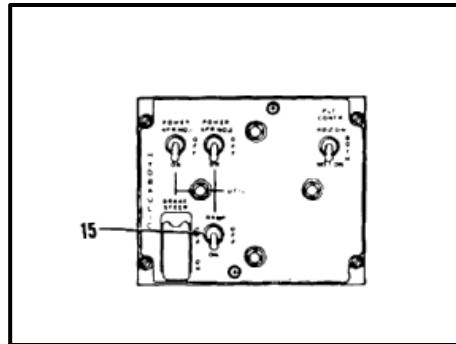

- 34. Turn pin (16) on sequence valve (17) to horizontal position.



Do not cycle cargo door with ramp in full up position. Damage to door and fuselage will occur.

- 35. Set RAMP CONTROL valve handle (18) to DN. When ramp is fully down, set handle to UP.
- 36. Move RAMP CONTROL valve handle (18) to DN. When ramp is at mid position, move handle to STOP.
- 37. Turn pin (16) on sequence valve (17) to vertical position.
- 38. Pull up and hold MANUAL OPER knob (19) on sequence valve (17).
- 39. Release MANUAL OPER knob (19).
- 40. Repeat steps 34 thru 39 **six times**.

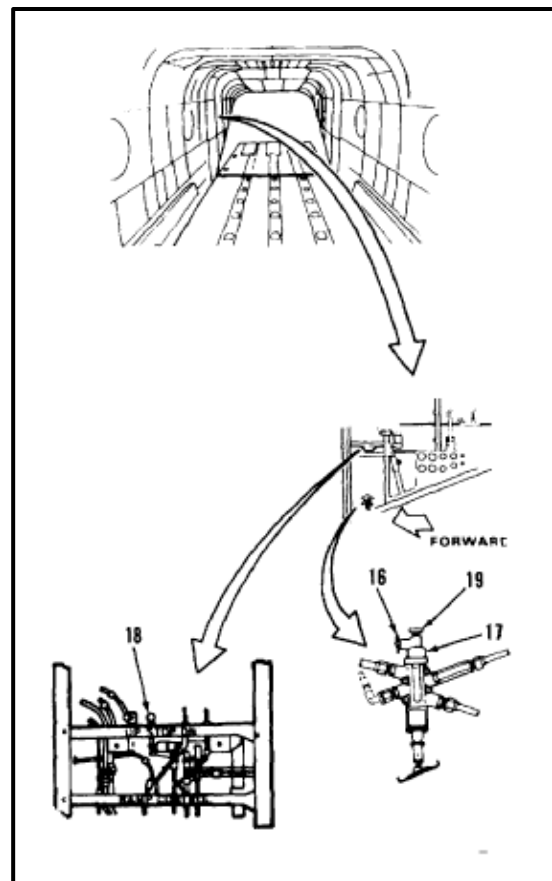

41. Set RAMP switch (15) to OFF.

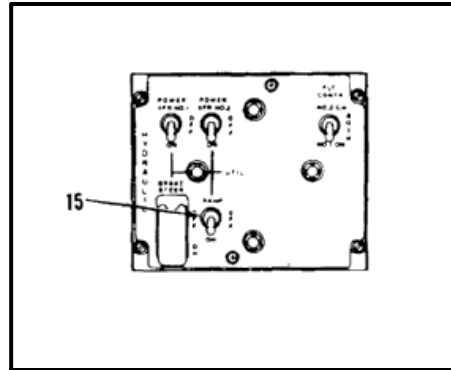

WINCH SYSTEM

42. Remove acoustic panel from heater compartment (Task 2-208). Check that winch shift lever (20) is set to RESCUE.

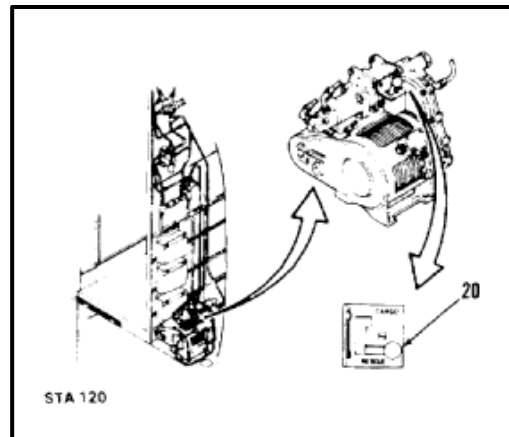

7-16.1 FLUSHING SERIOUSLY CONTAMINATED FLIGHT CONTROL OR UTILITY HYDRAULIC SYSTEMS (Continued)

7-16.1

43. Set HOIST MASTER switch (21) to PILOT.

NOTE

Keep tension on wire rope (cable) when reeling cable. Cable will reel evenly and will not snag.

44. Turn HOIST control (22) to OUT. Reel out about **50 feet** of cable, then release control to OFF.



Do not allow cable end to reel in and jam in a pulley. Damage to winch, pulley, or airframe can occur.

45. Turn HOIST control (22) to IN. Release control to OFF when cable stops reeling in. Have helper keep slight drag on cable. Helper must wear gloves.
46. Repeat steps 44 and 45 **two times**.

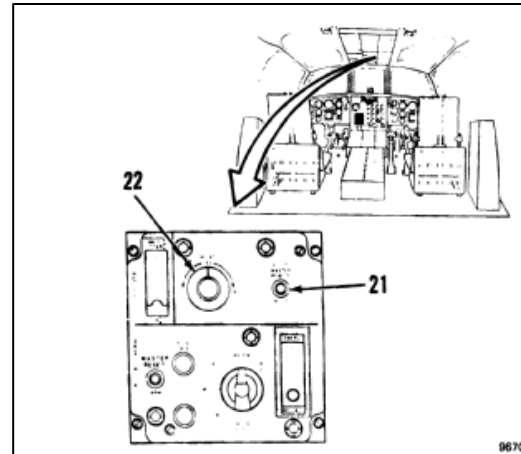
WHEEL BRAKES

47. Press pilot's brake pedals (23) fully down, then release. Repeat **ten times**.
48. Press copilot's brake pedals (24) fully down, then release. Repeat **ten times**.
49. Press pilot's brake pedals (23). Pull out parking brake handle (25) and release. Repeat **ten times**.
50. Release pilot's pedals (23) with handle (25) pushed in.

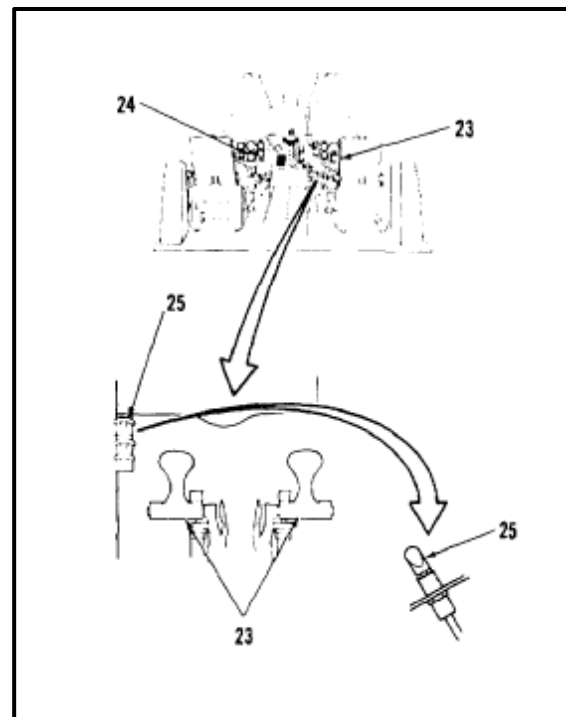

51. Working at right forward landing gear, connect bleed hoses (26) to bleed fittings (27) of two wheel brake cylinders (28 and 29). Position hoses in **two quart** container (30).
52. Loosen two bleed fittings (27).
53. Have helper in cockpit, push then release pilot's brake pedals until approximately **1 pint** of fluid is drained from bleed fittings (27).
54. Tighten bleed fittings (27). Remove bleed hoses (26).
55. Repeat steps 51 thru 54 for left forward landing gear.

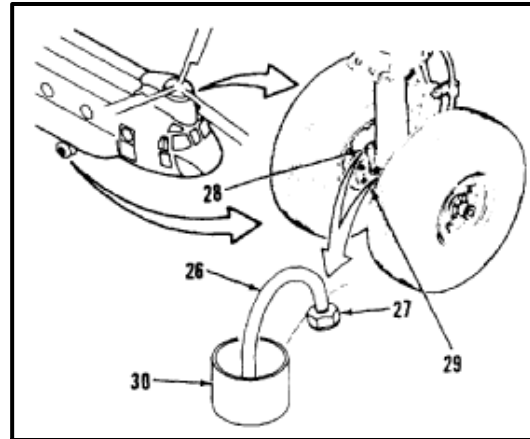

56. Working at right aft landing gear, connect bleed hose (26) to bleed fitting (31) of wheel brake cylinder (32). Position hose in container (30).
57. Repeat steps 52 and 53 for bleed fitting (31).
58. Tighten bleed fitting (31). Remove bleed hose (26).
59. Repeat steps 56, 57 and 58 for left aft landing gear.

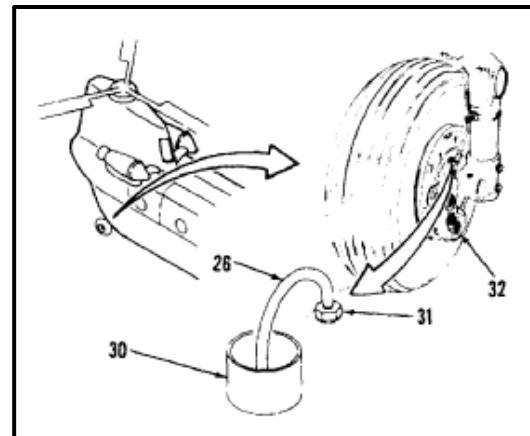

CARGO HOOK

60. Open rescue hatch access panel (33) (Task 2-2).
61. Position rescue hatch door (34) at lowest position (Task 2-193).
62. Unstow cargo hook (35).

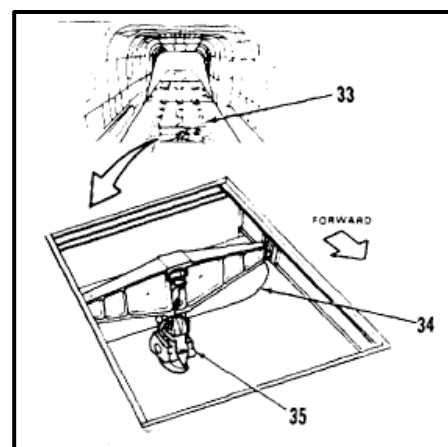

7-16.1 FLUSHING SERIOUSLY CONTAMINATED FLIGHT CONTROL OR UTILITY HYDRAULIC SYSTEMS (Continued)

7-16.1

63. Set hook select switch (36) in cockpit to MID.
- 63.1. Set MASTER switch (39) to ARM.
64. Press and release pilot's CARGO HOOK RELEASE switch (37) on cyclic stick grip (38).
65. Set MASTER switch (39) to RESET, then to ARM.
66. Repeat steps 64 and 65 **three times**.

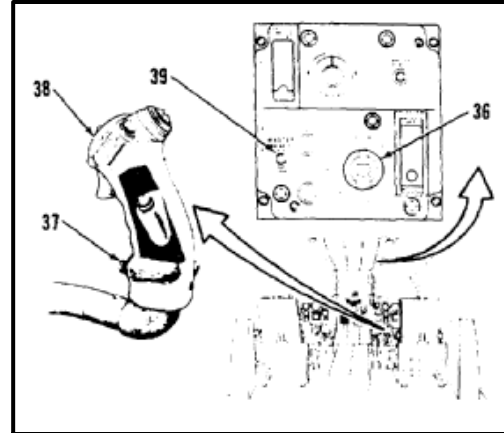

67. Reduce external hydraulic pressure to **500 psi**.
68. Disconnect hydraulic hose (40) from cargo hook (35). Position hose in container (30).
69. Repeat step 64.
70. After approximately **1 gallon** of fluid has drained, repeat step 65.
71. Connect hose (40) to cargo hook (35). Leave nut (41) loose.
72. Repeat step 64. Allow fluid to flow at nut (41) until air free. Tighten nut. Use cloths (E120) to catch spilled fluid. Wear gloves (E186).

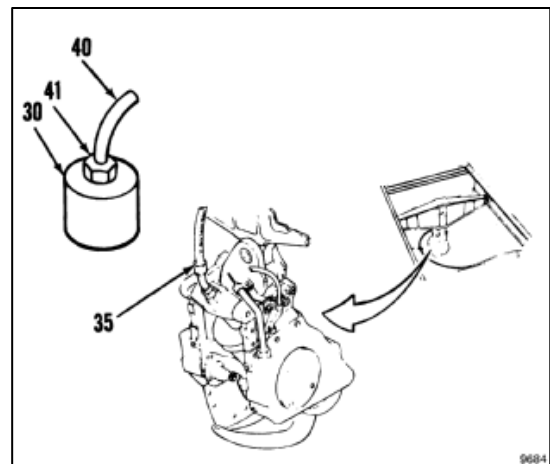

73. Set MASTER switch (39) to OFF.
74. Increase external hydraulic pressure to **3,000 psi**.

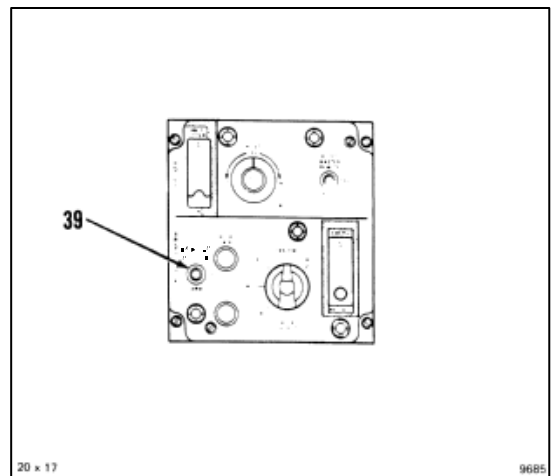

POWER STEERING

75. Jack right rear landing gear (Task 1-24). Check wheel (42) is free to rotate.

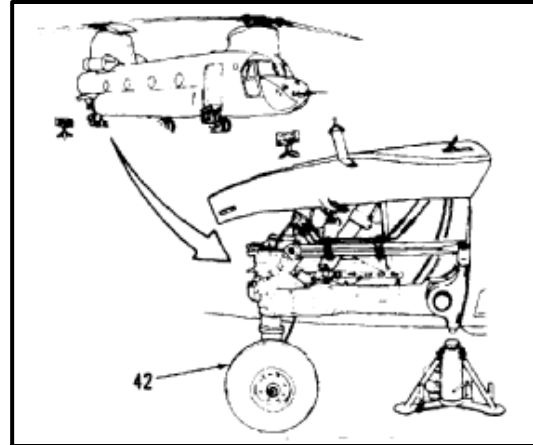
**WARNING**

Keep personnel clear of landing gear.
Injury can occur when wheel is turned.

- 75.1. Set BRK steer switch (42.1) to ON.
76. Set swivel switch (43) in cockpit to lock, then UNLOCK. Repeat **six times**.
77. Set SWIVEL switch (43) to STEER.
78. Slowly rotate STEERING CONTROL knob (44) fully left, then fully right. Repeat **three times**.
79. Set knob (44) to neutral (center) position.
80. Set SWIVEL switch (43) to LOCK.
81. Remove jack from landing gear (Task 1-24).

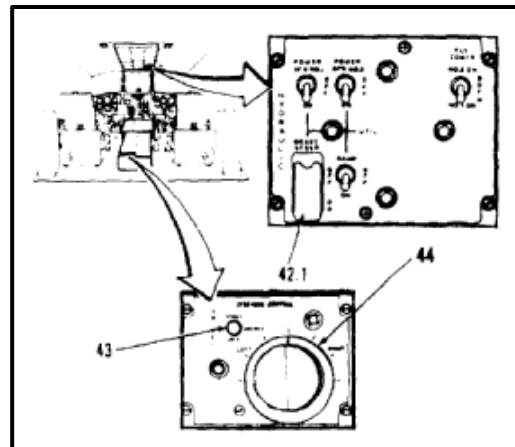

ENGINE START WITHOUT 74

82. Position ENGINE CONTROL No. 1 and No. 2 levers (45) in cockpit to STOP.

WARNING

Make sure that rotor blades are clear of obstructions and that personnel are aware that rotor blades may turn during engine motoring. Turning blades can cause damage or serious injury to personnel.

CAUTION

Make sure blades are clear of obstructions. Otherwise, damage to components can occur.

83. Set ENGINE 1 START switch (46) to MOTOR. Allow engine to motor for **15 seconds**.
84. Set ENGINE 1 START switch (46) to OFF.
85. Set ENGINE 2 START switch (47) to MOTOR. Allow engine to motor for **15 seconds**.
86. Set ENGINE 2 START switch (47) to OFF.

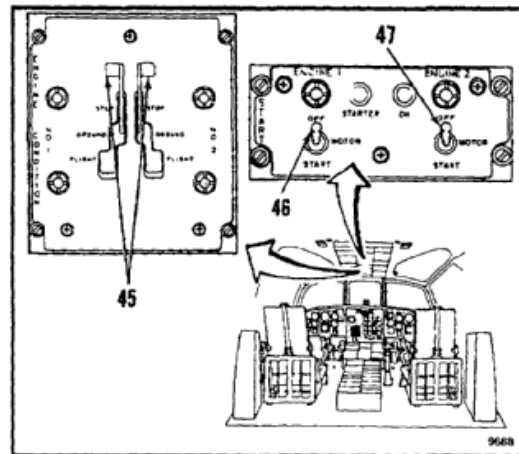

ENGINE START WITH 74

- 86.1. Set ENGINE CONDITION NO. 1 and NO. 2 levers (45) to STOP.

WARNING

Make sure that rotor blades are clear of obstructions and that personnel are aware that rotor blades may turn during engine motoring. Turning blades can cause damage or serious injury to personnel.

CAUTION

Make sure blades are clear of obstructions. Otherwise, damage to components can occur.

- 86.2. Set ENG START switch (76) to 1 (46). Allow engine to motor for **15 seconds**.
- 86.3. Set ENG START switch (76) to center (off).
- 86.4. Set ENG START switch (76) to 2 (47). Allow engine to motor for **15 seconds**.
- 86.5. Set ENG START switch (76) to center (off).

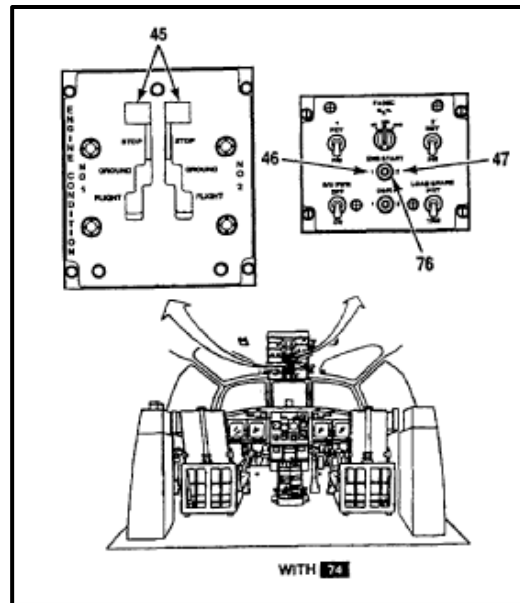

POWER TRANSFER UNIT

- 87. Service Utility Hydraulic System Reservoir (Task 1-59).
- 88. Service No. 1 and No. 2 Flight Control Hydraulic System Reservoirs (Tasks 1-60 and 1-61).
- 89. Set POWER XFR No. 1 switch (12) to ON. After **2 minutes**, set switch to OFF.
- 90. Set POWER XFR No. 2 switch (13) to ON. After **2 minutes**, set switch to OFF.

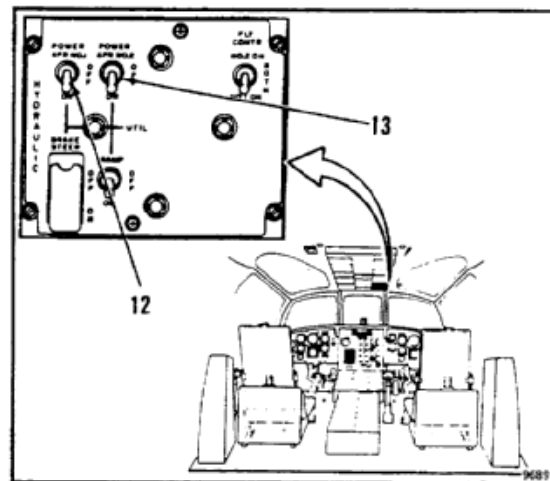

7-16.1 FLUSHING SERIOUSLY CONTAMINATED FLIGHT CONTROL OR UTILITY HYDRAULIC SYSTEMS (Continued)

7-16.1

APU MOTOR PUMP

- 91. In ramp area, disconnect exciter cable (48) from spark plug (49) of APU (50).
- 92. Close APU fuel shut-off valve (51).

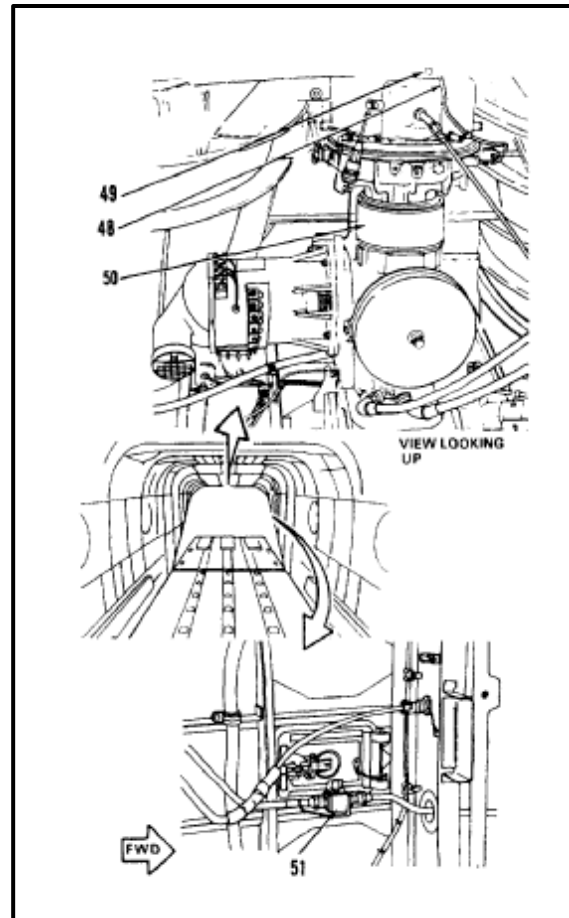

- 93. Set APU switch (52) to RUN. HOLD at RUN for a maximum of **15 seconds**, then set switch to OFF.

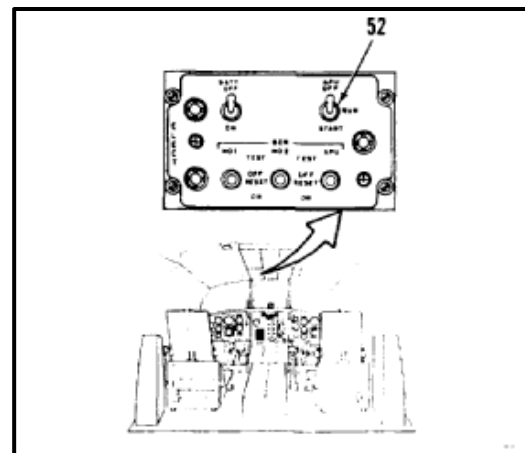

- 94. Connect exciter cable (48) to APU spark plug (49).
- 95. Open APU fuel shut-off valve (51).

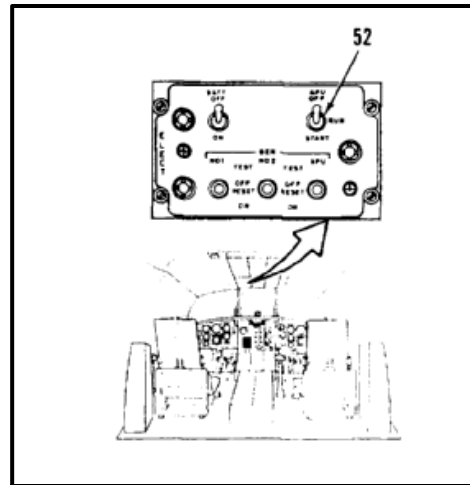

APU START ACCUMULATOR

- 96. Check APU start accumulator gage (53) in ramp area indicates between **1800 and 2050 psi**.
- 97. Turn EMERG UTIL PRESS valve handle (54) to OPEN.
- 98. Press depressurization valve (55) on APU start module (56). Hold until sound of depressurizing has stopped. Release valve.
- 99. Allow APU accumulator air-charge valve (57) to fill.
- 100. Repeat steps 98 and 99 **five times**.
- 101. Turn EMERG UTIL PRESS valve handle (54) to NORMAL.
- 102. Shut down external hydraulic power. (Refer to applicable manual.)

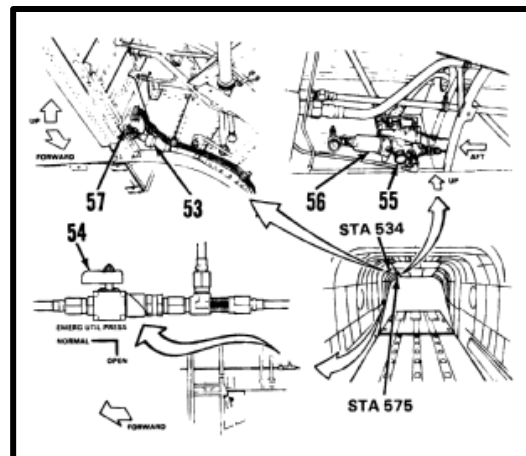

7-16.1 FLUSHING SERIOUSLY CONTAMINATED FLIGHT CONTROL OR UTILITY HYDRAULIC SYSTEMS (Continued)

7-16.1

FLIGHT CONTROL AND UTILITY HYDRAULIC PUMPS
NOTE

The three pumps may be flushed at the same time or individually, depending on number of personnel and equipment available. This procedure flushes three pumps at the same time.

103. Remove forward transmission drip pan (Task 2-3).
104. Disconnect pressure hose (58) in cockpit passage tubing (59) of No. 1 flight control pump (60). Use **two gallon** container (61) and cloths (E120) for spilled fluid. Wear gloves (E186).
105. Position cargo ramp open and level (TM 55-1520-240-T).
106. Open left aft transmission access door (62) (Task 2-2).
107. Working from ramp, disconnect pressure hose (63) from tubing (64) of No. 2 flight control pump (65). Use **two gallon** container (66) and cloths (E120) for spilled fluid. Use gloves (E186).

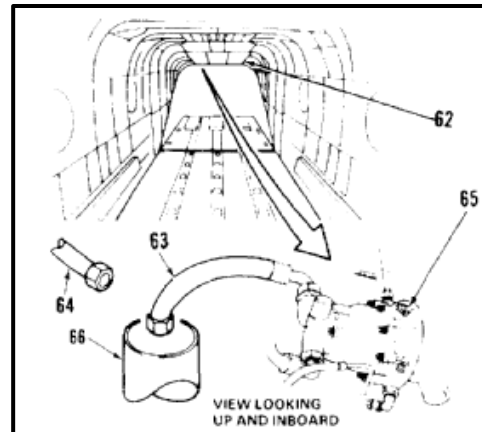
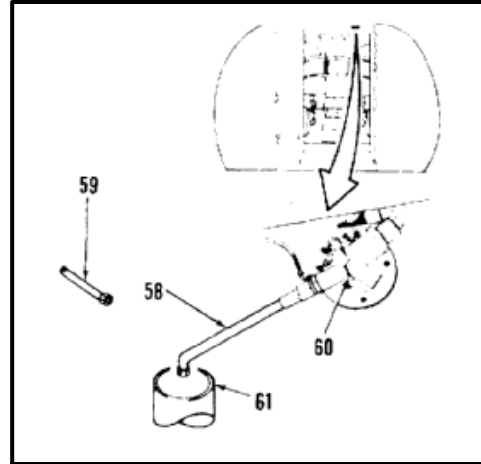

7-16.1 FLUSHING SERIOUSLY CONTAMINATED FLIGHT CONTROL OR UTILITY HYDRAULIC SYSTEMS (Continued)

- 108. Open right aft transmission access door (67) (Task 2-2).
- 109. Disconnect pressure hose (68) from check valve (69) of utility pump (70). Use container for spilled fluid.
- 110. Remove valve (69) and packings (71 and 72) from pump (70).
- 111. Deleted.
- 112. Position **2 gallon** container (73) under pump (70). Insert hose (68) in container (73).

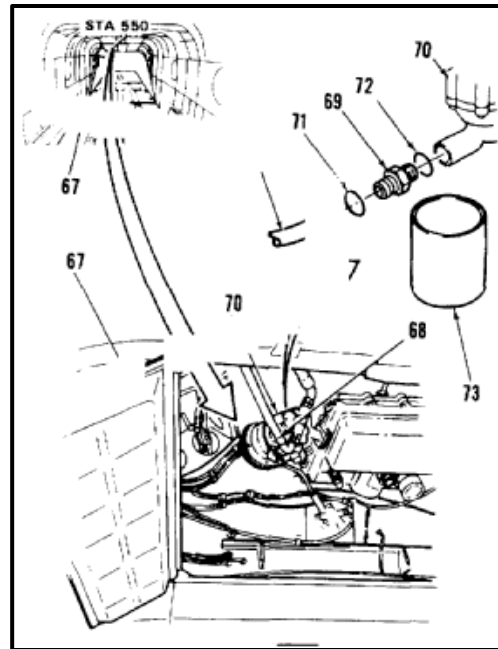

- 113. Install tiedown lines (74) on forward rotary wing blades (Task 1-26).
- 114. Rotate the rotary wing heads (75) until approximately **1 gallon** of fluid has drained into containers.

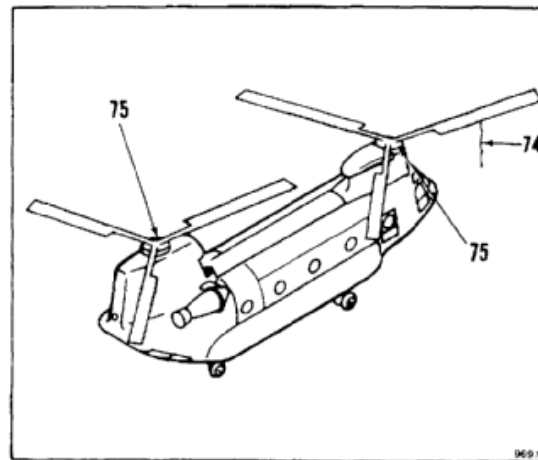

7-16.1 FLUSHING SERIOUSLY CONTAMINATED FLIGHT CONTROL OR UTILITY HYDRAULIC SYSTEMS (Continued)

7-16.1

- 115. Deleted.
- 116. Install packings (71 and 72) on valve (69).
- 117. Install valve (69) in pump (70).
- 118. Connect hose (68) to valve (69).
- 119. Remove container (73).

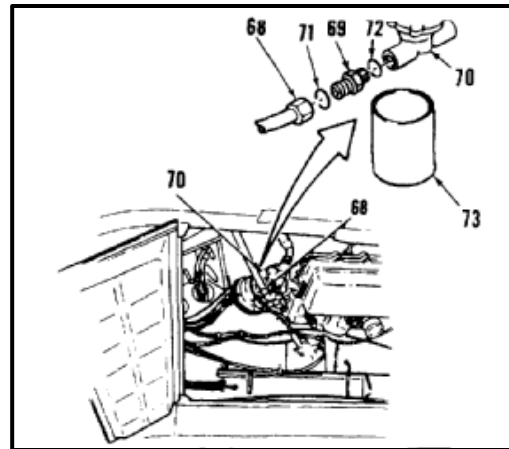

- 120. Connect hose (63) of pump (65) to tubing (64).
- 121. Remove container (66).

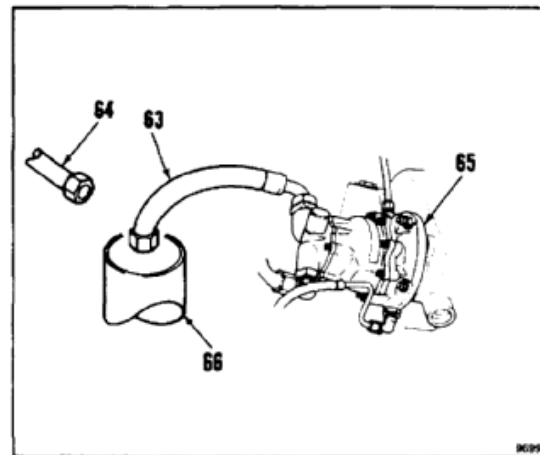

- 122. Connect hose (58) of pump (60) to tubing (59).
- 123. Service Utility Hydraulic System Reservoir (Task 1-59).
- 124. Service No. 1 and No. 2 Flight Control Hydraulic System Reservoirs (Tasks 1-60 and 1-61).
- 125. Remove container (61).

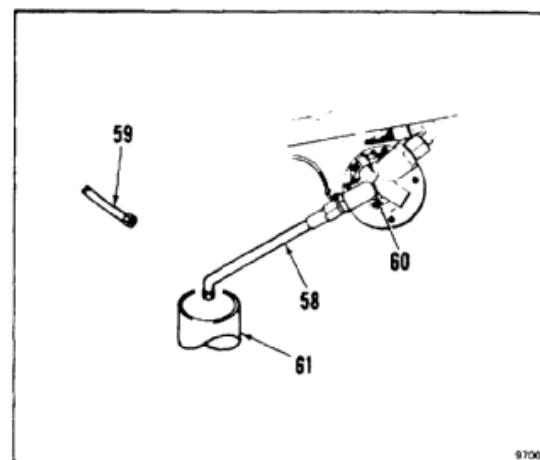

FOLLOW-ON MAINTENANCE:

Perform operational check of flight control and utility hydraulic system (TM 55-1520-240-T).

Sample hydraulic fluid from flight control and utility system (Task 7-8.1).

Close left and right aft transmission access doors (Task 2-2).

Install forward transmission drip pan (Task 2-3).

Close rescue hatch access door (Task 2-2).

Install rescue hatch access panel (Task 2-2).

Disconnect hydraulic test stand (Task 1-38).

Disconnect external electrical power (Task 1-37).

END OF TASK

7-16.2 FILLING AND BLEEDING FLIGHT CONTROL HYDRAULIC SYSTEMS (WITHOUT EXTERNAL POWER)

7-16.2

INITIAL SETUP**Applicable Configurations:**

All

Tools:

Hydraulic Repairer's Tool Kit, NSN 5180-00-323-4891
 Containers, 2 Quart
 Hand Oiler
 Workstand

Materials:

Hydraulic Fluid (E199)
 Bleed Hose (Tubing) (E428)
 Cloths (E120)
 Lockwire (E231)
 Gloves (E186)

Personnel Required:

Medium Helicopter Repairer
 Aircraft Pneudraulics Repairer
 Inspector

References:

Task 1-36
 Task 1-61
 Task 1-63
 Task 7-22
 Task 7-23
 Task 7-27
 Task 7-28

Equipment Condition:

Flight Control System Accumulators Serviced (Task 1-63)
 Flight Control Hydraulic System Reservoirs Serviced (Tasks 1-60, 1-61, or 1-62)
 Flight Control Hydraulic Systems Flushed (Tasks 7-10, 7-11, 7-12, 7-13, 7-14)
 Utility Hydraulic System Filled and Bled (Task 7-335)
 Battery Connected (Task 1-39)
 Electrical Power On
 Hydraulic Power Off
 Right Forward Work Platform Open (Task 2-2)
 Left Pylon Access Door Open (Task 2-2)
 Forward Transmission Drip Pan Removed (Task 2-3)
 Left Transmission Baffle Open (Task 2-2)
 Controls Closet Acoustic Blanket Removed (Task 2-107)
 Tiedown Line Attached to Forward Blades (Task 1-26)

General Safety Instructions:

WARNING

Hydraulic fluid (E199) is toxic. It can irritate skin and cause burns. Avoid inhaling. Use only with adequate ventilation. Avoid contact with skin, eyes, or clothing. In case of contact, immediately flush skin or eyes with water for at least **15 minutes**. Get medical attention for eyes.

Hydraulic fluid ejected under pressure can cause injury to personnel. Hydraulic fluid sprayed into the air is a fire hazard.

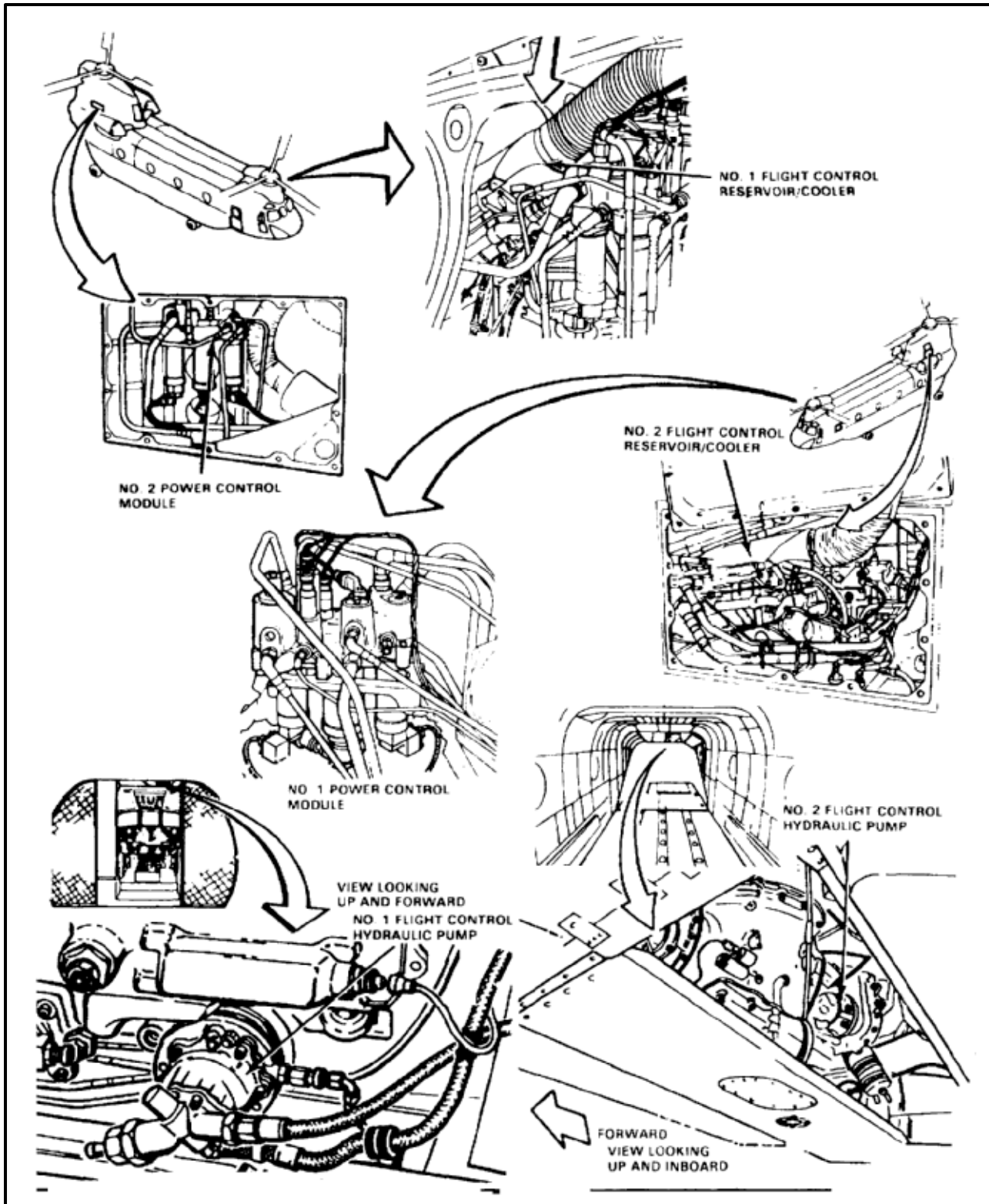

7-16.2 FILLING AND BLEEDING FLIGHT CONTROL HYDRAULIC SYSTEMS (WITHOUT EXTERNAL POWER) (Continued)

7-16.2

NOTE

Throughout this task, whenever a connection is loosened to let air escape from a hydraulic line, use a container and cloths (E120) to catch spilled fluid. Wear gloves (E186).

NO. 1 SYSTEM

1. Bleed flight control hydraulic pump (1) as follows:
 - a. Disconnect drain tube (2) from case drain port (3) of pump.
 - b. Fill pump with hydraulic fluid (E199) through port (3). Use hand oiler.
 - c. Connect tube (2) to port (3).
 - d. Loosen case drain fitting (4) at power control module (5).
 - e. Have helper rotate rotor blades through at least **ten complete turns** by pulling blades around in normal direction. Use blade tiedown lines on forward blades.
 - f. While blades are being turned, let fluid flow from case drain fitting (4) until air-free. Tighten fitting.
2. Operate the APU (Task 1-36).
3. Set POWER XFR NO. 1 switch (6) on cockpit HYDRAULIC panel (7) to ON. Set FLT CONTR switch (8) to NO. 1 ON.

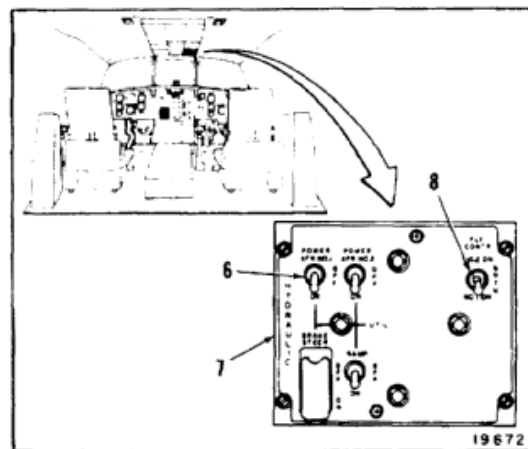
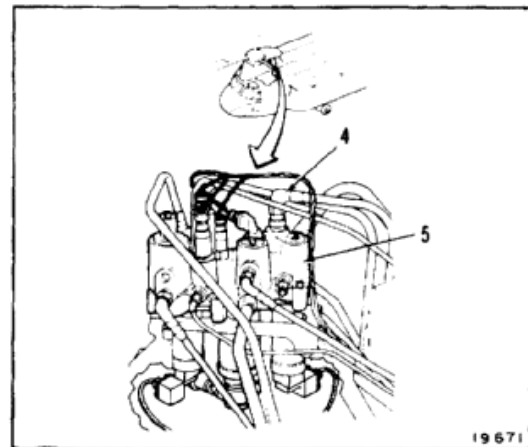
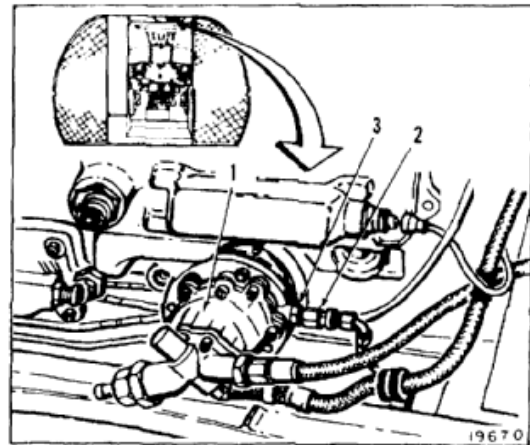

4. In cockpit, slowly cycle thrust control (14), cyclic control (15), and yaw pedals (16) for **5 minutes**.

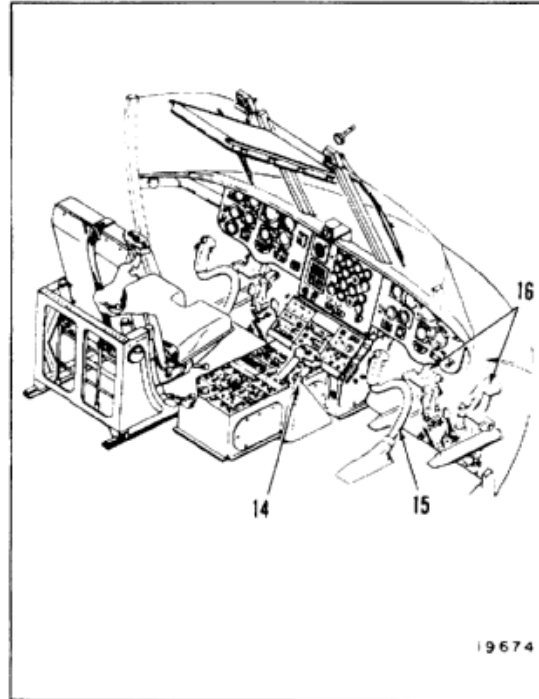

5. Bleed the No. 1 (upper) extensible links (9) on each ILCA (10) as follows:
 - a. Set SYSTEM SEL switch (11) on cockpit center console AFCS panel (12) to OFF.
 - b. Remove lockwire from bleed plug (13) on each ILCA. Loosen plug and let fluid flow until air-free.
 - c. Tighten bleed plug (13) and install lockwire (E231).

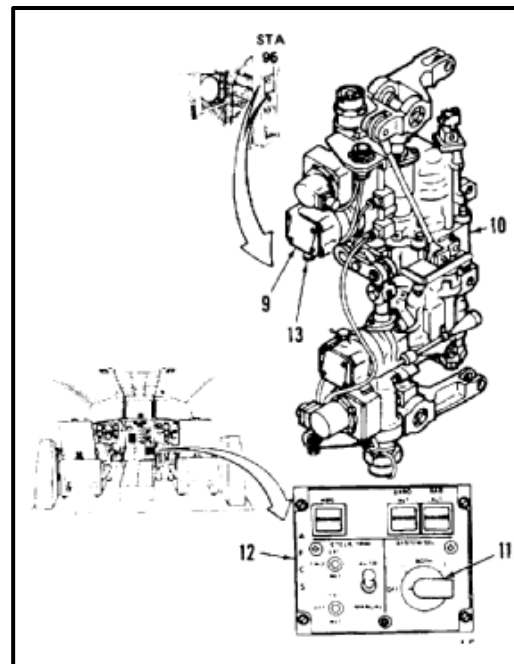

7-16.2 FILLING AND BLEEDING FLIGHT CONTROL HYDRAULIC SYSTEMS (WITHOUT EXTERNAL POWER) (Continued)

7-16.2

6. Bleed air from No. 1 system reservoir/cooler (17) as follows:
 - a. Loosen clamp (18) and disconnect hose (19) from bleed valve (20). Connect bleed hose (21) to valve.
 - b. Open bleed valve (20). Let fluid flow until air-free. Close valve.
 - c. Service reservoir (Task 1-60 or 1-62).
7. Repeat steps 4 and 6 until no air is in fluid flowing from bleed valve (20).
8. Remove bleed hose (21). Connect hose (19) to valve (20). Tighten clamp (18).
9. Shut down the APU (Task 1-36).
10. If No. 2 system will not be bled, go to Follow-On Maintenance.

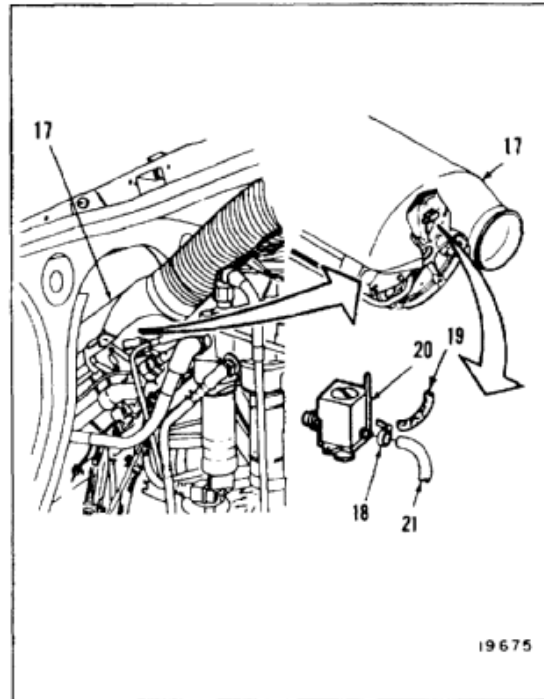

NO. 2 SYSTEM

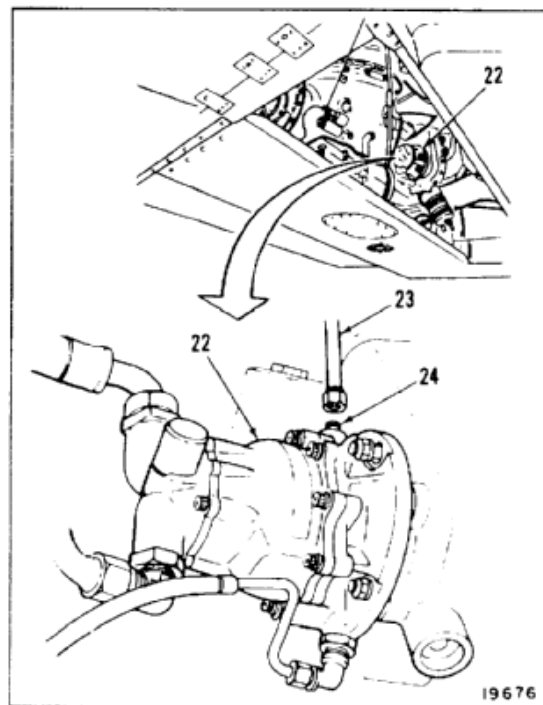
11. Bleed flight control hydraulic pump (22) as follows:
 - a. Disconnect drain tube (23) from case drain port (24) of pump.
 - b. Fill pump with hydraulic fluid (E199) through port (24). Use hand oiler.
 - c. Connect tube (23) to port (24).

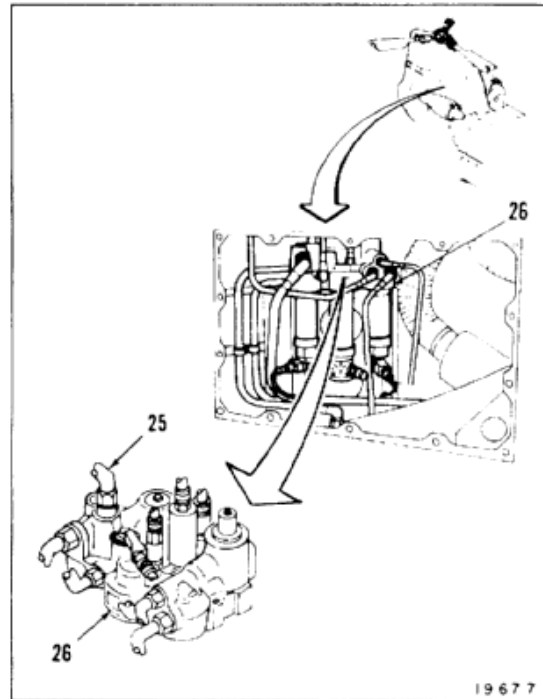

7-16.2 FILLING AND BLEEDING FLIGHT CONTROL HYDRAULIC SYSTEMS (WITHOUT EXTERNAL POWER) (Continued)

- d. Loosen case drain fitting (25) at power control module (26).
- e. Have helper rotate rotor blades through at least **ten complete turns** by pulling blades around in normal direction. Use blade tiedown lines on forward blades.
- f. While blades are being turned, let fluid flow from case drain fitting (25) until air-free. Tighten fitting.



- 12. Operate the APU (Task 1-36).
- 13. Set POWER XFR NO. 2 switch (6) on cockpit HYDRAULIC panel (7) to ON. Set FLT CONTR switch (8) to NO. 2 ON.

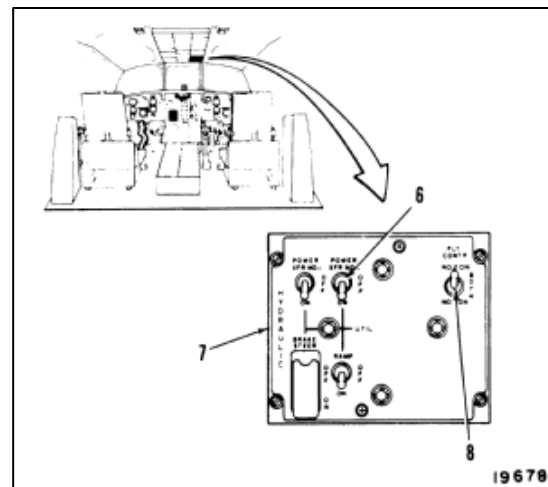

7-16.2 FILLING AND BLEEDING FLIGHT CONTROL HYDRAULIC SYSTEMS (WITHOUT EXTERNAL POWER) (Continued)

7-16.2

14. In cockpit, slowly cycle thrust control (14), cyclic control (15), and yaw pedals (16) for **5 minutes**.

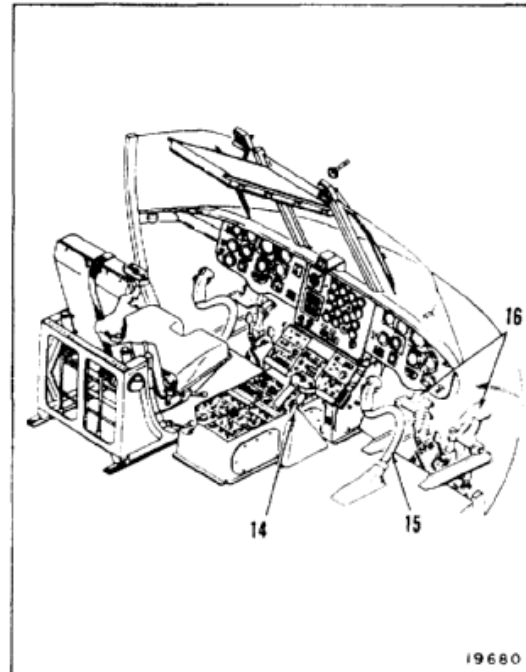

15. Bleed the No. 2 (lower) extensible links (27) on each ILCA (10) as follows:
- Set SYSTEM SEL switch (11) on cockpit center console AFCS panel (12) to OFF.
 - Remove lockwire from bleed plug (28) on each ILCA. Loosen plug and let fluid flow until air-free.
 - Tighten bleed plug (28) and install lockwire (E231).

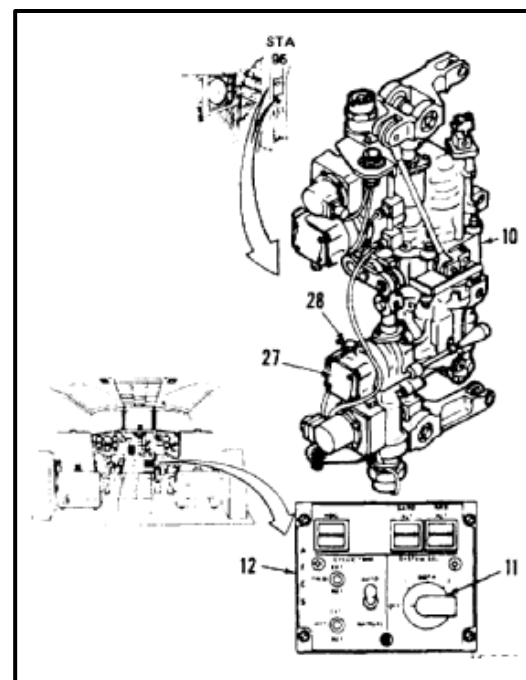

16. Bleed air from No. 2 system reservoir/cooler (29) as follows:
 - a. Loosen clamp (30) and disconnect hose (31) from bleed valve (32). Connect bleed hose (33) to valve.
 - b. Open bleed valve (32). Let fluid flow until air-free. Close valve.
 - c. Service reservoir (Task 1-60 or 1-62).
17. Repeat steps 14 and 16 until no air is in fluid flowing from bleed valve (32).
18. Remove bleed hose (33). Connect hose (31) to valve (32). Tighten clamp (30).
19. Shut down the APU (Task 1-36).

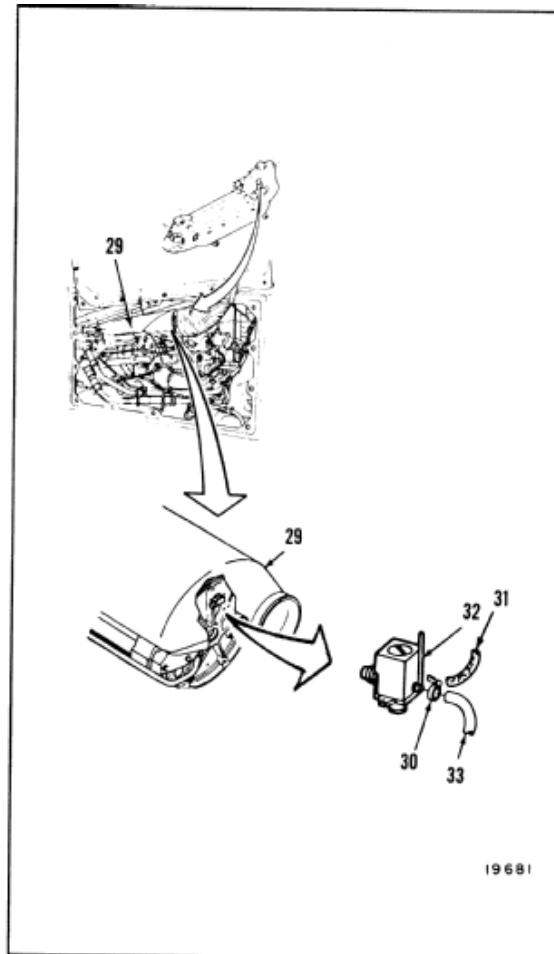
**FOLLOW-ON MAINTENANCE:**

- Perform operational check of flight control hydraulic systems (TM 55-1520-240-T).
- Remove electrical power off.
- Close right forward work platform (Task 2-2)
- Close left pylon access door (Task 2-2).
- Install forward transmission drip pan (Task 2-3).
- Close left transmission baffle (Task 2-2).
- Install controls closet acoustic blanket (Task 2-108).
- Install controls closet panel (Task 2-2).

END OF TASK

INITIAL SETUP

Applicable Configurations:

All

Tools:

Aircraft Mechanic's Tool Kit, NSN 5180-00-323-4692

Materials:Cloths (E120)
Gloves (E186)**Personnel Required:**

Medium Helicopter Repairer

Equipment Condition:Battery Disconnected (Task 1-39)
Electrical Power Off
Hydraulic Power Off
Utility Hydraulic System Depressurized (Task 7-135.1)
Cargo Ramp Open and Level (TM 55-1520-240-T)**General Safety Instructions:****WARNING**

Hydraulic fluid (E199) is toxic. It can irritate skin and cause burns. Avoid inhaling. Use only with adequate ventilation. Avoid contact with skin, eyes, or clothing. In case of contact, immediately flush skin or eyes with water for at least **15 minutes**. Get medical attention for eyes.

1. Rotate valve handle (1) counterclockwise to OFF position.
2. Remove screw (2) from two clamps (3).
3. Disconnect three tubes (4) from unions (5). Use cloths (E120) for spilled fluid. Use gloves (E186).
4. Remove three unions (5) and packings (6) from valve (7).

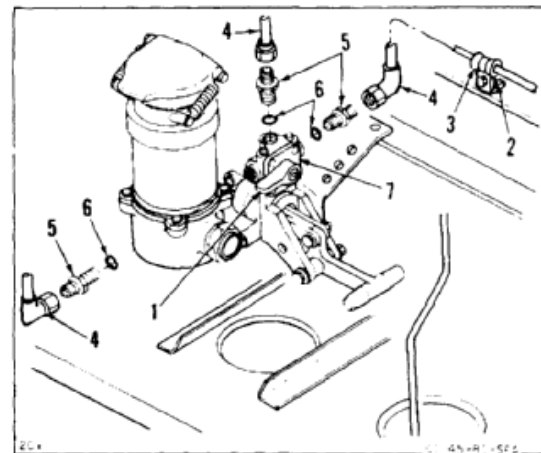
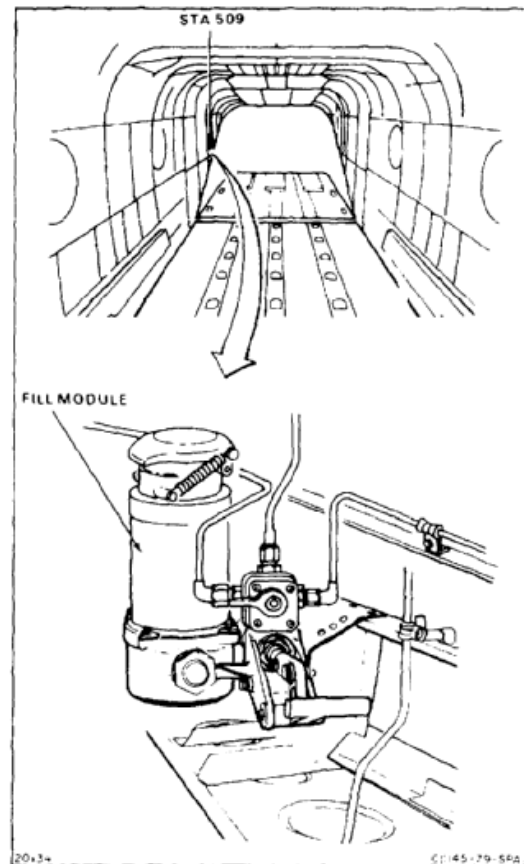

5. Remove three bolts (8) and washers (9). Remove module (10).

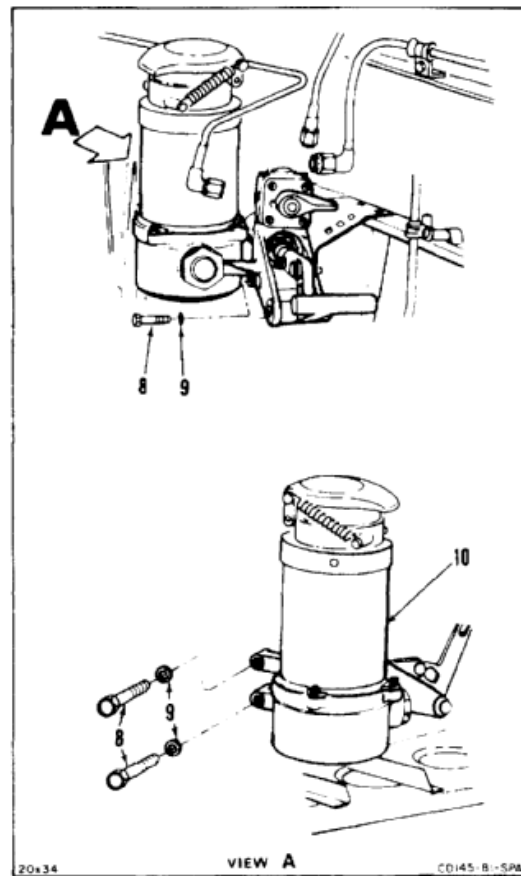

FOLLOW-ON MAINTENANCE:

None

END OF TASK

7-134

INITIAL SETUP

Applicable Configurations:

All

Tools:

Hydraulic Repairer's Tool Kit, NSN 5180-00-323-4891
 Socket, 1 Inch
 Socket Key, 7/64 Inch
 Soft Jawed Vise
 Retaining Ring Pliers
 Adapter, 3/8 to 1/2 Inch
 Drift Pin, Straight 3/16 Inch
 Technical Inspection Tool Kit, NSN 5180-00-323-5114
 Outside Micrometer Calipers, 0 to 1 Inch
 Hole Gage, 0.200 to 0.300 Inch

Materials:

Lockwire (E230)

Personnel Required:

Aircraft Pneudraulics Repairer
 Inspector

Equipment Condition:

Off Helicopter Task

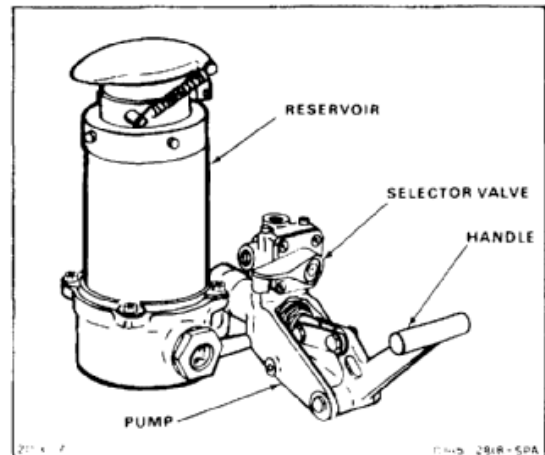
**NOTE**

General inspection criteria (Task 7-1.1) for obvious damage applies unless otherwise stated.

Inspection steps cover parts that are subject to wear.

DISASSEMBLE AND INSPECT HANDLE

1. Remove cotter pin (1), nut (2), and bolt (3).
2. Remove two cotter pins (4), nuts (5), and bolts (6). Remove two links (7).
- 2.1. Measure holes in two links (7). Diameter shall not be more than **0.253 inch**.
3. Remove sleeve (8). Remove handle (9) from housing (10).
- 3.1. Measure diameter of sleeve (8). Inside diameter shall not be more than **0.253 inch**. Outside diameter shall not be less than **0.372 inch**.
- 3.2. Remove bushing (11) and two bushings (11.1) from handle (9). Use drift pin.

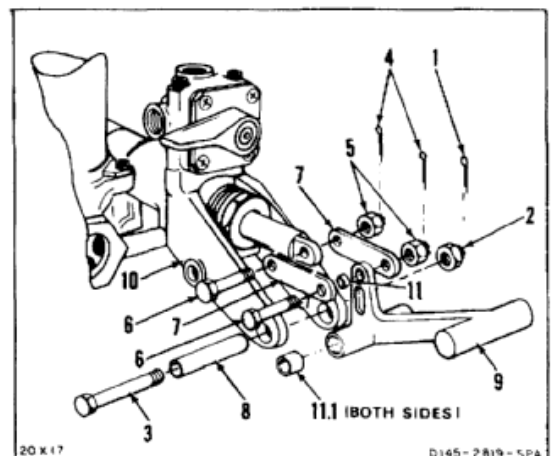

- 3.3. Measure inside diameter of small bushing (11). Diameter shall not be more than **0.253 inch**.
4. Measure inside diameter of two bushings (11.1). Diameter shall not be more than **0.375 inch**.

DISASSEMBLE SELECTOR VALVE

5. Remove lockwire and remove three screws (12).
6. Remove valve (13) from housing (10).
7. Remove transfer tube (14) from valve (13) or housing (10). Remove two packings (15) from transfer tube.

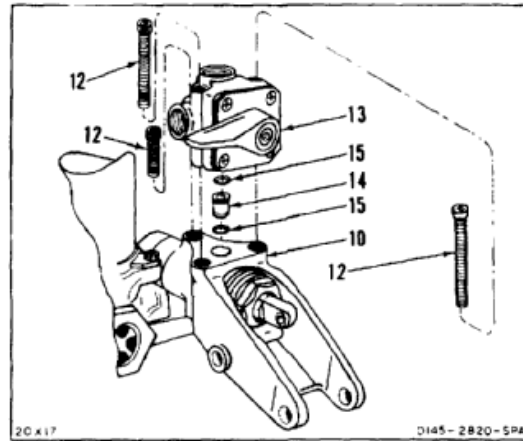

8. Remove lockwire from screw (16).
9. Press handle (17) towards valve (13) and remove screw (16).
10. Slide handle (17) from valve (13). Remove ball (18) and spring (19) from handle. Remove shim (19.1) (if installed).

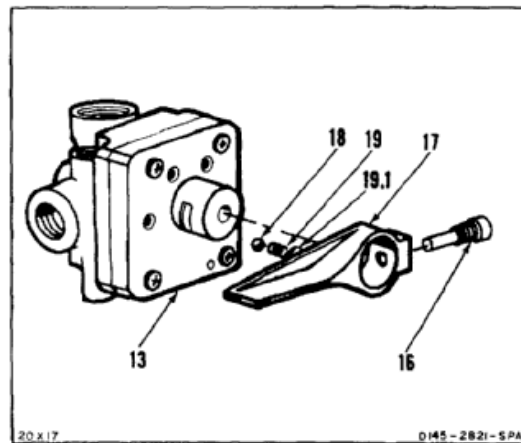

11. Remove four screws (20) from valve (13).
12. Work and remove cover (21) and rotor (22) from valve (13).

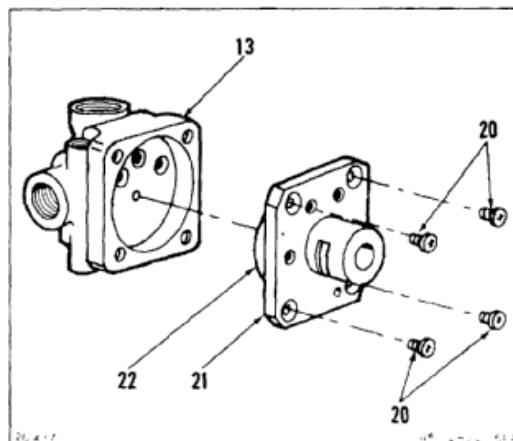

13. Remove rotor (22) from cover (21).
- 13.1. Inspect back face of rotor (22). Back face is a lapped surface. It shall have no nicks or scratches.
14. Remove packing (23), and washer (24) from rotor (22).
- 14.1. Inspect Teflon washer (24). There shall be no cuts or tears. Washer shall be no less than **0.060 inch** thick over entire face.
15. Remove packing (25) from cover (21).

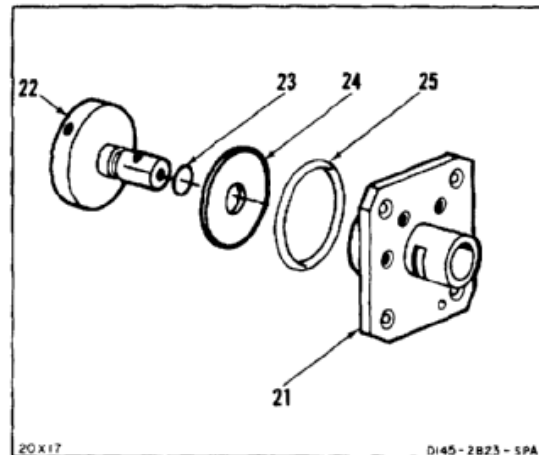

16. Remove three seals (26) and springs (27) from valve (13). Use lockwire (E230) bent **90°** at one end. Place bent end through hole in seal, and slide out seal and spring.

NOTE

A different number of shims may be under each spring.

- 16.1. Remove shims (27.1) from under springs (27). Tag shims with each spring and seal (26).
17. Remove three packings (28) from seals (26).
- 17.1. Inspect face of seals (26) that faces away from valve (13). Face is a lapped surface. It shall have no nicks or scratches.

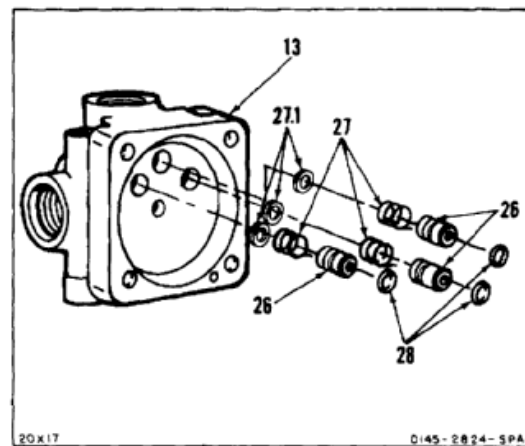

DISASSEMBLE PUMP

18. Remove lockwire and three screws (29) from housing (10). Remove housing from reservoir base (30).
19. Remove transfer tube (31) from base (30) or housing (10).
20. Remove two packings (32) from transfer tube (31).

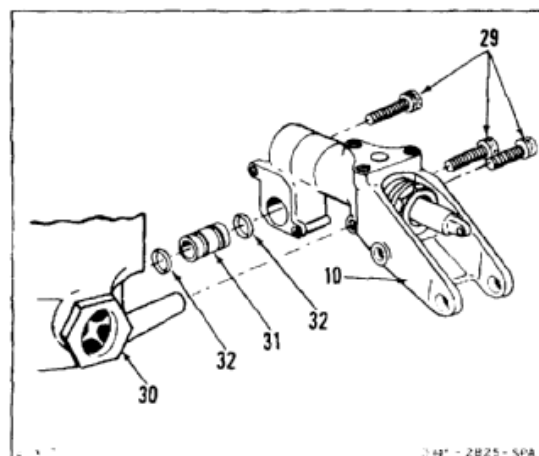

21. Install housing (10) in vise (33).
22. Remove retainer (34) from housing (10). Use **1 inch** socket and adapter.
23. Remove excluder (35) and packing (36) from retainer (34).
- 23.1. Inspect excluder (35). There shall be no cuts or tears.

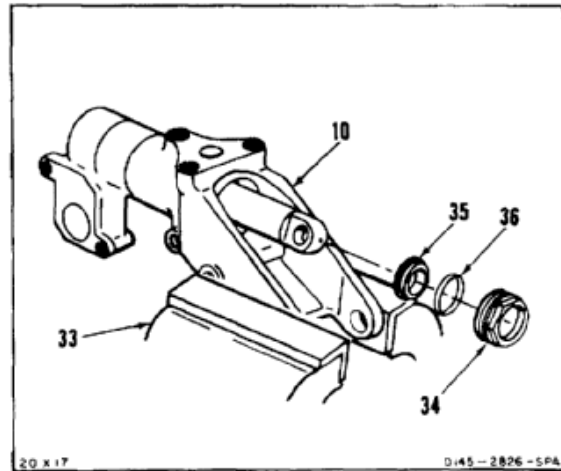

24. Pull and remove piston (37) from housing (10).
25. Remove gland (38) from piston (37).
- 25.1. Measure inside diameter of gland (38). Diameter shall not be more than **0.688 inch**. Measured surface shall have no nicks or scratches.
26. Remove two packings (39 and 40) from gland (38).
27. Measure inside diameter of bushing (41). Diameter shall not be more than **0.253 inch**.
- 27.1. Measure diameter of piston (37) at two places (41.1 and 41.2). Small diameter shall not be less than **0.683 inch**. Large diameter shall not be less than **0.964 inch**. Measured surfaces shall have no nicks or scratches.
28. Remove housing (10) from vise (33).

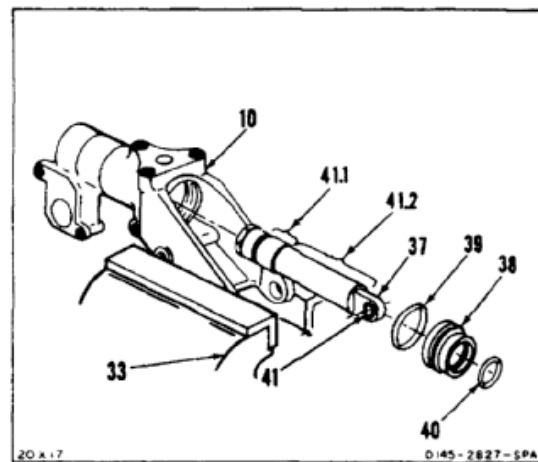

29. Remove packing (42) from piston (37).
30. Install lug of piston (37) in vise (33).
31. Remove seat (43), ball (44), and spring (45) from piston (37).
- 31.1. Inspect ball (44) and mating surface of seat (43). There shall be no nicks, scratches, or other visible damage.
32. Remove packing (46) from seat (43).
33. Remove piston (37) from vise (33).

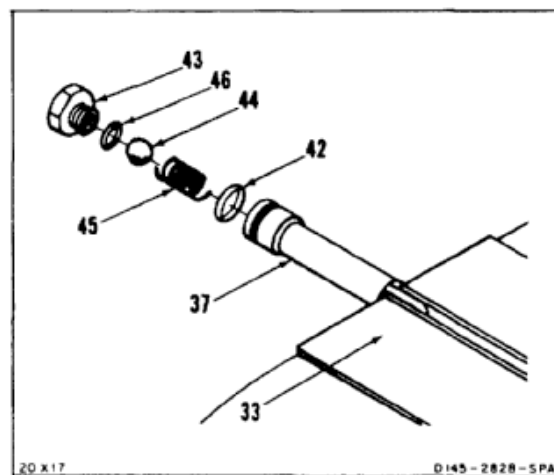

34. Install housing (10) in vise (33).
35. Remove plug (47) from housing (10).
36. Remove packing (48) from plug (47).
37. Remove seat (49), ball (50), and spring (51) from housing (10).
- 37.1. Inspect ball (50) and mating surface of seat (49). There shall be no nicks, scratches, or other visible damage.
38. Remove packing (52) from seat (49).
39. Remove housing (10) from vise (33).

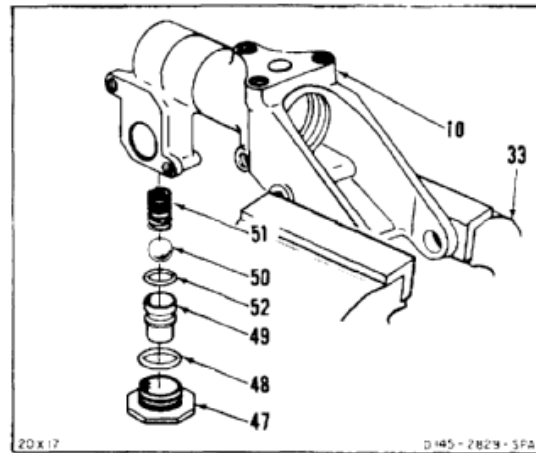

DISASSEMBLE RESERVOIR

40. Close cover (53). Remove two springs (54).
41. Open cover (53). Remove packing (55) from cover.
42. Remove ring (56) and filter (57) from housing (58). Use retaining ring pliers. Check that filter has no holes or tears.
43. Remove four screws (59) from reservoir barrel (60). Use **7/64 inch** socket key.
44. Remove housing (58) and cover (53) from barrel (60).
45. Remove packing (61) from housing (58).

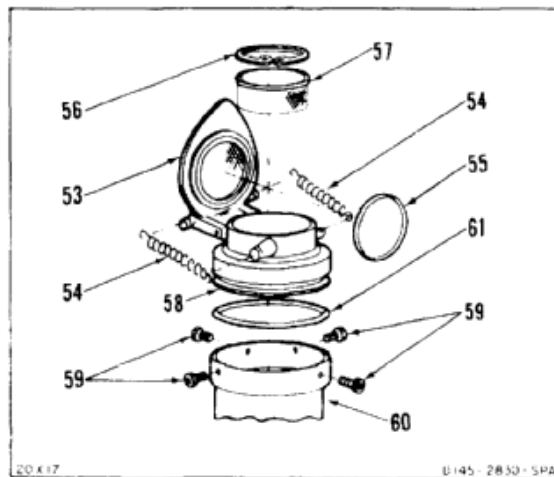

46. Remove four screws (62) and retainers (63) from base (64).
47. Remove barrel (60) and packing (65) from base (64).
48. Remove sight plug (66) from base (64).
49. Remove packing (67) from plug (66).

FOLLOW-ON MAINTENANCE:

None

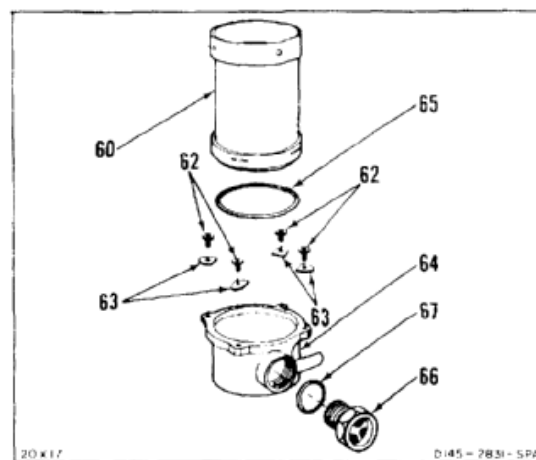

END OF TASK

INITIAL SETUP

Applicable Configurations:

All

Tools:

Hydraulic Repairer's Tool Kit, NSN 5180-00-323-4891
 Socket, 1 Inch
 Socket Key, 7/64 Inch
 Soft Jawed Vise
 Retaining Ring Pliers
 Adapter, 3/8 to 1/2 Inch

Materials:

Cloth (E120)
 Petrolatum (E274)
 Lockwire (E230)
 Lockwire (E227)

Parts:

Preformed Packings
 Excluder
 Cotter Pins
 Washer

Personnel Required:

Machinist
 Aircraft Pneudraulics Repairer
 Inspector

References:

TM 55-1520-240-23P
 Task 7-20

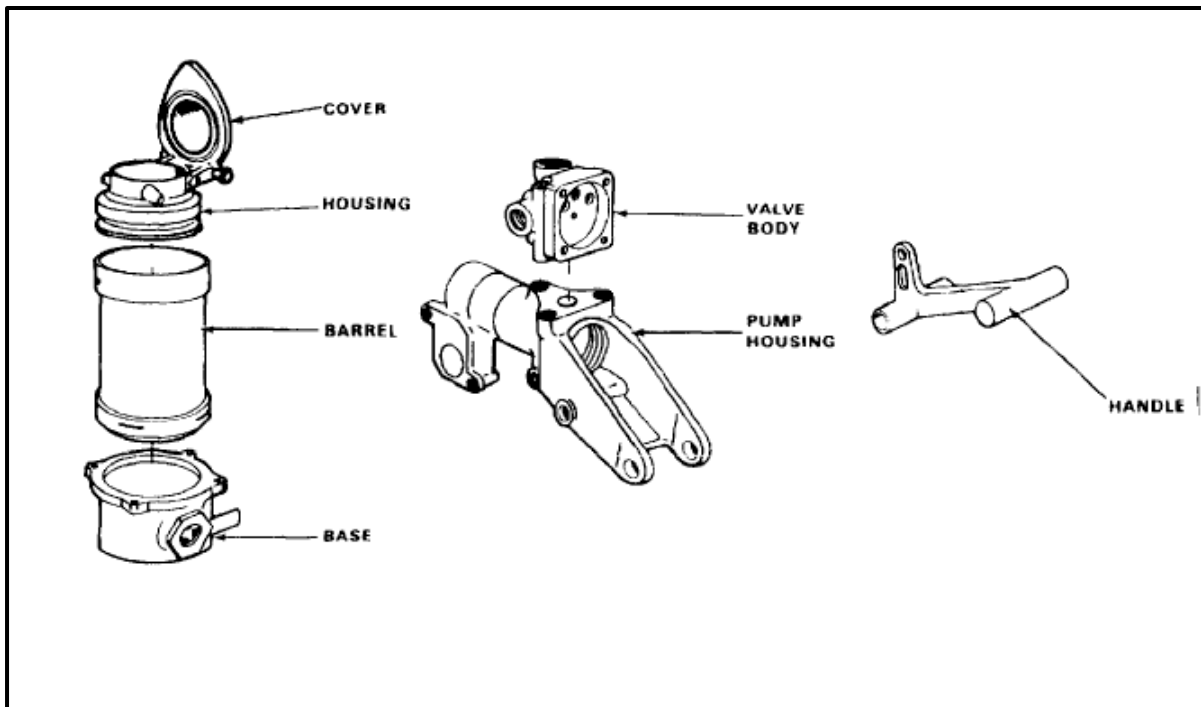

ASSEMBLE RESERVOIR

1. Install packing (1) on sight plug (2).
2. Install plug (2) in base (3).
3. Install packing (4) in base (3).
4. Position barrel (5) on base (3). Align slots (6) in barrel with thread holes (7) in base.
5. Install four retainers (8) and screws (9). Screws are self-locking. If screws turn freely, replace screws.

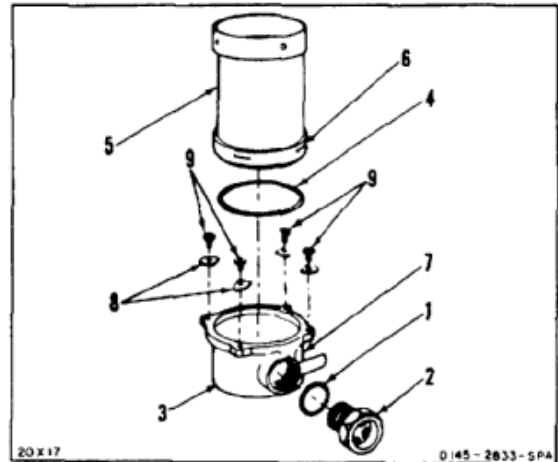

6. Install packing (10) in housing (11).
7. Position housing (11) on barrel (5). Align housing with cover (12) opening **90°** to sight plug (2) as shown.
8. Install four screws (13) in barrel (5). Use **7/64 inch** socket key.
9. Close cover (12). Install two springs (14).
10. Open cover (12). Install filter (15) and ring (16) in housing (11).
11. Install packing (17) in cover (12).

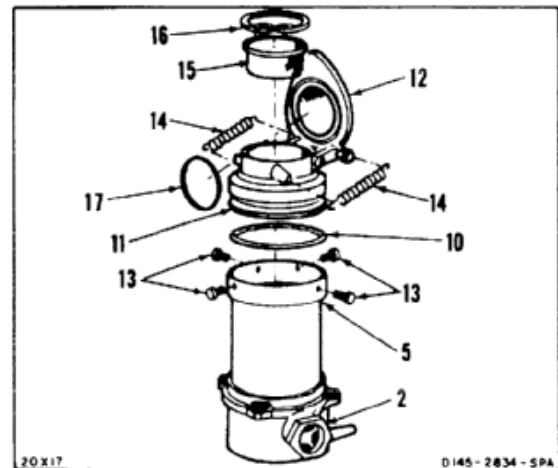

ASSEMBLE PUMP

12. Install packing (18) on seat (19).
13. Install spring (20), ball (21), and seat (19) in housing (22).
14. Install packing (23) on plug (24).
15. Install plug (24) in housing (22).

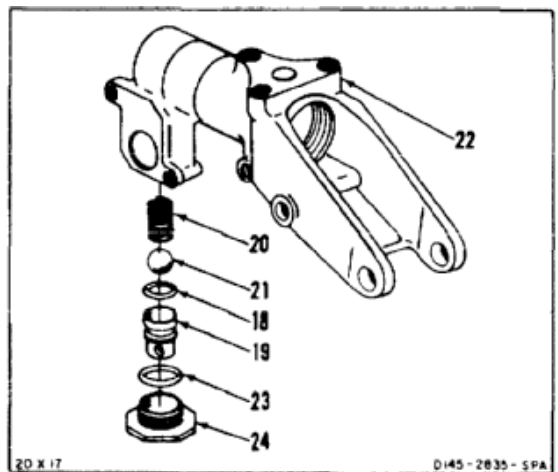

16. Install lug of piston (26) in vise (27).
17. Install packing (28) on piston (26). Install packing (29) on seat (30).
18. Install spring (31), ball (32), and seat (30) in piston (26). If retainer turns freely, have machinist replace locking insert (33).
19. Remove piston (26) from vise (27).

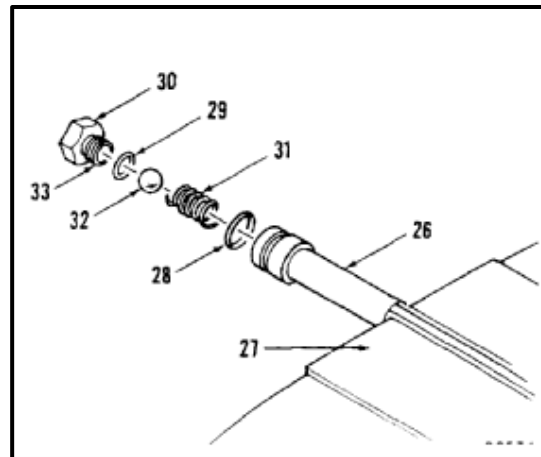

20. Install housing (22) in vise (27). Install bushing (34) in lug of piston (26).
21. Install two packings (35 and 36) on gland (37).
22. Slide gland (37) on piston (26), with large end of gland to piston.
23. Install piston (26) and gland (37) in housing (22) until gland is inside housing.

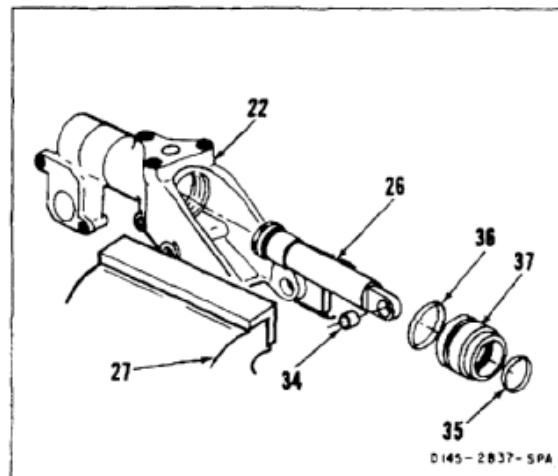

24. Install packing (38) on excluder (39).
25. Wipe piston (26) dry of hydraulic fluid outboard of gland (37). Use cloth (E120).
26. Coat inside diameter of excluder (39) with petrolatum (E274).
27. Install excluder (39) in retainer (40), with coned end of excluder to retainer.
28. Install retainer (40) in housing (22). Use 1 inch socket. If retainer turns freely, have machinist replace locking insert (41). Remove housing (22) from vise (27).

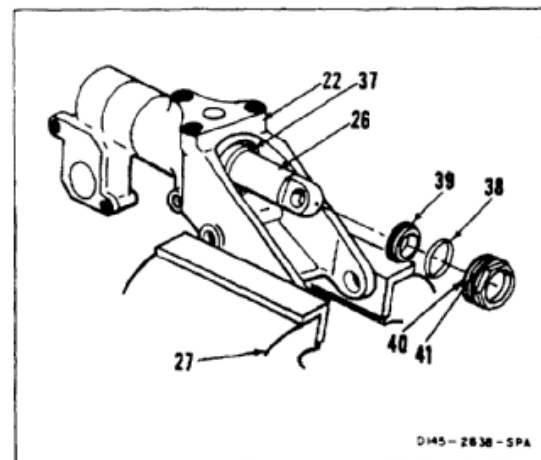

29. Install two packings (42) on transfer tube (43).
30. Install transfer tube (43) in base (3).
31. Position housing (22) over transfer tube (43).
32. Install two screws (44).
33. Lockwire two screws (44) to plug (24). Use lockwire (E230).
34. Install screw (45).
35. Lockwire screw (45) to gage (2). Use lockwire (E230).

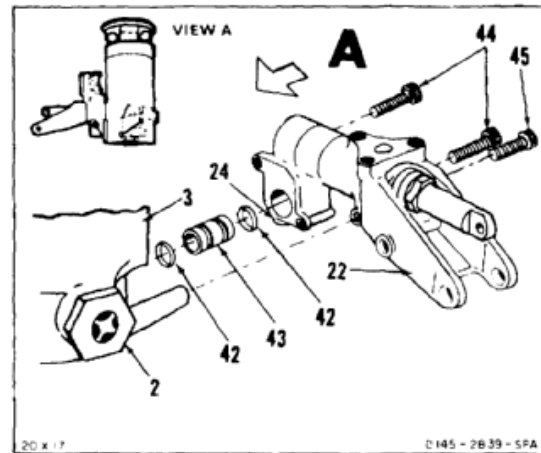

ASSEMBLE SELECTOR VALVE

36. Install three packings (46) on seals (47).

NOTE

Correct number of shims is determined during testing (Task 7-20).

37. Install shims (47.1), three springs (48) and seals (47) in valve (49), with thin lip of seals outboard.

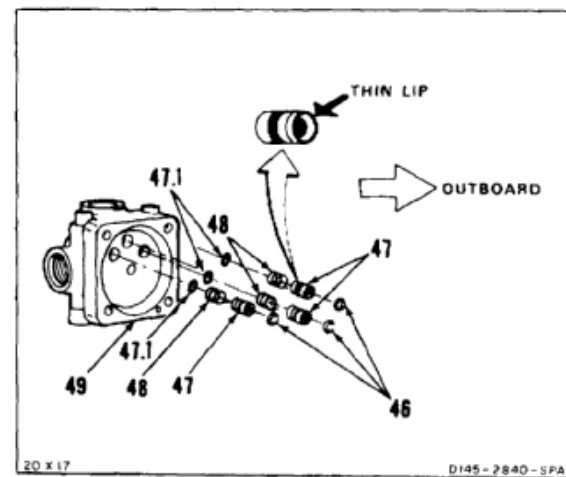

38. Install packing (50) on cover (51).
39. Install washer (52) and packing (53) on rotor (54).
40. Install rotor (54) in cover (51). Align hole (55) in rotor with slot (56) in cover.

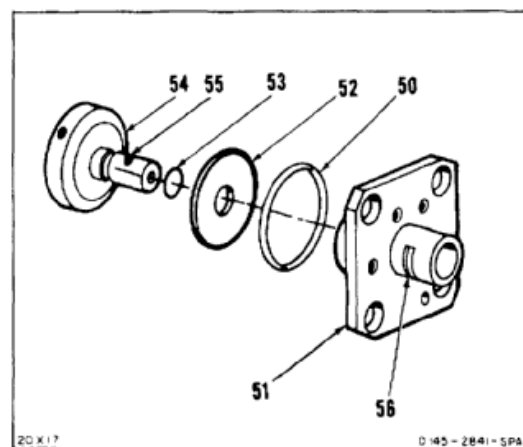

41. Install cover (51) in valve (49), with slot (56) facing valve side (57).
42. Install four screws (58). Screws are self-locking. If screws turn freely, replace screws.

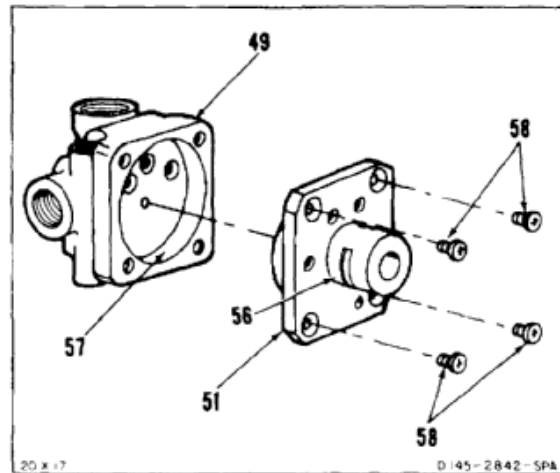

NOTE

Correct number of shims is determined during testing (Task 7-20).

43. Install shims (58.1), spring (59) and ball (60) in handle (61).
44. Slide handle (61) on shaft (62). Align holes (63) in handle with hole in slot (56). Press handle towards valve (49) to expose hole in slot.
45. Install screw (64) in handle (61).
46. Lockwire screw (64) to handle (61). Use lockwire (E227).

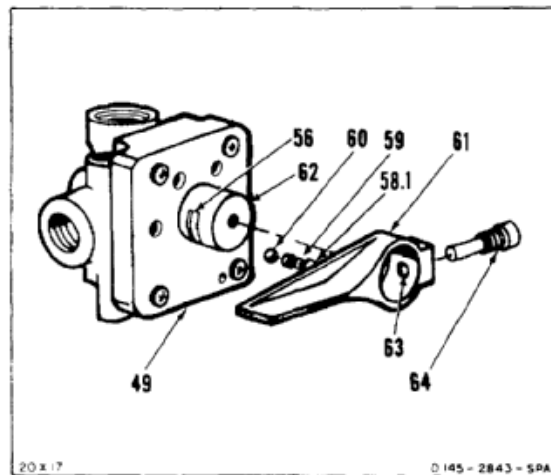

47. Install two packings (65) on transfer tube (66).
48. Install housing (22) in vise (27). Install transfer tube (66) in housing (22).
49. Slide valve (49) over transfer tube (66).
50. Install two screws (67) and screw (68).
51. Lockwire two screws (67). Use lockwire (E230).
52. Lockwire screw (68) to valve (49). Use lockwire (E230). Remove housing (22) from vise (27).

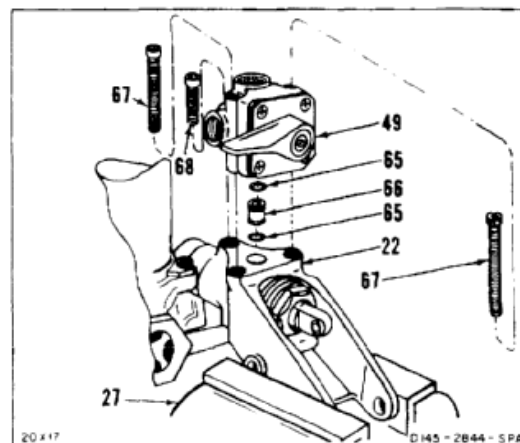

ASSEMBLE HANDLE

53. Install three bushings (69) in handle (70).
54. Position handle (70) in housing (22). Install sleeve (71) through housing and handle.
55. Install bolt (72) and nut (73). Tighten nut finger-tight.
56. Position two links (74) on piston (26). Install bolt (75) and nut (76). Turn piston to install bolt. Tighten nut finger-tight.
57. Position handle (70) between link (74). Install bolt (77) and nut (78). Tighten nut finger-tight.

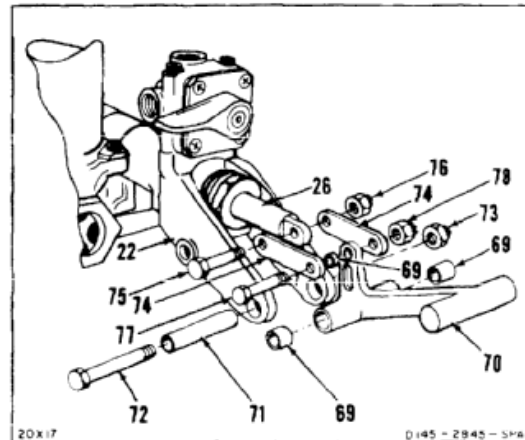

58. Back off nuts (73, 76 and 78), and align nearest nut slot and bolt hole. Install cotter pins (79, 80 and 81).
59. Check handle (70). Handle shall be free to move.

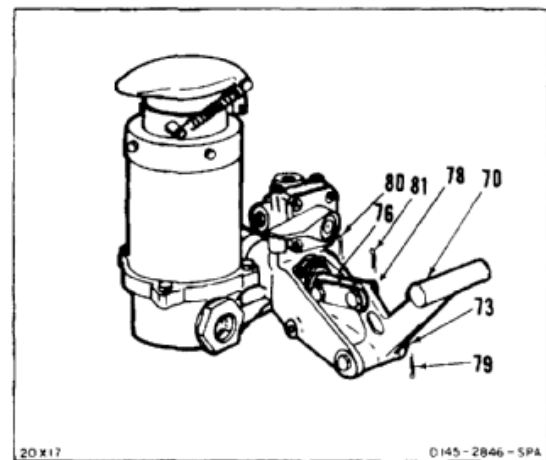
INSPECT**FOLLOW-ON MAINTENANCE:**

Test fill module (Task 7-20).

END OF TASK

INITIAL SETUP

Applicable Configurations:

All

Tools:

- Hydraulic Repairer's Tool Kit, NSN 5180-00-323-4891
- Container, 2 Quart
- Vise
- Hose, 1/4 Inch, 0 psi
- Hydraulic Test Stand
- Support Fixture (APP E-31)
- Stopwatch
- Graduate, 10 cc (2)
- Graduate, 500 cc
- Dial Indicating Scale, 0 to 50 Pounds
- Relief Valve
- Shutoff Valve (5)
- Restrictor Valve (2)
- Gage, 500 psi (2)
- Tube, 1/4 Inch, 0 to 500 psi
- Bleed Fitting, 1/4 Inch

Materials:

- Hydraulic Fluid (E199)
- Cloths (E120)
- Gloves (E186)

Personnel Required:

- Aircraft Pneudraulics Repairer
- Inspector

References:

- Task 7-19

Equipment Condition:

- Off Helicopter Task
- Fill Module Installed In Crashproof Box
- Test Setup

General Safety Instructions:

WARNING

Use suitable crashproof box to shield personnel and equipment in case of failure during test.

WARNING

Hydraulic fluid (E199) is toxic. It can irritate skin and cause burns. Avoid inhaling. Use only with adequate ventilation. Avoid contact with skin, eyes, or clothing. In case of contact, immediately flush skin or eyes with water for at least **15 minutes**. Get medical attention for eyes.

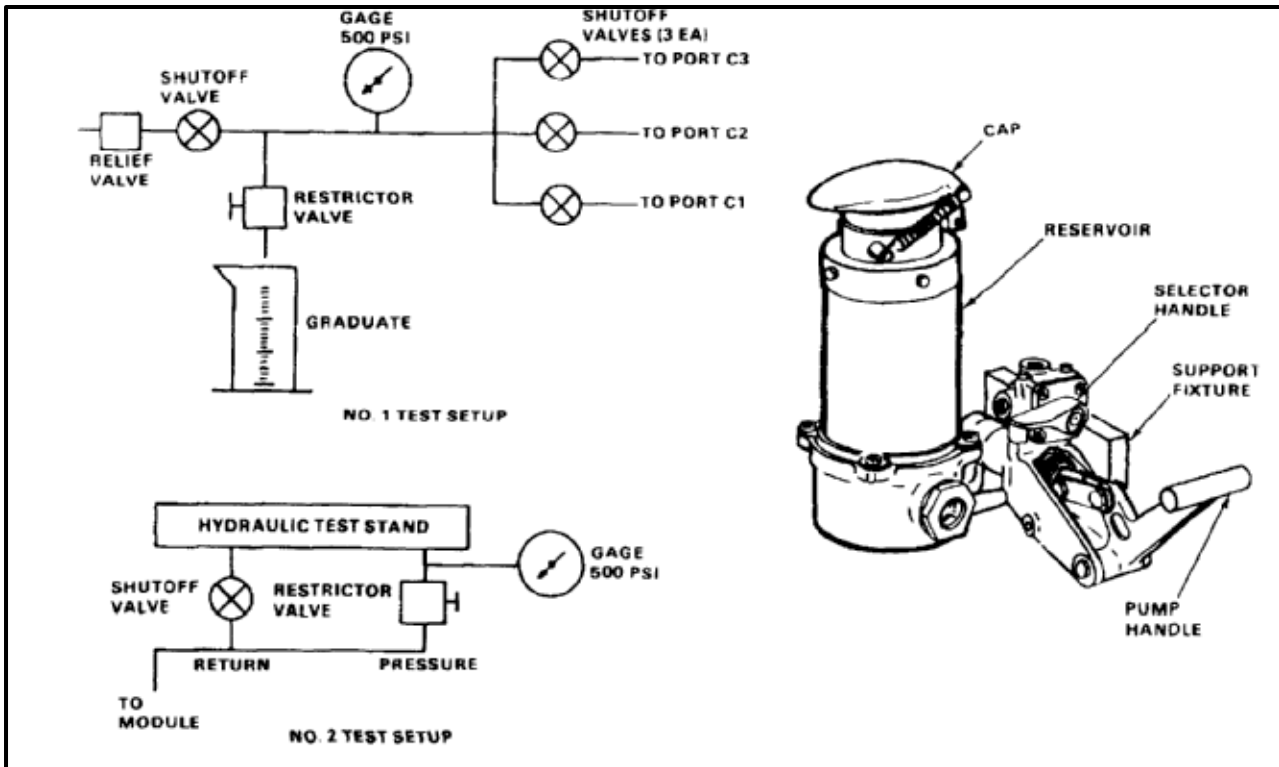

INTEGRITY PRESSURE AND EXTERNAL LEAKAGE TEST

1. Clamp support fixture (1) in vise (2).
2. Position module (3) on fixture (1). Install three washers (4), three bolts (5), and one nut (6).
3. Open cap (7) and fill reservoir (8) with hydraulic fluid (E199). Close cap. Wear gloves (E186).
4. Set valve handle (9) to position 1. Install bleed fitting (10) in port C1 (11).
5. Connect hose (12) to fitting (10). Insert end of hose in container (13) of fluid (E199).
6. Operate pump handle (14) until flow from hose (12) is air free.
7. Repeat steps 4 thru 6 with handle (9) at position 2, then 3, and fitting (10) installed in port C2 (15), then port C3 (16), respectively.
8. Remove hose (12) and fitting (10).
9. Open cap (7) and fill reservoir (8) with hydraulic fluid (E199). Close cap.

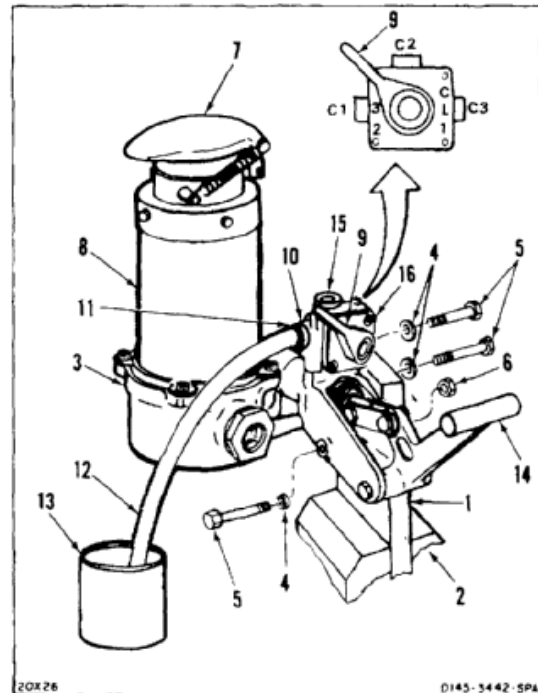

10. Connect No. 1 test setup to module (3). Connect valve (17) to port C1 (11), valve (18) to port C2 (15), and valve (19) to port C3 (16).
11. Set handle (9) to position 1.
12. Close valves (18, 19, 20, and 21). Open valve (17).
13. Operate handle (14) until gage (22) indicates **300 to 330 psi**. Maintain pressure for **2 minutes**.
14. Check for external leaks. Leaks shall not exceed **1 drop**.
15. Release pressure. Open valve (21). Collect spilled fluid in container (13).
16. Repeat steps 11 thru 15, setting handle (9) to position 2, and closing valves (17 and 21) and opening valve (18).
17. Repeat steps 11 thru 15, setting handle (9) to position 3, and closing valves (18 and 21), and opening valve (19).

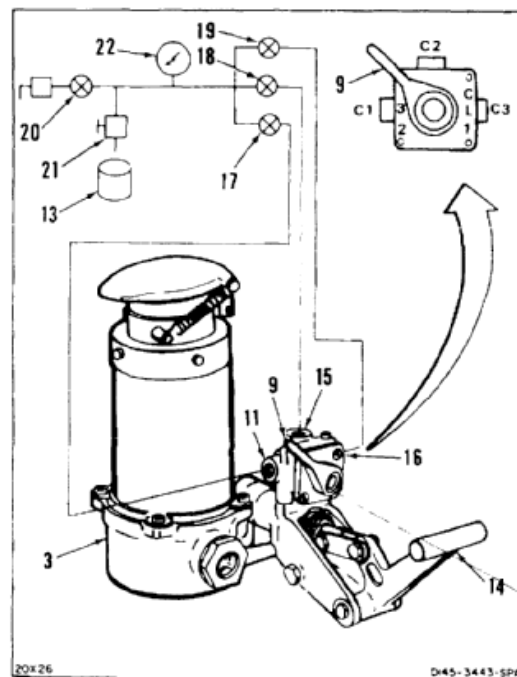

PUMP SHAFT LEAKAGE TEST

18. Fill reservoir (8) with fluid (E199).
19. Close valves (19 and 21). Open valves (17 and 20).
20. Set handle (9) to position 1.
21. Set relief valve (23) to open at **200 psi**.

NOTE

For **one stroke** move handle fully in and out.

22. Operate handle (14) for **25 strokes**. Collect spilled fluid in container (13).
23. Check shaft seal (24) for leaks. Leaks shall not exceed **1 drop**.

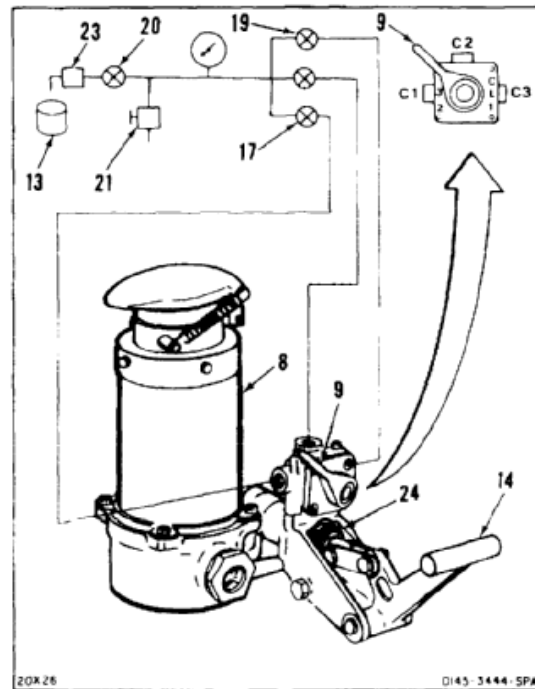

PUMP OUTPUT TEST

24. Close valve (20). Open valve (21).
25. Operate handle (14) until reservoir (8) is about **1/2 full**. Collect spilled fluid in graduate (25). Empty graduate. Use **500 cc** graduate.
26. Operate handle (14) **20 strokes in 24 seconds**. Collect spilled fluid in graduate (25). Fluid in graduate shall be **340 cc's** minimum.

PUMP HANDLE TORQUE TEST

27. Push handle (14) fully in. Attach scale (26) to handle.
28. Pull handle (14) with scale (26) at **90°** to handle shaft (27) through **1/2 stroke**. Scale indication shall not exceed **45 pounds**.
29. Remove scale (26).
30. Close valve (21).

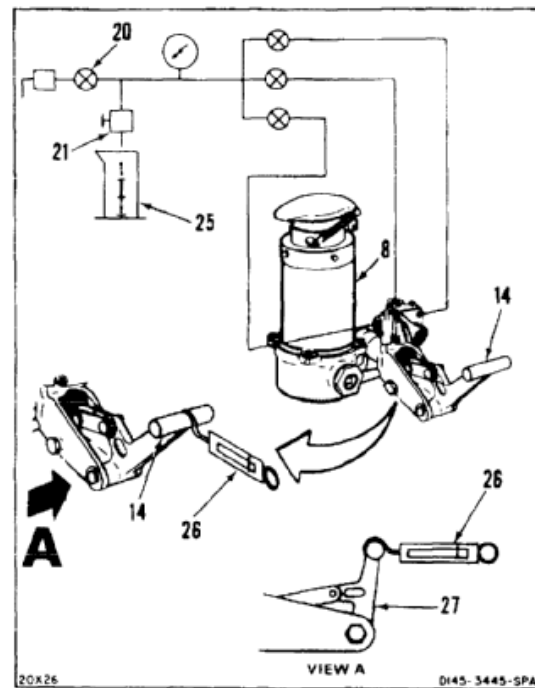

VALVE SHAFT LEAK TEST

31. Fill reservoir (8) with fluid (E199).
32. Open valves (17, 18 and 19).
33. Set handle (9) to position 1.
34. Operate handle (14) and maintain **200 psi** on gage (22). Set valve (21) for flow of **5 cc per minute**. Collect spilled fluid in graduate (28). Use **10 cc** graduate.
35. Maintain **200 psi** on gage (22). Cycle handle (9) 25 times between positions 1, 2 and 3.
36. Check for leaks at shaft seal (29). Leaks shall not exceed **1 drop**.
37. Close valve (21).

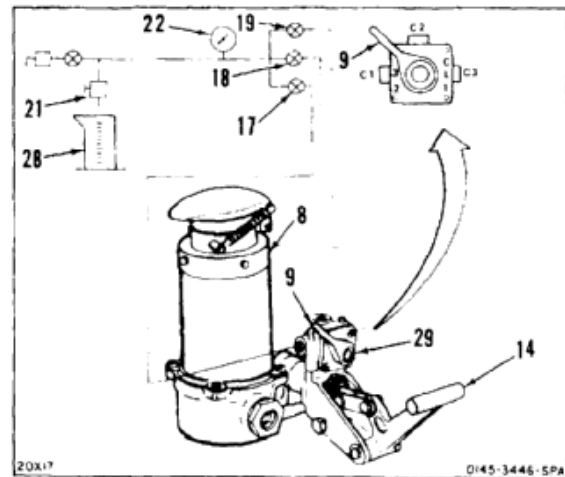
**HANDLE TORQUE TEST**

38. Set handle (9) to position 3. Attach scale (26) to end of handle.

NOTE

Torque equals L x scale indication.

39. Pull handle (9) with scale (26) at **90°** to handle as shown. Torque to start handle moving shall be **3 to 10 inch-pounds** greater than torque to keep handle moving. Add shims as needed (Task 7-19).

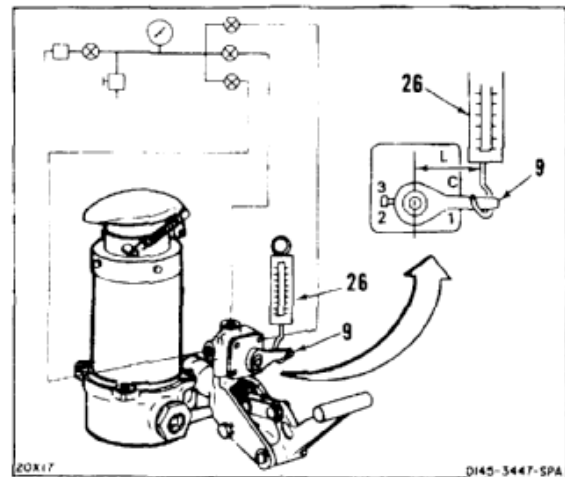

VALVE PORT LEAK TEST

40. Disconnect No. 1 test setup from ports C2 and C3 (15 and 16).
41. Close valves (18, 19, and 21).
42. Connect tubes (30 and 31) to ports C2 and C3 (15 and 16). Place graduates (28 and 32) at outlets of tubes. Use **10 cc** graduate.

NOTE

Keep tubes as short as possible.

43. Set handle (9) to position 1.
44. Operate handle (14) and maintain **200 psi** on gage (22) for **5 minutes**.
45. Check for leaks at ports C2 and C3 (15 and 16). Leaks shall not exceed **2 cc's per minute**.
46. Repeat steps 42 thru 45, connecting No. 1 test setup to port C2 (15) and setting handle (9) to position 2. Check for leaks at ports C1 and C3 (11 and 16).
47. Repeat steps 42 thru 45 connecting No. 1 test setup to port C3 (16) and setting handle (9) to position 3. Check for leaks at ports C1 and C2 (11 and 15).
48. Disconnect No. 1 test setup from module (3).

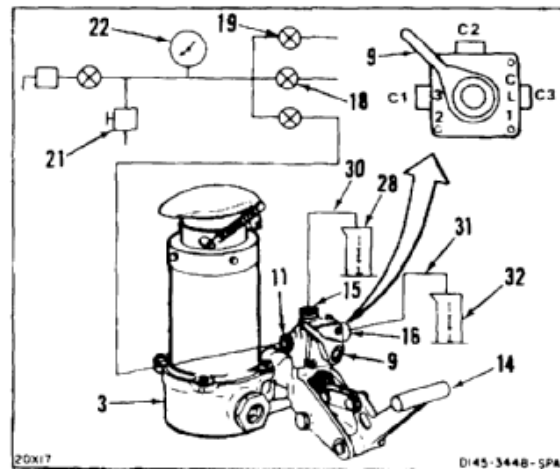

VALVE RELIEF TEST

49. Connect tube (31) to port C3 (16). Place graduate (32) at outlet of tube.
50. Connect No. 2 test setup to port C1 (11).
51. Set handle (9) to position 1.
52. Close valve (33).
53. Adjust valve (34) to apply pressure to port C1 (11). Check for leaks at ports C2 and C3 (15 and 16). At **300 to 700 psi** on gage (35), leaks shall change to steady flow. Add shims as needed (Task 7-19).
54. Close valve (34). Open valve (33).
55. Repeat steps 50 thru 54, connecting No. 2 test setup to port C2 (15), and setting handle (9) to position 2. Check for leaks at ports C1 and C3 (11 and 16).
56. Repeat steps 50 thru 54, connecting No. 2 test setup to port C3 (16), and setting handle (9) to position 3. Check for leaks at ports C1 and C3 (11 and 15).
57. Disconnect No. 2 test setup from port C3 (16).
58. Disconnect tubes (30 and 31) from ports C1 and C3 (11 and 15).
59. Remove nut (6), three bolts (5), and washers (4). Remove module (3) from support (1).
60. Remove support (1) from vise (2).

INSPECT

FOLLOW-ON MAINTENANCE:

None

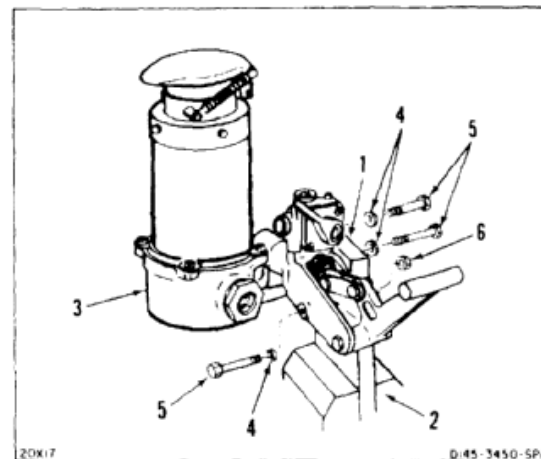
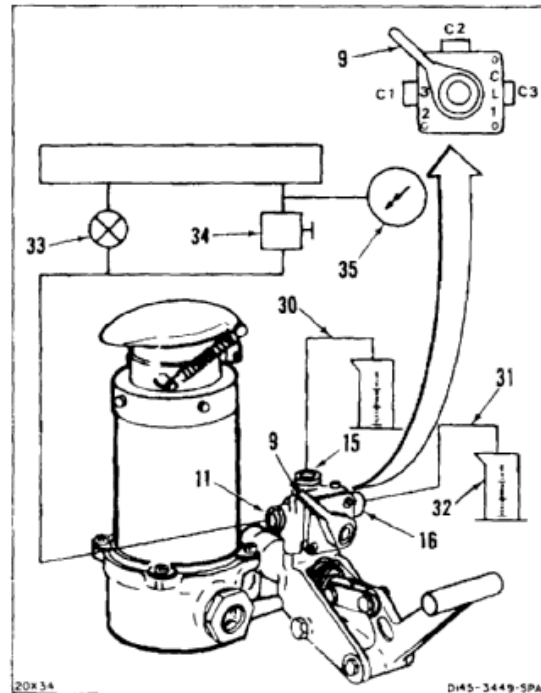

END OF TASK

INITIAL SETUP

Applicable Configurations:

All

Tools:

Aircraft Mechanic's Tool Kit, NSN 5180-00-323-4692
Torque Wrench, 30 to 150 Inch-Pounds

Materials:

Cloths (E120)

Parts:

Preformed Packings

Personnel Required:

Medium Helicopter Repairer
Inspector

References:

TM 55-1520-240-23P

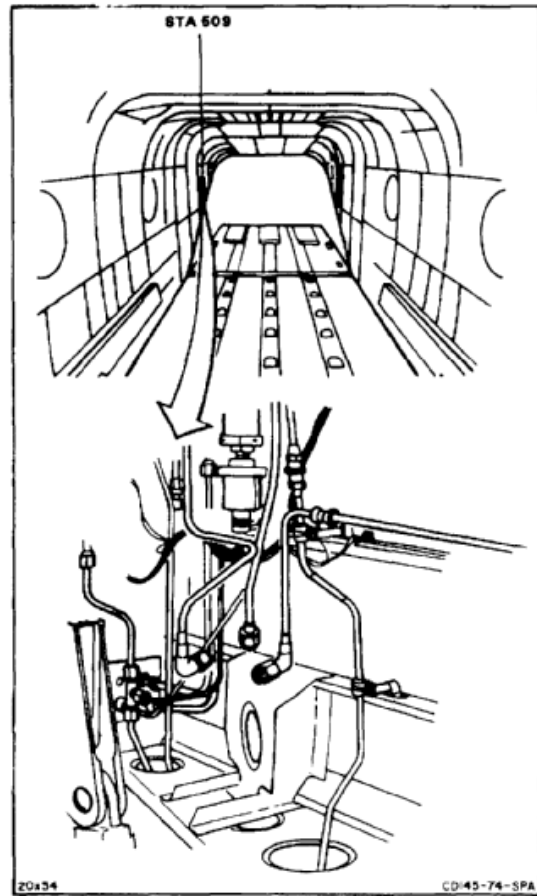

1. Install three unions (1) and packings (2) in valve ports (3).

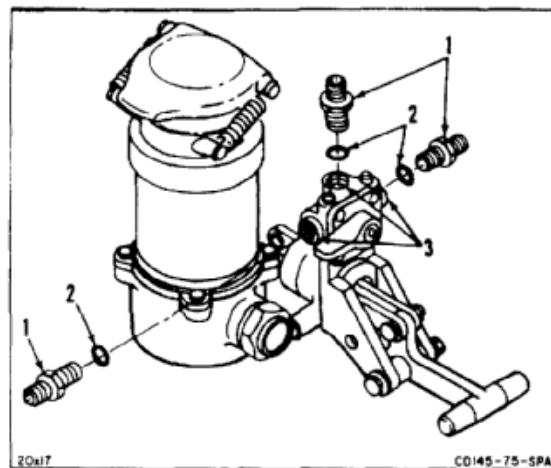

7-21 INSTALL FILL MODULE (Continued)

7-21

2. Position module (4) on bracket (5). Install bolt (6) and washer (7) through pump (8).
3. Install two bolts (9) and washers (10) through bracket (5).
4. Torque bolts (6 and 9) to **40 inch-pounds**.

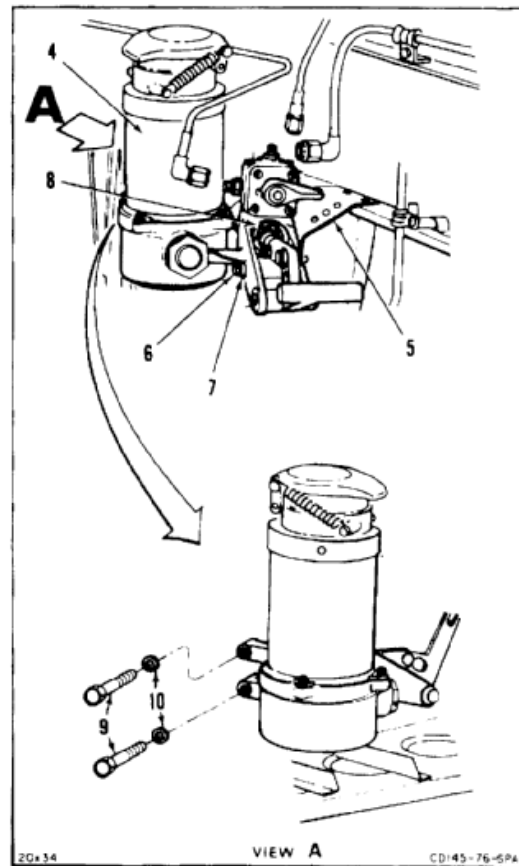

5. Connect three tubes (11) to unions (2). Use cloths (E120) for spilled fluids.
6. Tighten nuts (12).

INSPECT

7. Install screw (13) in two clamps (14).
8. Rotate valve handle (15) clockwise back to FILL position.

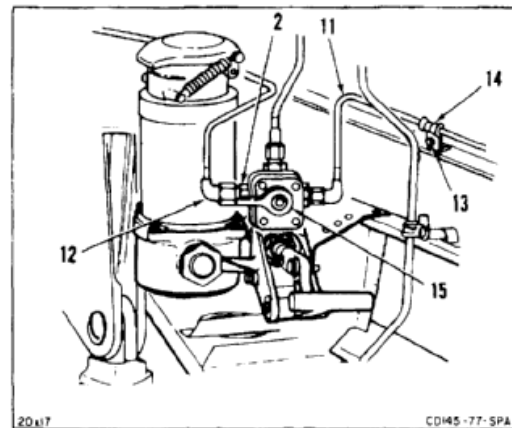
**FOLLOW-ON MAINTENANCE:**

- Bleed flight control hydraulic system (Task 7-16).
- Perform operational check of utility hydraulic system (TM 55-1520-240-T).
- Perform operational check of flight control hydraulic system (TM 55-1520-240-T).
- Close cargo ramp (TM 55-1520-240-T).

END OF TASK

INITIAL SETUP

Applicable Configurations:

All

Tools:

Aircraft Mechanic's Tool Kit, NSN 5180-00-323-4692
 Open-End Wrench, 1 Inch
 Open-End Wrench, 1-1/4 Inch
 Container, 2 Quart
 Fluorescent Penetrant Method

Materials:

Cloths (E120)
 Paper Tags (E264)
 Tape (E388)
 Barrier Material (E81)
 Gloves (E184.1)
 Dry Cleaning Solvent (E162)

Personnel Required:

Medium Helicopter Repairer

Reference:

TM 1-1520-253-23

Equipment Condition:

Battery Disconnected (Task 1-39)
 Electrical Power Off
 Hydraulic Power Off
 Forward Transmission Drip Pan Removed (Task 2-3)
 Power Drain No. 1 Flight Control Hydraulic System Reservoir (Task 1-60.1)
 Manual Drain Flight Control Hydraulic System Reservoir (Task 7-113)

General Safety Instructions:**WARNING**

Hydraulic fluid (E199) is toxic. It can irritate skin and cause burns. Avoid inhaling. Use only with adequate ventilation. Avoid contact with skin, eyes, or clothing. In case of contact, immediately flush skin or eyes with water for at least **15 minutes**. Get medical attention for eyes.

WARNING

Hydraulic fluid ejected under pressure can cause injury to personnel. Hydraulic fluid sprayed into the air is a fire hazard.

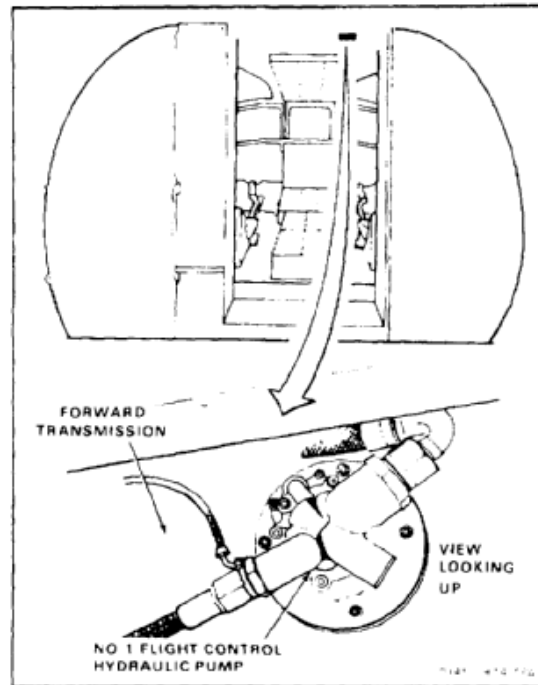

NOTE

If a crack in the hydraulic pump casing is suspected during removal, refer to TM 1-1520-253-23.

1. Tag and disconnect four hydraulic hoses (1) from pump (2). Use container and cloths (E120) for spilled fluid. Wear gloves (E184.1).
2. Remove four nuts (3) from studs (4).
3. Remove pump (2).
- 3.1. Cover pump mount on transmission with barrier material (E81) or equivalent.

WARNING

Dry cleaning solvent (E162) is flammable and toxic. It can irritate skin and cause burns. Use only in well-ventilated area, away from heat and open flame. In case of contact, immediately flush skin or eyes with water for at least **15 minutes**. Get medical attention for eyes.

NOTE

When removing a Stratopower/ Dynapower pump there is a metal shim bonded to pump flange. If this shim comes unbonded from the pump flange. It does not have to be rebonded for installation.

- 3.2. Remove gasket (5.1) from pump (2).
- 3.3. Wipe grease off splines (5). Use cloths (E120) with dry cleaning solvent (E162). Wear gloves (E184.1).
4. Protect spline (5) with barrier material (E81) and tape (E388).

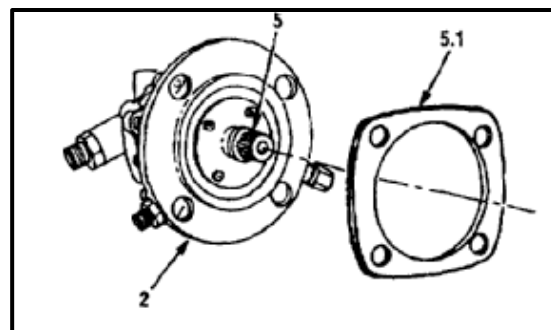
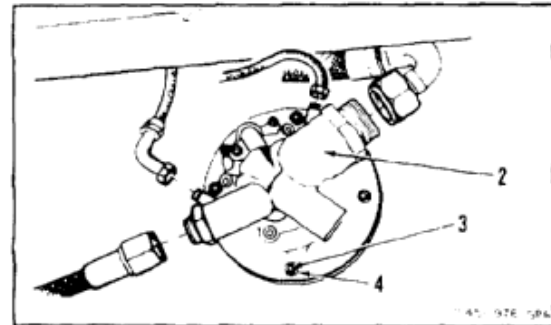
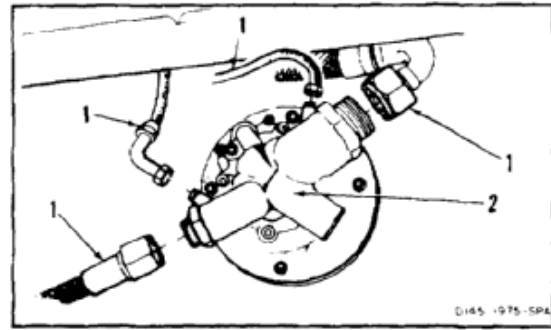

5. Remove union (6) and packing (7) from pump (2).
6. Remove union (8) and packing (9).
7. Remove union (10) and packing (11).
8. Remove union (12) and packing (13) from case drain port (14).
9. Cover pump (2) mount on transmission with barrier material (E81) or equivalent.

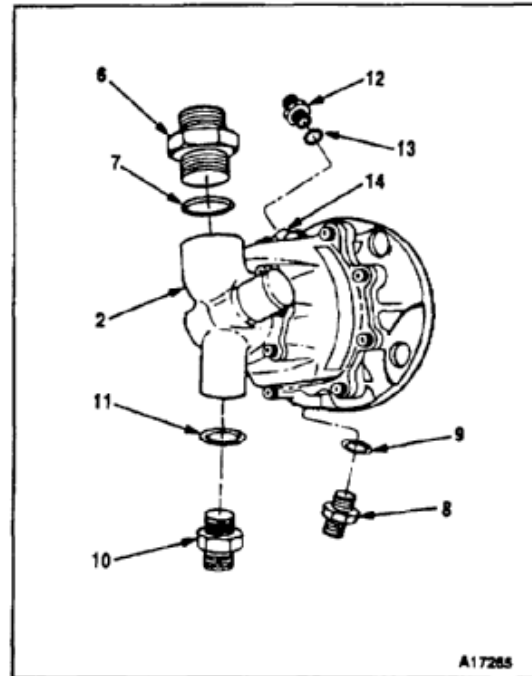
**FOLLOW-ON MAINTENANCE:**

None

END OF TASK

7-156

INITIAL SETUP**Applicable Configurations:**

All

Tools:

Aircraft Mechanic's Tool Kit, NSN 5180-00-323-4692
 Open-End Wrench, 1 Inch
 Open-End Wrench, 1-1/4 Inch
 Container, 2 Quart
 Fluorescent Penetrant Method

Materials:

Cloths (E120)
 Paper Tags (E264)
 Barrier Material (E81)
 Gloves (E184.1)
 Dry Cleaning Solvent (E162)
 Tape (E388)
 Tags (E264)

Personnel Required:

Medium Helicopter Repairer

Reference:

TM 1-1520-253-23

Equipment Condition:

Battery Disconnected (Task 1-39)
 Electrical Power Off
 Hydraulic Power Off
 Cargo Ramp Open and Level (TM 55-1520-240-T)
 Left Transmission Access Door Open (Task 2-2)
 Power Drain No. 2 Flight Control Hydraulic System
 Reservoir (Task 1-61.1)
 Manually Drain Flight Control Hydraulic System
 Reservoir (Task 7-113)

General Safety Instructions:**WARNING**

Hydraulic fluid (E199) is toxic. It can irritate skin and cause burns. Avoid inhaling. Use only with adequate ventilation. Avoid contact with skin, eyes, or clothing. In case of contact, immediately flush skin or eyes with water for at least **15 minutes**. Get medical attention for eyes.

WARNING

Hydraulic fluid ejected under pressure can cause injury to personnel.

Hydraulic fluid sprayed into the air is a fire hazard.

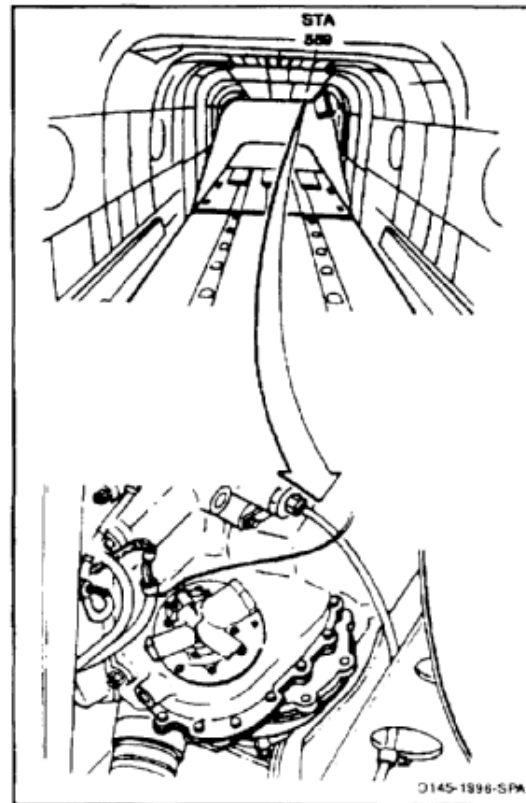

NOTE

If a crack in the hydraulic pump casing is suspected during removal, refer to TM 1-1520-253-23.

1. Tag and disconnect four hydraulic hoses (1) from pump (2). Use tag (E264). Use container and cloths (E120) for spilled fluid. Wear gloves (E184.1).
2. Remove four nuts (4) from studs (5).
3. Remove pump (2).
4. Cover pump mount on transmission with barrier material (E81) or equivalent.

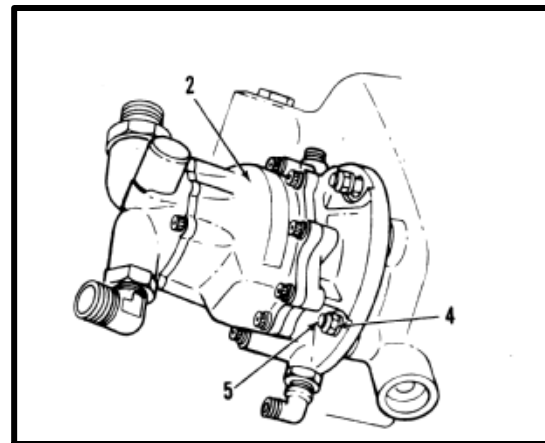
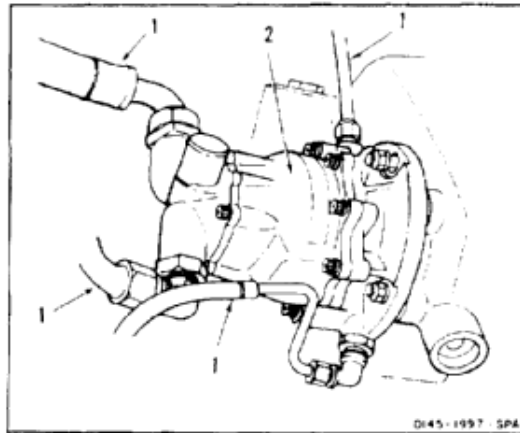
**WARNING**

Dry cleaning solvent (E162) is flammable and toxic. It can irritate skin and cause burns. Use only in well-ventilated area, away from heat and open flame. In case of contact, immediately flush skin or eyes with water for at least **15 minutes**. Get medical attention for eyes.

5. Remove gasket (5.1) from pump (2).
- 5.1. Wipe grease off splines (5). Use cloths (E120) with dry cleaning solvent (E162). Wear gloves (E184.1).
- 5.2. Protect spline (5) with barrier material (E81) and tape (E388).

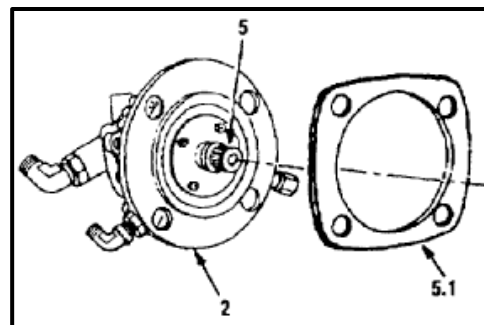

7-23 REMOVE NO. 2 FLIGHT CONTROL HYDRAULIC PUMP (Continued)

7-23

6. Remove union (5) and packing (6) from pump (2).
7. Tag and note position of elbow (7). Loosen nut (8). Remove elbow and packing (9).
8. Tag and note position of elbow (10). Loosen nut (11). Remove elbow and packing (12).
9. Remove union (13) and packing (14) from case drain port (15).
10. Cover pump (2) mount on transmission with barrier material (E81) or equivalent.

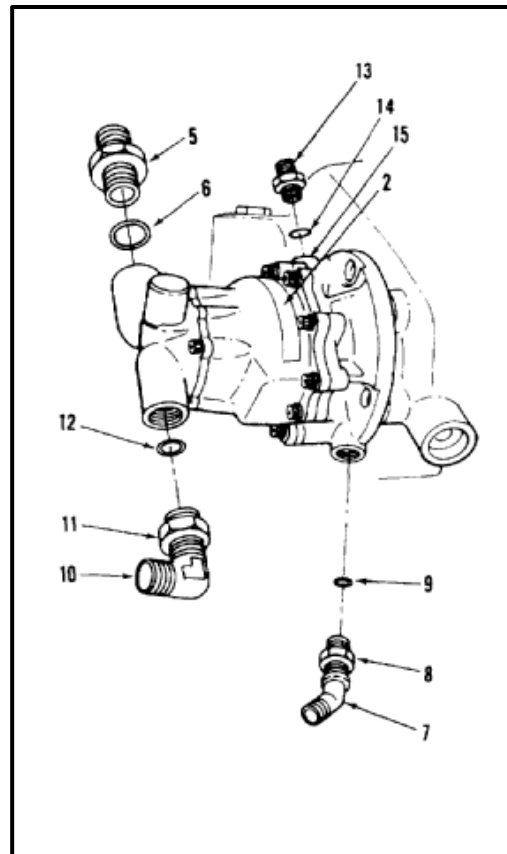
**FOLLOW-ON MAINTENANCE:**

None

END OF TASK

INITIAL SETUP

Applicable Configurations:

All

Tools:

Hydraulic Repairer's Tool Kit, NSN 5180-00-323-4891
 Socket Key, 9/64 Inch

Materials:

None

Personnel Required:

Aircraft Pneudraulics Repairer
 Inspector

Equipment Condition:

Off Helicopter Task

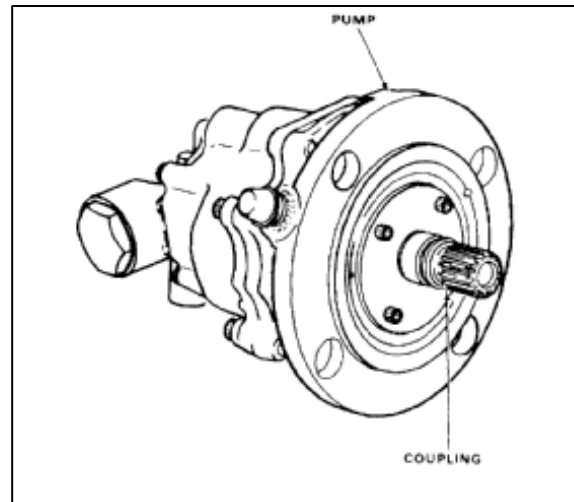

NOTE

General inspection criteria (Task 7-1.1) for obvious damage applies unless otherwise stated.

Inspection steps cover parts that are subject to wear.

1. Remove screw (1) from coupling (2).

2. Remove coupling (2) from pump (3).
3. Remove sleeve (4) and packing (5) from coupling (2).
- 3.1. Inspect splines of coupling (2). There shall be no cracked or chipped splines.

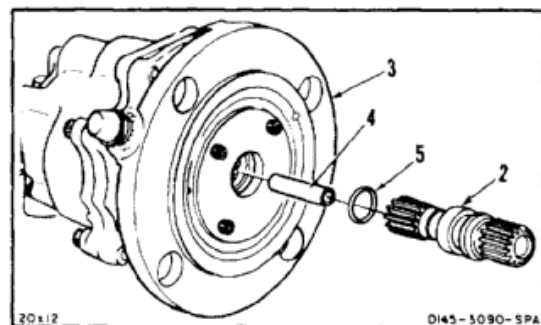
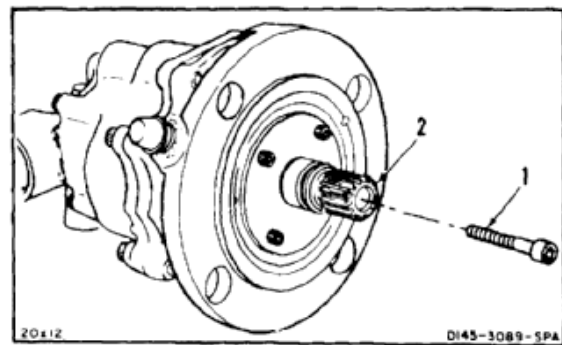

7-24 REMOVE AND INSPECT HYDRAULIC PUMP COUPLING AND SEAL (AVIM) (Continued)

7-24

4. Remove four screws (6) and washers (7) from pump (3). Use **9/64 inch** socket key.
5. Remove retainer (8) from pump (3).

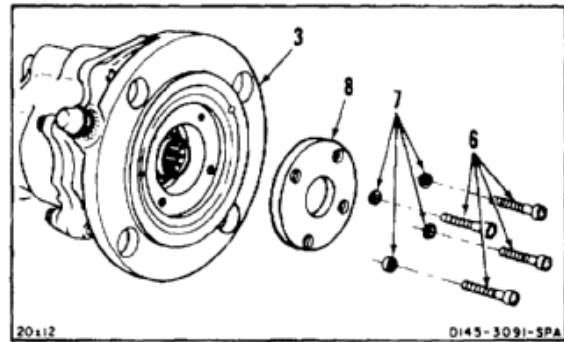

6. Remove ring (9) from pump (3). Use two screws (6) as shown.
7. Remove packing (10) from ring (9).

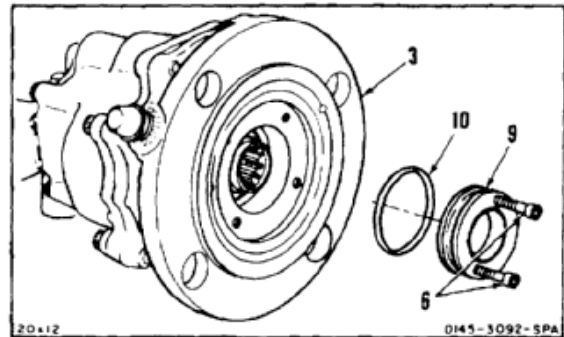

8. Remove seal (11), grommet (12), spring (13), ring (14), and spring (15) from pump (3).

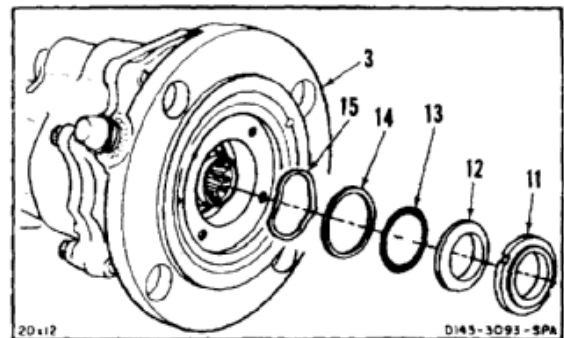

9. Remove retainer (16) from pump (3). Use point of scribe tool (17) in slots (18) to release retainer.

FOLLOW-ON MAINTENANCE:

None

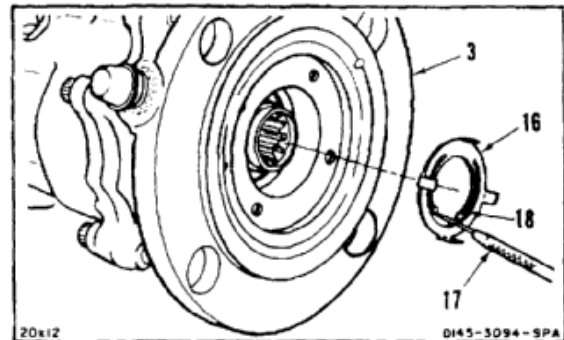

END OF TASK

INITIAL SETUP

Applicable Configurations:

All

Tools:

Hydraulic Repairer's Tool Kit, NSN 5180-00-323-4891
 Socket Key, 9/64 Inch

Materials:

Grease (E190)

Parts:

Preformed Packing
 Seal

Personnel Required:

Aircraft Pneudraulics Repairer
 Inspector

References:

TM 55-1520-240-23P

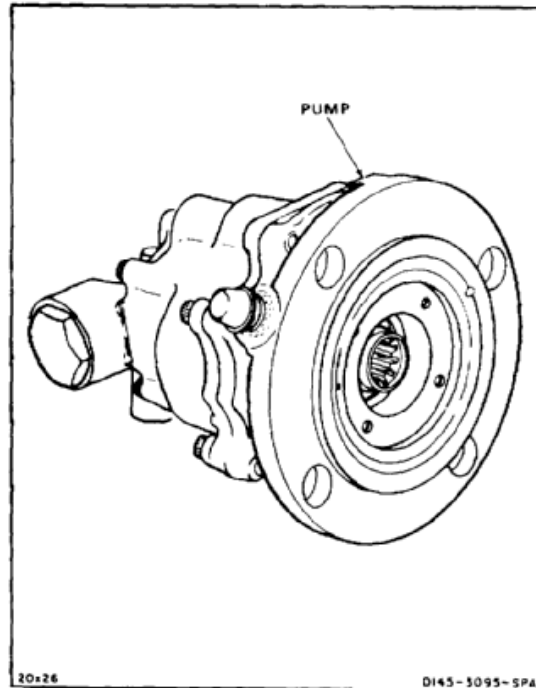

1. Install retainer (1) on shaft (2), of pump (3), with tangs (4) outward. Slide retainer until clips (5) of retainer engage with slot in shaft.

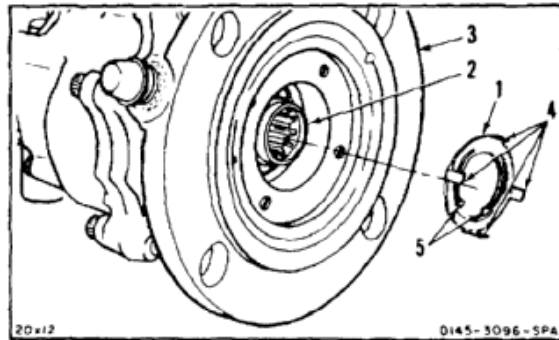

2. Install spring (6), ring (7), spring (8) with grommet (9), spring inward, on shaft (2).
3. Install seal (10) on shaft (2), flat side toward grommet (9). Slots (11) in plate shall engage with long tangs (4) of retainer (1).

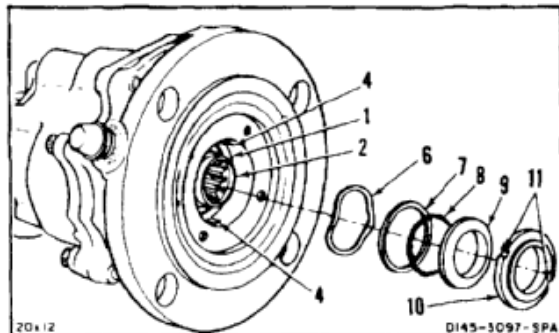

7-25 INSTALL HYDRAULIC PUMP COUPLING AND SEAL (AVIM) (Continued)

7-25

4. Install packing (12) on ring (13).
5. Install ring (13) on shaft (2), threaded holes (14) outboard.

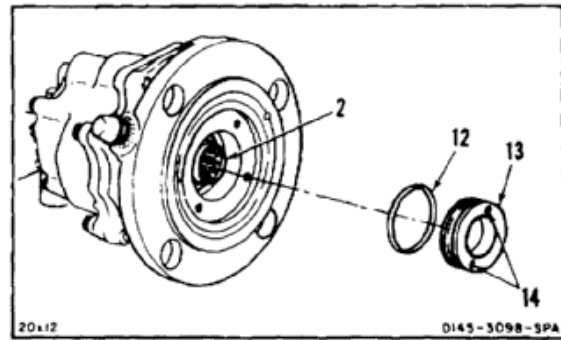

6. Position retainer (15) in pump (3). Install four washers (16) and screws (17). Use **9/64 inch** socket key.
7. Fill shaft (2) **one third** full of grease. Use grease (E190).

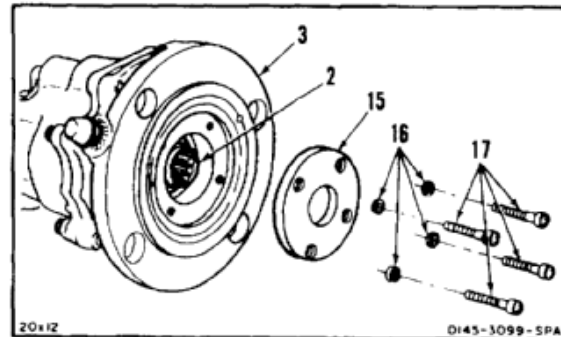

8. Install packing (18) in groove (19) of coupling (20).
9. Install coupling (20) in shaft (2), small end inward.
10. Slide sleeve (21) on screw (22). Install screw in coupling (20). If screw turns freely, replace screw.

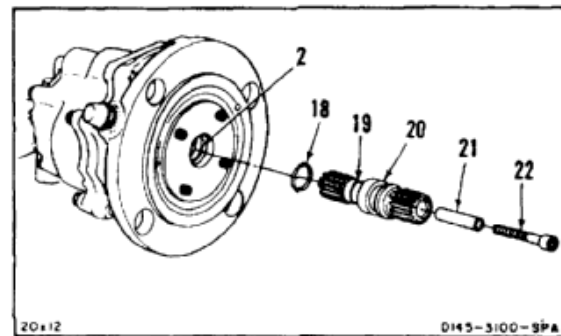
**INSPECT****FOLLOW-ON MAINTENANCE:**

Perform functional test (Task 7-26).

END OF TASK

INITIAL SETUP

Applicable Configurations:

All

Tools:

Hydraulic Repairer's Tool Kit, NSN 5180-00-323-4891
 Hydraulic Test Stand
 Shutoff Valve
 Restrictor Valve
 Pressure Gage, 500 psi
 Hose, 1/4 Inch, 500 psi
 Stopwatch
 Wrench, Open End

Materials:

None

Parts:

Pressure Caps

Personnel Required:

Aircraft Pnedraulics Repairer
 Inspector

Equipment Condition:

Off Helicopter Task
 Hydraulic Pump Installed in Crash Proof Box
 Test Setup

General Safety Instructions:**WARNING**

Use suitable crash proof box to shield personnel and equipment in case of failure during test.

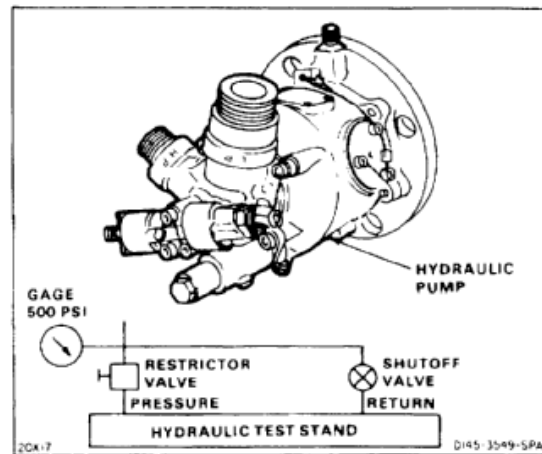

1. Install four pressure caps (1) on signal port (2), high pressure port (3), low pressure port (4), and seal drain port (5) of pump (6).
2. Connect test stand pressure hose (7) to case drain port (8).
3. Close valve (9).
4. Apply **300 psi** pressure to port (8). Adjust valve (10) for **300 psi** on gage (11). Maintain pressure for **5 minutes**.
5. Check for leaks at seal plate (12). There shall be no leaks.
6. Close valve (10). Open valve (9).

WARNING

Hydraulic fluid ejected under pressure can cause injury to personnel.
Hydraulic fluid sprayed into the air is a fire hazard.

7. Disconnect pressure hose (7) from port (8).
8. Remove four caps (1) from ports (2, 3, 4 and 5).
9. Turn shaft (13) by hand. Shaft shall turn evenly without binding or noise.

INSPECT**FOLLOW-ON MAINTENANCE:**

None

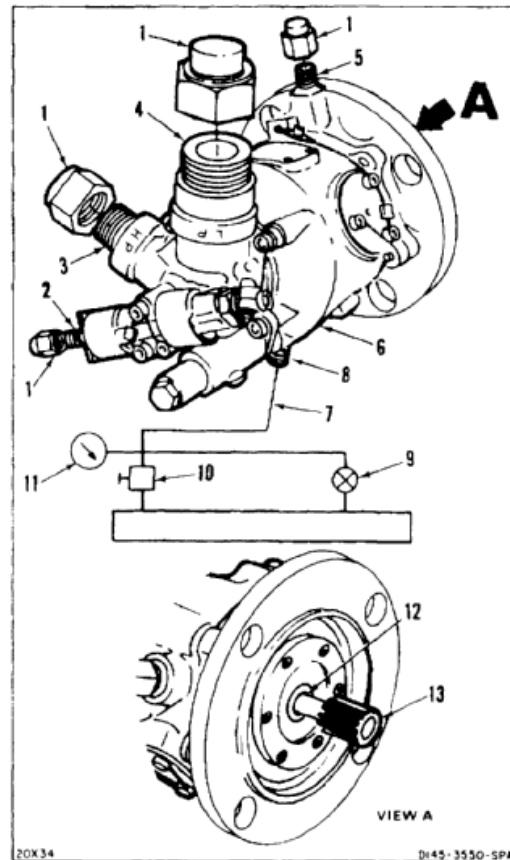

END OF TASK

INITIAL SETUP

Applicable Configurations:

All

Tools:

- Aircraft Mechanic's Tool Kit, NSN 5180-00-323-4692
- Torque Wrench, 30 to 150 Inch-Pounds
- Open-End Wrench, 1 Inch
- Open-End Wrench, 1-1/4 Inch
- Container, 2 Quart
- Hand Oiler

Materials:

- Oil (E254 or E254.1)
- Hydraulic Fluid (E199)
- Grease (E190)
- Dry Cleaning Solvent (E162)
- Cloths (E120)
- Gloves (E184.1)

Parts:

- Preformed Packings
- Caps

Personnel Required:

- Medium Helicopter Repairer
- Inspector

References:

TM 55-1520-240-23P

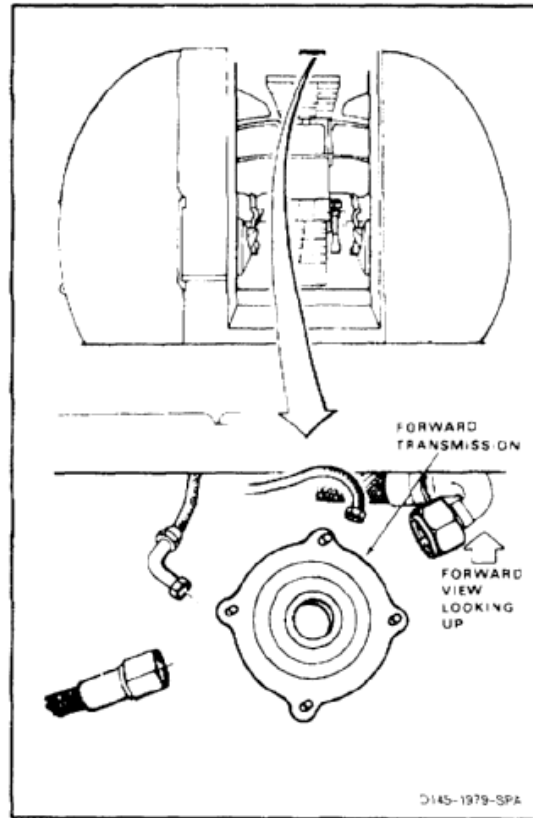

NOTE

Hydraulic Pump P/N 938555 (145HS100-3) is no longer the correct configuration after completion of ECP D213 and turnaround program (TB 1-1520-240-20-75). The correct P/N is 145HS100-4.

1. If pump (1) is being replaced, prepare pump as follows:
 - a. Remove four protective caps (2) from pump (1).
 - b. Drain preservative fluid from pump (1). Use container and cloths (E120) for spilled fluid. Wear gloves (E184.1).

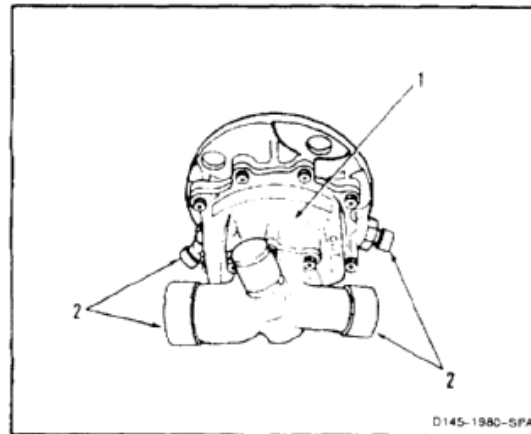

2. Install packing (3) and union (4) in IN port (5).
3. Install packing (6) and union (8) in OUT port (9).
4. Install packing (10) and union (12) in SD port (13).
- 4.1. Install packing (12.1) and union (12.2) in case drain port (12.3).

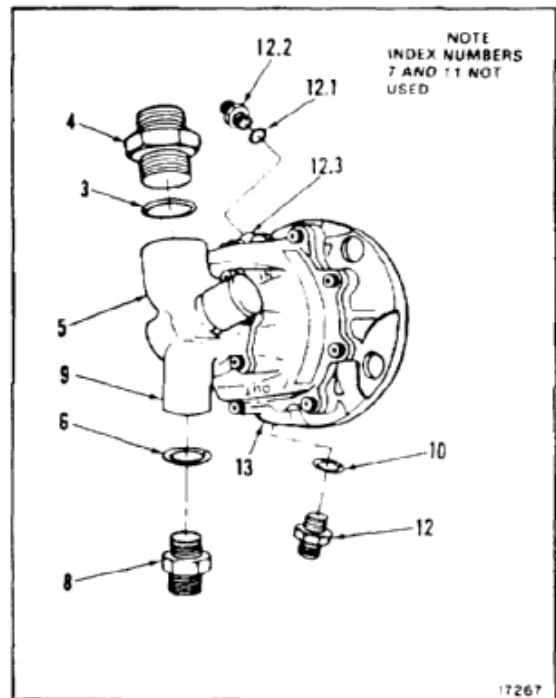

5. Install caps (2) on unions (4, 8, 12, and 12.2).

WARNING

Hydraulic fluid (E199) is toxic. It can irritate skin and cause burns. Avoid inhaling. Use only with adequate ventilation. Avoid contact with skin, eyes, or clothing. In case of contact, immediately flush skin or eyes with water for at least **15 minutes**. Get medical attention for eyes.

CAUTION

Do not install pump with dry case. This can cause internal damage to pump.

6. Fill pump case (14) through union (12.2) with hydraulic fluid (E199). Use hand oiler. Install cap (2) on fitting (16). Use cloths (E120) for spilled fluid. Wear gloves (E184.1).

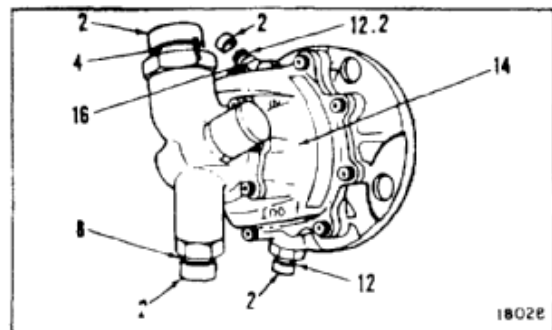

WARNING

Dry cleaning solvent (E162) is flammable and toxic. It can irritate skin and cause burns. Use only in well-ventilated area, away from heat and open flame. In case of contact, immediately flush skin or eyes with water for at least **15 minutes**. Get medical attention for eyes.

7. Remove protective material from spline (19). Clean spline (19). Use solvent (E162) and cloths (E120). Wear gloves (E184.1).
8. Coat spline (19) and packing (20) with grease (E190). Install packing on spline.
- 8.1. Install gasket (19.1) on pump (1).
9. Remove protective material from pump transmission mount.

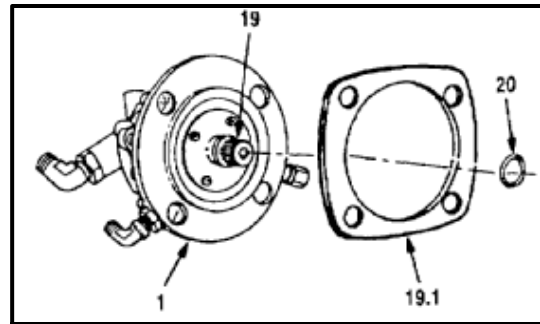
**NOTE**

When installing a Stratopower/ Dynapower pump there is a metal shim bonded to pump flange. If this shim comes unbonded from the pump flange, it does not have to be rebonded for installation.

10. Install pump (1) on four studs (21) with IN port (5) to right.

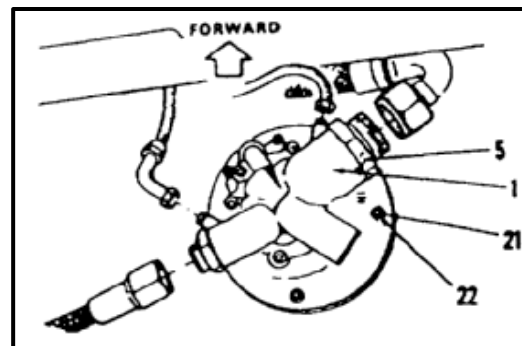
**WARNING**

Oil (E254 or E254.1) are toxic. They can irritate skin and cause burns. Avoid inhaling. Use only with adequate ventilation. Avoid contact with skin, eyes, or clothing. In case of contact, immediately flush skin or eyes with water for at least **15 minutes**. Get medical attention for eyes.

11. Install four nuts (22). Torque nuts wet with oil (E254 or E254.1) to **70 to 100 inch-pounds**.

NOTE

Torque on nuts (22) must be checked for **85 inch-pounds** after the first flight. Do not back off nuts before torquing.

7-27 INSTALL NO. 1 FLIGHT CONTROL HYDRAULIC PUMP (Continued)

7-27

- 11.1. Remove cap (2) from IN port (5).
12. Connect hose (23) to IN port (5). Remove tag. Use cloths (E120) for spilled fluid.
13. Remove cap (2) from OUT port (9).
14. Connect hose (24) to OUT port (9). Remove tag. Use cloths (E120) for spilled fluid.
15. Remove cap (2) from SD port (14).
16. Connect hose (25) to SD port (14). Remove tag. Use cloths (E120) for spilled fluid.
17. Remove cap (2) from case drain port (17).
18. Connect hose (26) to case drain port (17). Remove tag. Use cloths (E120) for spilled fluid.

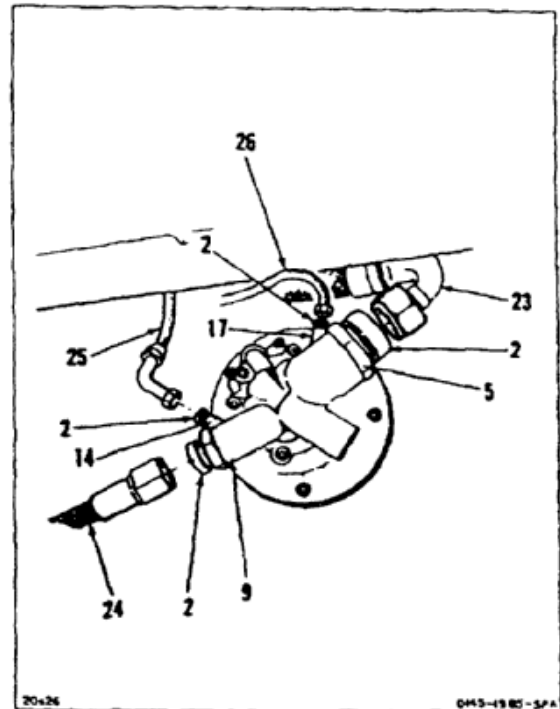
INSPECT**FOLLOW-ON MAINTENANCE:**

- Bleed flight control hydraulic system (Task 7-16).
- Perform operational check (TM 55-1520-240-T).
- Install forward transmission drip pan (Task 2-3).

END OF TASK

INITIAL SETUP

Applicable Configurations:

All

Tools:

Aircraft Mechanic's Tool Kit, NSN 5180-00-323-4692
 Torque Wrench, 30 to 150 Inch-Pounds
 Open-End Wrench, 1 Inch
 Open-End Wrench, 1-1/4 Inch
 Container, 2 Quart

Materials:

Oil (E254 or E254.1)
 Cloths (E120)
 Hydraulic Fluid (E199)
 Dry Cleaning Solvent (E162)
 Grease (E190)
 Gloves (E184.1)

Parts:

Preformed Packings
 Caps

Personnel Required:

Medium Helicopter Repairer
 Inspector

References:

TM 55-1520-240-23P

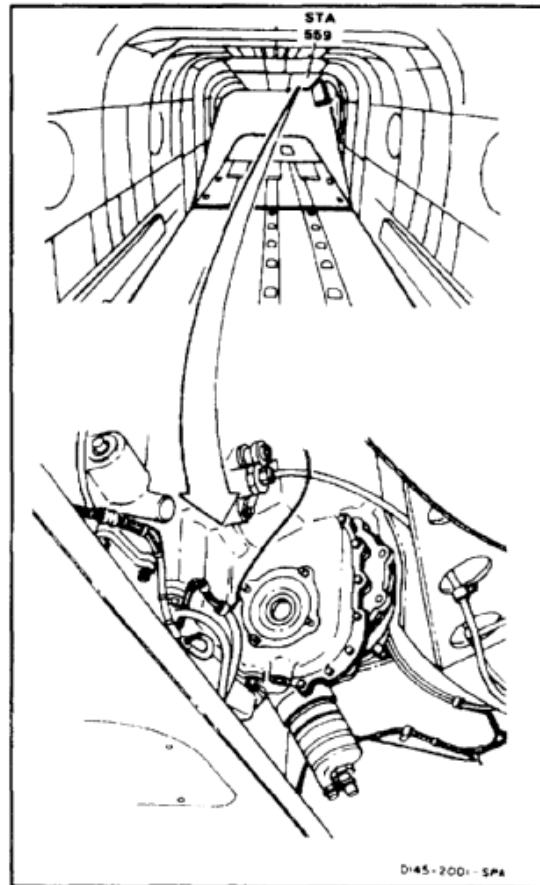
**NOTE**

Hydraulic Pump P/N 938555 (145HS100-3) is no longer the correct configuration after completion of ECP D213 and turnaround program (TB 1-1520-240-20-75). The correct P/N is 145HS100-4.

1. If pump (16) is being replaced, prepare pump as follows:
 - a. Remove four protective caps (16.1) from pump (16).
 - b. Drain preservative fluid from pump (16). Use container and cloths (E120) for spilled fluid. Wear gloves (E184.1).

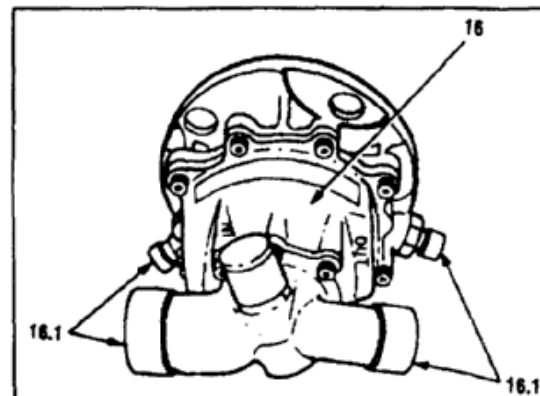

2. Install packing (1) and union (2) in IN port (3).
3. Install packing (4) and elbow (6) in OUT port (7). Tighten nut (8).
4. Install packing (9) and elbow (11) in SD port (12). Tighten nut (13).
5. Install packing (14) and union (15) in case drain port (15.1).

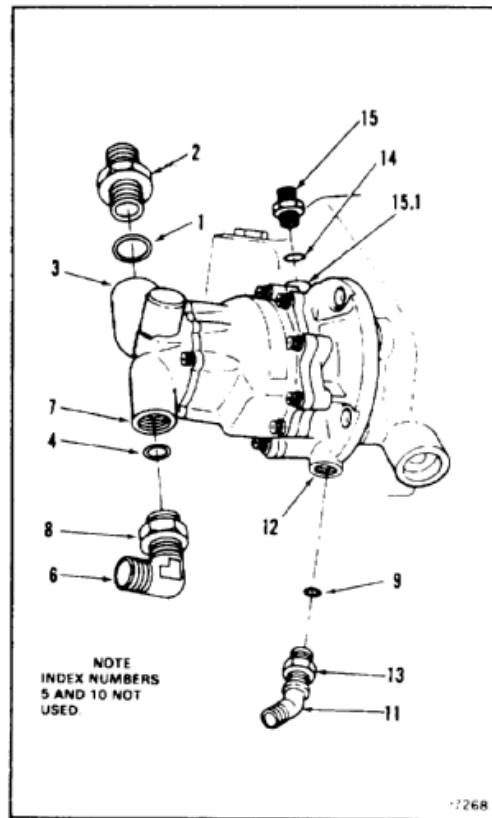

WARNING

Hydraulic fluid (E199) is toxic. It can irritate skin and cause burns. Avoid inhaling. Use only with adequate ventilation. Avoid contact with skin, eyes, or clothing. In case of contact, immediately flush skin or eyes with water for at least **15 minutes**. Get medical attention for eyes.

CAUTION

Do not install pump with dry case. This can cause internal damage to pump.

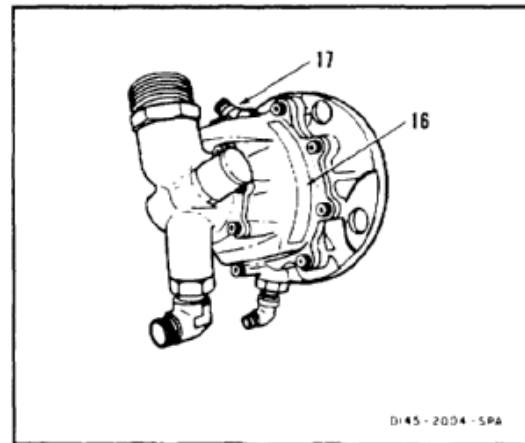

6. Fill pump case (16) through case drain port (17). Use hydraulic fluid (E199). Use cloths (E120) for spilled fluid. Wear gloves (E184.1).

WARNING

Dry cleaning solvent (E162) is flammable and toxic. It can irritate skin and cause burns. Use only in well-ventilated area, away from heat and open flame. In case of contact, immediately flush skin or eyes with water for at least **15 minutes**. Get medical attention for eyes.

7. Clean spline (19). Use solvent (E162). Use cloths for spilled fluid. Wear gloves (E184.1).
8. Coat spline (19) and packing (19.1) with grease (E190). Install packing (19.1) on spline.
- 8.1. Install gasket (19.2) on pump (1).
9. Remove protective material from pump transmission mount.

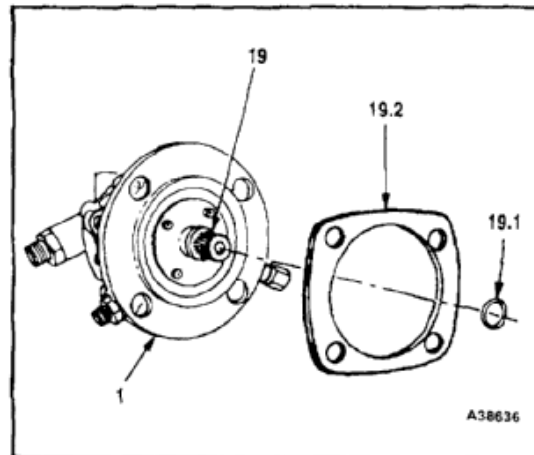

NOTE

When installing a Stratopower/ Dynapower pump there is a metal shim bonded to pump flange. If this shim comes unbonded from the pump flange. It does not have to be rebonded for installation.

10. Position pump (16) over four studs (20) with IN port (5) up. Rotate pump clockwise.
11. Connect hose (21) to union (15) of drain port (17).

WARNING

Oil (E254 or E254.1) are toxic. They can irritate skin and cause burns. Avoid inhaling. Use only with adequate ventilation. Avoid contact with skin, eyes, or clothing. In case of contact, immediately flush skin or eyes with water for at least **15 minutes**. Get medical attention for eyes.

12. Install four nuts (22). Torque nuts wet with oil (E254 or E254.1) to **70 to 100 inch-pounds**.

NOTE

Torque on nuts (22) must be checked for **85 inch-pounds** after the first flight. Do not back nuts off before torquing.

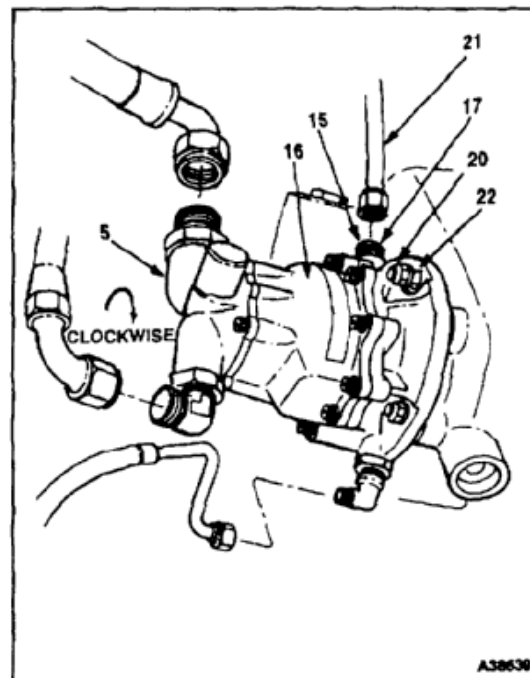

7-28 INSTALL NO.2 FLIGHT CONTROL HYDRAULIC PUMP (Continued)

7-28

13. Connect hose (23) to IN port (5). Remove tag. Use cloths (E120) for spilled fluid.
14. Connect hose (24) to OUT port (9). Remove tag. Use cloths (E120) for spilled fluid.
15. Deleted.
16. Connect hose (26) to case drain port (19). Remove tag. Use cloths (E120) for spilled fluid.

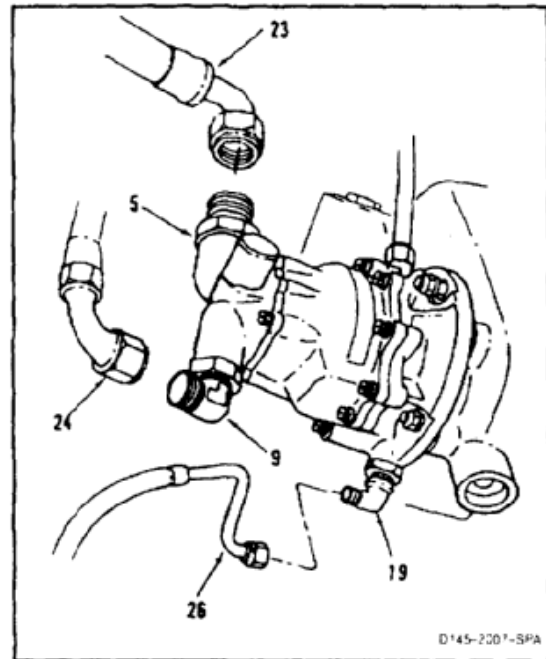
**INSPECT****FOLLOW-ON MAINTENANCE:**

- Bleed flight control hydraulic system (Task 7-16).
- Perform operational check of flight control system (TM 55-1520-240-T).
- Close left transmission access door (Task 2-2)
- Close cargo ramp (TM 55-1520-240-T).

END OF TASK

INITIAL SETUP

Flight Control Accumulator Depressurized (Task 1-63)
 Left and Right Forward Work Platforms Open (Task 2-2)

Applicable Configurations:

All

General Safety Instructions:

Tools:

Aircraft Mechanic's Tool Kit, NSN 5180-00-323-4692
 Container, 2 Quart

Materials:

Cloths (E135)
 Paper Tags (E264)
 Gloves (E186)

Personnel Required:

Medium Helicopter Repairer

Equipment Condition:

Battery Disconnected (Task 1-39)
 Electrical Power Off
 Hydraulic Power Off
 No. 1 Flight Control Reservoir Drained (Task 1-60.1)
 Manual Drain Flight Control Hydraulic System Reservoir (Task 7-113)

WARNING

Hydraulic fluid (E199) is toxic. It can irritate skin and cause burns. Avoid inhaling. Use only with adequate ventilation. Avoid contact with skin, eyes, or clothing. In case of contact, immediately flush skin or eyes with water for at least **15 minutes**. Get medical attention for eyes.

WARNING

Hydraulic fluid ejected under pressure can cause injury to personnel. Hydraulic fluid sprayed into the air is a fire hazard.

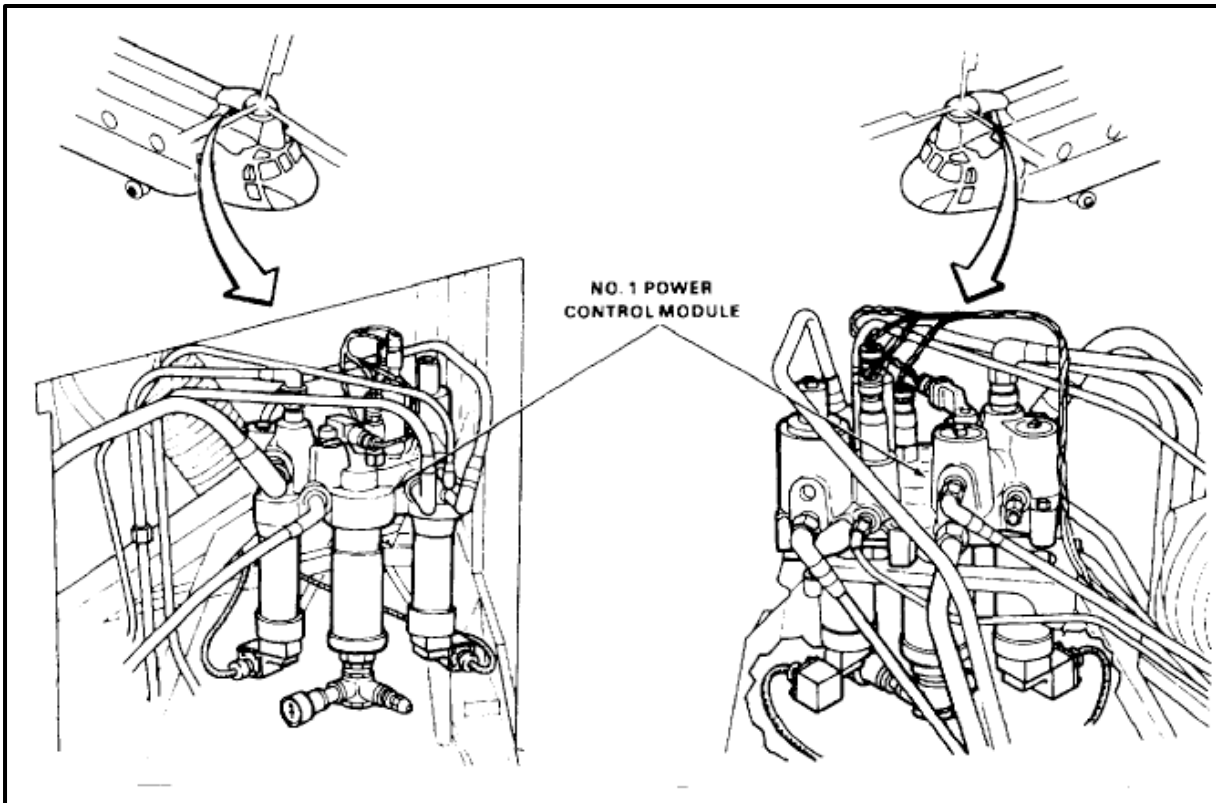

7-29 REMOVE NO. 1 POWER CONTROL MODULE (Continued)

7-29

1. On right side of module (1), tag and disconnect six tubes (2). Use cloths (E135) for spilled fluid. Use gloves (E186).
2. Tag and disconnect six connectors (3).

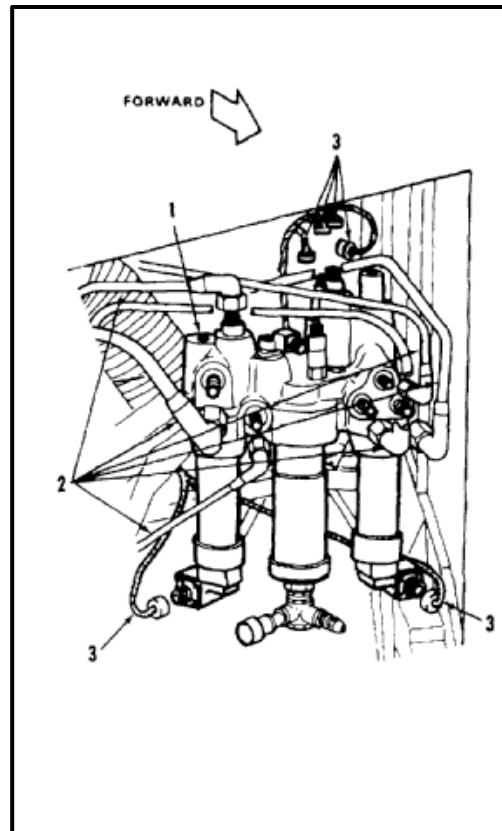

3. On left side of module (1), tag and disconnect four tubes (2). Use cloths (E135) for spilled fluid. Wear gloves (E186).
4. Remove three bolts (4) and washers (5).
5. Remove module (1).

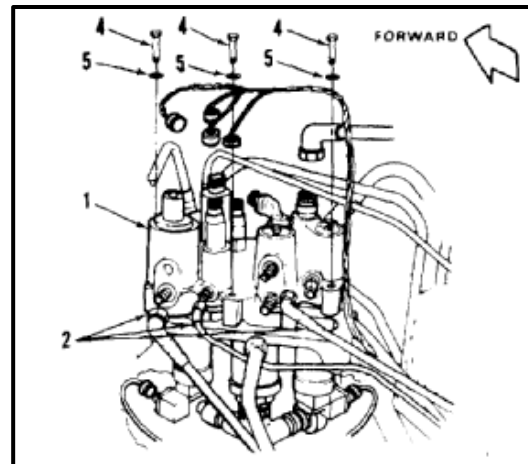
**FOLLOW-ON MAINTENANCE:**

None

END OF TASK

INITIAL SETUP

Applicable Configurations:

All

Tools:

Aircraft Mechanic's Tool Kit, NSN 5180-00-323-4692

Materials:

None

Personnel Required:

Medium Helicopter Repairer
Inspector

References:

TM 55-1520-240-23P

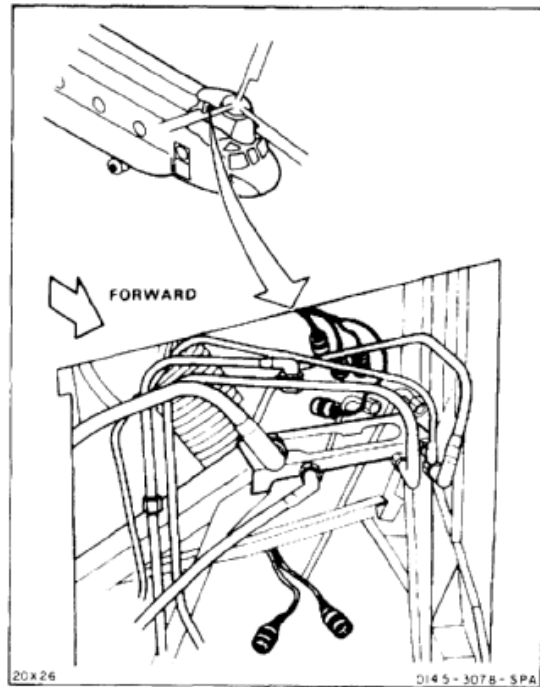

1. Position module (1) on bracket (2).
2. Install three bolts (3) and washers (4) loosely.

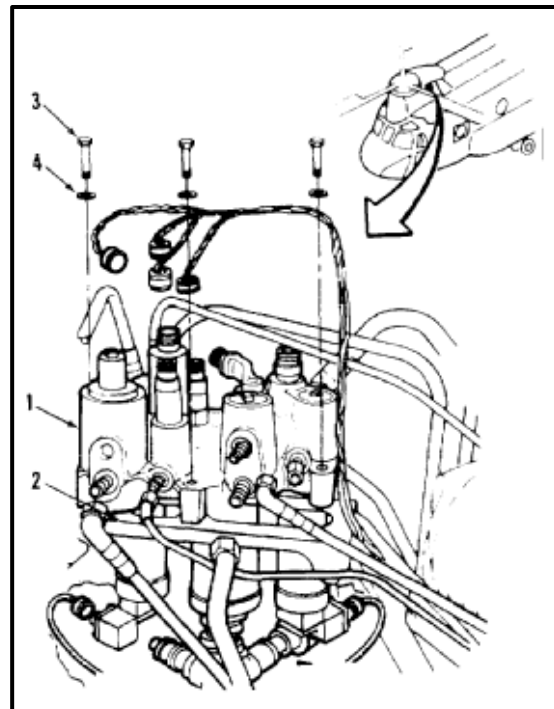

3. Connect tube (5) to port (6). Remove tag.
4. Connect tube (7) to SYS RTNCV port (8). Remove tag.
5. Connect tube (9) to port (10). Remove tag.
6. Connect tube (11) to port (12). Remove tag.
7. Connect connector (13) to PRESS XMTR receptacle (14). Remove tag.
8. Connect connector (15) to SYSPLTV plug (16). Remove tag.

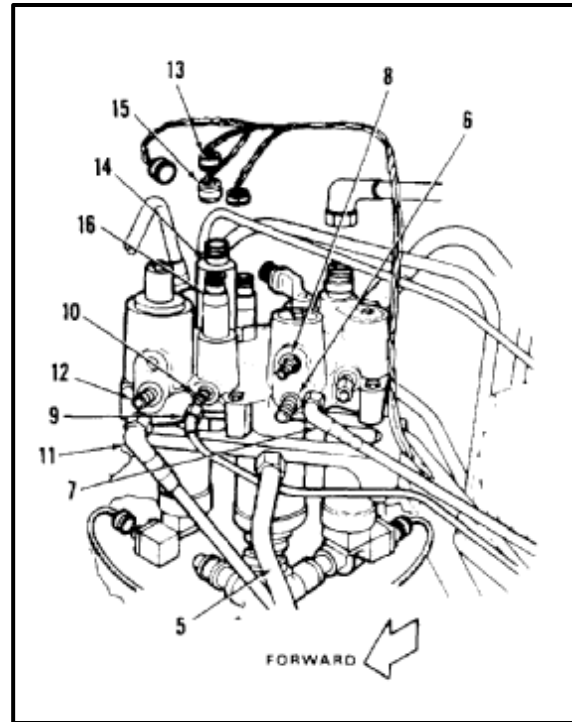

9. Connect tube (17) to port (18). Remove tag.
10. Connect tube (19) to RSVR RTN port (20). Remove tag.
11. Connect tube (21) to SYS RET port (22). Remove tag.
12. Connect tube (23) to port (24). Remove tag.
13. Connect tube (25) to port (26). Remove tag.
14. Connect tube (27) to PTU PRESS port (28). Remove tag.
15. Tighten three bolts (3).

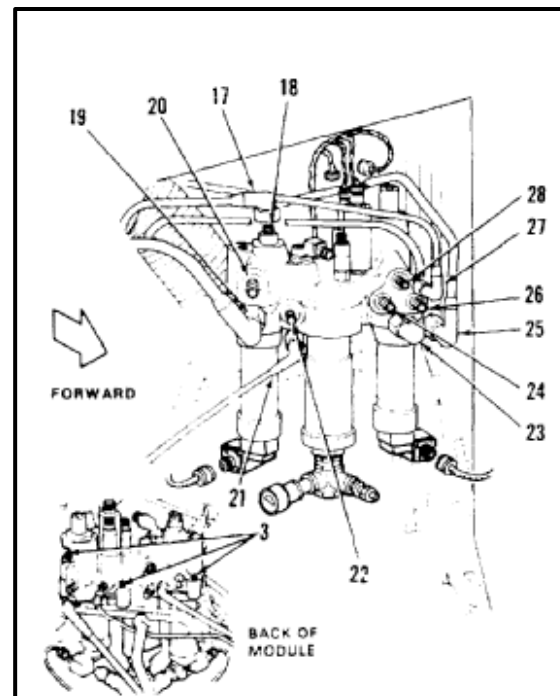

16. Connect connector (29) to SYS PRESS SW receptacle (30). Remove tag.
17. Connect connector (31) to FLT PUMP FAIL indicator (32). Remove tag.
18. Connect connector (33) to switch (34). Remove tag.
19. Connect connector (35) to switch (36). Remove tag.

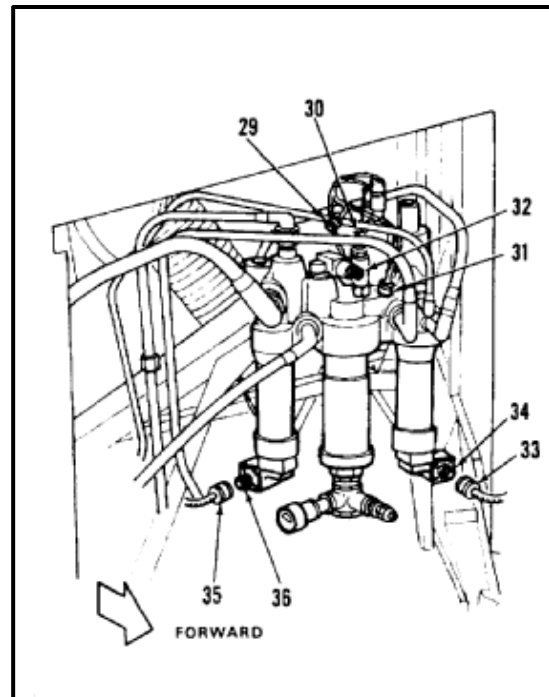
INSPECT**FOLLOW-ON MAINTENANCE:**

- Bleed flight control hydraulic system (Task 7-16).
- Service flight control accumulator (Task 1-63).
- Perform operational check (TM 55-1520-240-T).
- Service flight control reservoir (Task 1-60).
- Close left and right forward work platforms (Task 2-2).

END OF TASK

INITIAL SETUP

Flight Control Accumulator Depressurized (Task 1-63)
 Left and Right Pylon Access Covers Removed (Task 2-2)

Applicable Configurations:

All

Tools:

Aircraft Mechanic's Tool Kit, NSN 5180-00-323-4692

Materials:

- Cloths (E135)
- Paper Tags (E264)
- Gloves (E186)

Personnel Required:

Medium Helicopter Repairer

Equipment Condition:

- Battery Disconnected (Task 1-39)
- Electrical Power Off
- Hydraulic Power Off
- No. 2 Flight Control Reservoir Drained (Task 1-60.1)
- Manual Drain Flight Control Hydraulic System Reservoir (Task 7-113)

General Safety Instructions:

WARNING

Hydraulic fluid (E199) is toxic. It can irritate skin and cause burns. Avoid inhaling. Use only with adequate ventilation. Avoid contact with skin, eyes, or clothing. In case of contact, immediately flush skin or eyes with water for at least **15 minutes**. Get medical attention for eyes.

WARNING

Hydraulic fluid ejected under pressure can cause injury to personnel. Hydraulic fluid sprayed into the air is a fire hazard.

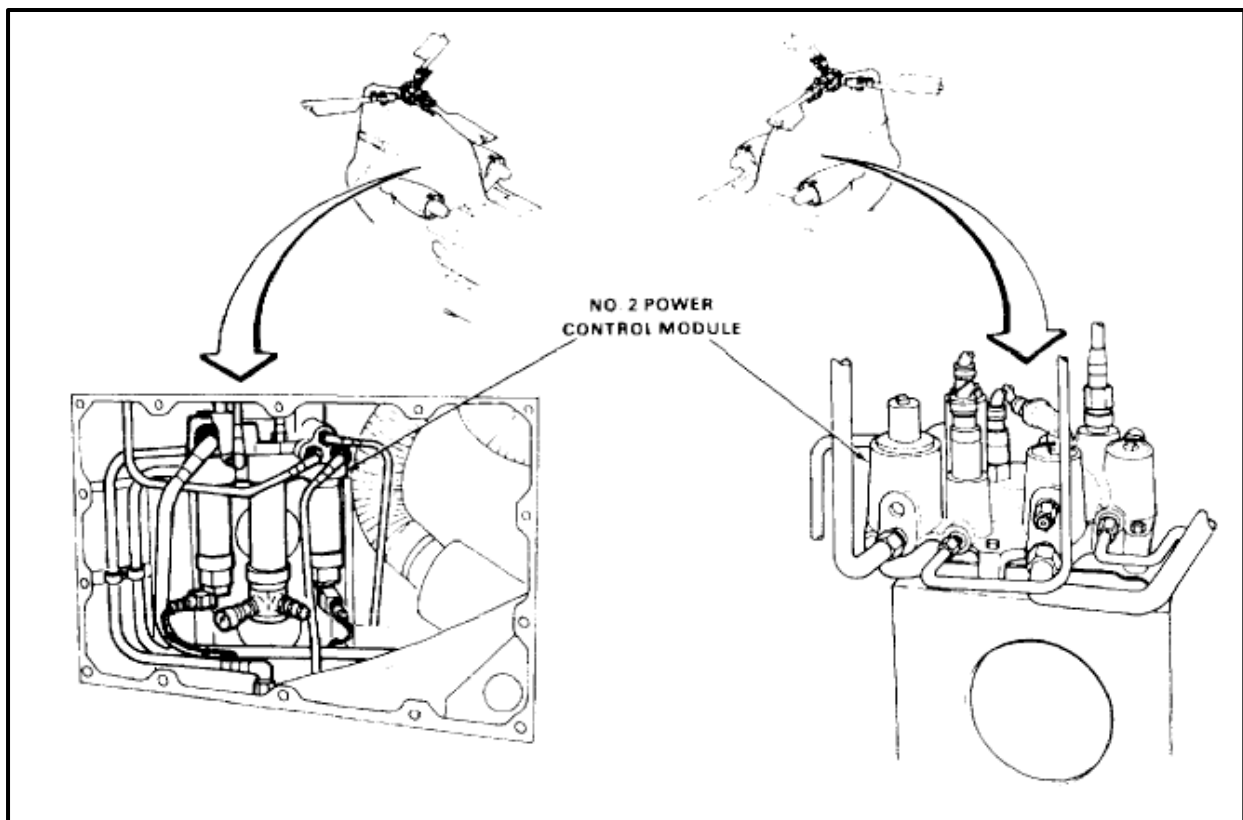

1. On right side of module (1), tag and disconnect five tubes (2). Use cloths (E135) for spilled fluid. Wear gloves (E186).
2. Remove lockwire from two connectors (3). Tag and disconnect two connectors from module (1).

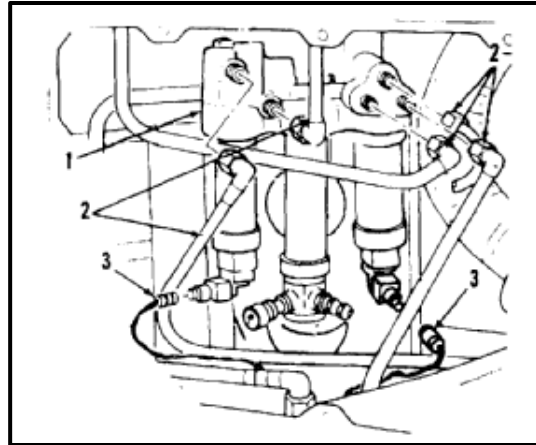

3. On left side of the module (1), tag and disconnect five tubes (4). Use cloths (E135) for spilled fluid. Wear gloves (E186).
4. Remove lockwire from four connectors (5). Tag and disconnect four connectors from module (1).
5. Remove three bolts (6) and washers (7).
6. Remove module (1).

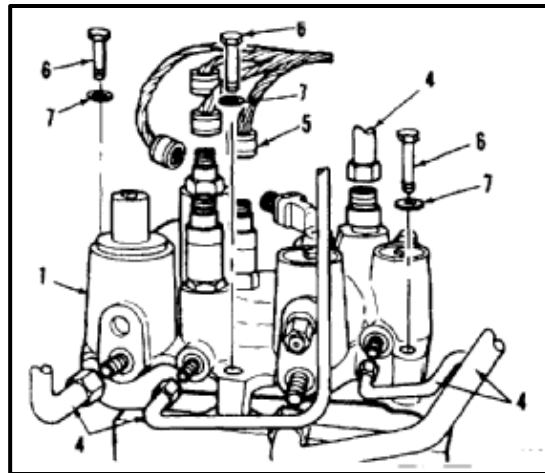
**FOLLOW-ON MAINTENANCE:**

None

END OF TASK

7-180

INITIAL SETUP

Applicable Configurations:

All

Tools:

Aircraft Mechanic's Tool Kit, NSN 51 80-00-323-4692

Materials:

None

Personnel Required:

Medium Helicopter Repairer
Inspector

References:

TM 55-1520-240-23P

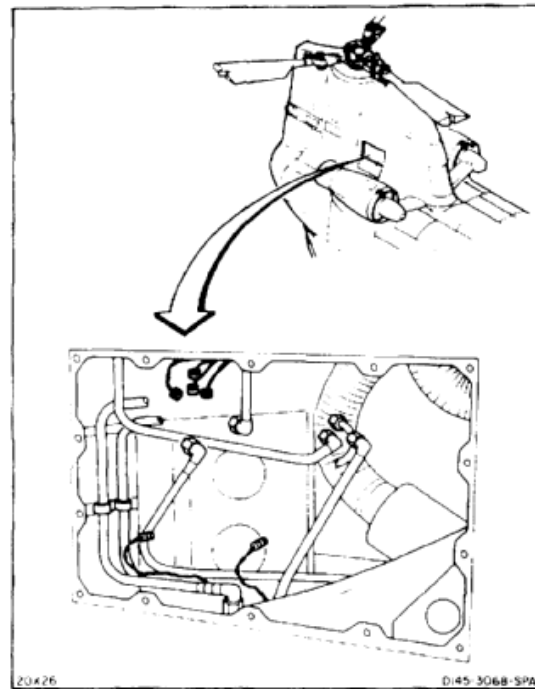

1. Position module (1) on bracket (2).
2. Install three bolts (3) and washers (4) loosely.

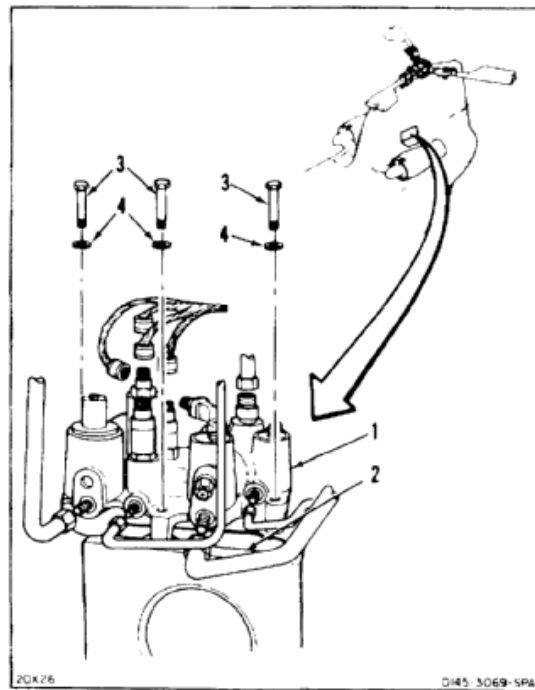

3. Connect tube (5) to port (6). Remove tag.
4. Connect tube (7) to SYS RTNCV port (8). Remove tag.
5. Connect tube (9) to port (10). Remove tag.
6. Connect tube (11) to port (12). Remove tag.
7. Connect tube (13) to port (14). Remove tag.
8. Connect connector (15) to PRESS XMTR receptacle (16). Remove tag.
9. Connect connector (17) to SYSPLTV receptacle (18). Remove tag.
10. Connect connector (19) to SYS PRESS SW receptacle (20). Remove tag.

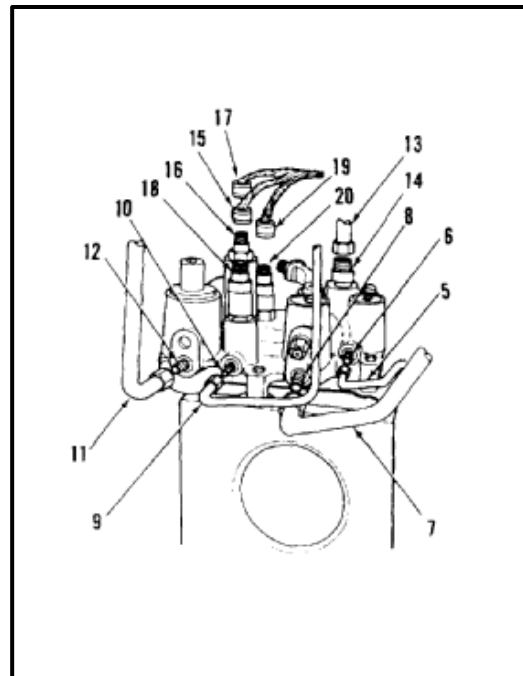

11. Connect connector (21) to switch (22). Remove tag.
12. Connect connector (23) to switch (24). Remove tag.
13. Connect tube (25) to RSVR RTN port (26). Remove tag.
14. Connect tube (27) to SYS RET port (28). Remove tag.
15. Connect tube (29) to port (30). Remove tag.
16. Connect tube (31) to port (32). Remove tag.
17. Connect tube (33) to PTU PRESS port (34). Remove tag.
18. Connect connector (35) to FLT PUMP FAIL indicator (36). Remove tag.
19. Tighten three bolts (3).

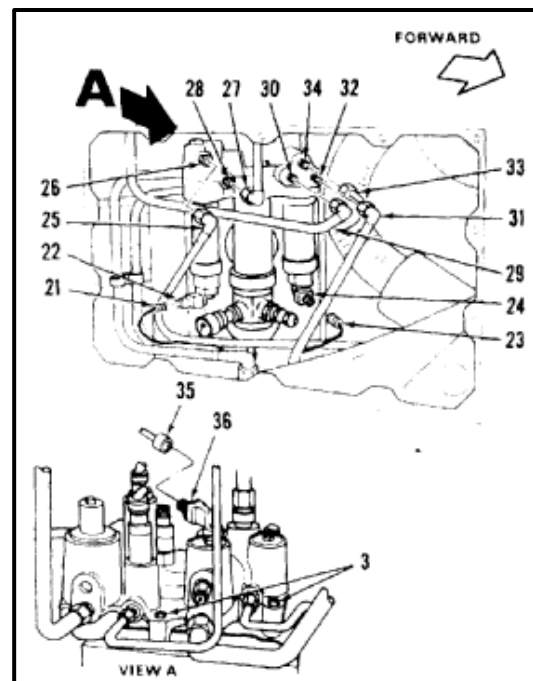

INSPECT

FOLLOW-ON MAINTENANCE:

- Bleed flight control hydraulic system (Task 7-16).
- Service flight control accumulator (Task 1-63).
- Service flight control reservoir (Task 1-61).
- Perform operational check (TM 55-1520240-T).
- Install left and right access covers (Task 2-2).

END OF TASK

7-33 REMOVE NO. 1 OR NO. 2 POWER CONTROL MODULE FILTER ELEMENT

7-33

INITIAL SETUP**General Safety Instructions:****Applicable Configurations:**

All

Tools:

Aircraft Mechanic's Tool Kit, NSN 5180-00-323-4692
 Container, 2 Quart
 Strap Wrench

Materials:

Cloths (E135)
 Gloves (E184.1)

Personnel Required:

Medium Helicopter Repairer

References

Task 7-349

Equipment Condition:

Battery Disconnected (Task 1-39)
 Electrical Power Off
 Hydraulic Power Off
 Right Forward Work Platform Open or Right
 Pylon Access Door Removed (Task 2-2)
 Flight Control System Accumulator Depressurized
 (Task 1-63)

WARNING

Hydraulic fluid (E199) is toxic. It can irritate skin and cause burns. Avoid inhaling. Use only with adequate ventilation. Avoid contact with skin, eyes, or clothing. In case of contact, immediately flush skin or eyes with water for at least **15 minutes**. Get medical attention for eyes.

WARNING

Hydraulic fluid ejected under pressure can cause injury to personnel. Hydraulic fluid sprayed into the air is a fire hazard.

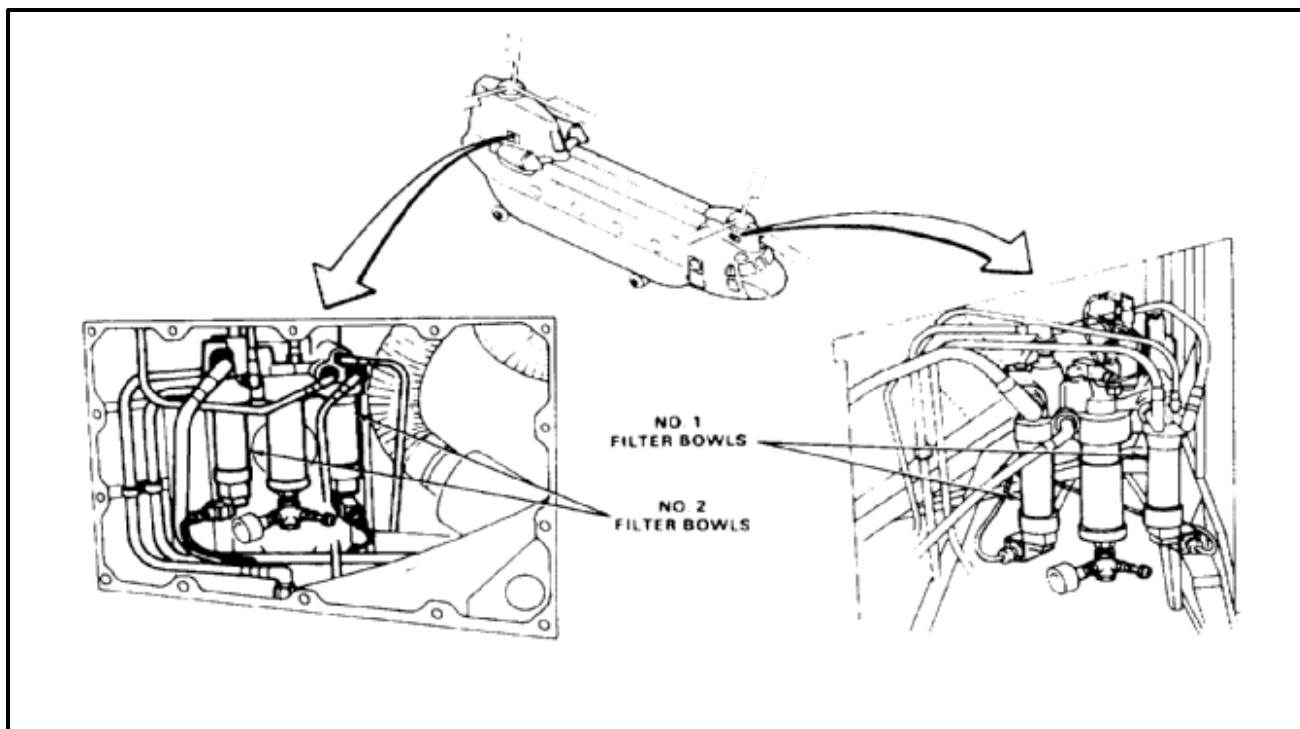

NOTE

There are four filter elements, two in No. 1 and two in No. 2 module. Procedure is same to remove any filter element. No. 1 module is shown here.

NOTE

If diaphragm must be removed, refer to (Task 7-349).

1. Loosen nut (1).
2. Turn fitting (2) to allow clearance for removal of filter bowl (3).
3. Disconnect connector (4) from switch (5).



Bowl contains hydraulic fluid. Do not spill.

4. Remove lockwire from filter bowl (3). Remove filter bowl (3). Use cloths (E135) for spilled fluids. Wear gloves (E184.1).
- 4.1. Remove element removal spring (6) from filter port (7) of module (8).

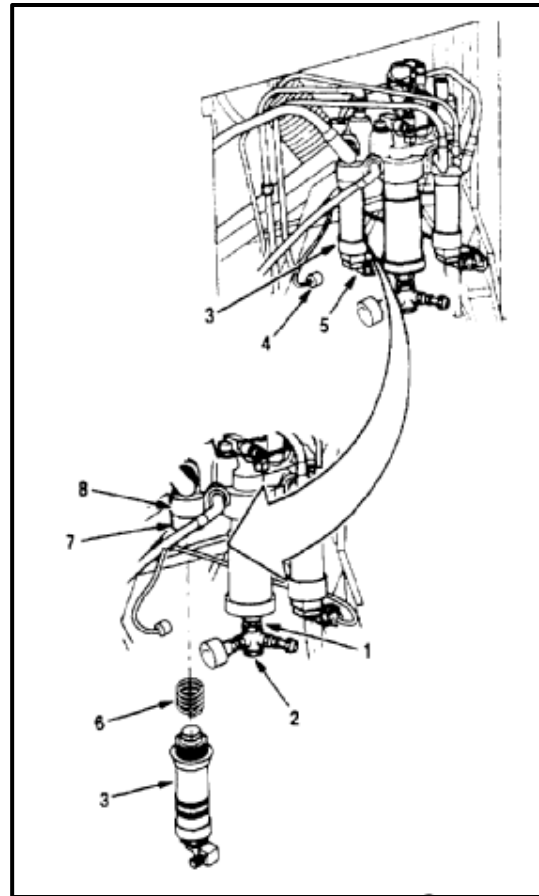

5. Remove element (9) from filter bowl (3).

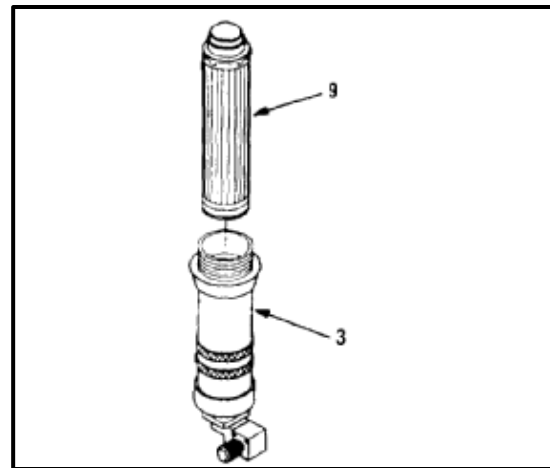
**FOLLOW-ON MAINTENANCE:**

None

END OF TASK

7-34 INSTALL NO. 1 OR NO. 2 POWER CONTROL MODULE FILTER ELEMENT

7-34

INITIAL SETUP**Applicable Configurations:**

All

Tools:

Aircraft Mechanic's Tool Kit, NSN 5180-00-323-4692
Torque Wrench, 0 to 150 Inch-Pound
Crowfoot Attachment, 11/16 Inch

Materials:

Cloths (E135)
Lockwire (E231)
Gloves (E184.1)

Parts:

Element

Personnel Required:

Medium Helicopter Repairer
Inspector

References:

TM 55-1520-240-23P
Task 1-63
Task 7-349

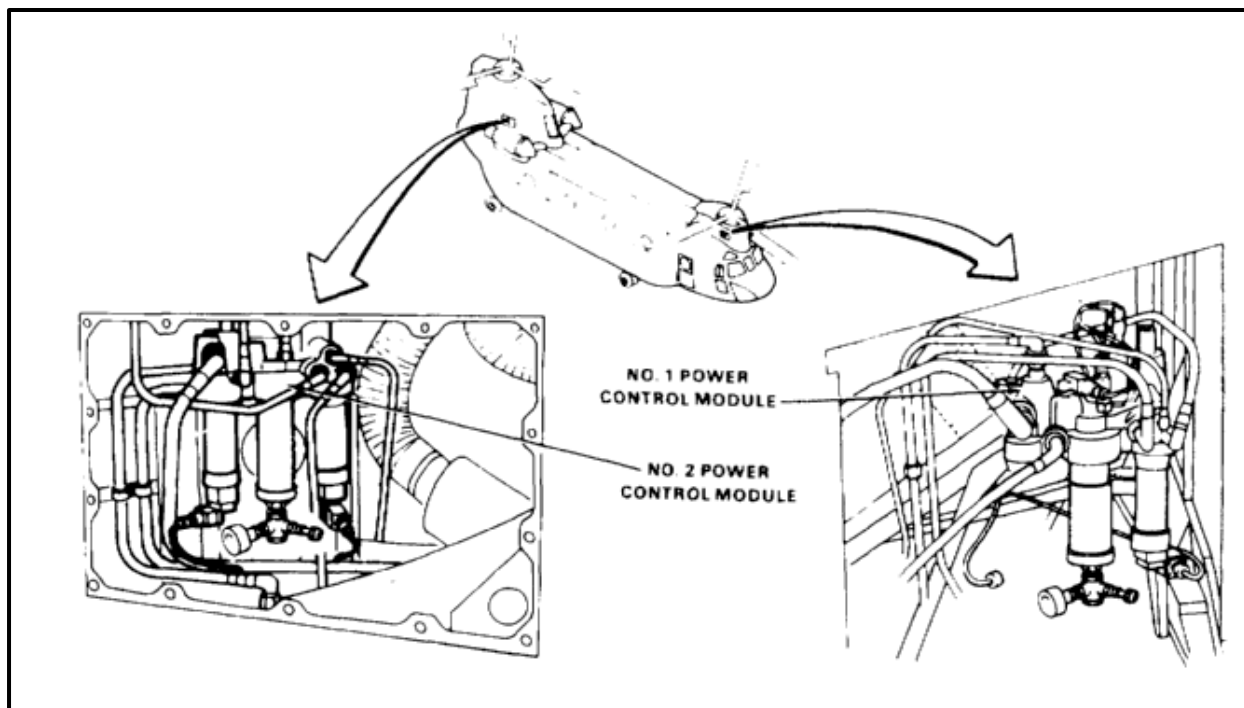

NOTE

There are four filter elements, two in No. 1 and two in No. 2 module. Procedure is same to install any filter element. No. 1 module is shown here.

NOTE

If diaphragm was removed, refer to (Task 7-349) for proper installation.

1. Install element (1) in filter bowl (2).

WARNING

Hydraulic fluid (E199) is toxic. It can irritate skin and cause burns. Avoid inhaling. Use only with adequate ventilation. Avoid contact with skin, eyes, or clothing. In case of contact, immediately flush skin or eyes with water for at least **15 minutes**. Get medical attention for eyes.

WARNING

Hydraulic fluid ejected under pressure can cause injury to personnel. Hydraulic fluid sprayed into the air is a fire hazard.

CAUTION

Install element removal spring (2.1) with weld down.

- 1.1. Install element removal spring (2.1) into filter port (3) of module (4).
2. Install filter bowl (2), in filter port (3), of module (4). Use cloths (E135) for spilled fluid. Tighten filter bowl (2) hand tight. Wear gloves (E184.1).
3. Lockwire filter bowl (2) to module (4). Use lockwire (E231).
4. Connect connector (5) to receptacle (6).

INSPECT

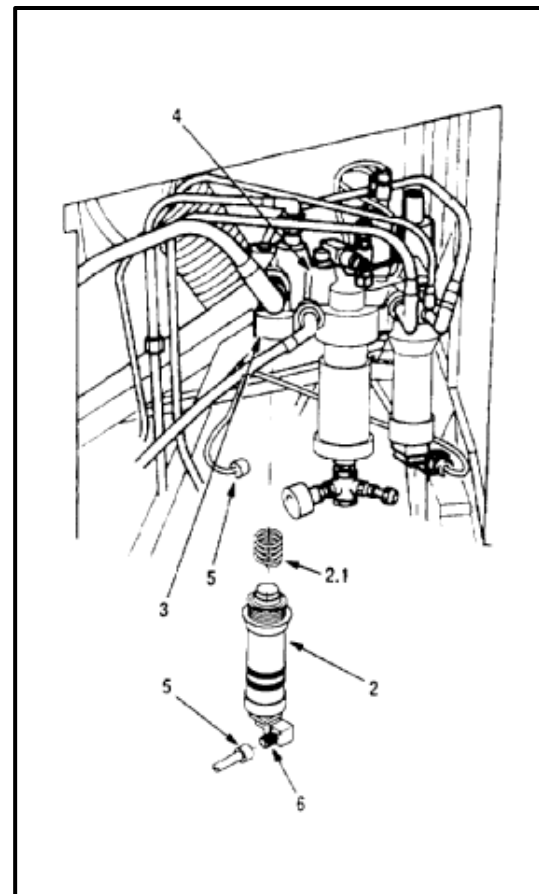
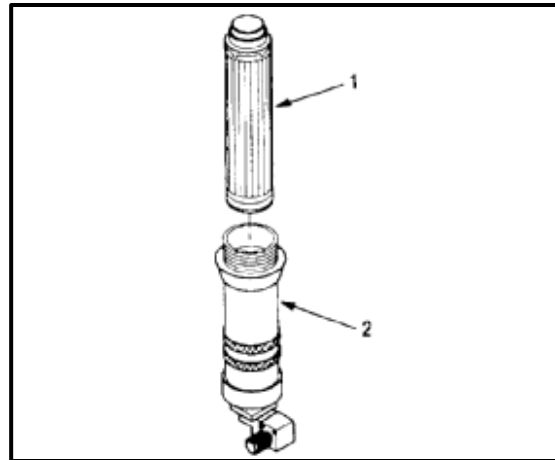

5. Rotate fitting (7) **90°** to the left so that gage (8) is accessible for servicing.
6. Tighten nut (9). Torque nut to **135 inch-pounds**.
7. Check pressure gage (8). Gage shall indicate **1500 psi**. If not, service accumulator (10) (Task 1-63).

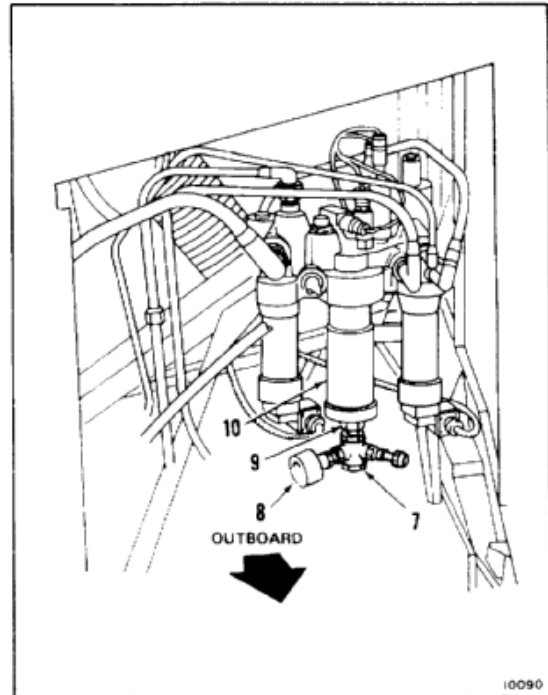

FOLLOW-ON MAINTENANCE:

- Bleed flight control hydraulic system (Task 7-16).
- Service flight control accumulator (Task 1-63).
- Perform operational check (TM 55-1520-240-T).
- Close right forward work platform or install right pylon access door (Task 2-2).

END OF TASK

INITIAL SETUP

General Safety Instructions:

Applicable Configurations:

All

Tools:

Aircraft Mechanic's Tool Kit, NSN 5180-00-323-4692

Materials:

Cloths (E135)

Personnel Required:

Medium Helicopter Repairer

Equipment Condition:

- Battery Disconnected (Task 1-39)
- Electrical Power Off
- Hydraulic Power Off
- Right Forward Work Platform Open or Right Pylon Access Door Removed (Task 2-2)

WARNING

Hydraulic fluid (E199) is toxic. It can irritate skin and cause burns. Avoid inhaling. Use only with adequate ventilation. Avoid contact with skin, eyes, or clothing. In case of contact, immediately flush skin or eyes with water for at least **15 minutes**. Get medical attention for eyes.

WARNING

Hydraulic fluid ejected under pressure can cause injury to personnel. Hydraulic fluid sprayed into the air is a fire hazard.

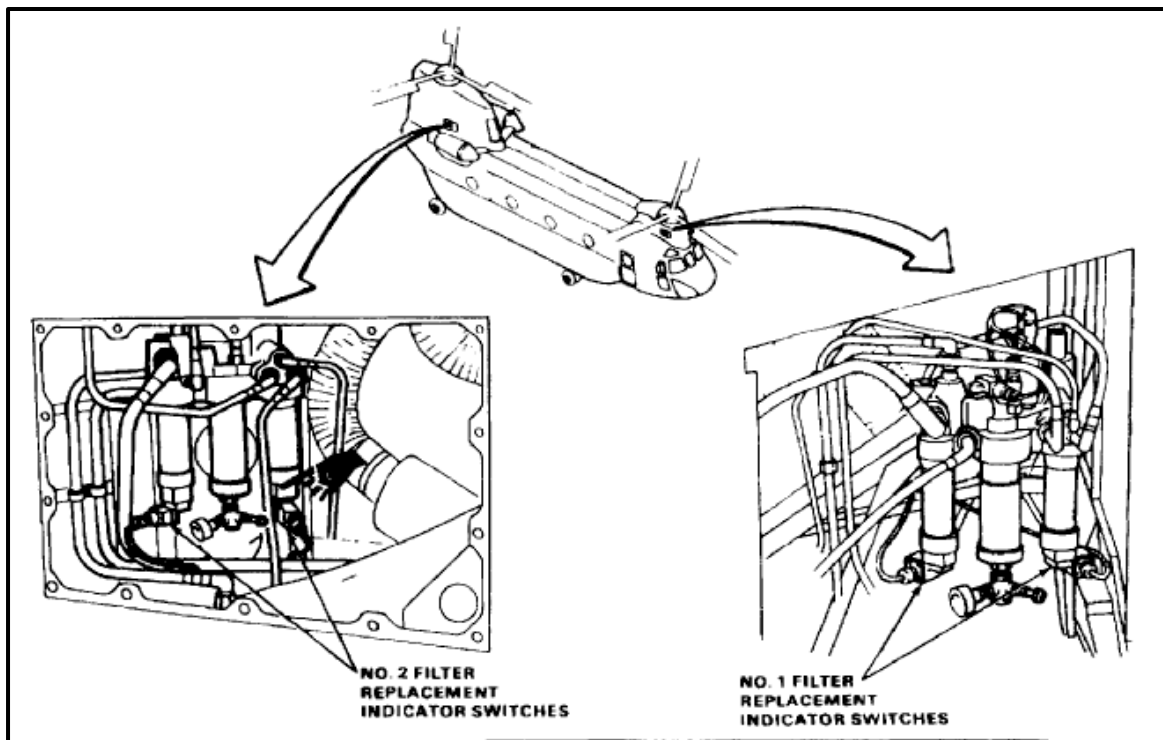

7-35 REMOVE NO. 1 OR NO. 2 POWER CONTROL MODULE FILTER CHANGE SWITCH (Continued)

7-35

NOTE

There are four filter switches, two in No. 1 and two in No. 2 module. Procedure is same to remove any filter switch. No. 1 module is shown here.

1. Disconnect connector (1) from switch (2).

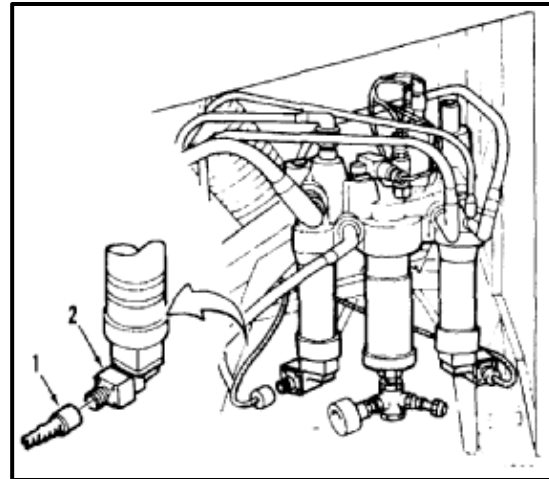

2. Remove lockwire from four screws (3). Remove four screws from switch (2).
3. Remove switch (2) and two packings (4). Use cloths to catch spilled fluid.

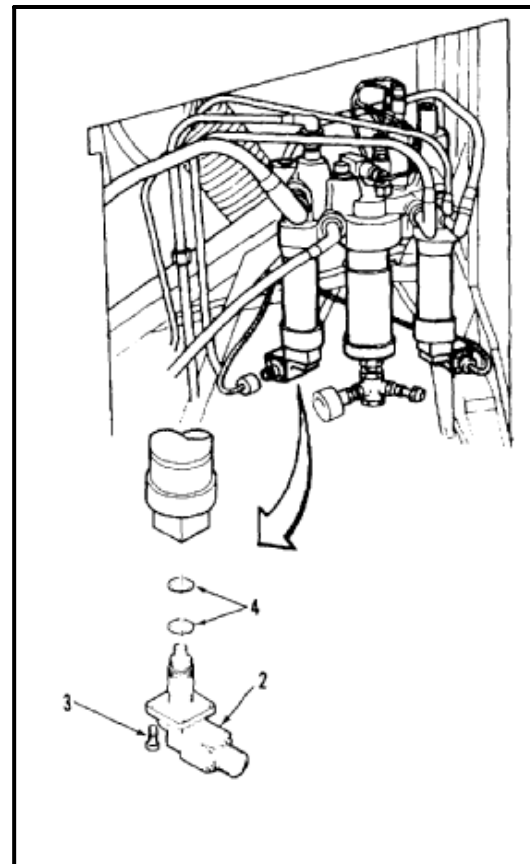
**FOLLOW-ON MAINTENANCE:**

None

END OF TASK

INITIAL SETUP

Applicable Configurations:

All

Tools:

Aircraft Mechanic's Tool Kit, NSN 5180-00-323-4692
Torque Wrench, 0 to 150 Inch-Pounds

Materials:

Hydraulic Fluid (E199)
Lockwire (E231)

Parts:

Preformed Packings
Retainers

Personnel Required:

Medium Helicopter Repairer
Inspector

References:

TM 55-520-240-23P

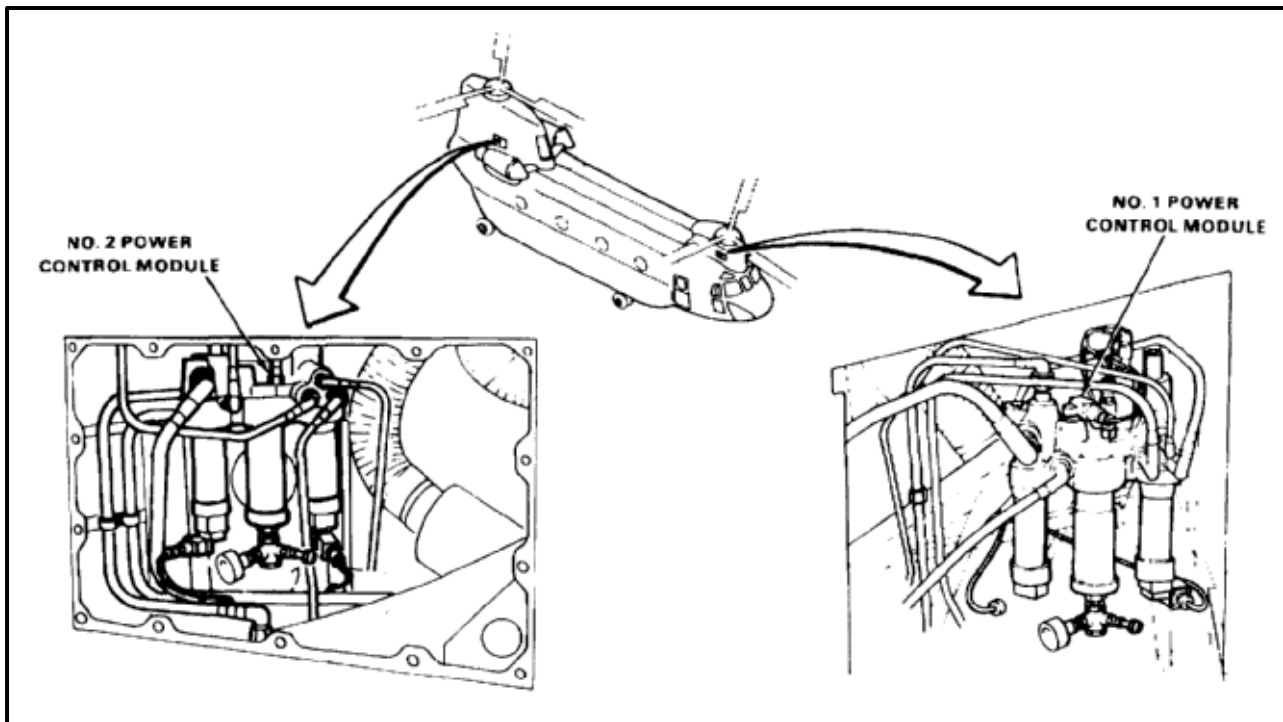

7-36 INSTALL NO. 1 OR NO. 2 POWER CONTROL MODULE FILTER CHANGE SWITCH (Continued)

7-36

NOTE

There are four filter switches, two in No. 1 and two in No. 2 module. Procedure is same to install any filter switch. No. 1 module is shown here.

1. If not already installed, install one retainer (1) and two packings (2) on switch (3).
2. Install switch (3) in bowl (4) with connector inboard.
3. Lubricate screws (5) with hydraulic fluid (E199). Install four screws (5) in switch (3). Torque screws to **32 to 34 inch-pounds** in diagonal sequence.
4. Lockwire screws (5). Use lockwire (E231).

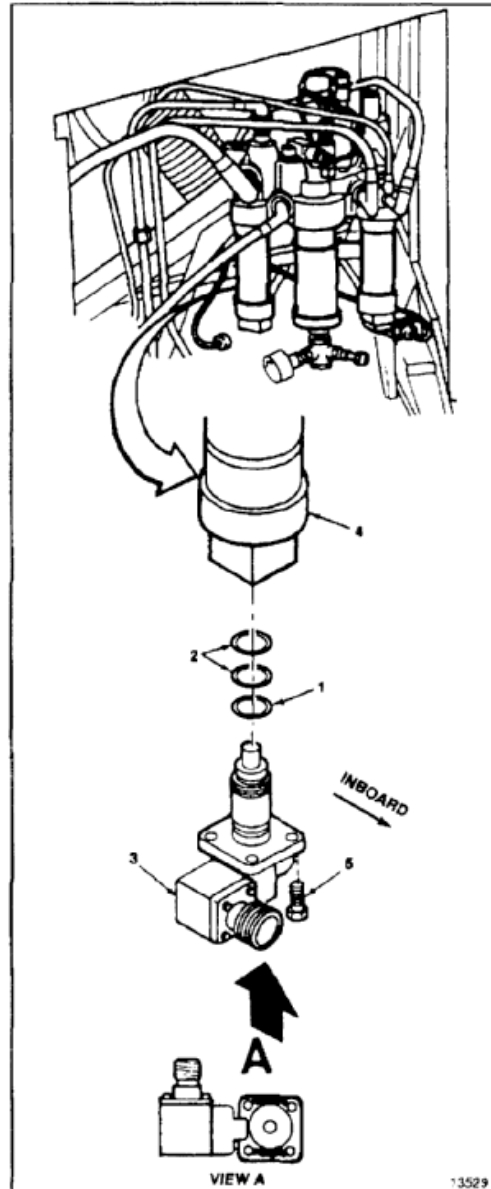

5. Connect connector (6) to switch (3).

INSPECT

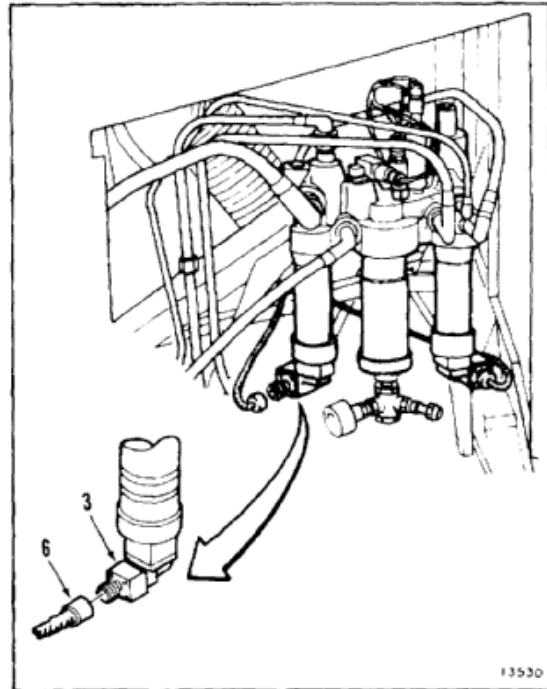

FOLLOW-ON MAINTENANCE:

- Bleed flight control hydraulic system (Task 7-16).
- Service flight control accumulator (Task 1-63).
- Perform operational check (TM 55-1520-240-T).
- Close right forward work platform or right pylon access door (Task 2-2).

END OF TASK

INITIAL SETUP

General Safety Instructions:**Applicable Configurations:**

All

Tools:

Aircraft Mechanic's Tool Kit, NSN 5180-00-323-4692

Materials:Cloths (E135)
Gloves (E186)**Personnel Required:**

Medium Helicopter Repairer

Equipment Condition:Battery Disconnected (Task 1-39)
Electrical Power Off
Hydraulic Power Off
Right Forward Work Platform or Right Pylon Access
Door Open (Task 2-2)**WARNING**

Hydraulic fluid (E199) is toxic. It can irritate skin and cause burns. Avoid inhaling. Use only with adequate ventilation. Avoid contact with skin, eyes, or clothing. In case of contact, immediately flush skin or eyes with water for at least **15 minutes**. Get medical attention for eyes.

WARNING

Hydraulic fluid ejected under pressure can cause injury to personnel. Hydraulic fluid sprayed into the air is a fire hazard.

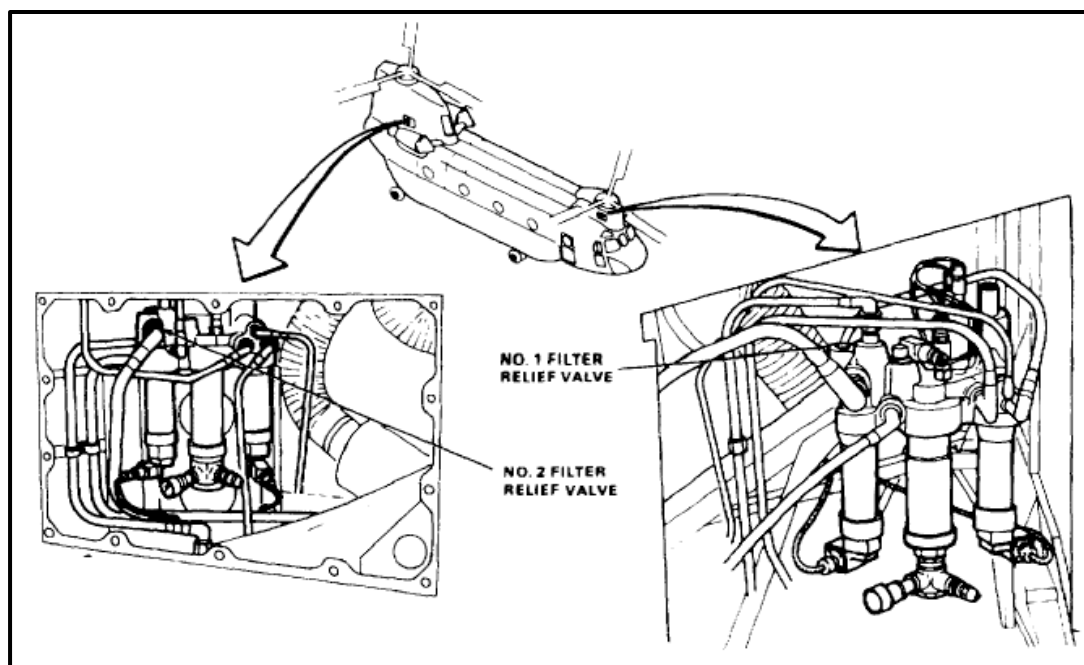

7-37 REMOVE NO. 1 OR NO. 2 POWER CONTROL MODULE FILTER RELIEF VALVE (Continued)

7-37

NOTE

There are two filter relief valves, one in No. 1 and one in No. 2 module. Procedure is same to remove any relief valve. No. 1 module is shown here.

1. Remove lockwire from valve (1) and remove valve and two packings (2) from module (3). Use cloths (E135) for spilled fluid. Use gloves (E186).

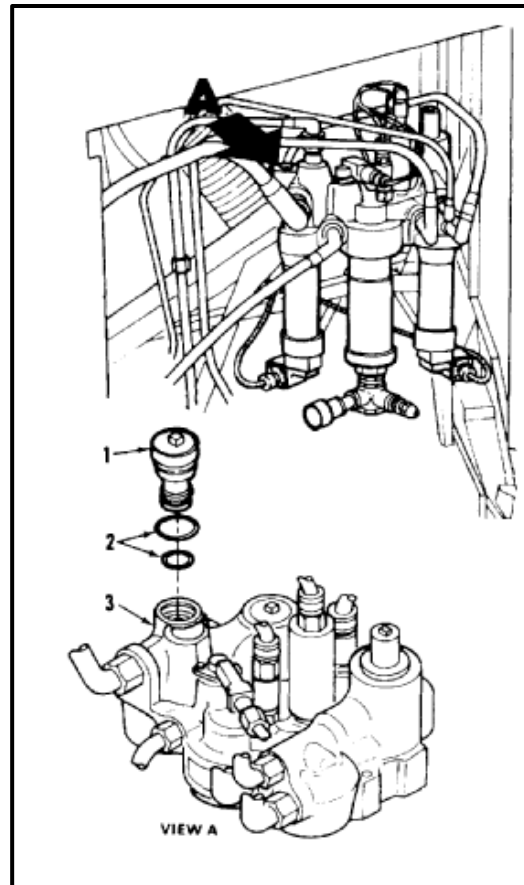
**FOLLOW-ON MAINTENANCE:**

None

END OF TASK

7-194

INITIAL SETUP

Applicable Configurations:

All

Tools:

Aircraft Mechanic's Tool Kit, NSN 5180-00-323-4692

Materials:

Lockwire (E231)

Parts:

Preformed Packings

Personnel Required:

Medium Helicopter Repairer
Inspector

References:

TM 55-1520-240-23P

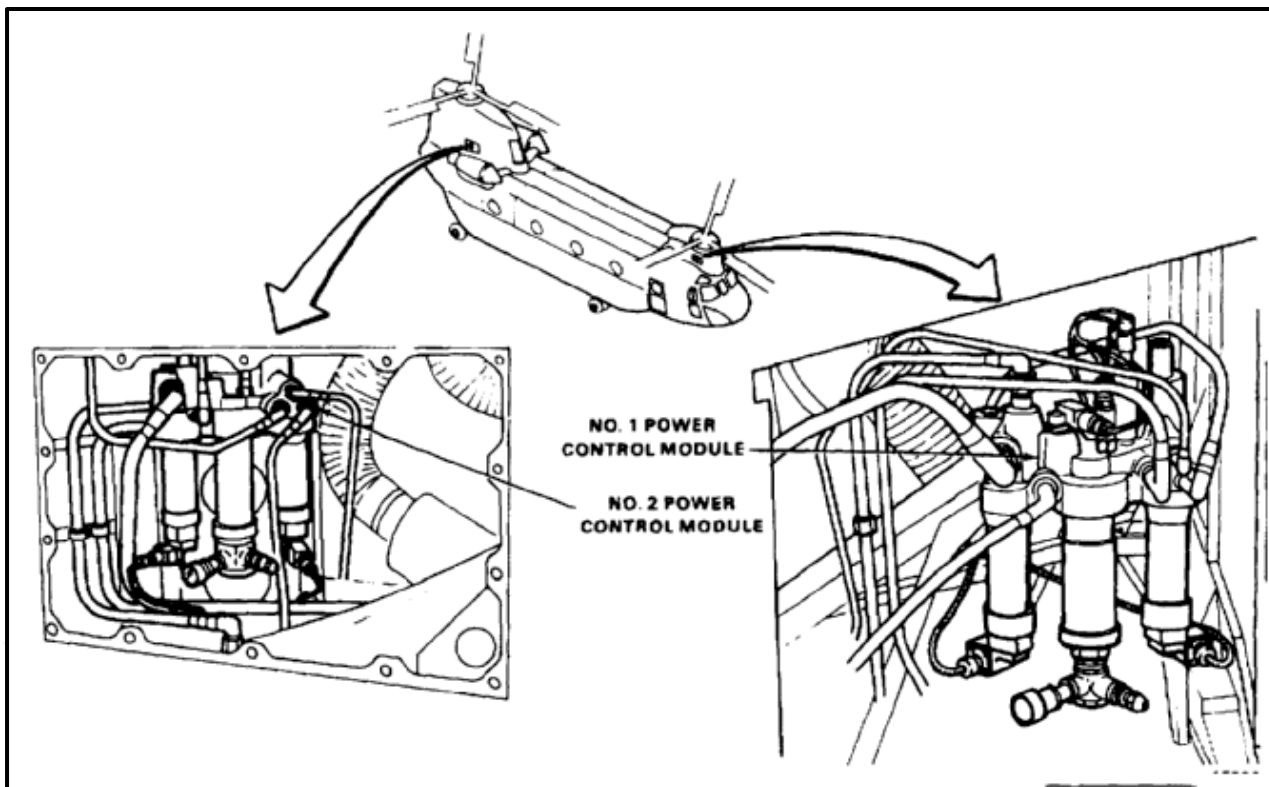

7-38 INSTALL NO. 1 OR NO. 2 POWER CONTROL MODULE FILTER RELIEF VALVE (Continued)

7-38

NOTE

There are two filter relief valves, one in No. 1 and one in No. 2 module. Procedure is same to install any relief valve. No. 1 module is shown here.

1. Install two packings (1 and 2) on valve (3).
2. Install valve (3) in module (4).
3. Lockwire valve (3) to valve (5). Use lockwire (E231).

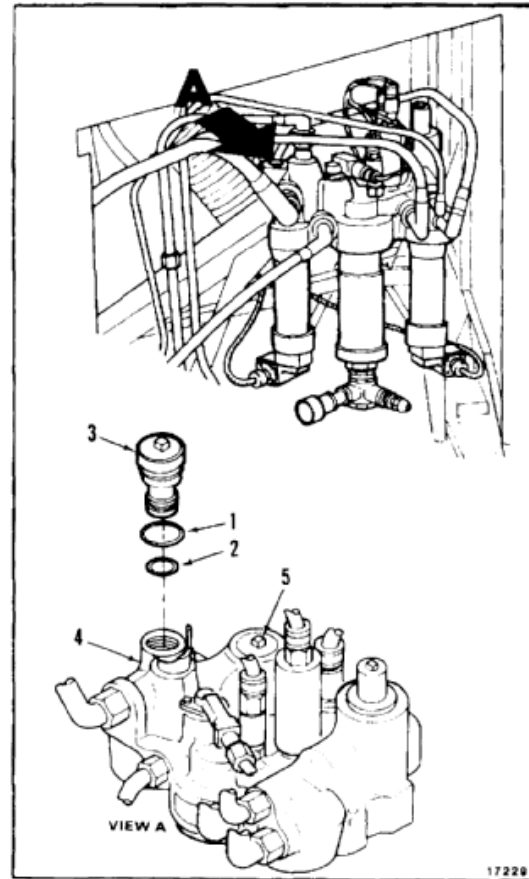
INSPECT**FOLLOW-ON MAINTENANCE:**

Service flight control system (Task 1-60, 1-61, 1-62, or 1-63).

Perform operational check (TM 55-1520-240-T).

Close right forward work platform or right pylon access door (Task 2-2).

END OF TASK

INITIAL SETUP

General Safety Instructions:

Applicable Configurations:

All

Tools:

Aircraft Mechanic's Tool Kit, NSN 5180-00-323-4692
Strap Wrench

Materials:

Cloths (E135)
Gloves (E186)

Personnel Required:

Medium Helicopter Repairer

Equipment Condition:

Battery Disconnected (Task 1-39)
Electrical Power Off
Hydraulic Power Off
Left Forward Work Platform or Right Pylon Access
Door Open (Task 2-2)

WARNING

Hydraulic fluid (E199) is toxic. It can irritate skin and cause burns. Avoid inhaling. Use only with adequate ventilation. Avoid contact with skin, eyes, or clothing. In case of contact, immediately flush skin or eyes with water for at least **15 minutes**. Get medical attention for eyes.

WARNING

Hydraulic fluid ejected under pressure can cause injury to personnel. Hydraulic fluid sprayed into the air is a fire hazard.

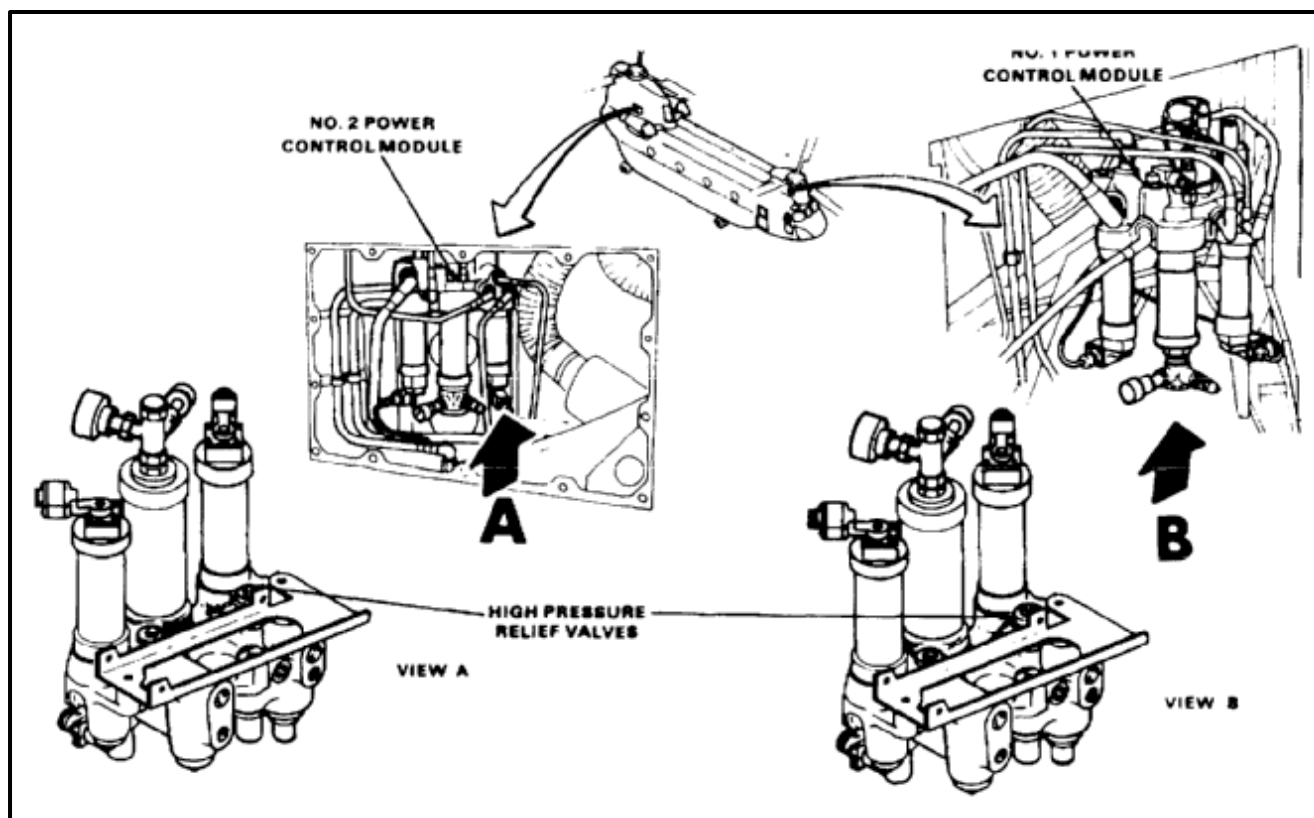

TO REMOVE RELIEF VALVE FROM NO. 1 MODULE OR NO. 2 MODULE

1. Disconnect connector (1) from switch (2).
2. Remove two screws (3) from switch (2).

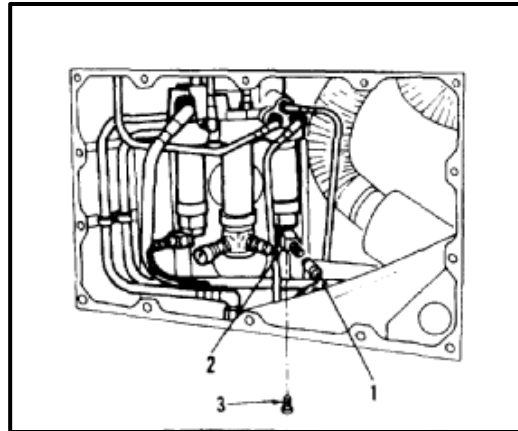

3. Remove lockwire from bowl (4). Remove bowl from module (5). Use cloths (E135) for spilled fluid. Use gloves (E186). Use strap wrench.

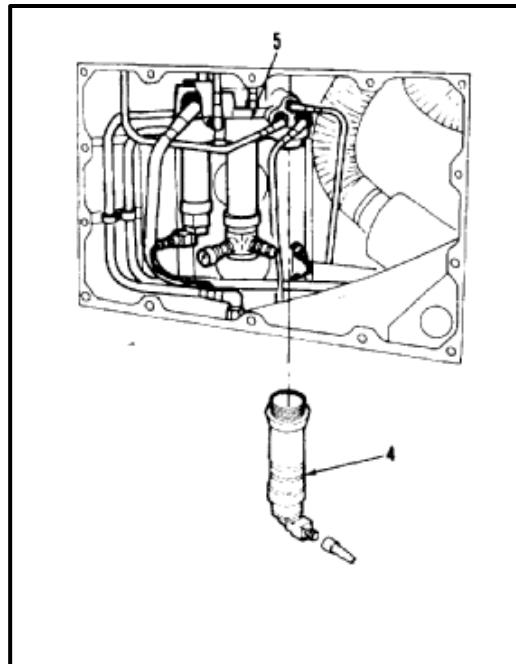

7-39 REMOVE NO. 1 OR NO. 2 POWER CONTROL MODULE HIGH PRESSURE RELIEF VALVE (Continued)

7-39

4. Remove lockwire from valve (6).
5. Remove valve (6) from module (5) by turning nut (7). Use cloths (E135) for spilled fluid.
6. Remove two retainers (8) and two packings (9) from valve (6).

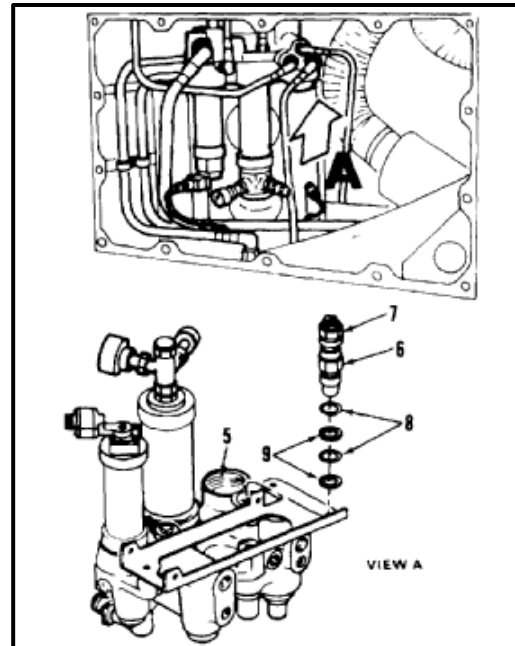
**FOLLOW-ON MAINTENANCE:**

None

END OF TASK

INITIAL SETUP

Applicable Configurations:

All

Tools:

Aircraft Mechanic's Tool Kit, NSN 5180-00-323-4692
 Box Wrench, 13/16 Inch
 Container, 2 Quart

Materials:

Cloths (E135)
 Lockwire (E231)

Parts:

Preformed Packings
 Retainers

Personnel Required:

Medium Helicopter Repairer
 Inspector

References:

TM 55-1520-240-23P

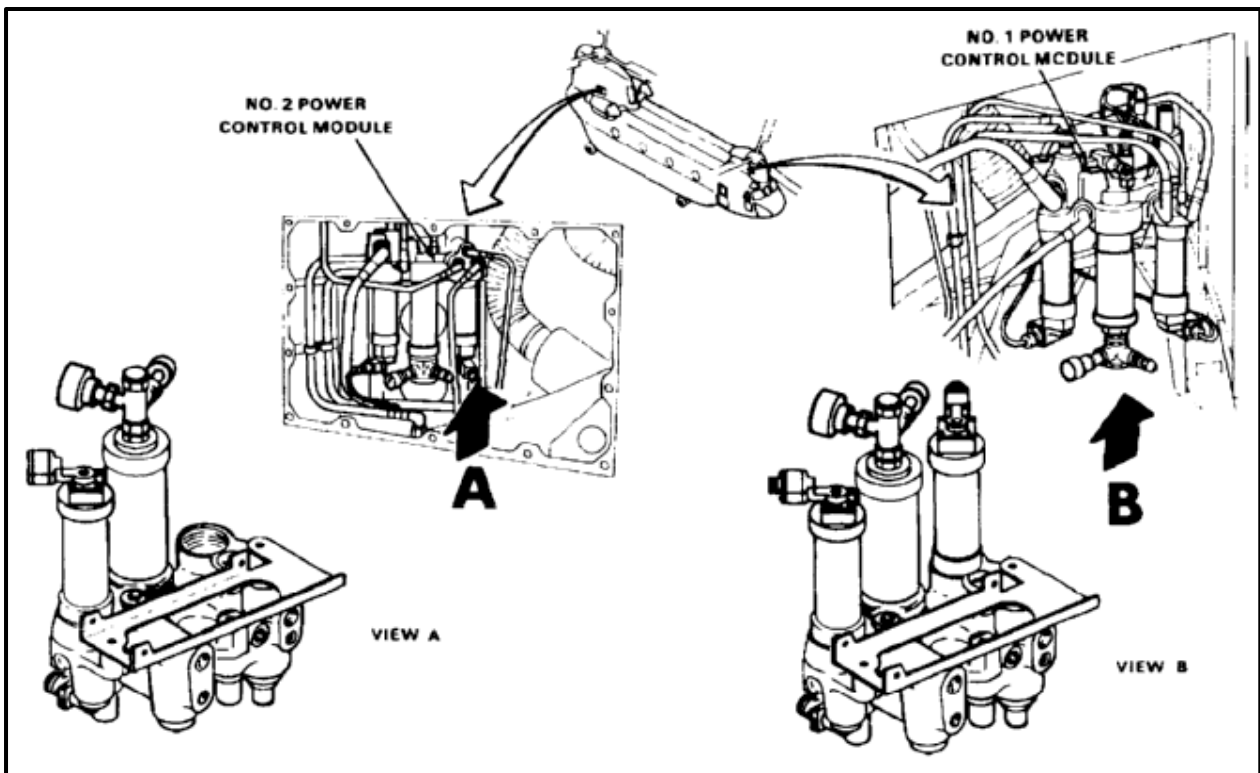

7-40 INSTALL NO. 1 OR NO. 2 POWER CONTROL MODULE HIGH PRESSURE RELIEF VALVE (Continued)

7-40

TO INSTALL RELIEF VALVE IN NO. 1 MODULE

1. Install packing (1), two retainers (2), and packing (3) on valve (4).
2. Install valve (4) in module (5) by turning nut (6).
3. Lockwire valve (4). Use lockwire (E231).

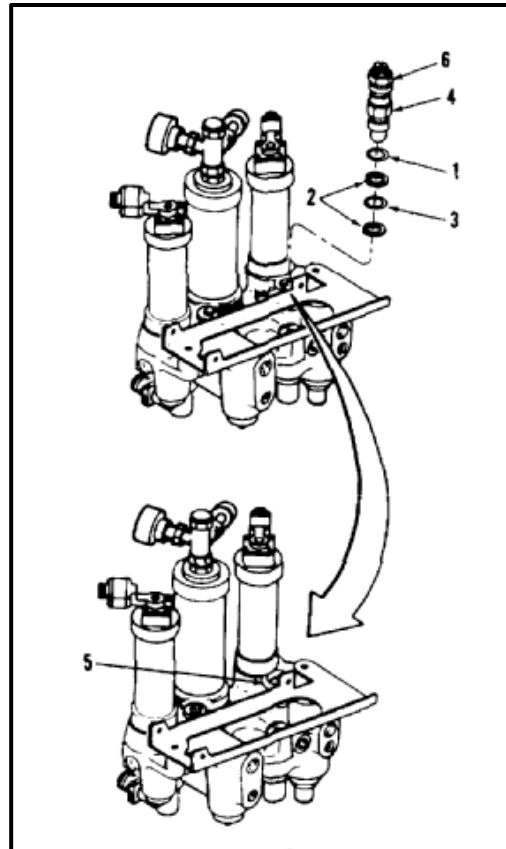
INSPECT

TO INSTALL RELIEF VALVE IN NO. 2 MODULE

4. Install packing (7), two retainers (8), and packing (9) on valve (10).
5. Install valve (10) in module (11) by turning nut (12).
6. Lockwire valve (10). Use lockwire (E231).

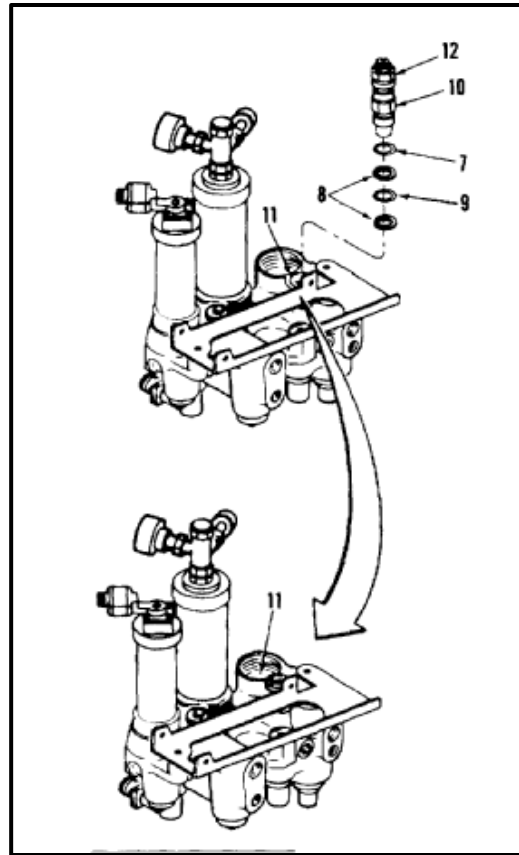

7-40 INSTALL NO. 1 OR NO. 2 POWER CONTROL MODULE HIGH PRESSURE RELIEF VALVE (Continued)

7-40

7. Install bowl (13) in port (14). Tighten hand tight.
8. Install two screws (15) in switch (16).
9. Connect connector (17) to switch (16).
10. Lockwire bowl (13) to module (18). Use lockwire (E231).

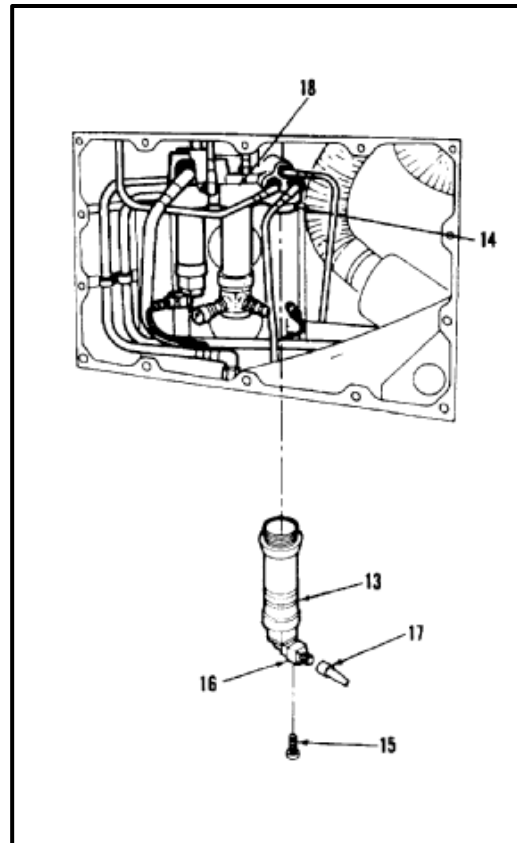
INSPECT**FOLLOW-ON MAINTENANCE:**

Perform operational check (TM 55-1520-240-T).
Close left forward work platforms or right pylon
access door (Task 2-2).

END OF TASK

INITIAL SETUP

General Safety Instructions:

Applicable Configurations:

All

Tools:

Aircraft Mechanic's Tool Kit, NSN 5180-00-323-4692
Strap Wrench

Materials:

Cloths (E135)
Gloves (E184.1)

Personnel Required:

Medium Helicopter Repairer

References:

Task 1-64

Equipment Condition:

Battery Disconnected (Task 1-39)
Electrical Power Off
Hydraulic Power Off
Left Forward Work Platform or Right Pylon Access
Door Open (Task 2-2)

WARNING

Hydraulic fluid (E199) is toxic. It can irritate skin and cause burns. Avoid inhaling. Use only with adequate ventilation. Avoid contact with skin, eyes, or clothing. In case of contact, immediately flush skin or eyes with water for at least **15 minutes**. Get medical attention for eyes.

WARNING

Deplete hydraulic pressure in system before disconnecting any fitting. Hydraulic fluid ejected under pressure can cause injury to personnel. Hydraulic fluid sprayed into the air is a fire hazard.

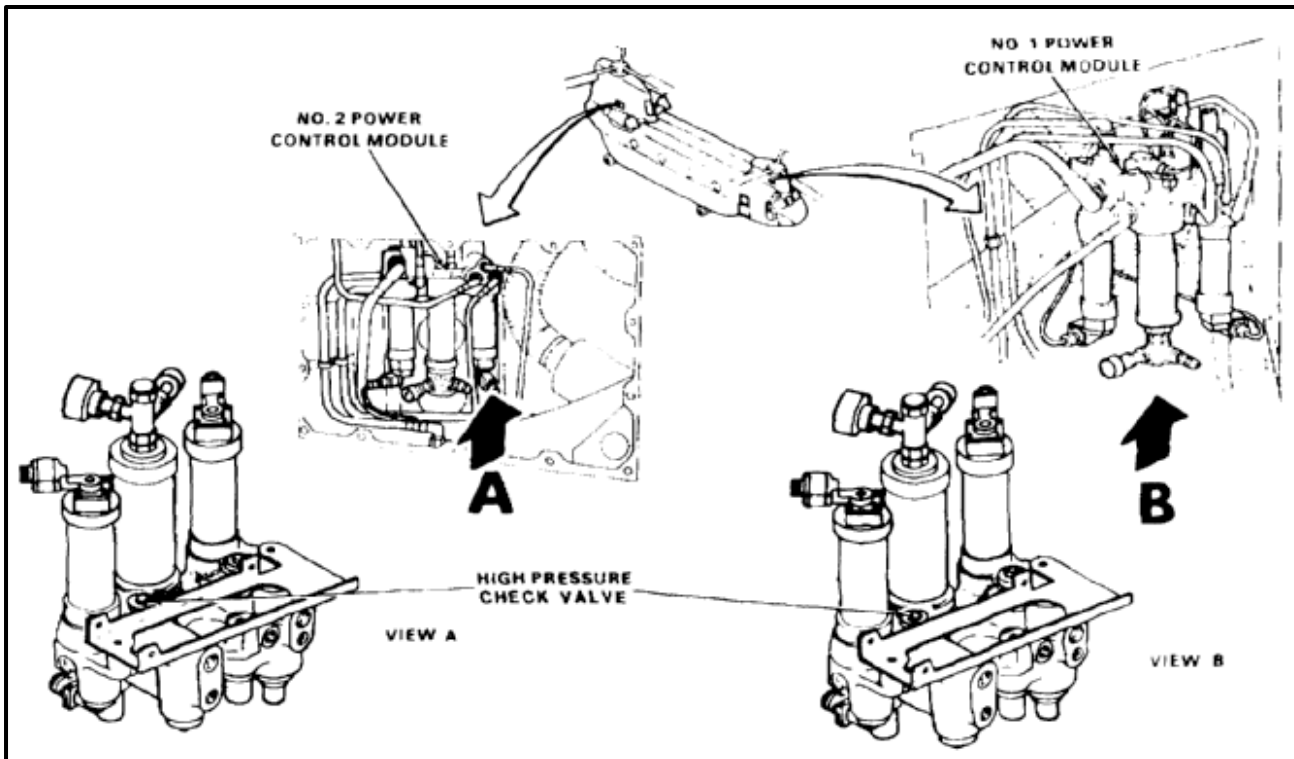

7-40.1 REMOVE NO. 1 OR NO. 2 POWER CONTROL MODULE HIGH PRESSURE CHECK VALVE (Continued)

7-40.1

NOTE

Deplete pressure in system by cycling cockpit control stick (Task 1-64).

1. Disconnect connector (1) from switch (2).
2. Remove two screws (3) from switch (2).
3. Remove lockwire from bowl (4). Remove bowl from module (5). Use cloths (E135) for spilled fluid. Wear gloves (E184.1). Use strap wrench.

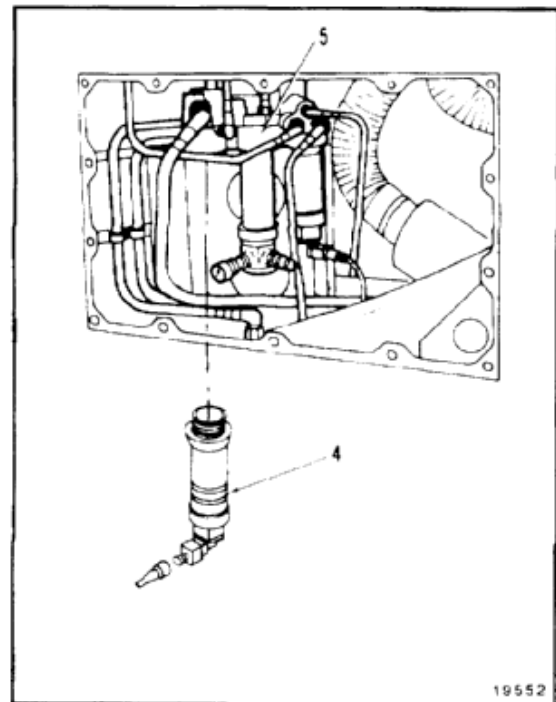
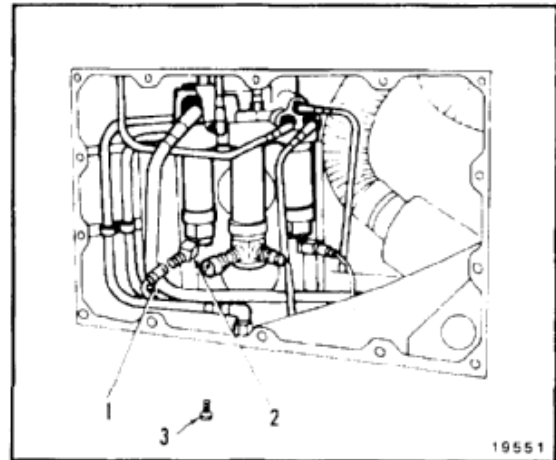

7-40.1 REMOVE NO. 1 OR NO. 2 POWER CONTROL MODULE HIGH PRESSURE CHECK VALVE (Continued)

7-40.1

4. Remove lockwire from valve (6).
5. Remove valve (6) from module (5). Use cloths (E135) for spilled fluid. Wear gloves (E184.1).
6. Remove two back-up rings (7), and packing (8) from valve (6).
7. Remove two retainers (9), and packing (9.1) from valve (6).

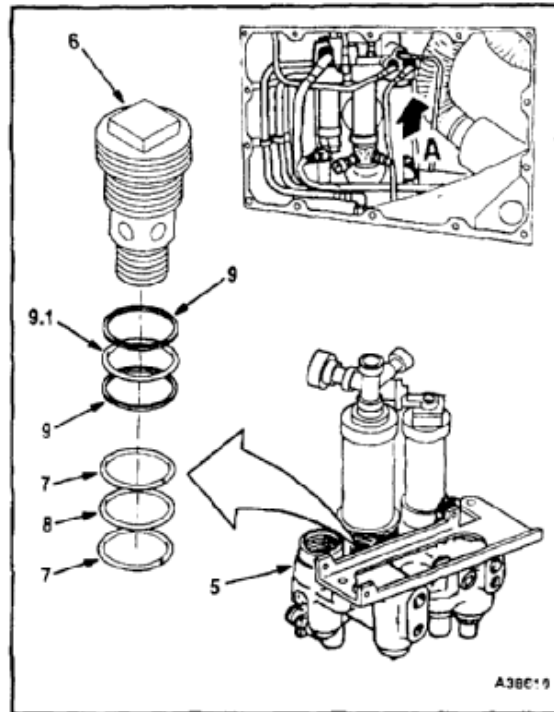
**FOLLOW-ON MAINTENANCE:**

None

END OF TASK

7-206

7-40.2 INSTALL NO. 1 OR NO. 2 POWER CONTROL MODULE HIGH PRESSURE CHECK VALVE

7-40.2

INITIAL SETUP

Applicable Configurations:

All

Tools:

Aircraft Mechanic's Tool Kit, NSN 5180-00-323-4692
 Box Wrench, 13/16 Inch
 Container, 2 Quart

Materials:

Lockwire (E231)

Parts:

Back-up Rings
 Preformed Packings
 Retainers

Personnel Required:

Medium Helicopter Repairer
 Inspector

References:

TM 55-1520-240-23P

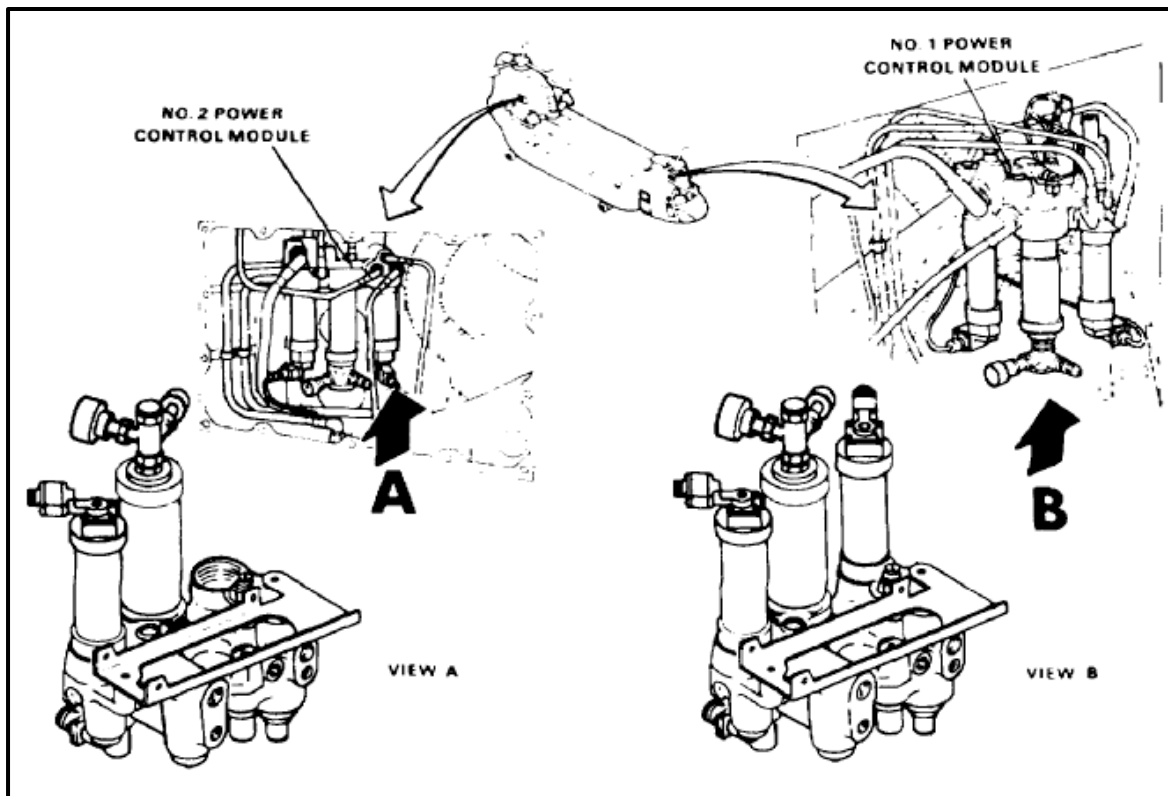

7-40.2 INSTALL NO. 1 OR NO. 2 POWER CONTROL MODULE HIGH PRESSURE CHECK VALVE (Continued)

1. Install two retainers (1), and packing (2), on valve (3).
2. Install two back-up rings (4), and packing (5), on valve (3).
3. Install valve (3) in module (6).
4. Lockwire valve (3). Use lockwire (E231).

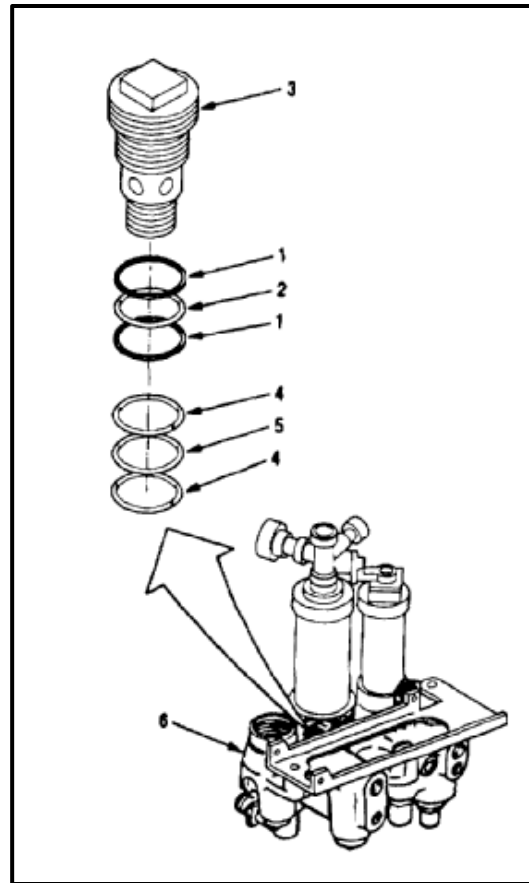

7-40.2 INSTALL NO. 1 OR NO. 2 POWER CONTROL MODULE HIGH PRESSURE CHECK VALVE (Continued)

7-40.2

5. Install bowl (7) in port (8). Tighten hand tight.
6. Install two screws (9) in switch (10).
7. Connect connector (11) to switch (10).
8. Lockwire bowl (7) to module (6). Use lockwire (E231).

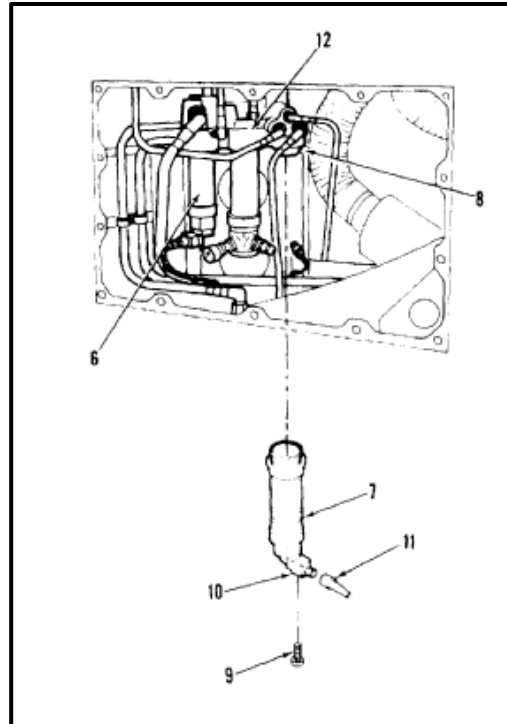
INSPECT**FOLLOW-ON MAINTENANCE:**

- Perform operational check (TM 55-1520240-T).
Close left forward work platforms or right pylon access door (Task 2-2).

END OF TASK

INITIAL SETUP

Applicable Configurations:

All

Tools:

Aircraft Mechanic's Tool Kit, NSN 5180-00-323-4692
 Container, 2 Quart

Materials:

Cloths (E120)
 Gloves (E186)

Personnel Required:

Medium Helicopter Repairer

Equipment Condition:

Battery Disconnected (Task 1-39)
 Electrical Power Off
 Hydraulic Power Off
 Right Forward Work Platform or Right Pylon Access
 Door Open (Task 2-2)

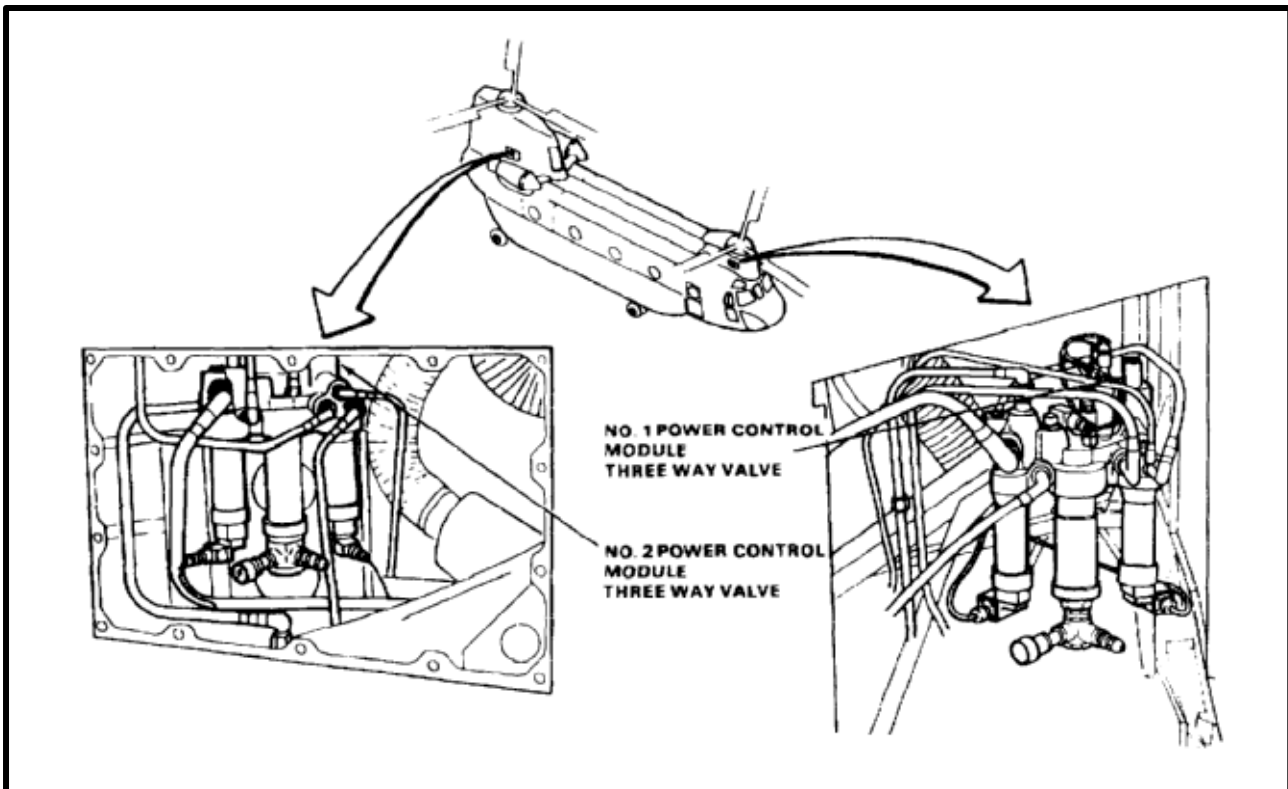

NOTE

Procedure is same to remove No. 1 or No. 2 module three way valves. No. 1 module three way valve is shown here.

Do not use vise grips or adjustable pliers to remove valve.

1. Remove lockwire from valve (1). Remove valve from module (2). Use a container and cloths (E135) for any spilled fluid. Use gloves (E186).

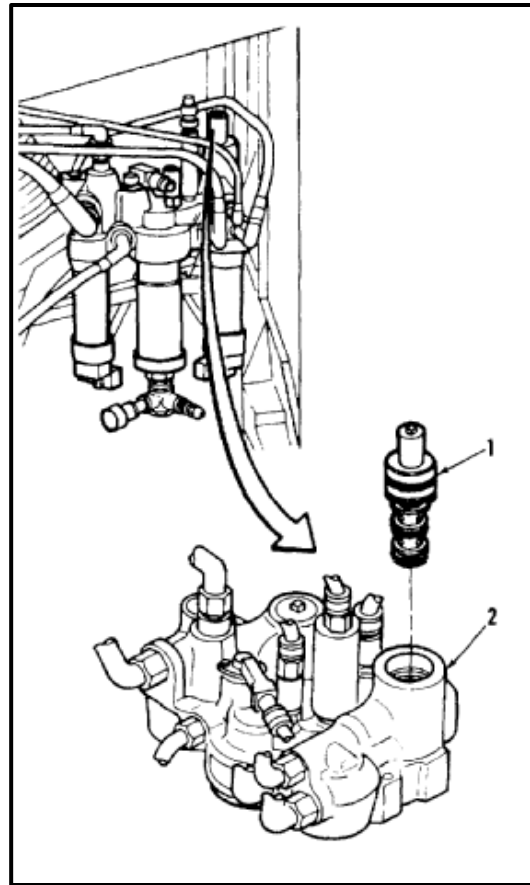
**FOLLOW-ON MAINTENANCE:**

None

END OF TASK

INITIAL SETUP

Applicable Configurations:

All

Tools:

Aircraft Mechanic's Tool Kit, NSN 5180-00-323-4692
 Torque Wrench, 100 to 750 Inch-Pounds
 Container, 2 Quart

Materials:

Lockwire (E230)
 Hydraulic Fluid (E199)
 Gloves (E184.1)

Parts:

None

Personnel Required:

Medium Helicopter Repairer
 Inspector

References:

TM 55-1520-240-23P
 Task 7-42.1

General Safety Instructions:

WARNING

Hydraulic fluid (E199) is toxic. It can irritate skin and cause burns. Avoid inhaling. Use only with adequate ventilation. Avoid contact with skin, eyes, or clothing. In case of contact, immediately flush skin or eyes with water for at least **15 minutes**. Get medical attention for eyes.

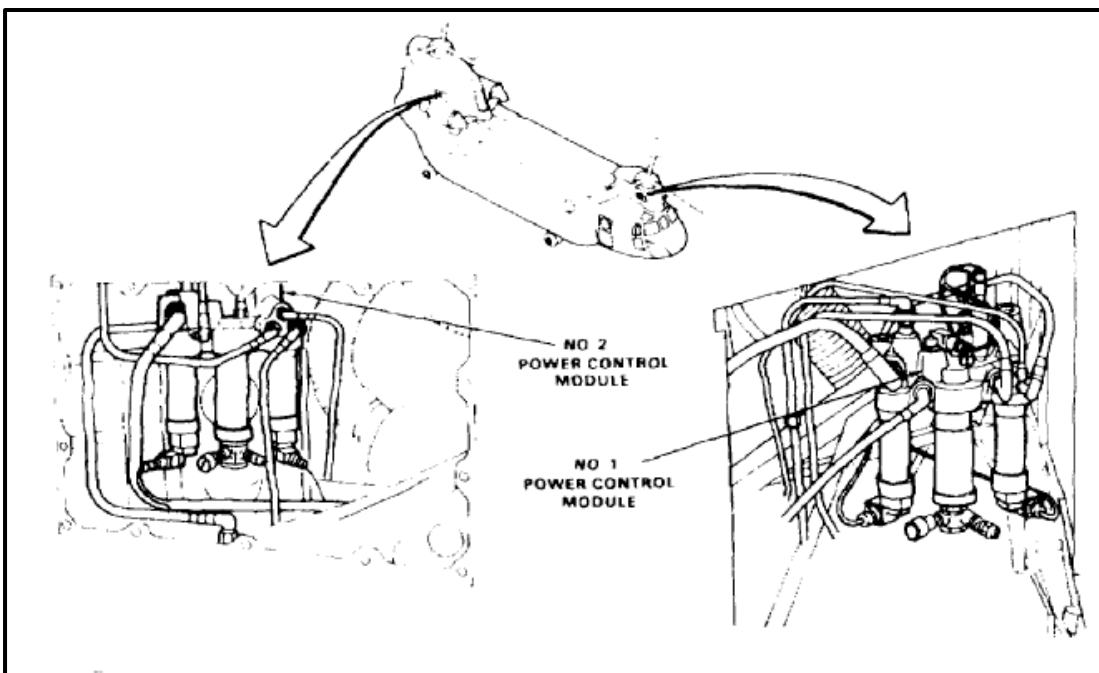

NOTE

There are two 3-way valves, one in No. 1 and one in No. 2 module. Procedure is same to install any 3-way valve. No. 1 module is shown here.

1. Inspect valve (1) for damaged, protruding, or oversized packings and packing retainers (Task 7-42.1).
2. Coat installed seals (2) with hydraulic fluid (E199). Wear gloves (E184.1).



Do not force or cock valve during installation. Any sudden resistance or increase in torque may be the result of damaged packings or packing retainers. Remove valve and reinspect (Task 7-42.1).

NOTE

Do not use vise grips or adjustable pliers to install valve.

3. Gently install valve (1) in port (3). Use hand pressure and rotate slowly allowing valve to seat itself. Engage thread and hand tighten as far as possible.
4. Torque valve with sufficient force to insure proper seating of valve. Do not exceed **180 inch-pounds**.
5. Lockwire valve (1) to valve (4). Use lockwire (E230).

INSPECT**FOLLOW-ON MAINTENANCE:**

Perform operational check (TM 55-1520-240-T). Close right forward work platform or right pylon access door (Task 2-2).

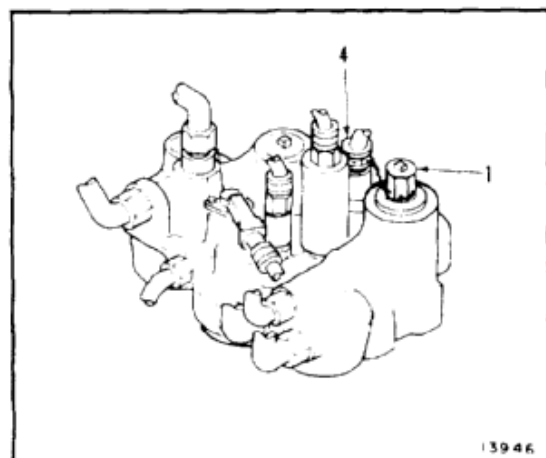
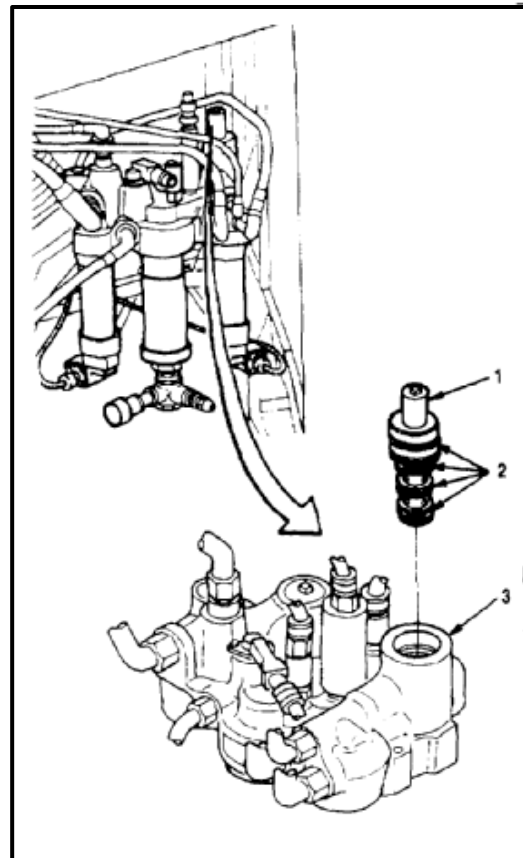

13946

END OF TASK

INITIAL SETUP

Applicable Configurations:

All

Tools:

As Required

Materials:

None

Parts:Preformed Packings
Packing Retainers**Personnel Required:**Medium Helicopter Repairer
Inspector**Equipment Condition:**

Off Helicopter Task

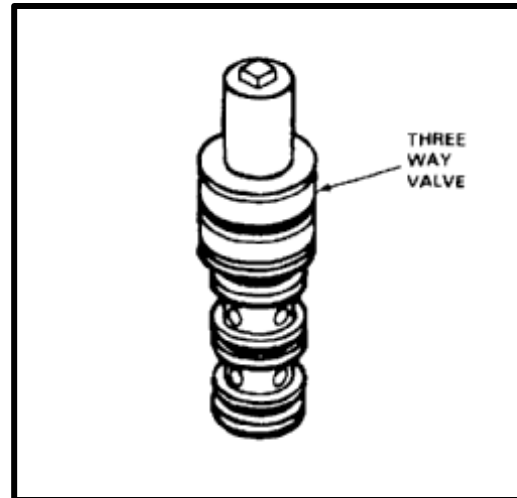

Three-way valve contains three packing/packing retainer sets which appear to be the same size but are not. Ensure valve has correct size packing/packing retainers in each location. Incorrect size packing/packing retainers may cause failure of the flight boost system.

NOTE

Repair of three-way valve consists of replacement of packing and packing retainers only.

7-42.1 INSPECT AND REPAIR NO. 1 OR NO. 2 POWER CONTROL MODULE THREE-WAY VALVE (Continued)

7-42.1

1. Inspect valve (1) for damaged, protruding, or incorrect size packings and packing retainers.
2. Replace packings (3, 5, 7, and 9) and/or packing retainers (2, 4, 6, and 8) as required.

PART		INDEX
MS28774-129	Retainer	2
MS28775-129	Packing	3
MS28774-122	Retainer	4
MS28775-122	Packing	5
MS28774-121	Retainer	6
MS28775-121	Packing	7
MS28774-120	Retainer	8
MS28775-120	Packing	9

INSPECT

FOLLOW-ON MAINTENANCE:

None

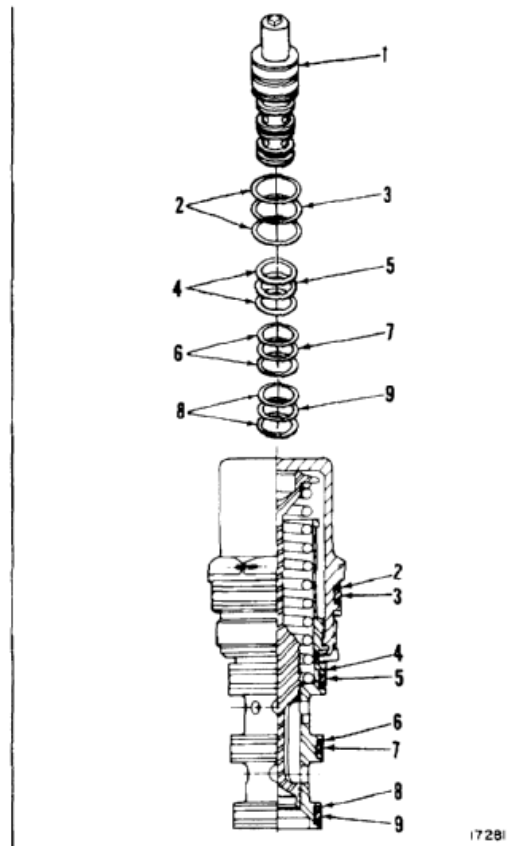

17281

END OF TASK

INITIAL SETUP

General Safety Instructions:

Applicable Configurations:

All

Tools:

Aircraft Mechanic's Tool Kit, NSN 5180-00-323-4692

Materials:

Cloths (E135)
Gloves (E186)

Personnel Required:

Medium Helicopter Repairer

Equipment Condition:

Battery Disconnected (Task 1-39)
Electrical Power Off
Hydraulic Power Off
Right Forward Work Platform or Right Pylon Access
Door Open (Task 2-2)

WARNING

Hydraulic fluid (E199) is toxic. It can irritate skin and cause burns. Avoid inhaling. Use only with adequate ventilation. Avoid contact with skin, eyes, or clothing. In case of contact, immediately flush skin or eyes with water for at least **15 minutes**. Get medical attention for eyes.

WARNING

Hydraulic fluid ejected under pressure can cause injury to personnel. Hydraulic fluid sprayed into the air is a fire hazard.

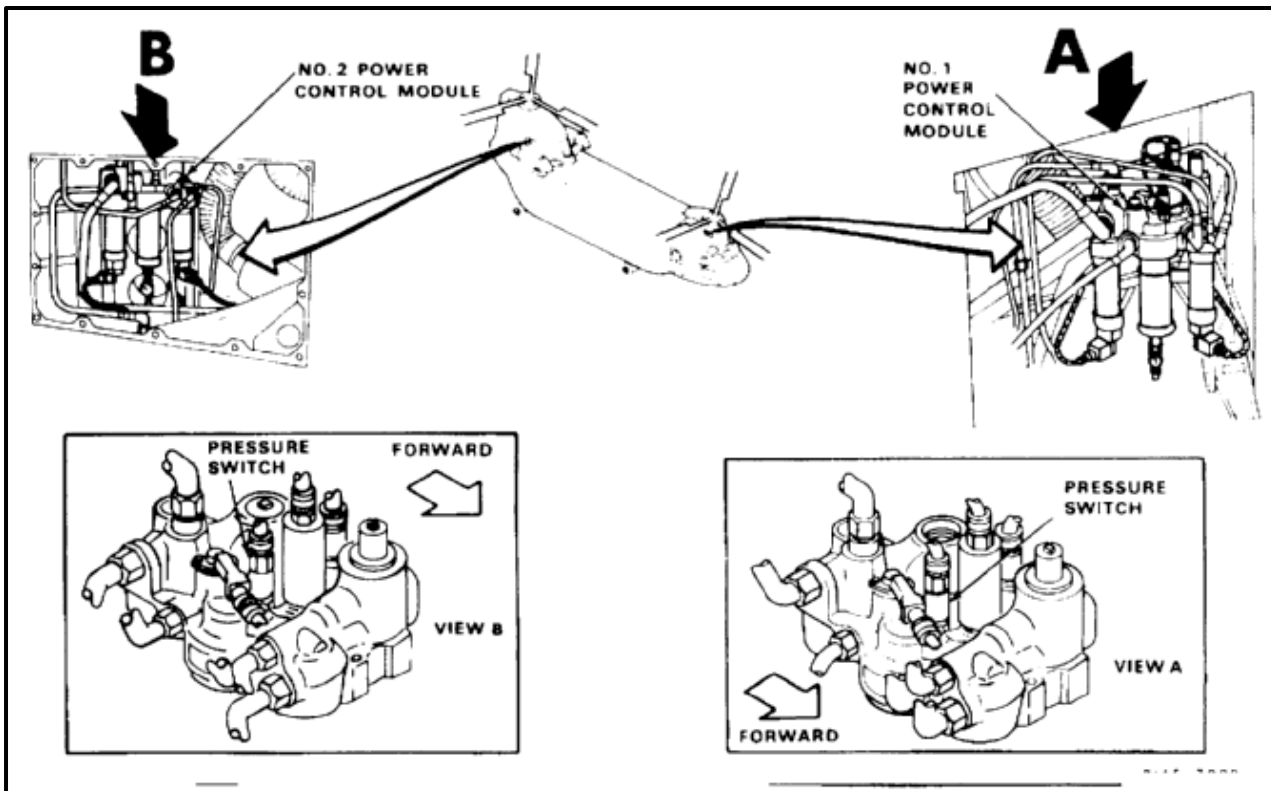

NOTE

There are two pressure switches, one in No. 1 and one in No. 2 module. Procedure is same to remove any pressure switch. No. 1 module is shown here.

1. Disconnect connector (1) from switch (2).
2. Remove switch (2) and packing (3) from SYS PRESS SW port (4). Use cloths (E135) for spilled fluid. Use gloves (E186).

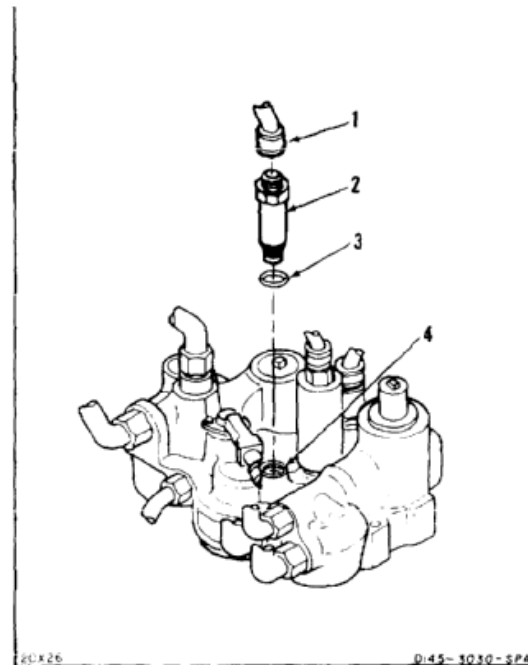
**FOLLOW-ON MAINTENANCE:**

None

END OF TASK

INITIAL SETUP

Applicable Configurations:

All

Tools:

Aircraft Mechanic's Tool Kit, NSN 5180-00-323-4692

Materials:

Lockwire (E231)

Parts:

Preformed Packing

Personnel Required:

Medium Helicopter Repairer
Inspector

References:

TM 55-1520-240-23P

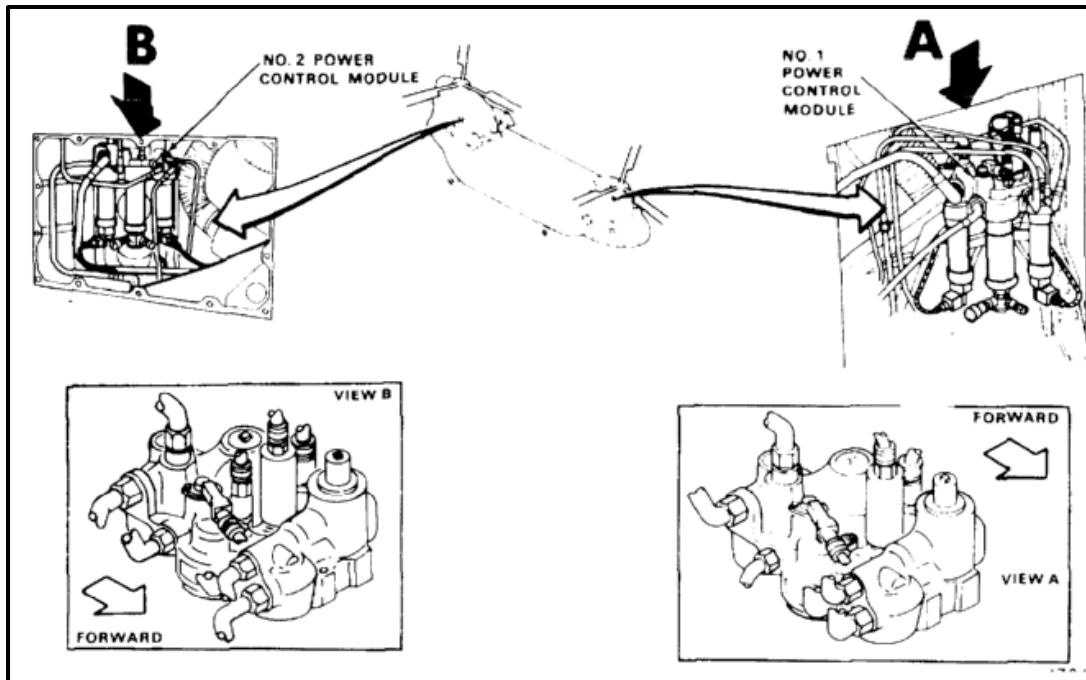

NOTE

There are two pressure switches, one in No. 1 and one in No. 2 module. Procedure is same to install any pressure switch. No. 1 module is shown here.

1. Install switch (1) and packing (2) in SYS PRESS SW port (3).
2. Lockwire switch (1) to pressure transmitter (4). Use lockwire (E231).
3. Connect connector (5) to switch (1).

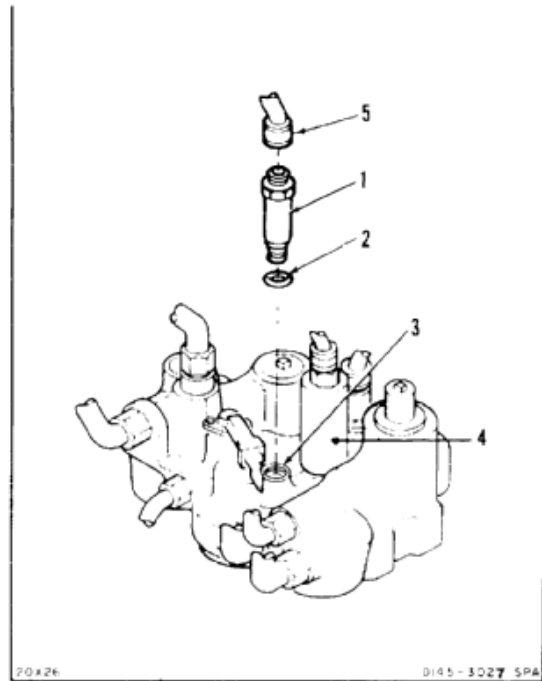
INSPECT**FOLLOW-ON MAINTENANCE:**

Service flight control system (Task 1-62 or 1-63).
 Perform operational check (TM 55-1520-240-T).
 Close right forward work platform or right pylon access door (Task 2-2).

END OF TASK

INITIAL SETUP

Applicable Configurations:

All

Tools:

Aircraft Mechanic's Tool Kit, NSN 5180-00-323-4692

Materials:

Cloths (E135)
Gloves (E184.1)

Personnel Required:

Medium Helicopter Repairer

Equipment Condition:

Battery Disconnected (Task 1-39)
Electrical Power Off
Hydraulic Power Off
Right Forward Work Platform or Pylon Right Access
Door Open (Task 2-2)

General Safety Instructions:

WARNING

Hydraulic fluid (E199) is toxic. It can irritate skin and cause burns. Avoid inhaling. Use only with adequate ventilation. Avoid contact with skin, eyes, or clothing. In case of contact, immediately flush skin or eyes with water for at least **15 minutes**. Get medical attention for eyes.

WARNING

Hydraulic fluid ejected under pressure can cause injury to personnel. Hydraulic fluid sprayed into the air is a fire hazard.

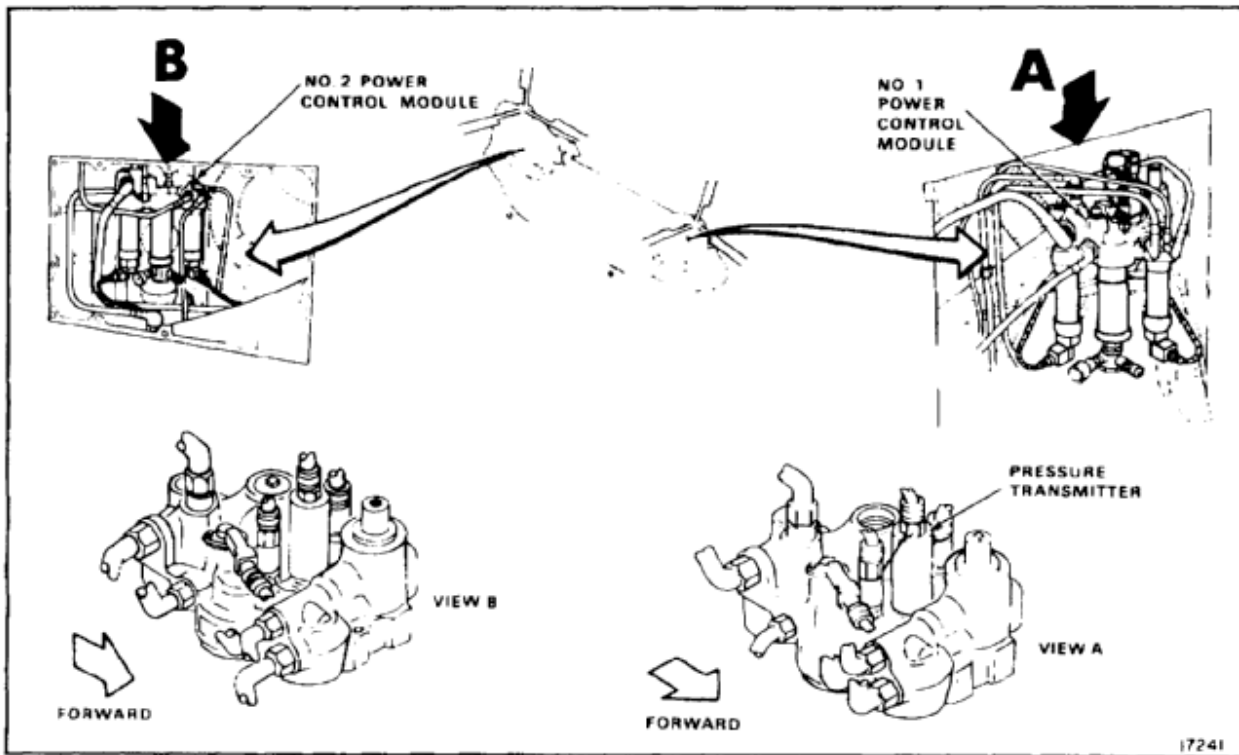

7-45 REMOVE NO. 1 OR NO. 2 POWER CONTROL MODULE PRESSURE TRANSDUCER (Continued)

7-45

NOTE

There are two pressure transmitters, one in No. 1 and one in No. 2 module. Procedure is same to remove any pressure transmitter. No. 1 module is shown here.

1. Remove lockwire and disconnect connector (1) from transmitter (2).
2. Remove transmitter (2) and packing (3) from PRESS XMTR port (4). Use cloths (E135) for spilled fluid. Wear gloves (E184.1).

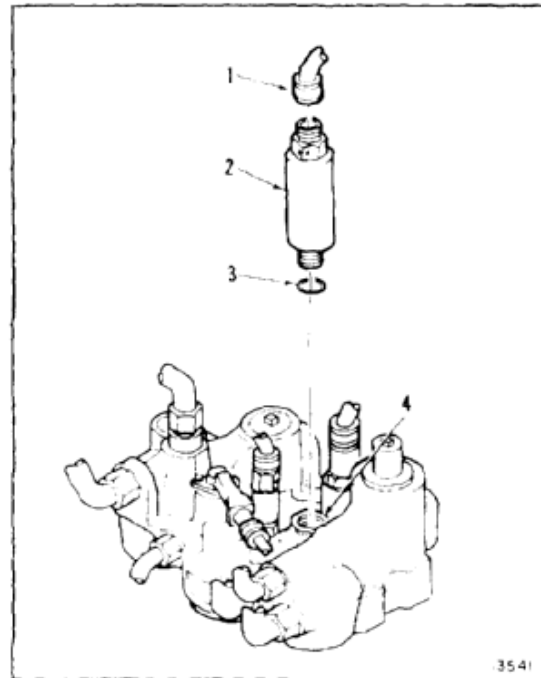
**FOLLOW-ON MAINTENANCE:**

None

END OF TASK

INITIAL SETUP

Applicable Configurations:

All

Tools:

Aircraft Mechanic's Tool Kit, NSN 5180-00-323-4692

Materials:

Lockwire (E231)

Parts:

Preformed Packing

Personnel Required:

Medium Helicopter Repairer
Inspector

References:

TM 55-1520-240-23P

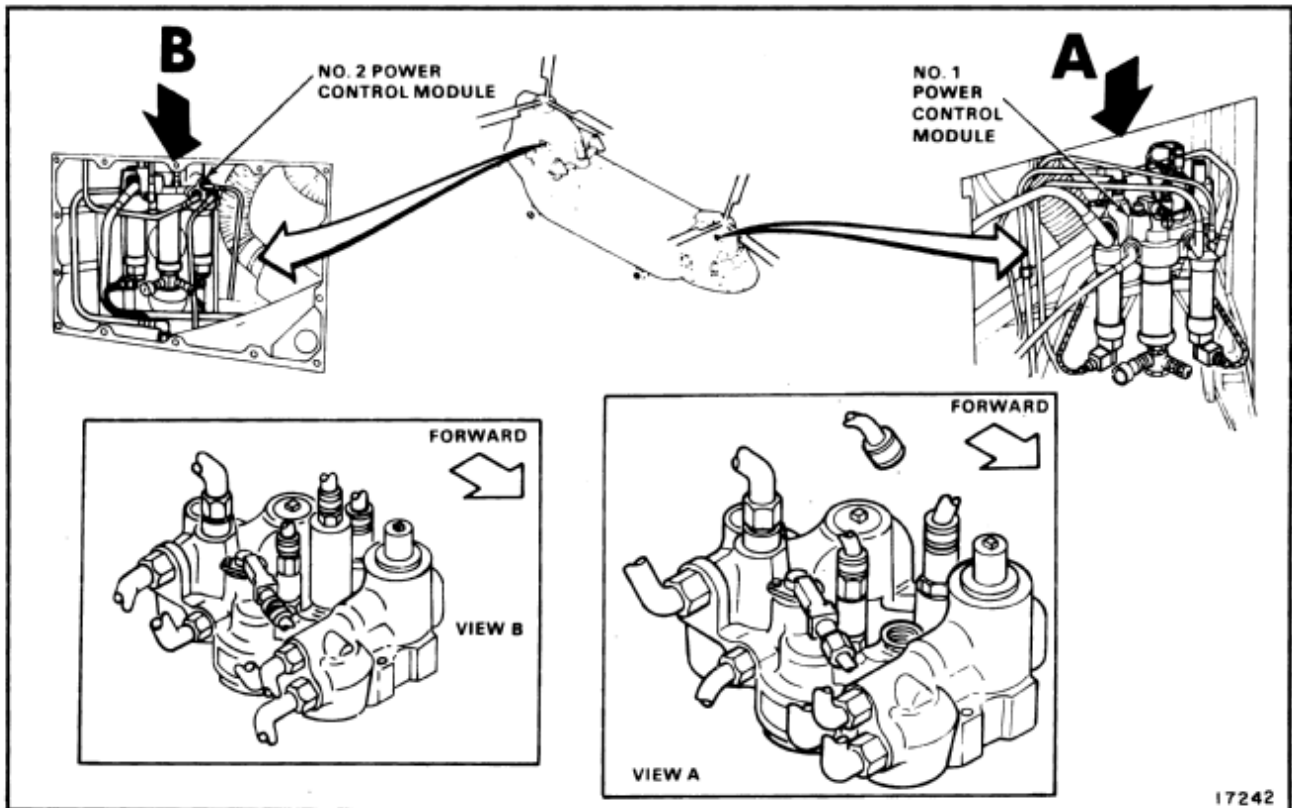

7-46 INSTALL NO. 1 OR NO. 2 POWER CONTROL MODULE PRESSURE TRANSDUCER (Continued)

7-46

NOTE

There are two pressure transmitters, one in No. 1 and one in No. 2 module. Procedure is same to install any pressure transmitter. No. 1 module is shown here.

1. Install transmitter (1) and packing (2) in PRESS XMTR port (3).
2. Lockwire transmitter (1) to pressure switch (4). Use lockwire (E231).
3. Connect connector (5) to transmitter (1).

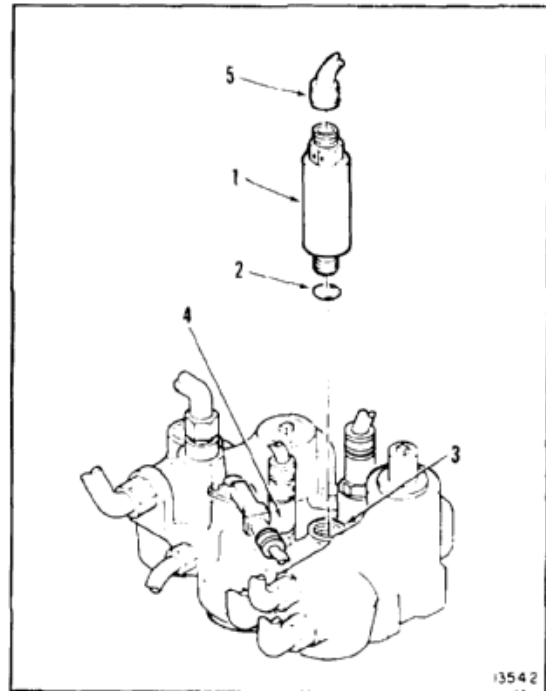
INSPECT**FOLLOW-ON MAINTENANCE:**

Service flight control system (Task 1-62 or 1-63).
 Perform operational check (TM 55-1520-240-T).
 Close right forward work platform or install aft pylon access door (Task 2-2).

END OF TASK

INITIAL SETUP

Applicable Configurations:

All

Tools:

Aircraft Mechanic's Tool Kit, NSN 5180-00-323-4692
 Open End Wrench, 1 Inch
 Strap Wrench
 Open End Wrench, 2-1/2 Inch

Materials:

Cloths (E135)
 Gloves (E186)

Personnel Required:

Medium Helicopter Repairer

Equipment Condition:

Battery Disconnected (Task 1-39)
 Electrical Power Off
 Hydraulic Power Off
 No. 1 or No. 2 Flight Control Module
 Accumulator (Air Charge) Depressurized (Task 1-63)
 Right Forward Work Platform Open or Right Pylon
 Access Door Removed (Task 2-2)

General Safety Instructions:**WARNING**

Hydraulic fluid (E199) is toxic. It can irritate skin and cause burns. Avoid inhaling. Use only with adequate ventilation. Avoid contact with skin, eyes, or clothing. In case of contact, immediately flush skin or eyes with water for at least **15 minutes**. Get medical attention for eyes.

WARNING

Hydraulic fluid ejected under pressure can cause injury to personnel. Hydraulic fluid sprayed into the air is a fire hazard.

WARNING

Release gas and fluid pressures before disassembling, storing, or shipping accumulator. Maximum operating pressure is **3,350 psi**.

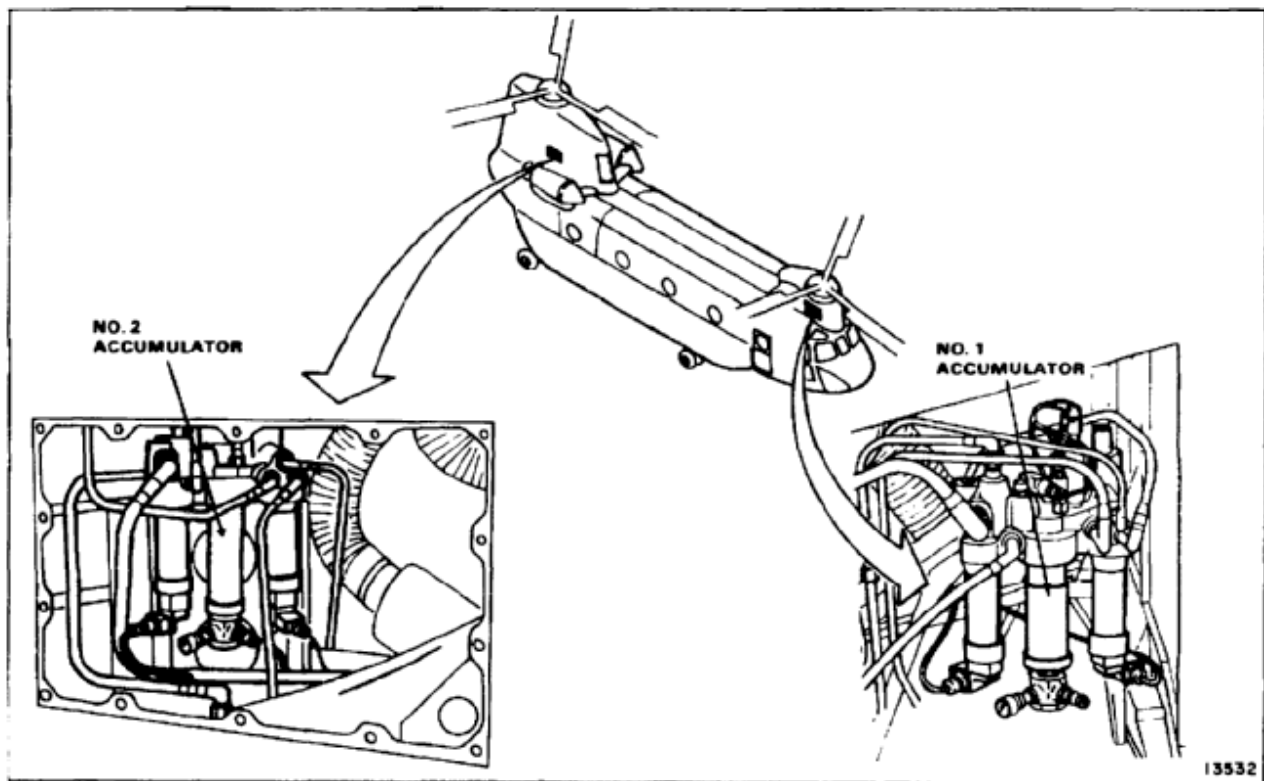

NOTE

There are two accumulators, one in No. 1 and one in No. 2 module. Procedure is same to remove any accumulator. No. 1 module is shown here.

1. Loosen nut (1) and remove gage (2) and packing (4) from fitting (5). Use cloths (E135) for spilled fluid. Use gloves (E186).

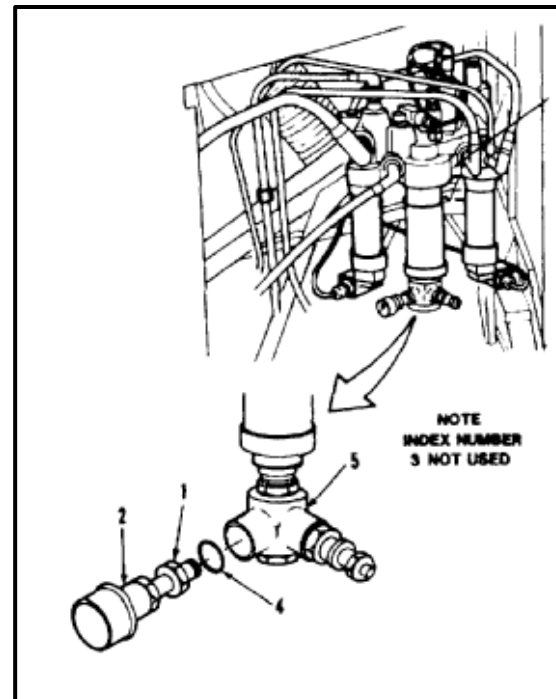

2. Remove lockwire from accumulator (6). Remove accumulator, two retainers (7), and packing (8) from module (9). Use **2-1/2 inches** open end wrench. Use cloths (E135) for spilled fluid.

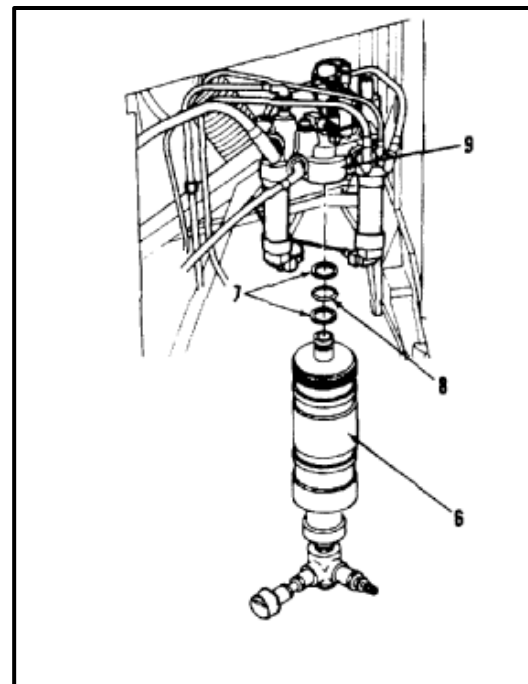

3. Remove lockwire from fitting (10).
4. Remove valve (10) and packing (11) from accumulator (6). Use cloths (E135) for spilled fluid.

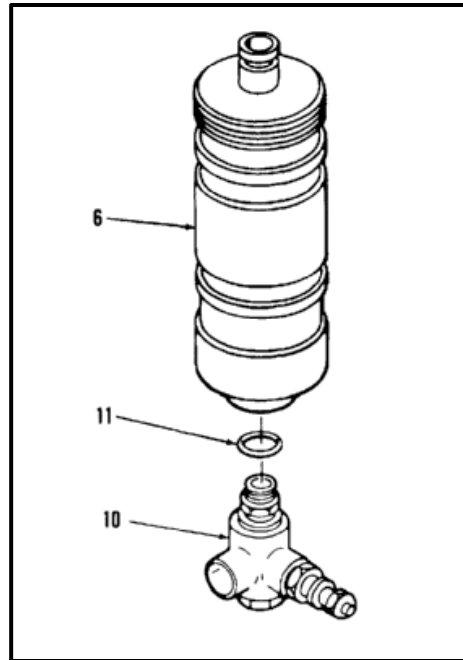
***FOLLOW-ON MAINTENANCE:***

None

END OF TASK

7-226

INITIAL SETUP

Applicable Configurations:

All

Tools:

Hydraulic Repairer's Tool Kit, NSN 5180-00-323-4891
 Strap Wrench, 1-5/16 to 5-9/16 Inch
 Heater Gun
 Soft Jawed Vise
 Technical Inspection Tool Kit, NSN 5180-00-323-5114
 Outside Micrometer Calipers, 1 to 2 Inch
 Telescoping Gage Set

Materials:

None

Personnel Required:

Machinist
 Aircraft Pneudraulics Repairer
 Inspector

Equipment Condition:

Off Helicopter Task

General Safety Instructions:**WARNING**

Release gas and fluid pressures before disassembling, storing, or shipping accumulator. Maximum operating pressure is **3,350 psi**.

NOTE

General inspection criteria (Task 7-1.1) for obvious damage applies unless otherwise stated.

Inspection steps cover parts that are subject to wear.

1. Remove lockwire from end cap (1) and nut (2).
2. Remove pin (3) from end cap (1) and nut (2).

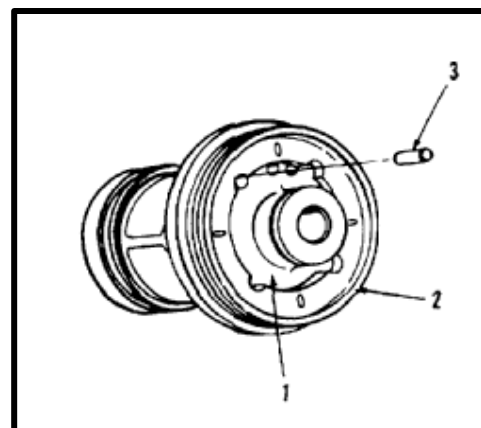
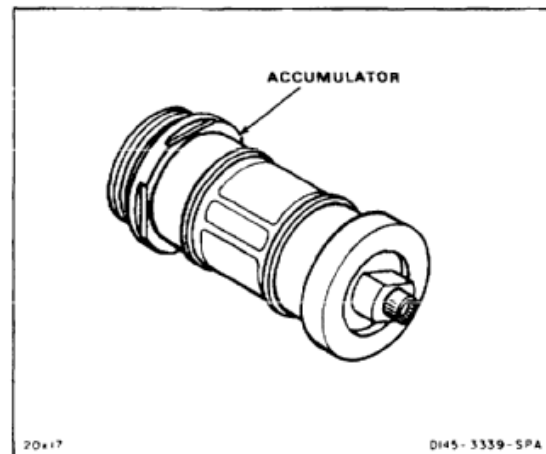

3. Install nut (2) in vise (4).
4. Remove shell (5) from nut (2). Turn shell counterclockwise.
5. Remove nut (2) from vise (4).

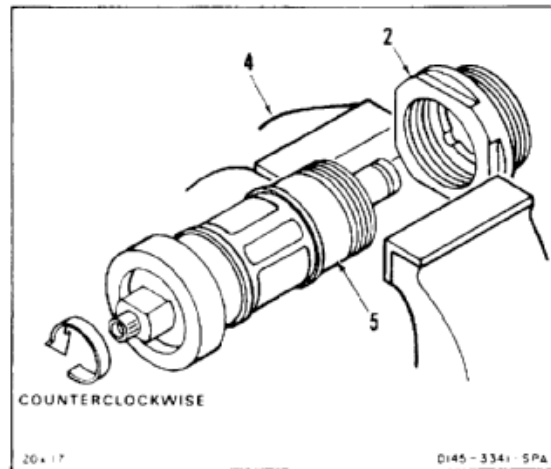

6. Remove end cap (1) from shell (5). Pull cap.
7. Remove packing (6) and retaining ring (7) from end cap (1).
8. Have machinist remove two pins (8).
- 8.1. Inspect lands (8.1) of end cap (1). There shall be no nicks or burrs.

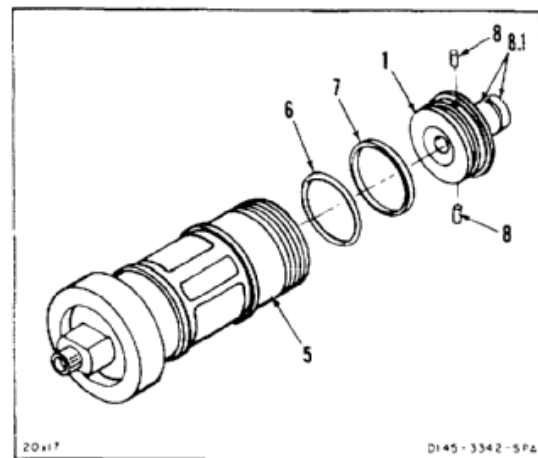

9. Remove lockwire from nut (9).
10. Install shell (5) in vise (4).
11. Remove nut (9) from shell (5). Use strap wrench.
12. Remove end cap (10) from shell (5). Pull cap.
13. Remove packing (11) and retaining ring (12) from end cap (10).
14. Have machinist remove two pins (13) from end cap (10).

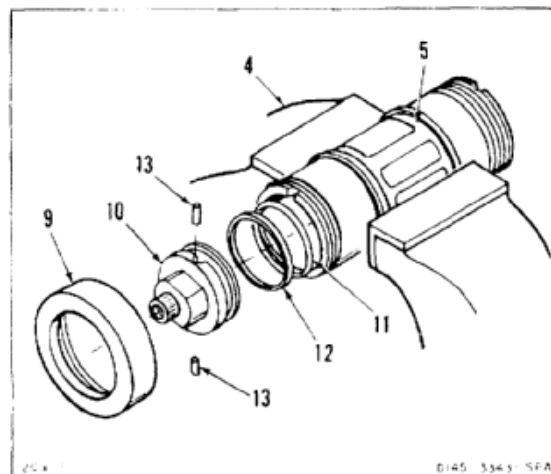

CAUTION

Do not damage cylinder walls when removing piston.

15. Remove piston (14) from shell (5). Lightly tap piston with hammer handle to remove.
16. Remove two Teflon rings (15) from piston (14).
17. Remove two retaining rings (16) and tee packing.
- 17.1. Measure outside diameter of piston (14) at four lands (17.1). Diameter shall not be less than **1.992 inches**.
18. Remove shell (5) from vise (4).
- 18.1. Measure inside diameter of shell (5). Diameter shall not be more than **2.000 inches**.
19. If nameplate (18) is damaged or shell (5) is to be replaced, remove nameplate and strap (19). Use heater gun.

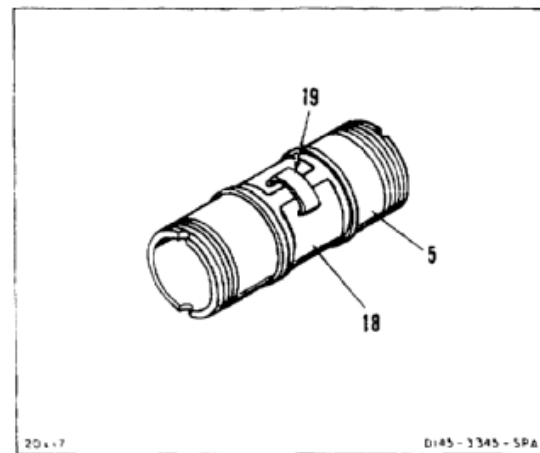
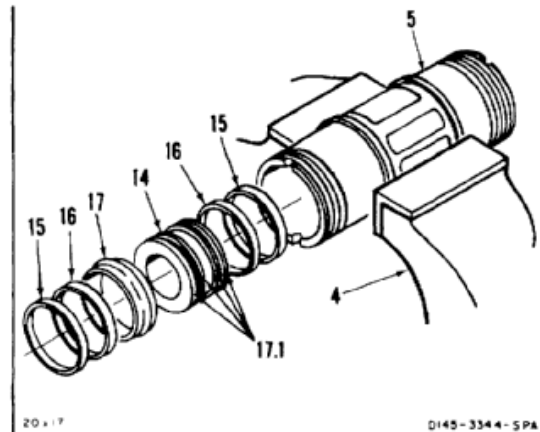

FOLLOW-ON MAINTENANCE:

None

END OF TASK

INITIAL SETUP

Applicable Configurations:

All

Tools:

Hydraulic Repairer's Tool Kit, NSN 5180-00-323-4891
 Wrench, 3/4 Inch Open End
 Wood Dowel, 3/8 X 6 Inches
 Soft Jawed Vise
 Technical Inspection Tool Kit, NSN 5180-00-323-5114
 Outside Micrometer Calipers, 1 to 2 Inch
 Telescoping Gage Set
 Goggles

Materials:

None

Personnel Required:

Aircraft Pnedraulics Repairer
 Inspector

Equipment Condition:

Off Helicopter Task

General Safety Instructions:**WARNING**

Release gas and fluid pressures before disassembling, storing, or shipping accumulator. Maximum operating pressure is **3,350 psi**.

NOTE

General inspection criteria (Task 7-1.1) for obvious damage applies unless otherwise stated.

Inspection steps cover parts that are subject to wear.

1. Install gas port end of accumulator (1) in vise (2).

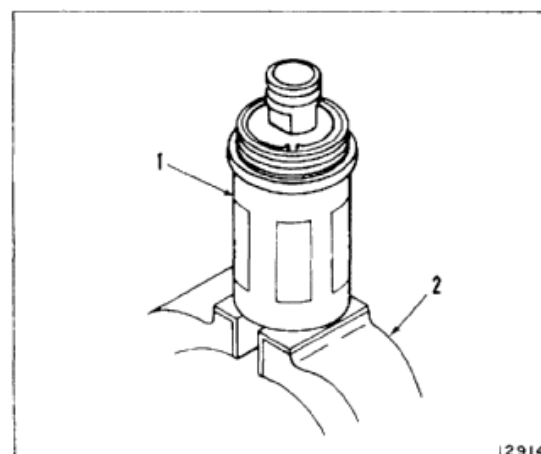
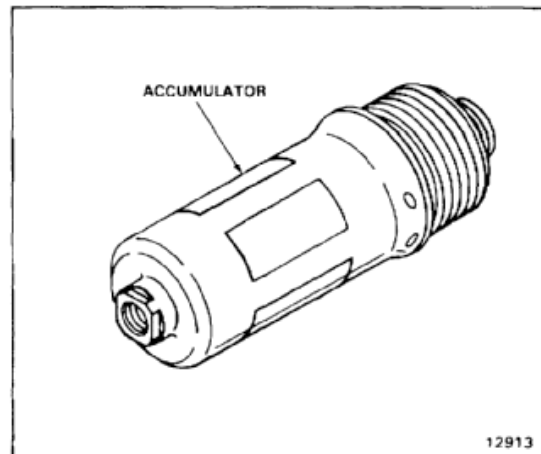

7-48.1 DISASSEMBLE AND INSPECT ACCUMULATOR (AD-A620-1D340) (AVIM) (Continued)

7-48.1

2. Remove spiral retaining ring (3) from housing (4).
3. Remove retainer (5) from housing (4).

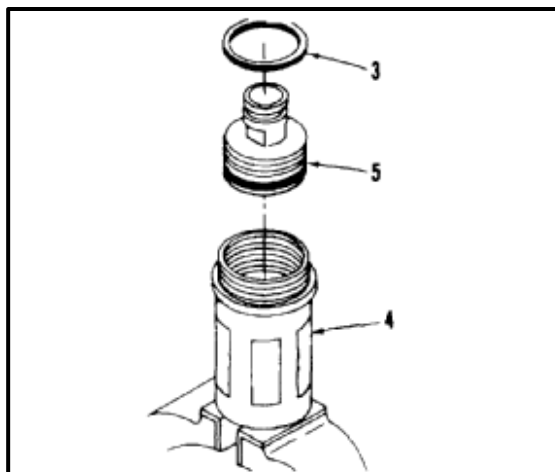

4. Remove packings (6 and 8) and retainer rings (7 and 9) from retainer (5).

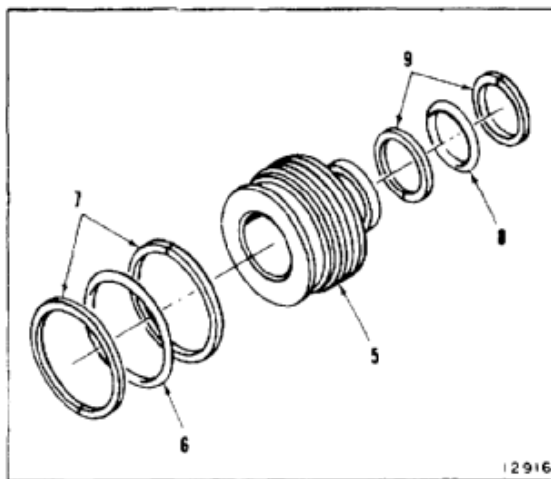

5. Remove housing (4) from vise (2).

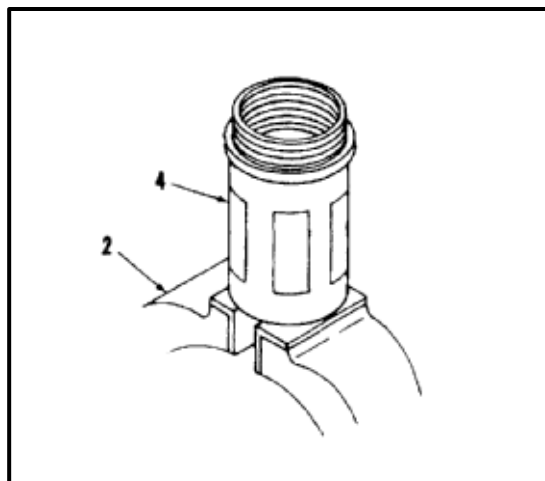

CAUTION

Use care to avoid damage to piston (11) when removing it from housing (4).

6. Remove piston (11) from housing (4). Use dowel (10) placed through gas port end of housing (4).

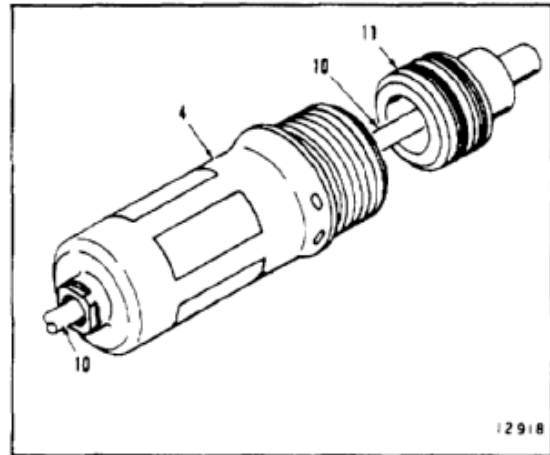

7. Remove packings (12) and retainer rings (13) from piston (11).
8. Measure outside diameter of piston (11) at three lands (14). Diameter shall not be less than **1.986 inches**.
9. Measure inside diameter of housing (4). Diameter shall not be more than **1.9940 inches**.
10. Inspect all parts for wear and damage (cracks, nicks, burrs, etc.). Carefully inspect inside wall of housing for scoring. Replace parts as required.

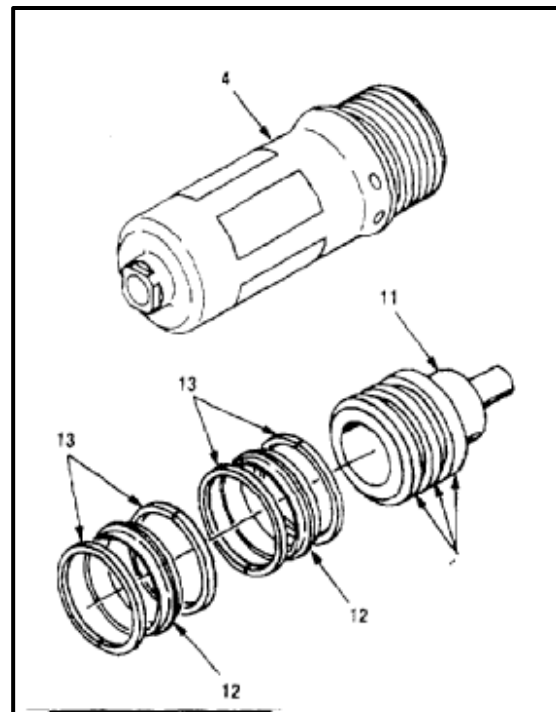

FOLLOW-ON MAINTENANCE:

None

END OF TASK

7-232

7-48.2 DISASSEMBLE AND INSPECT ACCUMULATOR (60910) (AVIM)

7-48.2

INITIAL SETUP**Applicable Configurations:**

All

Tools:

Hydraulic Repairer's Tool Kit, NSN 5180-00-323-4891
 Technical Inspection Tool Kit, NSN 5180-00-323-5114
 Outside Micrometer Calipers, 1 to 2 Inch
 Telescoping Gage Set
 Soft Jawed Vise

Materials:

None

Personnel Required:

Aircraft Pneudraulics Repairer
 Inspector

References:

Task 7-1.1

Equipment Condition:

Off Helicopter Task

General Safety Instructions:**WARNING**

Release gas and fluid pressures before disassembling, storing, or shipping accumulator. Maximum operating pressure is **3,350 psi**.

NOTE

General inspection criteria (Task 7-1.1) for obvious damage applies unless otherwise stated.

Inspection steps cover parts that are subject to wear.

1. Install gas port end of accumulator (1) in vise (2).

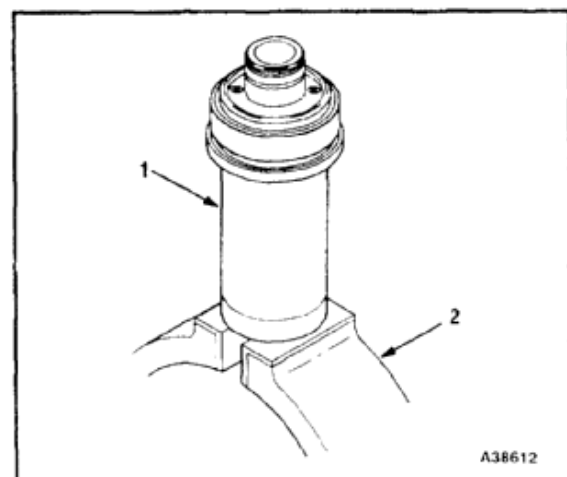
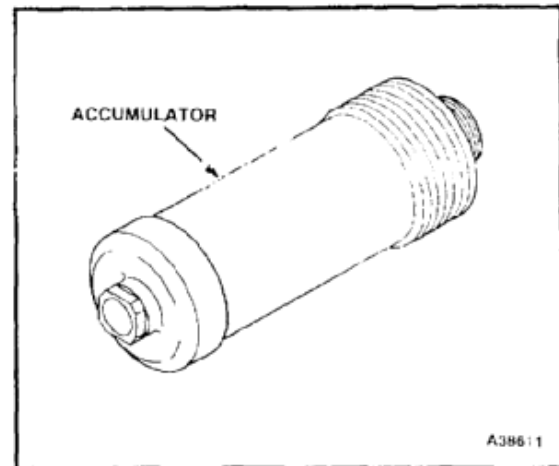

2. Remove screws (3) from plate (4).
3. Remove retainer ring (5) from housing (6).
4. Remove end cap (7) from housing (6).

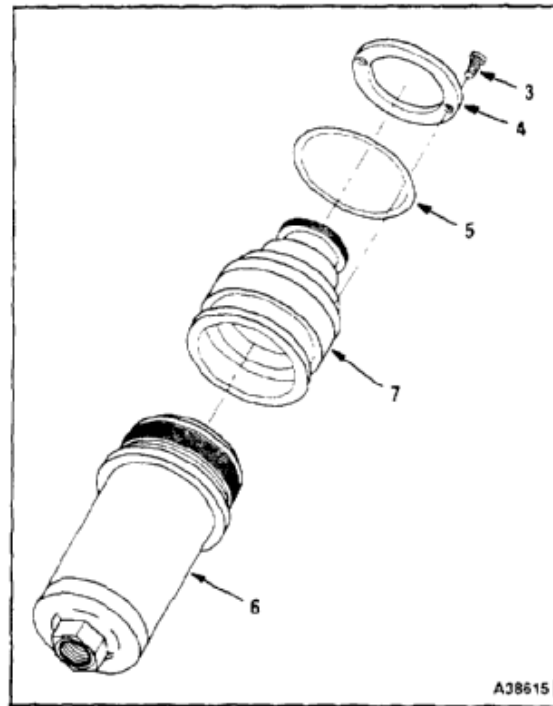

5. Remove packings (8 and 10) and retainer rings (9 and 11) from end cap (7).

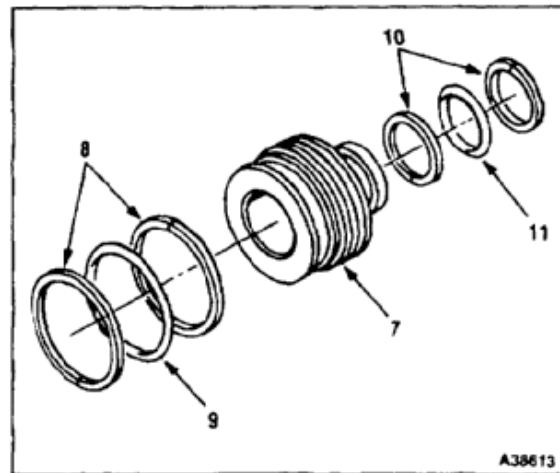

6. Remove housing (6) from vise (2).

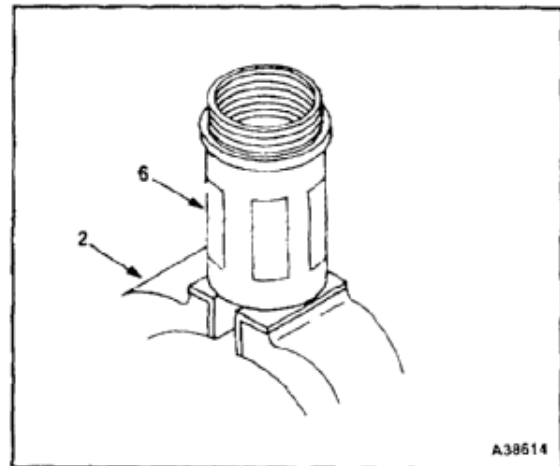

Use care to avoid damage to separator when removing it from housing.

7. Remove separator (12) from housing (6).

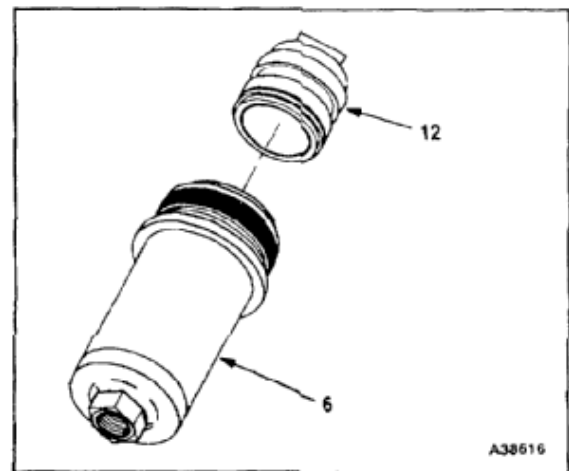

8. Remove T-ring (13) from separator (12).
9. Measure outside diameter of separator (12). Diameter shall not be less than **1.611 inches**.
10. Measure inside diameter of housing (6). Diameter shall not be more than **1.619 inches**.
11. Inspect all parts for wear and damage (cracks, nicks, burrs, etc.). Carefully inspect inside wall of housing for scoring. Replace parts as required.

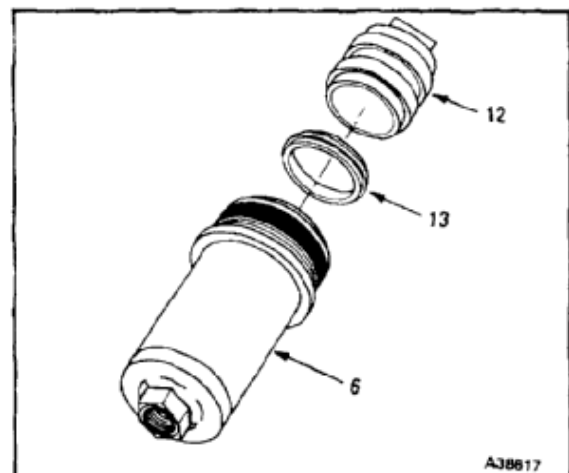

FOLLOW-ON MAINTENANCE:

None

END OF TASK

INITIAL SETUP

Applicable Configurations:

All

Tools:

Hydraulic Repairer's Tool Kit, NSN 5180-00-323-4891
 Strap Wrench, 15/16 to 5-9/16 Inches
 Crowfoot Wrench, 1 Inch
 Torque Wrench, 700 to 1600 Inch-Pounds
 Depth Gage, 0 to 0.125 Inch
 Source of Low Pressure Compressed Air
 Soft Jawed Vise

Materials:

Dry Cleaning Solvent (E162)
 Hydraulic Fluid (E199)
 Cloth (E120)
 Lockwire (E227)
 Adhesive (E43)
 Methyl-Ethyl-Ketone (E244)
 Gloves (E186)

WARNING

Dry cleaning solvent (E162) is flammable and toxic. It can irritate skin and cause burns. Use only in well-ventilated area, away from heat and open flame. In case of contact, immediately flush skin or eyes with water for at least **15 minutes**. Get medical attention for eyes.

1. Clean all parts (1 thru 6) with dry cleaning solvent (E162). Dry with low pressure compressed air. Use goggles for eyes. Use gloves (E186).

INSPECT

2. Cover parts (1 thru 6) with cloth (E120) to keep off dust and dirt until needed.

Parts:

Packings
 Retaining Rings

Personnel Required:

Aircraft Pneudraulics Repairer (2)
 Inspector

References:

TM 55-1520-240-23P

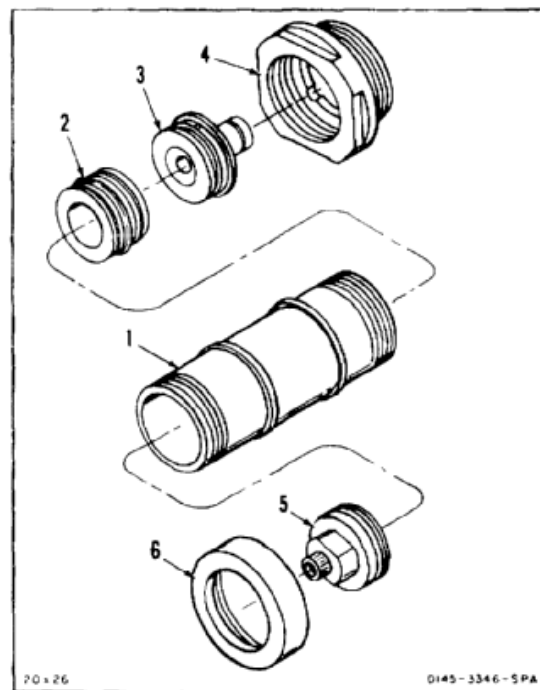

3. Apply light coat of hydraulic fluid (E199) to inside walls of shell (1). Use cloth (E120).

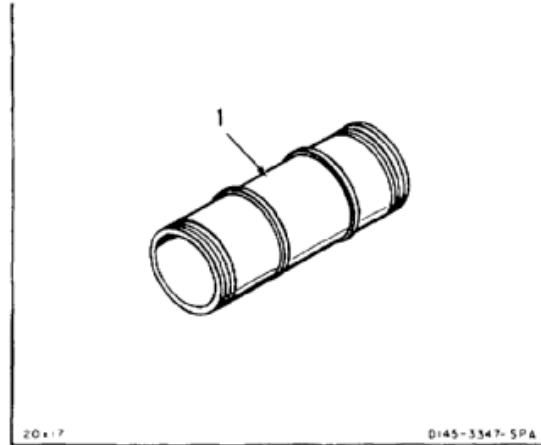

4. Install tee packing (7) on piston (2).
5. Install retaining rings (8), one on each side of tee packing (7). Make sure chamfer on retainers are against tee packing as shown. Position slots in rings **180°** apart.

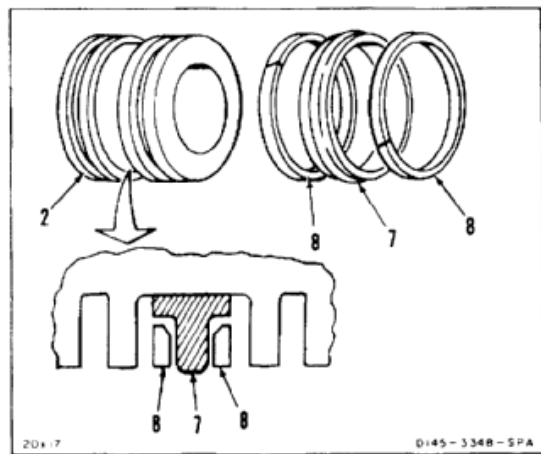

6. Coat Teflon rings (9) with light coat of hydraulic fluid (E199). Install two Teflon rings (9) on piston (2). Position slots in rings **180°** apart.

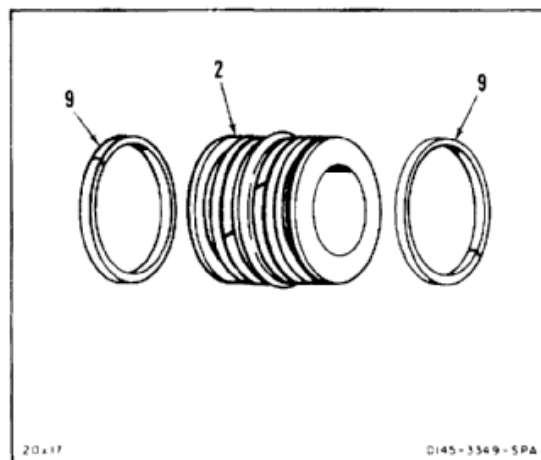

7. Install shell (1) in vise (10).
8. Install piston (2) in shell (1).

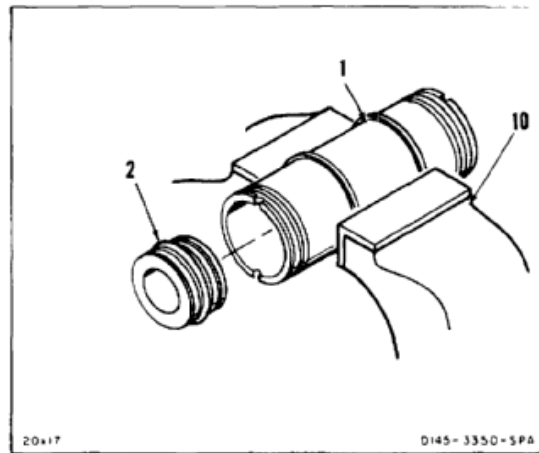

9. Install two pins (11) in end cap (5). Pins shall be from flush to **0.005 inch** below surface of end cap.
10. Install retaining ring (12) and packing (13) on end cap (5).

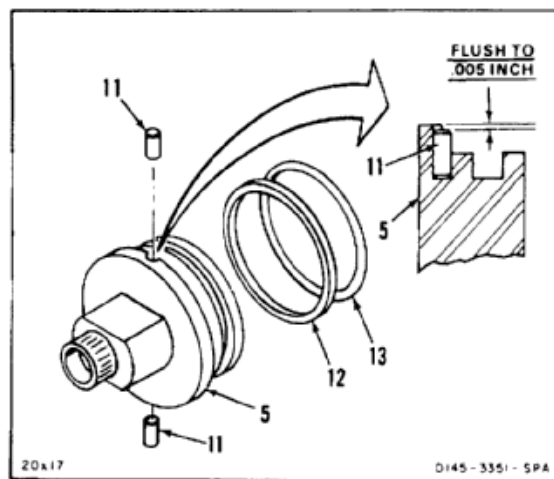

11. Install end cap (5) in shell (1). Pins (11) shall be seated in shell grooves (14).

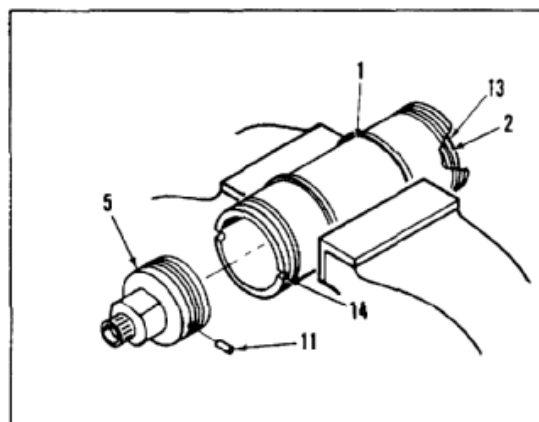

12. Install nut (6) on shell (1) over end cap (5). Use strap wrench.

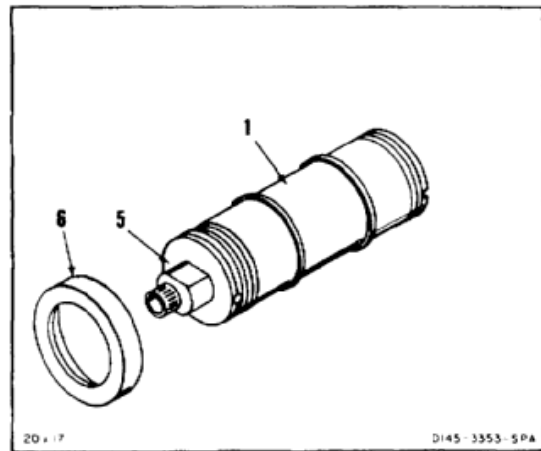

13. Install two pins (15) in end cap (3). Pins shall be from flush to **0.005 inch** below surface of end cap.
14. Install retaining ring (16) and packing (17) on end cap (3).

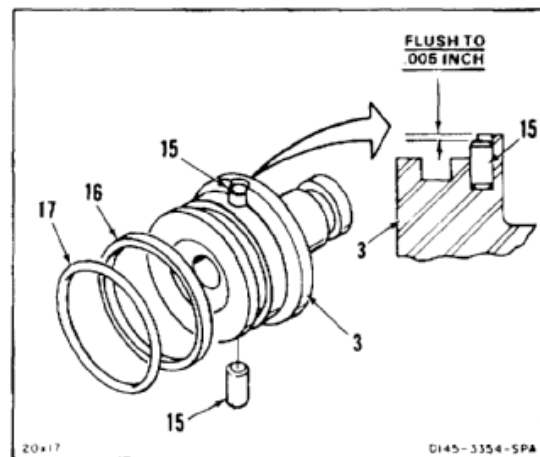

15. Install end cap (3) in shell (1) on opposite end of nut (6). Pins (15) shall be seated in shell grooves (18).
16. Remove shell (1) from vise (10).

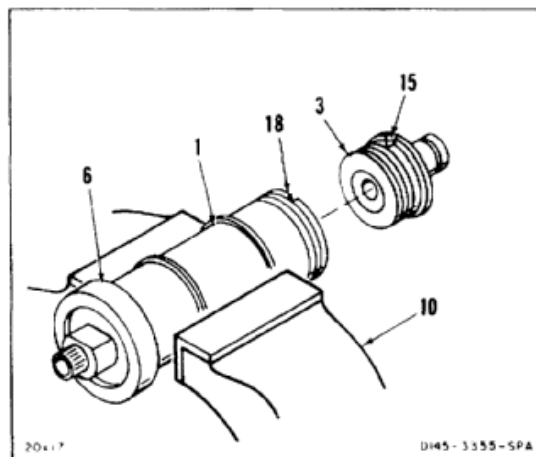

17. Install nut (4) on shell (1) hand tight.
18. Clamp nut (4) in vise (10).
19. Torque end cap (6) until hole (20) in end cap (3) aligns with notch (21) in nut (4). Use **1 inch** crowfoot and torque wrench on end cap (5). Do not exceed **1200 inch-pounds**.
20. Install pin (22) into hole (20).

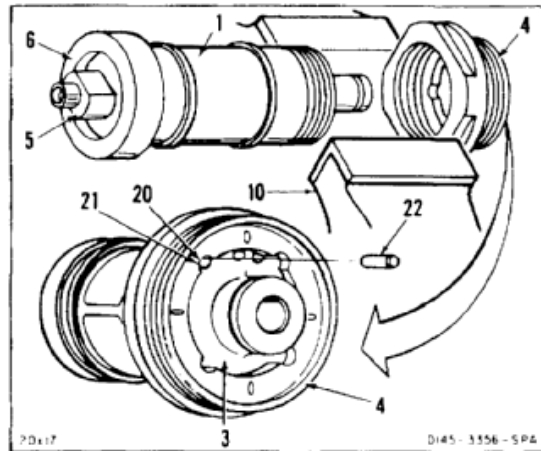

21. Lockwire cap (3) to nut (4). Use lockwire (E227).
22. Lockwire cap (5) to nut (6). Use lockwire (E227).
23. Remove nut (4) from vise (10).

INSPECT

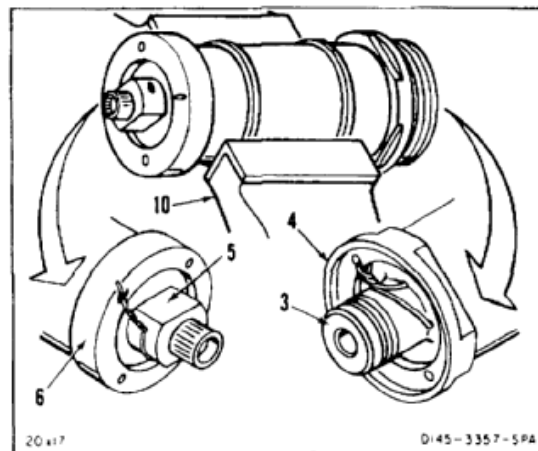

WARNING

Methyl-ethyl-ketone (E244) is flammable and toxic. It can irritate skin and cause burns. Use only in well-ventilated area, away from heat and open flame. In case of contact, immediately flush skin or eyes with water for at least **15 minutes**. Get medical attention for eyes.

WARNING

Adhesive (E43) can irritate skin and cause burns. Avoid contact with skin, eyes, and clothing. In case of contact, immediately flush skin or eyes with water for at least **15 minutes**. Get medical attention for eyes.

24. If shell (1) is being replaced or nameplate (23) was removed, install nameplate as follows:
- Clean shell (1), nameplate (23), and strap (24) with methyl-ethyl-ketone (E244). Use cloth (E120).
 - Apply adhesive (E43) to all contact surfaces between shell (1), nameplate (23), and strap (24).
 - Wrap nameplate (23) and strap (24) around shell (1). Interlock by running strap through nameplate and bending as shown.

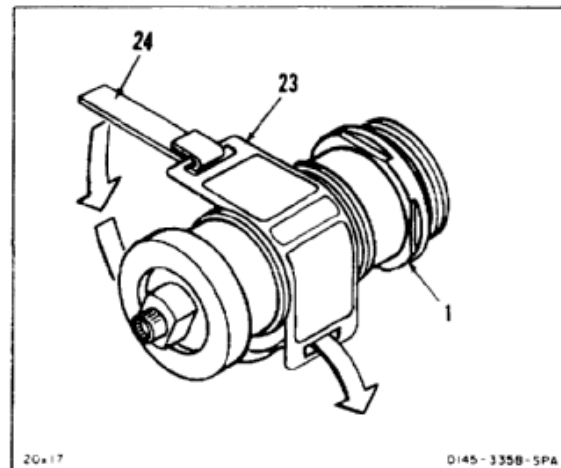
**FOLLOW-ON MAINTENANCE:**

Test accumulator (Task 7-50).

END OF TASK

INITIAL SETUP

Applicable Configurations:

All

Tools:

Hydraulic Repairer's Tool Kit, NSN 5180-00-323-4891
 Wrench, 3/4 Inch Open End
 Torque Wrench, 0 to 100 Foot-Pounds
 Source of Low Pressure Compressed Air
 Soft Jawed Vise
 Goggles

Materials:

Dry Cleaning Solvent (E162)
 Hydraulic Fluid (E199)
 Cloth (E120)
 Gloves (E186)

Parts:

Packings
 Retainer Rings

Personnel Required:

Aircraft Pneudraulics Repairer (2)
 Inspector

References:

TM 55-1520-240-23P

WARNING

Dry cleaning solvent (E162) is flammable and toxic. It can irritate skin and cause burns. Use only in well-ventilated area, away from heat and open flame. In case of contact, immediately flush skin or eyes with water for at least **15 minutes**. Get medical attention for eyes.

1. Clean all parts (1 thru 3) with dry cleaning solvent (E162). Dry with low pressure compressed air. Use goggles for eyes. Use gloves (E186).

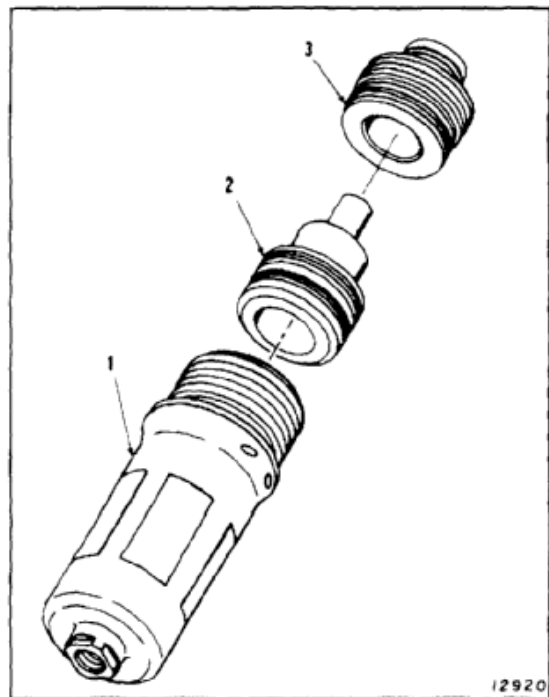

12920

- Lightly coat packings (4) and retainer rings (5) with hydraulic fluid (E199). Use cloth (E120).

CAUTION

Ensure retainer rings (5) for packing (4) are installed with radius of ring (5) in corner of packing (4).

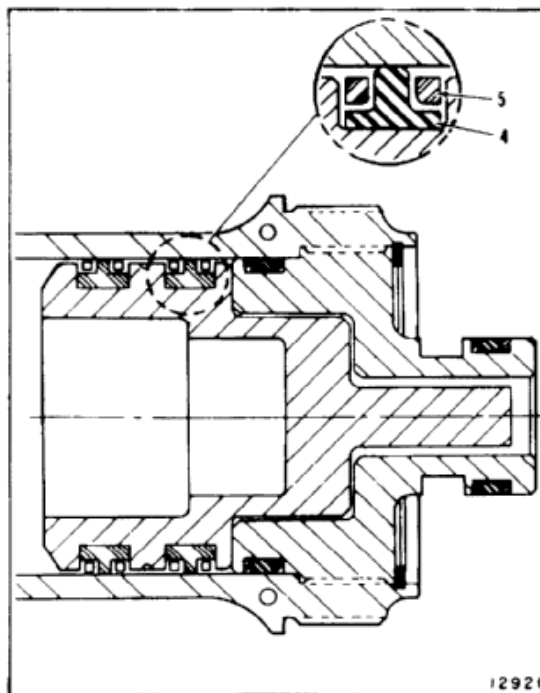

- Install packing (4) and retainer rings (5) in grooves of piston (2).

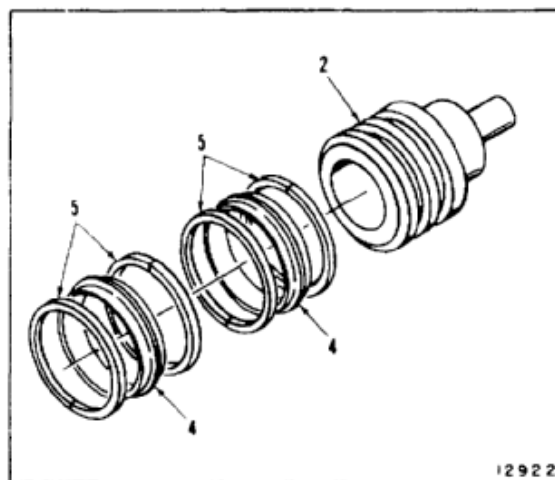

4. Lightly coat retainer rings (7) and packing (6) with hydraulic fluid (E199). Install packing (6) and retainer rings (7) in groove of retainer (3).

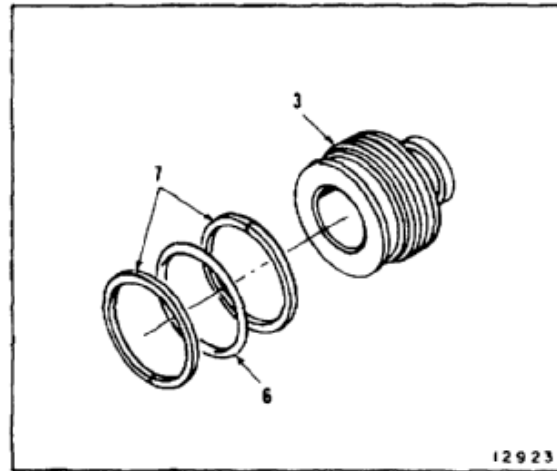

5. Apply light coat of hydraulic fluid (E199) to inside wall of housing (1) and OD of piston (2) in area of packing (4). Use cloth (E120).
6. Install large end of piston (2) into housing (1) for distance of approximately **two inches**.

NOTE

The **two inches** will allow enough space to insert retainer (3).

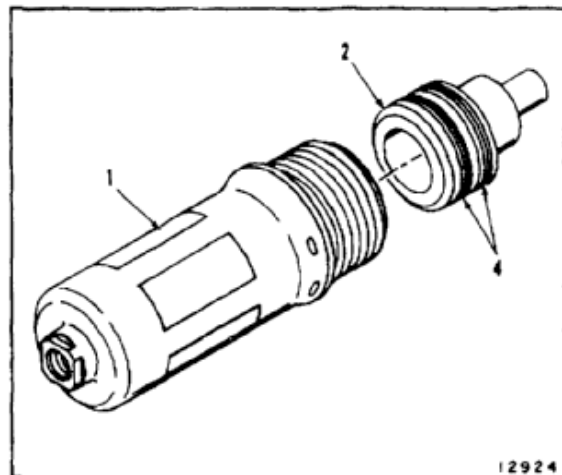

7-49.1 ASSEMBLE ACCUMULATOR (AD-A620-1D340)(AVIM) (Continued)

7-49.1

7. Place gas port end of housing (1) in vise (10).
8. Apply light coat of hydraulic fluid (E199) in retainer area of packing (6). Use cloth (E120).
9. Thread retainer (3) into housing (1) and torque to **30 to 40 foot-pounds**.

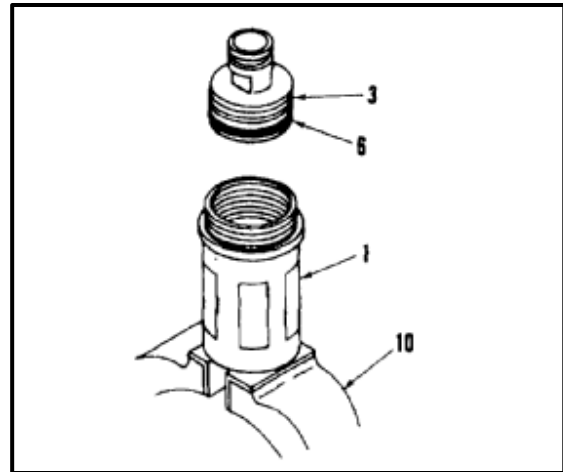

10. Install spiral retaining ring (11) into retaining ring groove of housing (1).
11. Apply light coat of hydraulic fluid (E199) to packing (12) and retainer rings (13).
12. Install packing (12) and retainer rings (13) on port end of retainer (3).
13. Remove accumulator (1) from vise (10).

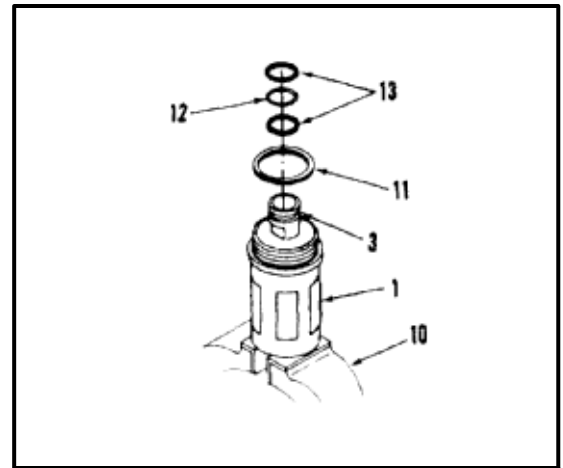
**FOLLOW-ON MAINTENANCE:**

Test accumulator (Task 7-50).

END OF TASK

INITIAL SETUP

Applicable Configurations:

All

Tools:

Hydraulic Repairer's Tool Kit, NSN 5180-00-323-4891
 Source of Low Pressure
 Compressed Air
 Soft Jawed Vise
 Goggles

Materials:

Dry Cleaning Solvent (E162)
 Hydraulic Fluid (E199)
 Cloth (E120)
 Gloves (E184.1)

Parts:

Packings
 Retainer Rings

Personnel Required:

Aircraft Pneudraulics Repairer (2)
 Inspector

References:

TM 55-1520-240-23P

General Safety Instructions:**WARNING**

Hydraulic fluid (E199) is toxic. It can irritate skin and cause burns. Avoid inhaling. Use only with adequate ventilation. Avoid contact with skin, eyes, or clothing. In case of contact, immediately flush skin or eyes with water for at least **15 minutes**. Get medical attention for eyes.

WARNING

Dry cleaning solvent (E162) is flammable and toxic. It can irritate skin and cause burns. Use only in well-ventilated area, away from heat and open flame. In case of contact, immediately flush skin or eyes with water for at least **15 minutes**. Get medical attention for eyes.

1. Clean all parts (1 thru 3) with dry cleaning solvent (E162). Dry with low pressure compressed air. Wear goggles for eyes. Wear gloves (E184.1).

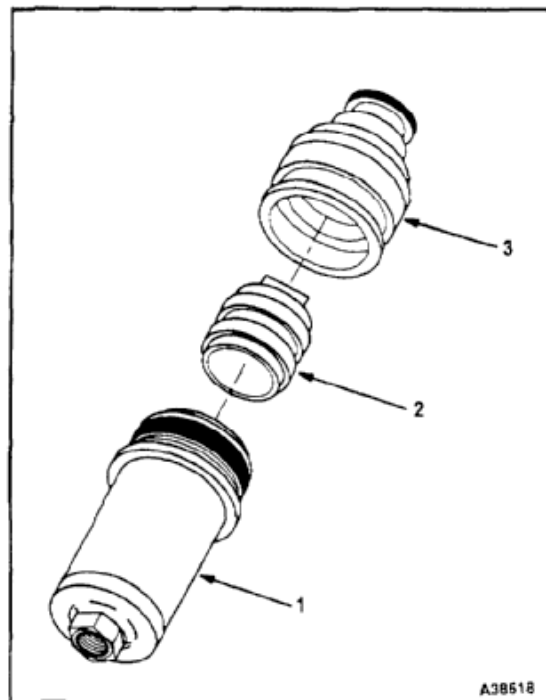

A38618

7-49.2 ASSEMBLE ACCUMULATOR (60910) (AVIM) (Continued)

7-49.2

2. Install T-ring (4) on separator (2). Apply a light coat of hydraulic fluid (E199) to inside wall of housing (1) and OD of separator (2). Use cloth (E120). Wear gloves (E184.1).
3. Install separator (2) in housing (1).

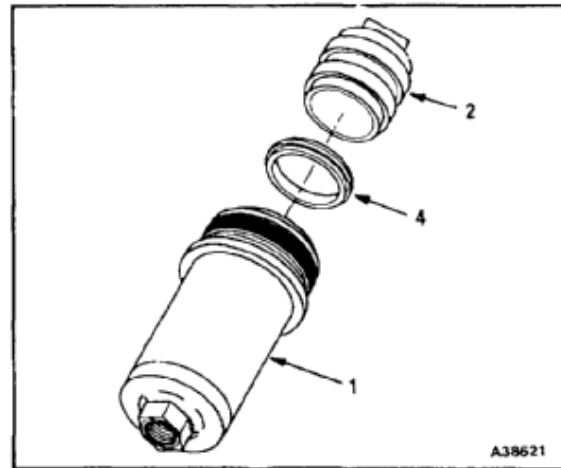

4. Lightly coat retainer rings (5 and 7), and packings (6 and 8) with hydraulic fluid (E199). Wear gloves (E184.1).
5. Install retainer rings (5 and 7), and packings (6 and 8), on end cap (3).

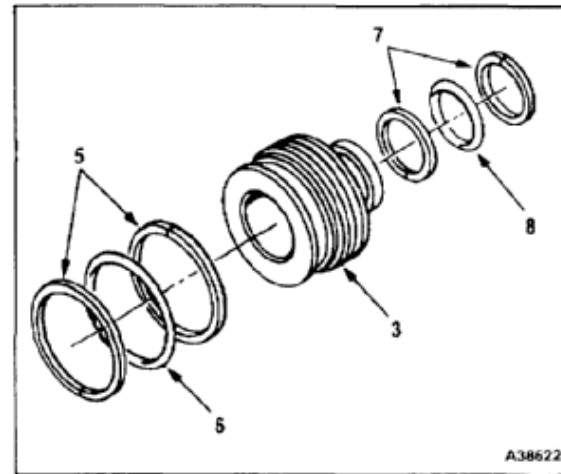

6. Place gas port end of housing (1) in vise (9).
7. Apply light coat of hydraulic fluid (E199) in end cap area of packings (6 and 8). Wear gloves (E184.1).
8. Install end cap (3) in housing (1). Secure end cap with retaining ring (10).
9. Install plate (11) on housing.
10. Install screws (12) into plate (10). Torque screws to **6 to 7 inch-pounds**.

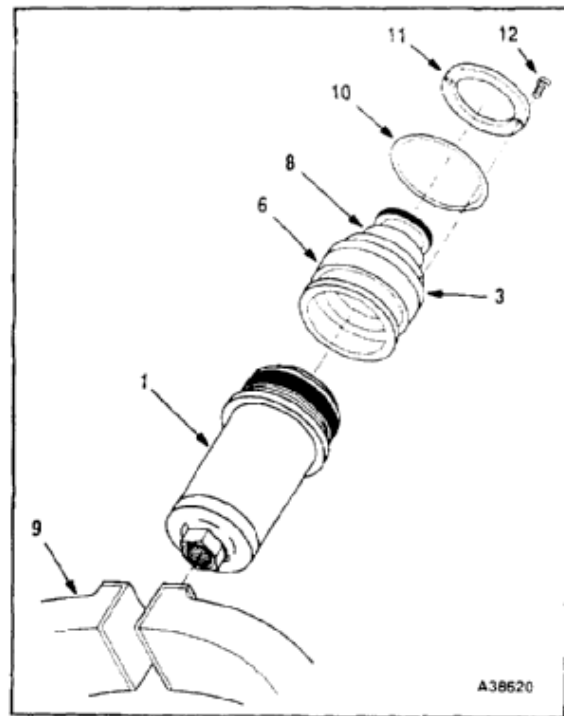
INSPECT**FOLLOW-ON MAINTENANCE:**

Test accumulator (Task 7-50).

END OF TASK

7-248

INITIAL SETUP

Applicable Configurations:

All

Tools:

- Hydraulic Repairer's Tool Kit, NSN 5180-00-323-4891
- Hydraulic Pressure Gage, 6000 psi
- Hydraulic Test Stand
- Test Block (145G0055-1)
- Wood Dowel, 3/8 Inch X 6 Inches
- Nitrogen Supply With Regulator
- Hydraulic Pressure Gage, 500 psi
- Shutoff Valve (4)
- Air Pressure Gage, 10 psi
- Restrictor Valve
- Graduate, 5 cc
- Reservoir (APP E-11)
- Tube, 1/4 Inch, 0 to 5000 psi
- Nipple, 1/4 Inch
- Tee, 1/4 Inch (5)
- Stop Watch

Materials:

- Cloth (E120)
- Hydraulic Fluid (E198)
- Hydraulic Fluid (E199)
- Gloves (E184.1)

Personnel Required:

- Aircraft Pneudraulics Repairer
- Inspector

References:

- Appendix E
- TM 55-1520-240-23P

Equipment Condition:

- Off Helicopter Task
- Test Setup
- Accumulator Installed in Crash Proof Box

General Safety Instructions:

WARNING

Hydraulic fluid (E199) is toxic. It can irritate skin and cause burns. Avoid inhaling. Use only with adequate ventilation. Avoid contact with skin, eyes, or clothing. In case of contact, immediately flush skin or eyes with water for at least **15 minutes**. Get medical attention for eyes.

WARNING

Hydraulic fluid (E199) ejected under pressure can cause injury to personnel. Hydraulic fluid sprayed into the air is a fire hazard.

WARNING

Use suitable crash proof box to shield personnel and equipment in case of failure during test.

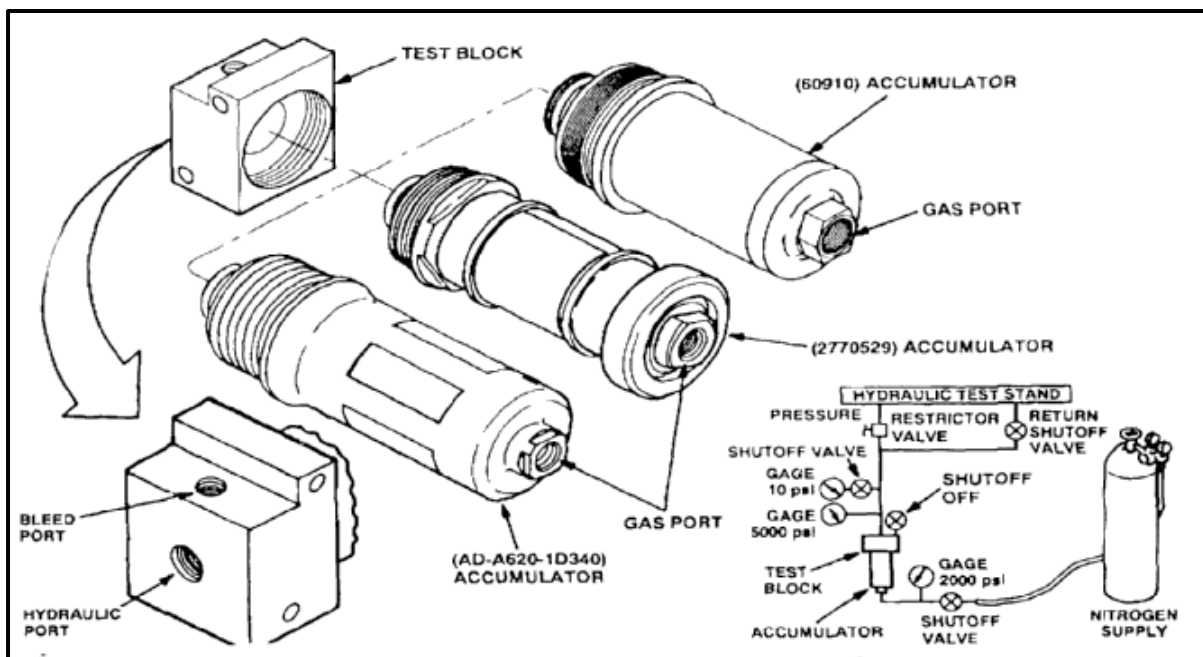

NOTE

Manifold remains on for all tests.

1. Install accumulator (1) in test block (2).
2. Position piston (3) midway into accumulator (1). Use wood dowel (4).

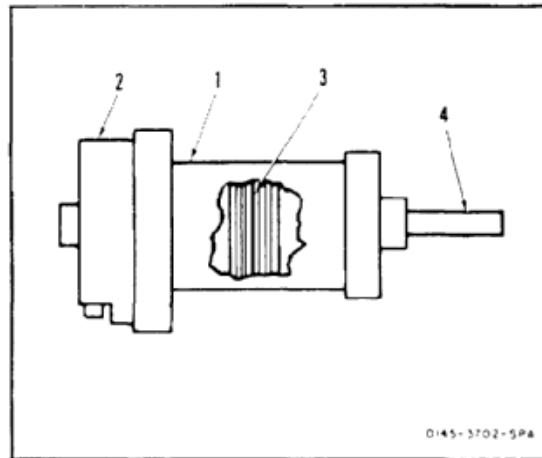

- 2.1. Position accumulator (1) with port (4.1) facing up. Fill accumulator with hydraulic fluid (E199) through port (4.1). Wear gloves (E184.1).
- 2.2. Install plug (4.2) and packing (4.3) in port (4.1).

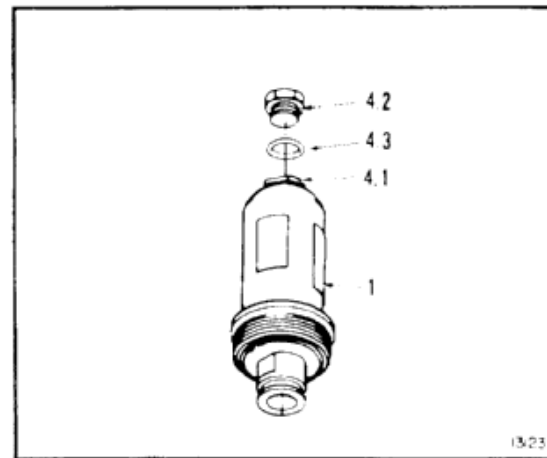

- 2.3. Position accumulator (1) with port (4.4) up. Fill accumulator (1) through port (4.4) with hydraulic fluid (E199). Wear gloves (E184.1).
- 2.4. Install two retainers (4.5) and packing (4.6) in groove of retainer (4.7).
- 2.5. Install accumulator (1) in test block (2).

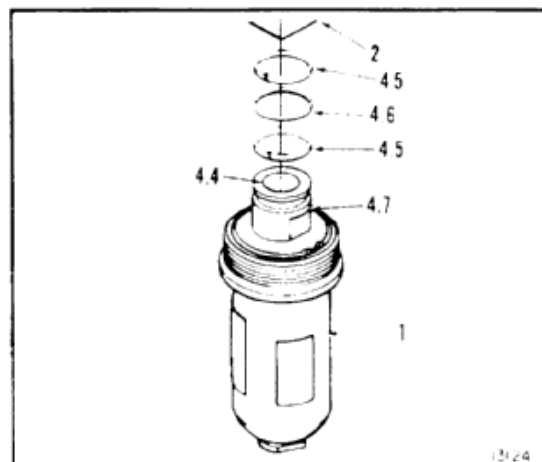

INTEGRITY PRESSURE TEST

3. Connect fluid port (5) of test block (2) to test setup (6) as shown.
4. Connect valve (7) to bleed port (8) of test block (2).
5. Close valves (7, 9, and 10).
6. Apply **4500 psi** pressure to port (5). Adjust valve (10) for **4500 psi** on gage (12). Maintain pressure for **2 minutes**.
7. Check accumulator (1) for leakage. There shall be no leakage.
8. Release pressure to **0 psi** on gage (12). Close valve (11). Open valve (10).
9. Close valve (10).
10. Repeat steps 6 thru 9. Then perform step 11.

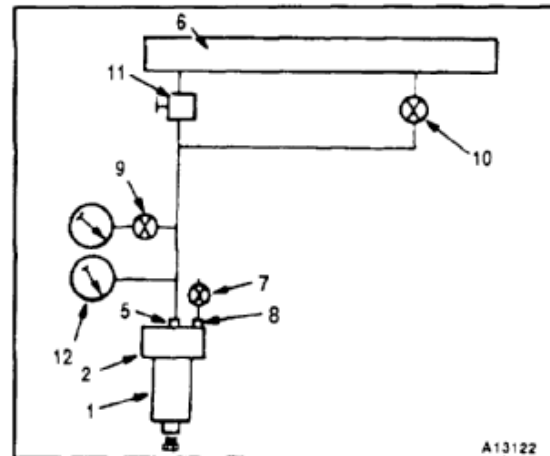

FLUID LEAKAGE TEST

11. Open valve (9). Apply **2 psi** pressure to port (5). Adjust valve (11) for **2 psi** on gage (13). Maintain pressure for **3 minutes**.
12. Check for leakage at port (14). Leakage at port (14) shall be insufficient to form a drop.
13. Release pressure to **0 psi** on gage (13). Close valve (11). Open valve (10).
14. Close valves (9 and 10).
15. Apply **3000 psi** pressure to port (5). Adjust valve (11) for **3000 psi** on gage (12). Maintain pressure for **30 minutes**.
16. Check for leaks at port (14). Leakage at port (14) shall be insufficient to form a drop.
17. Release pressure to **0 psi** on gage (12). Close valve (11). Open valve (10).
18. Disconnect test setup (6) from port (5).

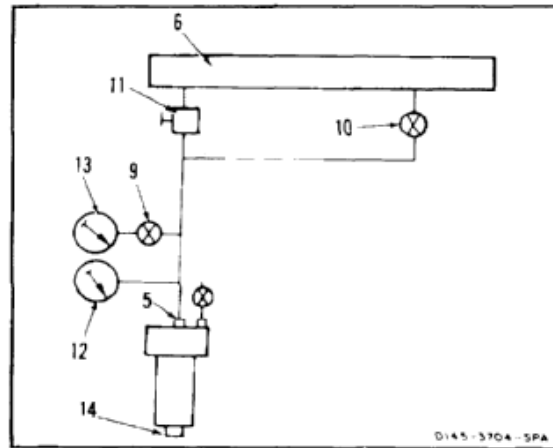

GAS LEAKAGE TEST

19. Insert wood dowel (4) through port (14) to contact piston of accumulator (1). Push dowel until piston bottoms. Remove dowel.
20. Connect reservoir (15) to port (5).
21. Fill reservoir (15) with hydraulic fluid (E199) until tube (16) is covered.
22. Bleed air from block (2). Open valve (7). Wear gloves (E184.1). Use cloths (E120) for spilled fluid.
23. Close valve (7).

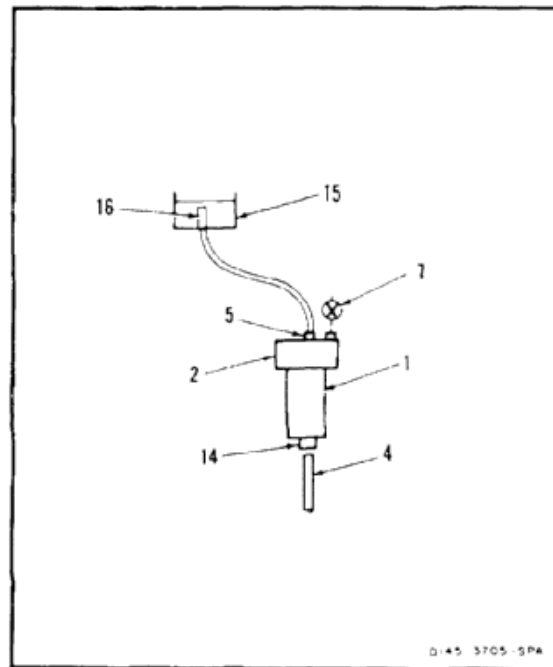

24. Position accumulator (1) on its side.
25. Connect nitrogen supply (17) along with valve (18) and gage (19) to port (14).
26. Apply **200 psi** pressure to port (14). Open valve (18) for **200 psi** on gage (19). Close valve (18).
27. Fill graduate (20) with hydraulic fluid (E199). Place graduate over tube (16) in reservoir (15). Fluid level in graduate must be above fluid level in reservoir. Use **5 cc** graduate. Wear gloves (E184.1).
28. Record fluid level in graduate (20). Check fluid level after **3 minutes**. Fluid level shall not change by more than **.25 cc**.
29. Open valve (18). Adjust for **2000 psi** on gage (19). Close valve (18).
30. Repeat step 28, then perform step 31.
31. Release pressure to **0 psi** on gage (19). Open regulator (21).
32. Remove graduate (20) from reservoir (15).
33. Disconnect reservoir (15) from port (5). Use container for spilled fluid.
34. Disconnect valve (7) from port (8).

WARNING

Deplete air pressure before disconnecting tubes or hoses. Otherwise, injury to personnel can occur.

35. Disconnect supply (17) from port (14).
36. Remove accumulator (1) from block (2).

INSPECT**FOLLOW-ON MAINTENANCE:**

None

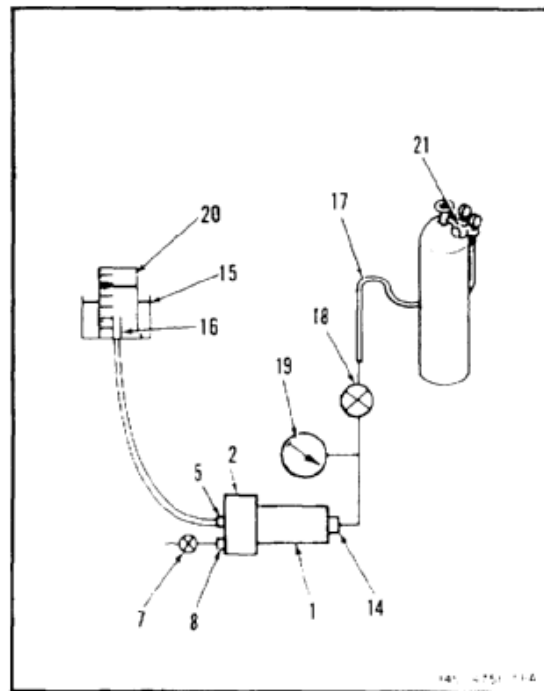

END OF TASK

INITIAL SETUP

Applicable Configurations:

All

Tools:

Aircraft Mechanic's Tool Kit, NSN 5180-00-323-4692
Open End Wrench, 2-1/2 Inch

Materials:

Lockwire (E231)

Parts:

Preformed Packings
Retainers

Personnel Required:

Medium Helicopter Repairer
Inspector

References:

TM 55-1520-240-23P

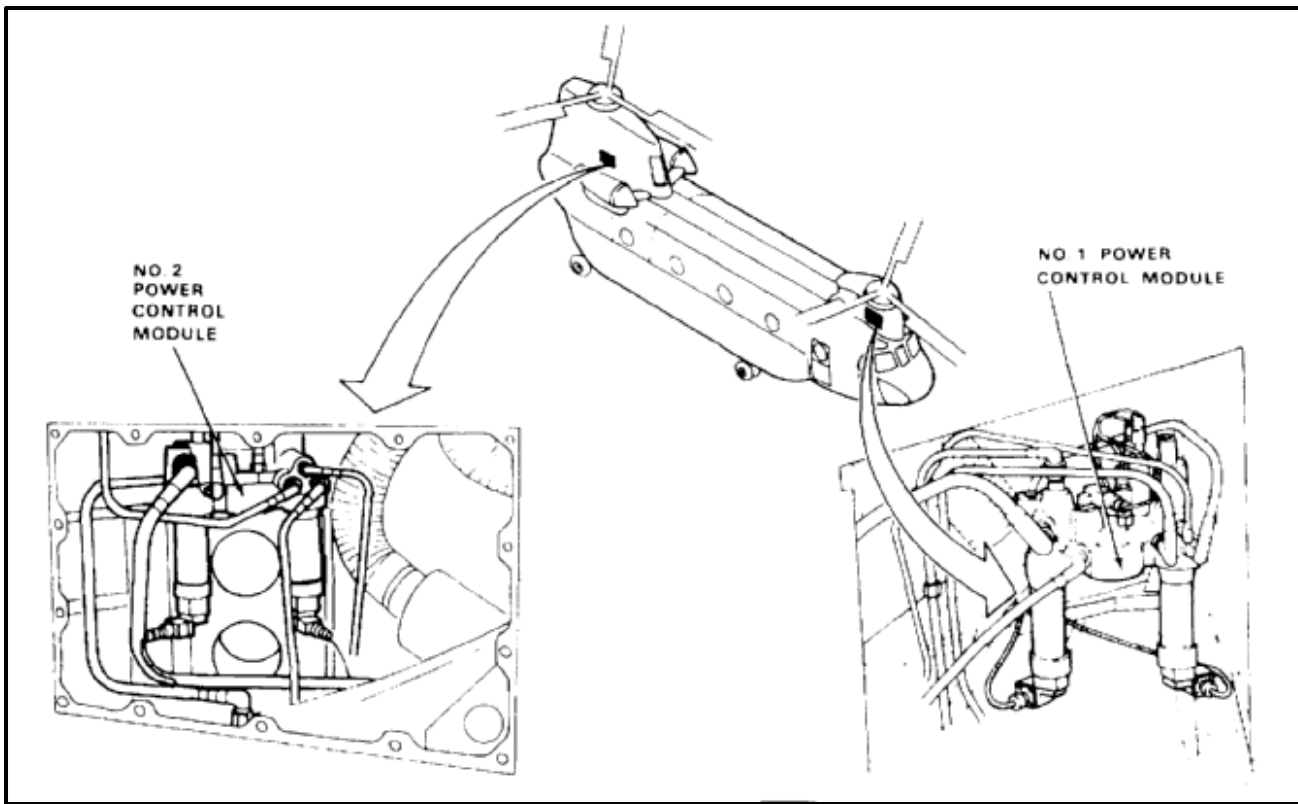

NOTE

There are two accumulators, one in No. 1 and one in No. 2 module. Procedure is same to install any accumulator. No. 1 module is shown here.

1. Install fitting (1) and packing (2) in accumulator (3).

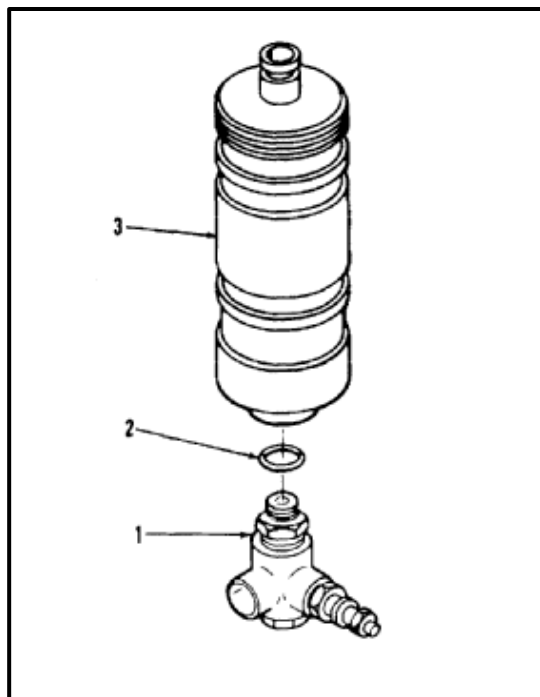

2. Install accumulator (3), two retainers (4), and packing (5) in module (6). Tighten accumulator. Use open end wrench.

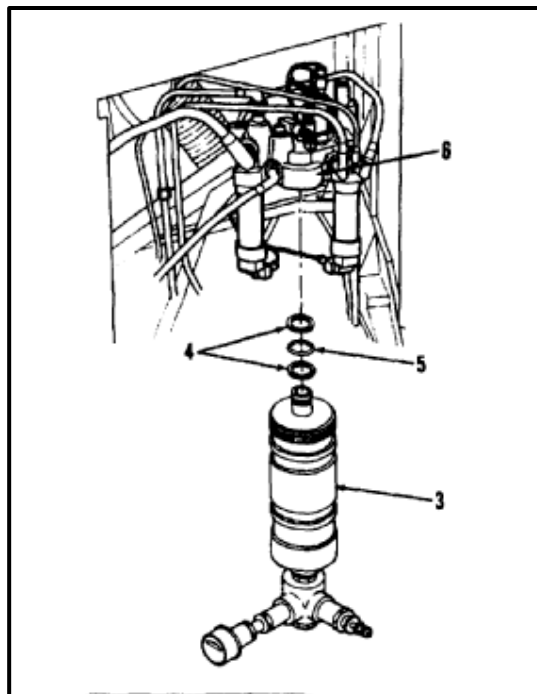

3. Lockwire valve (1) to accumulator (3). Lockwire accumulator to module (6). Use lockwire (E231).
4. Install gage (7), 45° aft of outboard, and packing (8) in fitting (9). Tighten nut (10).

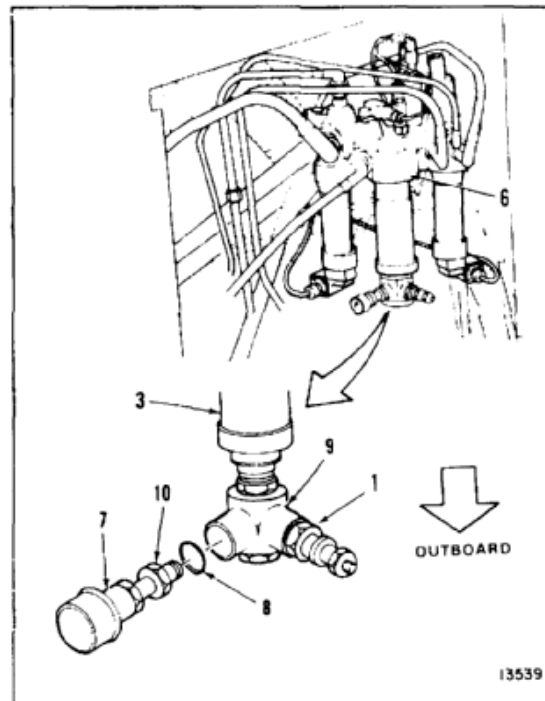
INSPECT**FOLLOW-ON MAINTENANCE:**

- Service No. 1 or No. 2 flight control accumulator (Task 1-63).
- Perform operational check (TM 55-1520-240-T).
- Close right forward work platform or install right pylon access door (Task 2-2).

END OF TASK

7-52 REMOVE NO. 1 OR NO. 2 POWER CONTROL MODULE FILTER CHECK VALVE

7-52

INITIAL SETUP

Applicable Configurations:

All

Tools:

Aircraft Mechanic's Tool Kit, NSN 5180-00-323-4692

Materials:

Cloths (E135)
Gloves (E188)

Personnel Required:

Medium Helicopter Repairer

Equipment Condition:

Battery Disconnected (Task 1-39)
Electrical Power Off
Hydraulic Power Off
Right Forward Work Platform or Right Pylon Access
Door Open (Task 2-2)

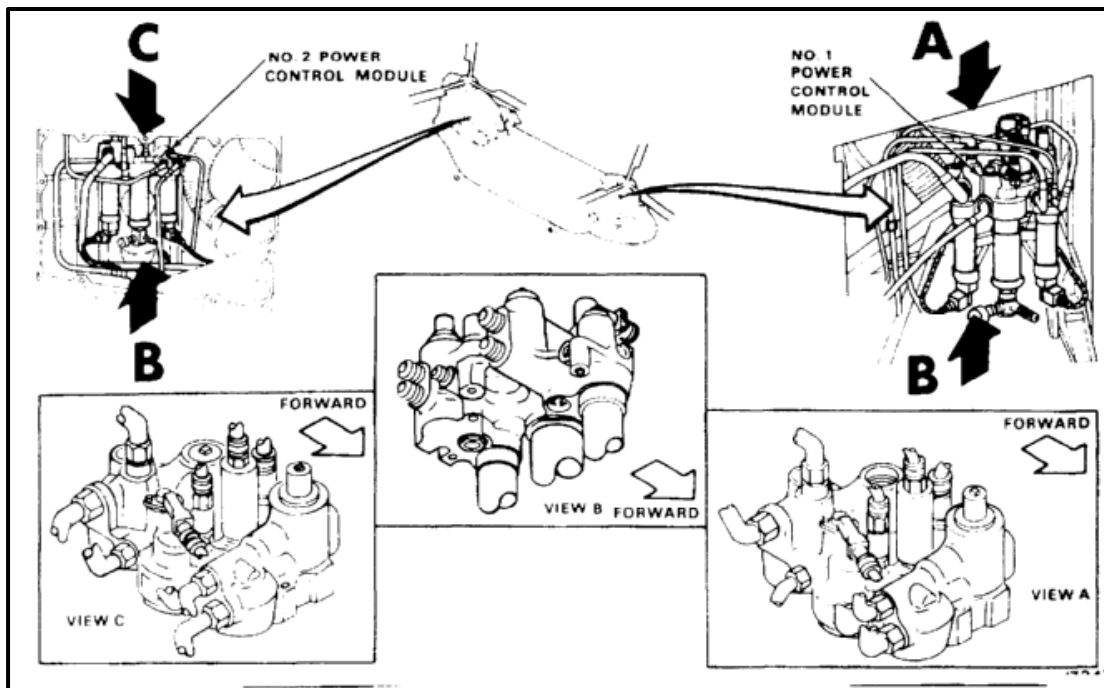

NOTE

There are four filter check valves, two in No. 1 and two in No. 2 module. Procedure is same to remove any filter check valve. No. 1 module is shown here.

1. Remove lockwire from valve (1). Remove valve, four retainers (2), and two packings (3) from module (4). Use cloths (E135) for spilled fluid. Use gloves (E186).

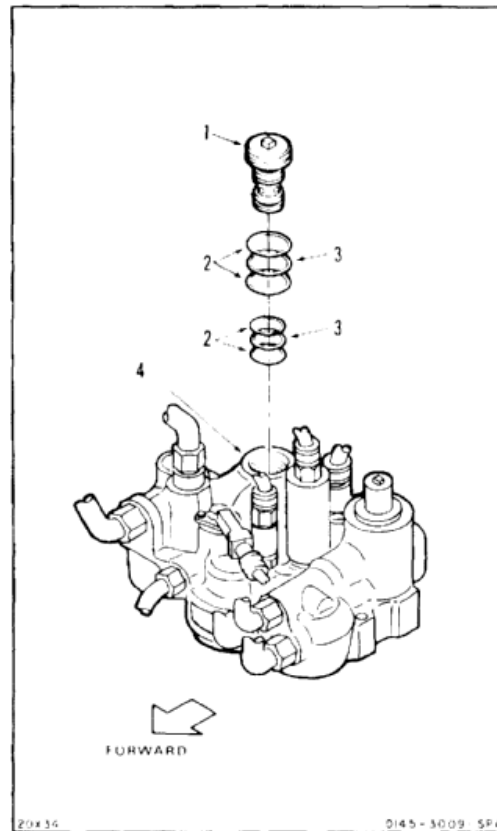
**FOLLOW-ON MAINTENANCE:**

None

END OF TASK

7-258

INITIAL SETUP

Applicable Configurations:

All

Tools:

Aircraft Mechanic's Tool Kit, NSN 5180-00-323-4692
 Pipe Plug Socket, 3/8 Inch, 3/8 Inch Drive

Materials:

Lockwire (E231)

Parts:

Preformed Packings
 Retainers

Personnel Required:

Medium Helicopter Repairer
 Inspector

References:

TM 55-1520-240-23P

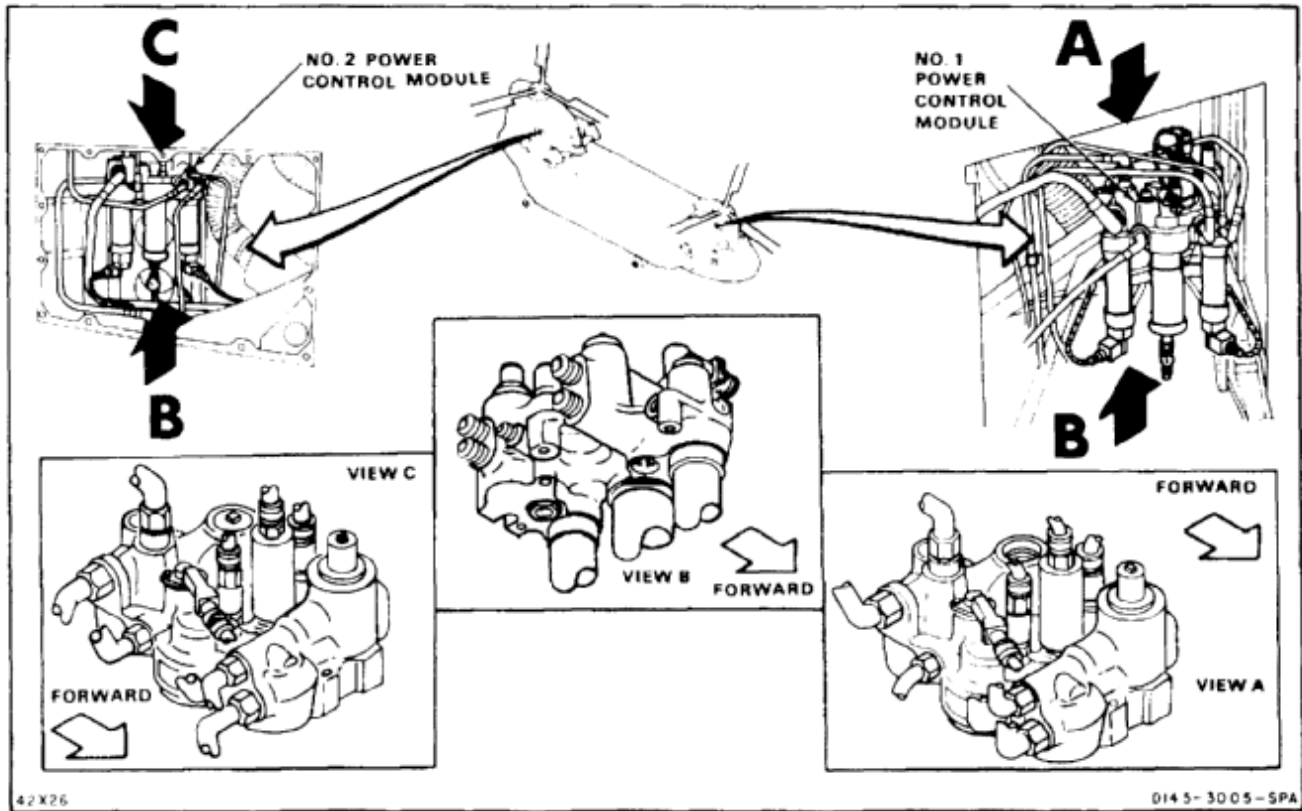

7-53 INSTALL NO. 1 OR NO. 2 POWER CONTROL MODULE FILTER CHECK VALVE (Continued)**NOTE**

There are four filter check valves, two in No. 1 and two in No. 2 module. Procedure is same to install any filter check valve. No. 1 module is shown here.

1. Install two retainers (1) and packing (2) on valve (3).
2. Install two retainers (4) and packing (5) on valve (3).
3. Install valve (3) in module (6).
4. Lockwire valve (1). Use lockwire (E231).

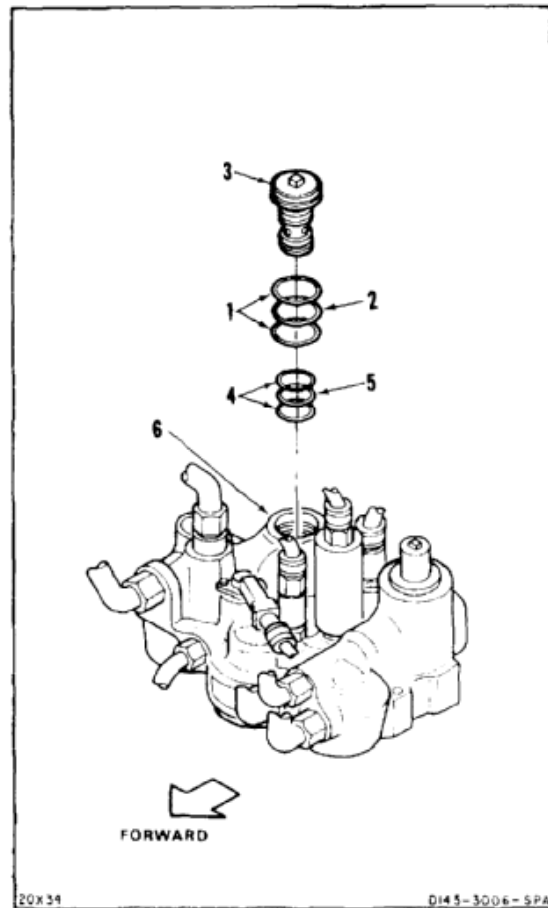
**INSPECT****FOLLOW-ON MAINTENANCE:**

Service flight control system (Task 1-60, 1-61, 1-62, or 1-63).

Perform operational check (TM 55-1520-240-T).

Close right forward work platform or right pylon access door (Task 2-2).

END OF TASK

7-260

INITIAL SETUP

General Safety Instructions:**Applicable Configurations:**

All

Tools:

Aircraft Mechanic's Tool Kit, NSN 5180-00-323-4692

Materials:Cloths (E135)
Gloves (E186)**Personnel Required:**

Medium Helicopter Repairer

Equipment Condition:Battery Disconnected (Task 1-39)
Electrical Power Off
Hydraulic Power Off
Utility Hydraulic System Depressurized (Task 7-135.1)
Forward Right Work Platform or Right Pylon Access
Door Open (Task 2-2)**WARNING**

Hydraulic fluid (E199) is toxic. It can irritate skin and cause burns. Avoid inhaling. Use only with adequate ventilation. Avoid contact with skin, eyes, or clothing. In case of contact, immediately flush skin or eyes with water for at least **15 minutes**. Get medical attention for eyes.

WARNING

Hydraulic fluid ejected under pressure can cause injury to personnel. Hydraulic fluid sprayed into the air is a fire hazard.

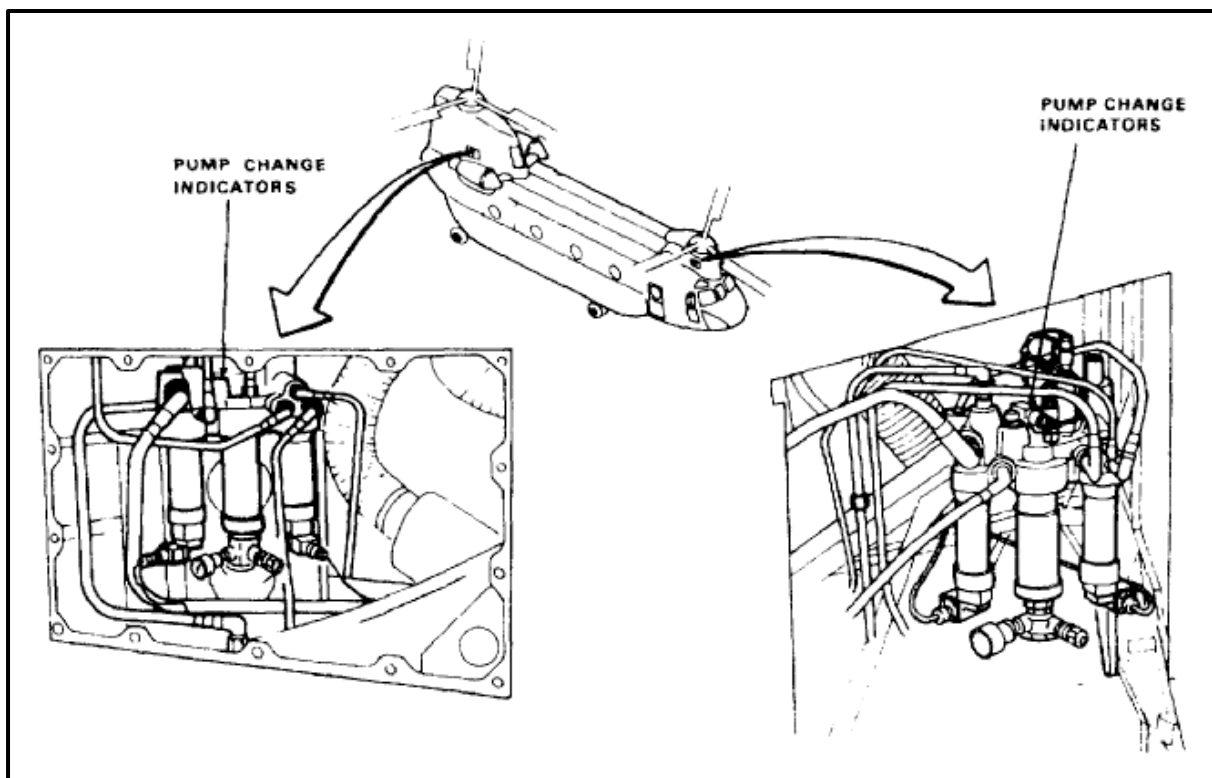

7-54 REMOVE NO. 1 OR NO. 2 POWER CONTROL MODULE PUMP CHANGE INDICATOR (Continued)

7-54

NOTE

There are two pump change indicators, one in No. 1 and one in No. 2 module. Procedure is same to remove any pump change indicator. No. 1 module is shown here.

1. Disconnect connector (1) from indicator (2).
2. Remove lockwire from three screws (3). Remove screws from indicator (2).
3. Remove indicator (2), retainer (4), and two packings (5) from module (6). Use cloths (E135) for spilled fluid. Use gloves (E186).

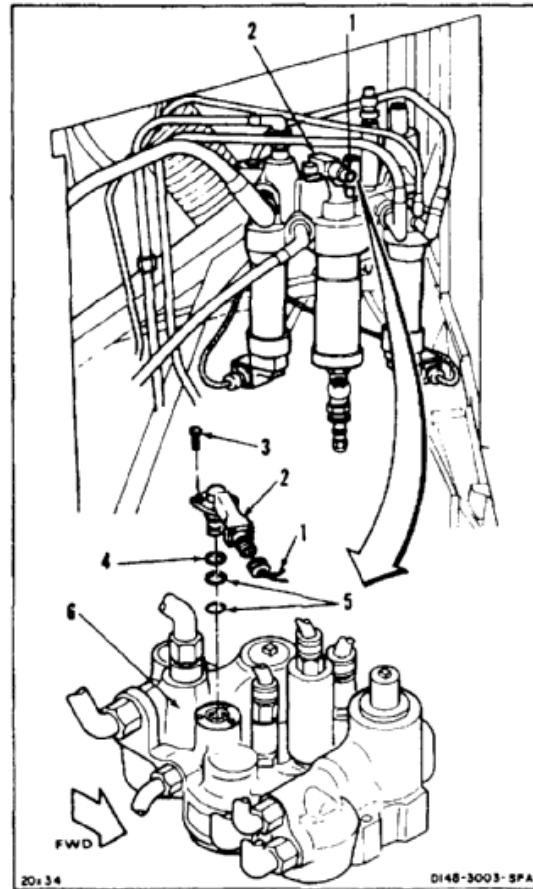
**FOLLOW-ON MAINTENANCE:**

None

END OF TASK

7-262

7-54.1 REMOVE NO. 1 OR NO. 2 POWER CONTROL MODULE MISCELLANEOUS CHECK VALVES

7-54.1

INITIAL SETUP

Applicable Configurations:

All

Tools:

- Hydraulic Repairer's Tool Kit, NSN 5180-60-323-4891
- Technical Inspection Tool Kit, NSN 5180-00-323-5114
- Combination Wrench and Drive Tool (Refer to Table)
- Lockring Puller (Refer to Table)
- Felt Tip Pen, Alcohol Soluble D10058

Materials:

- Dry Cleaning Solvent (E162)
- Gloves (E186)
- Cloth (E120)

Personnel Required:

- Aircraft Pneudraulics Repairer
- Aircraft Structural Repairer
- Inspector

References:

- Task 1-64
- Task 7-3

Equipment Condition:

- Battery Disconnected (Task 1-39)
- Electrical Power Off
- Hydraulic Power Off
- Right Forward Work Platform or Right Pylon Access Door Open (Task 2-2)

General Safety Intructions:

WARNING

Hydraulic fluid (E199) is toxic. It can irritate skin and cause burns. Avoid inhaling. Use only with adequate ventilation. Avoid contact with skin, eyes, or clothing. In case of contact, immediately flush skin or eyes with water for at least **15 minutes**. Get medical attention for eyes.

WARNING

Deplete hydraulic pressure in system before disconnecting any fitting. Hydraulic fluid ejected under pressure can cause injury to personnel. Hydraulic fluid sprayed into the air is a fire hazard.

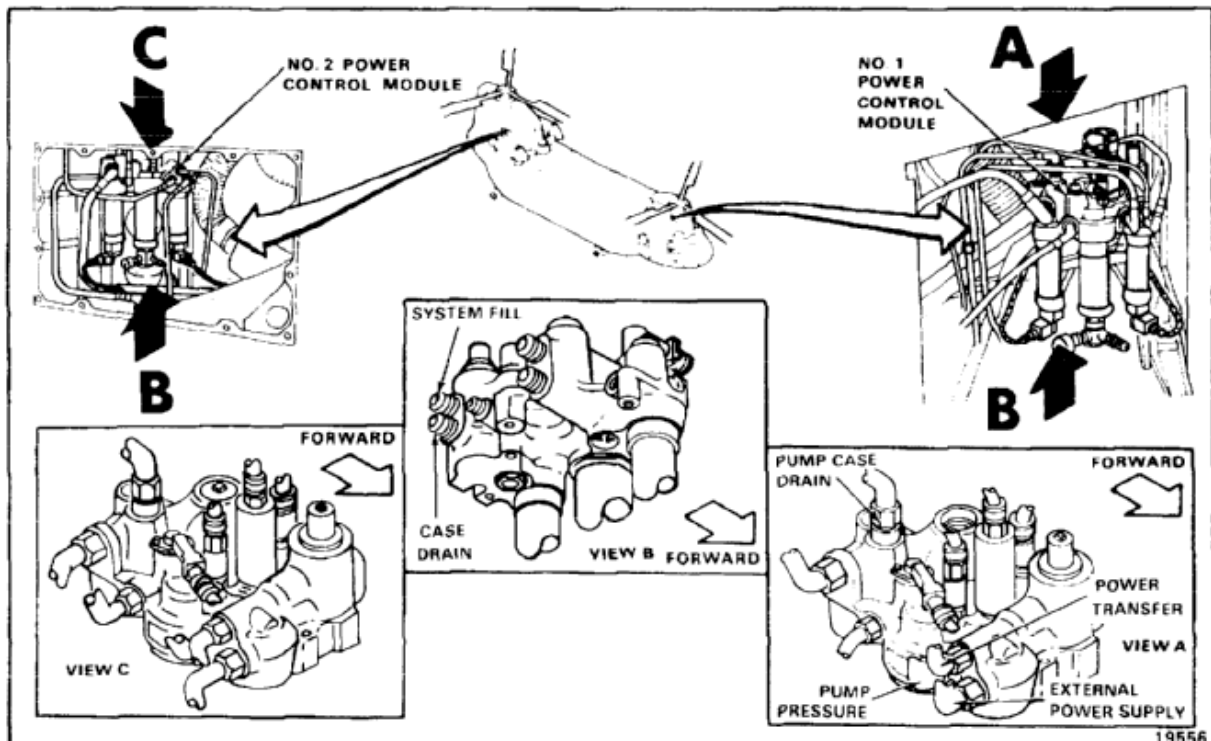

NOTE

The pump case drain check valve removal is shown. Procedure for removal of the system fill, power transfer, pump pressure, case drains, and external power supply check valves is the same.

Deplete pressure in system by cycling cockpit control stick (Task 1-64).

1. Disconnect and remove appropriate pipe or hose (refer to Task 7-3).
2. Clean area surrounding check valve. Use dry cleaning solvent (E162).
3. If reinstalling same check valve, mark locking (1) position. Use marking pen.
4. If sealant has been used to cover locking (1), carefully remove sealant.
5. Select proper locking removal tool from table.

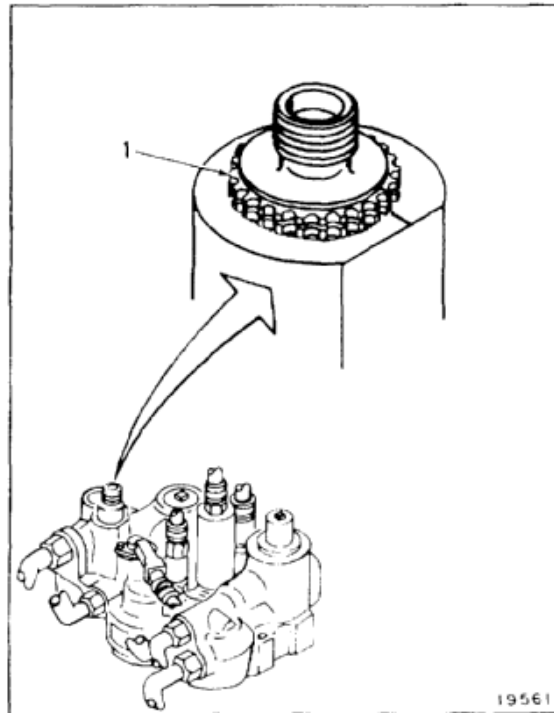

Check Valve	Combination Wrench and Drive Tool	Lockring Removal Tool
System Fill	RF9806DW	RF9806LPD
Case Drain	RF9808DW	RF9808LPD
Pump Case Drain	RF9816DW	RF9808LPD
Power Transfer	RF9810DW	RF9808LPD
Pump Pressure	RF9806DW	RF9806LPD
External Power Supply	RF9808DW	RF9808LPD

7-54.1 REMOVE NO. 1 OR NO. 2 POWER CONTROL MODULE MISCELLANEOUS CHECK VALVES (Continued)

7-54.1

6. Spread puller halves (2), by retracting sleeve (3) until pin (4) bottoms in groove (5).
7. Holding puller halves (2) apart, place tool over check valve (6). Release puller halves and locate tool over groove of lockring (1). Slide sleeve (3) over puller halves to close tool on locking groove. Check for proper engagement with locking groove.

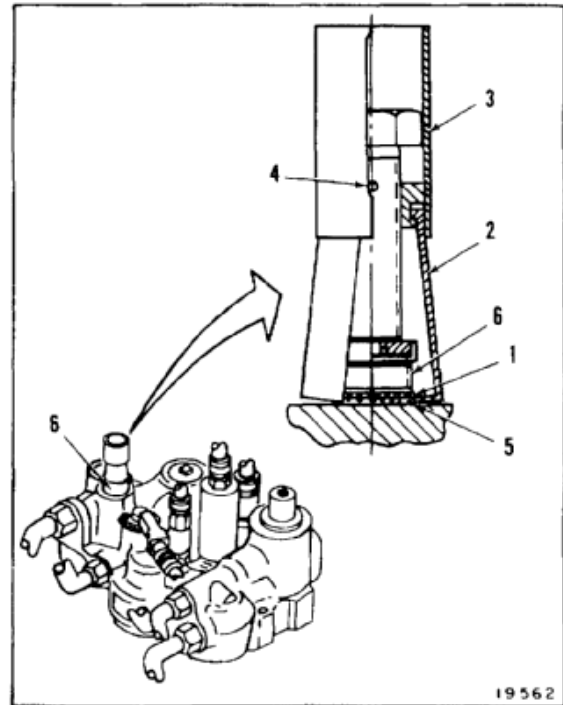

NOTE

Be sure to pull out lockring (1) straight, and only enough to clear lockring serrations.

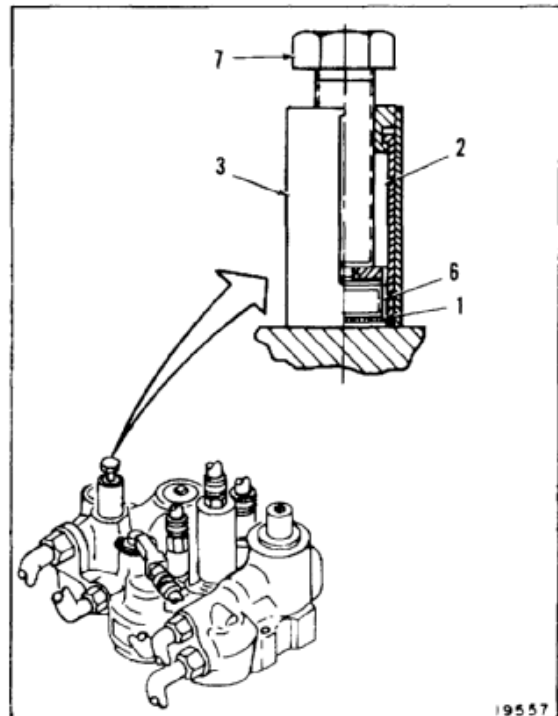
8. Turn bolt (7) clockwise while holding sleeve (3). This will jack the lockring (1) out of port (8). Stop turning bolt (7) when the external serrations of lockring (1) clear the port.
9. Loosen bolt (7), lift sleeve (3), and free puller halves (2). Remove tool from check valve (6).

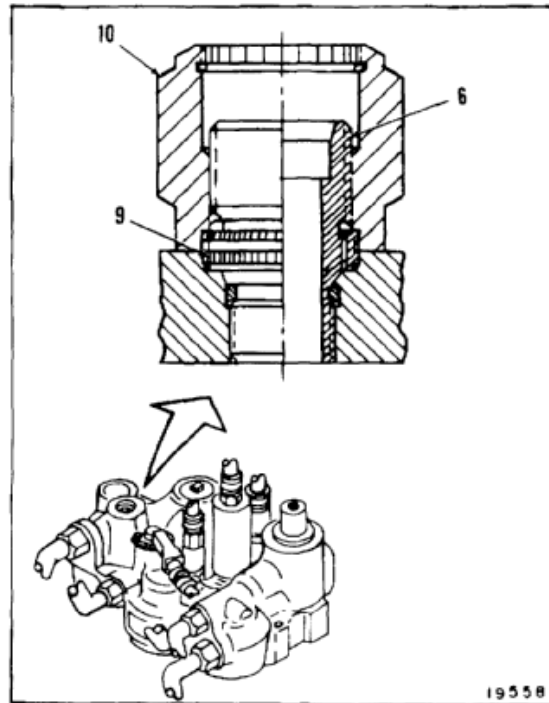

10. Select proper combination wrench and drive tool (10) from table. Engage wrench serrations with those of check valve serrations (9).
11. Turn wrench (10) counterclockwise to remove check valve (6). Remove check valve.
12. Check for damage. Remove packing. Clean off remaining sealant. Clean check valve. Check threads.

**FOLLOW-ON MAINTENANCE:**

None

END OF TASK

7-266

7-54.2 INSTALL NO. 1 OR NO. 2 POWER CONTROL MODULE MISCELLANEOUS CHECK VALVES 7-54.2

INITIAL SETUP

Applicable Configurations:

All

Tools:

- Hydraulic Repairer's Tool Kit, NSN 5180-00-323-4891
- Technical Inspection Tool Kit, NSN 5180-00-323-5114
- Packing Installation Tool (Refer to Table)
- Combination Wrench and Drive Tool (Refer to Table)
- Lockring Puller (Refer to Table)
- Torque Wrench, 3/8 Drive, 0 to 600 Inch-Pounds

Materials:

- Dry Cleaning Solvent (E162)
- Hydraulic Fluid (E199)
- Gloves (E186)
- Zinc Chromate Primer (E291)
- Acid Brush
- Cloth (E120)

References:

Task 7-4

Personnel Required:

- Aircraft Pneudraulics Repairer
- Aircraft Structural Repairer
- Inspector

Equipment Condition:

- Battery Disconnected (Task 1-39)
- Electrical Power Off
- Hydraulic Power Off
- Right Forward Work Platform or Right Pylon Access Door Open (Task 2-2)

General Safety Instructions:

WARNING

Hydraulic fluid (E199) is toxic. It can irritate skin and cause burns. Avoid inhaling. Use only with adequate ventilation. Avoid contact with skin, eyes, or clothing. In case of contact, immediately flush skin or eyes with water for at least **15 minutes**. Get medical attention for eyes.

WARNING

Hydraulic fluid ejected under pressure can cause injury to personnel. Hydraulic fluid sprayed into the air is a fire hazard.

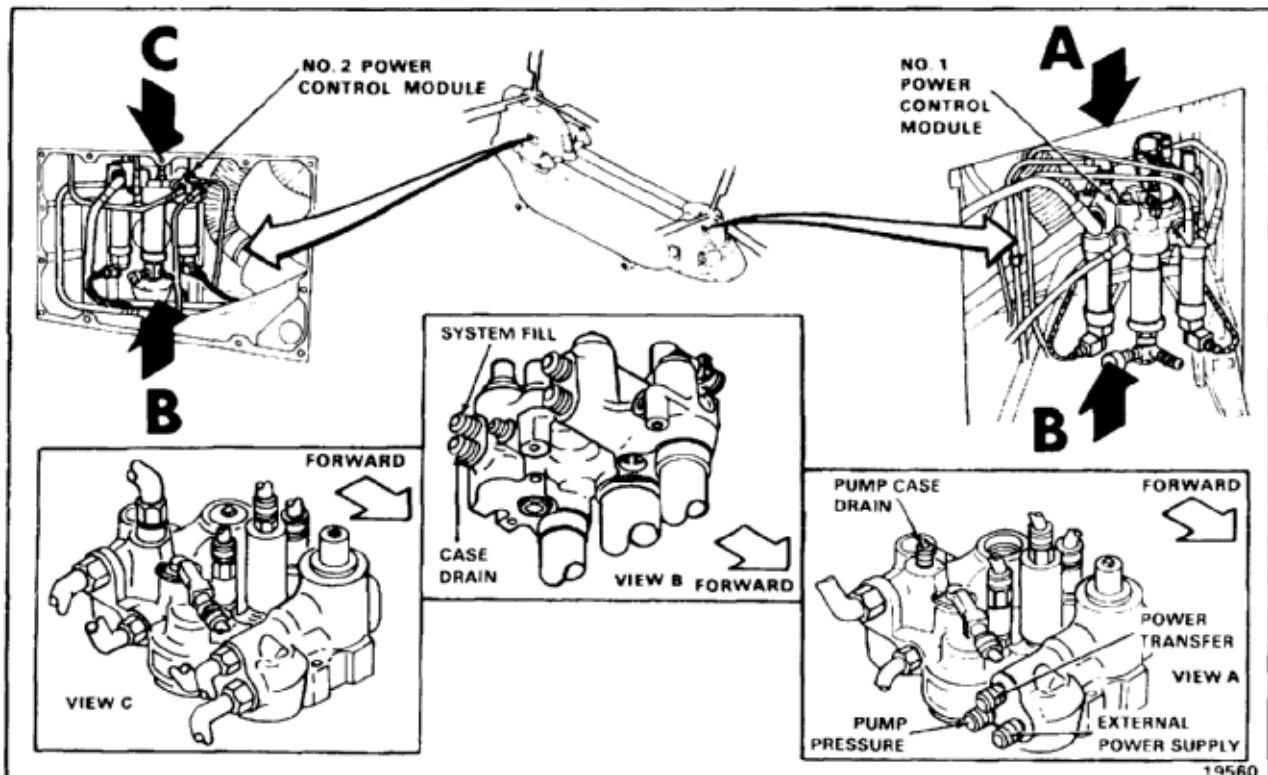

NOTE

The pump case drain check valve installation is shown. Procedure for installation of the system fill, power transfer, pump pressure, case drains, and external power supply check valves is the same.

1. Install packing (1) on check valve (2) as follows:
 - a. Place packing installation tool (3) (refer to table) over port end of check valve (2).
 - b. Submerge check valve (2) and packing (1) in hydraulic fluid (E199).
 - c. Slide packing (1) over tool (3) onto check valve (2).
 - d. Ensure packing (1) is not twisted and is properly installed in groove (4). Remove packing installation tool.

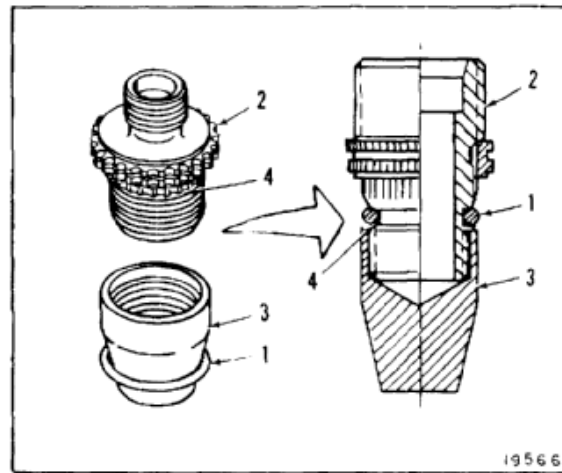

Check Valve	Packing Tool	Combination Wrench and Drive Tool	Lockring Removal Tool	Installation Torque Inch-Pounds
System Fill	ORT-437	RF9806DW	RF9806LPD	180-245
Case Drain	ORT-562	RF9808DW	RF9808LPD	430-510
Pump Case Drain	ORT-1125	RF9816DW	RW9816LPD	1140-1260
Power Transfer	ORT-687	RF9810DW	RW9810LPD	600-680
Pump Pressure	ORT-437	RF9806DW	RW9806LPD	180-245
External Power Supply	ORT-562	RF9808DW	RW9808LPD	430-510

7-54.2 INSTALL NO. 1 OR NO. 2 POWER CONTROL MODULE MISCELLANEOUS CHECK VALVES (Continued)

7-54.2

2. Clean area around port (5). Use dry cleaning solvent (E162). Insert check valve (2) into port (5). Hand-tighten clockwise until check valve is seated.
3. Engage serrations (6) of check valve (2) with proper combination wrench and drive tool from table. Tighten check valve to minimum torque.

NOTE

Upon reinstallation of original check valve, index mark should align.

4. If serrations of check valve (2) and port (5) do not align, slowly increase torque toward maximum value until serrations align. Do not exceed maximum torque value. Remove combination wrench and drive tool.
5. Clean port (5) with solvent. Apply zinc chromate primer (E291) to port and below check valve locking (7), so primer is squeezed out between the external serrations of locking and port during locking installation.
6. Install check valve locking (7) while zinc chromate primer is still wet. Install combination wrench on check valve. Tighten combination wrench until it bottoms on port (5) and seats the locking.

NOTE

Any sudden increase in torque indicates that locking (7) serrations and port (5) serrations are not aligned.

7. Tighten wrench to torque per table. If serrations cannot be aligned, remove combination wrench with locking (7). Repeat step 6.

FOLLOW-ON MAINTENANCE:

- Reconnect pipe/hose (Task 7-4).
- Perform operational check (TM 55-1520-240-T).

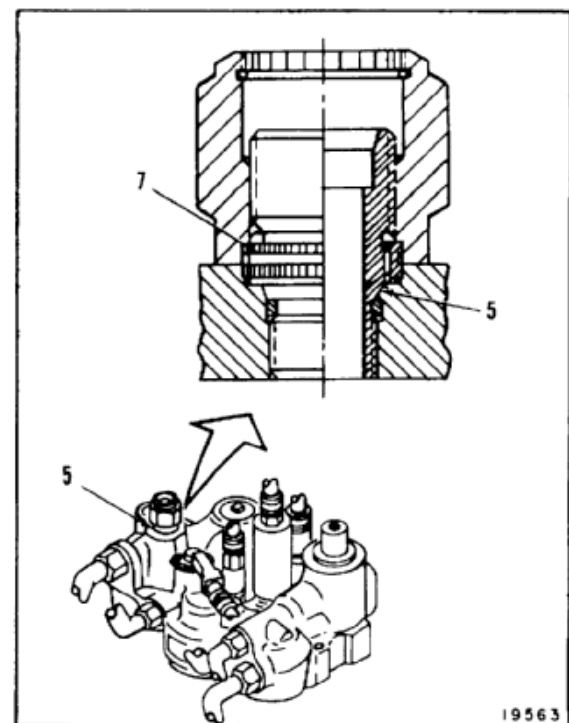
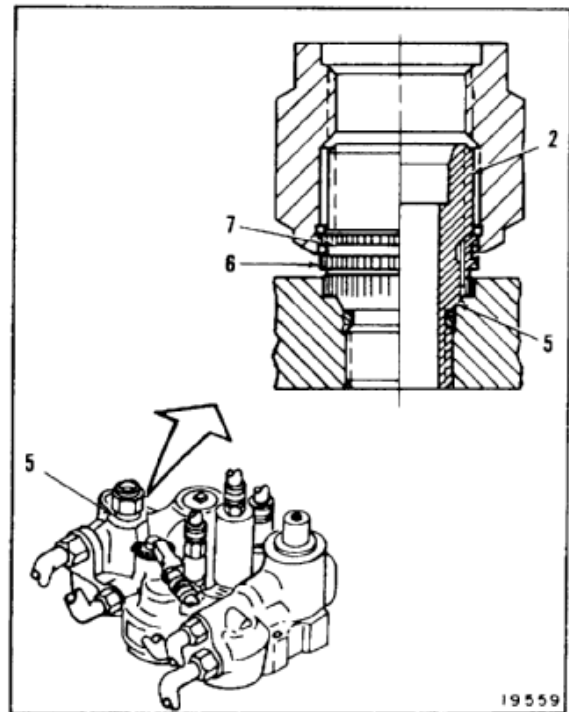

END OF TASK

INITIAL SETUP

Applicable Configurations:

All

Tools:

Aircraft Mechanic's Tool Kit, NSN 5180-00-323-4692

Materials:

Lockwire (E231)

Parts:

Preformed Packings
Retainers

Personnel Required:

Medium Helicopter Repairer
Inspector

References:

TM 55-1520-240-23P

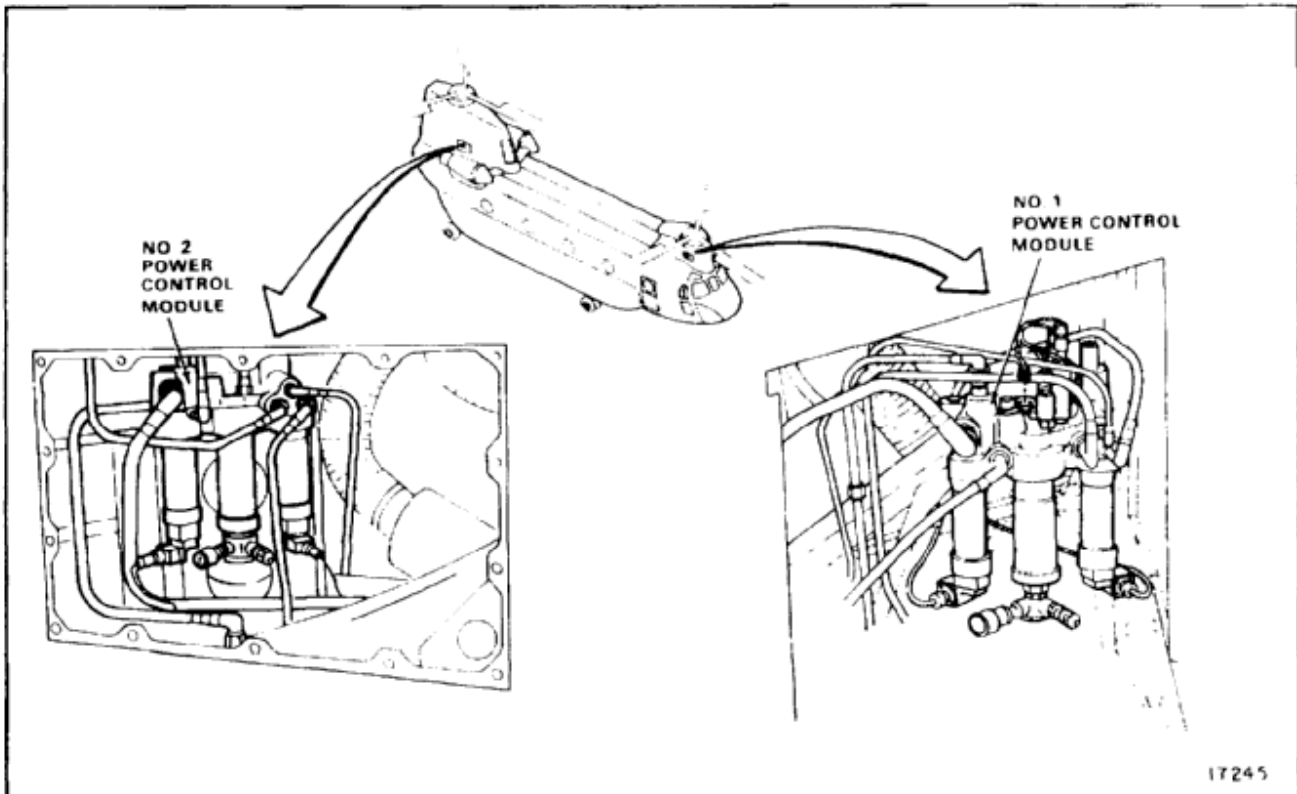

7-55 INSTALL NO. 1 OR NO. 2 POWER CONTROL MODULE PUMP CHANGE INDICATOR (Continued)

7-55

NOTE

There are two pump change indicators, one in No. 1 and one in No. 2 module. Procedure is same to install any pump change indicator. No. 1 module is shown here.

1. Install indicator (1), retainer (2), and two packings (3) in module (4).
2. Install three screws (5) in indicator (1).
3. Lockwire screws (5). Use lockwire (E231).
4. Install connector (6) on indicator (1).
5. Lockwire connector (6). Use lockwire (E231).

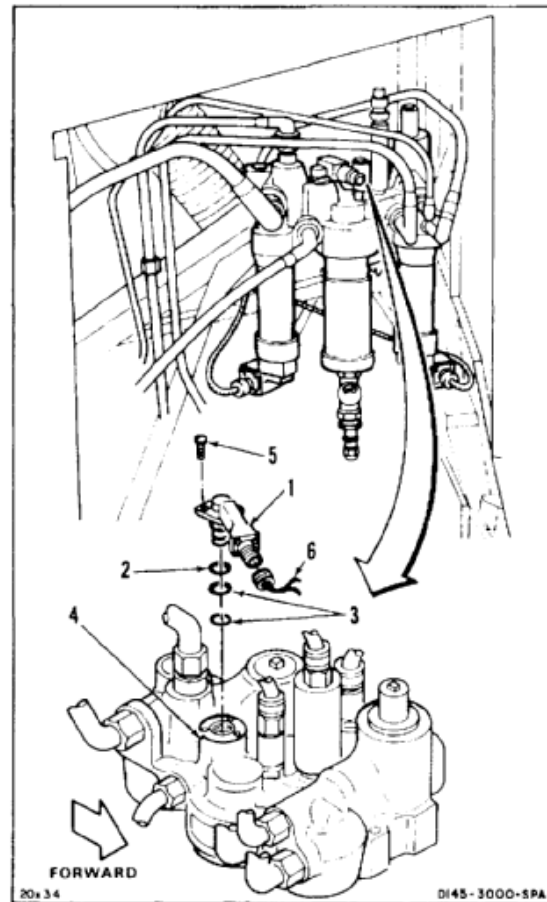
**INSPECT****FOLLOW-ON MAINTENANCE:**

Service flight control system (Task 1-60, 1-61, 1-62, or 1-63).

Perform operational check (TM 55-1520-240-T).

Close right forward work platform or right pylon access door (Task 2-2).

END OF TASK

INITIAL SETUP

General Safety Instructions:

Applicable Configurations:

All

Tools:

Aircraft Mechanic's Tool Kit, NSN 5180-00-323-4692

Materials:

Cloths (E135)

Personnel Required:

Medium Helicopter Repairer

Equipment Condition:

- Battery Disconnected (Task 1-39)
- Electrical Power Off
- Hydraulic Power Off
- Right Forward Work Platform or Right Pylon Access Door Open (Task 2-2)

WARNING

Hydraulic fluid (E199) is toxic. It can irritate skin and cause burns. Avoid inhaling. Use only with adequate ventilation. Avoid contact with skin, eyes, or clothing. In case of contact, immediately flush skin or eyes with water for at least **15 minutes**. Get medical attention for eyes.

WARNING

Hydraulic fluid ejected under pressure can cause injury to personnel. Hydraulic fluid sprayed into the air is a fire hazard.

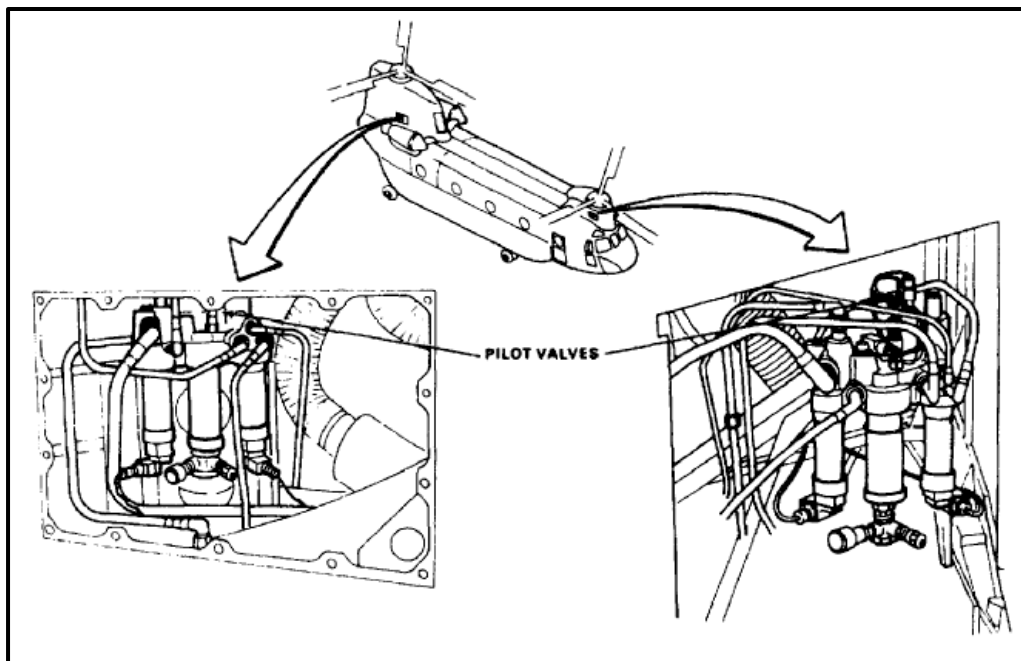

NOTE

There are two pilot valves, one in No. 1 and one in No. 2 module. Procedure is same to remove any pilot valve. No. 1 module is shown here.

1. Disconnect connector (1) from valve (2).
2. Remove lockwire from valve (2). Remove valve, four retainers (3), and three packings (4) from SYS PLT V port (5). Use container and cloths (E135) for spilled fluid.

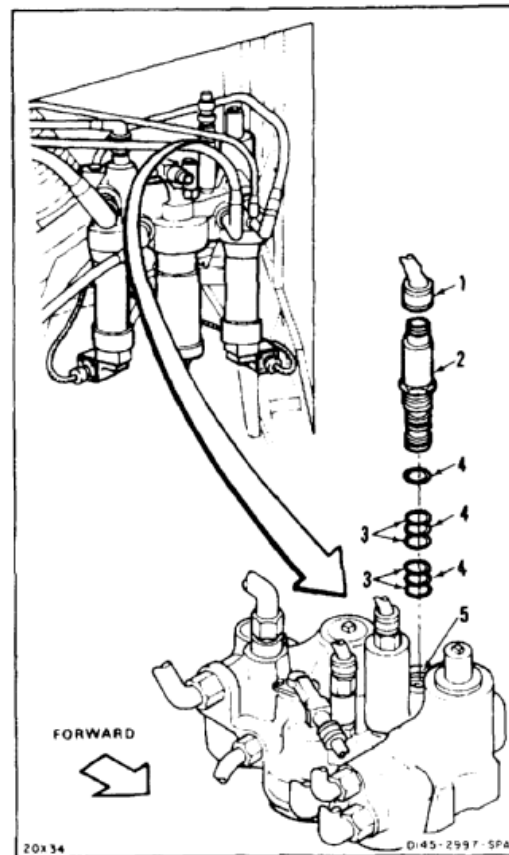
**FOLLOW-ON MAINTENANCE:**

None

END OF TASK

INITIAL SETUP

Applicable Configurations:

All

Tools:

Aircraft Mechanic's Tool Kit, NSN 5180-00-323-4692

Materials:

Lockwire (E231)

Parts:

Preformed Packings
Retainers

Personnel Required:

Medium Helicopter Repairer
Inspector

References:

TM 55-1520-240-23P

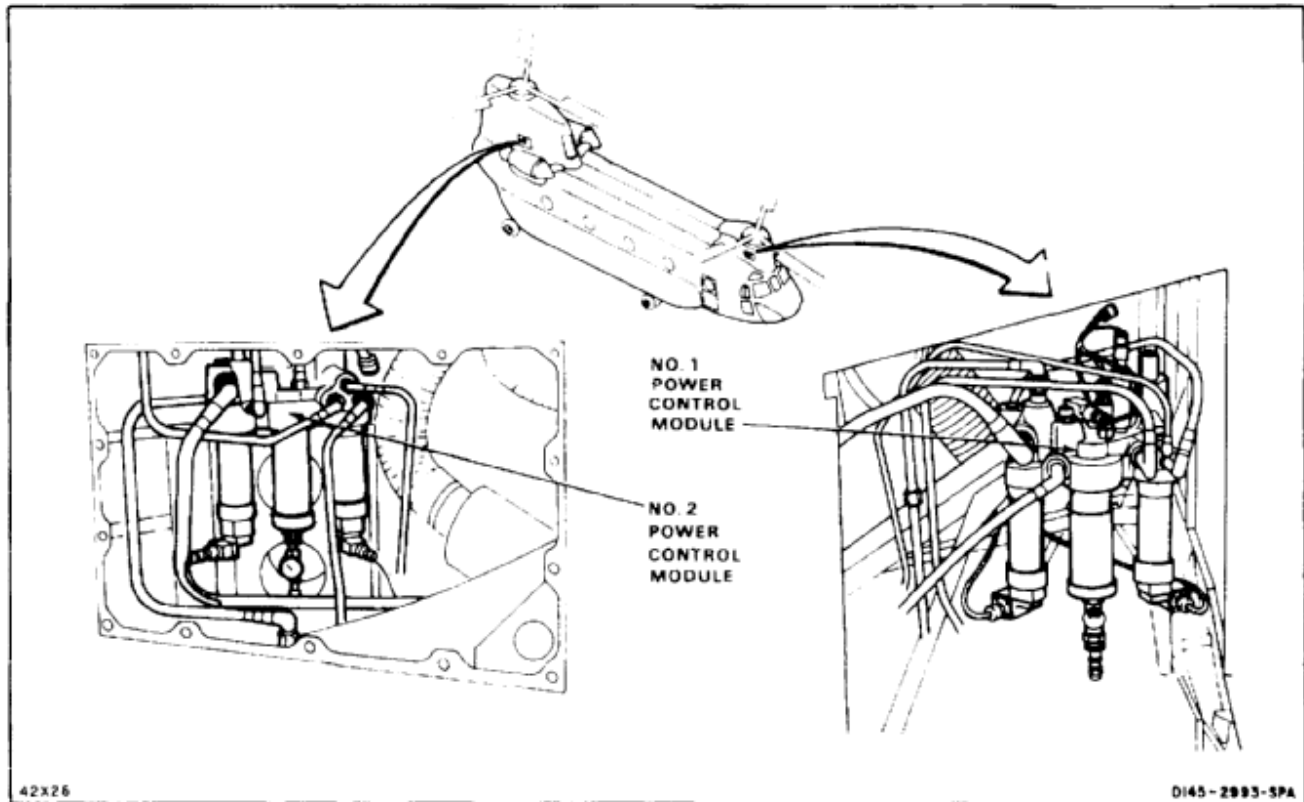

NOTE

There are two pilot valves, one in No. 1 and one in No. 2 module. Procedure is same to install any pilot valve. No. 1 module is shown here.

1. Install valve (1), four retainers (2), and three packings (3) in SYS PLT V port (4).
2. Connect connector (5) to valve (1).
3. Lockwire valve (1) to valve (6). Use lockwire (E231).

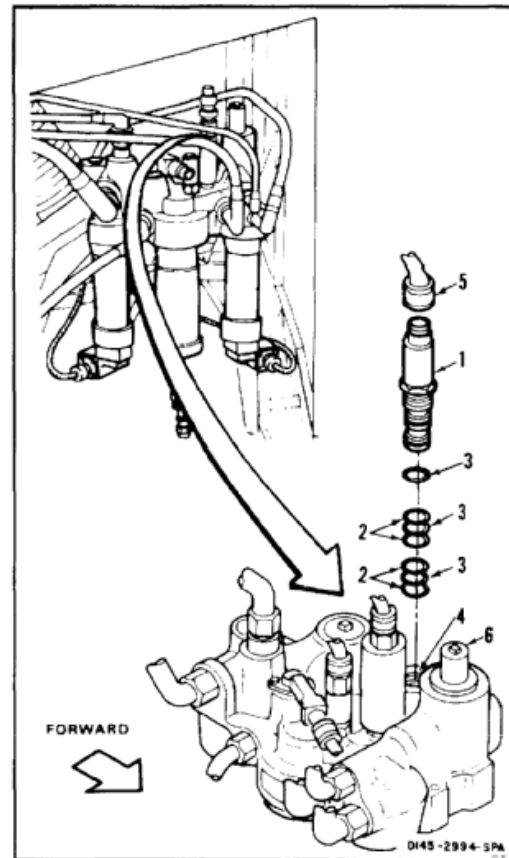
INSPECT**FOLLOW-ON MAINTENANCE:**

- Service flight control system (Task 1-60, 1-61, 1-62, or 1-63).
- Perform operational check (TM 55-1520-240-T).
- Close right forward work platform or right pylon access door (Task 2-2).

END OF TASK

INITIAL SETUP

Applicable Configurations:

All

Tools:

Aircraft Mechanic's Tool Kit, NSN 5180-00-323-4692

Materials:

- Cloths (E135)
- Gloves (E186)
- Tags (E264)

Personnel Required:

Medium Helicopter Repairer (2)

References:

TM 1-1520-253-23

Equipment Condition:

- Battery Disconnected (Task 1-39)
- Electrical Power Off
- Hydraulic Power Off
- Utility Hydraulic System Depressurized (Task 7-135.1)
- Flight Boost Reservoir Drained (Task 1-60.1 or 1-61.1)
- Right Forward Work Platform or Pylon Access Doors Open (Task 2-2)

General Safety Instructions:

WARNING

Hydraulic fluid (E199) is toxic. It can irritate skin and cause burns. Avoid inhaling. Use only with adequate ventilation. Avoid contact with skin, eyes, or clothing. In case of contact, immediately flush skin or eyes with water for at least **15 minutes**. Get medical attention for eyes.

WARNING

Hydraulic fluid ejected under pressure can cause injury to personnel. Hydraulic fluid sprayed into the air is a fire hazard.

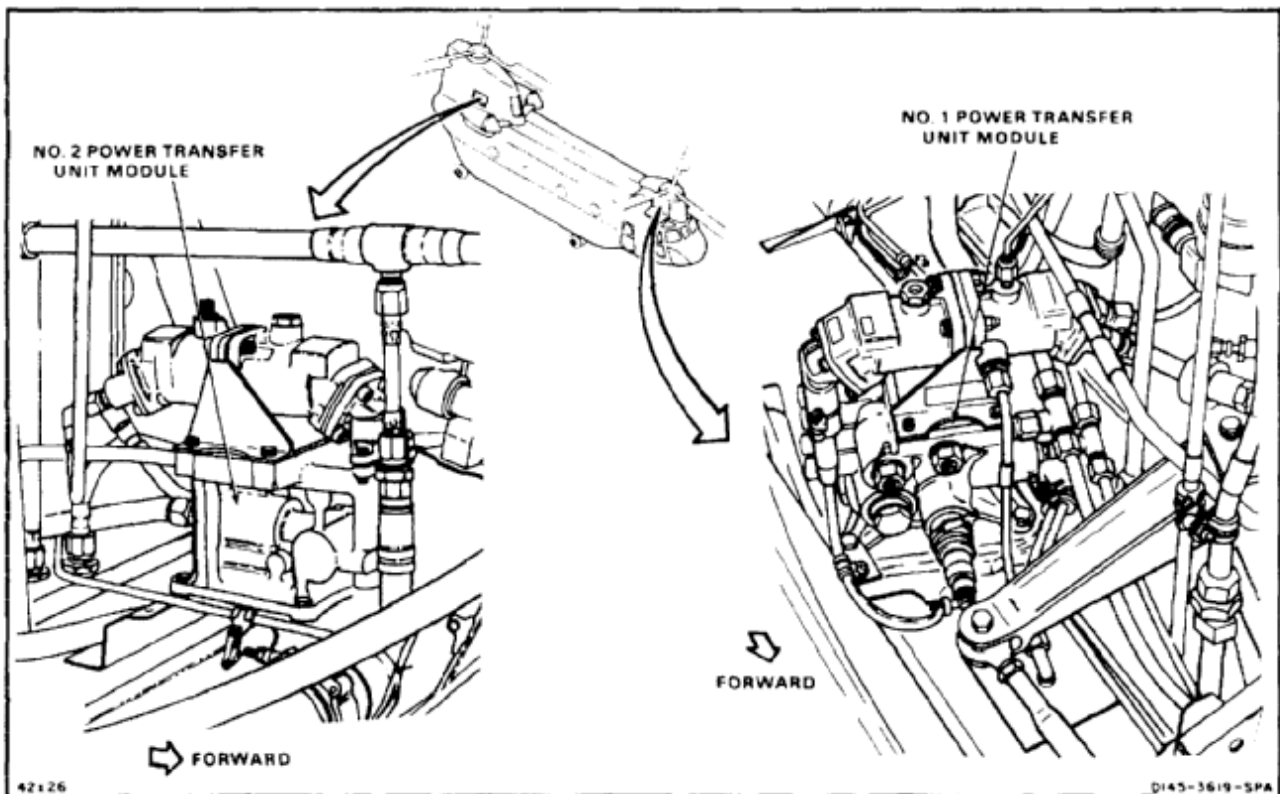

NOTE

Procedure is same to remove No. 1 or No. 2 power transfer module. No. 1 module is shown here.

NOTE

If a crack in the power transfer units is suspected during removal, refer to TM 1-1520-253-23.

1. Tag and disconnect two tubes (1) from module (2). Use tag (E264). Use cloths (E135) for spilled fluid. Use gloves (E186).
2. Tag and disconnect two tees (3) from module (2). Use tag (E264). Use container and cloths (E135) for spilled fluid.
3. Tag and disconnect two tubes (4) from module (2). Use tag (E264). Use cloths (E135) for spilled fluid.
4. Disconnect connector (5) from valve (6).
5. Remove four bolts (7) and washers (8).
6. Remove module (2).

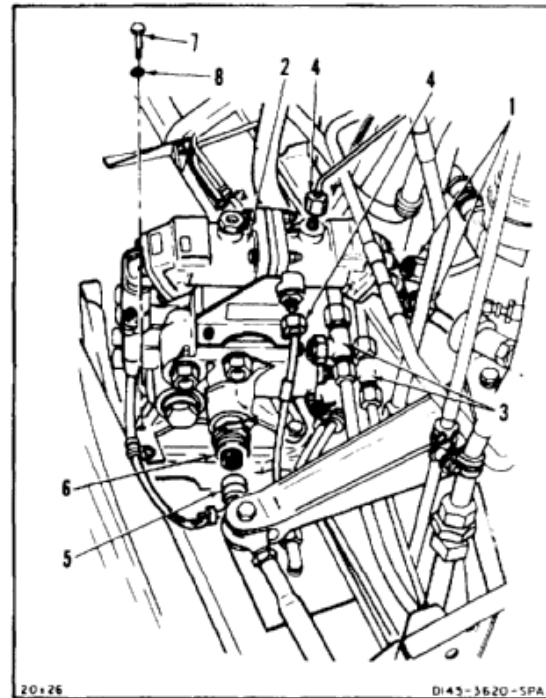
**FOLLOW-ON MAINTENANCE:**

None

END OF TASK

INITIAL SETUP

Applicable Configurations:

All

Tools:

Aircraft Mechanic's Tool Kit, NSN 5180-00-323-4692
 Torque Wrench, 30 to 150 Inch-Pounds
 Hand Oiler

Materials:

Hydraulic Fluid (E199)
 Lockwire (E231)

Parts:

Prefomed Packings

Personnel Required:

Medium Helicopter Repairer
 Inspector

References:

TM 55-1520-240-23P

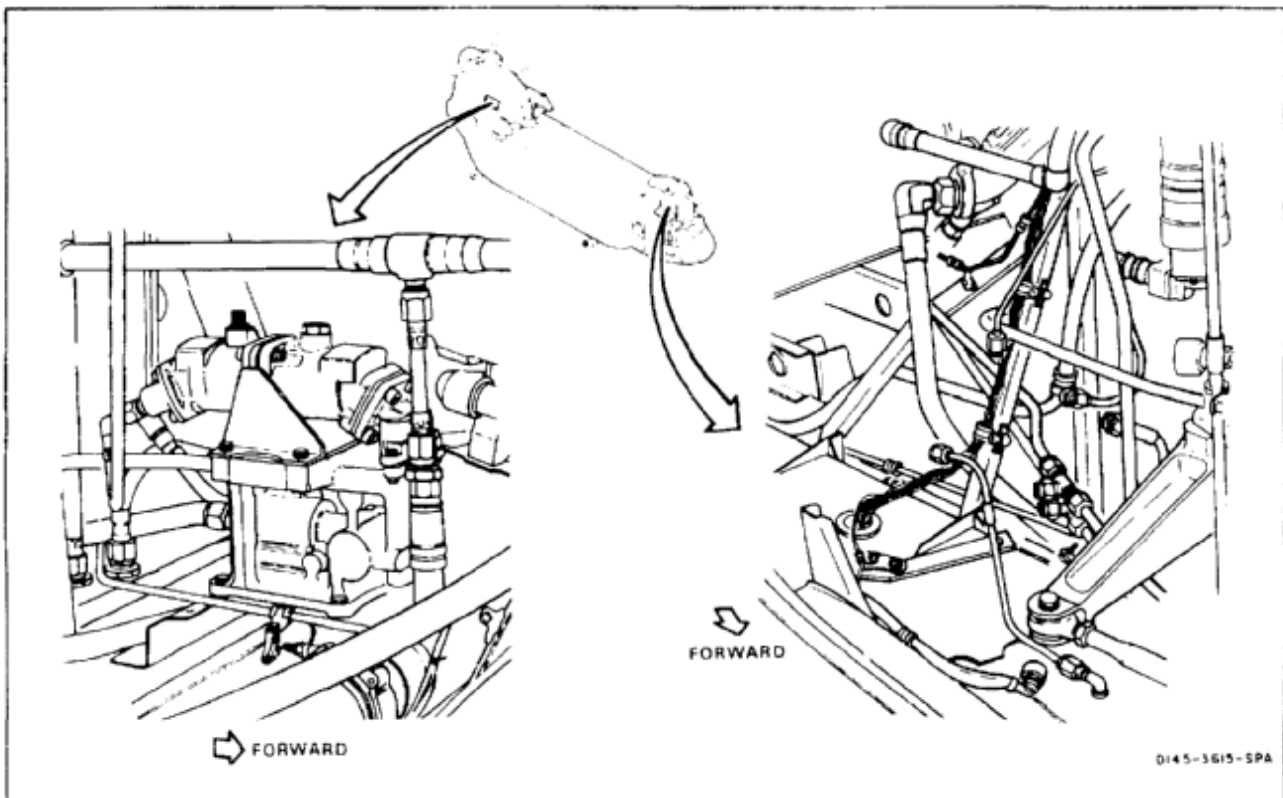

NOTE

Procedure is same to install No. 1 or No. 2 power transfer module. No. 1 module is shown here.

1. Position module (1) on structure (2). Install four bolts (3) and washers (4). Do not tighten bolts at this time.
2. Connect tube (5) to SEAL DRAIN port (6). Remove tag.
3. Connect tube (7) to DRAIN port (8). Remove tag.
4. Connect tee (9) to flow limiter (10).
5. Connect tee (11) to RETURN port (12).
6. Connect tube (13) to INLET port (14). Remove tag.
7. Connect tube (15) to PRESS port (16). Remove tag.
8. Connect connector (17) to SOL PLT VALVE (18).
9. Torque bolts (3) to **60 inch-pounds**.

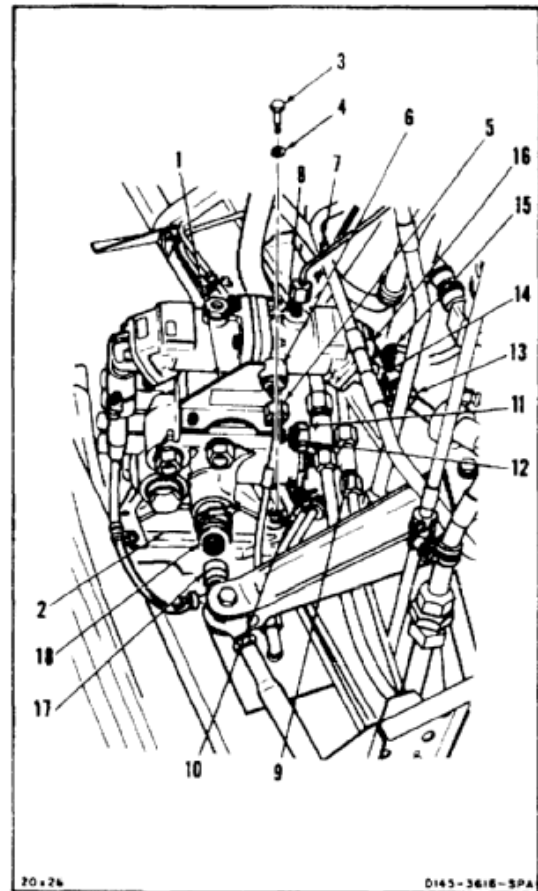

10. Remove lockwire from plug (19). Remove plug and packing (20) from motor (21).
11. Fill motor (21) with hydraulic fluid (E199). Use hand oiler.
12. Install plug (19) and packing (20) in motor (21).
13. Lockwire plug (19) to module (1). Use lockwire (E231).

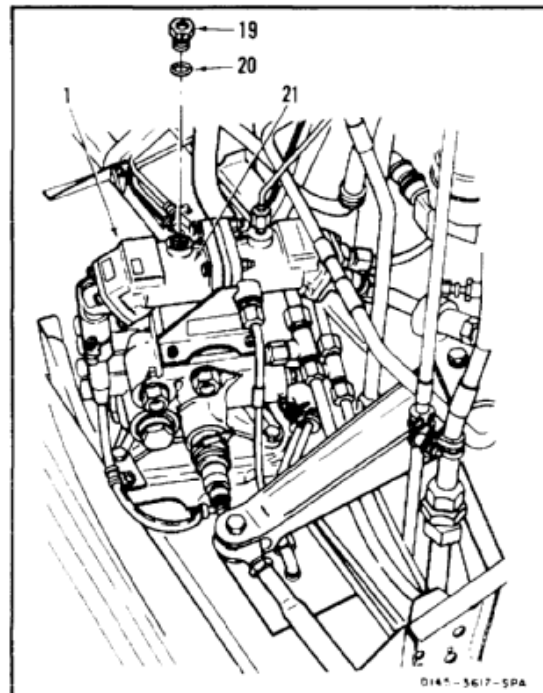
INSPECT**FOLLOW-ON MAINTENANCE:**

- Service reservoir (Task 1-60, 1-61, or 1-62).
- Bleed utility hydraulic system (Task 7-334).
- Perform operational check (TM 55-1520-240-T).
- Close right forward work platform or pylon access doors (Task 2-2).

END OF TASK

INITIAL SETUP

Applicable Configurations:

All

Tools:

Aircraft Mechanic's Tool Kit, NSN 5180-00-323-4692

Materials:

Cloths (E135)
Gloves (E186)

Personnel Required:

Medium Helicopter Repairer

Equipment Condition:

- Battery Disconnected (Task 1-39)
- Electrical Power Off
- Hydraulic Power Off
- Utility Hydraulic System Depressurized (Task 7-135.1)
- Reservoir Drained (Task 1-60.1 or 1-61.1)
- Right Forward Work Platform or Pylon Access Doors Open (Task 2-2)

General Safety Instructions:

WARNING

Hydraulic fluid (E199) is toxic. It can irritate skin and cause burns. Avoid inhaling. Use only with adequate ventilation. Avoid contact with skin, eyes, or clothing. In case of contact, immediately flush skin or eyes with water for at least **15 minutes**. Get medical attention for eyes.

WARNING

Hydraulic fluid ejected under pressure can cause injury to personnel. Hydraulic fluid sprayed into the air is a fire hazard.

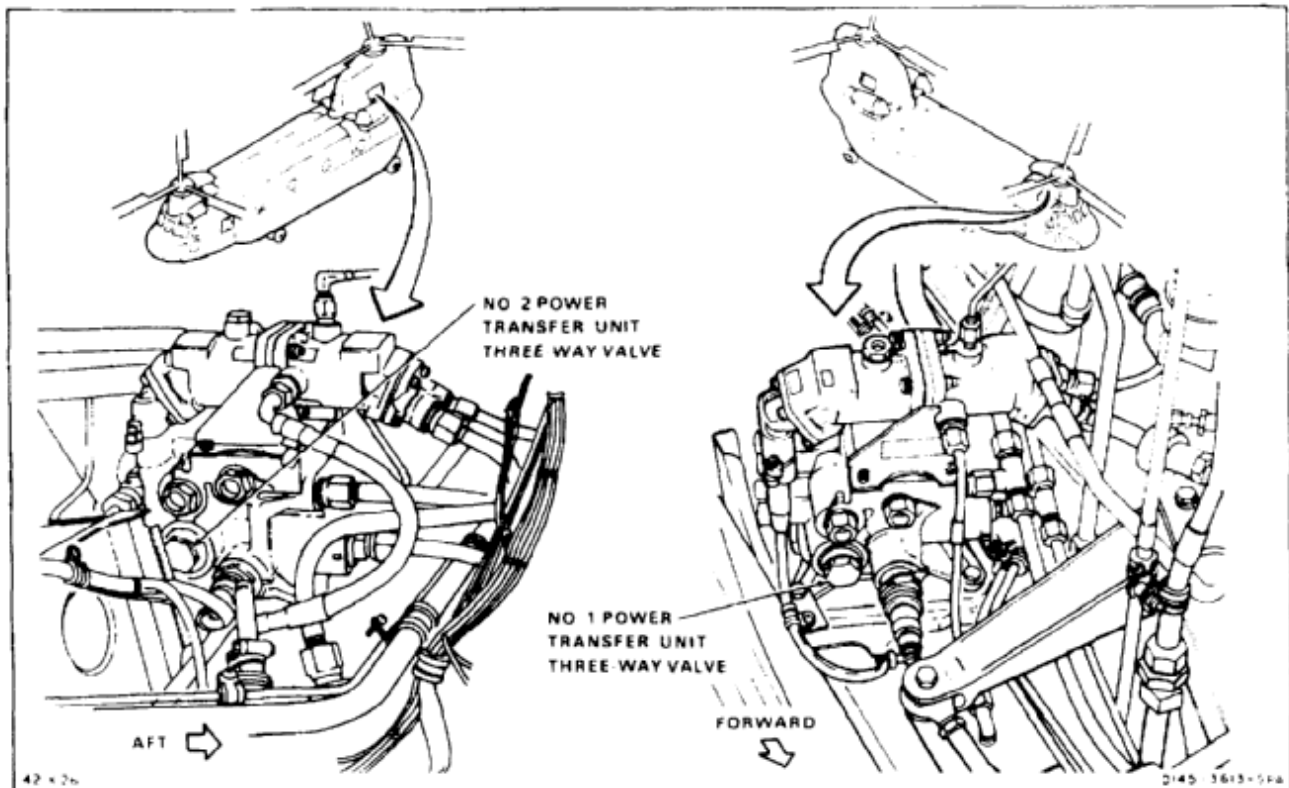

NOTE

Procedure is same to remove three-way valve in No. 1 or No. 2 transfer unit. No. 1 unit is shown here.

1. Remove lockwire from valve (1).
2. Remove valve (1), six retainers (2), and three packings (3) from housing (4). Use cloths (E135) for spilled fluid. Use gloves (E186).

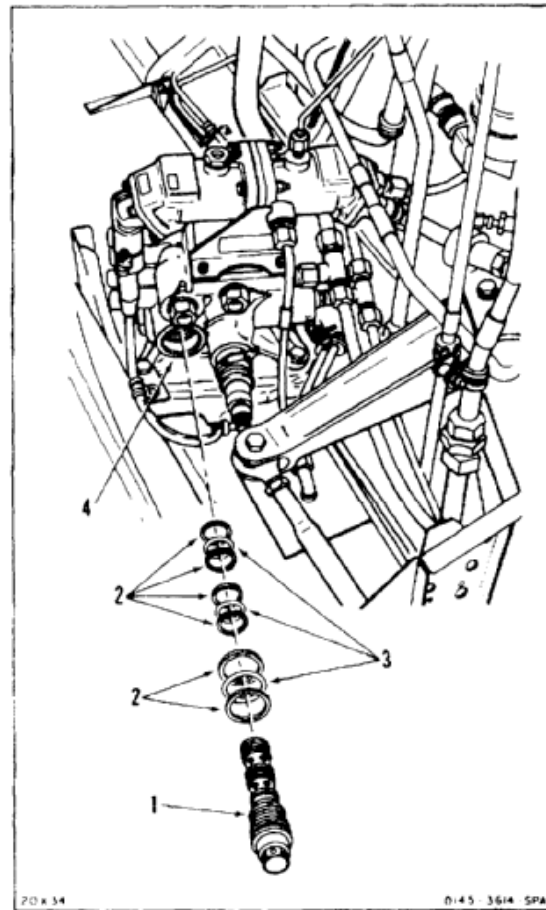
**FOLLOW-ON MAINTENANCE:**

None

END OF TASK

7-282

7-61 INSTALL POWER TRANSFER UNIT THREE-WAY VALVE

7-61

INITIAL SETUP

Applicable Configurations:

All

Tools:

Aircraft Mechanic's Tool Kit, NSN 5180-00-323-4692
 Torque Wrench, 0 to 150 Inch-Pounds
 Hand Oiler

Materials:

Hydraulic Fluid (E199)
 Cloths (E135)
 Lockwire (E231)

Parts:

Packings
 Retainers

Personnel Required:

Medium Helicopter Repairer
 Inspector

References:

TM 55-1520-240-23P

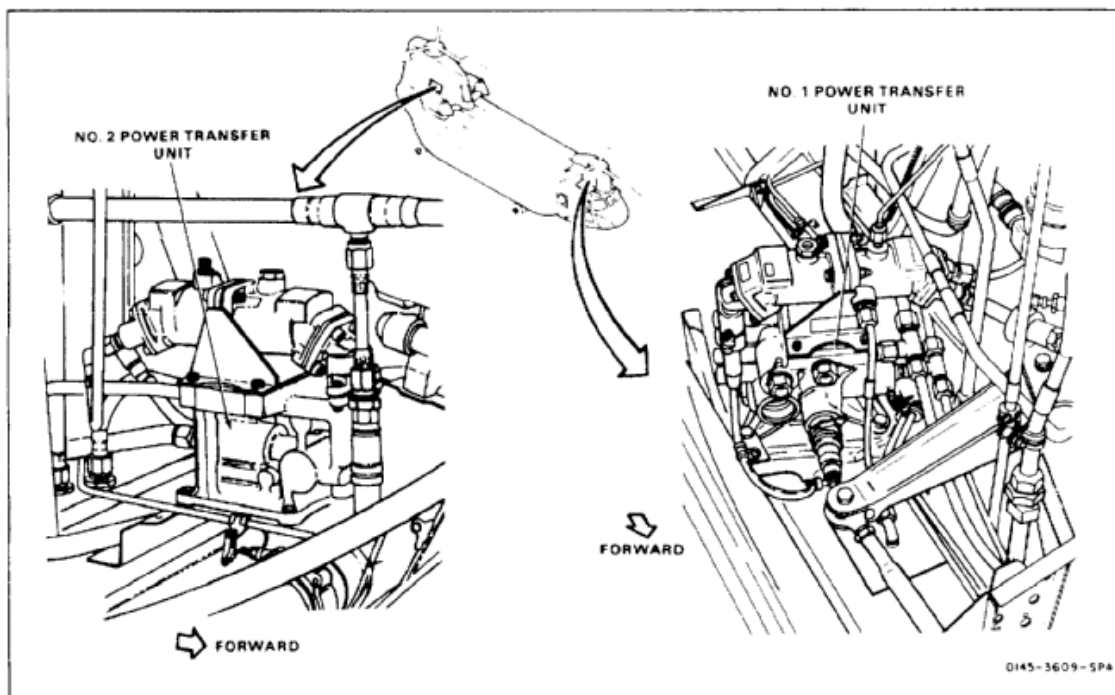

NOTE

Procedure is same to install three-way valve in No. 1 or No. 2 transfer unit.
No. 1 unit is shown here.

1. Install two retainers (1) and packing (2) on valve (3).
2. Install four retainers (4) and two packings (5) on valve (3).
3. Install valve (3), in PRESS OPR VALVE port (6). Torque valve to **60 inch-pounds**.
4. Lockwire valve (3) to housing (7). Use lockwire (E231).

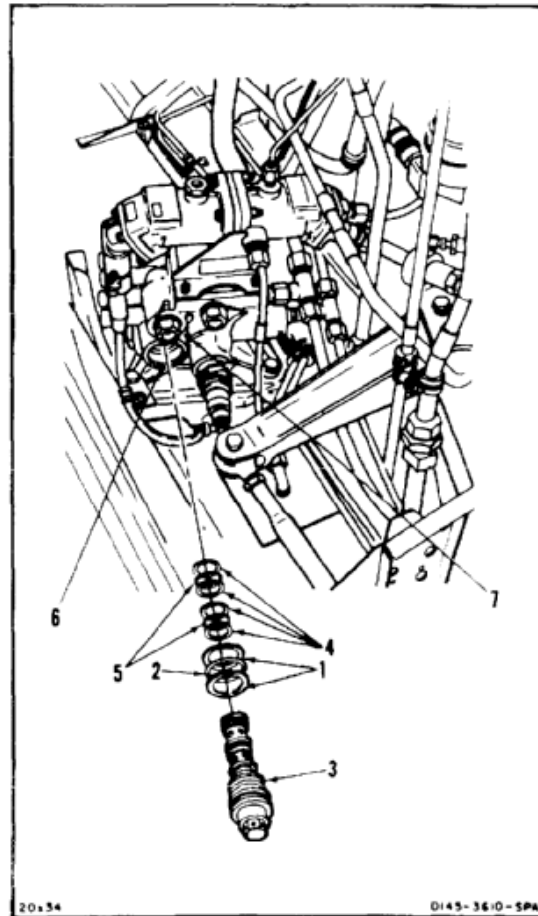

20x34

D145-3610-SPA

5. Remove lockwire from plug (8). Remove plug (8) and packing (9) from port (10).

WARNING

Hydraulic fluid (E199) is toxic. It can irritate skin and cause burns. Avoid inhaling. Use only with adequate ventilation. Avoid contact with skin, eyes, or clothing. In case of contact, immediately flush skin or eyes with water for at least **15 minutes**. Get medical attention for eyes.

6. Fill motor (11) through port (10) with hydraulic fluid (E199). Use hand oiler. Use cloths (E135) for spilled hydraulic fluid.
7. Install plug (8) and packing (9) in port (10).
8. Lockwire plug (8) to unit (12). Use lockwire (E231).

INSPECT

FOLLOW-ON MAINTENANCE:

Service reservoir (Task 1-60, 1-61, or 1-62).
 Bleed utility hydraulic system (Task 7-334).
 Perform operational check (TM 55-1520-240-T).
 Close forward work platform or pylon access doors (Task 2-2).

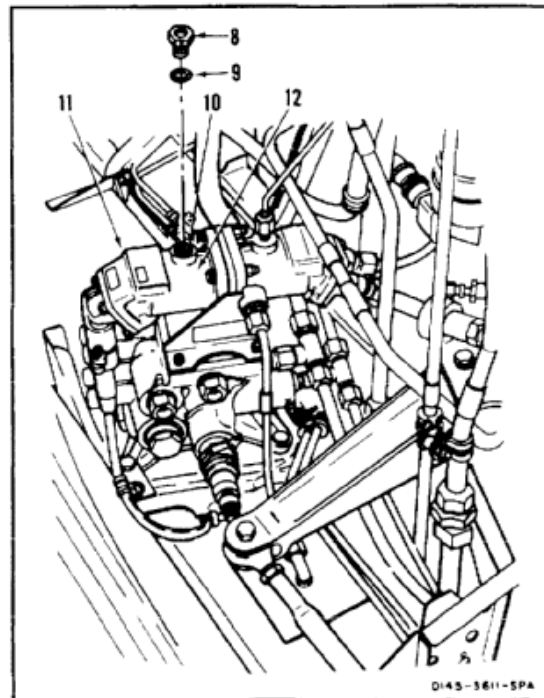

END OF TASK

INITIAL SETUP

Applicable Configurations:

All

Tools:

Aircraft Mechanic's Tool Kit, NSN 5180-00-323-4692

Materials:

Cloths (E135)
Gloves (E186)

Personnel Required:

Medium Helicopter Repairer

Equipment Condition:

Battery Disconnected (Task 1-39)
Electrical Power Off
Hydraulic Power Off
Utility Hydraulic System Depressurized (Task 7-135.1)
Reservoir Drained (Task 1-60.1 or 1-61.1)
Right Forward Work Platform or Pylon Access Doors Open (Task 2-2)

General Safety Instructions:

WARNING

Hydraulic fluid (E199) is toxic. It can irritate skin and cause burns. Avoid inhaling. Use only with adequate ventilation. Avoid contact with skin, eyes, or clothing. In case of contact, immediately flush skin or eyes with water for at least **15 minutes**. Get medical attention for eyes.

WARNING

Hydraulic fluid ejected under pressure can cause injury to personnel. Hydraulic fluid sprayed into the air is a fire hazard.

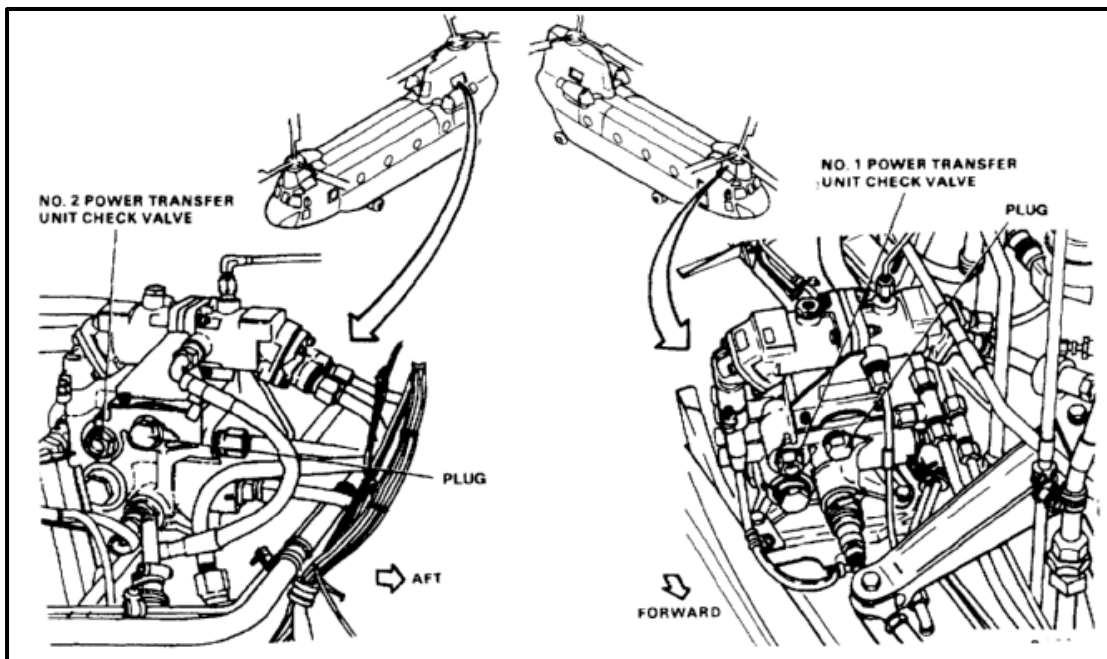

NOTE

There are two check valves, one in No. 1 and one in No. 2 unit. Procedure is same to remove either check valve. No. 1 unit check valve is shown here.

1. Remove lockwire from valve (1).
2. Remove valve (1), four retainers (2), and two packings (3) from housing (4). Use cloths (E135) for spilled fluid. Use gloves (E186).

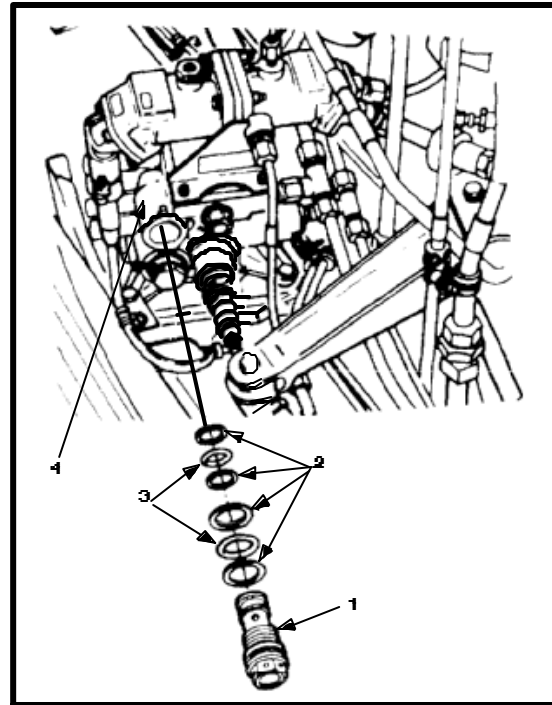
**FOLLOW-ON MAINTENANCE:**

None

END OF TASK

INITIAL SETUP

Applicable Configurations:

All

Tools:

Aircraft Mechanic's Tool Kit, NSN 5180-00-323-4692
Torque Wrench, 0 to 150 Inch-Pounds

Materials:

Cloths (E135)
Lockwire (E231)
Hydraulic Fluid (E199)
Gloves (E186)

Parts:

Packings
Retainers

Personnel Required:

Medium Helicopter Repairer
Inspector

References:

TM 55-1520-240-23P

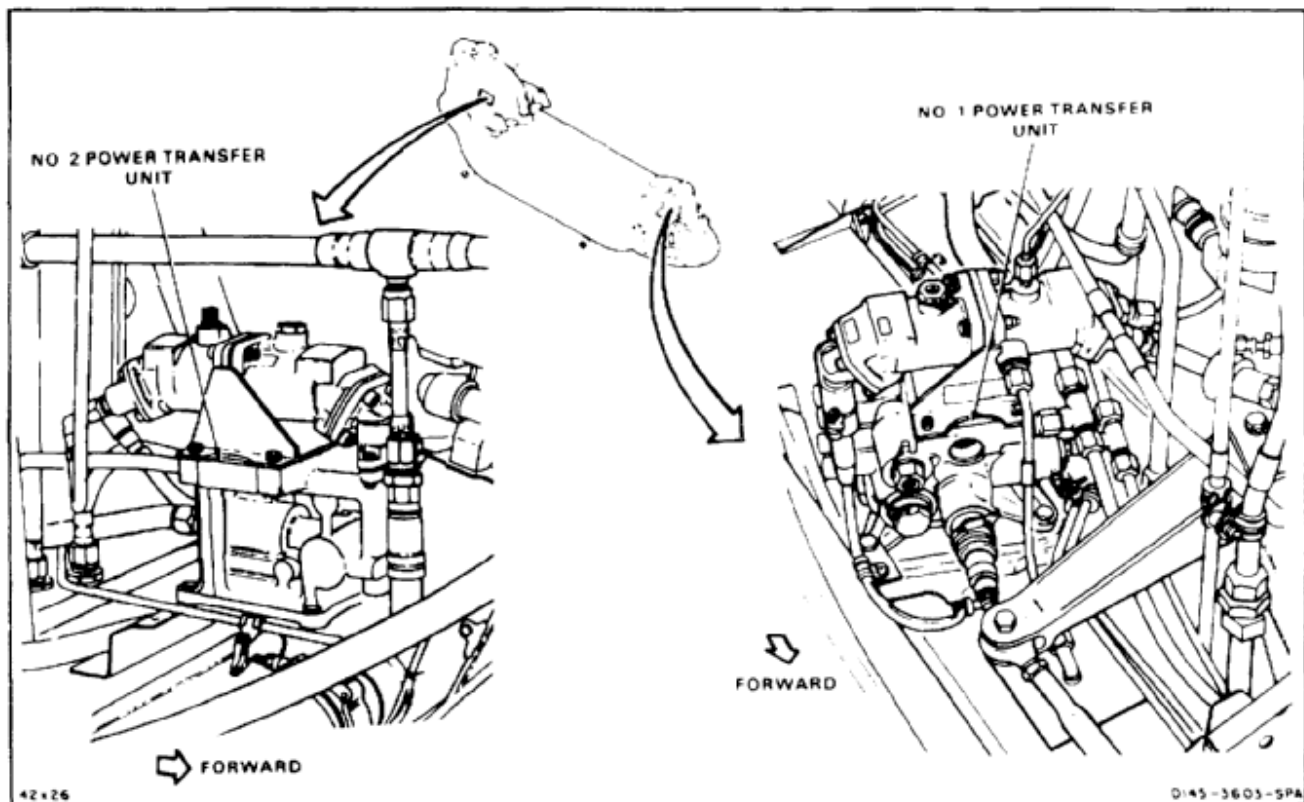

NOTE

There are two check valves, one in No. 1 and one in No. 2 unit. Procedure is same to remove either check valve. No. 1 unit check valve is shown here.

1. Install two retainers (1), packing (2), two retainers (3), and packing (4) on valve (5).
2. Install valve (5), in port (6). Torque valve to **60 inch-pounds**.
3. Lockwire valve (5). Use lockwire (E231).

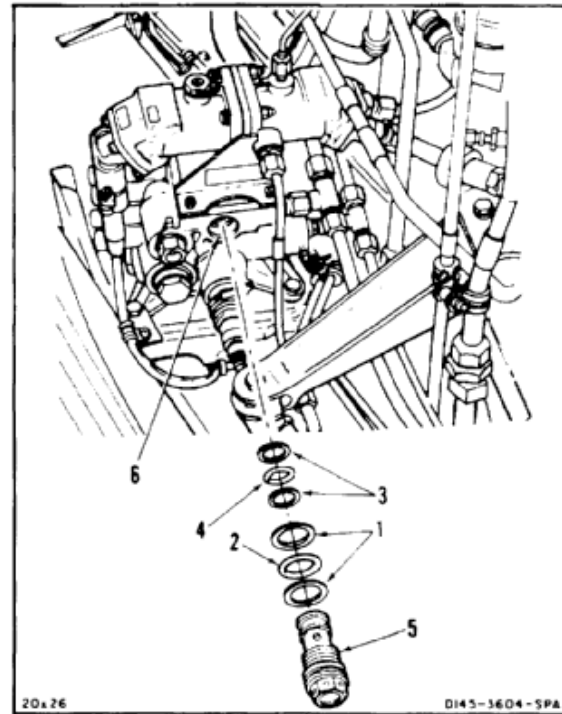

4. Remove lockwire from plug (7). Remove plug and packing (8) from port (9).
5. Fill motor (10) through port (9) with fluid (E199). Use cloths (E135) for spilled fluid. Use gloves (E186).
6. Install plug (7) and packing (8) in port (9).
7. Lockwire plug (7) to unit (11). Use lockwire (E231).

INSPECT**FOLLOW-ON MAINTENANCE:**

Service reservoir (Task 1-60, 1-61, or 1-62).
 Bleed utility hydraulic system (Task 7-334).
 Perform operational check (TM 55-1520-240-T).
 Close right forward work platform or pylon access doors (Task 2-2).

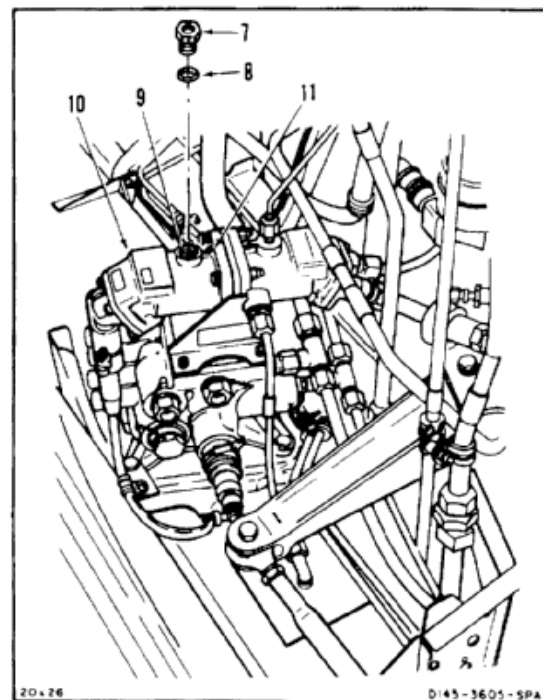

END OF TASK

INITIAL SETUP

Applicable Configurations:

All

Tools:

Aircraft Mechanic's Tool Kit, NSN 5180-00-323-4692

Materials:Cloths (E135)
Gloves (E186)**Personnel Required:**

Medium Helicopter Repairer

Equipment Condition:Battery Disconnected (Task 1-39)
Electrical Power Off
Hydraulic Power Off
Utility Hydraulic System Depressurized (Task 7-135.1)
Reservoir Drained (Task 1-60.1 or 1-61.1)
Right Forward Work Platform or Pylon Access Doors
Open (Task 2-2)**General Safety Instructions:****WARNING**

Hydraulic fluid (E199) is toxic. It can irritate skin and cause burns. Avoid inhaling. Use only with adequate ventilation. Avoid contact with skin, eyes, or clothing. In case of contact, immediately flush skin or eyes with water for at least **15 minutes**. Get medical attention for eyes.

WARNING

Hydraulic fluid ejected under pressure can cause injury to personnel. Hydraulic fluid sprayed into the air is a fire hazard.

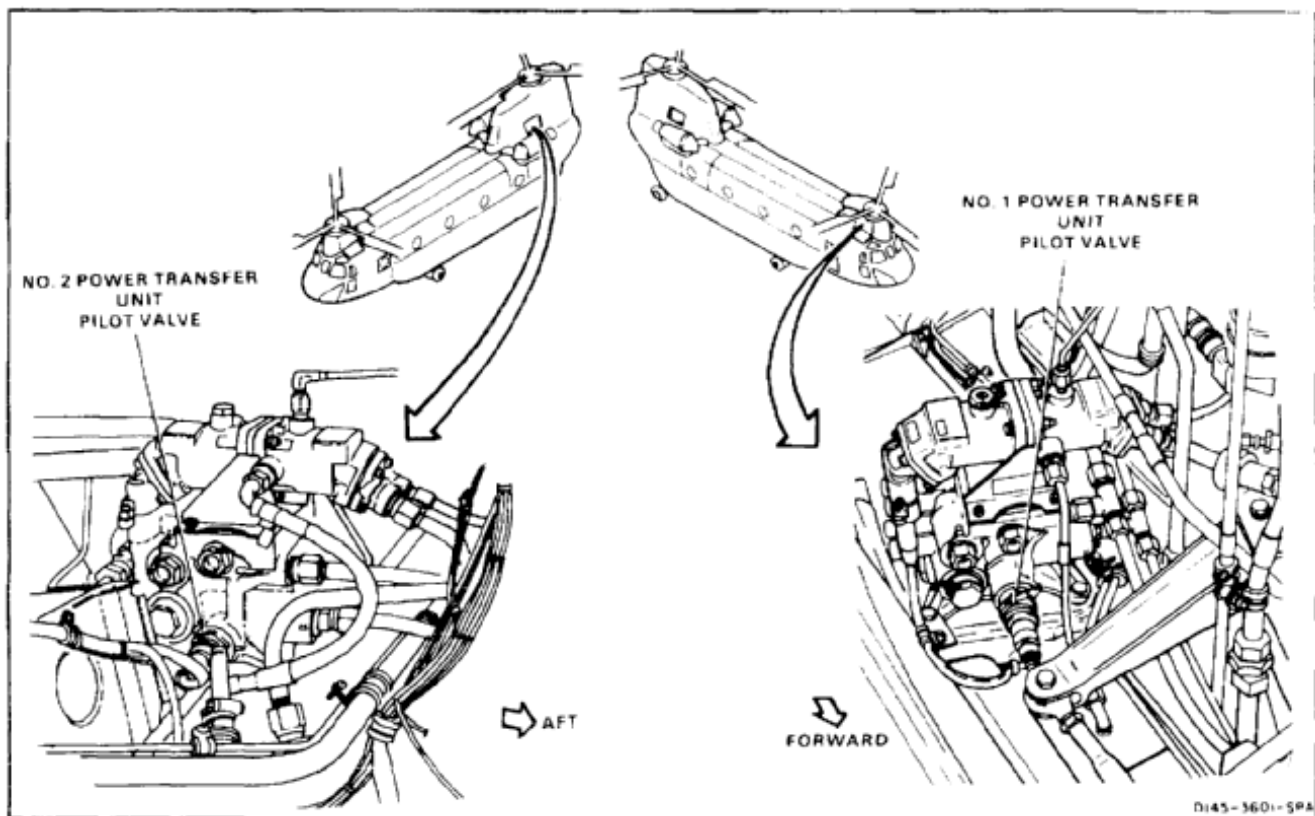

NOTE

Procedure is same to remove pilot valve in No. 1 or No. 2 unit. No. 1 unit is shown here.

1. Disconnect connector (1) from valve (2). Use gloves (E186).
2. Remove lockwire from valve (2).
3. Remove valve (2), six retainers (3), and three packings (4) from housing (5).

FOLLOW-ON MAINTENANCE:

None

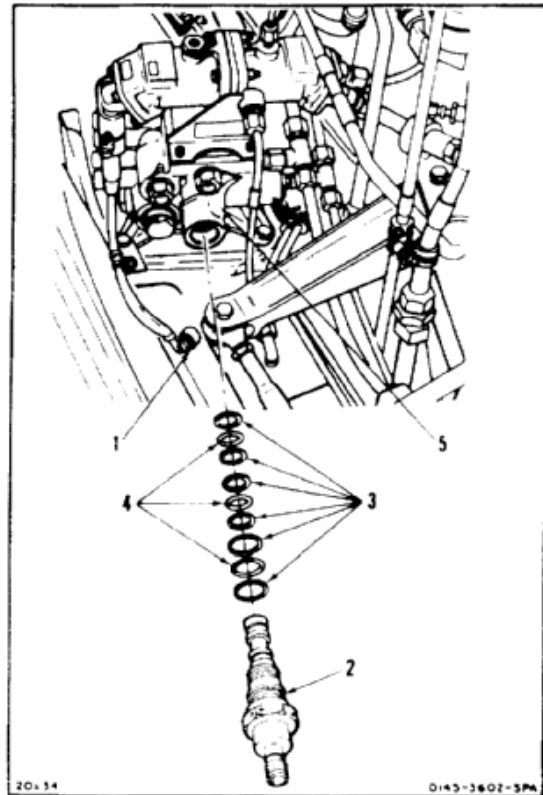

END OF TASK

INITIAL SETUP

Applicable Configurations:

All

Tools:

Aircraft Mechanic's Tool Kit, NSN 5180-00-323-4692
Torque Wrench, 0 to 150 Inch-Pounds

Materials:

Cloths (E135)
Hydraulic Fluid (E199)
Lockwire (E231)
Gloves (E186)

Parts:

Packings
Retainers

Personnel Required:

Medium Helicopter Repairer
Inspector

References:

TM 55-1520-240-23P

General Safety Instructions:

WARNING

Hydraulic fluid (E199) is toxic. It can irritate skin and cause burns. Avoid inhaling. Use only with adequate ventilation. Avoid contact with skin, eyes, or clothing. In case of contact, immediately flush skin or eyes with water for at least **15 minutes**. Get medical attention for eyes.

WARNING

Hydraulic fluid ejected under pressure can cause injury to personnel. Hydraulic fluid sprayed into the air is a fire hazard.

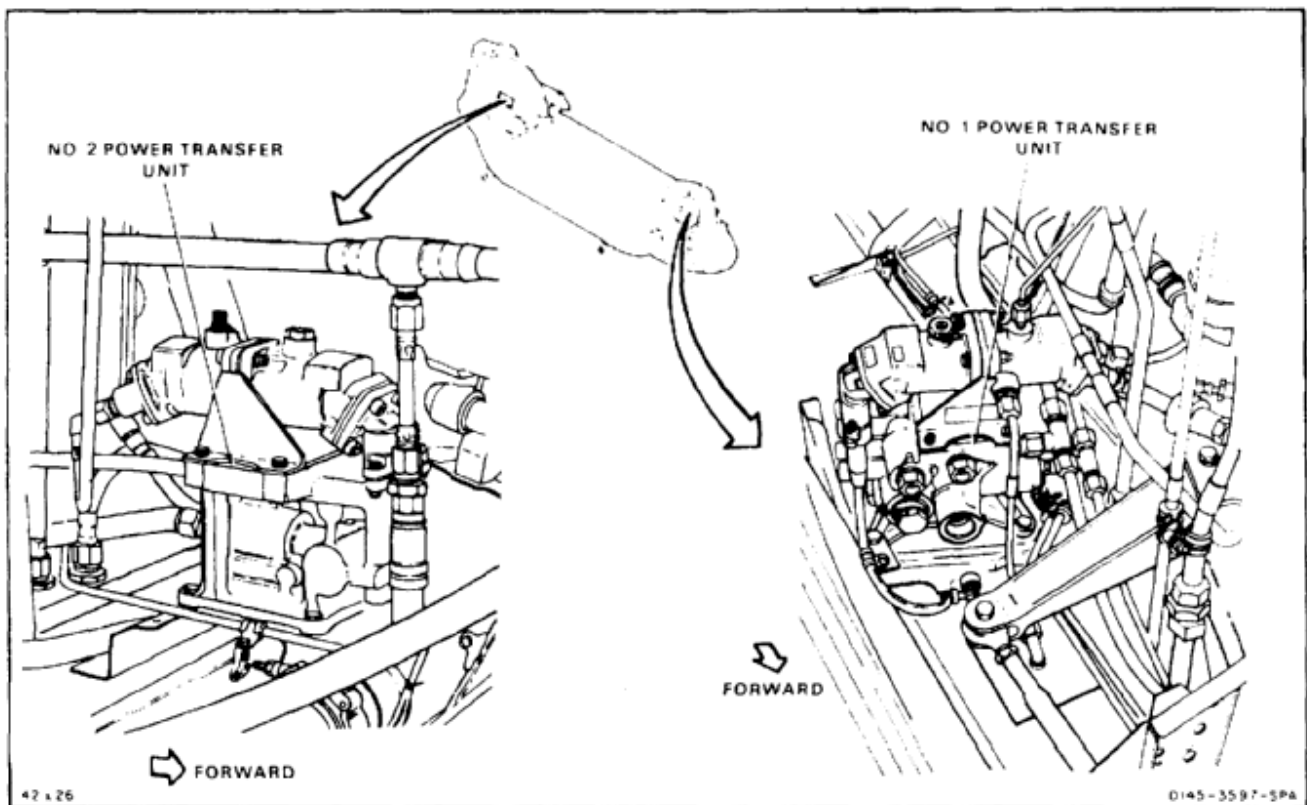

NOTE

Procedure is same to install pilot valve in No. 1 or No. 2 unit. No. 1 unit is shown here.

1. Install two retainers (1), packing (2), four retainers (3), and two packings (4) on valve (5).
2. Install valve (5) in SOL PLT VALVE port (6). Torque valve to **60 inch-pounds**.
3. Connect connector (7) to valve (5).
4. Lockwire valve (5) to housing (8). Use lockwire (E231).

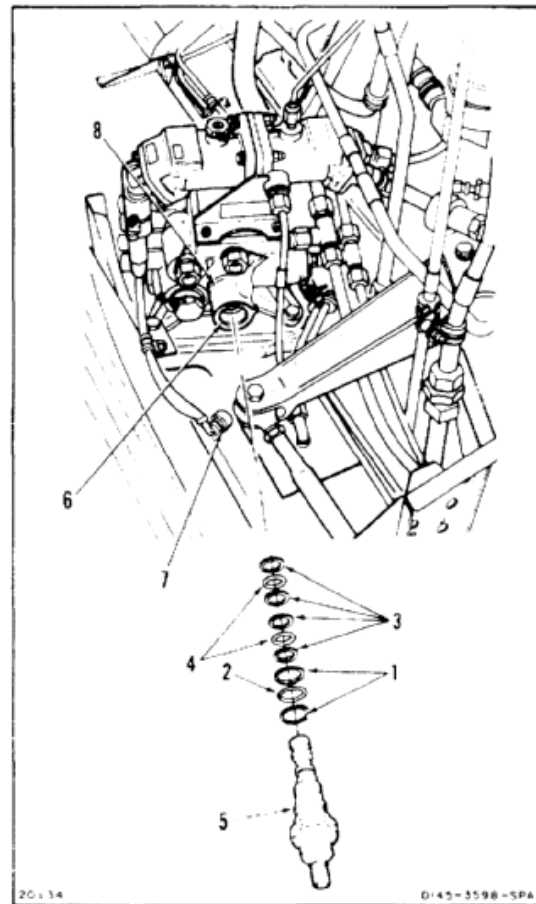

5. Remove lockwire from plug (9). Remove plug and packing (10) from port (11).
6. Fill motor (12) through port (11) with fluid (E199). Use cloths (E135) for spilled fluid. Use gloves (E186).
7. Install plug (9) and packing (10) in port (11).
8. Lockwire plug (9) to module (3). Use lockwire (E231).

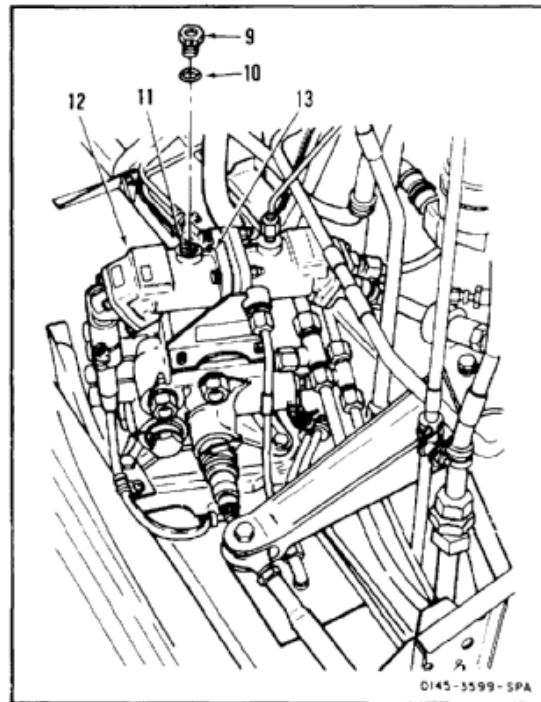
INSPECT**FOLLOW-ON MAINTENANCE:**

- Service reservoir (Task 1-60, 1-61, or 1-62).
- Bleed utility hydraulic system (Task 7-334).
- Perform operational check (TM 55-1520-240-T).
- Close right forward work platform or pylon access doors (Task 2-2).

END OF TASK

7-294

INITIAL SETUP

Applicable Configurations:

All

Tools:

Aircraft Mechanic's Tool Kit, NSN 5180-00-323-4692

Materials:

Cloths (E135)
 Paper Tags (E264)
 Gloves (E186)

Personnel Required:

Medium Helicopter Repairer

Equipment Condition:

Battery Disconnected (Task 1-39)
 Electrical Power Off
 Hydraulic Power Off
 Utility Hydraulic System Depressurized (Task 7-135.1)
 Reservoir Drained (Task 1-60.1 or 1-61.1)
 Right Forward Work Platform or Pylon Access Doors
 Open (Task 2-2)

General Safety Instructions:**WARNING**

Hydraulic fluid (E199) is toxic. It can irritate skin and cause burns. Avoid inhaling. Use only with adequate ventilation. Avoid contact with skin, eyes, or clothing. In case of contact, immediately flush skin or eyes with water for at least **15 minutes**. Get medical attention for eyes.

WARNING

Hydraulic fluid ejected under pressure can cause injury to personnel. Hydraulic fluid sprayed into the air is a fire hazard.

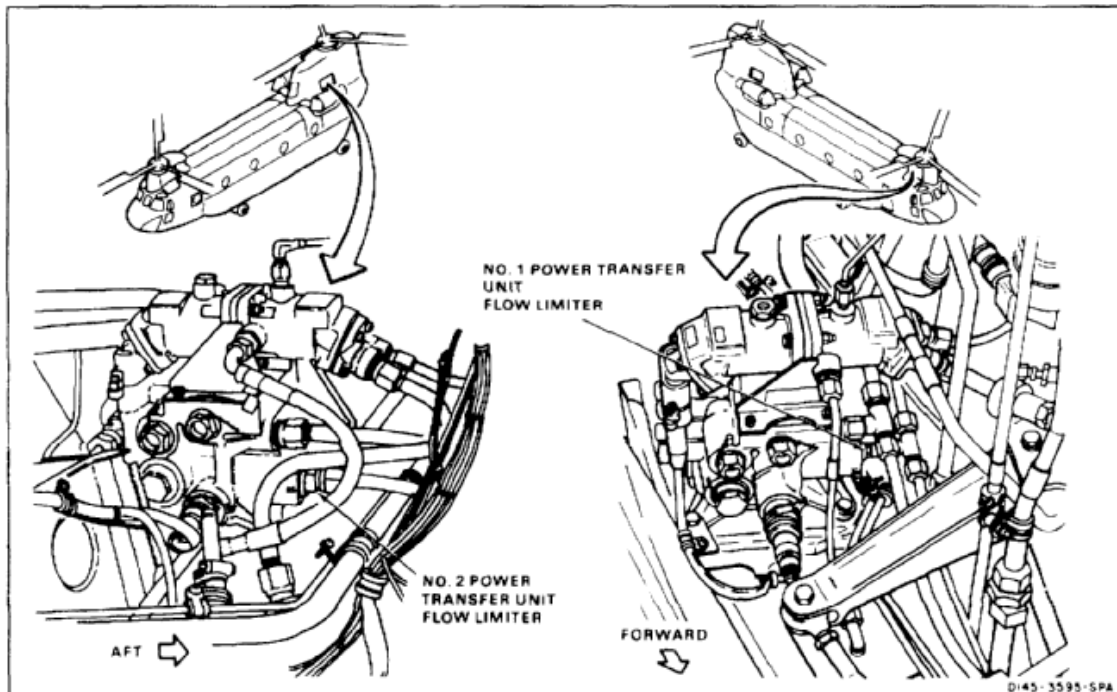

NOTE

Procedure is same to remove flow limiter in No. 1 or No. 2 unit. No. 1 unit is shown here.

1. Tag and disconnect two tubes (1) from tee (2). Use cloths (E135) for spilled fluid. Use gloves (E186).
2. Tag and remove tube (3).
3. Remove tee (2) from limiter (4).
4. Remove lockwire from limiter (4).
5. Remove limiter (4), from housing (5).
6. Remove two retainers (6) and two packings (7) from limiter (4). Use cloths (E135) for spilled fluid.

FOLLOW-ON MAINTENANCE:

None

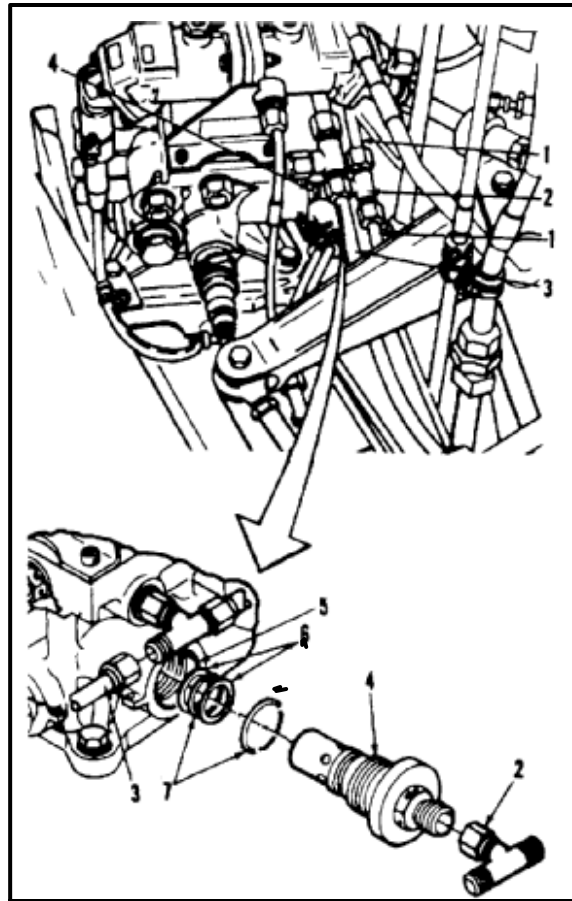

END OF TASK

INITIAL SETUP

Applicable Configurations:

All

Tools:

- Aircraft Mechanic's Tool Kit, NSN 5180-00-323-4692
- Torque Wrench, 700 to 1600 Inch-Pounds
- Hand Oiler

Materials:

- Cloths (E135)
- Hydraulic Fluid (E199)
- Lockwire (E231)

Parts:

- Packings
- Retainers

Personnel Required:

- Medium Helicopter Repairer
- Inspector

References:

TM 55-1520-240-23P

General Safety Instructions:

WARNING

Hydraulic fluid (E199) is toxic. It can irritate skin and cause burns. Avoid inhaling. Use only with adequate ventilation. Avoid contact with skin, eyes, or clothing. In case of contact, immediately flush skin or eyes with water for at least **15 minutes**. Get medical attention for eyes.

WARNING

Hydraulic fluid ejected under pressure can cause injury to personnel. Hydraulic fluid sprayed into the air is a fire hazard.

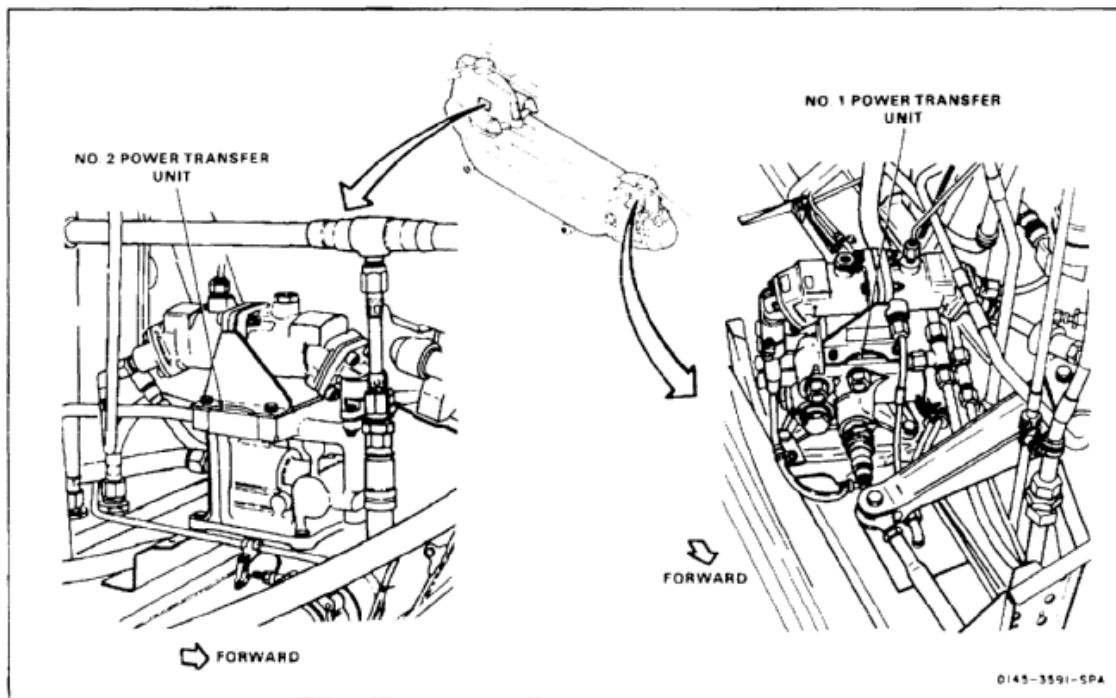

NOTE

Procedure is same to install flow limiter in No. 1 or No. 2 unit. No. 1 unit is shown here.

1. Install packing (1), two retainers (2), and packing (3) on limiter (4).
2. Install limiter (4) in FLOW LIMITER port (5).
3. Lockwire limiter (4) to housing (6). Use lockwire (E231).
4. Connect tube (7) to tee (8) and tube (9). Remove tag.
5. Install tee (10) in limiter (4).

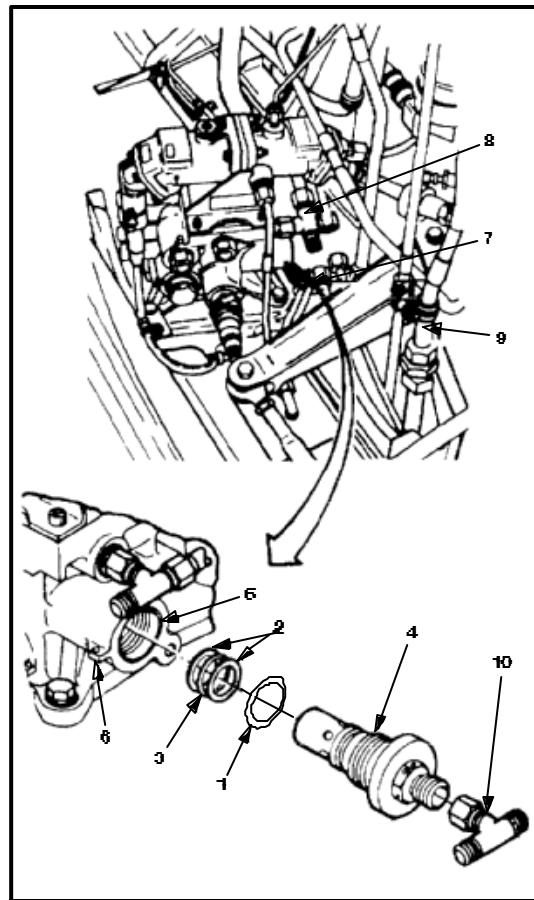

7-67 INSTALL POWER TRANSFER UNIT FLOW LIMITER (Continued)**7-67**

6. Connect two tubes (11) to tee (10).
7. Remove lockwire from plug (12). Remove plug (12) and packing (13) from port (14).
8. Fill motor (15) through port (14) with hydraulic fluid (E199). Use hand oiler. Use cloths (E135) for spilled fluid.
9. Install plug (12) and packing (13) in port (14).
10. Lockwire plug (12) to housing (16). Use lockwire (E231).

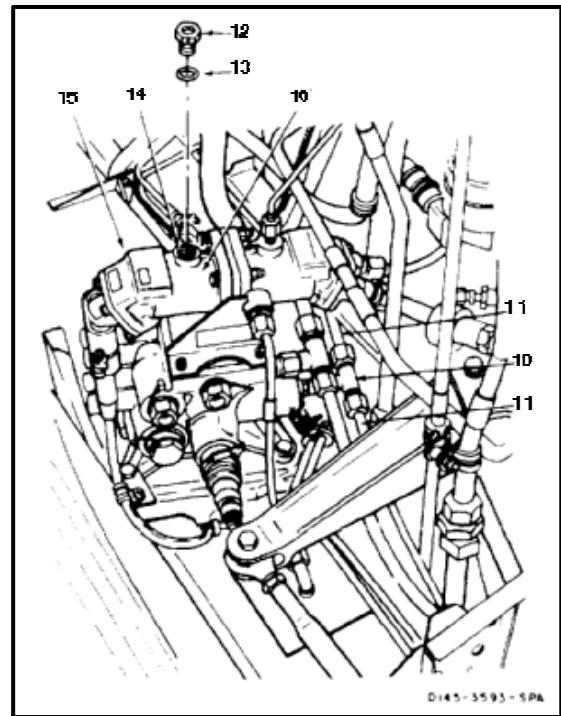
INSPECT**FOLLOW-ON MAINTENANCE:**

- Service reservoir (Task 1-60, 1-61, or 1-62).
- Bleed utility hydraulic system (Task 7-334).
- Perform operational check (TM 55-1520-240-T).
- Close right forward work platform or pylon access doors (Task 2-2),

END OF TASK

INITIAL SETUP

Applicable Configurations:

All

Tools:

Aircraft Mechanic's Tool Kit, NSN 5180-00-323-4692
Container, 2 Quart

Materials:

Cloths (E135)

Personnel Required:

Medium Helicopter Repairer

Equipment Condition:

Off Helicopter Task

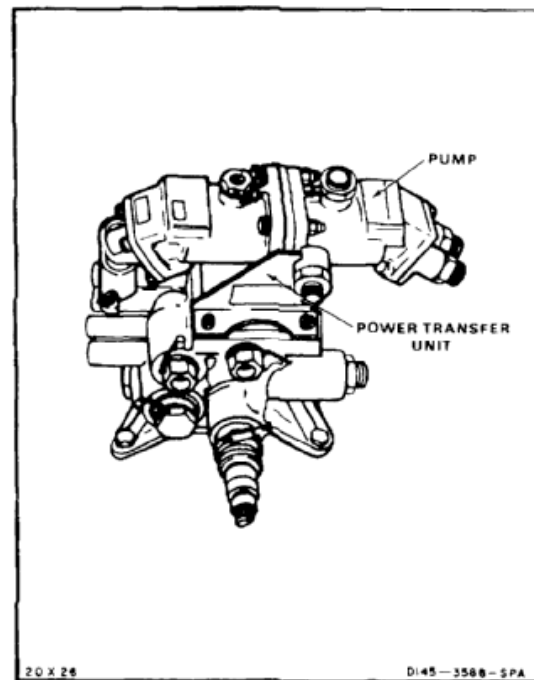
**NOTE**

Procedure is same to remove pump
from No. 1 or No. 2 unit.

1. Remove four bolts (1), washers (2), and nuts (3).

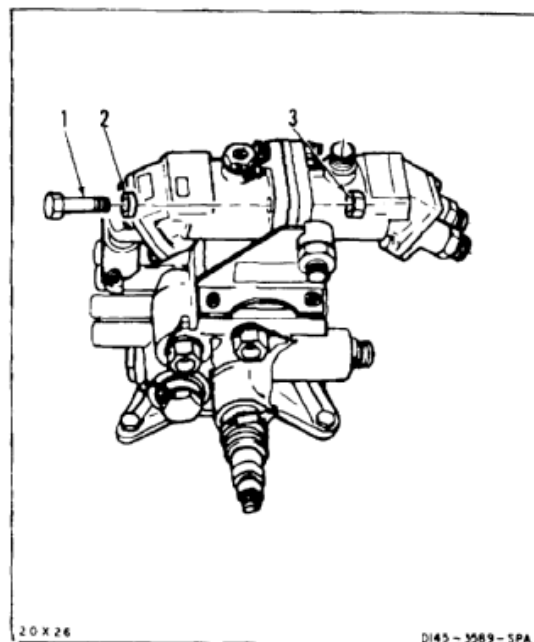

7-68 REMOVE POWER TRANSFER UNIT PUMP (Continued)

7-68

2. Remove pump (4) and gasket (5) from bracket (6).

NOTE

Coupling shaft may come out with pump or remain in motor.

3. Remove shaft (7) from pump (4) or motor (8).
4. Remove nipple (9) and packing (10) from pump (4).

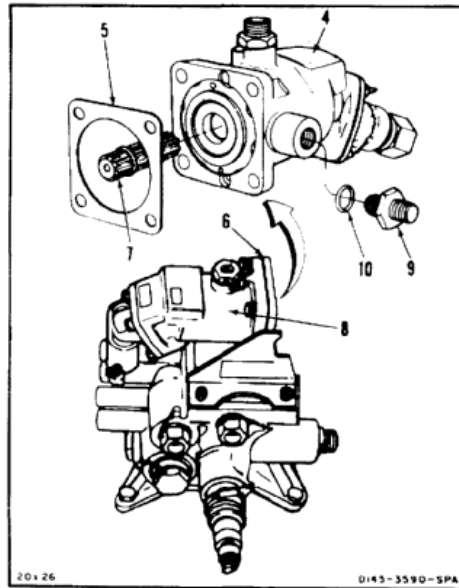
**FOLLOW-ON MAINTENANCE:**

None

END OF TASK

INITIAL SETUP

Applicable Configurations:

All

Tools:

Hydraulic Repairer's Tool Kit, NSN 5180-00-323-4891
Spanner Wrench (APP E-30)
Puller, NSN 5120-00-924-7715
Soft Jawed Vise
Aluminum Rod, 1/4 Inch X 3-3/4 Inches
Retaining Ring Pliers
Adapter 3/8 to 1/2 Inch
Technical Inspection Tool Kit, NSN 5180-00-323-5114

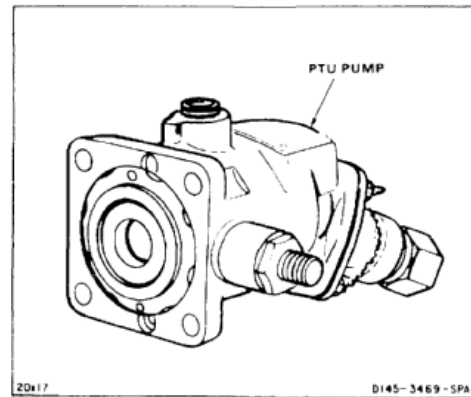
**Materials:**

None

Personnel Required:

Aircraft Pneudraulics Repairer
Inspector

Equipment Condition:

Off Helicopter Task

7-69 REMOVE AND INSPECT POWER TRANSFER UNIT PUMP SHAFT SEAL (590974) (Continued)

NOTE

General inspection criteria (Task 7-1.1) for obvious damage applies unless otherwise stated.

Inspection steps cover parts that are subject to wear.

1. Install pump (1) in vise (2) with flange (3) up.
2. Remove lockscrew (4).
3. Remove nut (5). Use wrench (APP E-30).
4. Install rod (6) in pump (1).



Pump must be positioned with shaft up to keep internal parts from falling out. Keep hand pressure against rod at all times while removing parts. Otherwise, parts can become disassembled, causing damage or loss of parts.

5. Remove retainer (7). Use puller.
- 5.1. Inspect retainer seating surface (7.1) in bore of pump (1). There shall be no nicks or scratches.

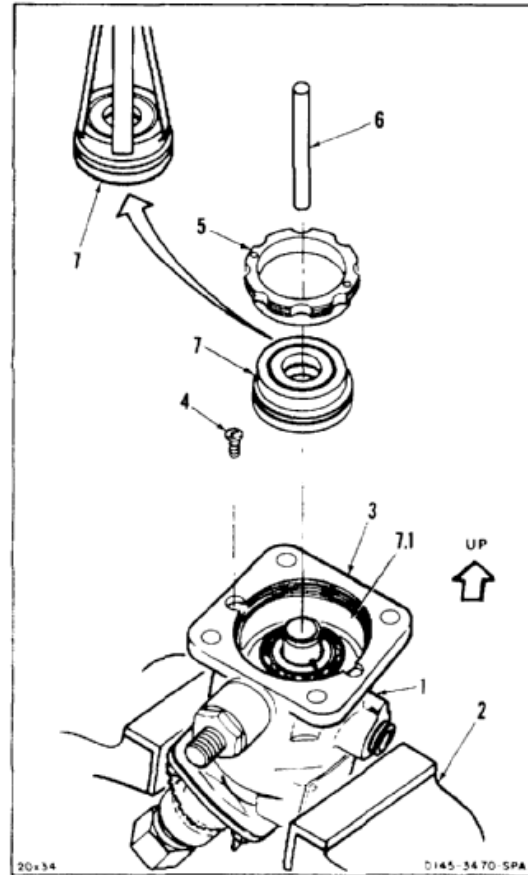

6. Remove seal (8) and packings (9 and 10) from retainer (7).

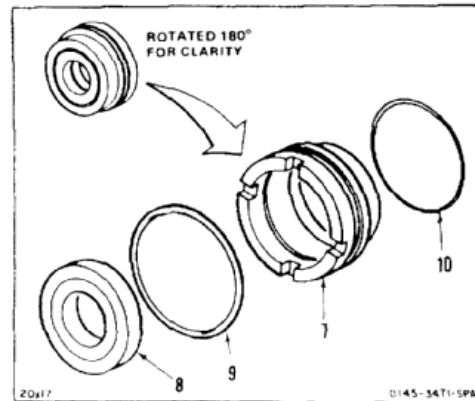

**7-69 REMOVE AND INSPECT POWER TRANSFER UNIT PUMP SHAFT SEAL
(590974) (Continued)**

7-69

7. Remove retainer clip (11), ring (12), and shim (13) from shaft (14). Use retaining ring pliers.

NOTE

Make sure pin does not drop out when removing mating ring.

8. Remove mating ring (15). Use needle nose pliers.
9. Remove pin (16).
10. Remove packing (17) from mating ring (15).
11. Remove rod (6) from shaft (14).
12. Remove pump (1) from vise (2).

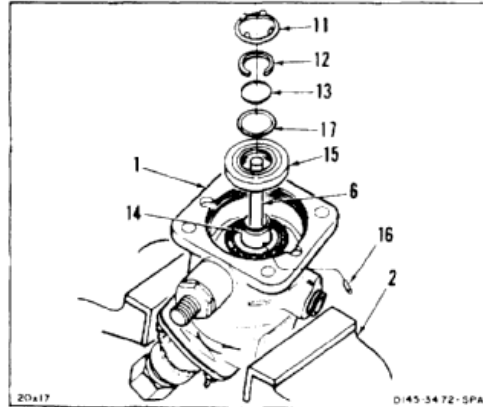
**FOLLOW-ON MAINTENANCE:**

None

END OF TASK

7-304

7-70 INSTALL POWER TRANSFER UNIT PUMP SHAFT SEAL (590974)**7-70****INITIAL SETUP****Applicable Configurations:**

All

Tools:

Hydraulic Repairer's Tool Kit, NSN 5180-00-323-4891
 Feeler Gage
 Soft Jawed Vise
 Spanner Wrench (APP E-30)
 Torque Wrench, 100 to 750 Inch-Pounds
 Wood Dowel, 1-7/8 Inches X 6 Inches

Materials:

Dry Cleaning Solvent (E162)
 Cloth (E120)
 Gloves (E186)
 Grease (E190)

Parts:

Packings
 Seal
 Retainer Clip
 Ring

Personnel Required:

Aircraft Pneudraulics Repairer
 Inspector

References:

TM 55-1520-240-23P

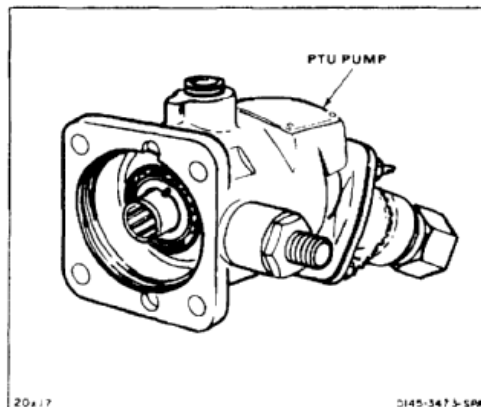
**WARNING**

Dry cleaning solvent (E162) is flammable and toxic. It can irritate skin and cause burns. Use only in well-ventilated area, away from heat and open flame. In case of contact, immediately flush skin or eyes with water for at least **15 minutes**. Get medical attention for eyes.

1. Clean mated parts (1 thru 9). Use dry cleaning solvent (E162). Dry parts with cloth (E120). Use goggles for eyes. Use gloves (E186).

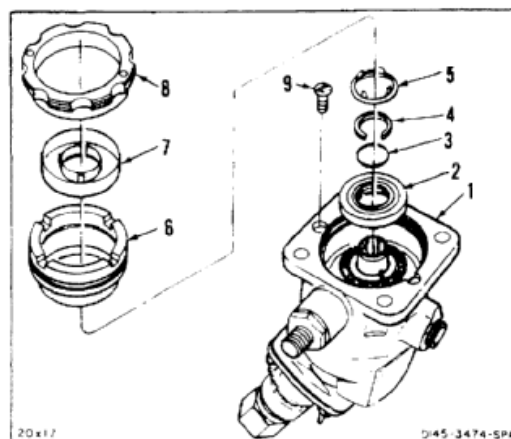
INSPECT

2. Install pump (1) in vise (10).
3. Install packing (11) in mating ring (2).
4. Install pin (12) on shaft (13).
5. Install mating ring (2) on shaft (13). Mating ring shall engage with pin (12).
6. Install shim (3) and new ring (4) on shaft (13).
7. Check end play at mating ring (2). There shall be **0.0005 to 0.003 inch**. If gap is larger, replace shim (3). Use feeler gage.
8. Install new retainer clip (5) on shaft (13).

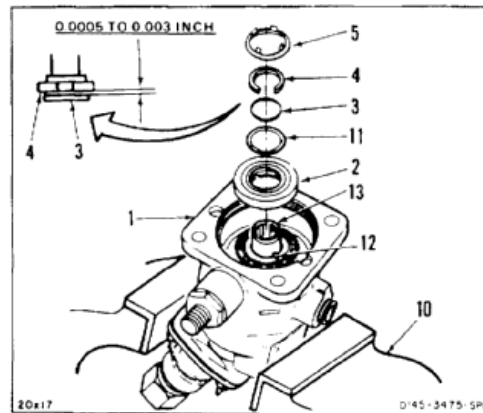

9. Install packing (14) in retainer (6) and packing (15) on retainer.
10. Install subassembly shaft seal (7) in retainer (6). Use dowel.
11. Install retainer (6) in pump (1), carbon side outward.

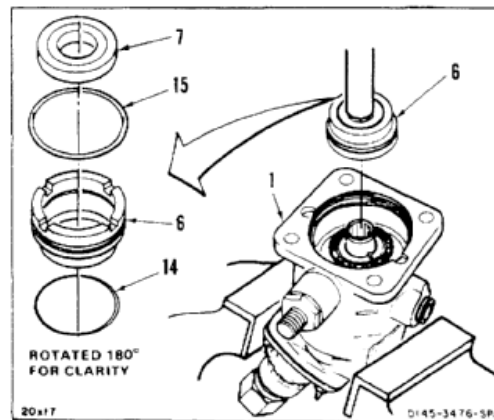

12. Install nut (8) in pump (1). Use wrench (APP E-30). Torque nut to **200 inch-pounds**. Tighten until slot in nut lines up with slot in pump. Do not exceed **300 inch-pounds**.
13. Install lockscrew (9).
14. Fill shaft (13) **1/3** full of grease. Use grease (E190).
15. Remove pump (1) from vise (10).

INSPECT

FOLLOW-ON MAINTENANCE:

Test pump shaft seal (Task 7-71).

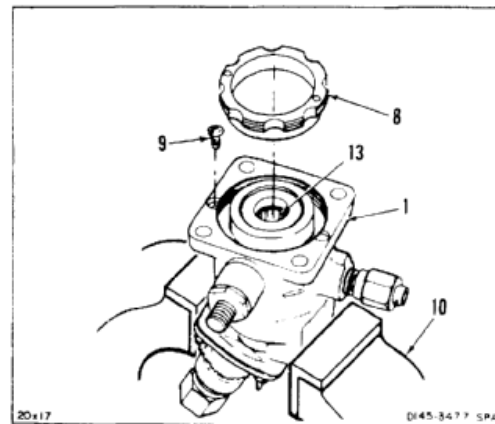

END OF TASK

7-306

INITIAL SETUP

Applicable Configurations:

All

Tools:

Hydraulic Repairer's Tool Kit, NSN 5180-00-323-4891
 Hydraulic Test Stand
 Gage, 0 to 200 psi
 Coupling Shaft (T428318)
 Container, 2 Quart
 Hose, 3/8 Inch, 200 psi

Materials:

Hydraulic Fluid (E199)
 Cloths (E120)

Parts:

Pressure Caps

Personnel Required:

Aircraft Pneudraulics Repairer
 Inspector

Equipment Condition:

Off Helicopter Task
 Test Setup

General Safety Instructions:**WARNING**

Hydraulic fluid (E199) is toxic. It can irritate skin and cause burns. Avoid inhaling. Use only with adequate ventilation. Avoid contact with skin, eyes, or clothing. In case of contact, immediately flush skin or eyes with water for at least **15 minutes**. Get medical attention for eyes.

WARNING

Hydraulic fluid ejected under pressure can cause injury to personnel. Hydraulic fluid sprayed into the air is a fire hazard.

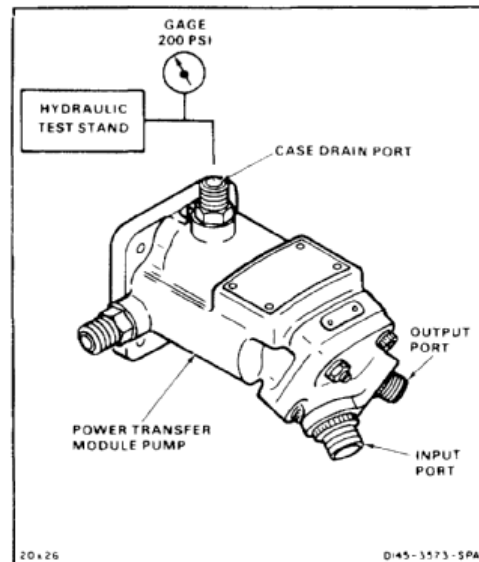

1. Install coupling shaft (T428318) (1) in pump (2).
2. Turn shaft (T428318) (1) by hand. Pump (2) shall turn evenly without binding or noise.
3. Remove coupling shaft (T428318) (1).
4. Install pressure caps (3) on inlet port (4) and outlet port (5) of pump (2).
5. Fill pump (2) through port (6) with hydraulic fluid (E199).
6. Connect pump (2) to test stand (7).

WARNING

Hydraulic fluid ejected under pressure can cause injury to personnel.
Hydraulic fluid sprayed into the air is a fire hazard.

7. Apply **100 psi** to case drain port (6).
8. Check shaft seal (8) for leaks. Shaft seal leaks shall not exceed **5 drops in 10 minutes**. Other leaks shall not be enough to form **1 drop**.
9. Release pressure to **0 psi** at port (6).
10. Disconnect pump (2).
11. Drain hydraulic fluid (E199) from pump (2). Use container and cloths (E120) for spilled fluid.

INSPECT**FOLLOW-ON MAINTENANCE:**

None

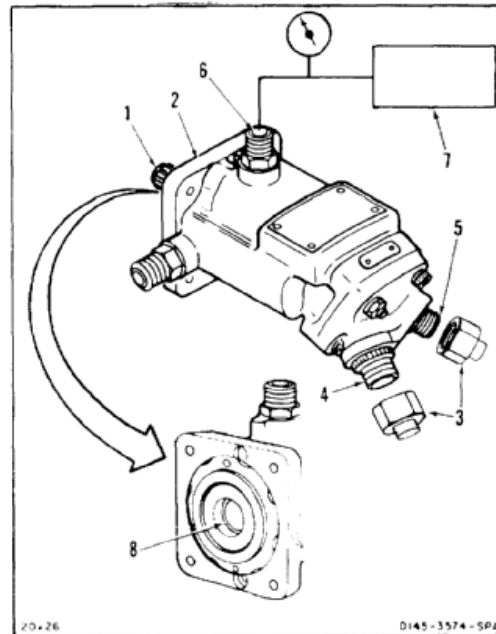

END OF TASK

7-308

7-72 INSTALL NO. 1 OR NO. 2 POWER TRANSFER UNIT PUMP

7-72

INITIAL SETUP**Applicable Configurations:**

All

Tools:

Aircraft Mechanic's Tool Kit, NSN 5180-00-323-4692
Torque Wrench, 30 to 150 Inch-Pounds

Materials:

Grease (E190)

Parts:

Preformed Packings

Personnel Required:

Medium Helicopter Repairer
Inspector

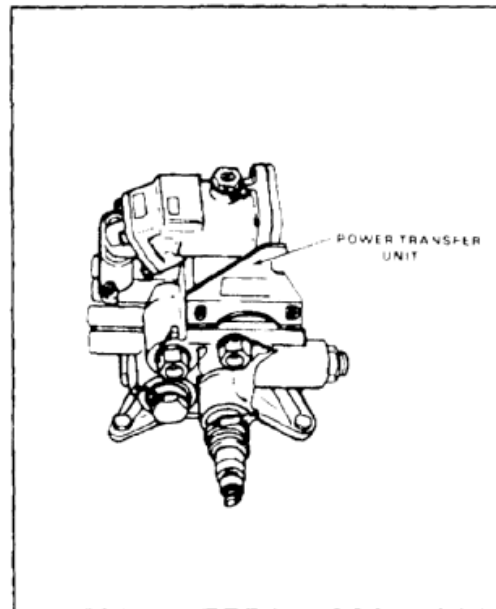
**NOTE**

Procedure is same to install pump on
No. 1 or No. 2 unit.

1. Install nipple (1) and packing (2) in SOL PLT VALVE port (3).
2. Apply grease (E190) to shaft (4). Install shaft in pump (5). Use grease (E190).
3. Install gasket (6) on pump (5).

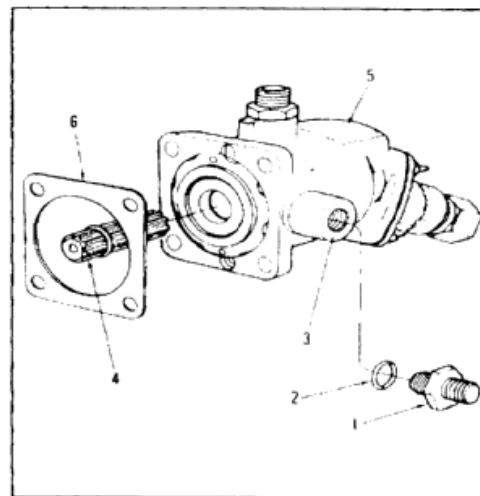

4. Position pump (5) on bracket (7). Install four screws (8), washers (9), and nuts (10). Torque nuts to **85 inch-pounds**.

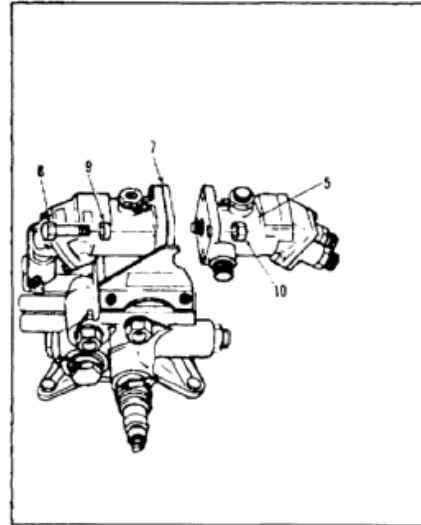
INSPECT**FOLLOW-ON MAINTENANCE:**

None

END OF TASK

7-310

7-73 REMOVE POWER TRANSFER UNIT MOTOR

7-73

INITIAL SETUP**Applicable Configurations:**

All

Tools:

Aircraft Mechanic's Tool Kit, NSN 5180-00-323-4692
 Container, 2 Quart

Materials:

Cloths (E135)
 Lockwire (E231)

Personnel Required:

Medium Helicopter Repairer

Parts:

Preformed Packings
 Retainers

Equipment Condition:

Off Helicopter Task

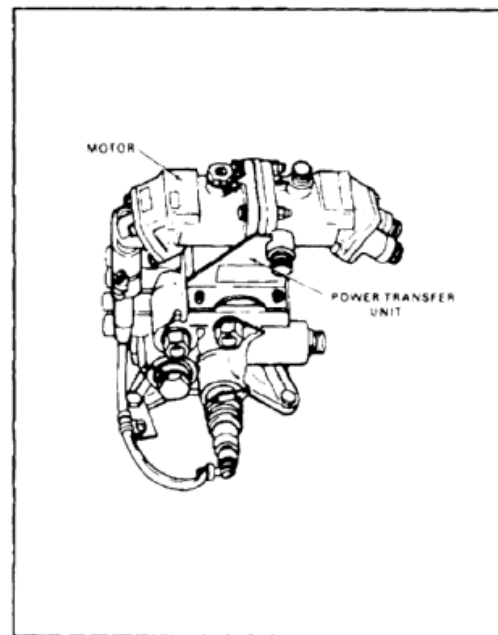
**NOTE**

Procedure is same to remove motor from No. 1 or No. 2 unit.

1. Remove lockwire from valve (1). Remove valve, four retainers (2 and 3), and two packings (4 and 5) from housing (6). Drain fluid from housing (6). Use container and cloths (E135) for spilled fluid.
2. Install two retainers (2) and packing (4) on valve (1).
3. Install two retainers (3) and packing (5) on valve (1).
4. Install valve (1) in CV port (7).
5. Lockwire valve (1). Use lockwire (E231).

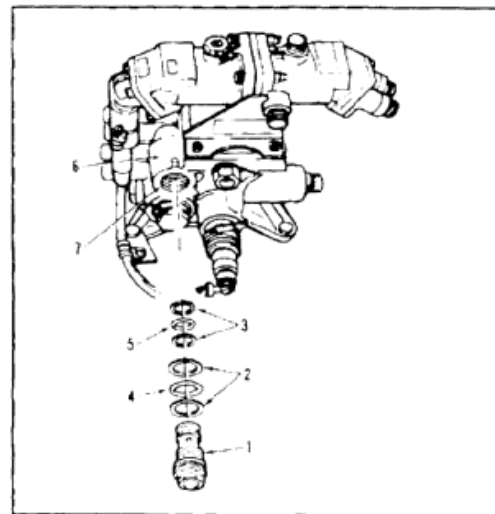

6. Remove four screws (8), washers (9), and nuts (10).
7. Remove pump (11) and gasket (12) from bracket (13).

NOTE

Coupling shaft may come out with pump or remain in motor.

8. Remove shaft (14) from pump (11) or motor (15).

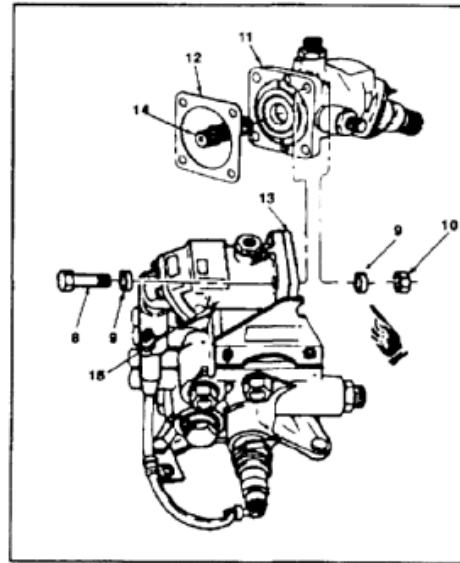

9. Remove two screws (16) and washers (17).
10. Remove motor (15) and gasket (18) from housings (19).

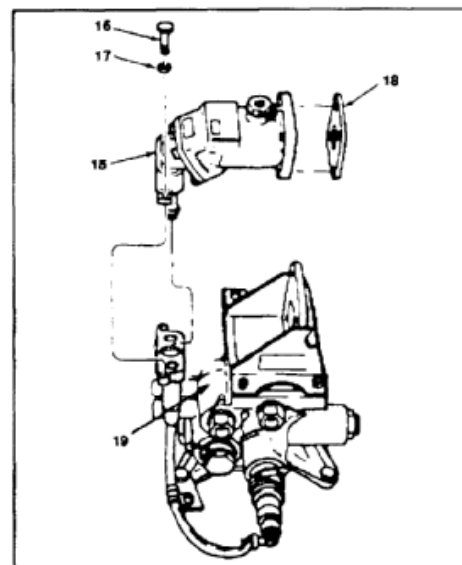

FOLLOW-ON MAINTENANCE:

None

END OF TASK

7-74 REMOVE AND INSPECT POWER TRANSFER UNIT MOTOR SHAFT SEAL (570973) (AVIM)

7-74

INITIAL SETUP**Applicable Configurations:**

All

Tools:

Hydraulic Repairer's Tool Kit, NSN 5180-00-323-4891
 Puller, NSN 5120-00-924-7715
 Spanner Wrench (APP E-30)
 Soft Jawed Vise
 Aluminum Rod, 1/4 Inch X 3-3/4 Inches
 Retaining Ring Pliers
 Technical Inspection Tool Kit, NSN 5180-00-323-5114

Materials:

None

Personnel Required:

Aircraft Pneudraulics Repairer
 Inspector

Equipment Condition:

Off Helicopter Task

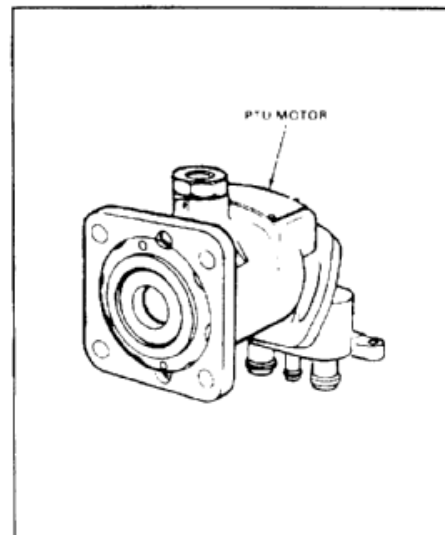
**NOTE**

General inspection criteria (Task 7-1.1) for obvious damage applies unless otherwise stated.

Inspection steps cover parts that are subject to wear.

1. Install motor (1) in vise (2).
2. Remove lockscrew (3).
3. Remove nut (4). Use wrench (APP E-30).
4. Install rod (5) in motor (1).



Motor must be positioned with shaft up to keep internal parts from falling out. Keep hand pressure against rod at all times while removing parts. Otherwise, parts can become disassembled, causing damage or loss of parts.

5. Remove retainer (6). Use puller.
- 5.1. Inspect retainer seating surface (6.1) in bore of motor. There shall be no nicks or scratches.

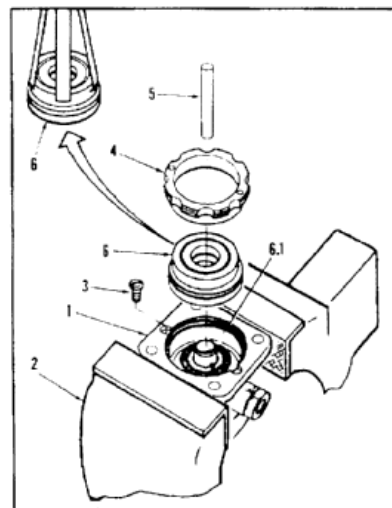

6. Remove seal (7) and packings (8 and 9) from retainer (6).

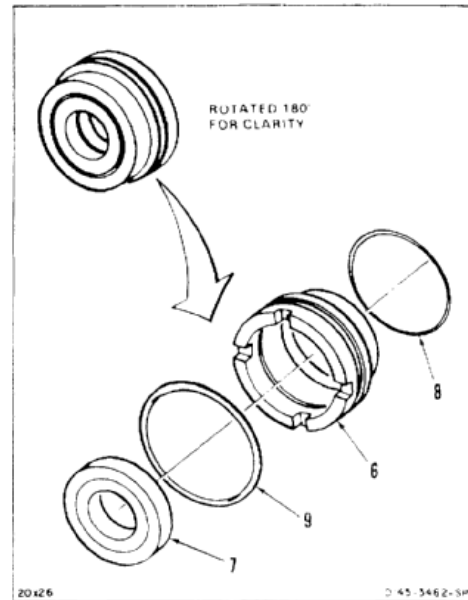

7. Remove retainer clip (10), ring (11), and shim (12) from motor (1). Use retaining ring pliers.

NOTE

Make sure pin does not drop out during removal.

8. Remove mating ring (13). Use needle nose pliers.
9. Remove pin (14). Use needle nose pliers.
10. Remove packing (15) from mating ring (13).
11. Remove rod (5).
12. Remove motor (1) from vise (2).

FOLLOW-ON MAINTENANCE:

None

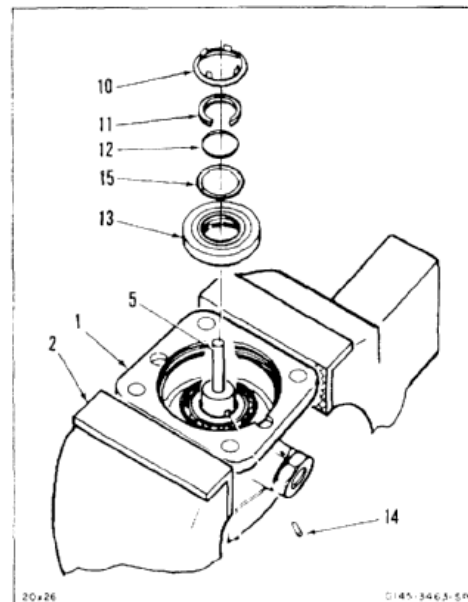

END OF TASK

INITIAL SETUP

Applicable Configurations:

All

Tools:

Hydraulic Repairer's Tool Kit, NSN 5180-00-323-4891
 Feeler Gage
 Spanner Wrench (APP E-30)
 Torque Wrench, 100 to 750 Inch-Pounds
 Soft Jawed Vise
 Wood Dowel, 7/8 Inch X 6 Inches
 Retaining Ring Pliers

Materials:

Dry Cleaning Solvent (E162)
 Gloves (E186)
 Cloth (E120)

Parts:

Packings
 Seal
 Retainer Clip Ring

Personnel Required:

Aircraft Pneudraulics Repairer
 Inspector

References:

TM 55-1520-240-23P

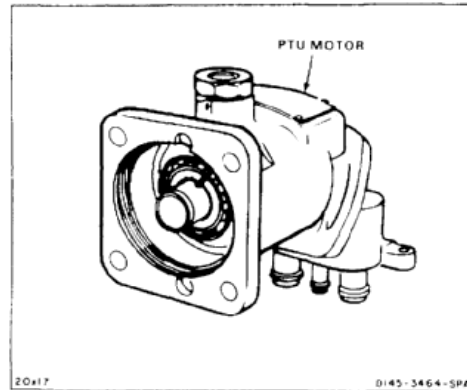
**WARNING**

Dry cleaning solvent (E162) is flammable and toxic. It can irritate skin and cause burns. Use only in well-ventilated area, away from heat and open flame. In case of contact, immediately flush skin or eyes with water for at least **15 minutes**. Get medical attention for eyes.

1. Clean metal parts (1 thru 9). Use dry cleaning solvent (E162). Dry parts with cloth (E120). Use goggles for eyes. Use gloves (E186).

INSPECT

2. Install motor (1) in vise (10).

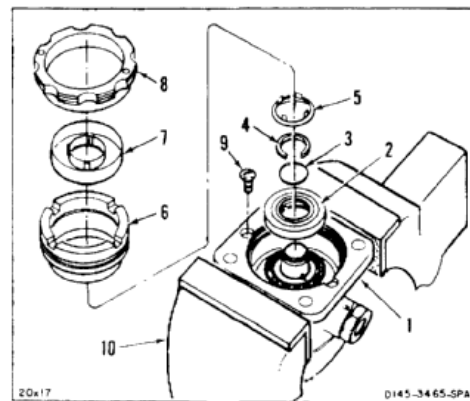

3. Install packing (11) in mating ring (2).
4. Install pin (12) in shaft (13). Use needle nose pliers.
5. Install mating ring (2) on shaft (13). Mating ring must engage with pin (12).
6. Install shim (3) and ring (4) on shaft (13).
7. Check end play of mating ring (2). There shall be **0.0015 to 0.003 inch** gap. If gap is larger, replace shim (3). Use feeler gage.
8. Install retainer clip (5) on shaft (13).

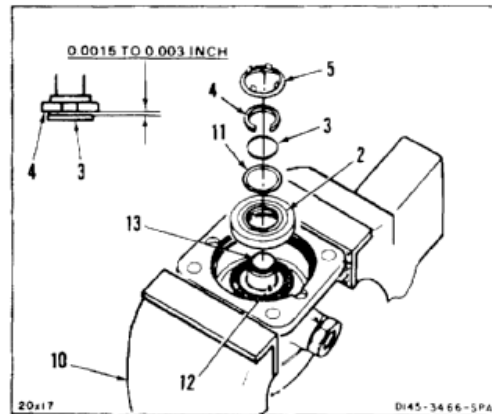

9. Install two packings (14 and 15) on retainer (6).
10. Install subassembly shaft seal (7) in retainer (6). Use dowel.
11. Install retainer (6) in motor (1), carbon side outward.

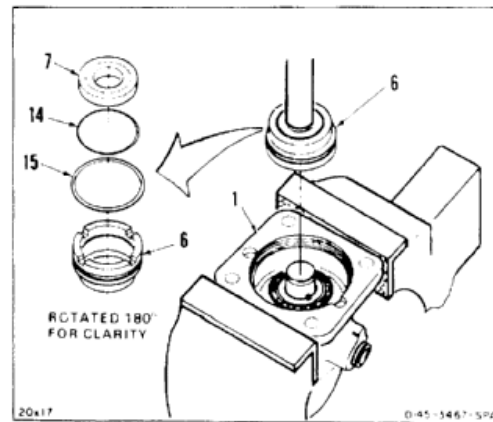

12. Install nut (8) in motor (1). Use wrench (APP E-30). Torque nut to **200 inch-pounds**. Tighten until slot in nut aligns with slot in motor. Do not exceed **300 inch-pounds**.
13. Install lockscrew (9).
14. Remove motor (1) from vise (10).

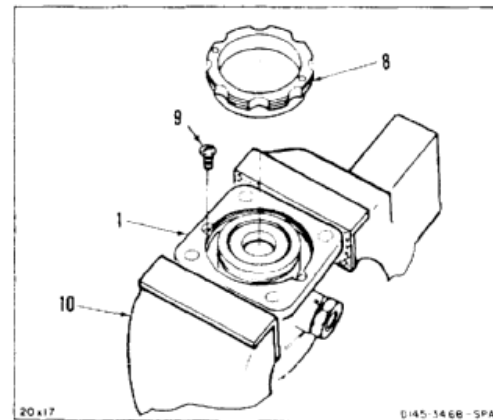

INSPECT

FOLLOW-ON MAINTENANCE:

Test motor shaft seal (Task 7-76).

END OF TASK

INITIAL SETUP

Applicable Configurations:

All

Tools:

Hydraulic Repairer's Tool Kit, NSN 5180-00-323-4891
 Hydraulic Test Stand
 Stop Watch
 Coupling Shaft (428318)
 Gage, 0 to 200 psi
 Container, 2 Quart
 Test Block (145G0056)

Materials:

Hydraulic Fluid (E199)
 Cloths (E120)

Parts:

Pressure Caps

Personnel Required:

Aircraft Pnedraulics Repairer
 Inspector

Equipment Condition:

Off Helicopter Task
 Test Setup

General Safety Instructions:**WARNING**

Hydraulic fluid (E199) is toxic. It can irritate skin and cause burns. Avoid inhaling. Use only with adequate ventilation. Avoid contact with skin, eyes, or clothing. In case of contact, immediately flush skin or eyes with water for at least **15 minutes**. Get medical attention for eyes.

WARNING

Hydraulic fluid ejected under pressure can cause injury to personnel. Hydraulic fluid sprayed into the air is a fire hazard.

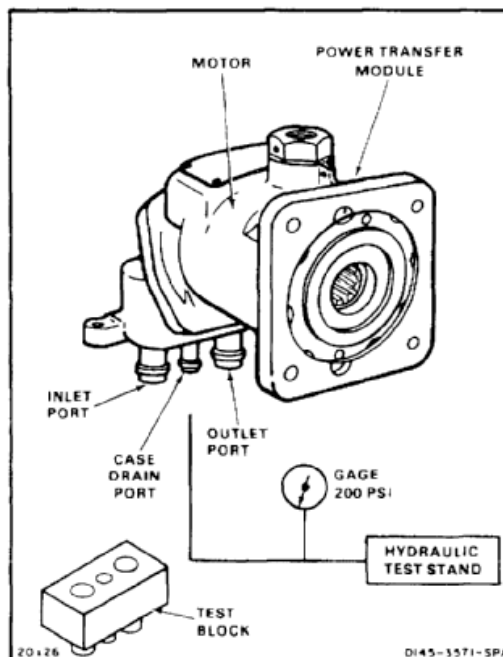

1. Install coupling shaft (428318) (1) in motor (2).
2. Turn shaft (428318) (1) by hand. Shaft shall turn evenly without binding or noise.
3. Remove coupling shaft (428318) (1).
4. Install test block (3) on motor (2).
5. Install pressure caps (4) on inlet port (5) and outlet port (6).
6. Fill motor (2) through port (7) with hydraulic fluid (E199).
7. Connect case drain port (7) to test stand (8).

WARNING

Hydraulic fluid ejected under pressure can cause injury to personnel. Hydraulic fluid sprayed into the air is a fire hazard.

8. Apply **100 psi** to port (7).
9. Check shaft seal (9) for leaks. Shaft seal leaks shall not exceed **5 drops in 10 minutes**. Other leaks shall not be enough to form **1 drop**.
10. Release pressure to **0 psi** at port (7).
11. Disconnect motor (2) from test stand (8).
12. Drain hydraulic fluid (E199) from motor (2). Use container and cloths (E120) for spilled fluid.
13. Remove block (3) from motor (2).

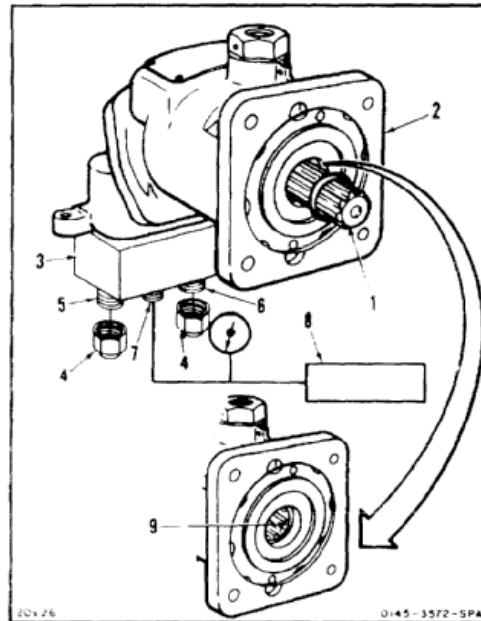

INSPECT

FOLLOW-ON MAINTENANCE:

None

END OF TASK

7-318

7-77 INSTALL POWER TRANSFER UNIT MOTOR

7-77

INITIAL SETUP**Applicable Configurations:**

All

Tools:

Aircraft Mechanic's Tool Kit, NSN 5180-00-323-4692
 Container, 2 Quart
 Torque Wrench, 30 to 150 Inch-Pounds

Materials:

Cloths (E135)
 Hydraulic Fluid (E199)
 Grease (E190)
 Lockwire (E231)

Parts:

Gaskets
 Preformed Packing

Personnel Required:

Medium Helicopter Repairer
 Inspector

References:

TM 55-1520-240-23P

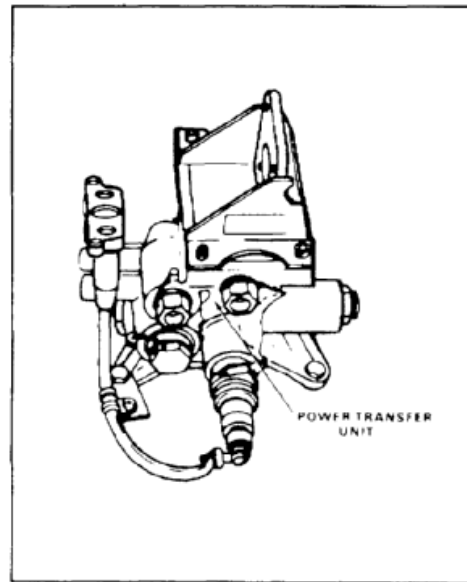
**NOTE**

Procedure is same to install motor on
 No. 1 or No. 2 unit.

1. Position motor (1) and gasket (2) on housing (3).
 Install two screws (4) and washers (5).

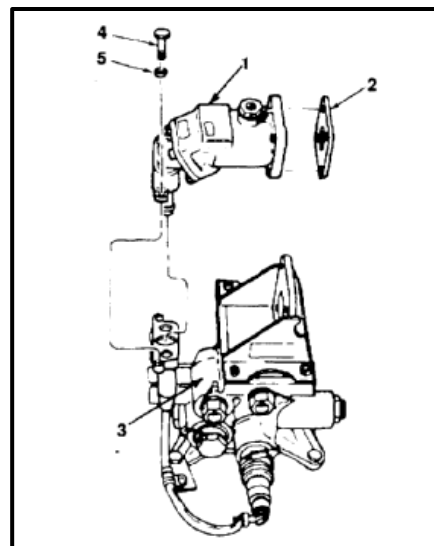

2. Apply grease (E190) on shaft (8). Install shaft in pump (9).
3. Position pump (9) and gasket (10) on motor (1) and bracket (11). Install four screws (12), washers (13), and nuts (14). Torque nuts to **85 inch-pounds**.

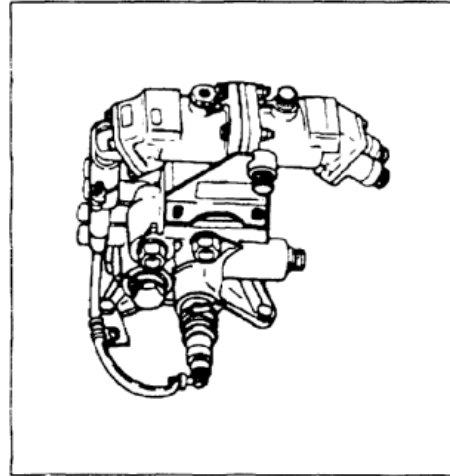
INSPECT**FOLLOW-ON MAINTENANCE:**

None

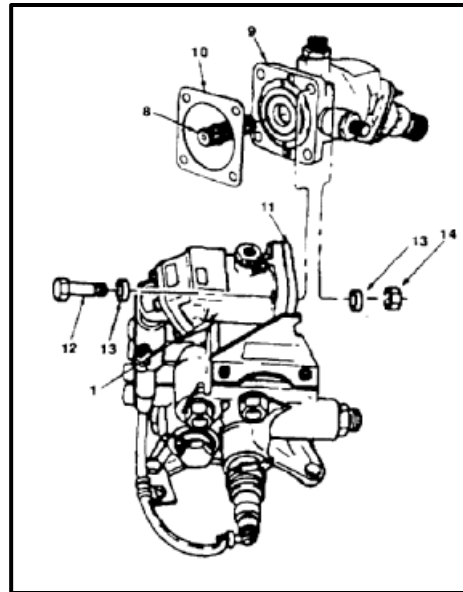

END OF TASK

7-320

INITIAL SETUP

General Safety Instructions:

Applicable Configurations:

All

Tools:

Aircraft Mechanic's Tool Kit, NSN 5180-00-323-4692
 Container, 2 Quart

Materials:

Cloths (E135)
 Paper Tags (E264)
 Gloves (E186)

Personnel Required:

Medium Helicopter Repairer

Equipment Condition:

Battery Disconnected (Task 1-39)
 Electrical Power Off
 Hydraulic Power Off
 Controls Closet Acoustic Blanket Removed (Task 2-107)
 Controls Closet Panel Open (Task 2-2)

WARNING

Hydraulic fluid (E199) is toxic. It can irritate skin and cause burns. Avoid inhaling. Use only with adequate ventilation. Avoid contact with skin, eyes, or clothing. In case of contact, immediately flush skin or eyes with water for at least **15 minutes**. Get medical attention for eyes.

WARNING

Hydraulic fluid ejected under pressure can cause injury to personnel. Hydraulic fluid sprayed into the air is a fire hazard.

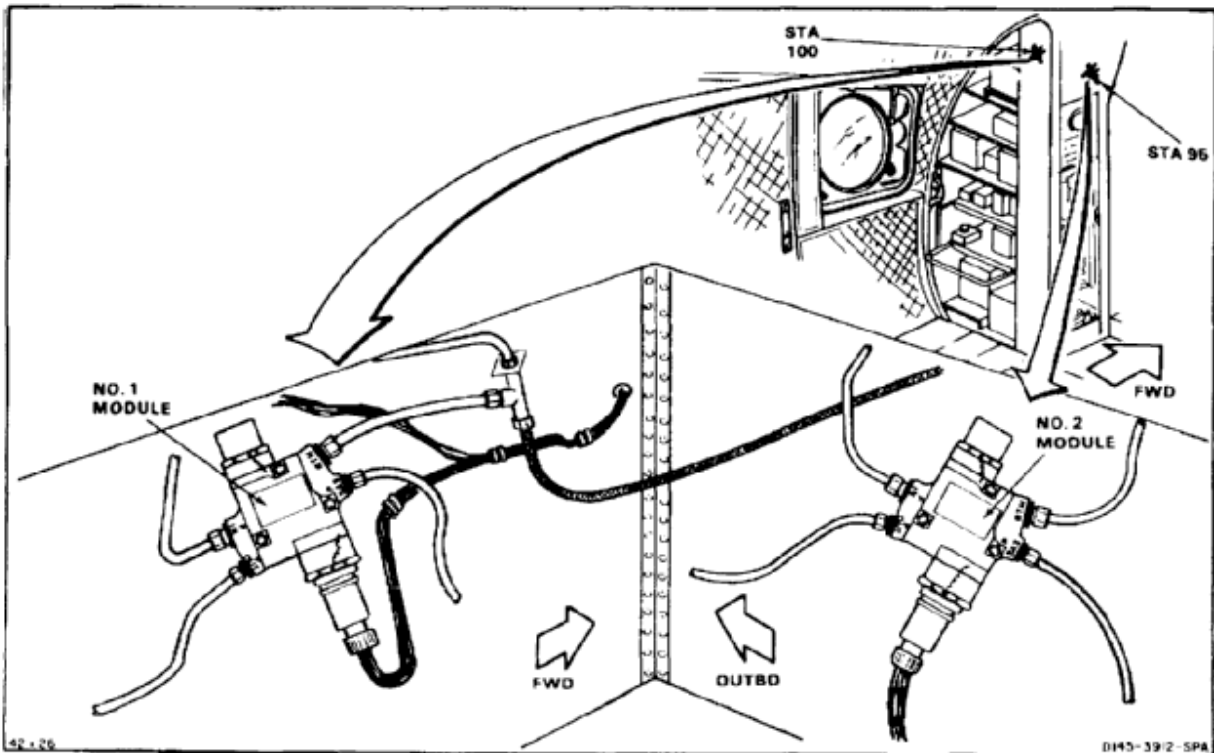

NOTE

Procedure is same to remove No. 1 or No. 2 module. Removal of No. 2 control module is shown here.

1. Disconnect connector (1) from module (2).
2. Tag and disconnect four tubes (3) from module (2). Use container and cloths (E135) for spilled fluid. Use gloves (E186).
3. Remove three bolts (4) and washers (5).
4. Remove module (2).

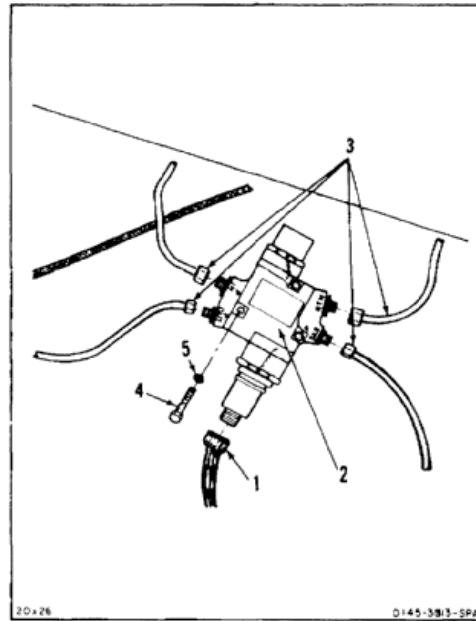
**FOLLOW-ON MAINTENANCE:**

None

END OF TASK

7-322

INITIAL SETUP

Applicable Configurations:

All

Tools:

Aircraft Mechanic's Tool Kit, NSN 5180-00-323-4692

Materials:

None

Personnel Required:

Medium Helicopter Repairer
Inspector

References:

TM 55-1520-240-23P

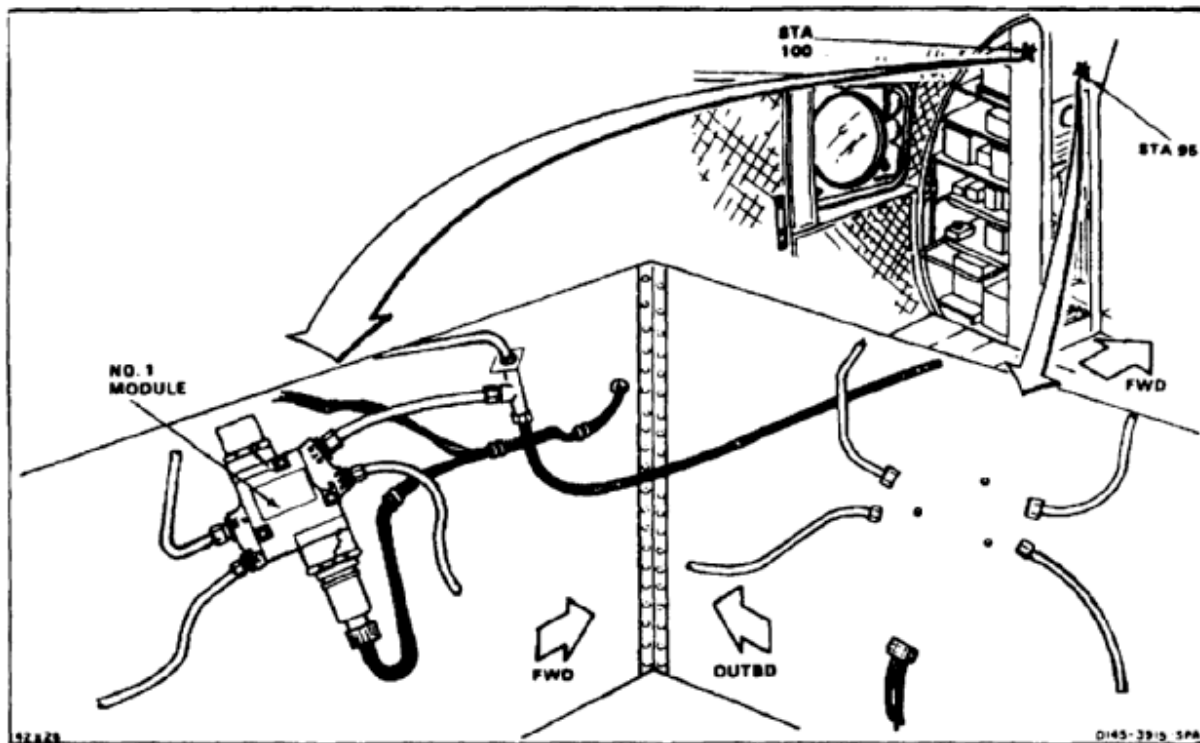

NOTE

Procedure is same to install No. 1 or No. 2 module. Installation of No. 2 control module is shown here.

1. Position module (1) on structure (2). Install three bolts (3) and washers (4).
2. Connect tube (5) to P IN port (6). Remove tag.
3. Connect tube (7) to P OUT port (8). Remove tag.
4. Connect tube (9) to R TN port (10). Remove tag.
5. Connect tube (11) to P AFCS port (12). Remove tag.
6. Connect connector (13) to valve (14).

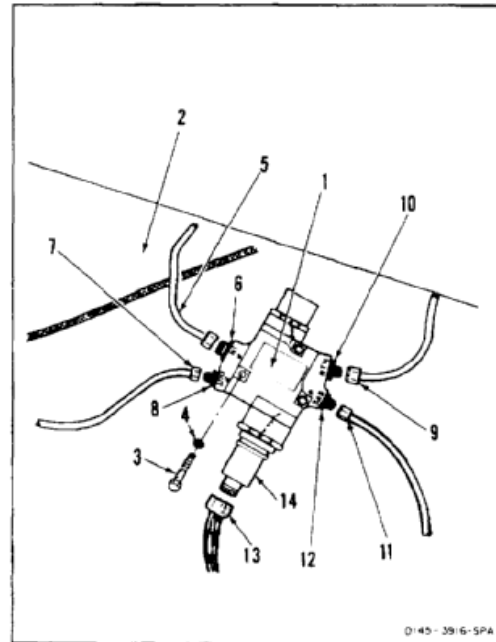
INSPECT**FOLLOW-ON MAINTENANCE:**

- Service flight control reservoir (Task 1-60, 1-61, or 1-62).
- Perform operational check (TM 55-1520-240-T).
- Close controls closet panel (Task 2-2).
- Install controls closet acoustic blanket (Task 2-108).

END OF TASK

7-80 REMOVE NO. 1 OR NO. 2 FLIGHT CONTROL LOWER CONTROLS MODULE SOLENOID VALVE

7-80

INITIAL SETUP

Applicable Configurations:

All

Tools:

Aircraft Mechanic's Tool Kit, NSN 5180-00-323-4692
 Container, 2 Quart

Materials:

Cloths (E135)
 Gloves (E186)

Personnel Required:

Medium Helicopter Repairer

Equipment Condition:

Battery Disconnected (Task 1-39)
 Electrical Power Off
 Hydraulic Power Off
 Controls Closet Acoustic Blanket Removed (Task 2-107)
 Controls Closet Panel Open (Task 2-2)

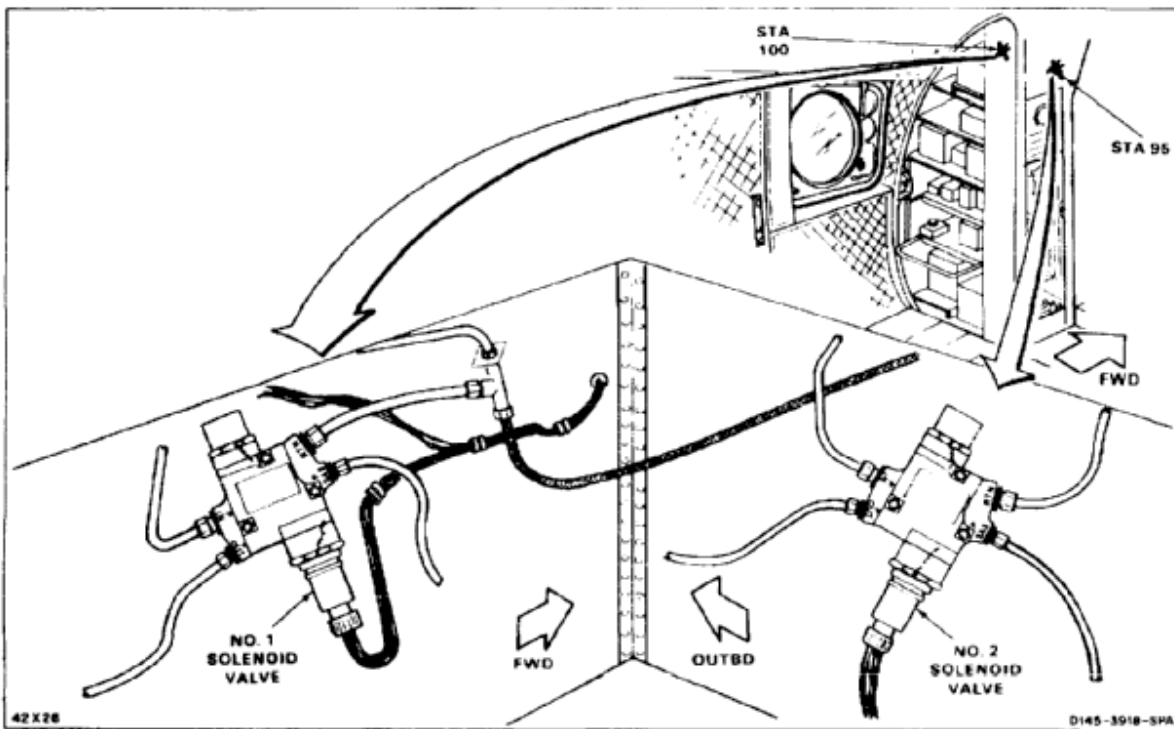

NOTE

Procedure is same to remove No. 1 or No. 2 module solenoid valve. Removal of No. 2 module solenoid valve is shown here.

1. Disconnect connector (1) from valve (2).
2. Remove lockwire from valve (2).
3. Remove valve (2), six retainers (3), and three packings (4) from module (5). Use container and cloths (E135) for spilled fluid. Use gloves (E186).

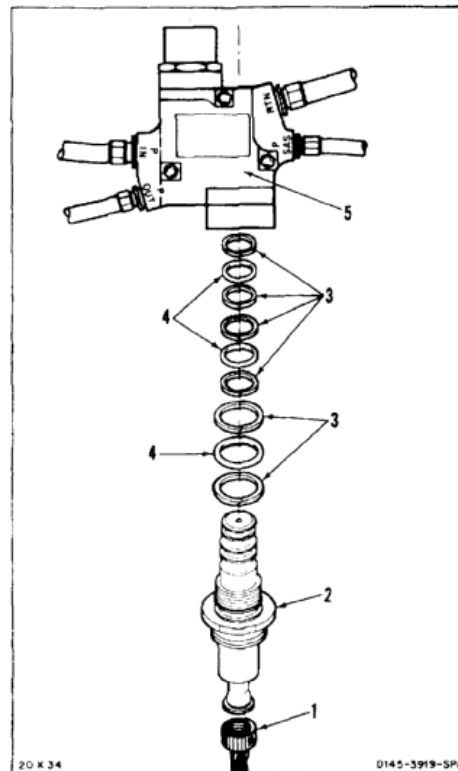
**FOLLOW-ON MAINTENANCE:**

None

END OF TASK

7-326

7-81 INSTALL NO. 1 OR NO. 2 FLIGHT CONTROL LOWER CONTROLS MODULE SOLENOID VALVE

7-81

INITIAL SETUP

Applicable Configurations:

All

Tools:

Aircraft Mechanic's Tool Kit, NSN 5180-00-323-4692
Torque Wrench, 30 to 150 Inch-Pounds

Materials:

Lockwire (E231)

Parts:

Preformed Packings
Retainers

Personnel Required:

Medium Helicopter Repairer
Inspector

References:

TM 55-1520-240-23P

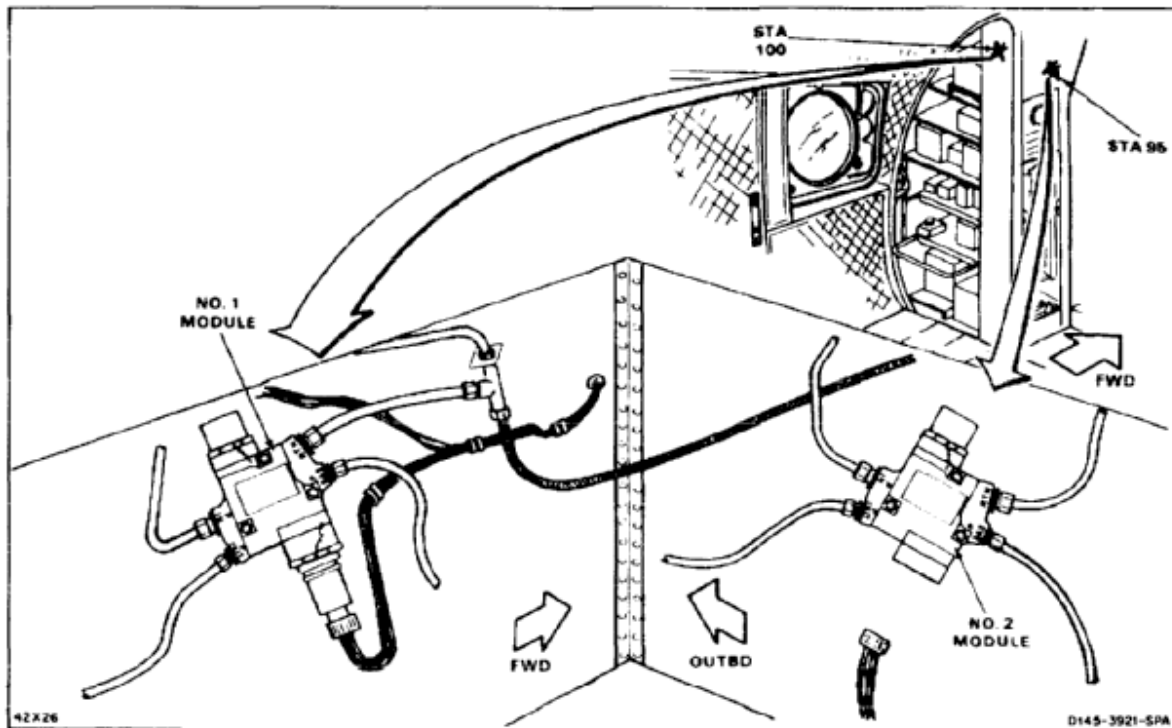

NOTE

Procedure is same to install No. 1 or No. 2 module solenoid valve. Installation of No. 2 module solenoid valve is shown here.

1. Install two retainers (1), packing (2), four retainers (3), and two packings (4) on valve (5).
2. Install valve (5) in port (6).
3. Torque valve (5) to **130 inch-pounds**.
4. Connect connector (7) to valve (5).
5. Lockwire valve (5) to module (8). Use lockwire (E231).

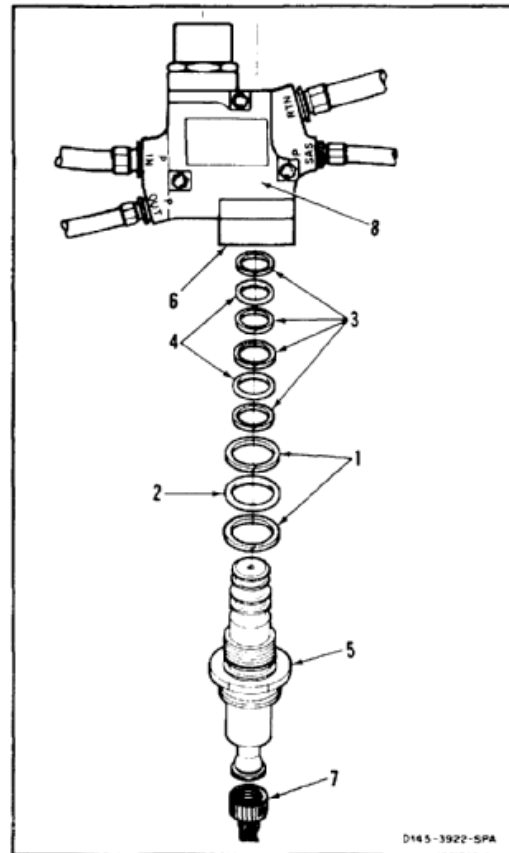
**FOLLOW-ON MAINTENANCE:**

- Service flight control reservoir (Task 1-60, 1-61, or 1-62).
- Perform operational check (TM 55-1520-240-T).
- Close controls closet door (Task 2-2).
- Install controls closet acoustic blanket (Task 2-108).

END OF TASK

7-328

7-82 REMOVE NO. 1 OR NO. 2 FLIGHT CONTROL LOWER CONTROLS MODULE PRESSURE REDUCER VALVE

7-82

INITIAL SETUP

Applicable Configurations:

All

Tools:

Aircraft Mechanic's Tool Kit, NSN 5180-00-323-4692
 Socket, 1-1/4 Inch

Materials:

Cloths (E135)

Personnel Required:

Medium Helicopter Repairer

Equipment Condition:

Battery Disconnected (Task 1-39)
 Electrical Power Off
 Hydraulic Power Off
 Controls Closet Acoustic Blanket Removed (Task 2-107)
 Controls Closet Panel Open (Task 2-2)

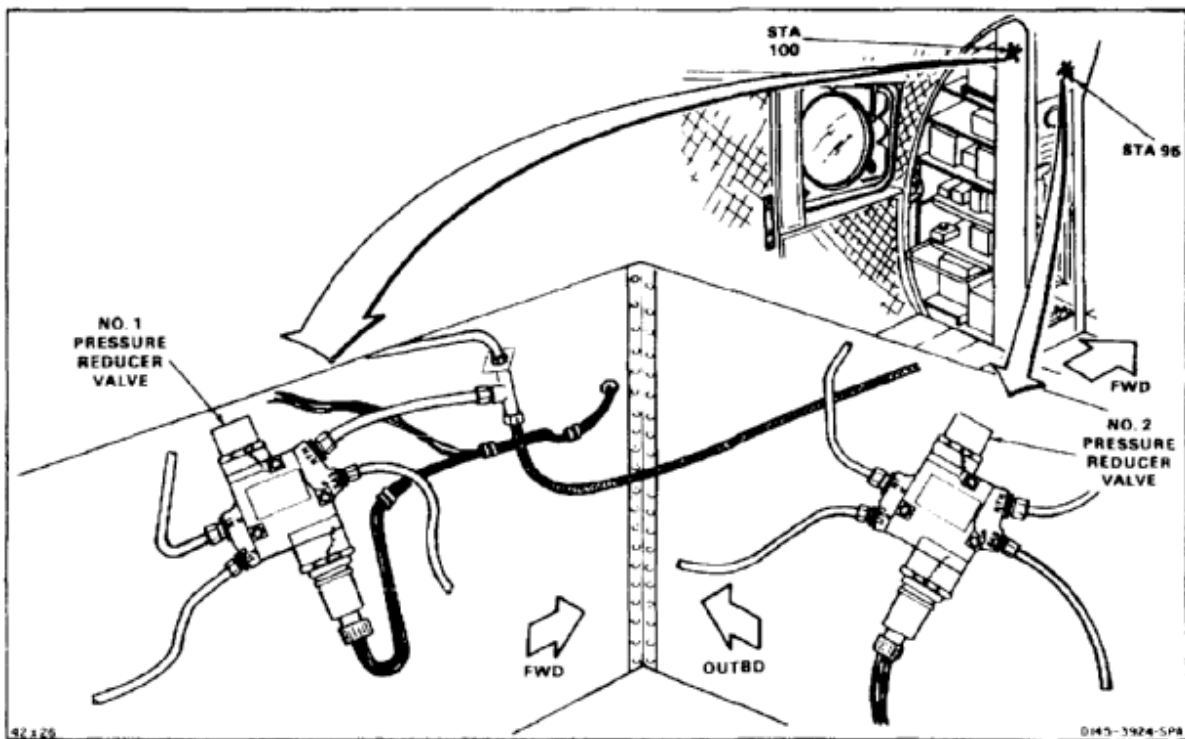

NOTE

Procedure is same to remove No. 1 or No. 2 module pressure reducer valve. Removal of No. 2 module pressure reducer valve is shown here.

1. Remove lockwire from valve (1).
2. Remove valve (1), four retainers (2), and three packings (3) from module (4). Use container and cloths (E135) for spilled fluid.

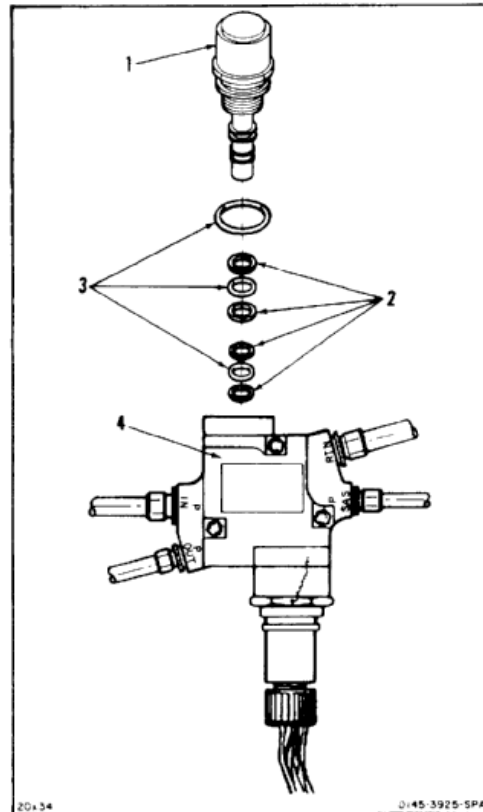
**FOLLOW-ON MAINTENANCE:**

None

END OF TASK

7-330

7-83 INSTALL NO. 1 OR NO. 2 FLIGHT CONTROL LOWER CONTROLS MODULE PRESSURE REDUCER VALVE

7-83

INITIAL SETUP

Applicable Configurations:

All

Tools:

Aircraft Mechanic's Tool Kit, NSN 5180-00-323-4692
Torque Wrench, 30 to 150 Inch-Pounds

Materials:

Lockwire (E231)

Parts:

Preformed Packings
Retainers

Personnel Required:

Medium Helicopter Repairer
Inspector

References:

TM 55-1520-240-23P

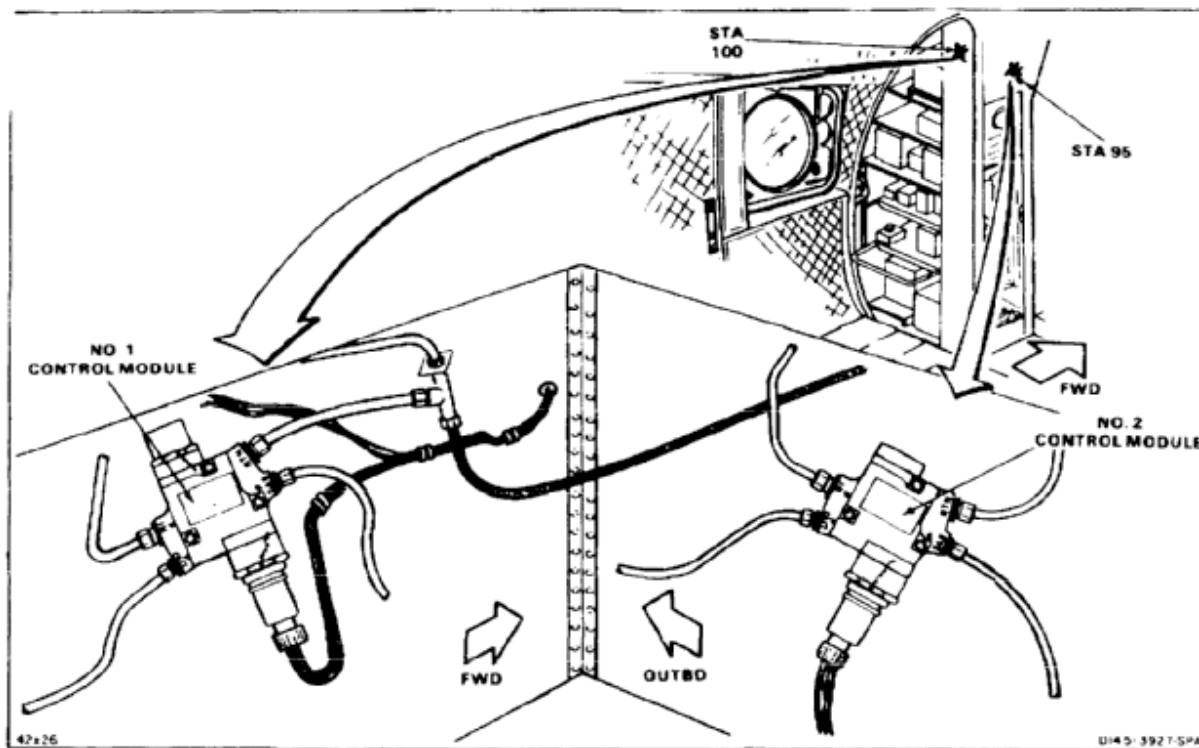

NOTE

Procedure is same to install No. 1 or No. 2 module pressure reducer valve. No. 2 module pressure reducer valve is shown here.

1. Install packing (1), four retainers (2), and two packings (3) on valve (4).
2. Install valve (4) in port (5).
3. Torque valve (4) to **130 inch-pounds**.
4. Lockwire valve (4) to module (6). Use lockwire (E231).

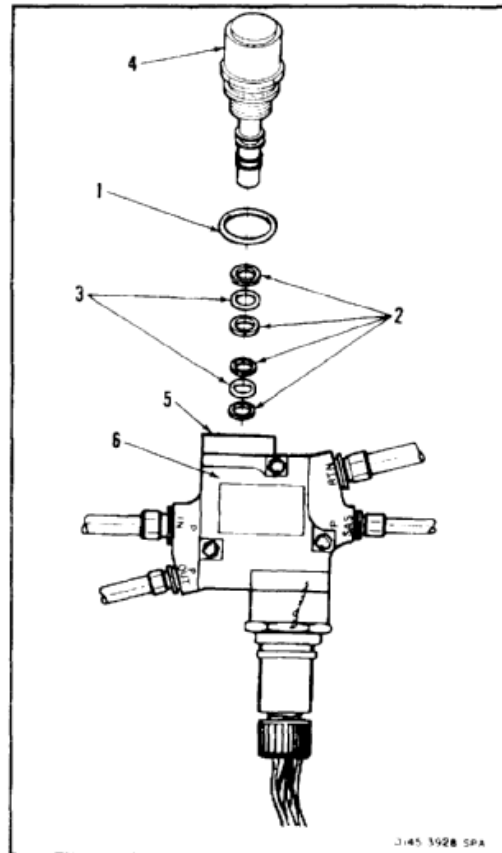
INSPECT**FOLLOW-ON MAINTENANCE:**

- Service flight control reservoir (Task 1-60, 1-61, or 1-62).
- Perform operational check (TM 55-1520-240-T).
- Close controls closet panel (Task 2-2).
- Install controls closet acoustic blanket (Task 2-108).

END OF TASK

INITIAL SETUP

Applicable Configurations:

All

Tools:

Dial Indicator (2), NSN 5210-00-277-8840

Materials:

None

Personnel Required:

Inspector

Equipment Condition:

Off Helicopter Task

References:

Task 11-8
Task 11-9

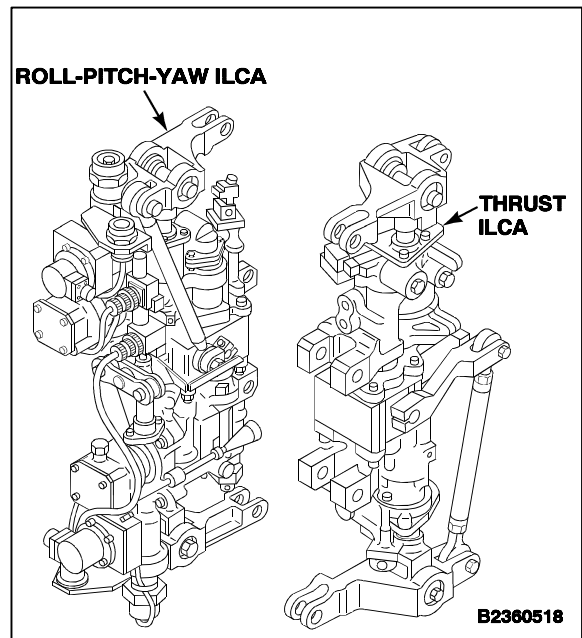

NOTE

Procedure is same to inspect pitch, roll, or yaw ILCAs.

Inspection of thrust ILCA is as noted.

If jam nuts on input valve links are found loose, inspect the rod end ball bearing installation to ensure that nut retaining key and lockwire are installed. If key and lockwire are installed, loose nuts are acceptable. If key and lockwire are not installed, replace the ILCA. Do not attempt to retorquer the jam nuts.

1. Perform a general visual inspection for loose or missing fasteners, mounting bolts, safety wire, and cotter pins.
2. Check for cracked bolt collars (1). There shall be no cracks.
3. Check for looseness of bolts and bolt collars (1). Turn collars by hand. If collar turns, relative to clevis assembly, or independent of bolt, replace ILCA.
4. Check for corrosion between collar (1) and bolt (2), collar and bearing (3) or collar and linkage (3.1). There shall be no corrosion.

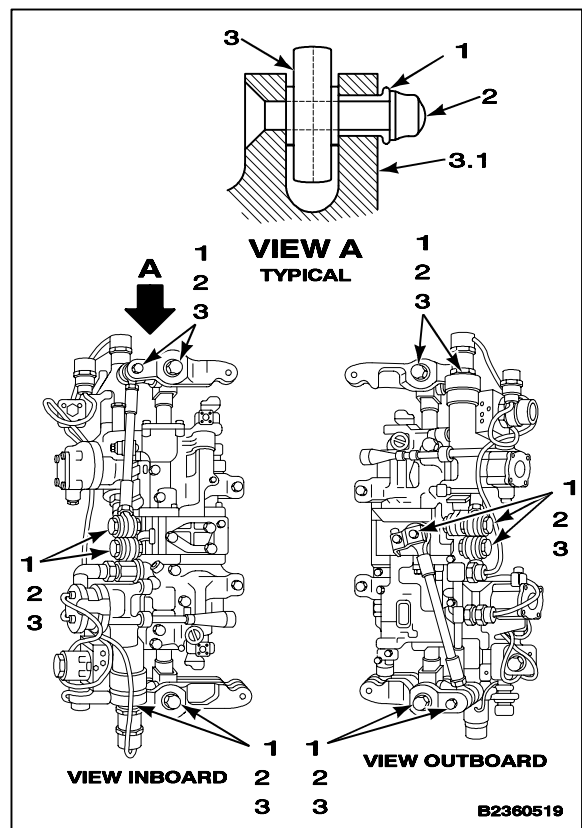

NOTE

Reading for all axial bearing checks shall not be more than **0.040 inch**.

5. Check for axial looseness between levers (4) and bearing (5) as follows:
 - a. Push and hold bolt (7).
 - b. Preload dial indicator (6) against lever and zero the indicator.
 - c. Move lever (4) towards indicator. Take reading.
6. Repeat step 5 for lever (4), bearing (8), and bolt (9).
7. Check for axial looseness between bearing housing (10) and bearing (11) as follows:
 - a. Push and hold bolt (12).
 - b. Preload dial indicator (6) against housing and zero the indicator.
 - c. Move housing (10) towards indicator. Take reading.

NOTE

Reading for all radial bearing checks shall not be more than **0.004 inch**.

8. Repeat step 5 to check for radial looseness of lever (4), bearing (5), and bolt (9).
9. Repeat step 5 to check for radial looseness of lever (4), bearing (8), and bolt (7).
10. Repeat step 5 to check for radial looseness of link (14), bearing (13), and bolt (15).

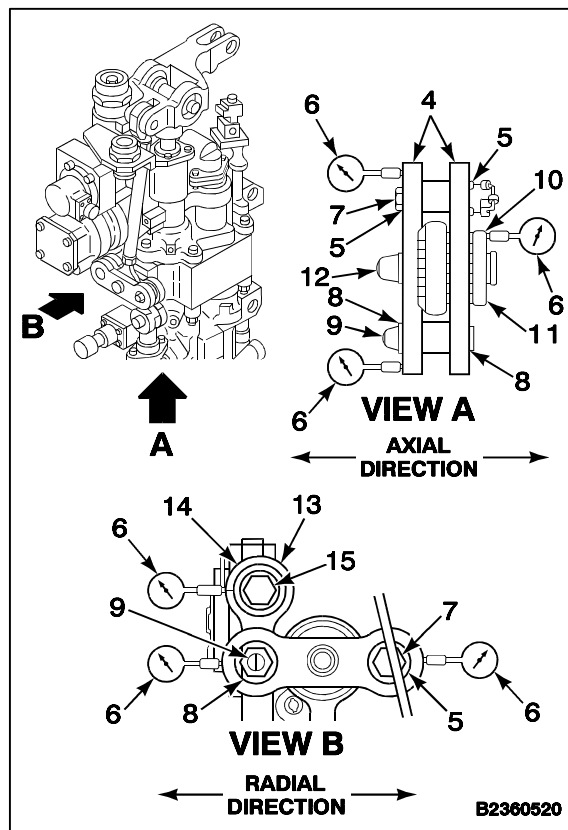

11. Check for axial looseness between lever (16) and bearings (17 and 18). Preload dial indicator (6) against lever. Push and hold bolt (19). Move lever toward, then away from, indicator. Record indicator reading. Reading shall not be greater than **0.0040 inch**.

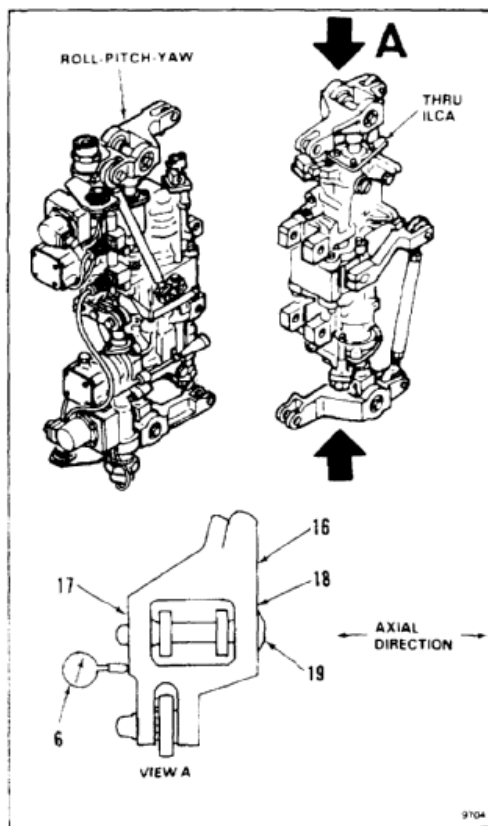

12. Check for radial looseness of rod end bearings (20). Preload dial indicator (6) against bearing. Hold lever (21). Move bearing toward, then away from, indicator. Record indicator reading. Reading shall not be more than **0.004 inch**.

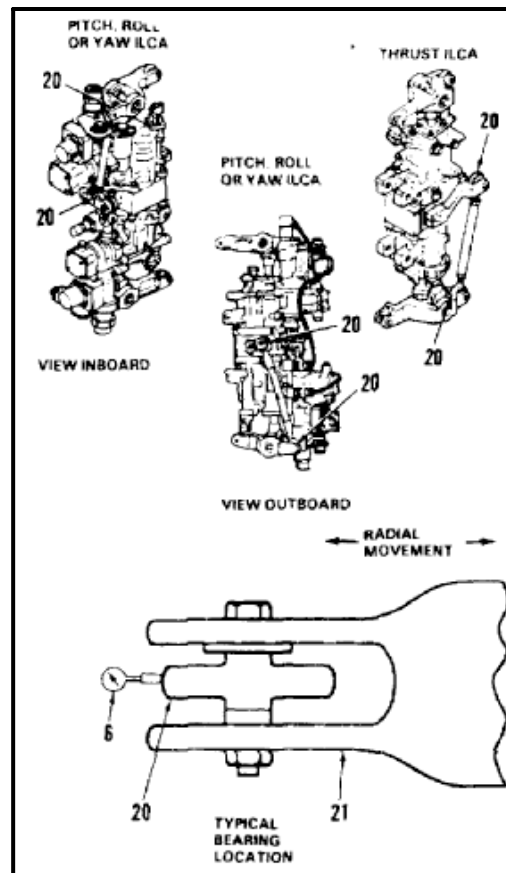

FOLLOW-ON MAINTENANCE:

None

END OF TASK

7-84 REMOVE INTEGRATED LOWER CONTROL ACTUATOR (ILCA)

7-84

INITIAL SETUP**Applicable Configurations:**

All

Tools:

Aircraft Mechanic's Tool Kit, NSN 5180-00-323-4692

Materials:

Cloths (E135)

Personnel Required:

Medium Helicopter Repairer (2)

Equipment Condition:

- Battery Disconnected (Task 1-39)
- Electrical Power Off
- Hydraulic Power Off
- Control Closet Acoustic Blanket Removed (Task 2-107)
- Controls Closet Panel Removed (Task 2-2)
- Safety Blocks Installed (Task 11-28)

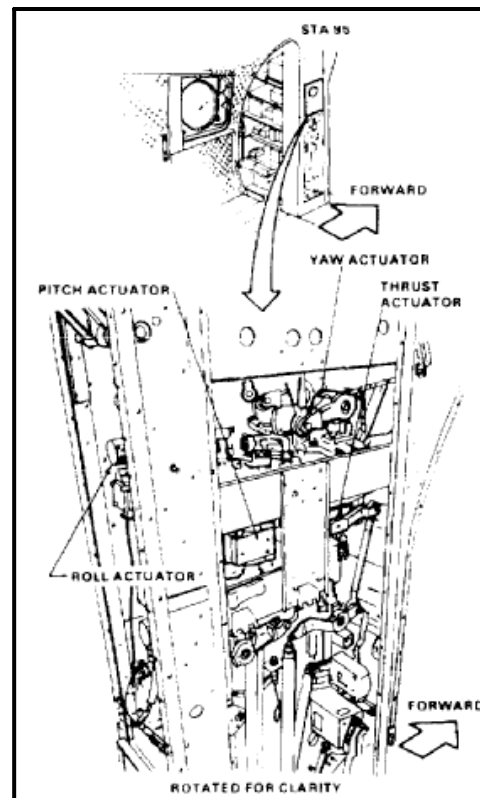

NOTE

Procedure is same to remove any integrated lower control actuator (ILCA) except where noted in text. Removal of pitch actuator is shown here.

Thrust actuator must be removed for access to yaw actuator.

There are no electrical connectors on thrust actuator.

1. Disconnect two cable connectors (1) from actuator (2).
2. Remove cotter pin (3), nut (4), three washers (5), and bolt (6) from lever (7)
3. Remove cotter pin (8), nut (9), two washers (10), bushing (11), and bolt (12) from lever (13). On roll, yaw, and thrust actuator, remove cotter pin, nut, three washers, and bolt from lever.

NOTE

There are four bolts in actuator. Two on top and two on bottom.

4. Remove lockwire from four bolts (14).
5. Have helper support actuator (2). Remove four bolts (14) and washers (15) from actuator.

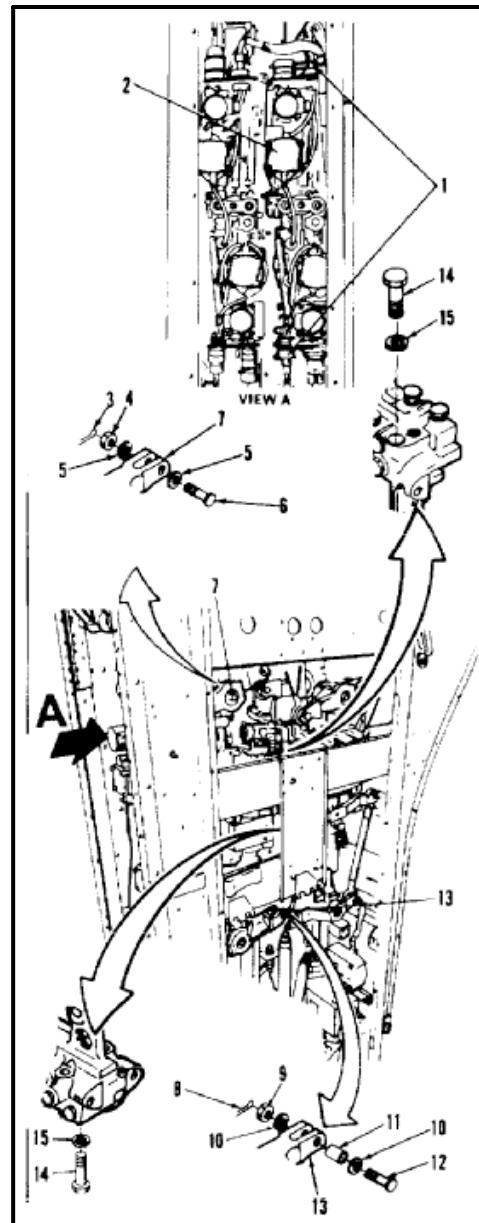

6. Remove actuator (2) from manifold (16). Use cloths (E135) for spilled fluid. Cover manifold with cloths (E135).

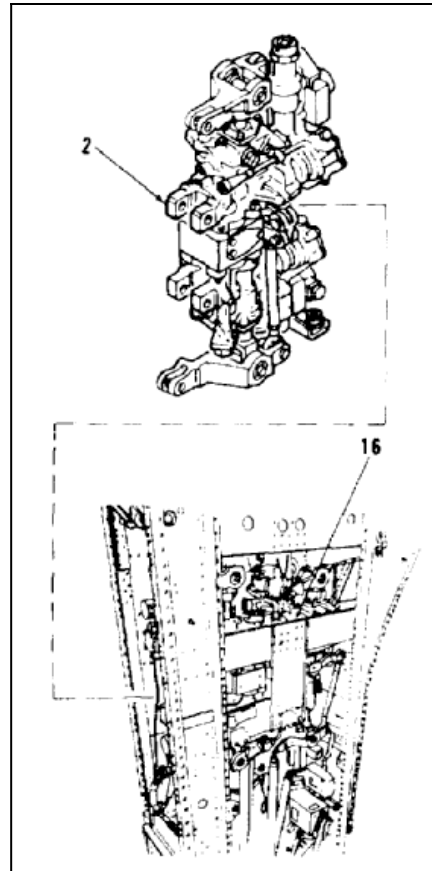

FOLLOW-ON MAINTENANCE:

None

END OF TASK

INITIAL SETUP

Applicable Configurations:

All

Tools:

Aircraft Mechanic's Tool Kit, NSN 5180-00-323-4692

Materials:Cloths (E135)
Gloves (E186)**Personnel Required:**

Medium Helicopter Repairer

Equipment Condition:Off Helicopter Task
Integrated Lower Control Actuator (ILCA) Removed
(Task 7-84)**General Safety Instructions:****WARNING**

Hydraulic fluid (E199) is toxic. It can irritate skin and cause burns. Avoid inhaling. Use only with adequate ventilation. Avoid contact with skin, eyes, or clothing. In case of contact, immediately flush skin or eyes with water for at least **15 minutes**. Get medical attention for eyes.

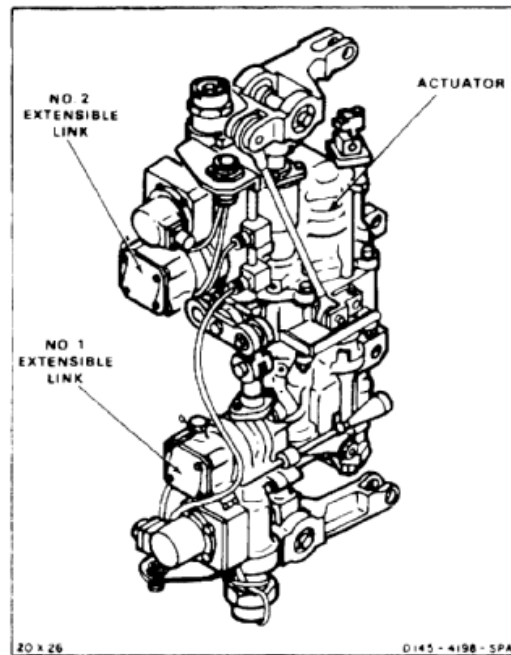

NOTE

Procedure is same to remove No. 1 or No. 2 extensible link on roll, pitch, or yaw integrated lower control actuator (ILCA). Removal of No. 2 extensible link is shown here.

1. Remove strap (1) from receptacle (2).
2. Disconnect plug (3) from receptacle (4).
3. Remove lockwire from screw (5). Remove screw from clip (6).
4. Remove tywrap (7) and grommet (8) from pressure tube (9).
5. Pull pressure tube (9) and remove from manifold (10).
6. Remove packing (11) from pressure tube (9).
7. Remove cotter pin (12), nut (13), and bolt (15) from link (16).
8. Remove lockwire from three bolts (17).
9. Remove three bolts (17) from extensible link (18).
10. Remove extensible link (18) and transfer tube (19) from manifold (10). Use cloths (E135) for spilled fluid. Wear gloves (E186).
11. Remove lockwire from transfer tube (19). Remove tube.
12. Remove packings (20) from transfer tube (19).

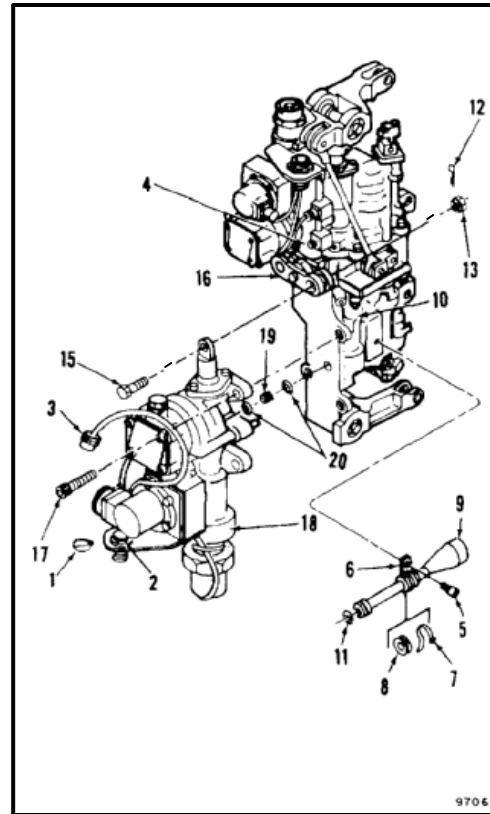
**FOLLOW-ON MAINTENANCE:**

None

END OF TASK

INITIAL SETUP

Applicable Configurations:

All

Tools:

Hydraulic Repairer's Tool Kit, NSN 5180-00-323-4891

Materials:

None

Personnel Required:

Aircraft Pneudraulics Repairer

Equipment Condition:

Off Helicopter Task
 Extensible Link Self Feedback Transducer Removed
 (Task 7-88.1)

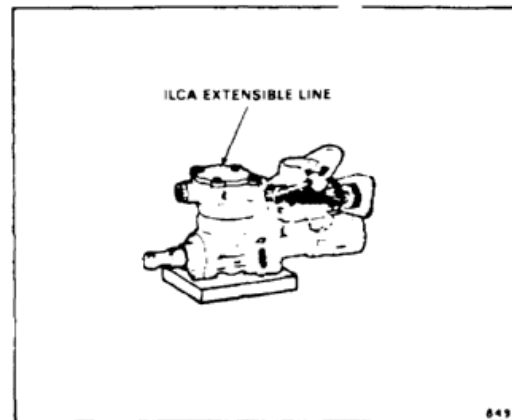
**WARNING**

Cover is spring-loaded. Remove with caution. Otherwise personal injury can occur.

1. Remove two screws (1) and wing nuts (2) from adapter (3).
2. Remove lockwire from four screws (4) of extensible link (5).
3. Remove two opposing screws (4).
4. Install two screws (1) with wing nuts (2). Tighten wing nuts against cover (6).
5. Remove remaining two screws (4).
6. Loosen two wing nuts (2). Remove two screws (4).
7. Remove cover (6) and packing (7). Set cover aside.

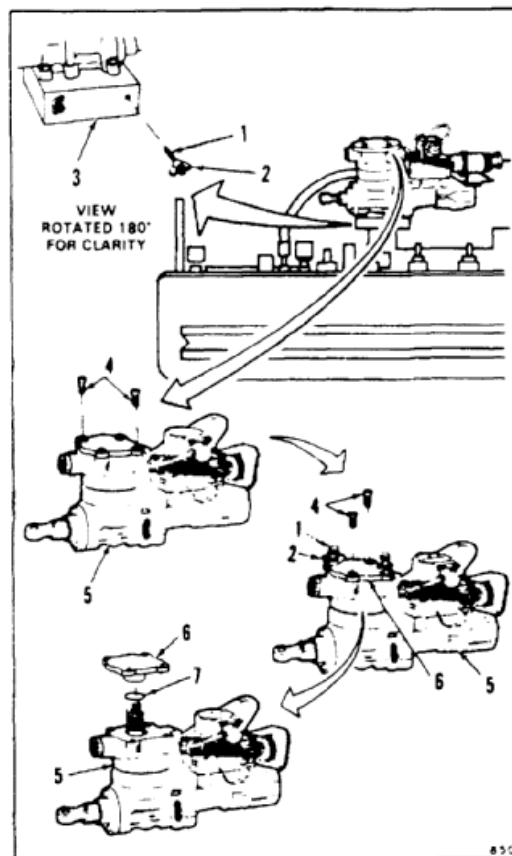

7-85.1 REMOVE PISTON SEALS — ILCA EXTENSIBLE LINK (AVIM) (Continued)

8. Remove inner and outer springs (8 and 9) from piston lock (10). Remove piston lock from link (5).

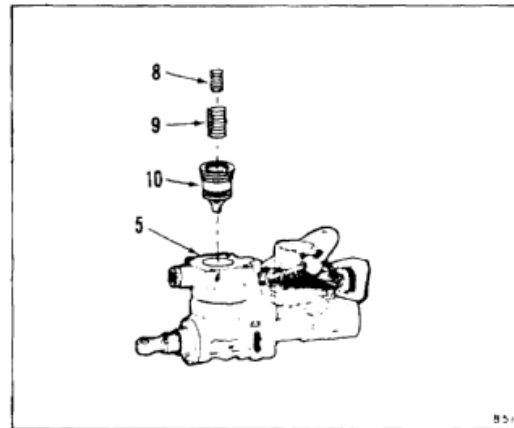

9. Remove two spacers (11 and 12) from inside piston lock (10).
10. Remove two retainers (13 and 14) and two packings (15 and 16) from piston lock (10).

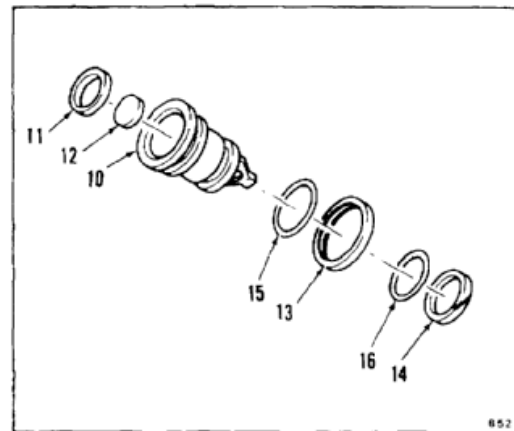

11. Remove two screws (17) from gland (18). Remove gland from link (5).
12. Push piston (19) from gland (18) end of link (5). Remove piston.

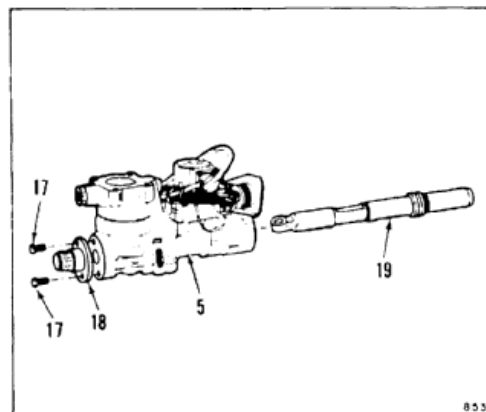

13. Remove gland (20) from piston (19).
14. Remove four packings (21) and two seals (22) from gland (20).
15. Remove ring set (23) from piston (19).

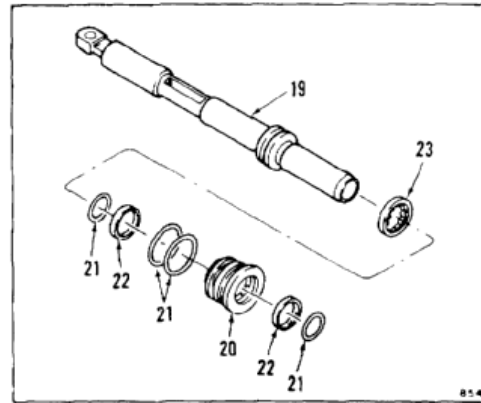

16. Remove two packings (24) and two seals (25) from bore of link (5).

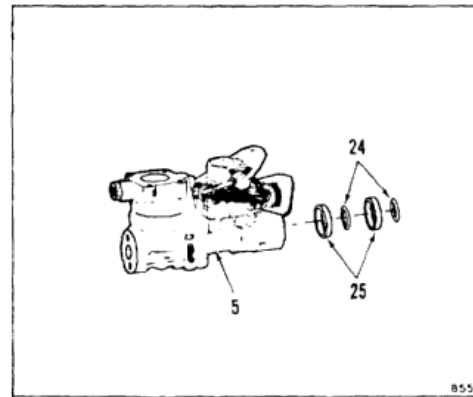

FOLLOW-ON MAINTENANCE:

None

END OF TASK

7-344

7-85.2 INSTALL PISTON SEALS — ILCA EXTENSIBLE LINK (AVIM)

7-85.2

INITIAL SETUP**Applicable Configurations:**With **21****Tools:**

Hydraulic Repairer's Tool Kit, NSN 5180-00-323-4891
 Seal Insertion Tool (APP E-51)
 Seal Installation Tool (APP E-52)

Materials:

Grease (E75)
 Gloves (E186)

Parts:

Seals
 Packings
 Retainers
 Ring Set

Personnel Required:

Aircraft Pneudraulics Repairer
 Inspector

References:

TM 55-1520-240-23P
 Task 7-88.2
 Task 7-97

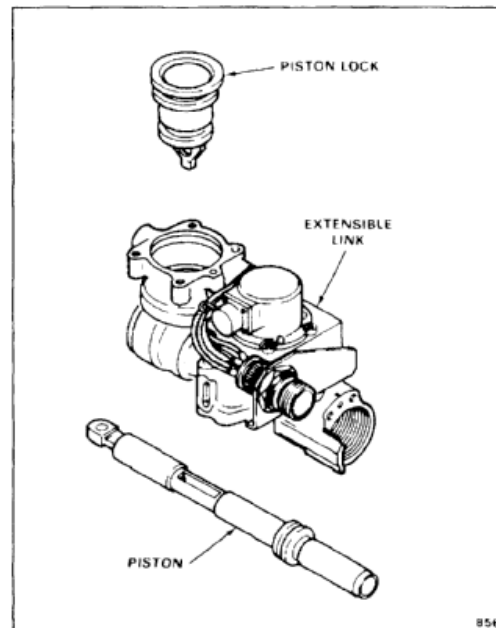

1. Install two packings (1) and two seal caps (2) in bore of extensible link (3) as follows:



Seal assembly P/N S33081-18P-99 must be used, otherwise component malfunction can occur.

- a. Remove packings (1) from two seal caps (2).
- b. Position packing (1) on insertion tool (1.1).
- c. Insert packing (1) into packing groove in bore of extensible link (3).
- d. Remove insertion tool (1.1).
- e. Insert installation tool (1.2) thru packing (1). Turn installation tool clockwise until packing is seated in packing groove.
- f. Repeat steps a thru d for remaining packing (1) and two seal caps (2).

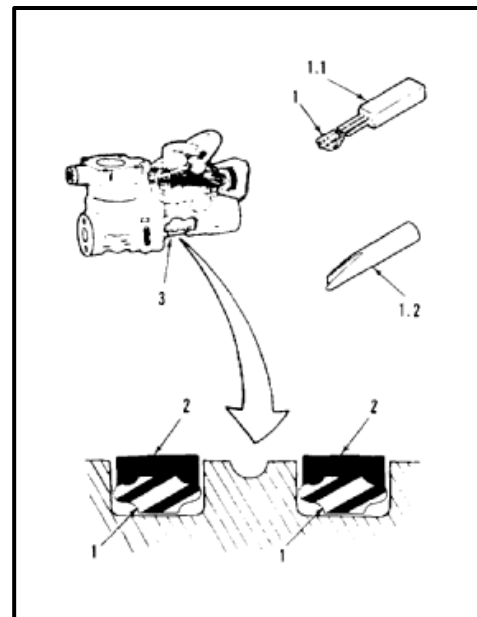

2. Install ring set (4) on piston (5) with tang (6) of spring (7) in slot (8) of ring (9).



Seal assembly P/N S33081-18P-99 must be used, otherwise component malfunction can occur.

3. Remove packings (10) from two seal caps (11).
- 3.1. Install packings (10) in bore of gland (12).
- 3.2. Install seal caps (11) in bore of gland (12).
4. Install two packings (13) on gland (12).
5. Install gland (12) on piston (5) opposite end to yoke (14), with flange (15) of gland outboard.
6. Apply compound (E75) to inside surfaces of slot (16) in piston (5). Wear gloves (E186).

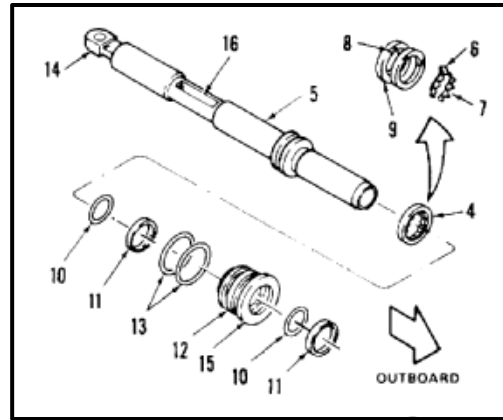

INSPECT

7. Install piston (5) in link (3), yoke (14) first. Install from electrical socket (17) end of link. Push piston until slot (16) is completely visible looking in access (18) of link.
8. Position gland (19), on piston (5), flange (20) inboard and against link (3).
9. Install two screws (21) in gland (19).

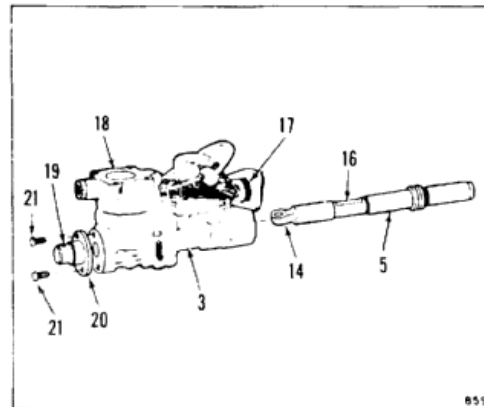

10. Install packing (22) and retainer (23) on lock piston (24), large outer diameter.
11. Install packing (25) and retainer (26) on lock piston (24), small outer diameter.
12. Install spacer (27) and spacer (28) in lock piston (24).

INSPECT

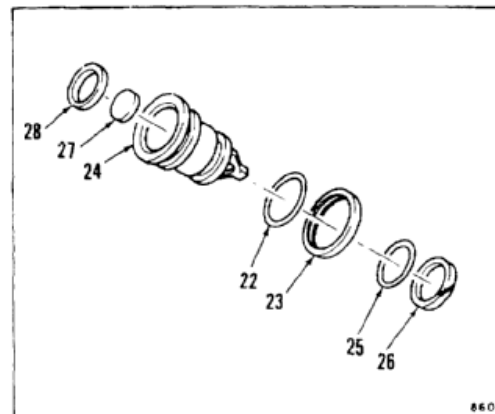

7-85.2 INSTALL PISTON SEALS — ILCA EXTENSIBLE LINK (AVIM) (Continued)

7-85.2

13. Install piston lock (24) in access (18) of link (3) with tang (29) down. Turn piston (5) until tang is fully in slot (16) of piston.
14. Install outer spring (30) and inner spring (31) in piston lock (24).

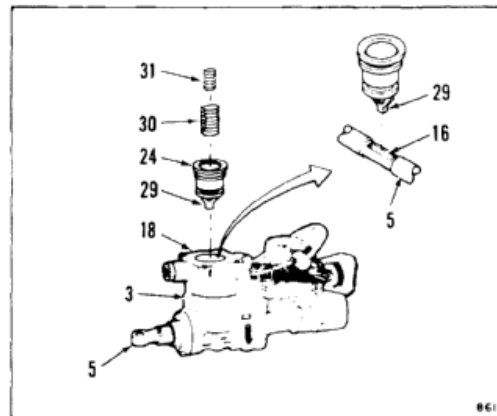
INSPECT

15. Install packing (32) on cover (33).
16. Position cover (33) on link (3). Install two screws (34). Tighten wing nuts (35).
17. Install two screws (36).
18. Remove two screws (34).
19. Install remaining two screws (36).



Do not attempt to adjust extensible self feed transducer. Damage to component can occur.

20. Install extensible link self feedback transducer (Task 7-88.2).
21. Functionally test extensible link (Task 7-97).

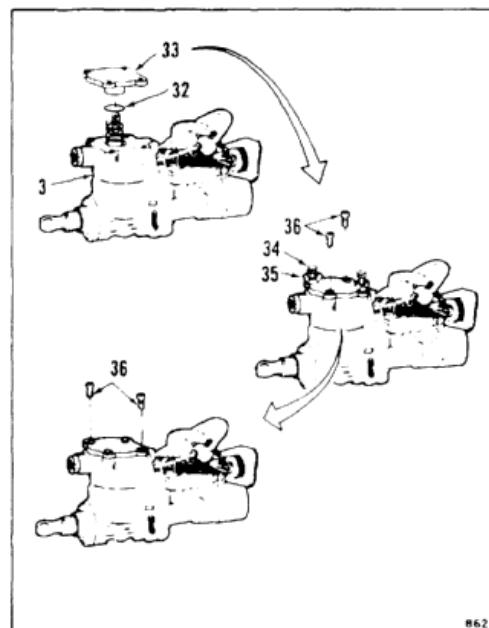
**FOLLOW-ON MAINTENANCE:**

None

END OF TASK

INITIAL SETUP

Applicable Configurations:

All

Tools:

Hydraulic Repairer's Tool Kit, NSN 5180-00-323-4891

Materials:

None

Personnel Required:

Aircraft Pneudraulics Repairer

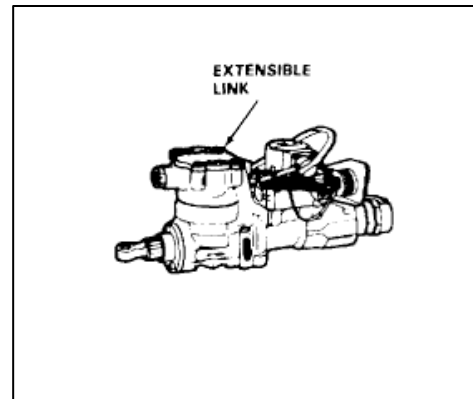
Equipment Condition:Off Helicopter Task
Extensible Link Removed (Task 7-85)**NOTE**

Procedure is same to remove pressure port filter from all extensible links.

1. Remove screen retainer (1) from extensible link (2).
2. Remove pressure port filter (3) from extensible link (2).

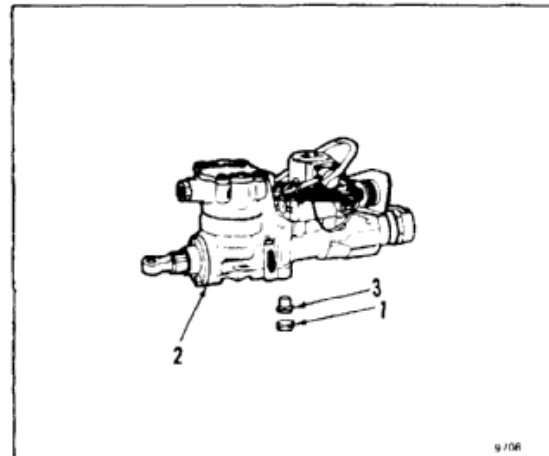
**FOLLOW-ON MAINTENANCE:**

None

END OF TASK

7-348

7-85.4 INSTALL EXTENSIBLE LINK PRESSURE PORT FILTER (AVIM)

7-85.4

INITIAL SETUP**Applicable Configurations:**

All

Tools:

Hydraulic Repairer's Tool Kit, NSN 5180-00-323-4891
Torque Wrench, 5 to 50 Inch-Pounds

Materials:

None

Personnel Required:

Aircraft Pneudraulic Repairer
Inspector

References:

TM 55-1520-240-23P

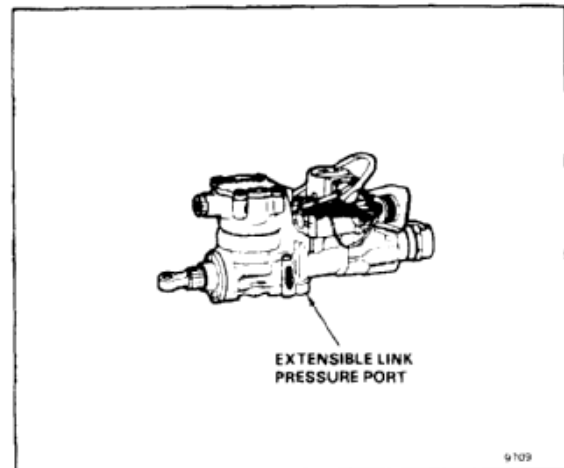
**NOTE**

Procedure is same to install pressure port filter in all extensible links.

1. Install pressure port filter (1), small diameter inward, in extensible link (2).
2. Install screen retainer (3) in extensible link (2). Torque retainer to **30 inch-pounds**.

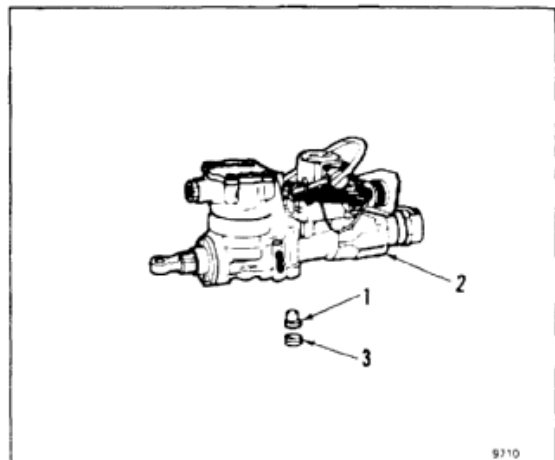
INSPECT**FOLLOW-ON MAINTENANCE:**

None

END OF TASK

INITIAL SETUP

Applicable Configurations:

All

Tools:

Aircraft Mechanic's Tool Kit, NSN 5180-00-323-4692
Torque Wrench, 30 to 150 Inch-Pounds

Materials:

Lockwire (E231)
Paper Tags (E264)
Strap (E376)

Parts:

Prefomed Packings
Cotter Pin

Personnel Required:

Medium Helicopter Repairer
Inspector

References:

TM 55-1520-240-23P

General Safety Instructions:**WARNING**

AFCS extensible links are not directly interchangeable from one axis to another axis without changing authority covers. Authority covers and resultant piston strokes are different. Direct interchanging of links can result in dangerous flight characteristics.

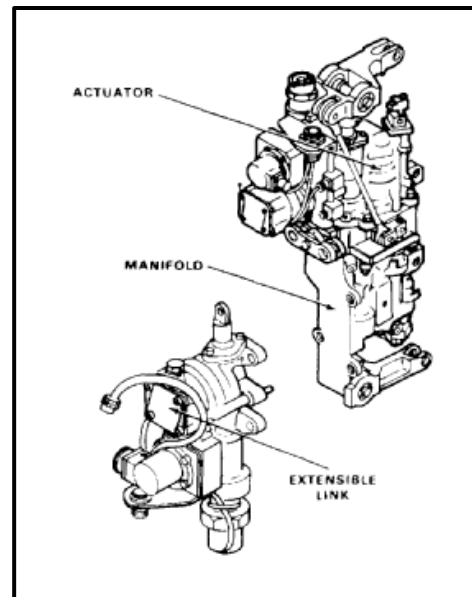

TABLE A

NOTE

Links 145H7350-8 and -12 are interchangeable with links 145H7350 series in any axis when authority cover is removed from faulty unit and installed on replacement unit.

SPARE PART NO.	AUTHORITY COVER PART NO.	DIMENSION A (SEE FIG.)	NEW PART NO.	CONTROL AXIS
145H7350-8	145H7357-1	0.721	145H7350-5	PITCH
145H7350-8	145H7357-2	0.671	145H7350-6	ROLL
145H7350-8	145H7357-3	0.551	145H7350-7	YAW
145H7350-12	145H7357-1	0.721	145H7350-9	PITCH
145H7350-12	145H7357-2	0.671	145H7350-10	ROLL
145H7350-12	145H7357-3	0.551	145H7350-11	YAW

WARNING

Replacement extensible link has shipping cover in place of authority cover. Authority cover from removed link must be installed on replacement link.

1. On replacement (spare) extensible link (1), remove shipping cover (2) as follows:
 - a. Remove lockwire from four screws (3).

WARNING

Cover is spring-loaded. Remove with caution, otherwise personnel injury can occur.

- b. Apply hand pressure to data plate (4) and remove four screws (3).
 - c. Remove and tag data plate (4) and shipping cover (2).
 - d. Erase or cover over -8 or -12 number on replacement link data plate (4). Stamp dash number and axis identification of replaced extensible link on replacement link data plate (4). (See table A.)

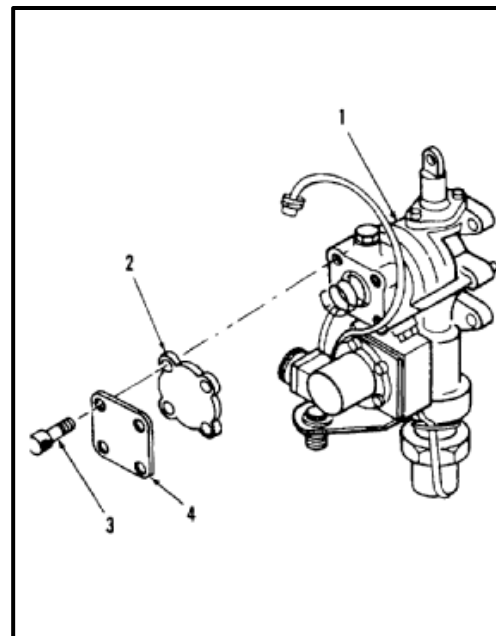

2. On removed extensible link (5), remove authority cover (6) as follows:

- a. Remove lockwire from four screws (7).

WARNING

Cover is spring-loaded. Remove with caution, otherwise personnel injury can occur.

- b. Apply hand pressure to cover (6). Remove four screws (7) from cover.
- c. Remove and tag data plate (8) and authority cover (6). Remove and discard packing (8.1).
- d. Erase or cover over -5 thru -11 dash number and axis identification, and stamp -8 or -12 on data plate (8).

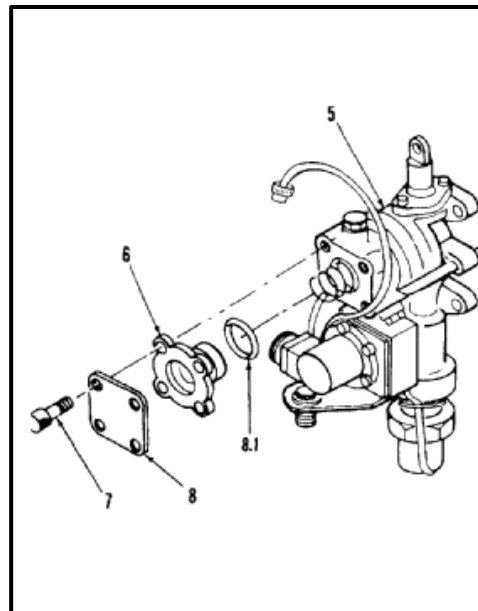

3. On replacement extensible link (1), install authority cover (6) as follows:

NOTE

Make sure data plate is marked with correct dash number and corresponding axis identification as shown in table A.

- a. Remove tag from data plate (4). Position new packing (8.1), authority cover (6), and data plate on link (1).
- b. Install four screws (7). Torque to **30 inch-pounds**.
- c. Lockwire screws (7). Use lockwire (E231).

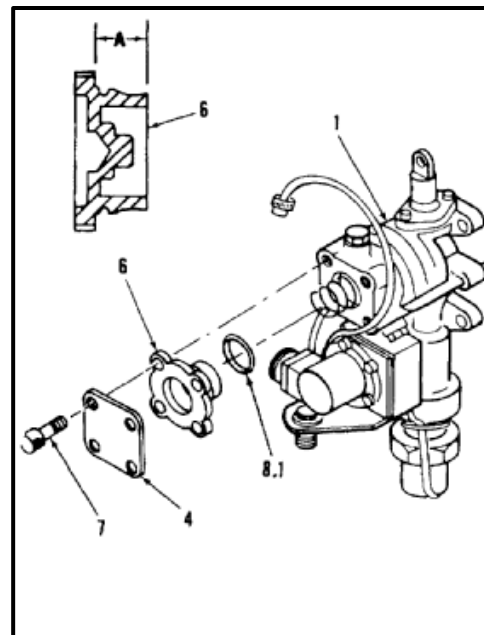

4. On removed extensible link (5), install shipping cover (2) as follows:

NOTE

Make sure dash number on data plate (8) is -8 or -12.

- a. Position shipping cover (2) and data plate (8) on link (5).
- b. Install four screws (3).
- c. Lockwire screws (3). Use lockwire (E231).

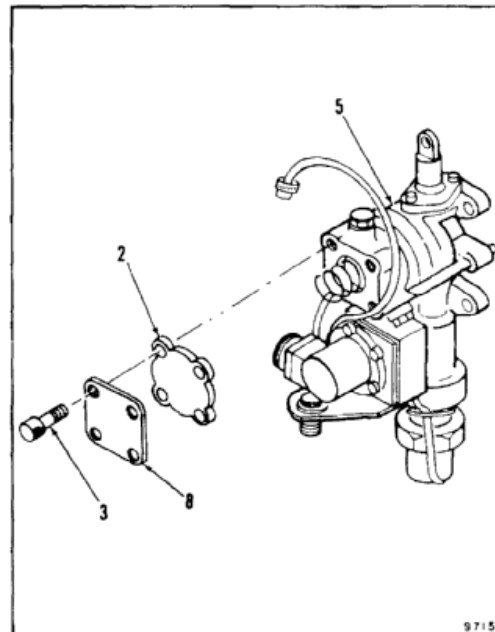

5. Install packing (9) on tube (10).
6. Install two packings (11) on transfer tube (12).
- 6.1. Install transfer tube (12) in extensible link (1). Lockwire tube to link. Use lockwire (E231).
7. Position extensible link (1) on actuator (13).
8. Install two screws (14) and screw (15) in assembly (1).
9. Torque two screws (14) and screw (15) to **45 inch-pounds**.
10. Lockwire screws (14 and 15). Use lockwire (E231).
11. Position rod (16) in link (17). Install bolt (18) and nut (20).
12. Torque nut (20) to **35 to 65 inch-pounds**.
13. Install cotter pin (21).
14. Install tube (10) in extensible link.
15. Install grommet (22) and tie-rop (23) on tube (10).
16. Install screw (24) in clip (25) and actuator (13).
17. Connect cable plug (26) to receptacle (27).
18. Identify strap (28) with correct axis and install on receptacle (29). (See Table A.)

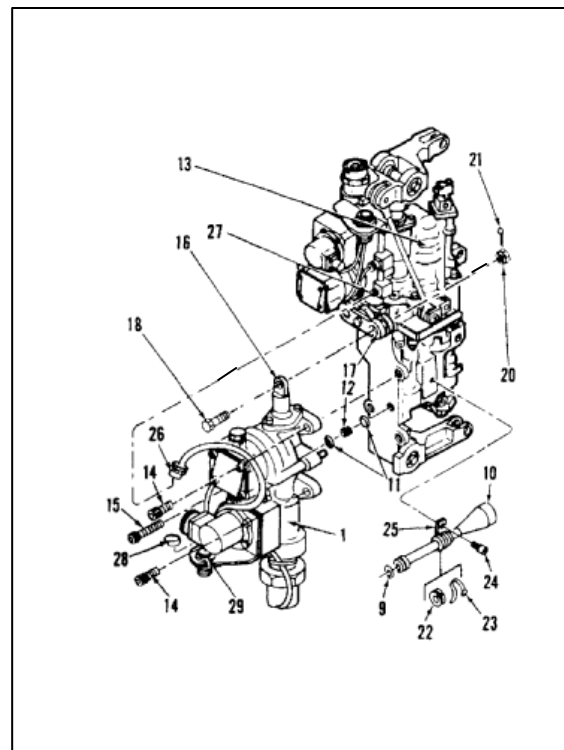
**INSPECT****FOLLOW-ON MAINTENANCE:**

Perform ILCA test (Task 7-98).

END OF TASK

INITIAL SETUP

Applicable Configurations:

All

Tools:

Hydraulic Repairer's Tool Kit, NSN 5180-00-323-4891

Materials:

Paper Tags (E264)

Personnel Required:

Aircraft Pneudraulics Repairer

Equipment Condition:

Off Helicopter Task

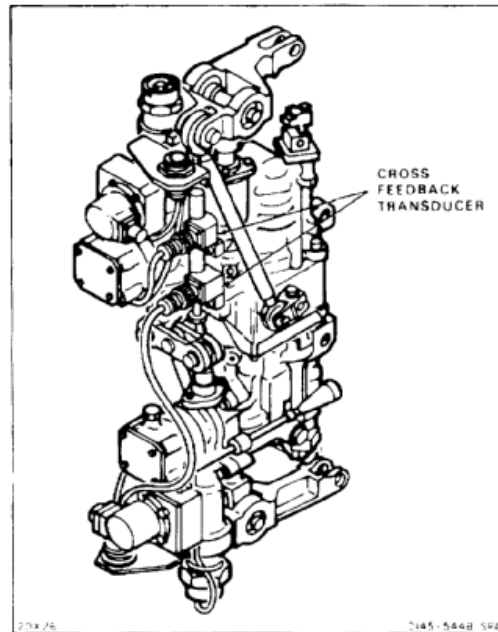
**NOTE**

Procedure is same to remove cross feedback transducer on roll, pitch, or yaw actuator.

1. Tag and disconnect two electrical plugs (1) from transducer (2).
2. Remove lockwire from two screws (3) and locknut (4).

NOTE

Count number of turns needed to remove probe.

3. Loosen locknut (4) and remove probe (5) from rod end (6). Count number of turns to remove probe and record.
4. Remove two screws (3).
5. Remove transducer (2).
6. Remove nut (4) from probe (5). Retain nut for installation.

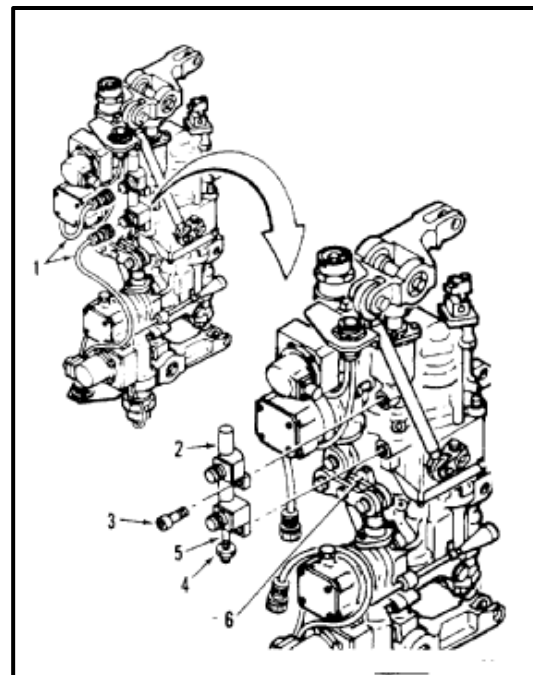
**FOLLOW-ON MAINTENANCE:**

None

END OF TASK

7-354

7-88 INSTALL INTEGRATED LOWER CONTROL ACTUATOR (ILCA) CROSS FEEDBACK TRANSDUCER (AVIM)

7-88

INITIAL SETUP
Applicable Configurations:

All

Tools:

Hydraulic Repairer's Tool Kit, NSN 5180-00-323-4891
Torque Wrench, 5 to 50 Inch-Pounds

Materials:

Lockwire (E231)

Personnel Required:

Aircraft Pneudraulics Repairer
Inspector

References:

TM 55-1520-240-23P
Task 7-98

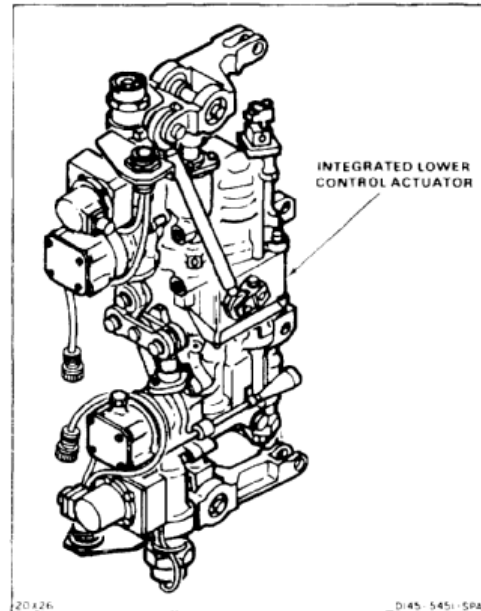
NOTE

Procedure is same to install cross feedback transducer on roll, pitch, or yaw actuator.

1. Install nut (1) on probe (2).
2. Position transducer (3) on actuator (4). Install two screws (5).
3. Torque two screws (5) to **23 inch-pounds**.
4. Lockwire screws (5) to actuator (4). Use lockwire (E231).
5. Install probe (2) in rod end (6). Turn probe into rod end same number of turns as recorded. If number of turns is not available, turn probe into rod end until distance from end of rod end to transducer housing (7) is **1.175 inches** (as shown).
6. Perform Extensible Link Self Feedback Transducer Null Voltage Test (SPARE) (Task 7-98).
7. Torque nut (1) to **23 inch-pounds**. Lockwire nut to probe (2) and rod end (6). Use lockwire (E231).

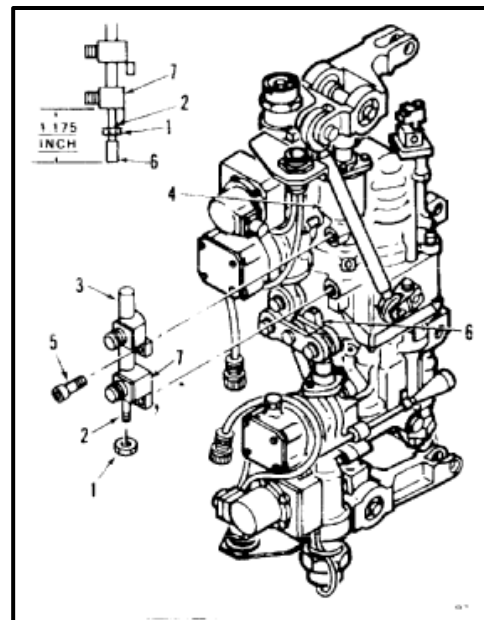

8. Connect two electrical plugs (8) to transducer
 (3). Remove tags.

INSPECT

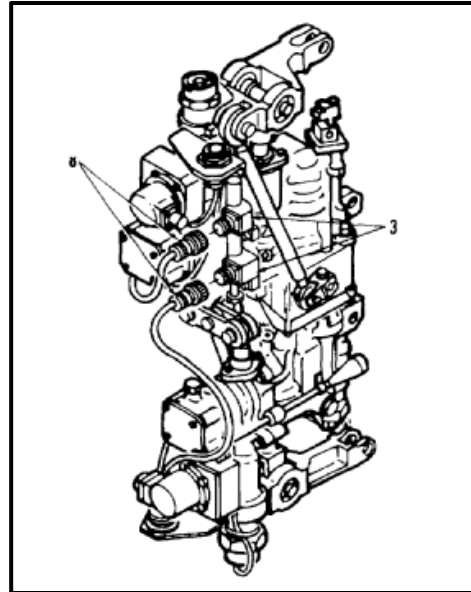

FOLLOW-ON MAINTENANCE:

Perform ILCA test (Task 7-98).

END OF TASK

7-88.1 REMOVE EXTENSIBLE LINK SELF FEEDBACK TRANSDUCER (AVIM)

7-88.1

INITIAL SETUP**Applicable Configurations:**

All

Tools:

Integrated Lower Controls Actuator Bench Test Set
145GS278-1
Hydraulic Repairer's Tool Kit, NSN 5180-00-323-4891
Torque Wrench, 30 to 150 Inch-Pounds
Contact Removal/Insertion Tool, M83723/20
Contact Removal/Insertion Tool, M81969/1403

Materials:

None

Personnel Required:

Aircraft Pneudraulics Repairer
Avionic Navigation and Flight Control Equipment
Repairer

Equipment Condition:

Off Helicopter Task
Integrated Lower Controls Actuator Installed on Test
Set (Task 7-98 Test 1 or 2) or Extensible Link
Installed on Test Set (Task 7-97 Test 1 Preliminary
Procedure)

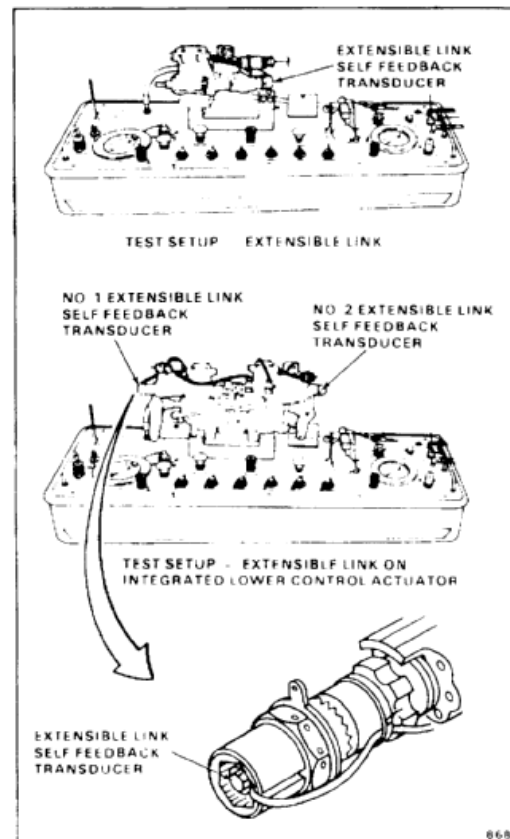

NOTE

Removal of transducer can be performed on No. 1 or No. 2 extensible link installed on actuator or with extensible link removed from actuator. No. 2 extensible link on actuator is shown.

1. Remove lockwire from two screws (1) of bracket (2).
2. Remove screw (3) from wire (4) and bracket (2). Remove wire.
3. Remove lockwire from locknut (5). Remove locknut from receptacle (6).
4. Remove receptacle (6) from bracket (2).
5. Cut and remove strap (7) from backshell (8).
6. Remove backshell (8) from receptacle (6).
7. Tag and disconnect four wires (9) from pins No. 1, 2, 3, and 4 of backshell (8). Use removal/insertion tool.
8. Cut and remove strap (10) from support (11).
9. Remove lockwire from retainer (12) and washer (13). Remove retainer, turn counterclockwise.
10. Remove two washers (13 and 14).
11. Remove lockwire from support (11) and link body (15). Remove support by turning it counterclockwise.

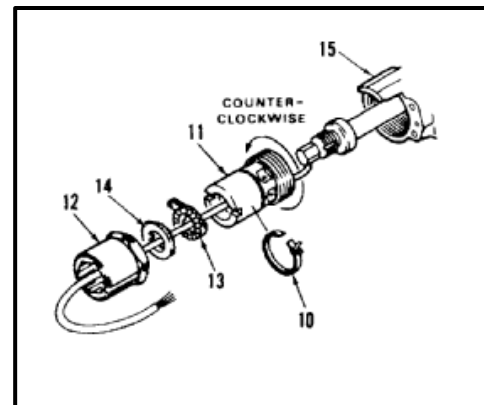
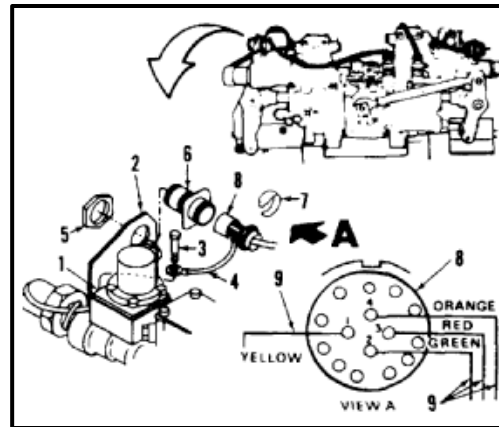

7-88.1 REMOVE EXTENSIBLE LINK SELF FEEDBACK TRANSDUCER (AVIM) (Continued)

7-88.1



Do not bend transducer.

12. Remove transducer (16) from body (15) by turning it counterclockwise.

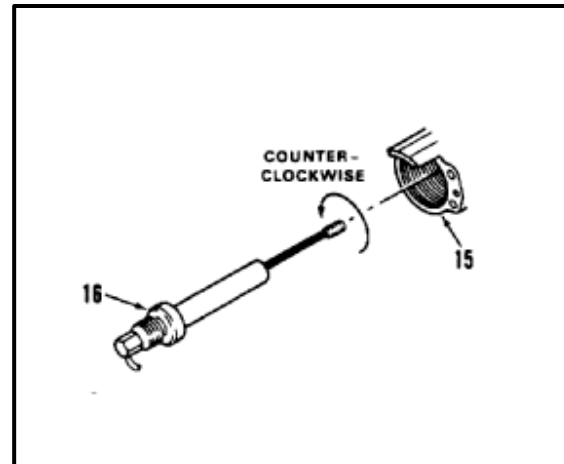
***FOLLOW-ON MAINTENANCE:***

None

END OF TASK

INITIAL SETUP

Applicable Configurations:

All

Tools:

Hydraulic Repairer's Tool Kit, NSN 5180-00-323-4891
 Torque Wrench, 30 to 150 Inch-Pounds
 Contact Removal/Insertion Tool, M83723/20
 Contact Removal/Insertion Tool, M81969/1402
 Crowfoot, 1-1/4 Inch

Materials:

None

Personnel Required:

Aircraft Pneudraulics Repairer
 Avionic Navigation and Flight Control Equipment
 Repairer
 Inspector

References:

TM 55-1520-240-23P
 Task 7-101

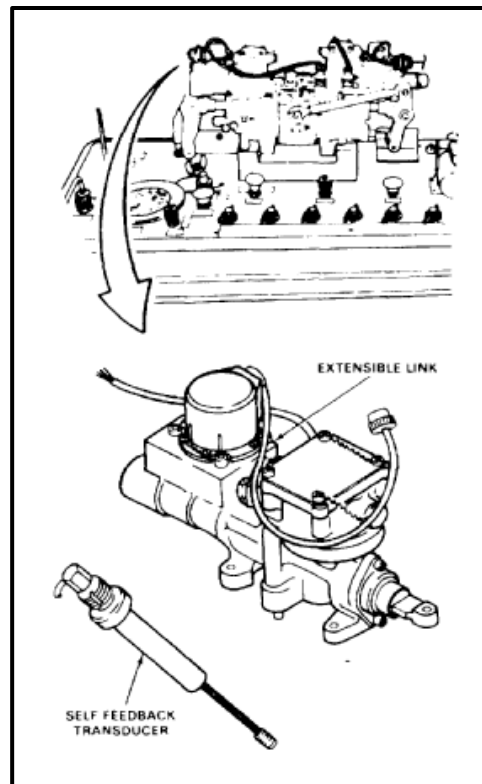
**NOTE**

Installation of transducer can be performed on No. 1 or No. 2 extensible link installed on actuator or with extensible link removed from actuator. No. 2 extensible link on actuator is shown.



Do not bend transducer.

1. Install self feedback transducer (1) in extensible link body (2) until threads (3) engage, then turn clockwise **8 turns**.

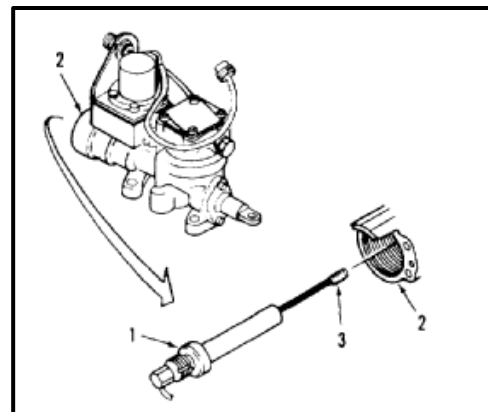

7-88.2 INSTALL EXTENSIBLE LINK SELF FEEDBACK TRANSDUCER (AVIM) (Continued)**7-88.2**

2. Pass cable (4) through support (5). Install support in body (2). Torque support to **150 inch-pounds**.
3. Pass cable (4) through washer (6) smooth surface inward. Mount washer on support (5), tang (7) in slot (8) of support.
4. Pass cable (4) through washer (9) smooth surface outward. Mount washer on transducer (1) with tang (10) in slot (11).
5. Pass cable (4) through retainer (12). Mount retainer (12) on transducer (1). Do not tighten. Washers (6 and 9) must be apart.
6. Adjust extensible link self feedback transducer (1) (Task 7-101).

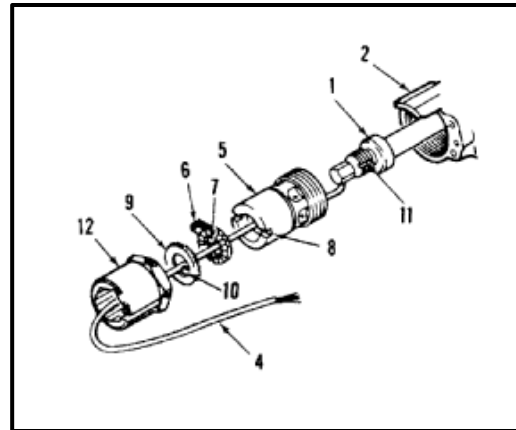
**INSPECT****FOLLOW-ON MAINTENANCE:**

None

END OF TASK

INITIAL SETUP

Applicable Configurations:

All

Tools:

Aircraft Mechanic's Tool Kit, NSN 5180-00-323-4692

Materials:Cloths (E135)
Gloves (E186)**Personnel Required:**

Medium Helicopter Repairer

Equipment Condition:

Off Helicopter Task

General Safety Instructions:**WARNING**

Hydraulic fluid (E199) is toxic. It can irritate skin and cause burns. Avoid inhaling. Use only with adequate ventilation. Avoid contact with skin, eyes, or clothing. In case of contact, immediately flush skin or eyes with water for at least **15 minutes**. Get medical attention for eyes.

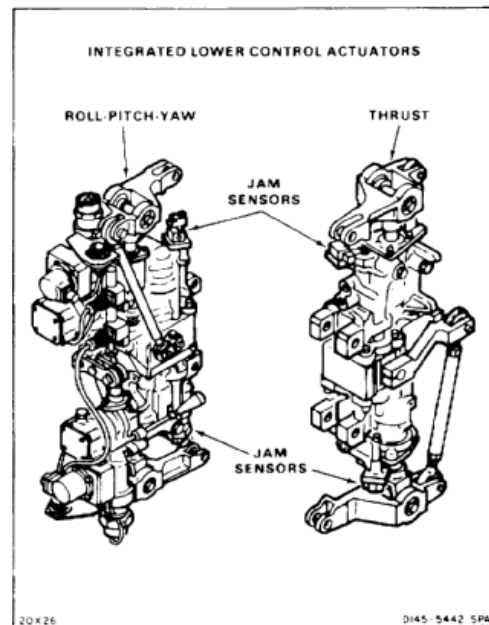

7-89 REMOVE INTEGRATED LOWER CONTROL ACTUATOR (ILCA) JAM SENSOR (AVIM) (Continued)

7-89

NOTE

Procedure is same to remove jam sensor on roll, pitch or yaw, and thrust actuators.

1. Remove lockwire from four screws (1).
 2. Remove four screws (1) from sensor (2).
-
3. Remove sensor (2) and packing (3) from actuator (4). Use cloths (E135) for spilled fluid. Use gloves (E186).

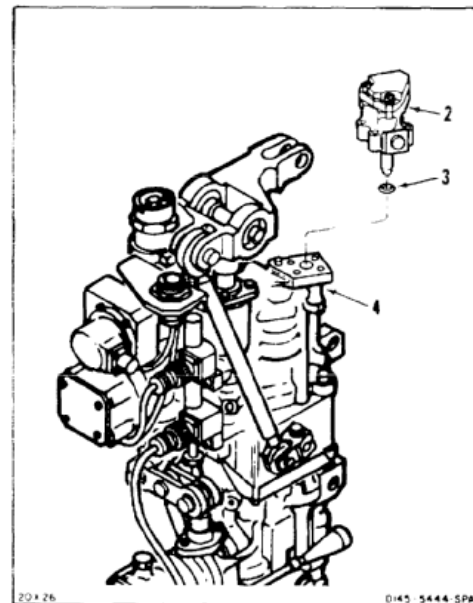
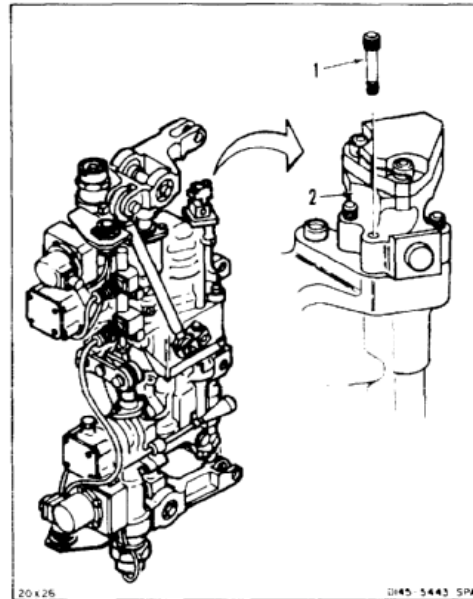
**FOLLOW-ON MAINTENANCE:**

None

END OF TASK

INITIAL SETUP

Applicable Configurations:

All

Tools:

Hydraulic Repairer's Tool Kit, NSN 5180-00-323-4891
Torque Wrench, 0 to 50 Inch-Pounds

Materials:

Lockwire (E229)

Parts:

Preformed Packing

Personnel Required:

Aircraft Pneudraulics Repairer
Inspector

References:

TM 55-1520-240-23P

NOTE

Procedure is same to install jam sensor on roll, pitch or yaw, and thrust actuator.

1. Position sensor (1) and packing (2) on actuator (3). Install four screws (4). Torque screws to **16 inch-pounds**.
2. Lockwire four screws (4). Use lockwire (E229).

INSPECT**FOLLOW-ON MAINTENANCE:**

Perform ILCA test (Task 7-98).

END OF TASK

7-364

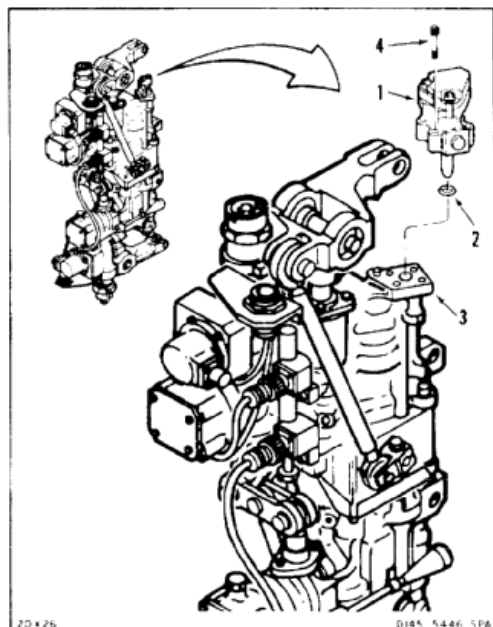
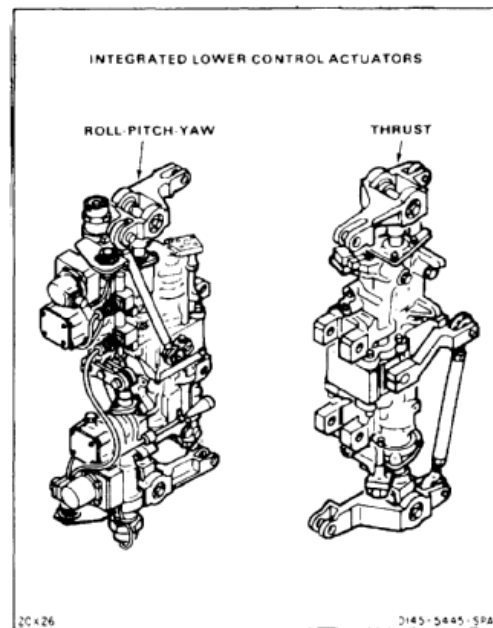

INITIAL SETUP

General Safety Instructions:

Applicable Configurations:

All

Tools:

Aircraft Mechanic's Tool Kit, NSN 51 80-00-323-4692

Materials:

Cloths (E135)
Gloves (E186)

Personnel Required:

Medium Helicopter Repairer

Equipment Condition:

Off Helicopter Task

WARNING

Hydraulic fluid (E199) is toxic. It can irritate skin and cause burns. Avoid inhaling. Use only with adequate ventilation. Avoid contact with skin, eyes, or clothing. In case of contact, immediately flush skin or eyes with water for at least **15 minutes**. Get medical attention for eyes.

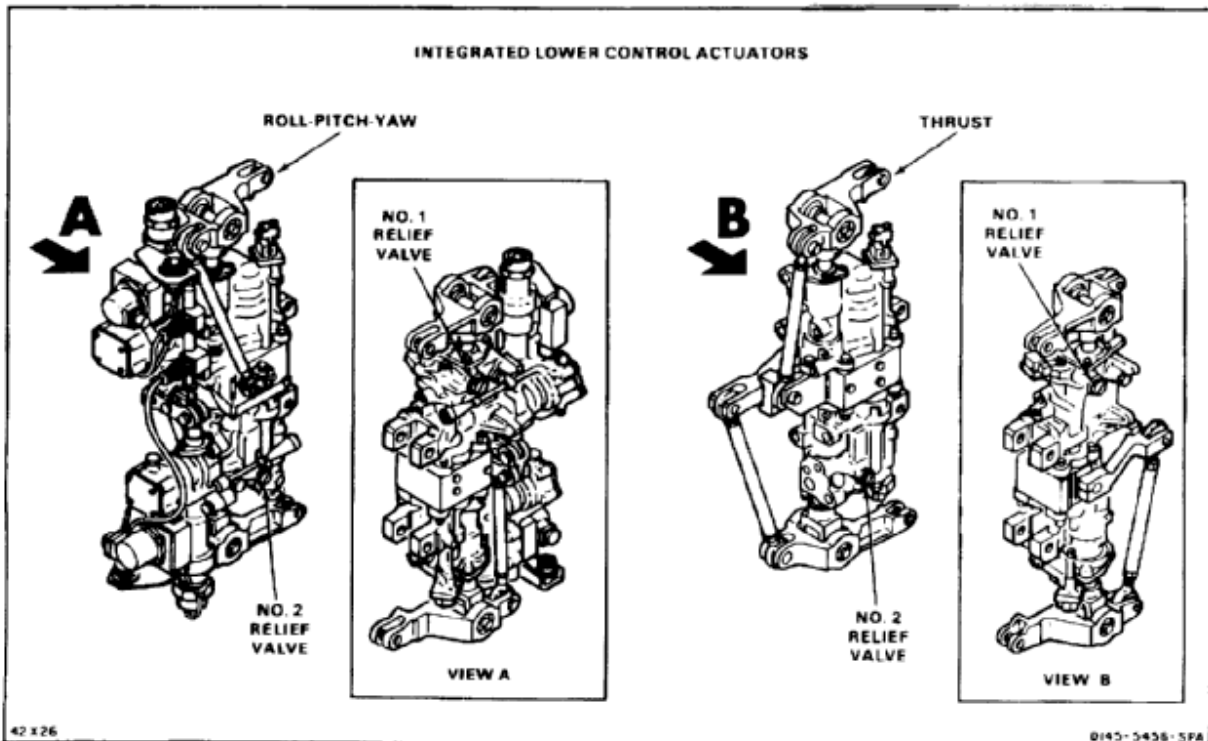

NOTE

Procedure is same to remove No. 1 or No. 2 relief valve from roll, pitch, yaw, or thrust actuator. Removal of No. 1 valve is shown here.

1. Remove lockwire from relief valve (1) and check valve (2).
2. Remove sealant from valve (1).
3. Remove valve (1) and packing (3) from actuator (4). Use cloths (E135) for spilled fluid.

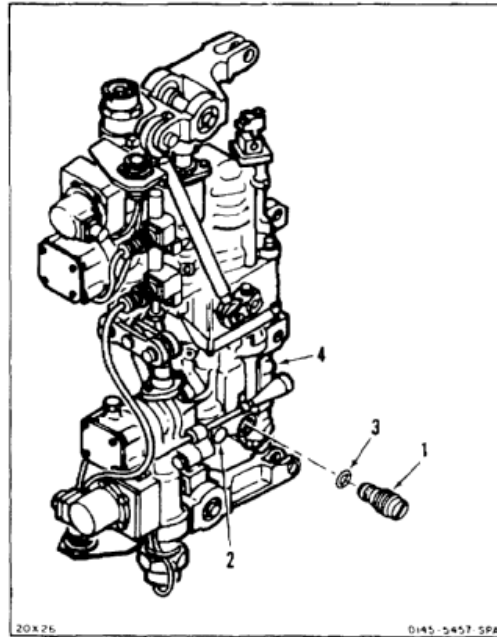
**FOLLOW-ON MAINTENANCE:**

None

END OF TASK

7-366

INITIAL SETUP

Applicable Configurations:

All

Tools:

Aircraft Mechanic's Tool Kit, NSN 51 80-00-323-4692

Materials:

- Acetone (E20)
- Cloths (E135)
- Lockwire (E231)
- Sealant (E336)
- Gloves (E186)

Parts:

Preformed Packing

Personnel Required:

Medium Helicopter Repairer
Inspector

References:

TM 55-1520-240-23P

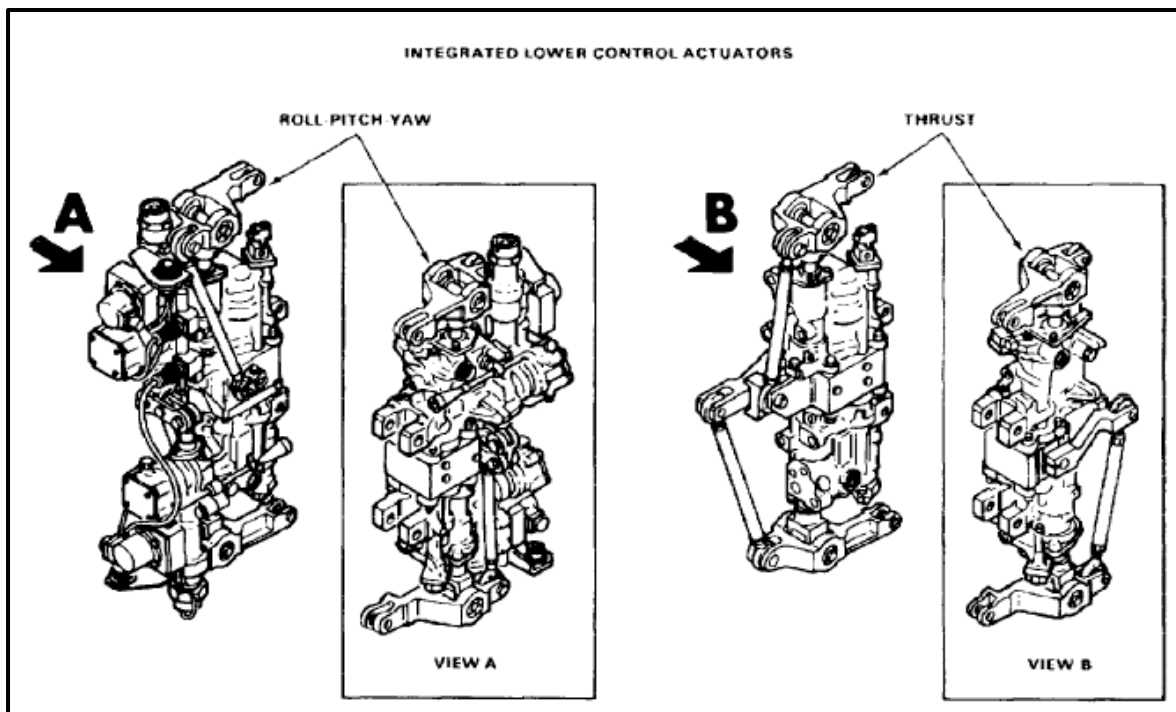

WARNING

Acetone (E20) is flammable and toxic. It can irritate skin and cause burns. Use only in well-ventilated area, away from heat and open flame. In case of contact, immediately flush skin or eyes with water for at least **15 minutes**. Get medical attention for eyes.

1. Clean sealant from area of port (1). Use acetone (E20) and cloths (E135). Wear goggles and gloves (E186).

NOTE

Procedure is same to install No. 1 or No. 2 relief valve on roll, pitch, yaw, or thrust actuator. No. 1 valve is shown here.

2. Install packing (2) on relief valve (3).
3. Install valve (3) in port (1). Torque valve to **15 to 20 inch-pounds**.
4. Apply bead of sealant (E336) around valve (3). Wear goggles and gloves (E186).

WARNING

Sealant (E336) can irritate skin and cause burns. Avoid contact with skin, eyes, and clothing. In case of contact, immediately flush skin or eyes with water for at least **15 minutes**. Get medical attention for eyes.

5. Lockwire relief valve (3) to check valve (4). Use lockwire (E231).

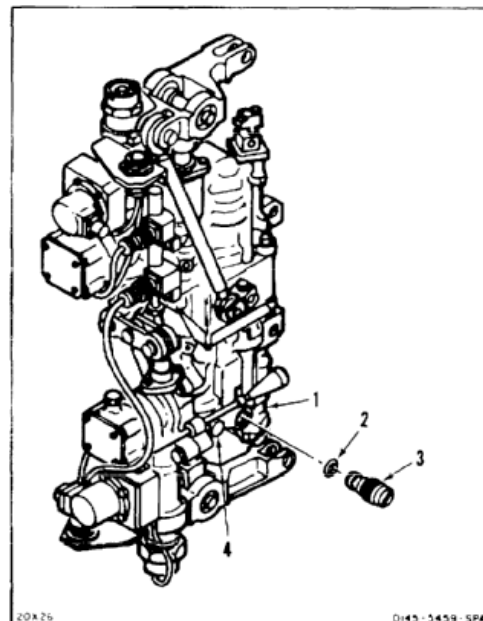
**FOLLOW-ON MAINTENANCE:**

Test ILCA (Task 7-98).

END OF TASK

7-368

7-93 REMOVE INTEGRATED LOWER CONTROL ACTUATOR (ILCA) CHECK VALVE (AVIM)

7-93

INITIAL SETUP**Applicable Configurations:**

All

Tools:

Hydraulic Repairer's Tool Kit, NSN 5180-00-323-4891

Materials:Cloths (E135)
Gloves (E186)**Personnel Required:**

Aircraft Pneudraulics Repairer

Equipment Condition:

Off Helicopter Task

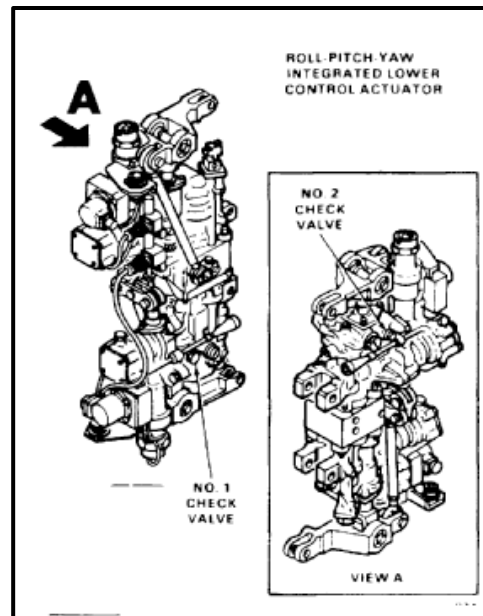
**NOTE**

Procedure is same to remove No. 1 or No. 2 check valve from roll, pitch, or yaw actuator. Removal of No. 1 valve is shown here.

1. Remove lockwire from check valve (1) and relief valve (2).
2. Remove valve (1) and packings (3) from actuator (4). Use cloths (E135) for spilled fluid. Wear gloves (E186).

FOLLOW-ON MAINTENANCE:

None

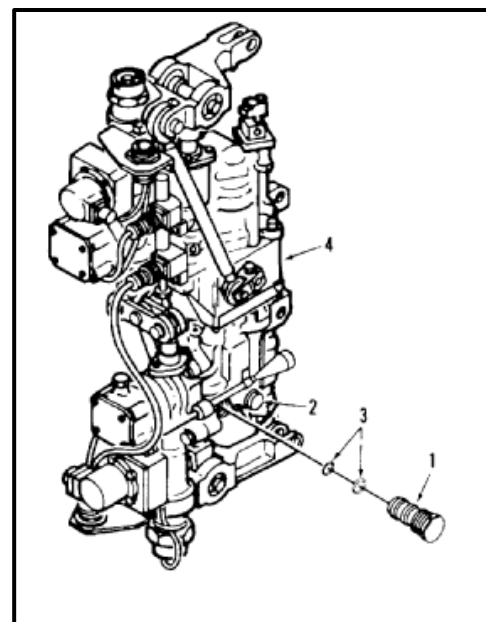

END OF TASK

INITIAL SETUP

Applicable Configurations:

All

Tools:

Hydraulic Repairer's Tool Kit, NSN 5180-00-323-4891
Goggles
Torque Wrench, 5 to 50 Inch-Pounds

Materials:

Acetone (E20)
Cloths (E135)
Lockwire (E231)
Sealant (E336)
Gloves (E186)

Parts:

Preformed Packing

Personnel Required:

Aircraft Pneudraulics Repairer
Inspector

References:

TM 55-1520-240-23P

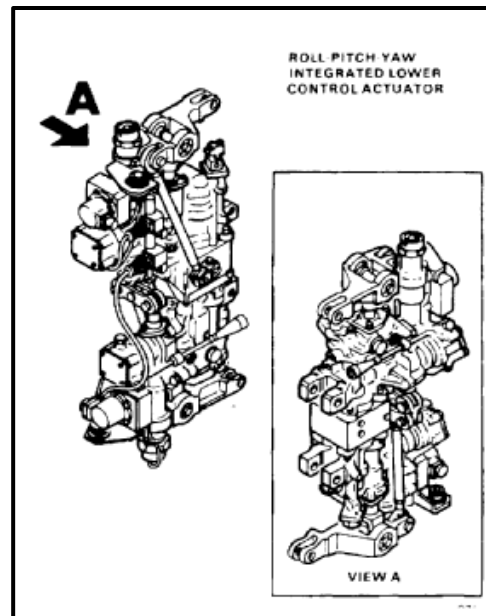

7-94 INSTALL INTEGRATED LOWER CONTROL ACTUATOR (ILCA) CHECK VALVE (AVIM) (Continued)

7-94

WARNING

Acetone (E20) is flammable and toxic. It can irritate skin and cause burns. Use only in well-ventilated area, away from heat and open flame. In case of contact, immediately flush skin or eyes with water for at least **15 minutes**. Get medical attention for eyes.

NOTE

Procedure is same to install No. 1 or No. 2 check valve on roll, pitch, or yaw actuator. Installation of No. 1 valve is shown here.

1. Clean sealant from area of port (1). Use acetone (E20) and cloths (E135). Wear goggles and gloves (E186).
2. Install two packings (2 and 3) on check valve (4).
3. Install valve (4) in port (1). Torque valve to **17 inch-pounds**.

WARNING

Sealant (E336) can irritate skin and cause burns. Avoid contact with skin and clothing. In case of contact, immediately flush skin or eyes with water for at least **15 minutes**. Get medical attention for eyes.

4. Apply bead of sealant (E336) around valve (4). Wear goggles and gloves (E186).
5. Lockwire check valve (4) to relief valve (5). Use lockwire (E231).

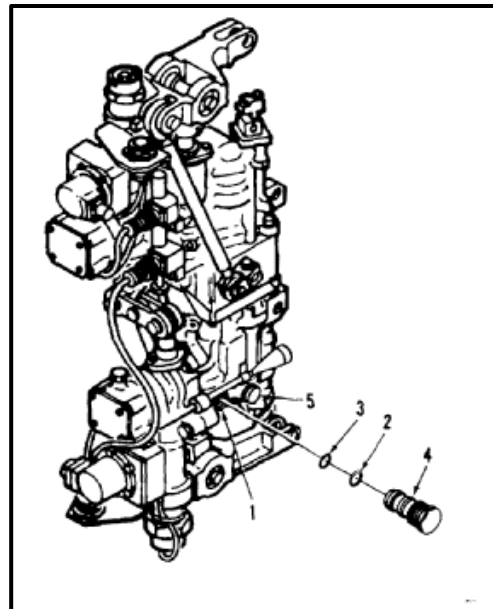
INSPECT
FOLLOW-ON MAINTENANCE:

Test ILCA (Task 7-98).

END OF TASK

INITIAL SETUP

Applicable Configurations:

All

Tools:

Hydraulic Repairer's Tool Kit, NSN 5180-00-323-4891
 Insertion/Extraction Tool, M83723/31-20

Materials:

Paper Tags (E264)
 Cloths (E135)
 Gloves (E186)

Personnel Required:

Aircraft Pneudraulics Repairer

Equipment Condition:

Off Helicopter Task

General Safety Instructions:**WARNING**

Hydraulic fluid (E199) is toxic. It can irritate skin and cause burns. Avoid inhaling. Use only with adequate ventilation. Avoid contact with skin, eyes, or clothing. In case of contact, immediately flush skin or eyes with water for at least **15 minutes**. Get medical attention for eyes.

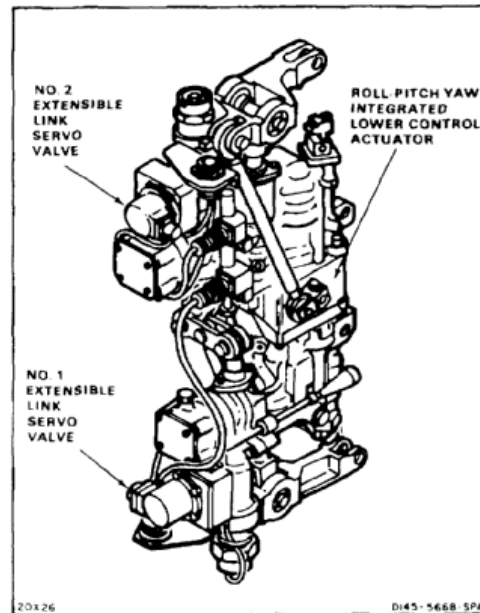

NOTE

Procedure is same to remove No. 1 or No. 2 roll, pitch, or yaw servo valve. Removal of No. 2 (top) valve is shown here.

1. Release cable (1) of servo valve (2) from cable (3). Cut ties.
2. Remove lockwire and two screws (4) from bracket (5).
3. Remove screw (6) from terminal lug (7) and bracket (5).
4. Remove lockwire and locknut (8) from connector/receptacle (9).

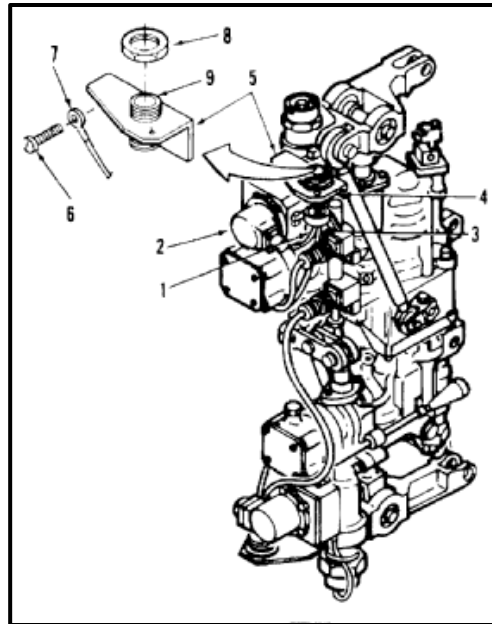

5. Remove connector/receptacle (9) from bracket (5) by unscrewing backshell (10) and sliding down cable (1).
6. Deleted.
7. Deleted.
8. Tag and disconnect three wires (11) of cable (1) from pins 8, 9, and 10 of connector/receptacle (9). Use insertion/extraction tool.
9. Remove lockwire from four screws (12).
10. Remove four screws (12) from servo valve block (13).
11. Remove servo valve (13) and four packings (14) from extensible link (15). Use cloths (E135) for spilled fluid. Use gloves (E186).

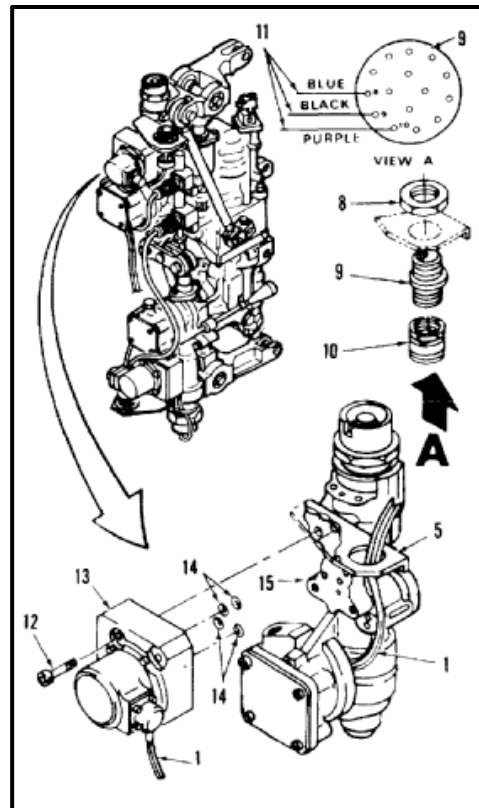
**FOLLOW-ON MAINTENANCE:**

None

END OF TASK

7-374

INITIAL SET UP

Applicable Configurations:

All

Tools:

- Hydraulic Repairer's Tool Kit, NSN 5180-00-323-4891
- Insertion/Extraction Tool, M83723/31-20
- Torque Wrench, 0 to 50 Inch-Pounds

Materials:

- Lockwire (E227)
- Lockwire (E230)
- Strap (E374)
- Twine (E433)

Parts:

- Preformed Packings

Personnel Required:

- Aircraft Pneudraulics Repairer
- Inspector

References:

- TM 55-1520-240-23P

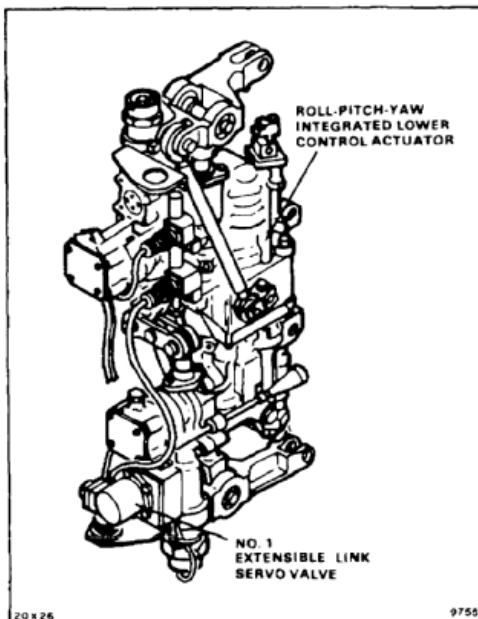

NOTE

Procedure is same to install No. 1 or No. 2 roll, pitch, or yaw servo valve. Installation of No. 2 (top) valve is shown here.

1. Install four packings (1) in valve block (2).

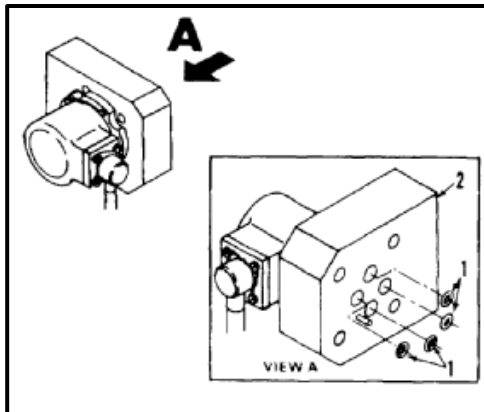

NOTE

Servo valve (2) has an aligning pin on its base. Be careful that pin seats in its mating hole (3) in manifold (4).

2. Position servo valve (2) on manifold (4) with adapter (5) to the right. Install four screws (6). Torque screws to **30 inch-pounds** and lockwire (E230).
3. Thread cable (8) through backshell (9) and connect blue wire (7) of cable (8) to pin No. 8 of connector/receptacle (12). Use insertion/extraction tool. Remove tag.
4. Connect black wire (10) to pin No. 9. Use insertion/extraction tool. Remove tag.
5. Connect purple wire (11) to pin No. 10. Use insertion/extraction tool.
6. Position connector/receptacle (12) in bracket (13) from underside. Install locknut (14) on connector/receptacle. Use lockwire (E227).
7. Install backshell (9) on connector/receptacle (12).
8. Install bracket (13) on manifold (4). Use screws (15 and 16), ground connector by installing screw with beveled head (15) through terminal lug (17).
9. Torque screws (15 and 16) to **30 inch-pounds** and lockwire (E230).
10. Tie cable (8) to cables (18 and 19). Use twine (E433).

INSPECT**FOLLOW-ON MAINTENANCE:**

Test extensible link (Task 7-97).

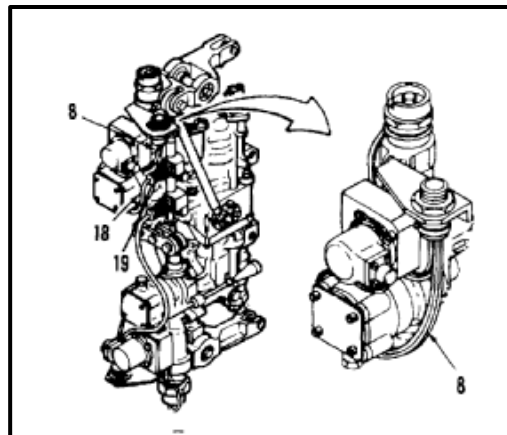
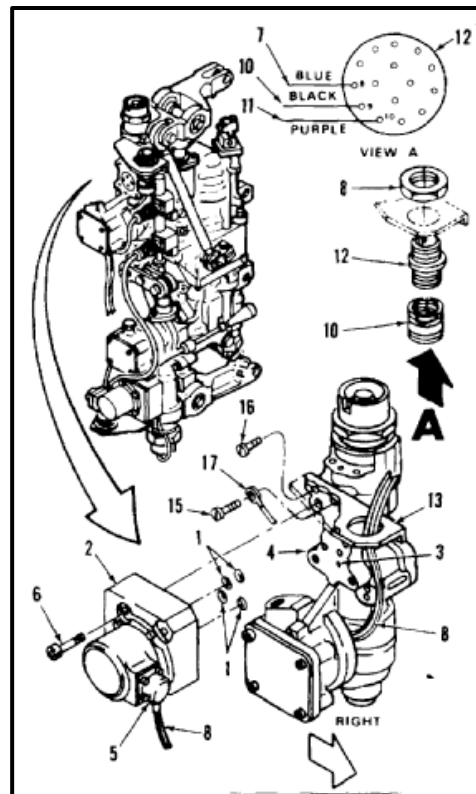

END OF TASK

INITIAL SETUP

Applicable Configurations:

All

Tools:

- Integrated Lower Controls Actuator Bench Test Set 145GS278-1
- Power Source, 115 Volt, 60 Hz AC
- Hydraulic Test Stand D5 or Equivalent
- Aircraft Mechanic's Tool Kit, NSN 5180-00-323-4692
- Safety Ground Cable
- Stopwatch

Materials:

- Acetone (E20)
- Cloths (E135)
- Lockwire (E231)
- Screws NAS1351-4-4H14P
- Gloves (E186)

Parts:

- Preformed Packings
- Screws (3)

Personnel Required:

- Avionic Navigation and Flight Control Equipment Repairer
- Aircraft Pneudraulics Repairer
- Inspector

References:

TM 55-1520-240-23P

Equipment Condition:

- Off Helicopter Task
- Integrated Lower Control
- Actuator Bench Test Set Prepared for Use (TM 55-4920-428-13)

General Safety Instructions:

WARNING

Hydraulic fluid (E199) is toxic. It can irritate skin and cause burns. Avoid inhaling. Use only with adequate ventilation. Avoid contact with skin, eyes, or clothing. In case of contact, immediately flush skin or eyes with water for at least **15 minutes**. Get medical attention for eyes.

WARNING

Wear face shields throughout these tests. Hydraulic fluid ejected under pressure can cause injury to personnel. Hydraulic fluid sprayed into the air is a fire hazard.

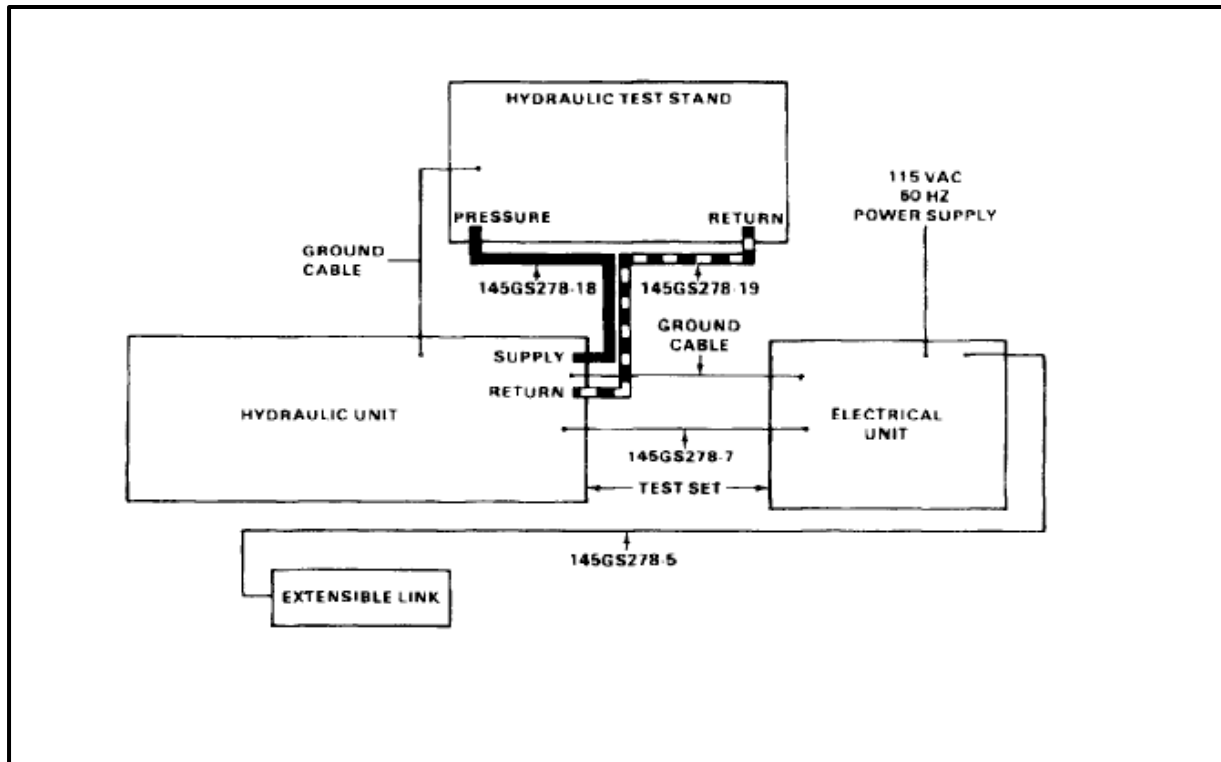

PRELIMINARY PROCEDURE

NOTE

Electrical unit AFCS 2 switches and hydraulic unit RETURN SYS 2, AFCS PRESS SYS 2, and ILCA PRESS SYS 1 and SYS 2 valves are not used in these procedures.

Pitch, roll and yaw are tested as spare links.

After test set has been in operation, HIGH PRESS gage and LOW PRESS gage will not return to **0 psi**, when shutoff and regulator valves are closed and relief valves are pressed. The HIGH PRESS gage may read **20 to 35 psi**. The LOW PRESS gage may read **25 to 60 psi**. This is normal.

1. Remove screw (1) from post snug (2) of dial indicator (3). Remove indicator.

2. Stow dial indicator (3) in cover.
3. Remove two screws (4) from AFCS manifold (5) and remove manifold.



Do not damage seals. Otherwise component will malfunction.

4. Position extensible link manifold (5) on three check valves (6) on left side of actuator manifold (7). Seat manifold on valves (7). Seat manifold on valves.

NOTE

Caps must be installed on check valves not in use.

5. Install two screws (4).
6. Position extensible link (8), piston (9) to left on manifold (5), install three screws (10).

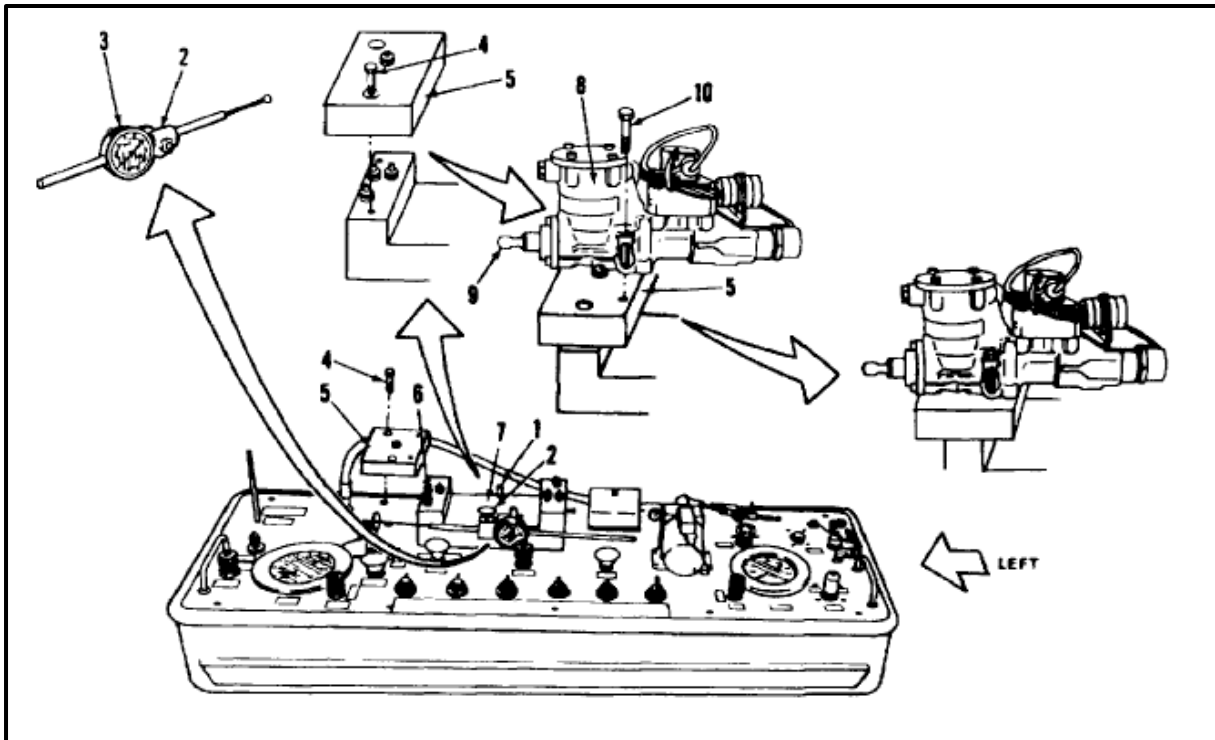

WARNING

Cover is spring-loaded. Remove with caution. Otherwise personal injury can occur.

WARNING

Acetone (E20) is flammable and toxic. It can irritate skin and cause burns. Use only in well-ventilated area, away from heat and open flame. In case of contact, immediately flush skin or eyes with plenty of water for at least **15 minutes**. Get medical attention for eyes.

7. Remove two screws (11) and wing nuts (12) from adapter (5).
8. Remove lockwire from four screws (13).
9. Remove two opposing screws (13).
10. Install two screws (11) with wing nuts (12). Tighten wing nuts against cover (14).
11. Remove remaining two screws (13).
12. Loosen two wing nuts (12). Remove two screws (11).
13. Tag and remove cover (14) and packing (15). Set cover aside.
14. Clean authority cover 145GS278-12 (16) with acetone (E20). Use gloves (E186).
15. Position cover (16) and packing (15) on extensible link (8). Install two screws (13) with wing nuts (12). Tighten wing nuts until cover seats.
16. Install two screws (13).
17. Remove two screws (11) with wing nuts (12).
18. Install remaining two screws (13).
19. Connect No. 1 AFCS cable 145GS278-5 (17) between AFCS 1 receptacle (18) and extensible link receptacle (19).

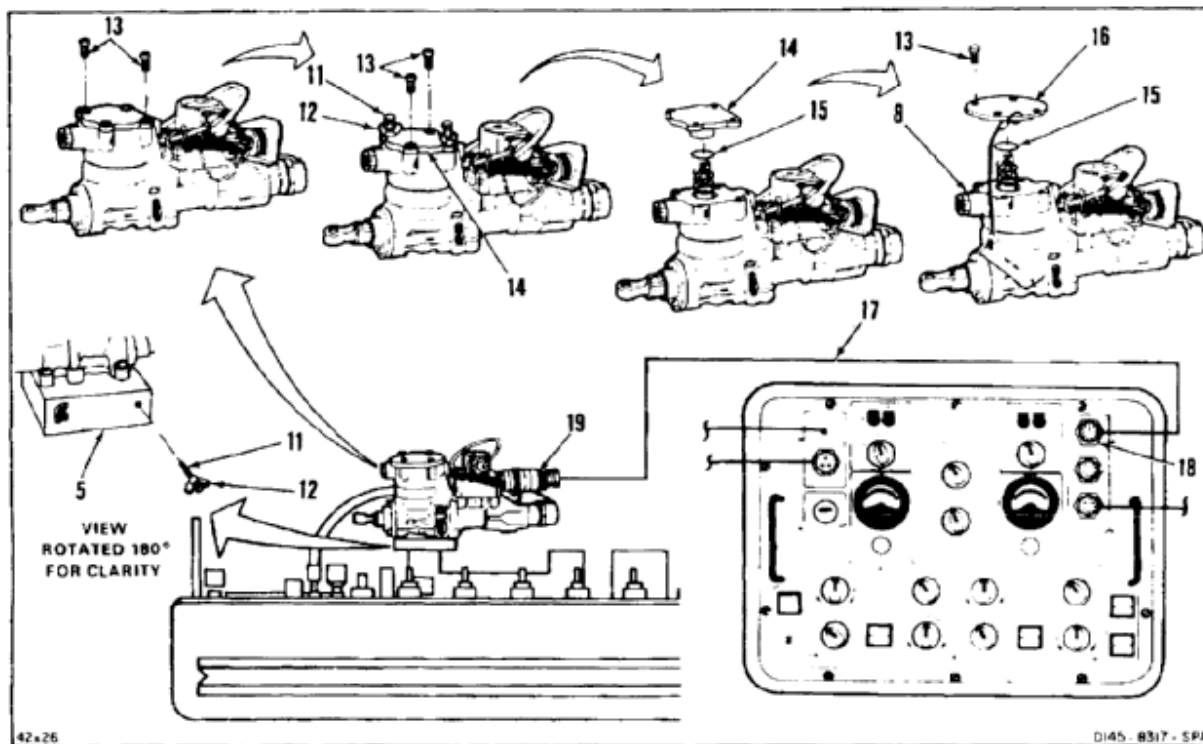

20. Set electrical unit controls as follows:

INITIAL SETTINGS OF ELECTRICAL UNIT CONTROLS

NOTE

AFCS 2 controls are not used. They should, however, be kept at initial settings.

SWITCH IDENTIFICATION	POSITION REQUIRED
Power switch (20)	ON
Both FUNCTION SELECT switches (21 and 22)	CLSD LOOP
Both FEEDBACK SELECT switches (23 and 24)	SELF
Both VALVE CONTROLS (25 and 26)	NULL
Both SQ WAVE controls (27 and 28)	MINIMUM
Both LINK TEST switches (29 and 30)	VALVE
Both EXTERNAL METER SELECT switches (31 and 32)	SELF FDBK
BITE switch (33)	-20V
SYSTEM SELECT switch (34)	AFCS 1
SOLENOID SHUTOFF switch (35)	CLOSED
CYCLE MOTOR switch (36)	OFF
LAMP TEST switch (37)	Released (out)

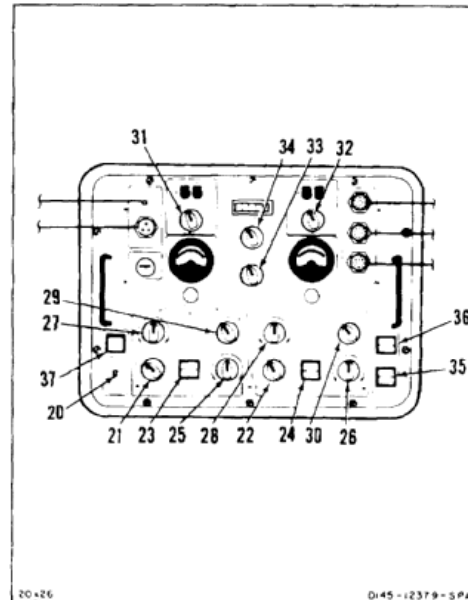

21. Set hydraulic unit controls as follows:

INITIAL SETTINGS OF HYDRAULIC UNIT CONTROLS

NOTE

RETURN SYS 2 valve, AFCS PRESS SYS 2 valve, and ILCA PRESS SYS 1 and SYS 2 valves are not used in these tests. They should, however, be kept at initial settings.

VALVE IDENTIFICATION	POSITION REQUIRED
CAUTION	
RETURN SHUTOFF VALVE shall be OPEN unless otherwise specified in a test.	
RETURN SHUTOFF valve (38)	Full OPEN
CASE VENT LINE PRESS valve (39)	Full CLOSE
RETURN BACK PRESS valve (40)	Full CLOSE
LOW PRESS REGULATOR valve (41)	Full DECREASE
Both RETURN valves (42 and 43)	OFF
Both AFCS PRESS valves (44 and 45)	OFF
Both ILCA PRESS valves (46 and 47)	OFF
HIGH PRESS SHUTOFF VALVE (48)	Full CLOSE
HIGH PRESS REGULATOR valve (49)	Full DECREASE
SOLENOID valve (50)	CLOSED (in)

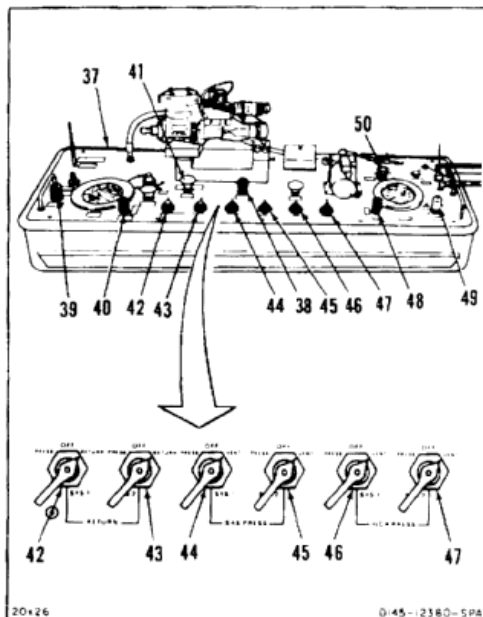

22. Apply test stand pressure of **1500 psi**.

23. Set electrical and hydraulic unit controls as follows:
 - a. Check RETURN SHUTOFF valve (38) is OPEN.
 - b. SOLENOID valve (50) is OPENED.
 - c. SOLENOID shutoff switch (35) to OPEN.
 - d. RETURN SYS 1 valve (42) to RETURN.
 - e. AFCS PRESS SYS 1 valve (44) to PRESS.
 - f. Slowly turn HIGH PRESS REGULATOR valve (49) towards INCREASE until HIGH PRESS gage (51) indicates **100 to 150 psi**.
24. Remove lockwire from bleed cap (52).
25. Slowly turn HIGH PRESS SHUTOFF valve (48).
26. Loosen bleed cap (52). Allow fluid to flow until air free. Use cloths (E135) for spilled fluid to control fluid flow. Use gloves (E186).
27. Close HIGH PRESS SHUTOFF valve (48).

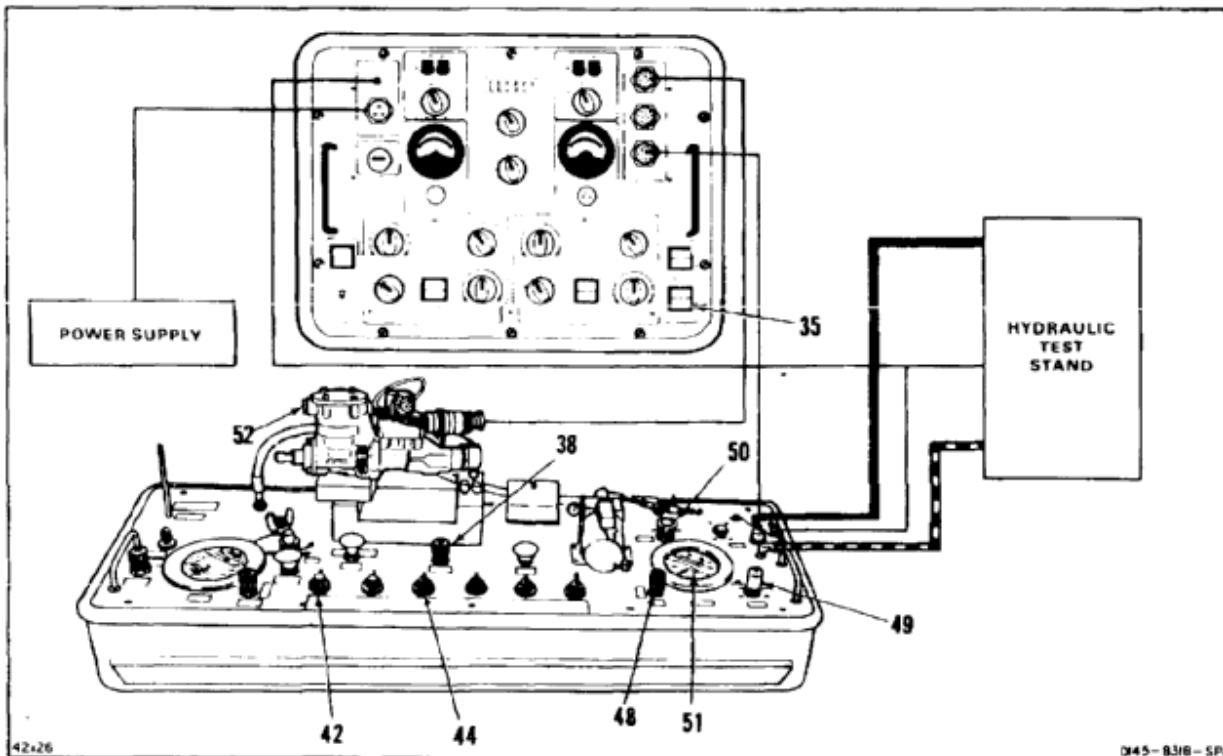

28. Tighten bleed port (52). Use cloths (E135) for spilled fluid.
29. Set LINK TEST switch (29) to SELF FDBK.
30. Slowly turn HIGH PRESS REGULATOR valve (49) towards INCREASE until HIGH PRESS gage (51) indicates **750 psi**.
31. Open HIGH PRESS SHUTOFF valve (48).
32. Turn VALVE CONTROL (25) to RETRACT, then NULL, then EXTEND, and then back to NULL **three times**.
33. Set electrical and hydraulic unit controls as follows:
 - a. Turn HIGH PRESS REGULATOR valve (49) to full DECREASE.
 - b. HIGH PRESS SHUTOFF valve (48) to CLOSE.
 - c. SOLENOID valve (50) to CLOSED.
 - d. SOLENOID SHUTOFF switch (35) to CLOSE.
 - e. AFCS PRESS SYS 1 valve (44) to VENT.
 - f. Push and hold HIGH PRESS RELIEF valve (53) and LOW PRESS RELIEF valve (54) for **15 seconds**.
 - g. AFCS PRESS SYS 1 valve (44) to OFF.
 - h. RETURN SYS 1 valve (42) to OFF.
34. Set LINK TEST switch (29) to VALVE.
35. Lockwire bleed port (52). Use lockwire (E231).

INSPECT**END OF PRELIMINARY PROCEDURES****FOLLOW-ON MAINTENANCE:**

Perform test 1 thru 9 as required.

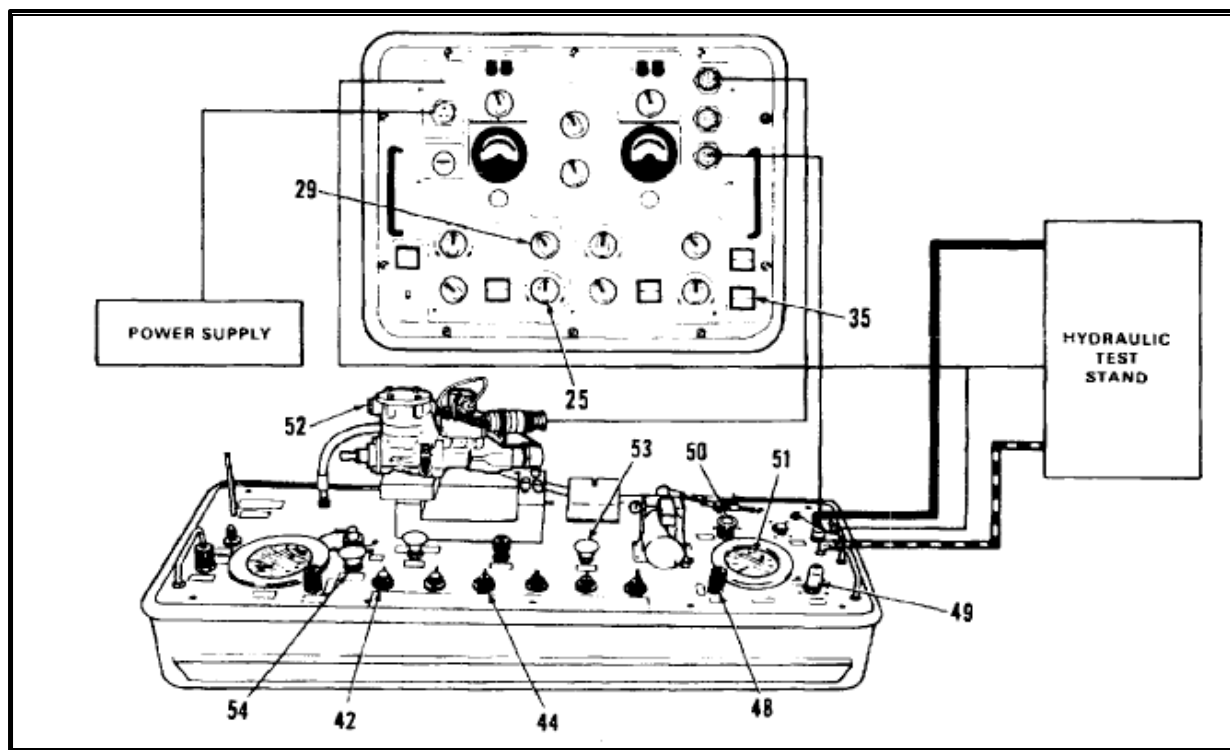

TEST 1**TRANSDUCER NULL TEST**

36. Perform steps 1 thru 35. Check initial control and valve settings in steps 20 and 21.
37. Set LINK TEST switch (29) to SELF FDBK.
38. Read DVM (55). Reading shall be **0.018 or less**. Record reading. If reading is more than **0.0180**, adjust transducer (Task 7-101).

39. Set LINK TEST switch (29) to VALVE.
40. If no further testing is required, perform normal shutdown (TM 55-4920-428-13).

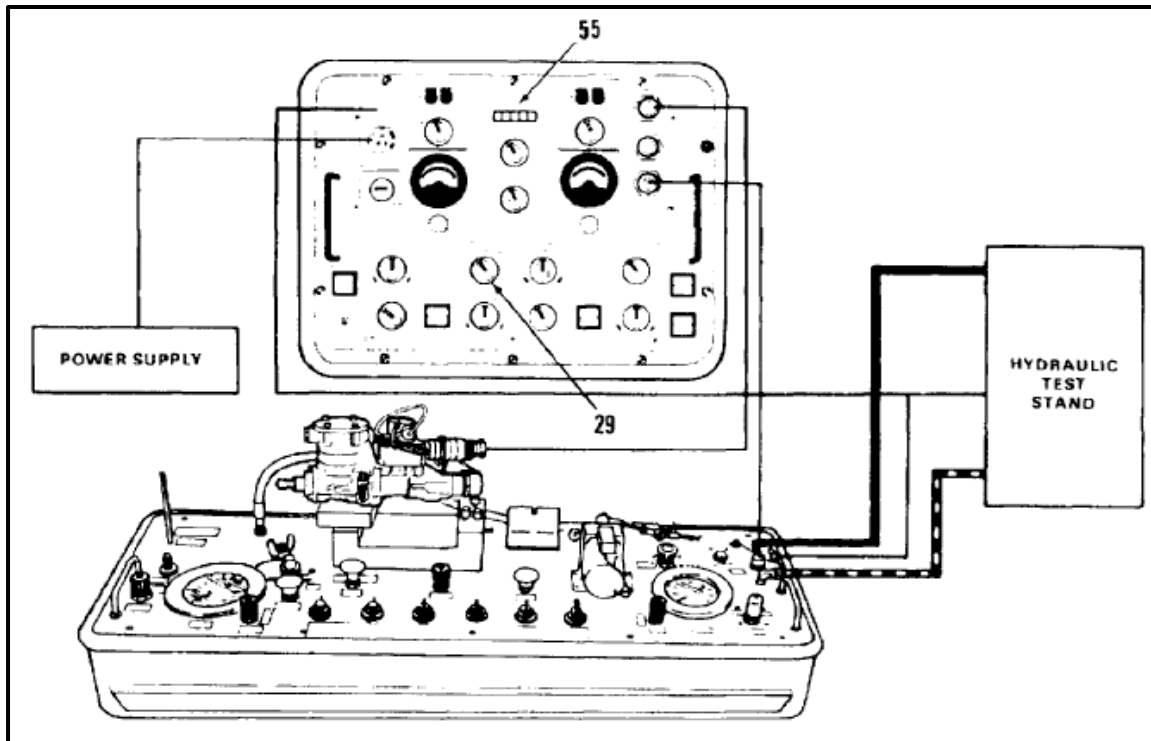
END OF TRANSDUCER NULL TEST

TEST 2
MANUAL CYCLING TEST

41. Perform steps 1 thru 35. Check initial control and valve settings in steps 20 and 21.
42. Set electrical and hydraulic unit controls as follows:
 - a. Check RETURN SHUTOFF valve (38) is OPEN.
 - b. SOLENOID valve (50) to OPENED.
 - c. SOLENOID SHUTOFF switch (35) to OPEN.
 - d. RETURN SYS 1 valve (42) to RETURN.
 - e. AFCS PRESS SYS 1 valve (44) to PRESS.
- f. Slowly turn HIGH PRESS REGULATOR valve (49) towards INCREASE until HIGH PRESS gage (51) indicates **600 psi**.
- g. LINK TEST switch (29) to SELF FDBK.
- h. Slowly turn HIGH PRESS SHUTOFF valve (48) **one turn** towards OPEN.
43. Turn VALVE CONTROL (25) to RETRACT, then NULL, then EXTEND and then back to NULL **three times**. There shall be no binding of extensible link.
44. Slowly turn HIGH PRESS REGULATOR valve (49) towards INCREASE until HIGH PRESS gage (51) indicates **1500 psi**.

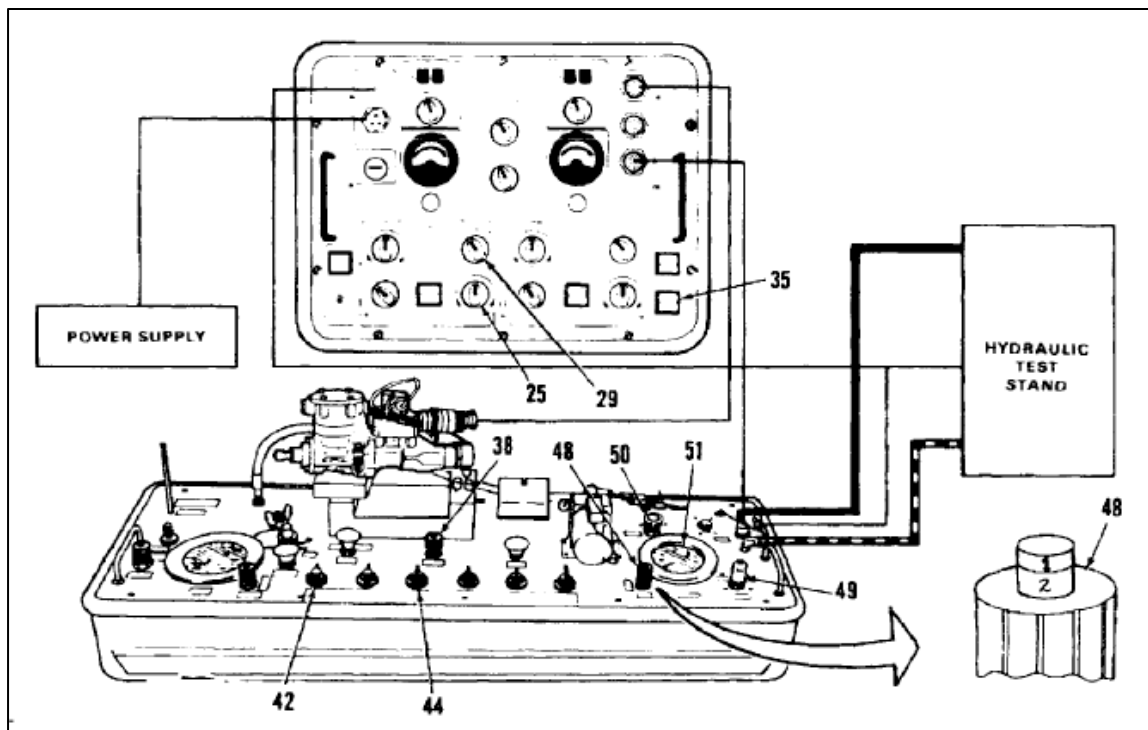

45. Slowly turn HIGH PRESS SHUTOFF valve (48) to full OPEN.
 46. Turn VALVE CONTROL (25) from RETRACT, then NULL, then EXTEND and then back to NULL **three times**. There shall be no binding of piston (9).
 47. Set FUNCTION SELECT switch (21) to SQ WAVE.
 48. Turn SQ WAVE control (27) towards MAX until piston (9) moves about **5/16 inch** total stroke. Allow piston to move for **15 minutes**; then run for **50 strokes**. Check for leaks at piston. Leaks shall not exceed **1 drop in 50 strokes**.

NOTE

Stroke rate can vary with temperature. Count the strokes.
 49. Set FUNCTION SELECT switch (21) to BALANCE. Set SQ WAVE control (27) to MIN. Piston (9) shall stop.
 50. Allow piston (9) to sit for **5 minutes**. Check for leaks. There shall be no leaks.
 51. Set electrical and hydraulic unit controls as follows:
 - a. HIGH PRESS REGULATOR valve (49) to DECREASE.
 - b. HIGH PRESS SHUTOFF valve (48) to CLOSE.
 - c. SOLENOID SHUTOFF switch (35) to CLOSED.
 - d. SOLENOID valve (50) to CLOSED.
 - e. AFCS PRESS SYS 1 valve (44) to VENT.
 - f. Push and hold HIGH PRESS RELIEF valve (53) and LOW PRESS RELIEF valve (54) for **15 seconds**.
 - g. AFCS PRESS SYS 1 valve (44) to OFF.
 - h. RETURN SYS 1 valve (42) to OFF.
 52. Set electrical unit controls as follows:
 - a. LINK TEST switch (29) to VALVE.
 - b. FUNCTION SELECT switch (21) to CLSD LOOP.
 53. If no further testing is required, perform normal shutdown (TM 55-4920-428-13).
- END OF MANUAL CYCLING TEST**

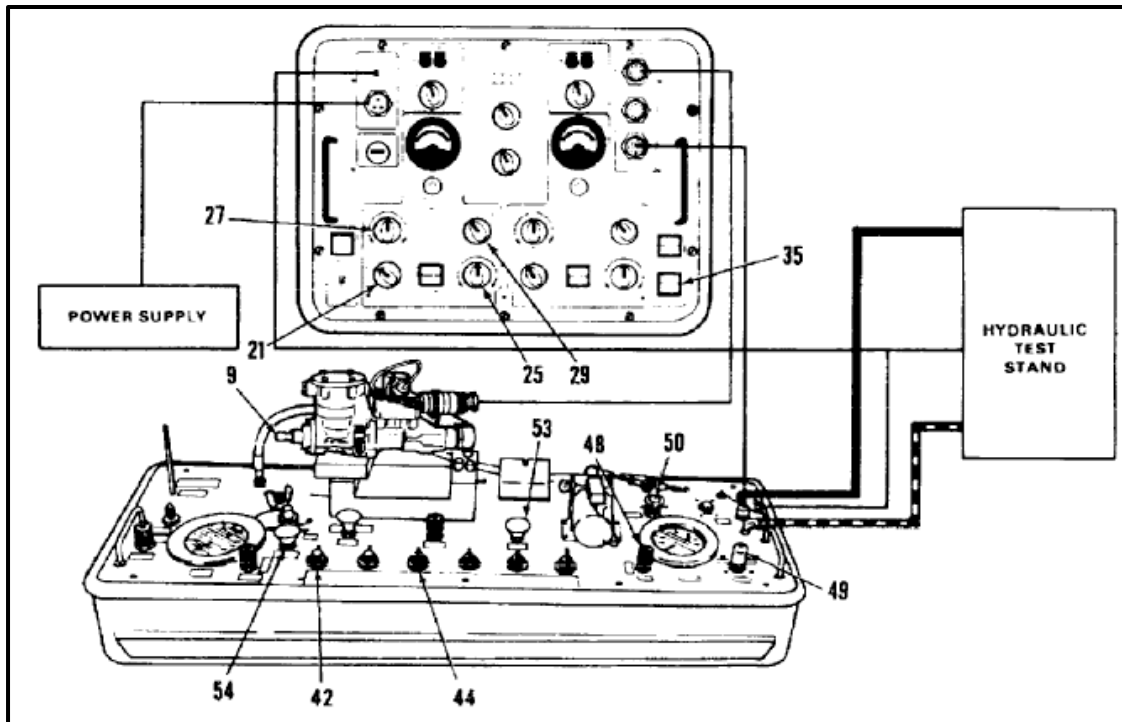

TEST 3

CYLINDER STROKE TEST

54. Perform steps 1 thru 35. Check initial control and valve settings in steps 20 and 21.
55. Remove dial indicator (3) from cover.
56. Install dial indicator (3) on post (57). Set anvil of indicator against piston (9). Adjust indicator to **1 inch**.
57. SET LINK TEST switch (29) to SELF FDBK.
58. Set electrical and hydraulic unit controls as follows:
- Check RETURN SHUTOFF VALVE (38) is OPEN.
 - SOLENOID valve (50) to OPENED.
 - SOLENOID SHUTOFF switch (35) to OPEN.
- RETURN SYS 1 valve (42) to RETURN.
 - AFCS PRESS SYS 1 valve (44) to PRESS.
 - Slowly turn HIGH PRESSURE REGULATOR valve (49) towards INCREASE until HIGH PRESS gage (51) indicates **1500 psi**.
 - Slowly turn HIGH PRESS SHUTOFF valve (48) to OPEN.
59. Turn VALVE CONTROL (25) to EXTEND, Piston (9) shall extend. Read and record indication (3). Subtract **1.000 inch** from reading. AFCS NULL METER (57.1) shall move to the right. Travel shall be **0.310 to 0.370 inch**.
- Set FUNCTION SELECT switch (21) to HARDOVER EXTEND. Record reading on DVM (55). Reading shall be **1.50 to 1.91**.
 - Set FUNCTION SELECT switch (21) to CLSD LOOP.

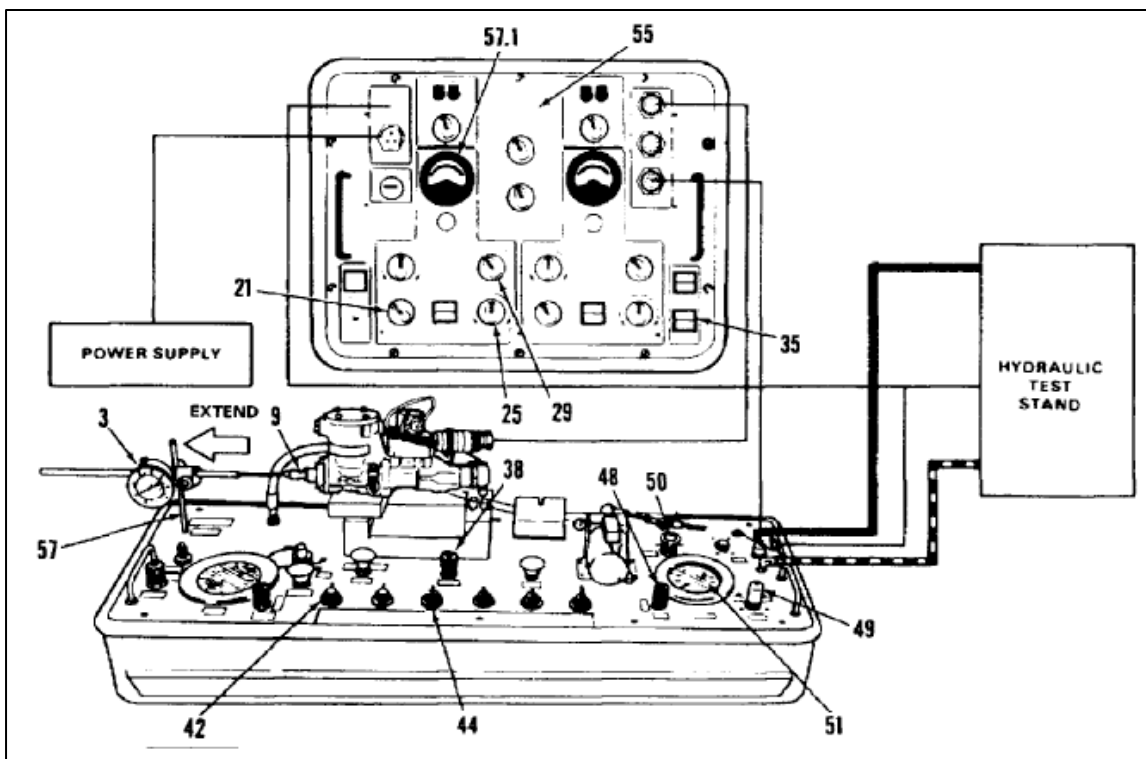

- 60. Slowly turn VALVE CONTROL (25) to RETRACT. Piston (9) shall retract. Read and record indication on dial indicator (3). Subtract reading from **1.00 inch**. Travel shall be **0.310 to 0.370 inch**. AFCS NULL METER (57.1) shall move to left.
 - 60.1. Set FUNCTION CONTROL switch (21) to HARDOVER RETRACT. Record reading on DVM (55). Reading shall be **1.50 to 1.91**.
 - 61. Set VALVE CONTROL (25) to NULL.
 - 62. Set electrical and hydraulic unit controls as follows:
 - a. HIGH PRESS REGULATOR valve (49) to DECREASE.
 - b. HIGH PRESS SHUTOFF valve (48) to CLOSE.
 - c. SOLENOID SHUTOFF switch (35) to CLOSED.
 - d. SOLENOID valve (50) to CLOSED.
 - e. AFCS PRESS SYS 1 valve (44) to VENT.
 - f. Push and hold HIGH PRESS RELIEF VALVE (53) and LOW PRESS RELIEF valve (54) for **15 seconds**.
 - g. AFCS PRESS SYS 1 valve (44) to OFF.
 - h. RETURN SYS 1 valve (42) to OFF.
 - 63. Set LINK TEST switch (29) to VALVE.
 - 64. If not needed for further testing, remove dial indicator (3). Stow in cover.
- NOTE**
Indicator is used in Test 4.
- 65. If no further testing is required, perform normal shutdown (TM 55-4920-428-13).
- END OF CYLINDER STROKE TEST**

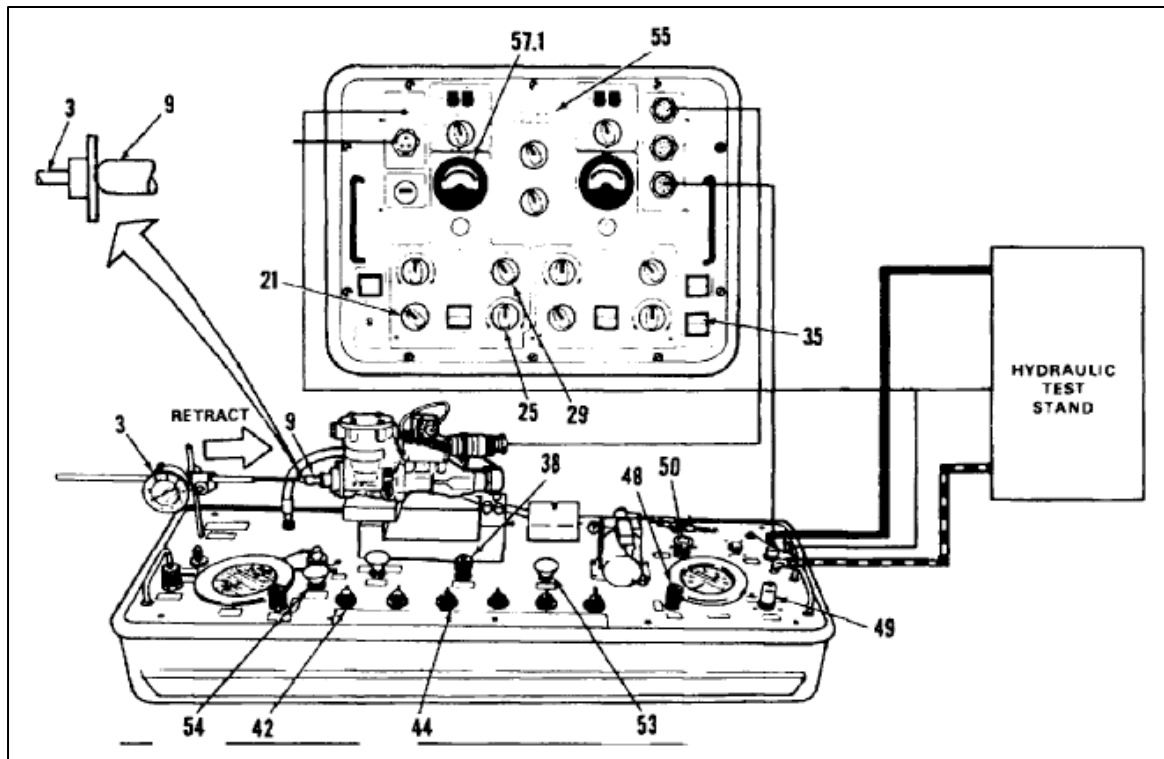

TEST 4

STABILITY TEST

66. Perform steps 1 thru 35. Check initial control and valve settings in steps 20 and 21.
67. SET LINK TEST switch (29) to SELF FDBK.
68. Set FUNCTION SELECT switch (21) to BALANCE.
69. Install dial indicator (3) on post (57). Position anvil of indicator against piston (9). Adjust indicator to **1 inch**.
70. Set electrical and hydraulic unit controls as follows:
 - a. Check RETURN SHUTOFF valve (38) is OPEN.
 - b. SOLENOID valve (50) to OPENED.
 - c. SOLENOID SHUTOFF switch (35) to OPEN.
 - d. RETURN SYS 1 valve (42) to RETURN.
 - e. AFCS PRESS SYS 1 valve (44) to PRESS.
 - f. Slowly turn HIGH PRESS REGULATOR valve (49) toward INCREASE until HIGH PRESS gage (51) indicates **1500 psi**.
 - g. Slowly turn HIGH PRESS SHUTOFF valve (48) to OPEN.
71. Set FUNCTION SELECT switch (21) to HARD OVER RETRACT then BALANCE. Check dial indicator (3) for piston (9) movement. There shall be no movement and indicator shall indicate **1 inch**. An overshoot of **0.002 to 0.005 inch** is allowed, but piston shall stop within **1 second**.

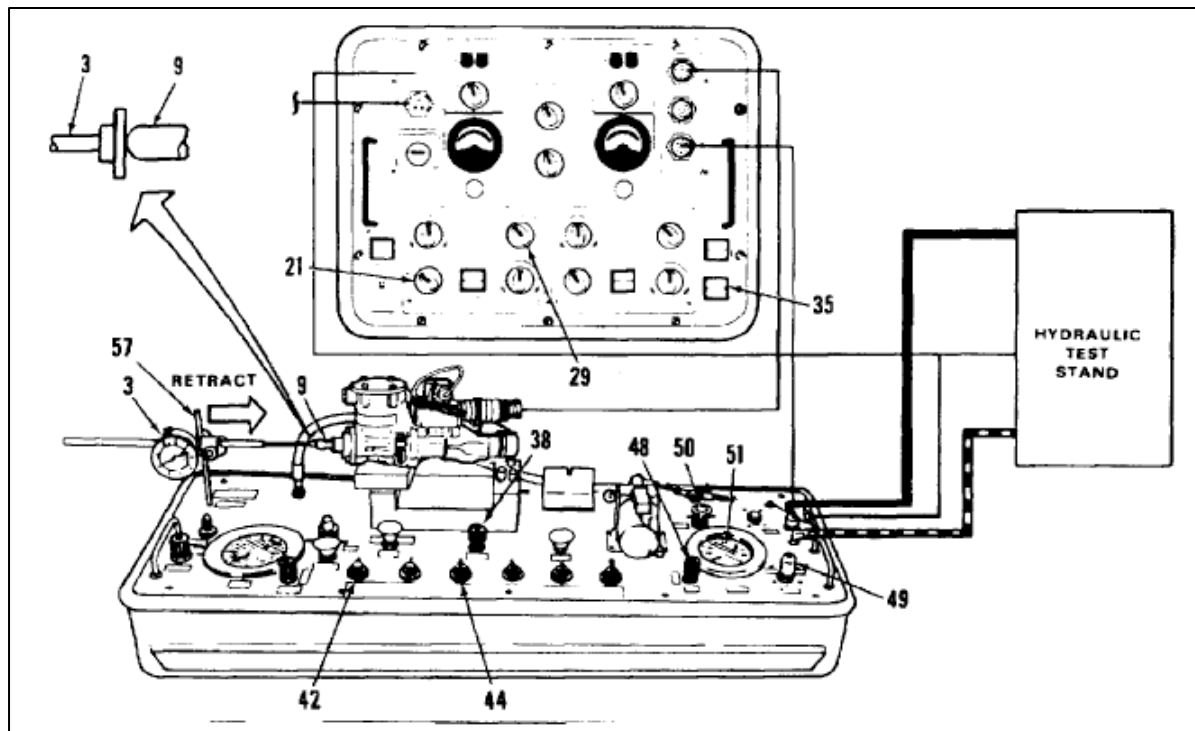

72. Set FUNCTION SELECT switch (21) to HARD OVER EXTEND then BALANCE. Check dial indicator (3) for piston (9) movement. There shall be no movement and indicator shall indicate **1 inch**. An overshoot of **0.002 to 0.005 inch** is allowed, but piston shall stop within **1 second**.
73. Set FUNCTION SELECT switch (21) to CLSD LOOP.
74. Set electrical and hydraulic unit controls as follows:
 - a. HIGH PRESS REGULATOR valve (49) to DECREASE.
 - b. HIGH PRESS SHUTOFF valve (48) to CLOSE.
 - c. SOLENOID SHUTOFF switch (35) to CLOSED.
 - d. SOLENOID valve (50) to CLOSED.
 - e. AFCS PRESS SYS 1 valve (44) to VENT.
 - f. Push and hold HIGH PRESS RELIEF valve (53) and LOW PRESS RELIEF valve (54) for **15 seconds**.
 - g. AFCS PRESS SYS 1 valve (44) to OFF.
 - h. RETURN SYS 1 valve (42) to OFF.
75. Set LINK TEST switch (29) to VALVE.
76. Remove dial indicator (3). Stow in cover.
77. If no further testing is required, perform normal shutdown (TM 55-4920-428-13).

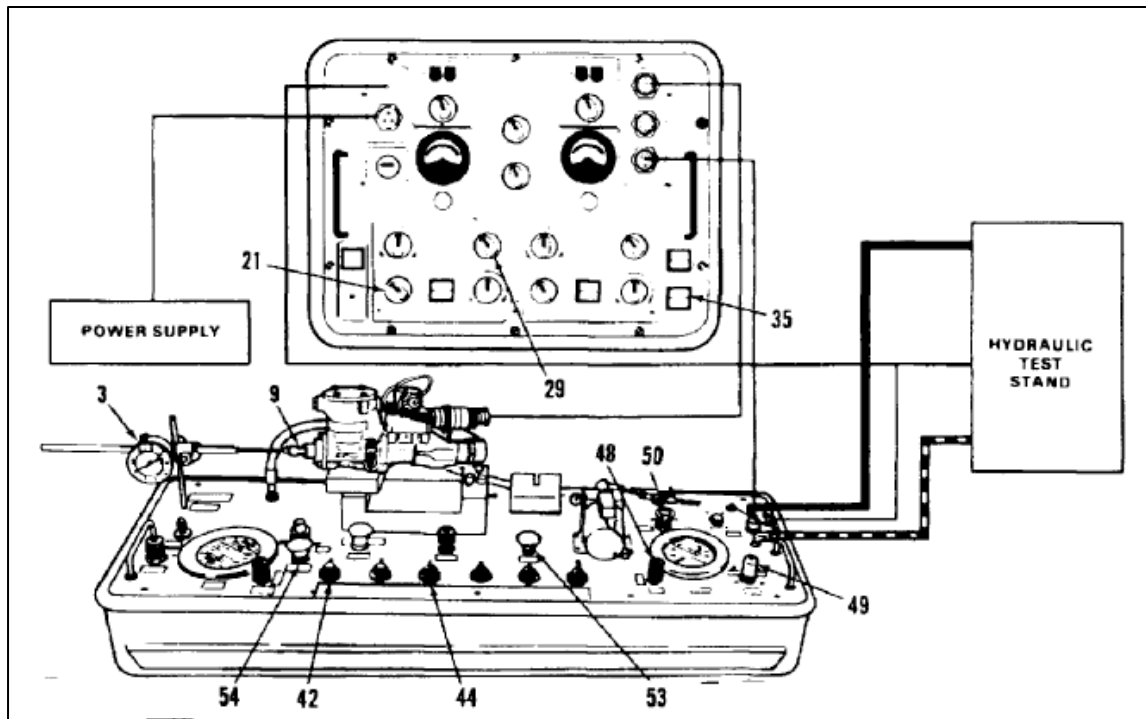
END OF STABILITY TEST

TEST 5

PROOF PRESSURE TEST

78. Perform steps 1 thru 35. Check initial control and valve settings in steps 20 and 21.
79. Adjust test stand pressure to **2600 psi**.
80. SET LINK TEST switch (29) to SELF FDBK.
81. Set electrical and hydraulic unit controls as follows:
- Check RETURN SHUTOFF valve (38) is OPEN.
 - SOLENOID valve (50) to OPENED.
 - SOLENOID SHUTOFF switch (35) to OPEN.
 - RETURN SYS 1 valve (42) to RETURN.
 - AFCS PRESS SYS 1 valve (44) to PRESS.
 - Slowly turn HIGH PRESS REGULATOR valve (49) towards INCREASE until HIGH PRESS gage (51) indicates **2250 psi**.
 - Slowly turn HIGH PRESS SHUTOFF valve (48) to OPEN.
82. Set FUNCTION SELECT switch (21) to HARD OVER EXTEND. Hold for **5 minutes**. Check for external leaks. There shall be no leaks.
83. Set FUNCTION SELECT switch (21) to HARD OVER RETRACT. Hold for **5 minutes**. Check for external leaks. There shall be no leaks.
84. Set FUNCTION SELECT switch (21) to CLSD LOOP.

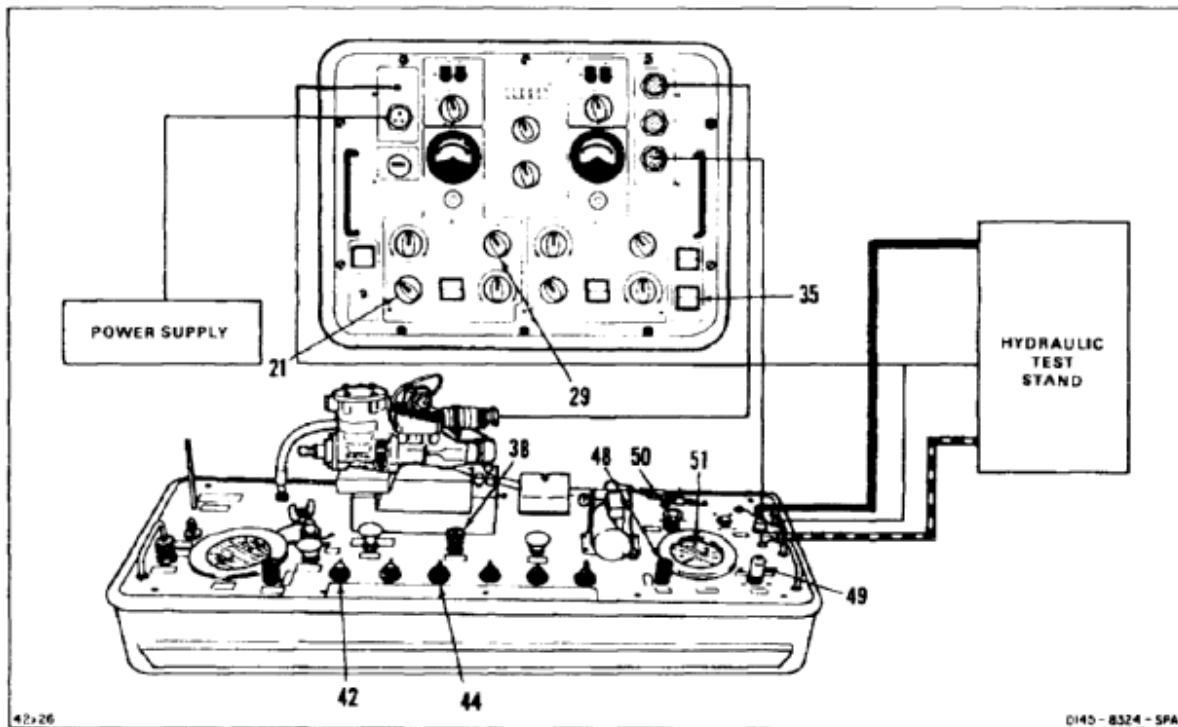

- 85. Check for pressure damage. There shall be no visual damage.
- 86. Set electrical and hydraulic unit controls as follows:
 - a. HIGH PRESS REGULATOR valve (49) to DECREASE.
 - b. HIGH PRESS SHUTOFF valve (48) to CLOSE.
 - c. SOLENOID SHUTOFF switch (35) to CLOSED.
 - d. SOLENOID valve (50) to CLOSED.
 - e. AFCS PRESS SYS 1 valve (44) to VENT.
 - f. Push and hold HIGH PRESS RELIEF valve (53) and LOW PRESS RELIEF valve (54) for **15 seconds**.
 - g. AFCS PRESS SYS 1 valve (44) to OFF.
 - h. RETURN SYS 1 valve (42) to OFF.
- 87. Set LINK TEST switch (29) to VALVE.
- 88. Reduce test stand pressure to **1500 psi**.
- 89. If no further testing is required, perform normal shutdown (TM 55-4920-428-13).

END OF PROOF PRESSURE TEST

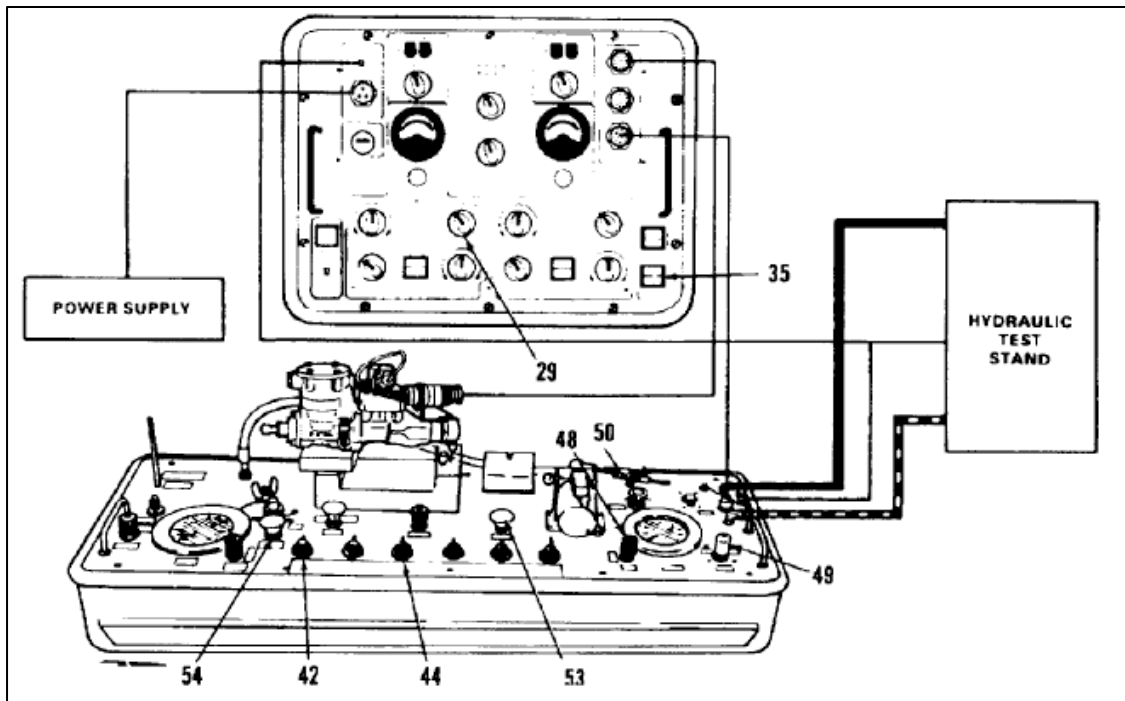

TEST 6

RETURN PROOF PRESSURE TEST

90. Perform steps 1 thru 35. Check initial control and valve settings in steps 20 and 21.
91. Set LINK TEST switch (29) to SELF FDBK.
92. Set electrical and hydraulic unit controls as follows:
 - a. Check RETURN SHUTOFF valve (38) is OPEN.
 - b. SOLENOID valve (50) to OPENED.
 - c. SOLENOID SHUTOFF switch (35) to OPEN.
 - d. RETURN SYS 1 valve (42) to RETURN.
 - e. AFCS PRESS SYS 1 valve (44) to PRESS.
- f. Slowly turn HIGH PRESS REGULATOR valve (49) toward INCREASE until HIGH PRESS gage (51) indicates **1000 psi**.
- g. Slowly turn HIGH PRESS SHUTOFF valve (48) to OPEN.
93. Slowly turn RETURN SHUTOFF valve (38) toward CLOSE. At the same time, keep turning VALVE CONTROL (25) between EXTEND and RETRACT. Piston (9) will stop when RETURN SHUTOFF valve is fully closed.
94. Allow piston (9) to remain in this condition for **5 minutes**; then turn RETURN SHUTOFF valve (38) to OPEN.
95. Set HIGH PRESS SHUTOFF valve (48) to CLOSE.

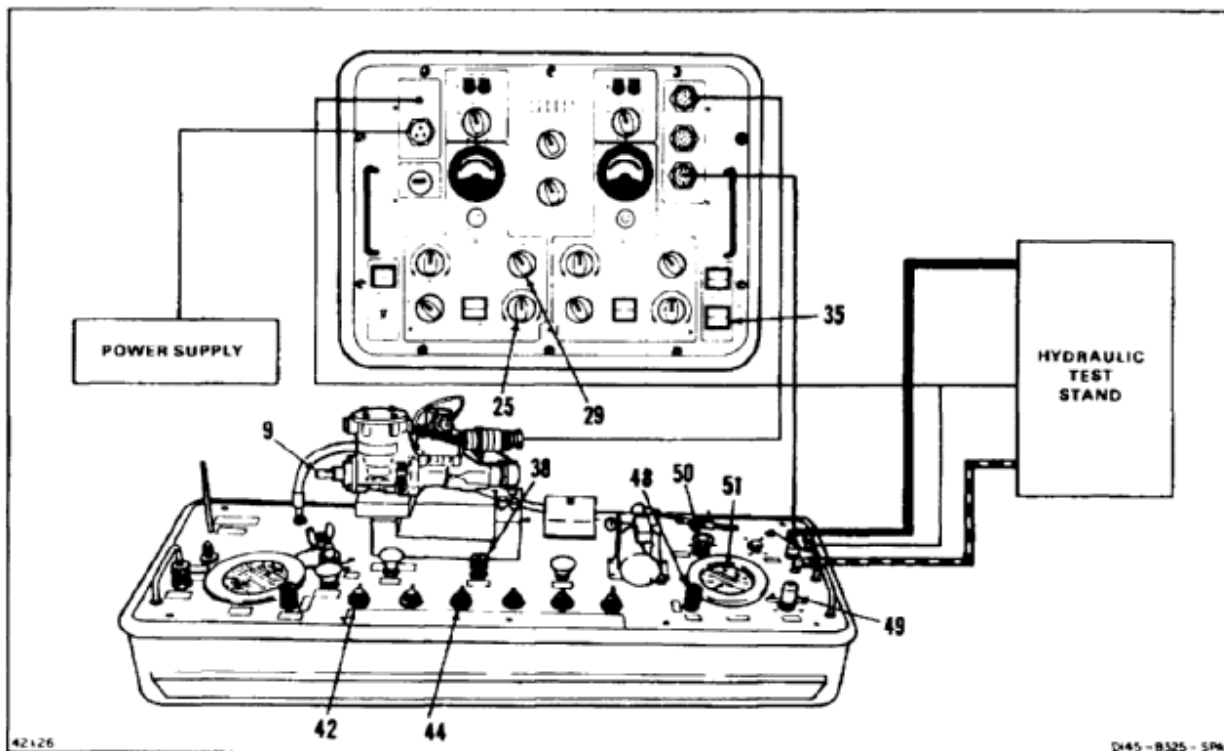

- 96. Turn HIGH PRESSURE REGULATOR valve (49) to DECREASE.
- 97. Set SOLENOID valve (50) to CLOSED.
- 98. Set SOLENOID SHUTOFF switch (35) to CLOSE.
- 99. Check for external leaks and pressure damage. There shall be no leaks or visual damage.
- 100. Set hydraulic unit controls as follows:
 - a. AFCS PRESS SYS 1 valve (44) to VENT.
 - b. Push and hold HIGH PRESS RELIEF VALVE (53) and LOW PRESS RELIEF valve (54) for **15 seconds**.
- c. AFCS PRESS SYS 1 valve (44) to OFF.
- d. RETURN SYS 1 valve (42) to OFF.
- 101. Set electrical unit controls as follows:
 - a. VALVE CONTROL (25) to NULL.
 - b. LINK TEST switch (29) to VALVE.
- 102. If no further testing is required, perform normal shutdown (TM 55-4920-428-13).

END OF RETURN PROOF PRESSURE TEST

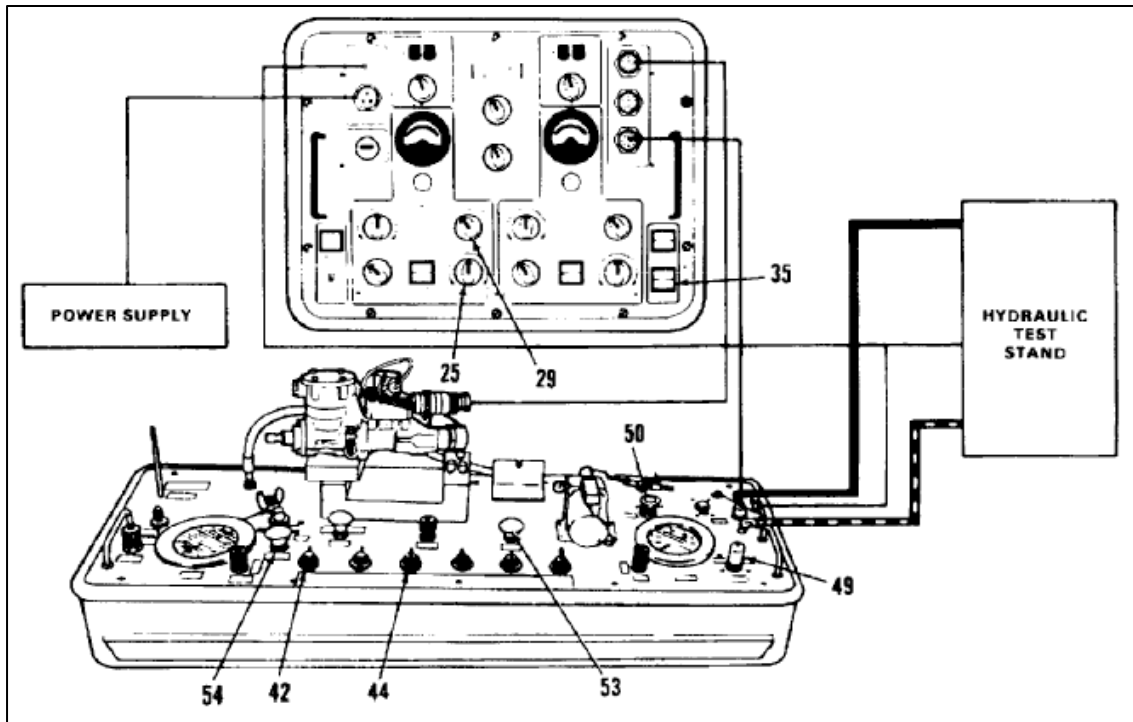

TEST 7

CENTERING SPRING TEST

103. Perform steps 1 thru 35. Check initial control and valve settings step 20 and 21.
104. Set LINK TEST switch (29) to SELF FDBK.
105. Set electrical and hydraulic unit controls as follows:
- Check RETURN SHUTOFF valve (38) is OPEN.
 - SOLENOID valve (50) to OPENED.
 - SOLENOID SHUTOFF switch (35) to OPEN.
 - RETURN SYS 1 valve (42) to RETURN.
- Slowly turn HIGH PRESS regulator valve (49) towards INCREASE until HIGH PRESS gage (51) indicates **1500 psi**.
 - Slowly turn HIGH PRESS SHUTOFF valve (48) to OPEN.
106. Set VALVE CONTROL (25) to EXTEND.
107. AFCS PRESS SYS 1 valve (44) to PRESS.
108. Set AFCS PRESS SYS 1 valve (44) to OFF. Piston (9) shall return to center position within **1 second**. Record reading on DVM (55).
109. Repeat steps 107 and 108 **three times**. Compare recorded readings with first reading. Readings shall be within **0.050** of first reading of step 108.

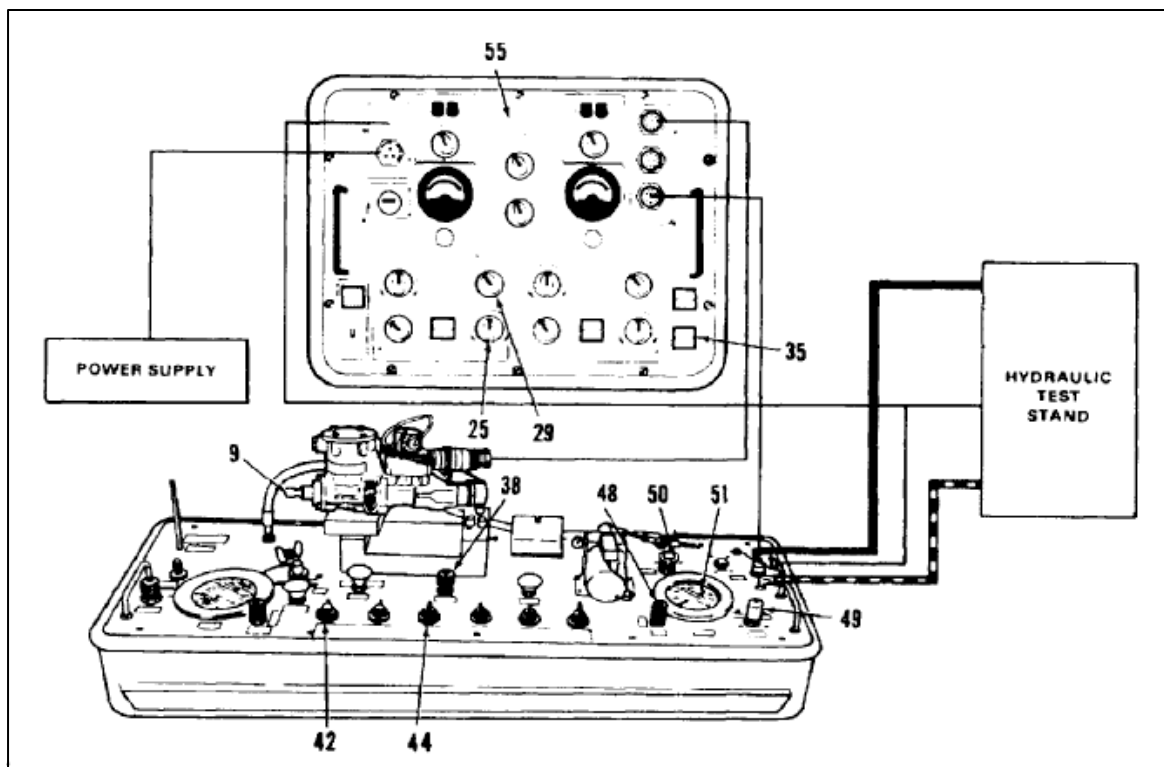

- 110. Set VALVE CONTROL (25) to RETRACT.
- 111. Set AFCS PRESS SYS 1 valve (44) to PRESS.
- 112. Set AFCS PRESS SYS 1 valve (44) to OFF. Piston (9) shall return to center position within **1 second**. Record reading on DVM (55).
- 113. Repeat steps 111 and 112 **three times**. Compare recorded readings with first reading of step 112. Readings shall be within **0.050** of first reading.
- 114. Set electrical and hydraulic unit controls as follows:
 - a. HIGH PRESS REGULATOR valve (49) to DECREASE.
 - b. HIGH PRESS SHUTOFF valve (48) to CLOSE.
 - c. SOLENOID SHUTOFF switch (35) to CLOSE.
 - d. SOLENOID valve (50) to CLOSED.
 - e. AFCS PRESS SYS 1 valve (44) to VENT.
 - f. Push and hold HIGH PRESS RELIEF valve (53) and LOW PRESS RELIEF valve (54) for **15 seconds**.
 - g. AFCS PRESS SYS 1 valve (44) to OFF.
 - h. RETURN SYS 1 valve (42) to OFF.
- 115. Set electrical unit controls as follows:
 - a. VALVE CONTROL (25) to NULL.
 - b. LINK TEST switch (29) to VALVE.
- 116. If no further testing is required, perform normal shutdown (TM 55-4926-428-13).

END OF CENTERING SPRING TEST

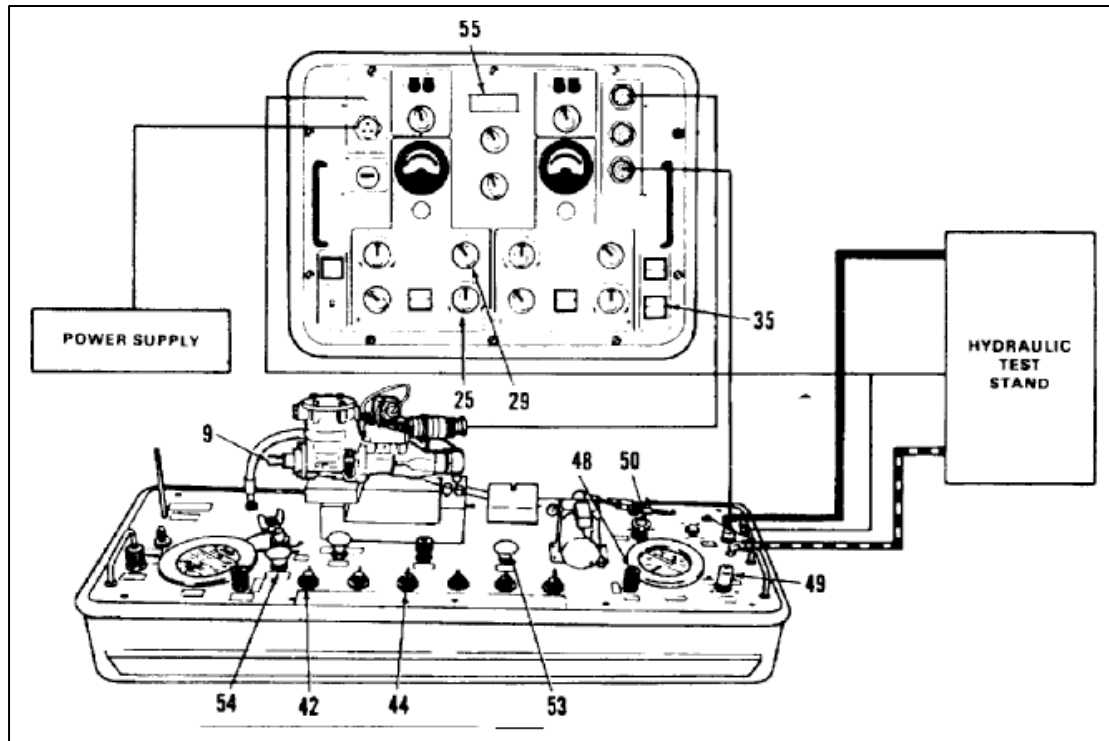

TEST 8

EXTERNAL LEAKAGE TEST

117. Perform steps 1 thru 35. Check initial control and valve settings in steps 20 and 21.
118. Set LINK TEST switch (29) to SELF FDBK.
119. Set electrical and hydraulic unit controls as follows:
 - a. Check RETURN SHUTOFF valve (38) is OPEN.
 - b. SOLENOID valve (50) to OPENED.
 - c. SOLENOID SHUTOFF switch (35) to OPEN.
 - d. RETURN SYS 1 valve (42) to RETURN.
 - e. AFCS PRESS SYS 1 valve (44) to PRESS.
 - f. Slowly turn HIGH PRESS REGULATOR valve (49) towards INCREASE until HIGH PRESS gage (51) indicates **1500 psi**.
 - g. Slowly turn HIGH PRESS SHUTOFF valve (48) to OPEN.
120. Set FUNCTION SELECT switch (21) to SQ WAVE.
121. Turn SQ WAVE control (27) towards MAX until piston (9) moves about **5/16 inch**. Allow piston to cycle for **15 minutes**.
122. Check static seals for leaks. There shall be no leaks.

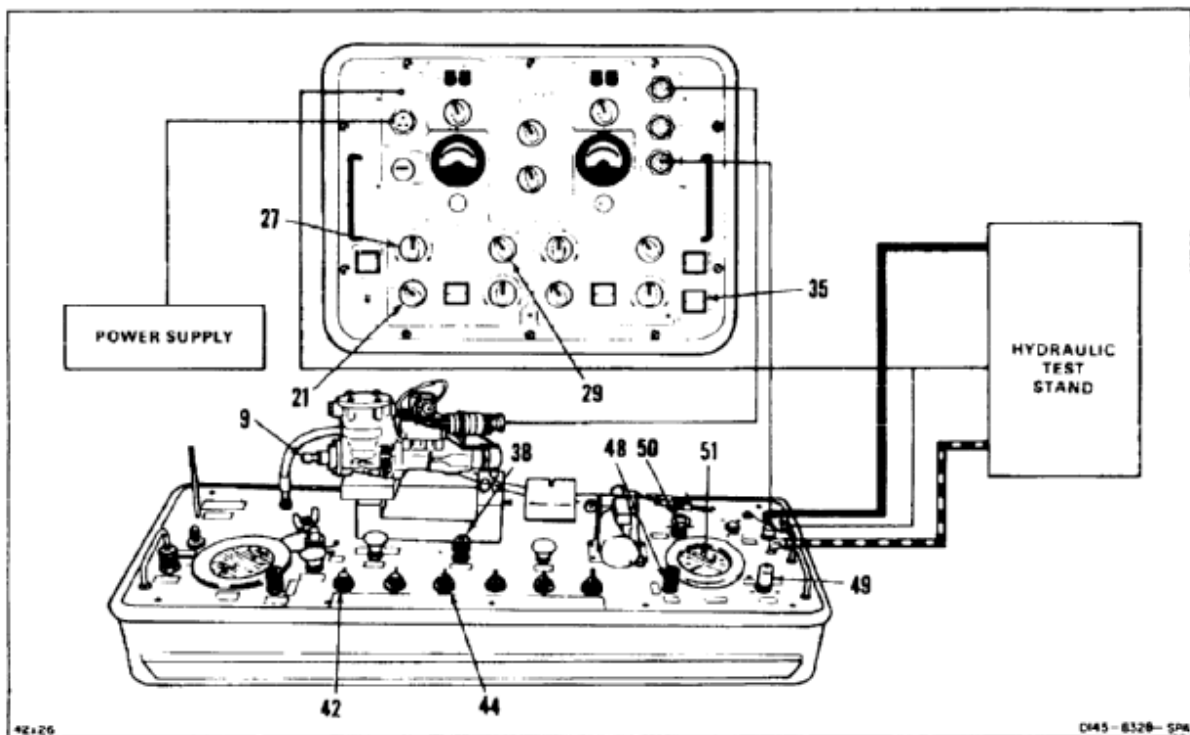

- 123. Check piston (9) seal for leaks. There shall be no more than **1 drop in 1 minute and 40 seconds**.
- 124. Set electrical and hydraulic unit controls as follows:
 - a. HIGH PRESS REGULATOR valve (49) to DECREASE.
 - b. HIGH PRESS SHUTOFF valve (48) to CLOSE.
 - c. SOLENOID SHUTOFF switch (35) to CLOSED.
 - d. SOLENOID valve (50) to CLOSED.
 - e. AFCS PRESS SYS 1 valve (44) to VENT.
 - f. Push and hold HIGH PRESS RELIEF valve (53) and LOW HIGH PRESS RELIEF valve (54) for **15 seconds**.
 - g. AFCS PRESS SYS 1 valve (44) to OFF.
 - h. RETURN SYS 1 valve (42) to OFF.
- 125. Set electrical unit controls as follows:
 - a. FUNCTION SELECT switch (21) to CLSD LOOP.
 - b. SQ WAVE control (27) to MIN.
 - c. LINK TEST switch (29) to VALVE.
- 126. If no further testing is required, perform normal shutdown (TM 55-4920-428-13).

END OF EXTERNAL LEAKAGE TEST

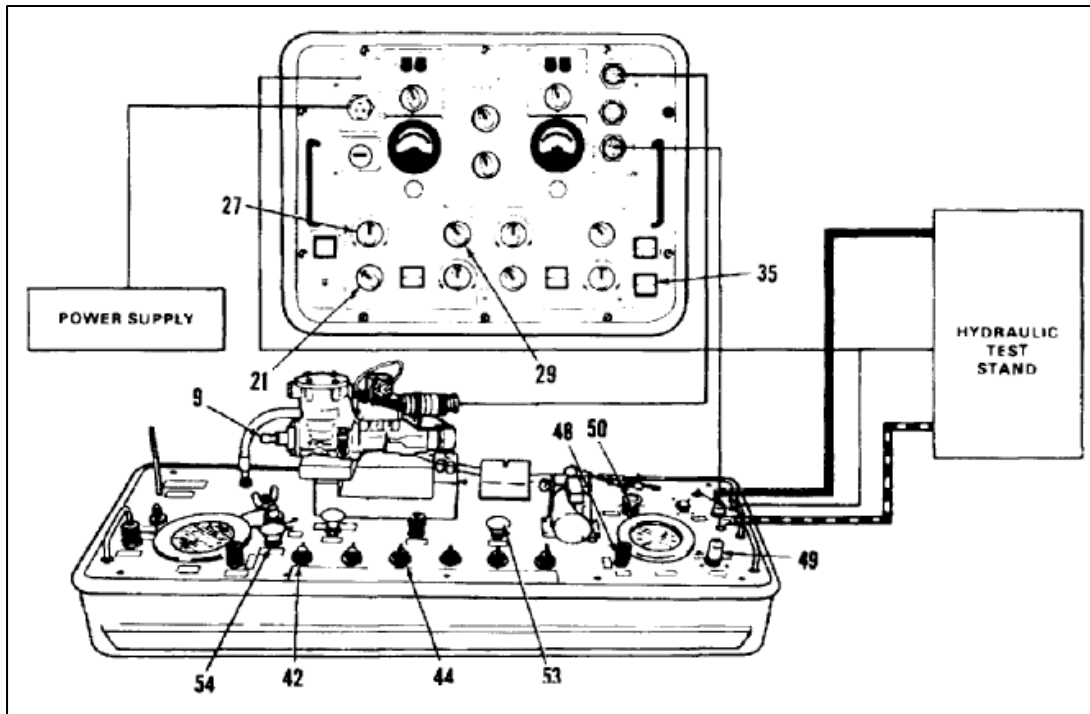

TEST 9**EXTERNAL STATIC LEAK TEST**

127. Perform steps 1 thru 35. Check initial control and valve settings in steps 20 and 21.
128. Set hydraulic unit controls as follows:
 - a. Check RETURN SHUTOFF valve (38) is OPEN.
 - b. SOLENOID valve (50) to OPENED.
 - c. SOLENOID SHUTOFF switch (35) to OPEN.
 - d. RETURN SYS 1 valve (42) to PRESS.
 - e. LOW PRESS REGULATOR valve (41) toward INCREASE until LOW PRESS gauge (58) indicates **60 psi**.
 - f. Slowly turn RETURN BACK PRESS valve (40) slowly to OPEN.
129. Observe piston (9) for **5 minutes**. Check for wetting of external seals. Wetting shall not form more than **1 drop**.

130. Set electrical and hydraulic unit controls as follows:
 - a. LOW PRESS REGULATOR valve (41) to DECREASE.
 - b. RETURN BACK PRESS valve (40) to CLOSE.
 - c. SOLENOID valve (50) to CLOSED.
 - d. SOLENOID SHUTOFF switch (35) to CLOSED.
 - e. RETURN SYS 1 valve (42) to RETURN and then to OFF.
 - f. POWER switch (20) to OFF.

END STATIC LEAK TEST

131. Disconnect cable 145G5278-5 (22) from AFCS 1 receptacle (18) and extensible link receptacle (19). Stow cable in cover.

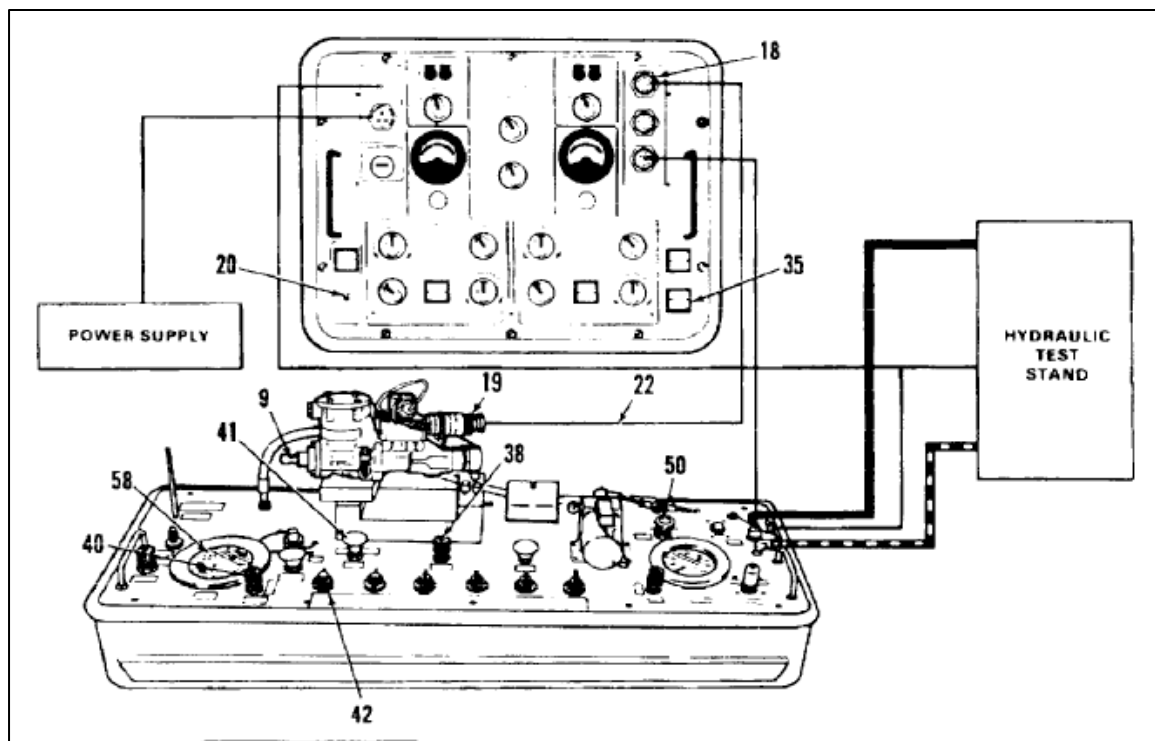

- 132. Reduce test stand input pressure to **0 psi**. Turn off hydraulic test stand.

WARNING

WARNING

Cover is spring-loaded. Remove with caution. Otherwise personnel injury can occur.

Acetone (E20) is extremely flammable. It can be toxic. Avoid inhaling. Use only with adequate ventilation. Avoid contact with skin, eyes, or clothing. Keep away from heat, sparks, or open flame. In case of contact, immediately flush skin or eyes with water for at least **15 minutes**. Get medical attention for eyes.

- 133. Remove two screws (13) from cover (16).
- 134. Install two screws (11) and wing nuts (12) in cover (16). Tighten nuts against cover.
- 135. Remove two screws (13) from cover (16).
- 136. Loosen two wing nuts (12). Remove two screws (11).
- 137. Remove cover (16). Stow cover.
- 138. Clean authority cover (14) with acetone. Remove tag. Wear gloves (E186).
- 139. Install packing (15) on cover (14). Position cover on extensible link (8). Install screws (11). Tighten nuts (12).
- 140. Install two screws (13).
- 141. Remove two screws (11) and stow.
- 142. Install remaining two screws (13).
- 143. Lockwire four screws (13). Use lockwire (E231).

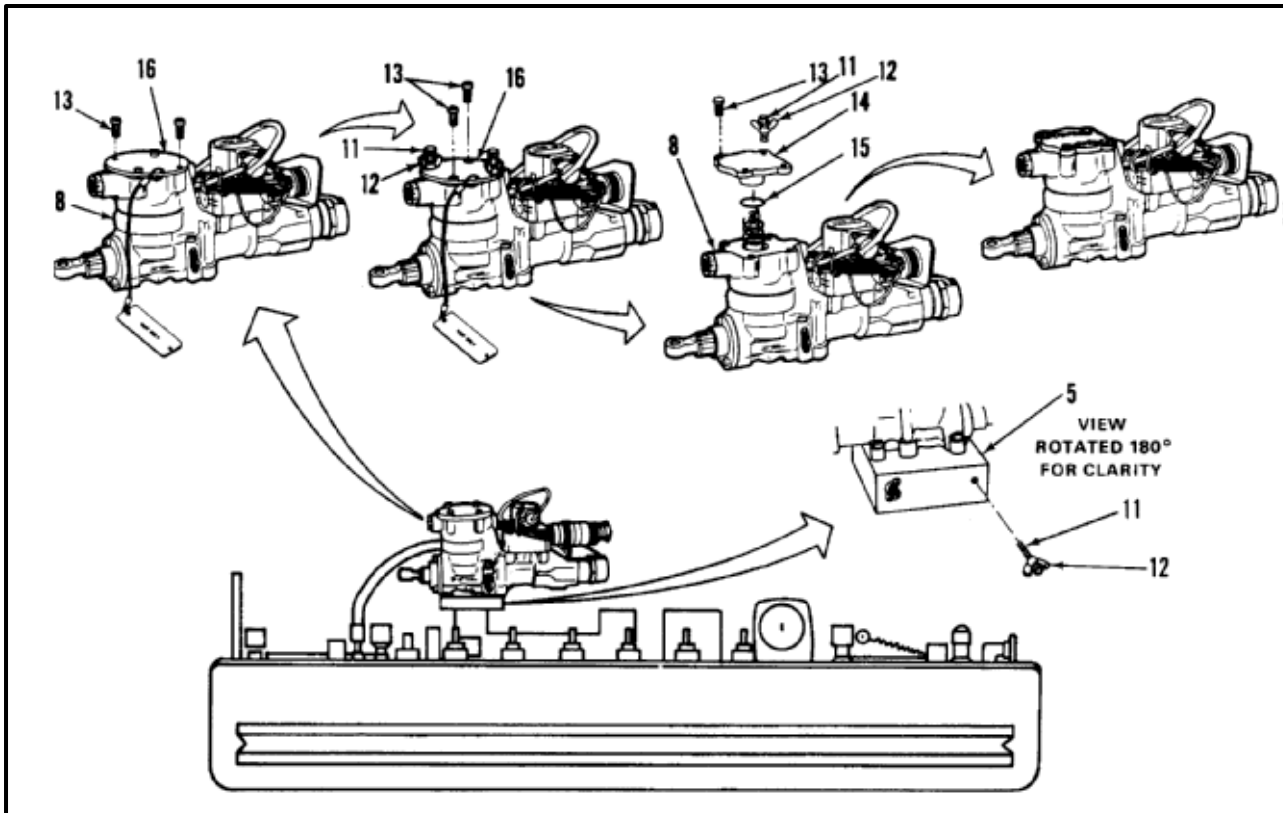

144. Remove three screws (10).
145. Remove link (8). Use cloths (E135) for spilled fluid.
146. Plug ports and cap receptacle.

149. Remove dial indicator (3). Stow indicator on manifold (7).
150. Shut down integrated lower control actuator bench test set 145GS278-1 (TM 55-4920-428-13).

INSPECT

147. Remove two screws (4) from adapter (5). Remove adapter.
148. Position adapter (5) on test unit. Install two screws (4).

FOLLOW-ON MAINTENANCE:

None

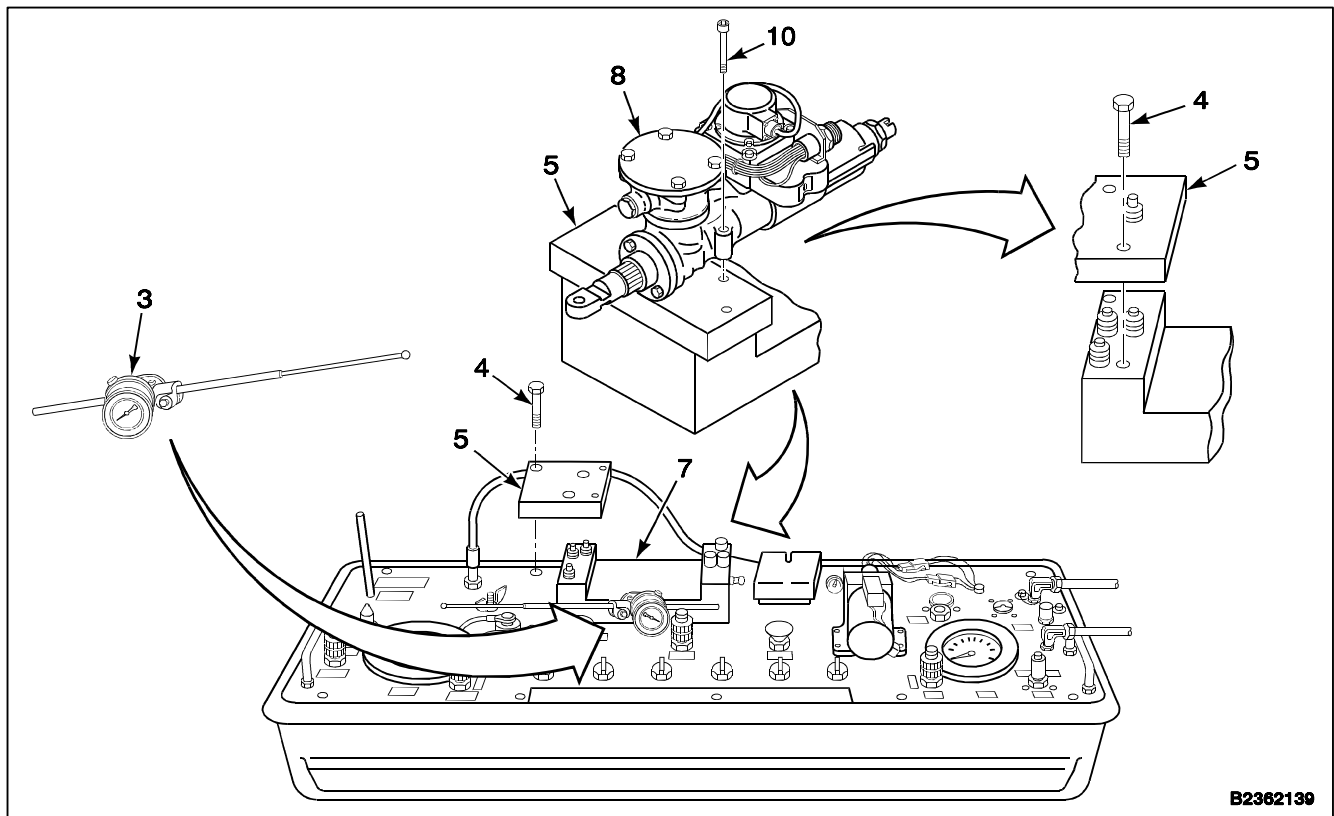

B2362139

END OF TASK

INITIAL SETUP

Applicable Configurations:

All

Tools:

Integrated Lower Control Actuator Bench Test Set
145GS278-1
Power Source, 115 Volt, 60 Hz AC
Hydraulic Test Stand D5 or Equivalent
Safety Ground Cable
Hydraulic Repairer's Tool Kit, NSN 5180-00-323-4891
Torque Wrench, 0-150 Inch-Pounds
Face Shield
Stop Watch
Multimeter (Low Ohm) (T7)

Materials:

Acetone (E20)
Cloths (E135)
Lockwire (E231)
Sealant (E336)
Paper Tags (E264)
Gloves (E184.1)
Hydraulic Fluid (E199)

Parts:

Preformed Packings

Personnel Required:

Aircraft Pneudraulics Repairer
Avionic Navigation and Flight Control Equipment
Repairer
Inspector

References:

TM 55-4920-428-13
Task 7-88
Task 7-88.1
Task 7-100
Task 7-101

Equipment Condition:

Off Helicopter Task
Integrated Lower Control Actuator Bench Test Set
Prepared for Use

General Safety Instructions:

WARNING

Hydraulic fluid (E199) is toxic. It can irritate skin and cause burns. Avoid inhaling. Use only with adequate ventilation. Avoid contact with skin, eyes, or clothing. In case of contact, immediately flush skin or eyes with water for at least **15 minutes**. Get medical attention for eyes.

WARNING

Wear face shields throughout these tests. Hydraulic fluid ejected under pressure can cause injury to personnel. Hydraulic fluid sprayed into the air is a fire hazard.

WARNING

Acetone (E20) is extremely flammable. It can be toxic. Avoid inhaling. Use only with adequate ventilation. Avoid contact with skin, eyes, or clothing. Keep away from heat, sparks, or open flame. In case of contact, immediately flush skin or eyes with water for at least **15 minutes**. Get medical attention for eyes.

WARNING

Sealant (E336) can irritate skin and cause burns. Avoid contact with skin, eyes, or clothing. In case of contact, immediately flush skin or eyes with water for at least **15 minutes**. Get medical attention for eyes.

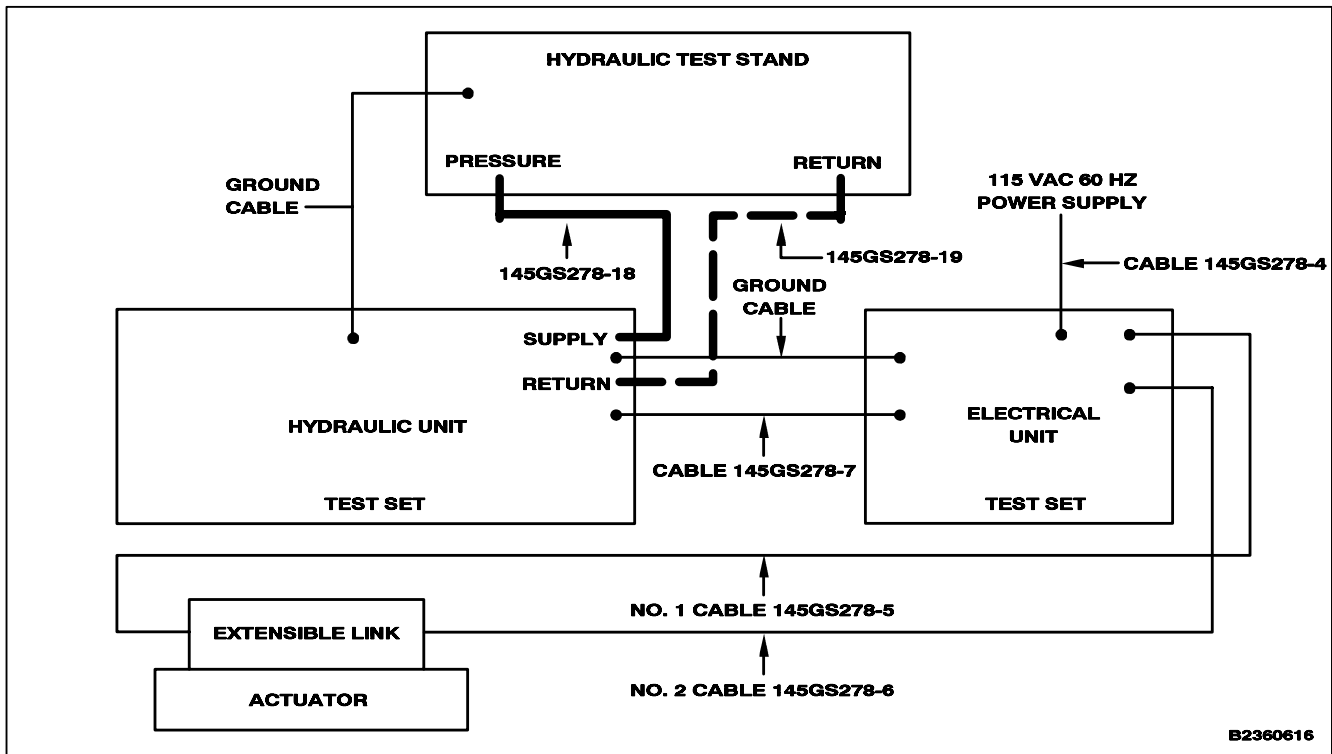

NOTE

Pitch, roll, and yaw ILCA are tested as spare ILCA.

(SPARE) indicates test applies to spare ILCA only.

(ALL) indicates test applies to spare and thrust ILCA.

Thrust ILCA has no extensible link.

After test set has been in operation, HIGH PRESS gauge and LOW PRESS gauge will not return to **0 psi**. When shutoff and regulator valves are closed and relief valves are pressed, the HIGH PRESS gauge may read **20 to 35 psi**. The LOW PRESS gauge may read **25 to 60 psi**. This is normal. Preliminary procedures and the following tests are included:

TEST

1. Ground Test
2. No. 1 Extensible Link Self Feedback Transducer Null Voltage Test (SPARE)
3. No. 2 Extensible Link Self Feedback Transducer Null Voltage Test (SPARE)
4. Extensible Link Cross Feedback Transducer Null Voltage Test (SPARE)

5. No. 1 and No. 2 Extensible Link Phase Test (SPARE)
6. Manual Cycling Test (ALL)
7. Cylinder Stroke Test (ALL)
8. Extensible Link Authority Test (SPARE)
9. Static Deadband Test (ALL)
10. Extensible Link Stability Test (SPARE)
11. Extensible Link Centering Springs Test (SPARE)
12. Proof Pressure Test (ALL)
13. Return Pressure Test (ALL)
14. Valve Jam Indicator Test (ALL)
15. Case Cavity Leakage Test (ALL)
16. Relief Valve Test (ALL)
17. External Dynamic Leakage Test (SPARE)
18. External Static Leakage Test (ALL)
19. Teardown Procedure
20. Centering Spring Test
21. Stability Test

NOTE

Check the Operating Instructions in TM 55-4920-428-13 to verify the ILCA Bench Test Set is prepared for use.

TEST TABLE

The test table is based on recognizable malfunctions and symptoms and is for reference only.

MALFUNCTION	SYMPTOMS	TESTS
Electrical SELF LVDT #1 SELF LVDT #2 SUM LVDT	a. Bite Failure, 70 thru 71 and 80 thru 84 b. Engagement error c. Chattering link d. Oscillations in Pitch, Roll, or Yaw	2, 3, 4, 5, 6, 8, 9, 10
Hydraulic Leakage	Lower Boost Actuator Leakage #1 or #2 Extensible Link Leakage	6, 11, 12, 14, 15, 16, 17 11, 12, 16, 17
Mechanical	Jam Indicator will not extend Lower Boost will not go through full travel	13 6, 7

PRELIMINARY PROCEDURE

NOTE

Steps 1 thru 41 apply to spare ILCA.

Steps 1 thru 7 apply to thrust ILCA.

1. Setup hydraulic unit controls as follows:
 - a. ILCA PRESS SYS 1 valve (1) to VENT.
 - b. ILCA PRESS SYS 2 valve (2) to VENT.
 - c. SAS PRESS SYS 1 valve (3) to VENT.
 - d. SAS PRESS SYS 2 valve (4) to VENT.
 - e. RETURN SYS 1 valve (5) to RETURN.
 - f. RETURN SYS 2 valve (6) to RETURN.

2. Remove thumbscrew (7) from manifold (8).
3. Remove dial indicator (9). Stow indicator in cover.
4. Slide four screws (10) out of manifold (8).



Packings must not be damaged; otherwise, actuator will malfunction.

5. Position actuator (11) on manifold (8) with input (12) to right.
6. Check that actuator (11) is seated. Install four screws (10). Torque to **30-35 inch-pounds**.

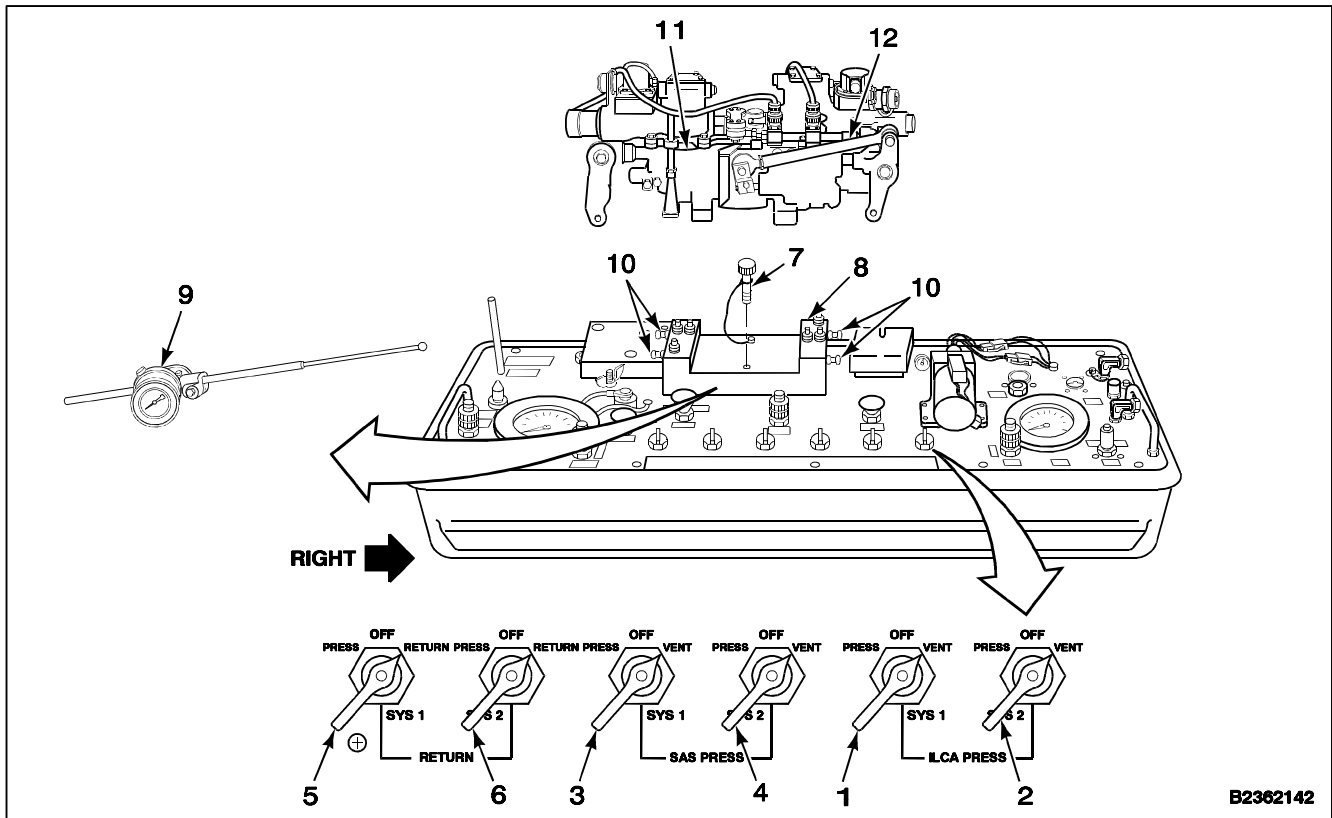

7. Check HIGH PRESS gauge (13) and LOW PRESS gauge (14) for **0 psi** reading.
8. Connect No. 1 cable 145GS278-5 (15) between SAS 1 receptacle (16) and No. 1 extensible link receptacle (17).
9. Connect No. 2 cable 145GS278-6 (18) between SAS 2 receptacle (19) and No. 2 extensible link receptacle (20).
- 9.1. Connect test cable 145GS278-7 (20.1) between electrical receptacle (20.2) and hydraulic unit receptacle (20.3).

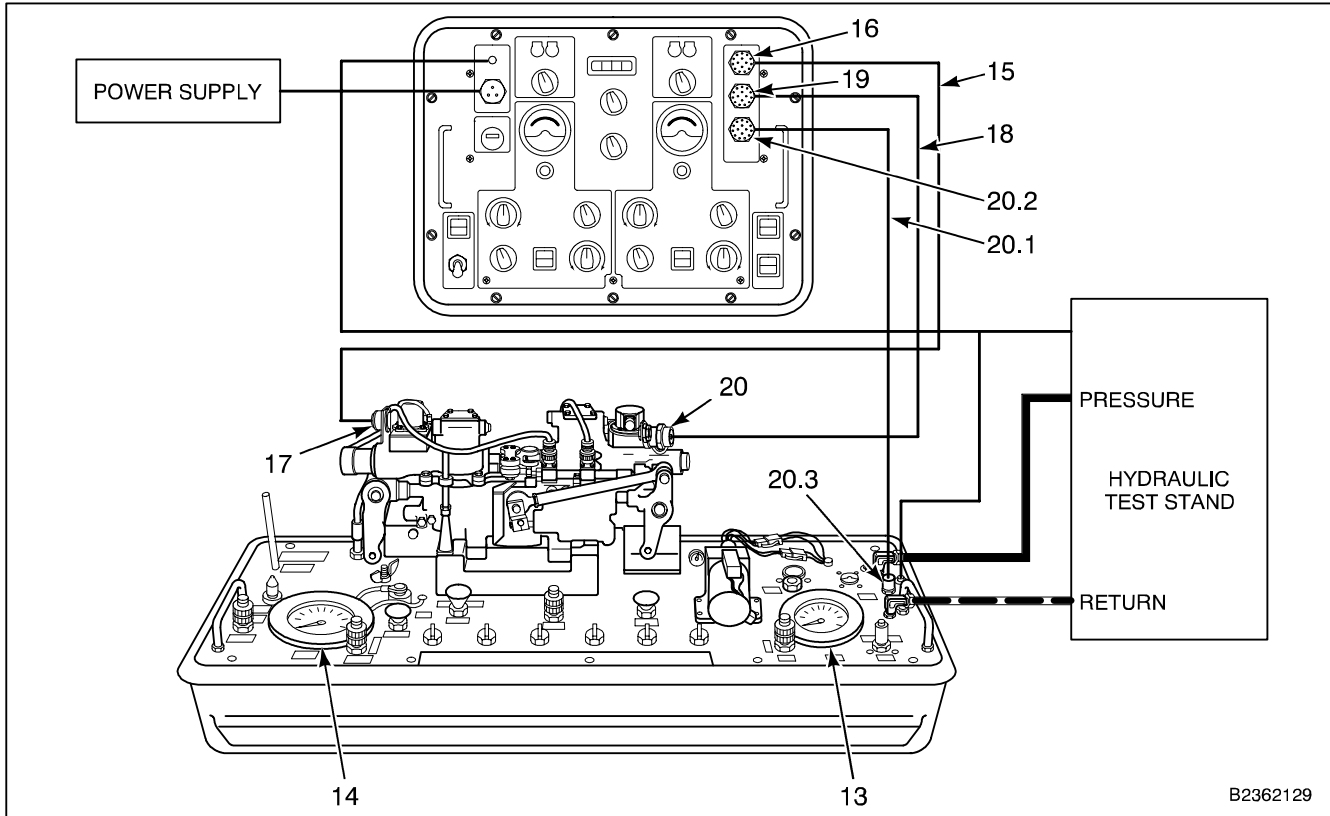

NOTE

Procedure is same to remove No. 1 or No. 2 authority cover from extensible link. Removal of No. 2 cover is shown here. Complete one authority cover installation at a time.

10. Remove lockwire from four screws (21). Remove two opposing screws.
11. Remove two screws (22) and wing nuts (24) from manifold (23).
12. Install two screws (22) with wing nuts (24) in holes of screws (21). Tighten wing nuts against cover (25).

WARNING

Cover is spring-loaded. Remove with caution; otherwise, personal injury can occur.

13. Remove remaining two screws (21).
14. Loosen two wing nuts (24). Remove two screws (22).

15. Tag and remove cover (25). Put cover aside.

WARNING

Acetone (E20) is extremely flammable. It can be toxic. Avoid inhaling. Use only with adequate ventilation. Avoid contact with skin, eyes, or clothing. Keep away from heat, sparks, or open flame. In case of contact, immediately flush skin or eyes with water for at least **15 minutes**. Get medical attention for eyes.

16. Clean test cover 145GS278-12 (26) with acetone.
17. Install packing MS278775-129 (27) on cover (26). Position cover to No. 2 extensible link (28). Install screws (22). Tighten nuts (24).
18. Install two screws (21).
19. Remove two screws (22) and wing nut (24).
20. Stow screws (22) and nuts (24).
21. Install remaining two screws (21).
- 21.1. Repeat steps 10 thru 21 for other extensible links.

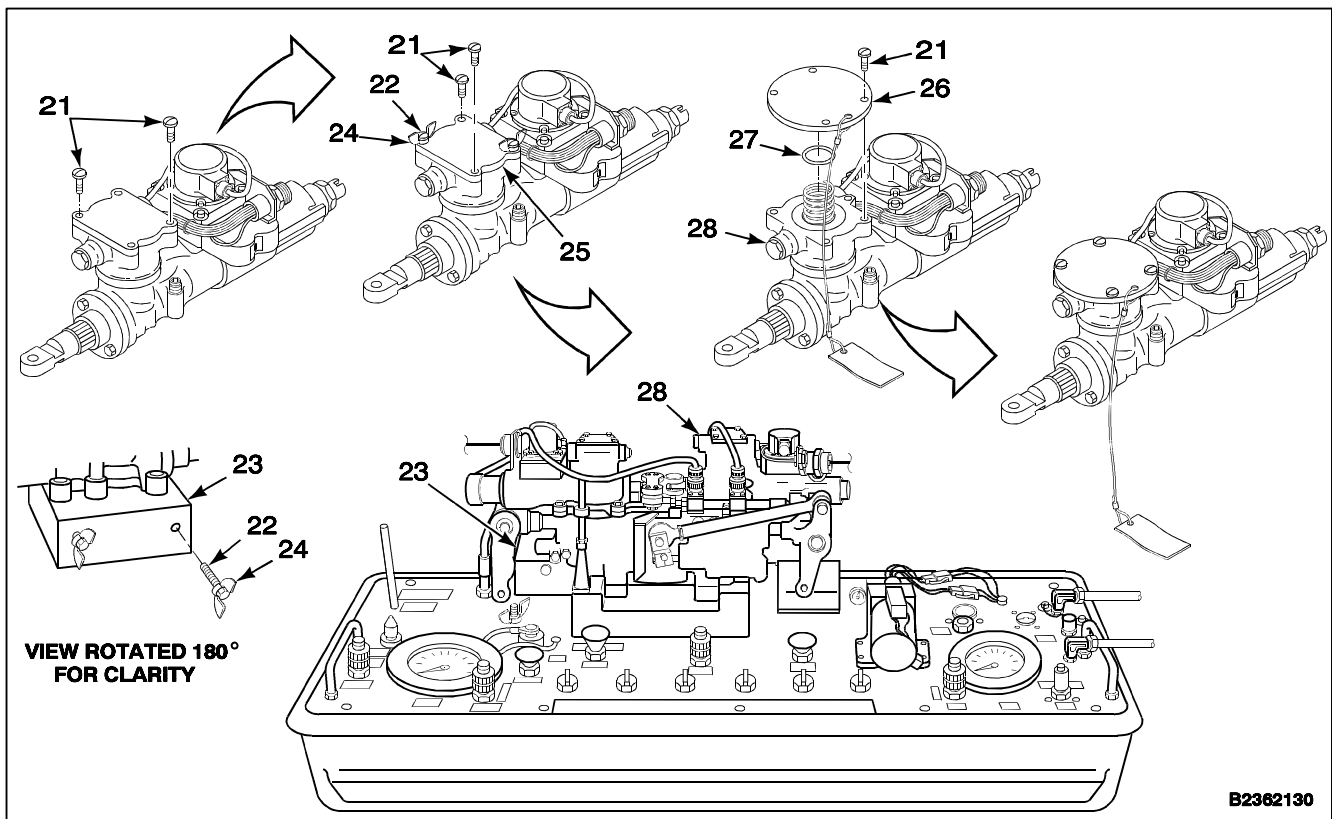

22. Set electrical unit controls as follows:

Initial Settings of Electrical Unit Controls

CONTROL IDENTIFICATION	POSITION REQUIRED
Power switch (29)	OFF
Both FUNCTION SELECT switches (30 and 31)	CLSD LOOP
Both FEEDBACK SELECT switches (32 and 33)	SELF
Both VALVE CONTROLS (34 and 35)	NULL
Both SQ WAVE controls (36 and 37)	MINIMUM
Both LINK TEST switches (38 and 39)	VALVE
Both EXTERNAL METER SELECT switches (40 and 41)	SELF FDBK
BITE switch (42)	-20V (FULL CCW)
SYSTEM SELECT switch (43)	BITE
SOLENOID SHUTOFF switch (44)	CLOSE
CYCLE MOTOR switch (45)	OFF
POWER switch (29)	ON
LAMP TEST switch (46)	Press, check 8 lamps are lit. Release, lamps go out.

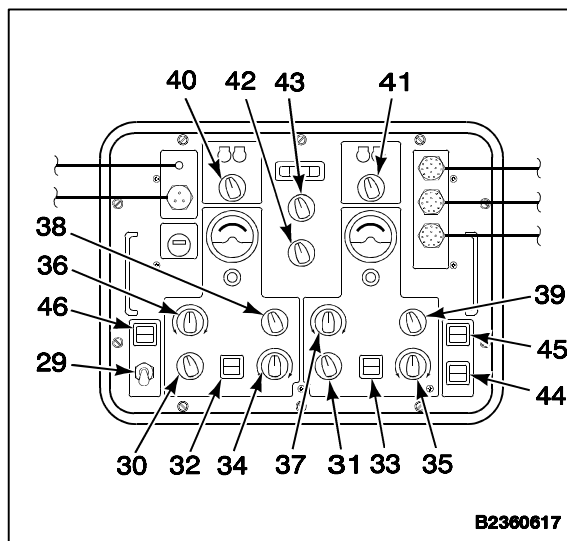

23. Set hydraulic unit controls as follows:

Initial Settings of Hydraulic Unit Controls

VALVE IDENTIFICATION	POSITION REQUIRED
----------------------	-------------------



RETURN SHUTOFF VALVE shall be OPEN unless otherwise required for a specific test.

RETURN SHUTOFF VALVE (47)	Full OPEN
CASE VENT LINE PRESS valve (48)	Full CLOSE
RETURN BACK PRESS valve (49)	Full CLOSE
LOW PRESS REGULATOR valve (50)	Full DECREASE
Both RETURN valves (5 and 6)	OFF
Both SAS PRESS valves (3 and 4)	OFF
Both ILCA PRESS valves (1 and 2)	OFF
HIGH PRESS SHUTOFF VALVE (51)	Full CLOSE
HIGH PRESS REGULATOR valve (52)	Full DECREASE
SOLENOID valve (53)	CLOSED (in)

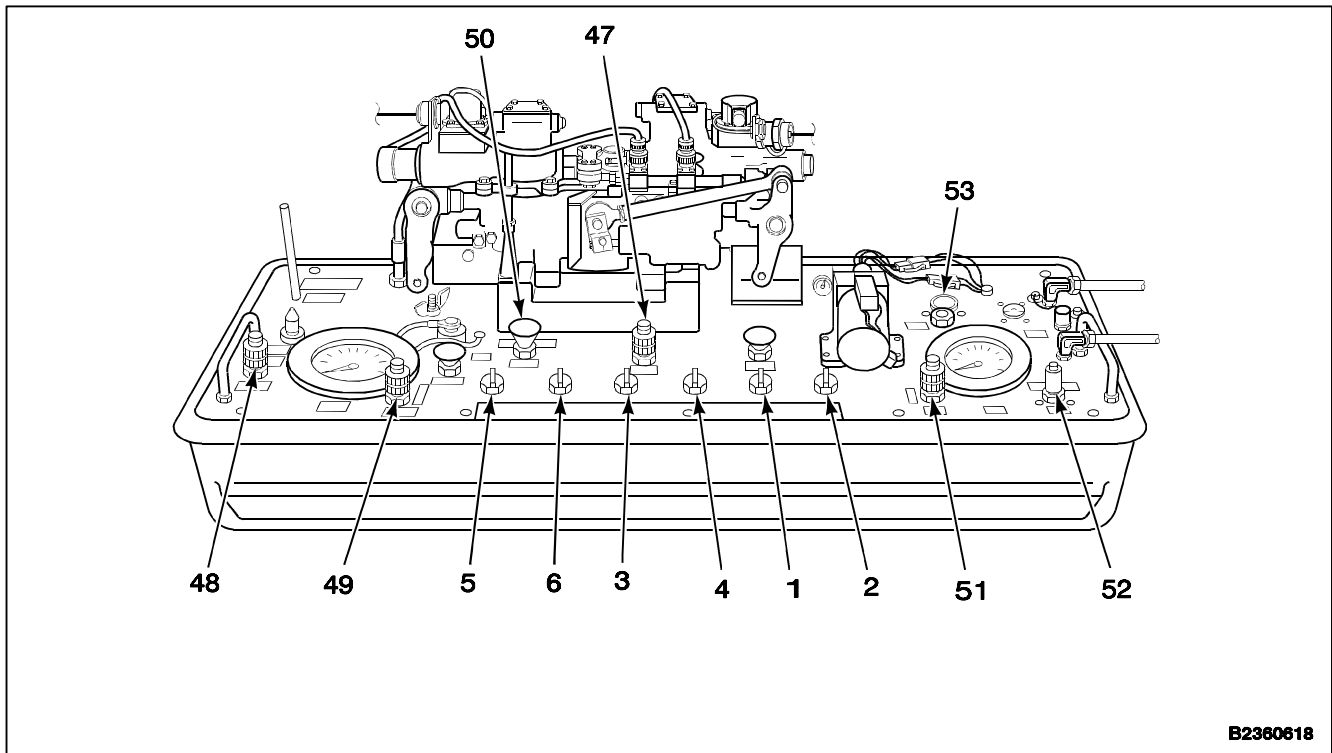

B2360618

24. Apply test stand hydraulic pressure of **1500 psi**.
25. Set electrical unit controls as follows:
 - a. Power switch (29) to ON.
 - b. SOLENOID SHUTOFF switch (44) to OPEN.
26. Set hydraulic unit controls as follows:
 - a. Check that RETURN SHUTOFF VALVE (47) is fully OPEN.
 - b. Set SOLENOID VALVE (53) to OPEN.
 - c. Both SAS SYS 1 valve (3) and SAS SYS 2 valve (4) to PRESS.
 - d. Both ILCA SYS 1 valve (1) and ILCA SYS 2 valve (2) to PRESS.
 - e. Both RETURN SYS 1 (5) and RETURN SYS 2 (6) valves to RETURN.
27. Slowly turn HIGH PRESSURE REGULATOR valve (52) toward INCREASE until HIGH PRESS gauge (13) indicates **100 to 150 psi**.
28. Remove lockwire from No. 1 extensible link (54) bleed cap (55).
29. Crack HIGH PRESS SHUTOFF valve (51) to limit flow for bleeding of air.
30. Loosen cap (55). Bleed until fluid is air-free. Use cloths (E135) to remove spilled fluid. Wear gloves (E184.1).
31. Tighten cap (55). Use cloths (E135) to remove spilled fluid. Wear gloves (E184.1).
32. Remove lockwire from bleed cap (56) of No. 2 extensible link (28).
33. Loosen cap (56). Bleed until fluid is air-free. Use cloths (E135) to remove spilled fluid. Wear gloves (E184.1).
34. Tighten cap (56). Use cloths (E135) to remove spilled fluid. Wear gloves (E184.1).
35. Slowly turn HIGH PRESSURE REGULATOR valve (52) toward INCREASE until HIGH PRESS gauge (13) indicates **1500 psi**.

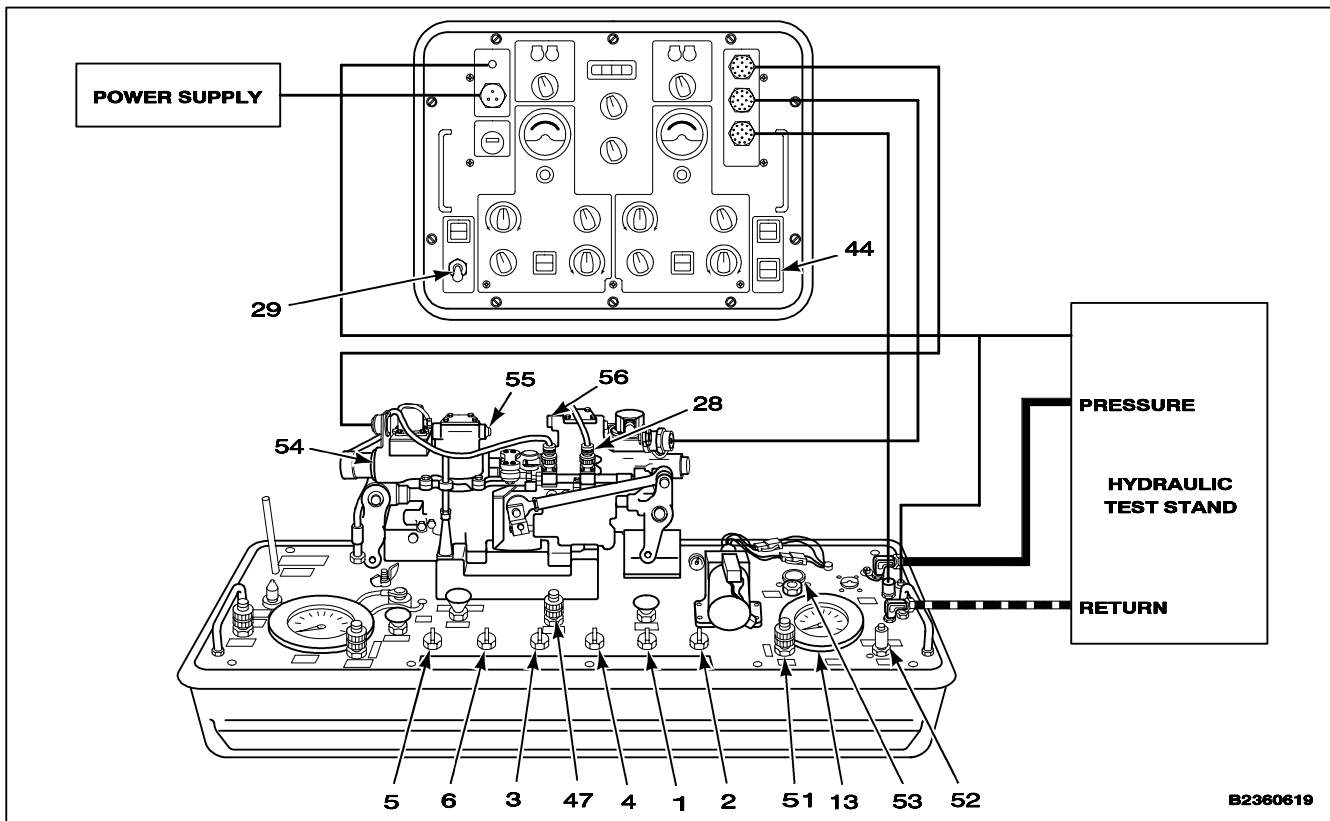

- 36. Slowly open HIGH PRESSURE SHUTOFF valve (51), manually cycle ILCA input arm (61) through full travel, approximately **20 cycles**.

NOTE

Repeat step 36 if squealing sound is heard during the last cycle of step 36. It indicates that air is still trapped in the inner boost section of the ILCA.

- 37. Bleed extensible links (pitch, roll, and yaw only). Set switches as follows:
 - a. FUNCTION SELECT switches (30 and 31) to SQ WAVE.
 - b. Set SQ WAVE CONTROL (36 and 37) to mid-travel and allow link to complete **20 cycles**.
 - c. Deleted.
 - d. Deleted.
 - e. Deleted.

NOTE

Repeat step 37 if squealing sound is heard during the last cycle of step 37. It indicates that air is still trapped in the extensible link section of the ILCA.

- 38. Set hydraulic unit controls as follows:
 - a. HIGH PRESS REGULATOR valve (52) to DECREASE.
 - b. HIGH PRESS SHUTOFF valve (51) to CLOSE.
 - c. SOLENOID valve (53) to CLOSED.
 - e. SAS PRESS SYS 1 valve (3) to OFF.
 - d. SAS PRESS SYS 2 valve (4) to OFF.
 - f. Set ILCA PRESS SYS 1 valve (1) to OFF.
 - g. Set ILCA PRESS SYS 2 valve (2) to OFF.
 - h. Return SYS 1 valve (5) to OFF.
 - i. Return SYS 2 valve (6) to OFF.
- 38.1. Set electrical unit controls as follows:
 - a. SOLENOID SHUTOFF switch (44) to CLOSE.
 - b. Power switch (29) to OFF.
- 39. Lockwire caps (55 and 56). Use lockwire (E231).
- 40. Perform applicable Test 1 thru 18 as required.
- 40.1. Deleted.

INSPECT

END PRELIMINARY PROCEDURE

FOLLOW-ON MAINTENANCE:

Test 1 thru 21 as required.

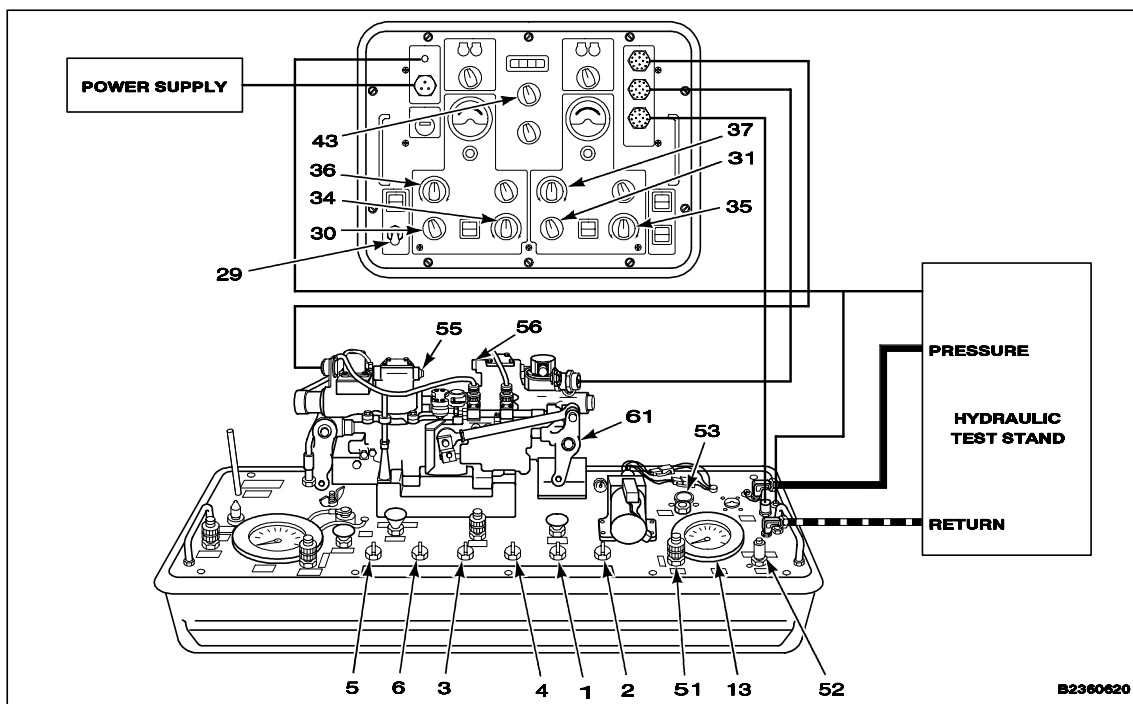

TEST 1

GROUND TEST

- 41. Check resistance from PIN 7 of the SAS 1 cable at the electrical unit test set end to the SAS 1 valve body, using ME518 Multimeter. Measure less than **1 ohm**.

NOTE

If resistance exceeds **1 ohm**, replace servo valve or extensible link.

If extensible link is replaced, perform all extensible link tests.

- 41.1. Check resistance from PIN 7 of the SAS 2 cable at the electrical unit test set end to the SAS valve body, using ME518 Multimeter. Measure less than **1 ohm**.

NOTE

If resistance exceeds **1 ohm**, replace servo valve or extensible link.

If extensible link is replaced, perform all extensible link tests.

END OF GROUND TEST

FOLLOW-ON MAINTENANCE:

Test 2: No. 1 Extensible Link Self Feedback Transducer Null Voltage Test (Spare).

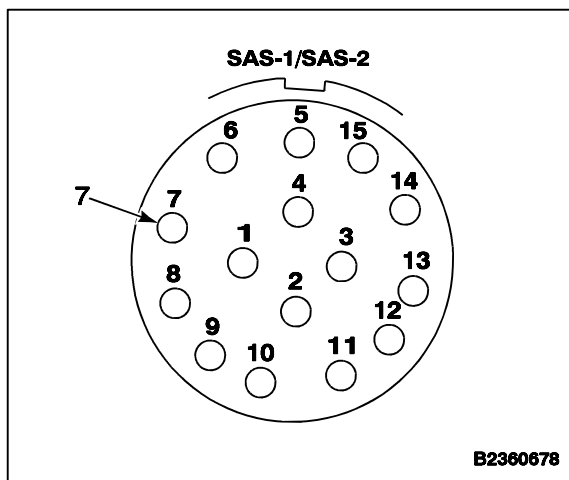

TEST 2

NO. 1 EXTENSIBLE LINK SELF FEEDBACK TRANSDUCER NULL VOLTAGE TEST (SPARE)

NOTE

Tests 2, 3, 4, and 5 MUST be performed in sequence.

42. Perform steps 1 thru 40. Check initial control and valve settings in steps 22 and 23.

43. Set hydraulic unit controls as follows:

- a. ILCA PRESS SYS 1 valve (1) to VENT.
- b. ILCA PRESS SYS 2 valve (2) to VENT.
- c. SAS PRESS SYS 1 valve (3) to VENT.

d. SAS PRESS SYS 2 valve (4) to VENT.

e. RETURN SYS 1 valve (5) to RETURN.

f. RETURN SYS 2 valve (6) to RETURN.

44. Set electrical unit controls as follows:

- a. Power switch (29) to ON.
- b. SYSTEM SELECT switch (43) to SAS 1.
- c. SAS 1 FUNCTION SELECT switch (30) to BALANCE.
- d. SAS 1 FEEDBACK SELECT switch (32) to SELF.
- e. SAS 1 LINK TEST switch (38) to SELF FDBK.

45. DVM (58). Reading shall not exceed **0.0180 volts**. Record reading.

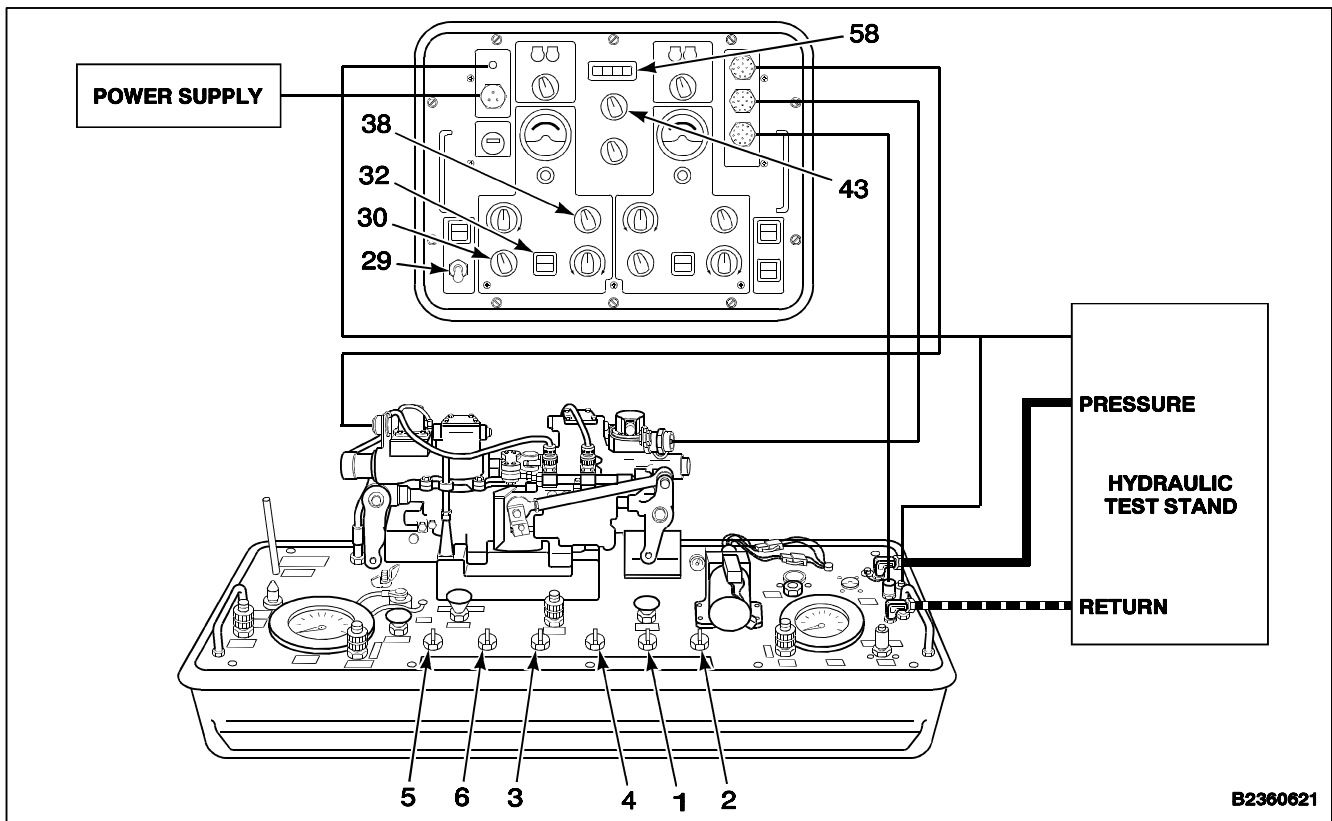

B2360621

NOTE

If reading is greater than **0.0180 volts**, No. 1 extensible link self feedback transducer requires adjustment (Task 7-101). Repeat Test 2 after adjustments.

46. Set up hydraulic unit controls as follows:
- a. ILCA PRESS SYS 1 valve (1) to OFF.
 - b. ILCA PRESS SYS 2 valve (2) to OFF.
 - c. SAS PRESS SYS 1 valve (3) to OFF.
 - d. SAS PRESS SYS 2 valve (4) to OFF.
 - e. RETURN SYS 1 valve (5) to OFF.
 - f. RETURN SYS 2 valve (6) to OFF.

**END NO. 1 EXTENSIBLE LINK SELF FEEDBACK
TRANSDUCER NULL VOLTAGE TEST (SPARE)**

FOLLOW-ON MAINTENANCE:

Test 3: No. 2 Extensible Link Self Feedback
Transducer Null Voltage Test (Spare).

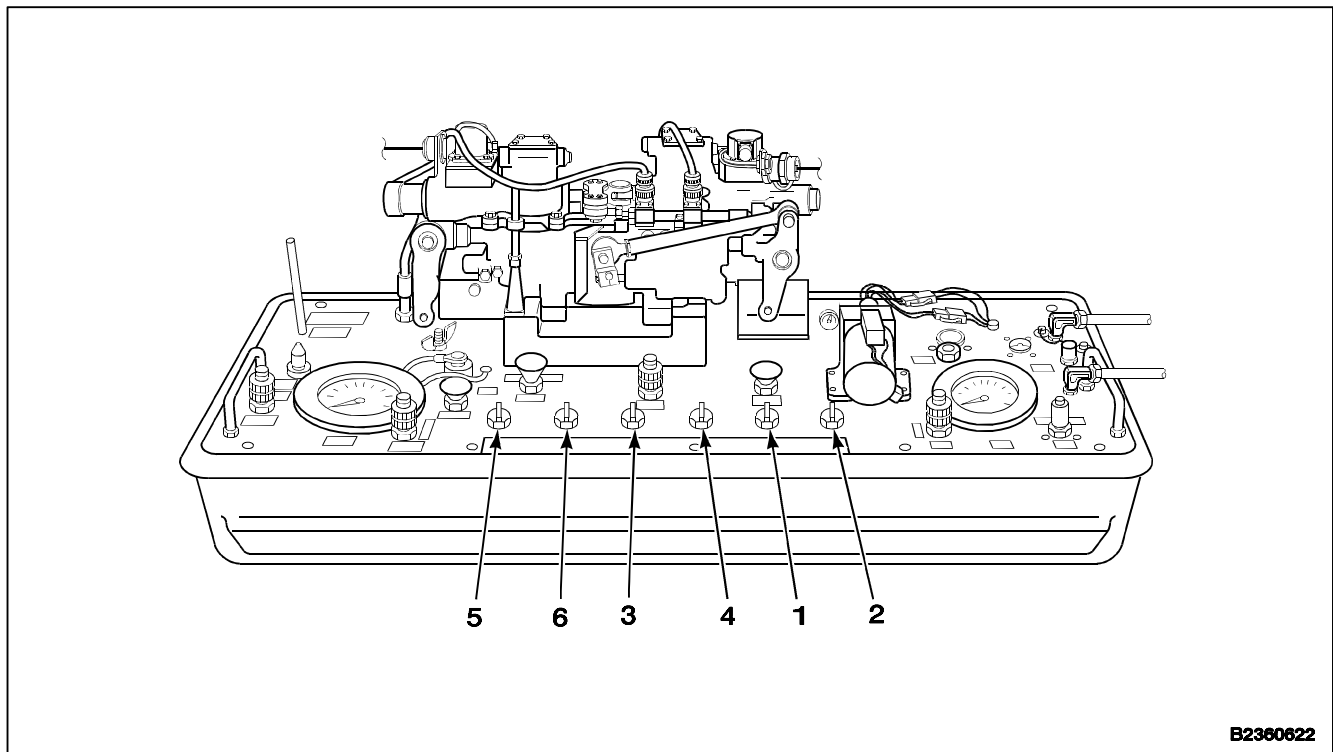

B2360622

TEST 3

NO. 2 EXTENSIBLE LINK SELF FEEDBACK TRANSDUCER NULL VOLTAGE TEST (SPARE)

NOTE

Tests 2, 3, 4, and 5 MUST be performed in sequence.

- 47. Perform steps 1 thru 40. Check initial control and valve settings in steps 22 and 23.
- 48. Setup hydraulic unit controls as follows:
 - a. ILCA PRESS SYS 1 valve (1) to VENT.
 - b. ILCA PRESS SYS 2 valve (2) to VENT.
 - c. SAS PRESS SYS 1 valve (3) to VENT.
 - d. SAS PRESS SYS 2 valve (4) to VENT.
 - e. RETURN SYS 1 valve (5) to RETURN.
 - f. RETURN SYS 2 valve (6) to RETURN.

- 49. Set electrical unit controls as follows:
 - a. Power switch (29) to ON.
 - b. SYSTEM SELECT switch (43) to SAS 2.
 - c. SAS 2 FUNCTION SELECT switch (31) to BALANCE.
 - d. SAS 2 FEEDBACK SELECT switch (33) to SELF.
 - e. SAS 2 LINK TEST switch (39) to SELF FDBK.
- 50. DVM (58). Reading shall not exceed **0.0180 volts**. Record reading.

NOTE

If reading is greater than **0.0180 volts**, No. 2 extensible link self feedback transducer requires adjustment (Task 7-101). Repeat Tests 2 and 3 after adjustment.

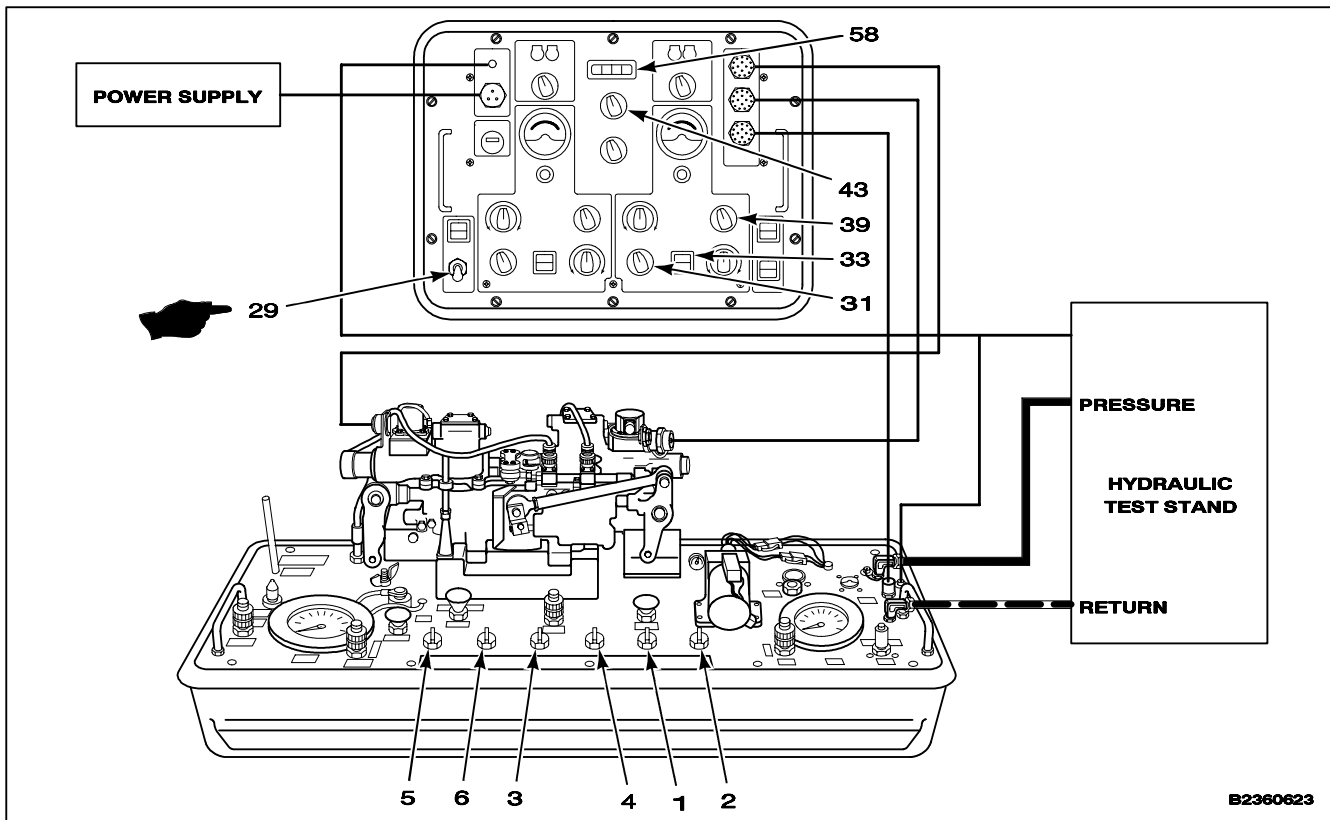

51. Set hydraulic unit controls as follows:
- ILCA PRESS SYS 1 valve (1) to OFF.
 - ILCA PRESS SYS 2 valve (2) to OFF.
 - SAS PRESS SYS 1 valve (3) to OFF.
 - SAS PRESS SYS 2 valve (4) to OFF.
 - RETURN SYS 1 valve (5) to OFF.
 - RETURN SYS 2 valve (6) to OFF.

**END NO. 2 EXTENSIBLE LINK SELF FEEDBACK
TRANSDUCER NULL VOLTAGE TEST**

FOLLOW-ON MAINTENANCE:

- Test 4: Extensible Link Cross Feedback Transducer
Null Voltage Test.

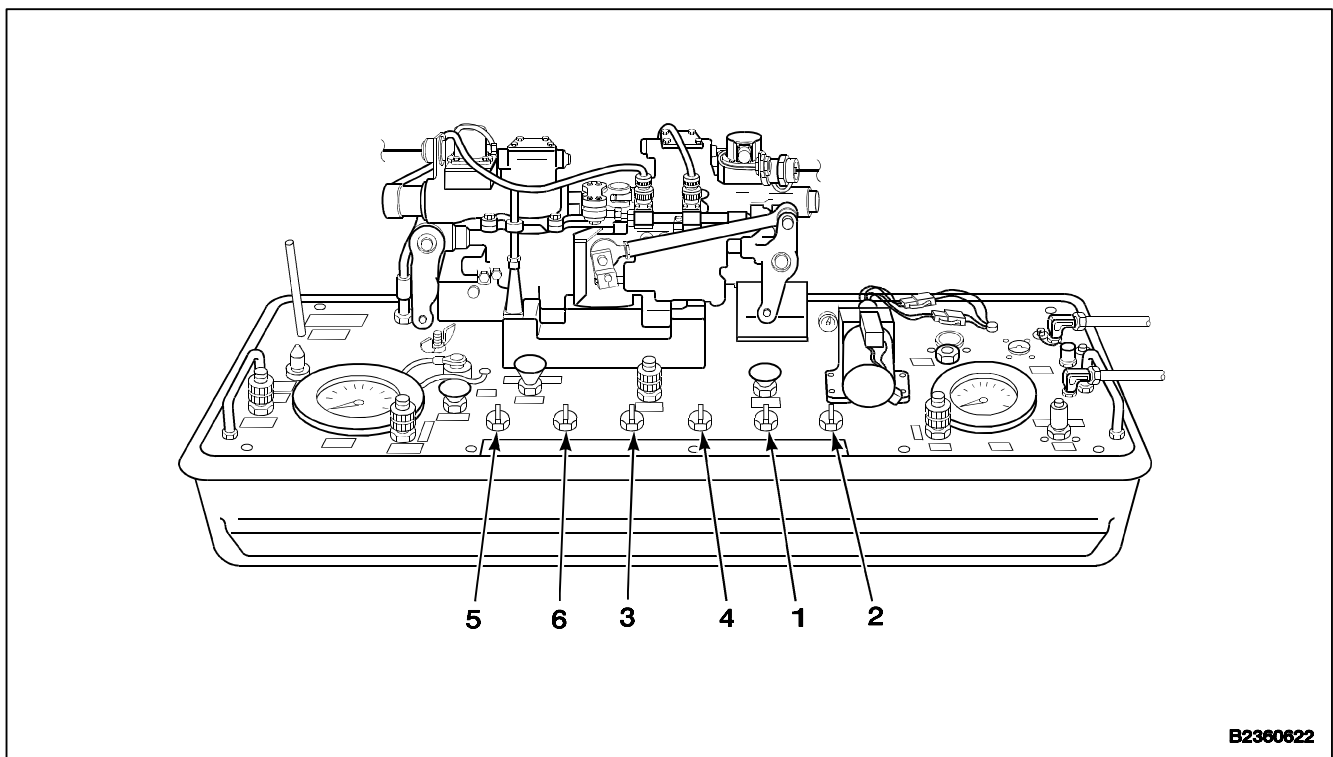

TEST 4

EXTENSIBLE LINK CROSS FEEDBACK TRANSDUCER NULL VOLTAGE TEST (SPARE)

NOTE

Tests 2, 3, 4, and 5 MUST be performed in sequence.

- 52. Perform steps 1 thru 40. Check initial control and valve settings in steps 22 and 23.
- 53. Set hydraulic unit controls as follows:
 - a. ILCA PRESS SYS 1 valve (1) to VENT.
 - b. ILCA PRESS SYS 2 valve (2) to VENT.
 - c. SAS PRESS SYS 1 valve (3) to VENT.
 - d. SAS PRESS SYS 2 valve (4) to VENT.
 - e. RETURN SYS 1 valve (5) to RETURN.
 - f. RETURN SYS 2 valve (6) to RETURN.
- 54. Set electrical unit controls as follows:
 - a. SAS 1 & SAS 2 FUNCTION SELECT switch (30 & 31) to BALANCE.
 - b. SAS 1 & SAS 2 FEEDBACK SELECT switch (32 & 33) to CROSS.
 - c. SAS 1 & SAS 2 LINK TEST switch (38 & 39) to CROSS FDBK.

- d. SYSTEM SELECT switch (43) to SAS 1.
- 55. DVM (58). Reading shall not exceed **0.0180 volts**. Record reading.

NOTE

Reading must be recorded. This reading is needed for other tests.

If reading is greater than **0.0180 volts**, extensible link cross feedback transducer requires adjustment (Task 7-100). Repeat Tests 2, 3, and 4.

- 55.1. Set electrical and hydraulic unit controls as follows:
 - a. SAS 1 FUNCTION SELECT switch (30) to CLSD LOOP.
 - b. RETURN SHUTOFF valve (47) to FULL OPEN.
 - c. SOLENOID valve (53) to OPEN.
 - d. SOLENOID SHUTOFF switch (44) to OPENED.
 - e. Slowly turn HIGH PRESS REGULATOR valve (52) toward INCREASE until HIGH PRESS gauge (13) indicates **1500 psi**.

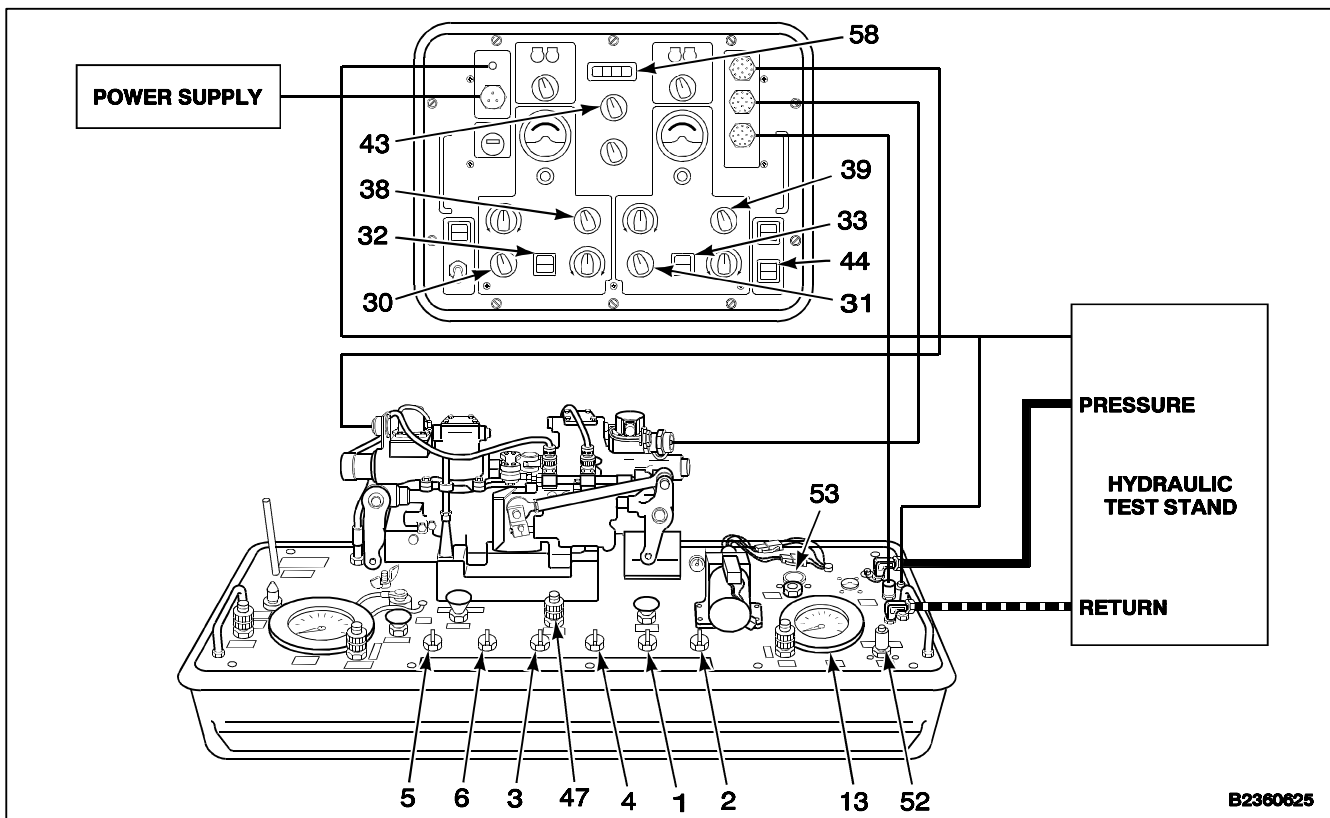

- f. ILCA PRESS SYS 1 valve (1) and SAS PRESS SYS 1 valve (3) to PRESS.
 - g. Slowly turn HIGH PRESS SHUTOFF valve (51) to OPEN.
 - h. Install PIN 2 (69) in input arm (61).
 - i. Slowly turn SAS 1 VALVE CONTROL (34) to full EXTEND.
- 55.2. Record reading indicated on DVM (58).
- 55.2.1. Set electrical unit controls as follows:
- a. SAS 2 FEEDBACK SELECT switch (33) to CROSS.
 - b. SAS 2 LINK TEST switch (39) to CROSS FDBK.
 - c. SYSTEM SELECT switch (43) to SAS 2.
- 55.3. Record DVM (58) reading and compare to reading from step 55.2.
- 55.4. Slowly turn SAS 1 valve control (34) to NULL.
- 55.5. Remove pin 2 (69) from input arm (61). Stow pin.
56. Deleted—Moved to step 55.2.1.
57. Deleted—Moved to step 55.3.
58. Set hydraulic unit controls as follows:
- a. ILCA PRESS SYS 1 valve (1) to OFF.
 - b. ILCA PRESS SYS 2 valve (2) to OFF.
 - c. SAS PRESS SYS 1 valve (3) to OFF.
 - d. SAS PRESS SYS 2 valve (4) to OFF.
 - e. RETURN SYS 1 valve (5) to OFF.
 - f. RETURN SYS 2 valve (6) to OFF.
- END EXTENSIBLE LINK CROSS FEEDBACK TRANSDUCER NULL VOLTAGE TEST**

FOLLOW-ON MAINTENANCE:

Test 5: No. 1 and No. 2 Extensible Link Phase Test (Spare).

NOTE

If difference between steps 55.2 and 55.3 reading is greater than **0.0250**, adjust the extensible link cross feedback transducer (Task 7-100).

If the difference cannot be adjusted, replace extensible link cross feedback transducer. Repeat Tests 2, 3, and 4.

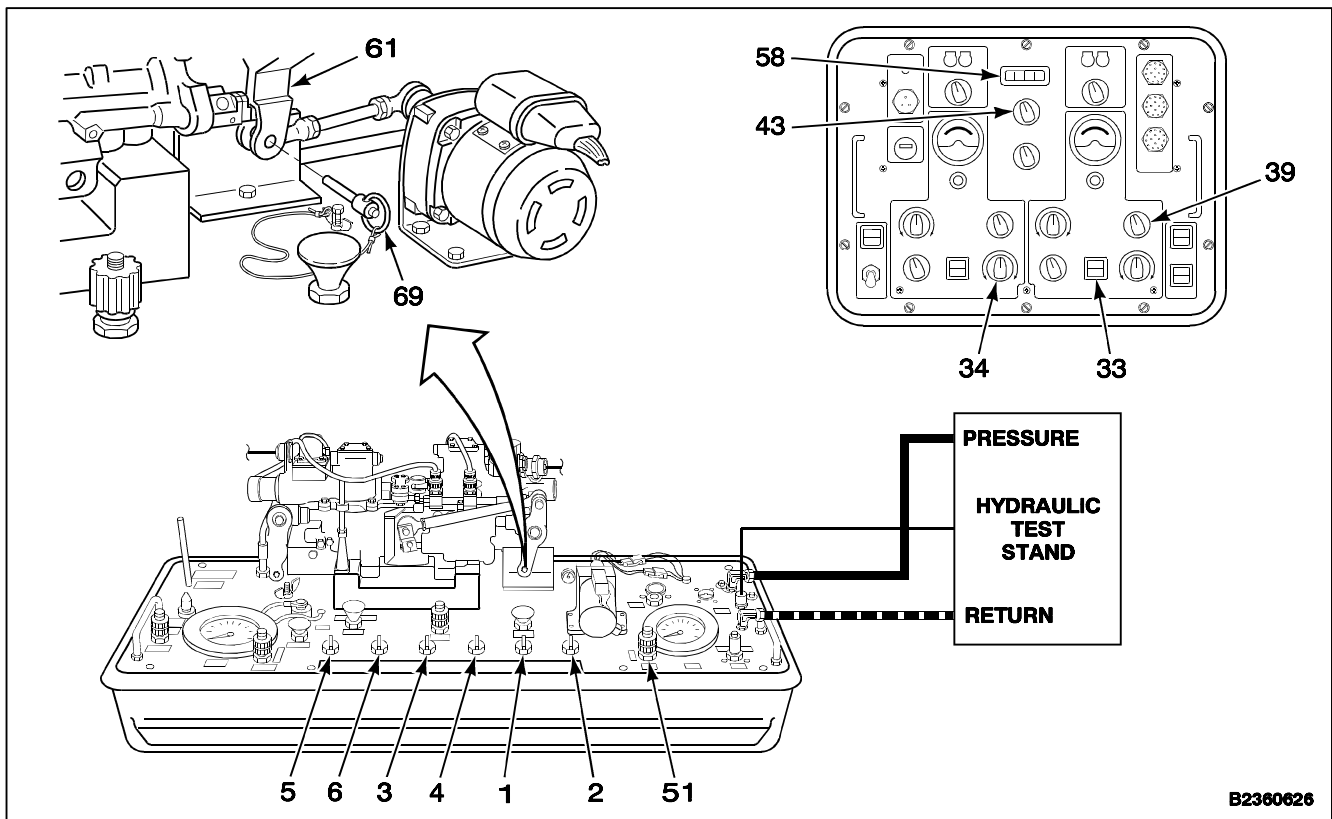

B2360626

TEST 5

NO. 1 AND NO. 2 EXTENSIBLE LINK PHASE TEST (SPARE)

NOTE

Tests 2, 3, 4, and 5 MUST be performed in sequence.

59. Perform steps 1 thru 40. Check initial control and valve settings in steps 22 and 23.

59.1. Set electrical and hydraulic unit controls as follows:

- a. EXTERNAL METER SELECT switches (40 and 41) to SELF FDBK.
- b. SYSTEM SELECT switch (43) to SAS 1.
- c. BITE switch (42) to **+20V**.
- d. SQ WAVE control (36 and 37) to MINIMUM.
- e. LINK TEST switches (38 and 39) to SELF.
- f. FUNCTION SELECT switches (30 and 31) to CLSD LOOP.
- g. FEEDBACK SELECT switches (32 and 33) to SELF.

- h. VALVE CONTROLS (34 and 35) to NULL.
- i. SOLENOID VALVE (53) to OPEN.
- j. SOLENOID SHUTOFF switch (44) to OPEN.

59.2. Apply test stand hydraulic pressure of **1500 psi**.

59.3. Set hydraulic unit controls as follows:

- a. Check that the RETURN SHUTOFF valve (47) is fully OPEN.
- b. Slowly turn HIGH PRESS REGULATOR valve (52) towards INCREASE until HIGH PRESS gauge (13) indicates **1500 psi**.
- c. Slowly open HIGH PRESS SHUTOFF valve (51).
- d. RETURN SYS 1 valve (5) to RETURN.
- e. RETURN SYS 2 valve (6) to RETURN.
- f. ILCA PRESS SYS 1 valve (1) to PRESS.
- g. ILCA PRESS SYS 2 valve (2) to PRESS.

59.4. Install PIN 2 (62) in input arm (61) through fixture (70).

59.5. Set SAS PRESS SYS 1 valve (3) to PRESS.

59.6. Set SAS PRESS SYS 2 valve (4) to VENT.

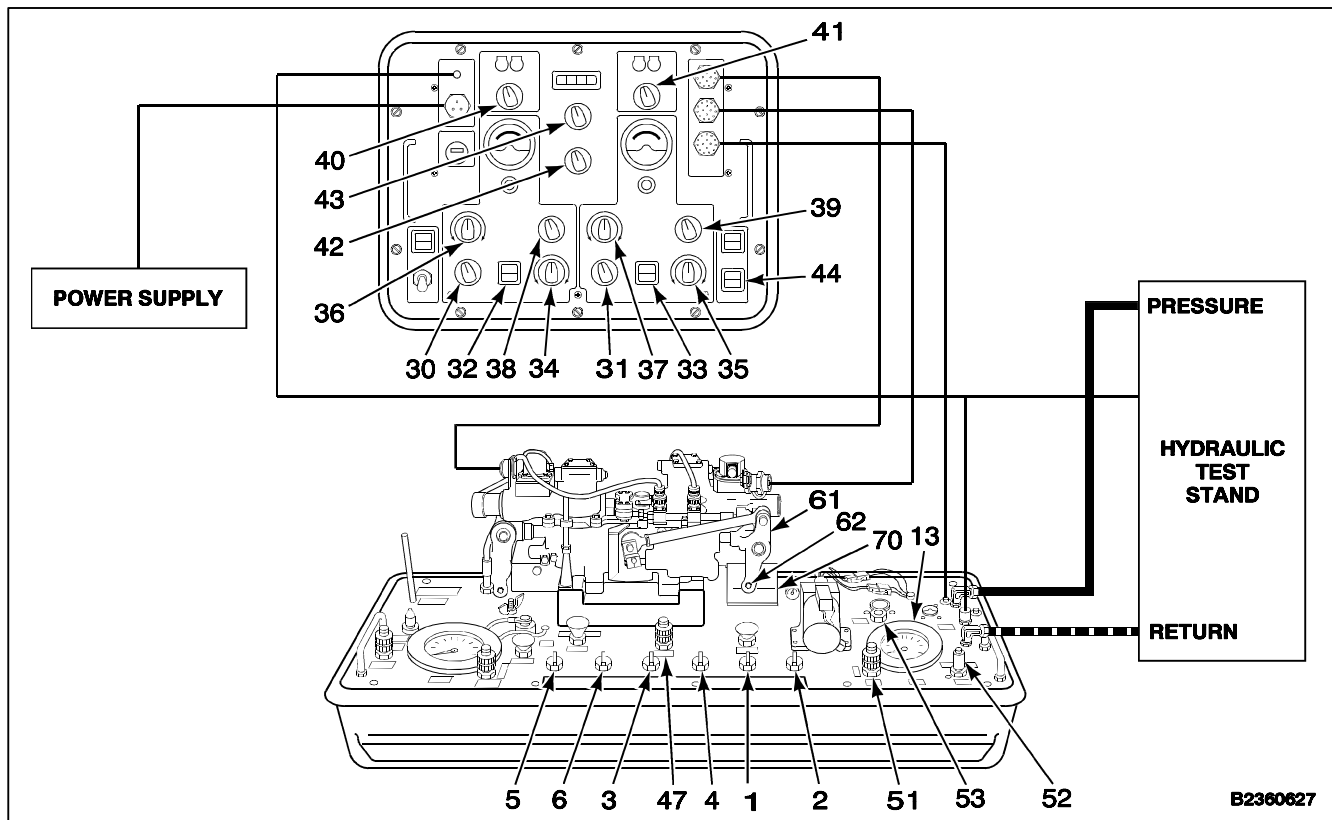

7-98 TEST PITCH, ROLL, YAW, OR THRUST INTEGRATED LOWER CONTROL ACTUATOR (ILCA) (AVIM) (Continued)

59.7. Turn SAS 1 valve control (34) to EXTEND until DVM (58) indicates **1.00 volt**. SAS 1 NULL METER (60.1) must move to the right, indicating **10 ±2 microamp**. If null meter reads to the left, SAS 1 is out-of-phase.

NOTE

If null meter moves to the left, check extensible link wire connections (Task 7-88.1, step 7). If connector is wired correctly, replace No. 1 self LVDT (Task 7-88.1).

59.8. Set SAS 1 LINK TEST switch (38) to CROSS FDBK. DVM (58) must indicate **0.50 ±0.03 volt**. If null meter moves to the left, the ILCA is out-of-phase.

NOTE

If null meter moves to the left, check extensible link wire connections of the cross feedback transducer. If connector is wired correctly, replace cross feedback transducer (Task 7-88).

59.9. Set SAS 1 FEEDBACK SELECT switch (32) to CROSS. NULL METER (60.1) must decrease to **5 ±1 microamp**. If null meter moves to the left, the ILCA is out-of-phase.

NOTE

If null meter moves to the left, check extensible link wire connections of the No. 1 cross feedback transducer. If connector is wired correctly, replace cross feedback transducer. (Task 7-88).

59.10. Set SAS 1 FEEDBACK SELECT switch (32) to SELF.

59.11. Set SAS 1 LINK TEST switch (38) to SELF.

59.12. Turn SAS 1 VALVE CONTROL (34) to RETRACT until DVM (58) indicates **1.00 volt**. SAS 1 NULL METER (60.1) must move to the left, indicating **10 ±2 microamp**.

NOTE

If null meter moves to the right, check extensible link wire connections (Task 7-88.1, step 7). If connector is wired correctly, replace self LVDT (Task 7-88.1).

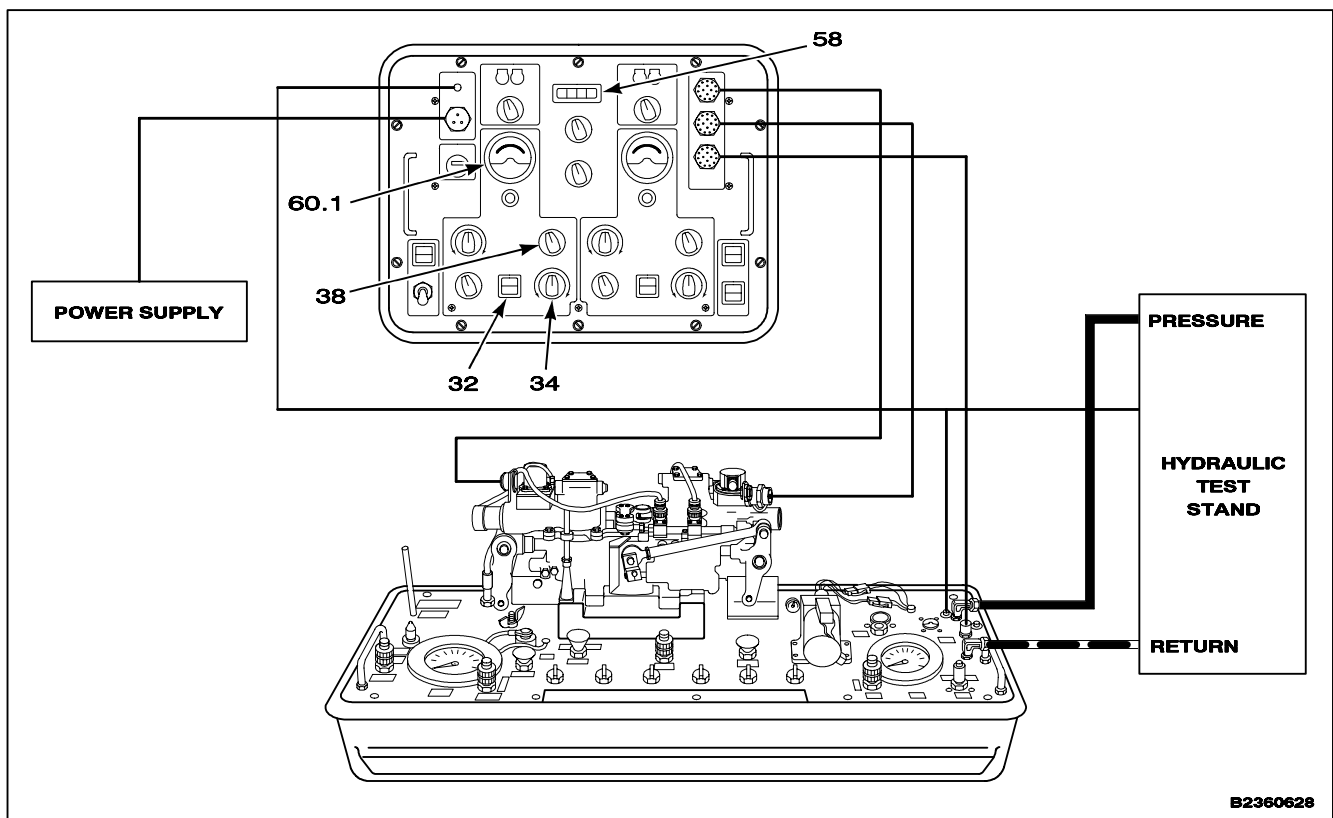

B2360628

- 59.13. Set SAS 1 LINK TEST switch (38) to CROSS FDBK. DVM (58) must indicate **0.50 ±0.03 volt**.

NOTE

If null meter moves to the right, check extensible link wire connections of the cross feedback transducer. If connector is wired correctly, replace cross feedback transducer (Task 7-88).

- 59.14. Set SAS 1 FEEDBACK SELECT switch (32) to CROSS. NULL METER (60.1) must decrease to **5 ±1 microamp**. If null meter moves to the right, the ILCA is out-of-phase.

NOTE

If null meter moves to the right, check extensible link wire connections of the No. 1 cross feedback transducer. If connector is wired correctly, replace cross feedback transducer (Task 7-88).

- 59.15. Turn SAS 1 VALVE CONTROL (34) to NULL.

- 59.16. Set SAS 1 FEEDBACK SELECT switch (32) to SELF.

- 59.17. Set SAS 1 LINK TEST switch (38) to SELF FDBK.

- 59.18. Turn SAS PRESS SYS 1 valve (3) to OFF.

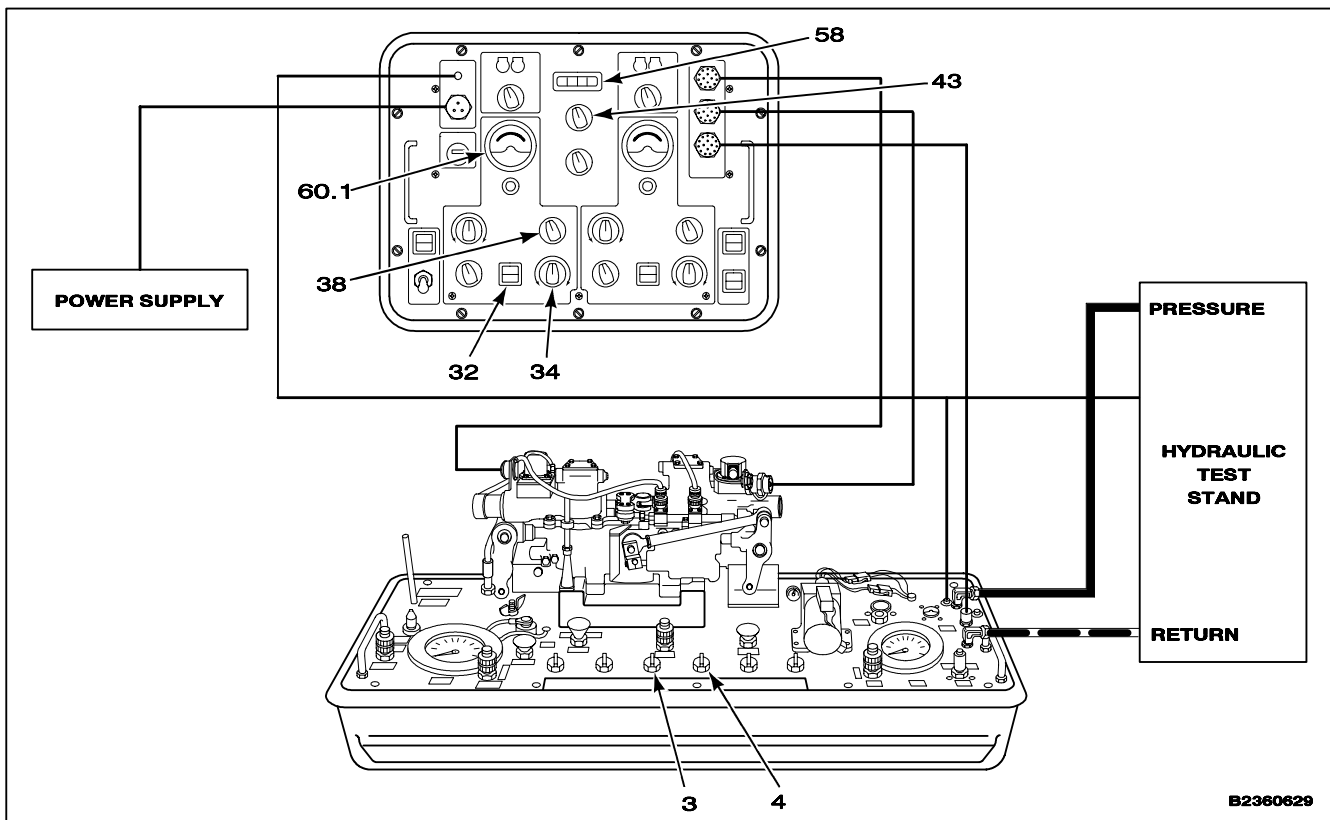

- 59.19. Set SYSTEM SELECT switch (43) to SAS 2.
- 59.20. Set SAS PRESS SYS 1 valve (3) to VENT.
- 59.20.1. Turn SAS PRESS SYS 2 valve (4) to PRESS.
- 59.21. Turn SAS 2 VALVE CONTROL (35) to EXTEND until DVM (58) indicates **1.0 volt**. SAS 2 NULL METER (60.2) must move to the right, indicating **10 ±2 microamp**. If null meter moves to the left, SAS 2 is out-of-phase.

NOTE

If null meter moves to the left, check extensible link wire connections (Task 7-88.1, step 7). If connector is wired correctly, replace self LVDT (Task 7-88.1).

- 59.22. Set SAS 2 LINK TEST switch (39) to CROSS FDBK. DVM (58) must indicate **0.50 ±0.03 volt**. If null meter moves to the left, the ILCA is out-of-phase.

NOTE

If null meter moves to the left, check extensible link wire connections for the cross feedback transducer. If connector is wired correctly, replace cross feedback transducer (Task 7-88).

- 59.23. Set SAS 2 FEEDBACK SELECT switch (33) to CROSS. NULL METER (60.2) must decrease to **5 ±1 microamp**. If null meter moves to the left, SAS 2 ILCA is out-of-phase.

NOTE

If null meter moves to the left, check extensible link wire connection for the cross feedback transducer. If connector is wired correctly replace cross feedback transducer (Task 7-88).

- 59.24. Set SAS 2 FEEDBACK SELECT switch (33) to SELF.

- 59.25. Set SAS 2 LINK TEST switch (39) to SELF.

- 59.26. Turn SAS 2 VALVE CONTROL (35) to RETRACT until DVM (58) indicates **1.0 volt**. SAS 2 NULL METER (60.2) must move to the left, indicating **10 ±2 microamp**.

NOTE

If null meter moves to the right, check extensible link wire connections (Task 7-88.1, step 7). If connector is wired correctly, replace self LVDT (Task 7-88.1).

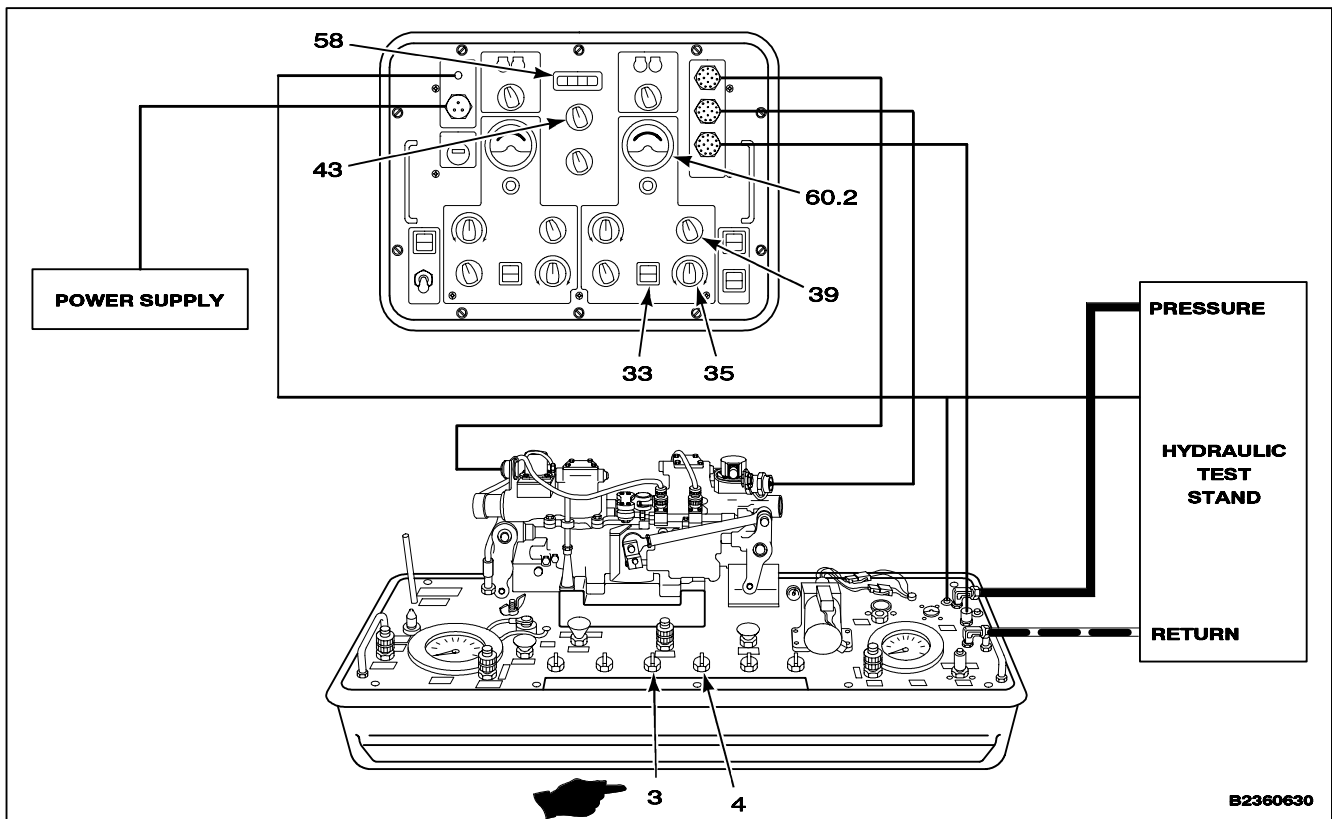

B2360630

59.27. Set SAS 2 LINK TEST switch (39) to CROSS FDBK. DVM (58) must indicate **0.50 ±0.03 volt**.

NOTE

If null meter moves to the right, check extensible link wire connections of cross feedback transducer. If connector is wired correctly, replace cross feedback transducer (Task 7-88).

59.28. Set SAS 2 FEEDBACK SELECT switch (33) to CROSS. NULL METER (60.2) must decrease to **5 ±1 microamp**. If null meter moves to the right, SAS 2 ILCA is out-of-phase.

NOTE

If null meter moves to the right, check extensible link wire connections of cross feedback transducer. If connector is wired correctly replace cross feedback transducer (Task 7-88).

59.29. Turn SAS 2 VALVE CONTROL (35) to NULL.

59.30. Repeat Tests 2, 3, 4, and 5, if LVDT was changed.

59.31. If no further testing is required, perform normal shutdown (TM 55-4920-428-13).

END NO. 1 AND NO. 2 EXTENSIBLE LINK PHASE TEST (SPARE)

FOLLOW-ON MAINTENANCE:

Manual cycling test (ALL).

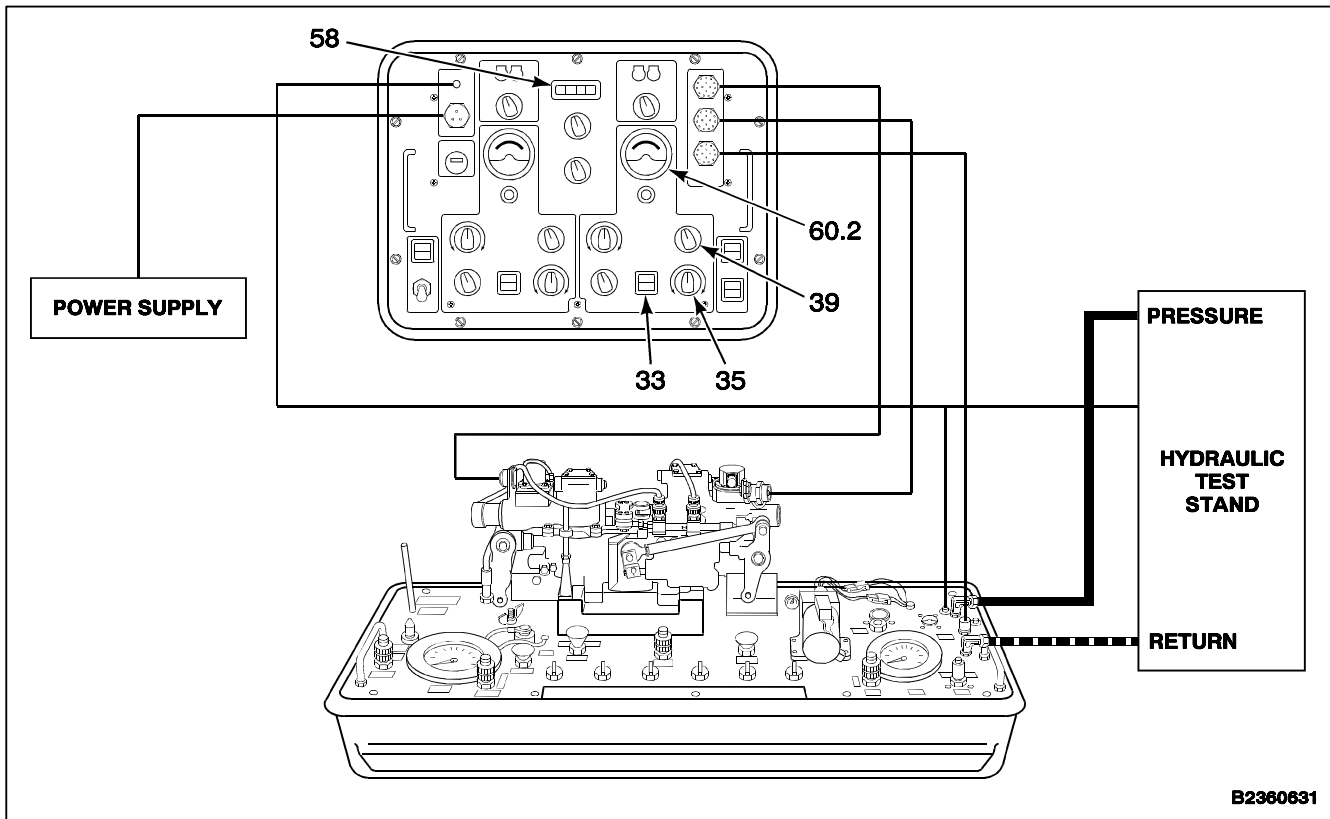

TEST 6

MANUAL CYCLING TEST (ALL)

- 60. Perform steps 1 thru 40. Check initial control and valve settings in steps 22 and 23.
- 61. Set electrical unit as follows:
 - a. Power switch (29) ON.
 - b. SOLENOID SHUTOFF switch (44) to OPEN.
- 61.1. Set hydraulic unit controls as follows:
 - a. Check RETURN SHUTOFF valve (47) is fully OPEN.
 - b. RETURN SYS 1 valve (5) to RETURN.
 - c. RETURN SYS 2 valve (6) to RETURN.
 - d. SOLENOID VALVE (53) to OPEN.
 - e. Slowly turn HIGH PRESS REGULATOR valve (52) towards INCREASE until HIGH PRESS gauge (13) indicates **1500 psi**.
 - f. ILCA PRESS SYS 1 and SYS 2 valve (1 and 2) to PRESS.
- g. Slowly turn HIGH PRESS SHUTOFF valve (51) to OPEN.
- 62. Manually move input arm (61) through full cycle. Check for the following:
 - a. No leakage from relief valve (62) on No. 1 or No. 2 system.

NOTE

If relief valve leaks perform Test 16 (Task 7-98).

NOTE

If binding is felt, ship ILCA to next level of maintenance.

NOTE

If leakage is present, record location and rate and perform Tests 12, 13, 15, 17, and 18 (Task 7-98).

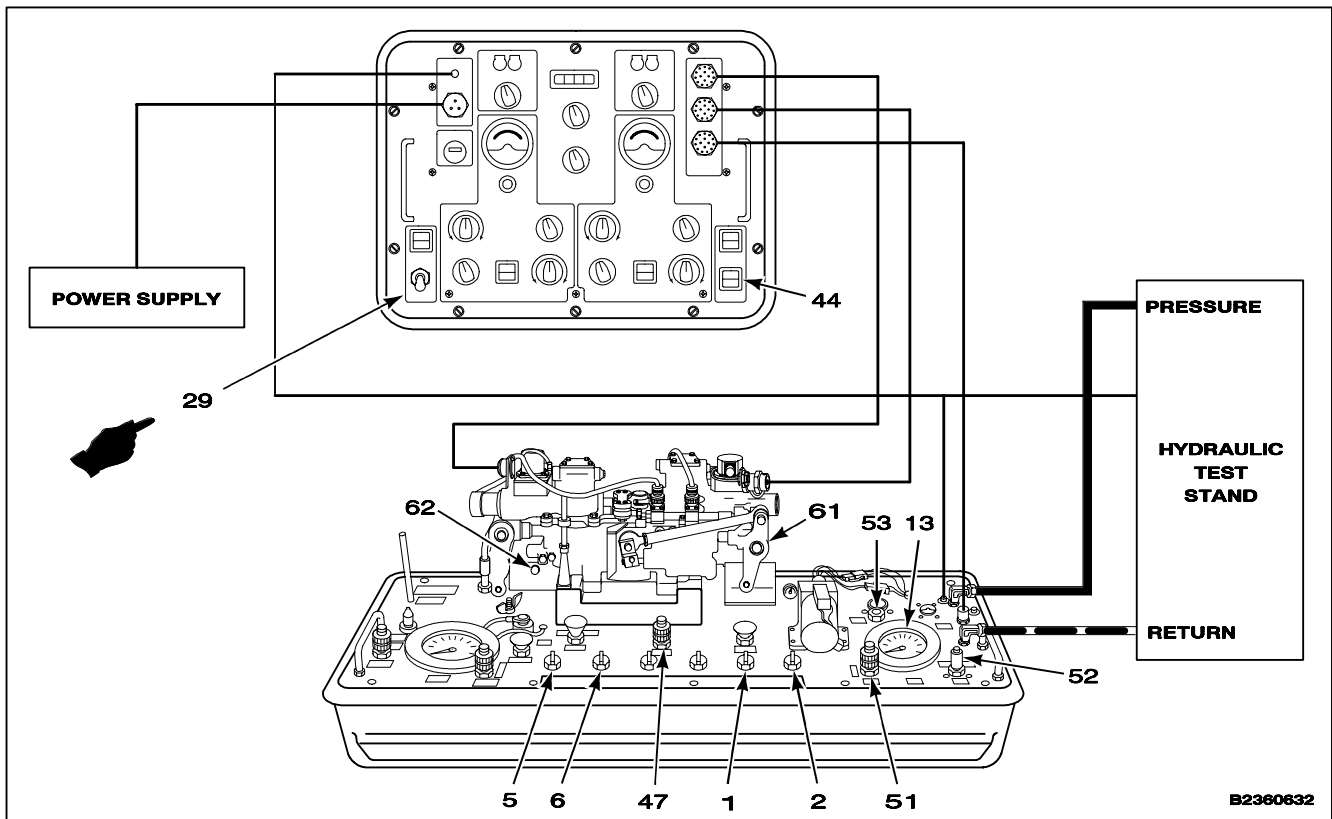

63. Remove pin (63) from cycle motor linkage (64). Position linkage in input arm (61).

64. Remove PIN 1 (65) from stowage. Install PIN 1 in arm (61) and linkage (64).

NOTE

Bring cycle motor arm bearing into alignment with input arm from below.

65. Press CYCLE MOTOR switch (45) to ON.

NOTE

Motor runs at about **20 cycles per minute**. **Fifty cycles** take about **2.5 minutes**.

66. Check for leaks at external dynamic seal (66). Leaks shall not exceed **1 drop in 50 cycles**.

67. Press CYCLE MOTOR switch (45) to OFF.

68. Remove and stow PIN 1 (65) and linkage (64). Install pin (63) in linkage.

69. Set ILCA PRESS SYS 2 valve (2) to VENT, then OFF.

70. Manually move input arm (61) through full cycle. Check for the following:

- a. No leaks from relief valve (62) on No. 1 or No. 2 system.
- b. No binding throughout full cycle of input arm (61).
- c. No static leaks.

NOTE

If any malfunctions appear during test steps 70a thru c, go to steps 62a thru c.

71. Set ILCA PRESS SYS 2 valve (2) to PRESS.

72. Set ILCA PRESS SYS 1 valve (1) to VENT, then OFF.

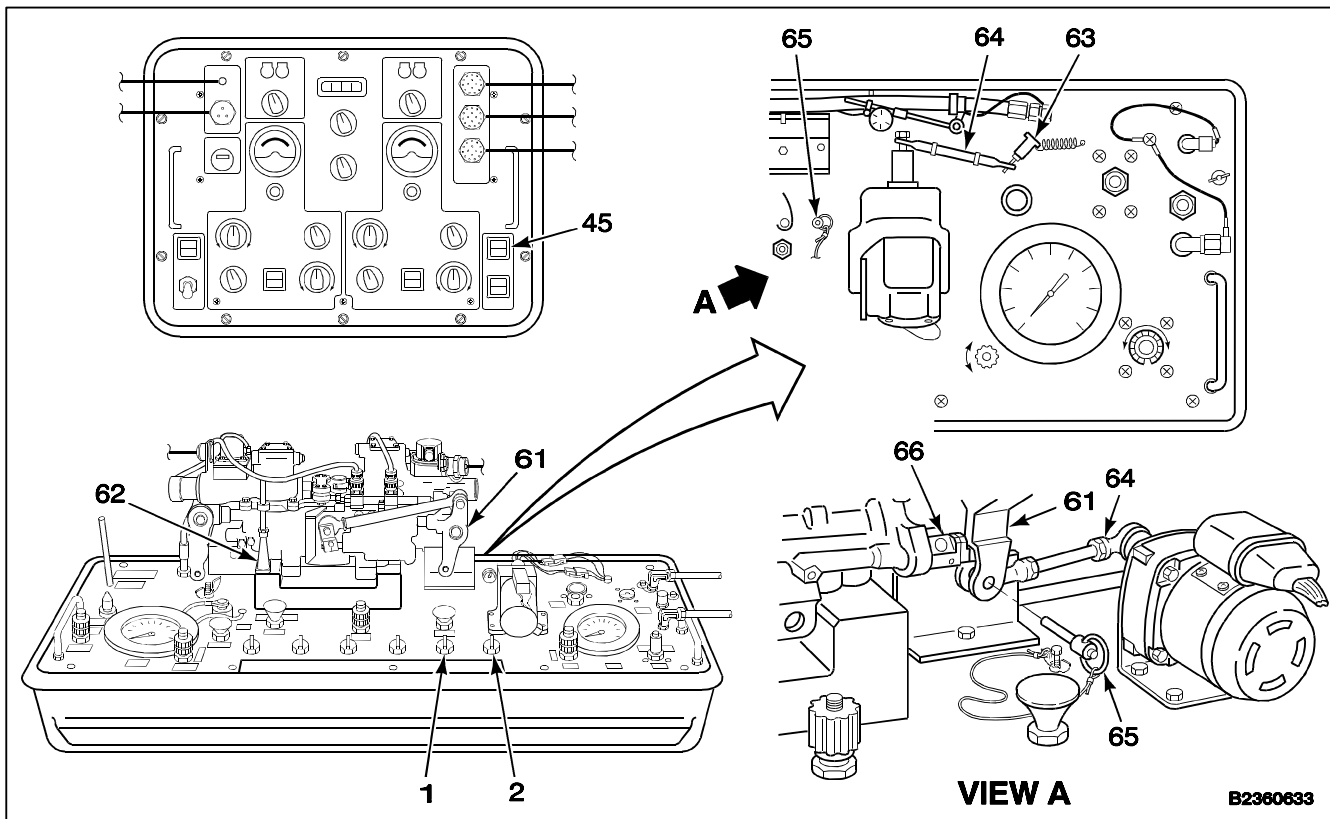

73. Manually move input arm (61) through full cycle. Check for the following:

- a. No leaks from relief valve (62) on No. 1 or No. 2 system.
- b. No binding throughout full cycle of input arm (61).
- c. No static leaks.

NOTE

If any malfunctions appear during test steps 73a thru c, go to steps 62a thru c.

74. Set ILCA PRESS SYS 1 valve (1) to PRESS.

75. Manually move input arm (61) through full cycle. Check for the following:

- a. No leaks from relief valve (62) on No. 1 or No. 2 system.
- b. No binding throughout full cycle of input arm (61).
- c. No static leaks.

NOTE

If any malfunctions appear during test steps 75a thru c, go to steps 62a thru c.

76. Set hydraulic unit controls as follows:

- a. HIGH PRESS REGULATOR valve (52) to full DECREASE.
- b. HIGH PRESS SHUTOFF valve (51) to CLOSE.
- c. ILCA PRESS SYS 1 valve (1) and ILCA PRESS SYS 2 valve (2) to VENT.

77. Press and hold HIGH PRESS RELIEF VALVE (67) and LOW PRESS RELIEF VALVE (68) for **15 seconds**. Release valves.

78. Set ILCA PRESS SYS 1 valve (1). ILCA PRESS SYS 2 valve (2), RETURN SYS 1 valve (5) and RETURN SYS 2 valve (6) to OFF.

79. Set SOLENOID VALVE (53) to CLOSED.

80. Press SOLENOID SHUTOFF switch (44) to CLOSE.

END OF MANUAL CYCLING TEST

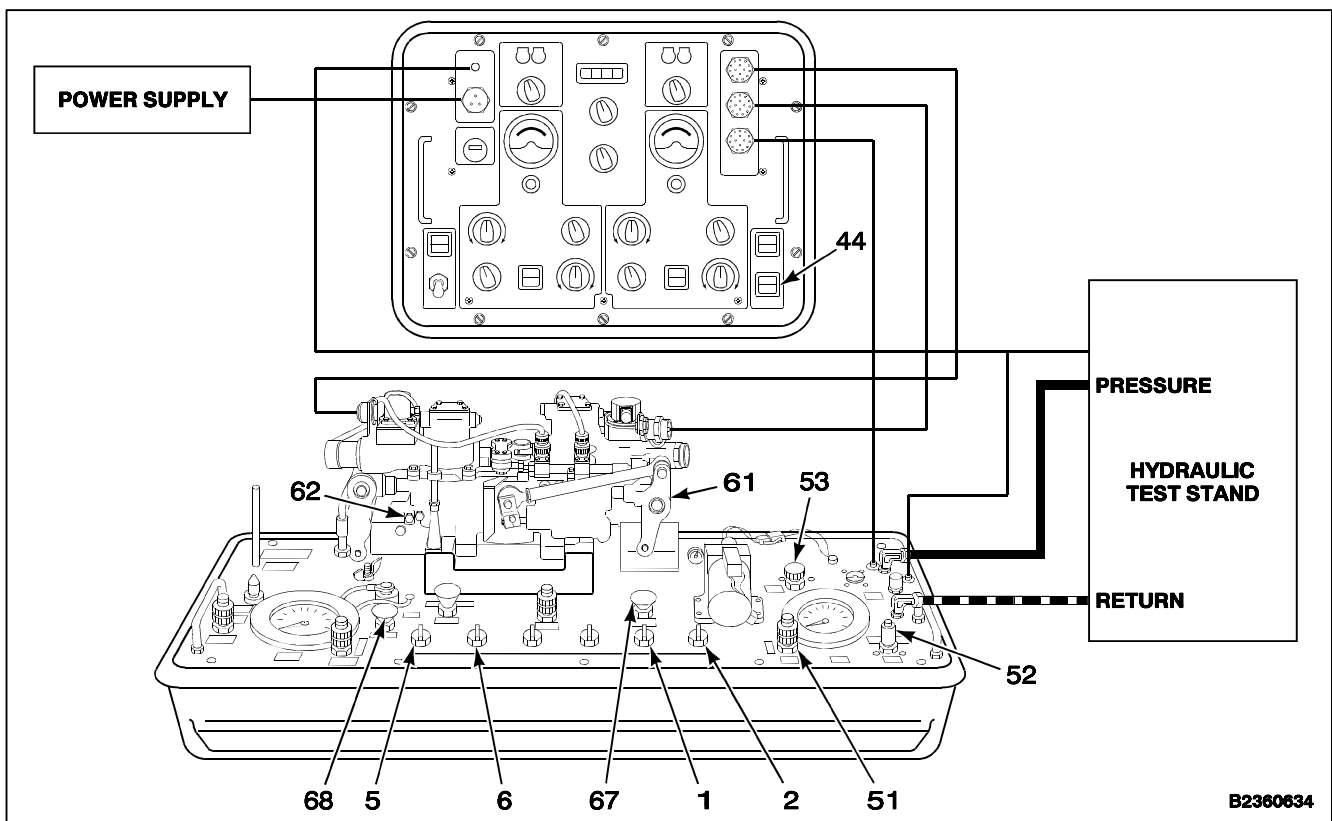

TEST 7

CYLINDER STROKE TEST (ALL)

- 81. Perform steps 1 thru 40. Check initial control and valve settings in steps 22 and 23.
- 82. Set electrical and hydraulic unit controls as follows:
 - a. Check RETURN SHUTOFF valve (47) is fully OPEN.
 - b. SOLENOID SHUTOFF switch (44) to OPEN.
 - c. SOLENOID valve (53) to OPENED.
 - d. RETURN SYS 1 valve (5) and RETURN SYS 2 valve (6) to RETURN.

- e. Slowly turn HIGH PRESS REGULATOR valve (52) towards INCREASE for a reading of **1500 psi** on HIGH PRESS gauge (13).
- f. ILCA PRESS SYS 1 valve (1) and ILCA PRESS SYS 2 valve (2) to PRESS.

WARNING

When turning valve, keep hands clear of input and output arms; otherwise, personnel injury can occur.

- 83. Slowly turn HIGH PRESS SHUTOFF valve (51) to full OPEN.

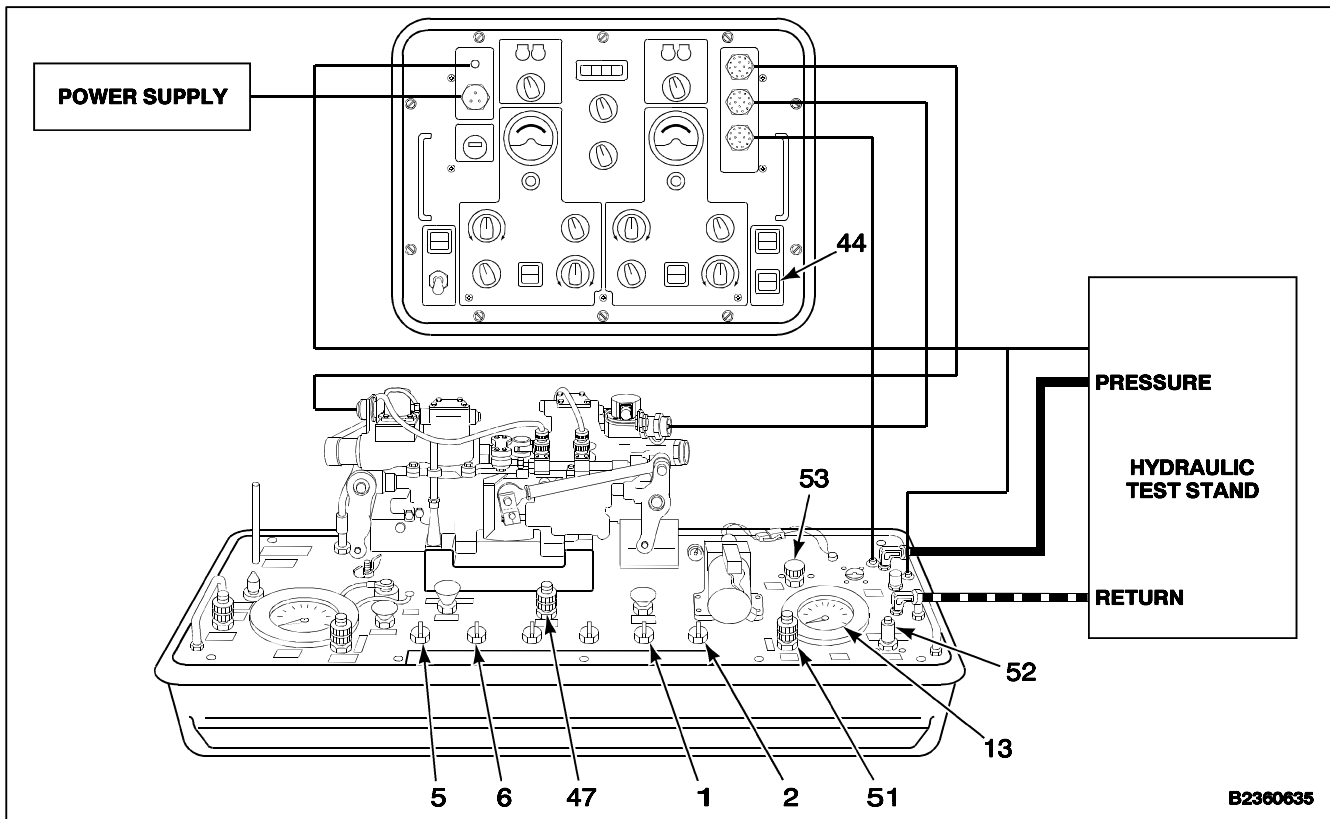

7-98 TEST PITCH, ROLL, YAW, OR THRUST INTEGRATED LOWER CONTROL ACTUATOR (ILCA) (AVIM) (Continued)

7-98

84. Remove PIN 2 (69) from stowage. Insert PIN 2 in input arm (61) through fixture (70).
85. Loosen rigging handle (71). Turn fixture (72) 90° clockwise. Tighten handle.
86. Remove PIN 3 (73) from stowage. Install PIN 3 in output arm (74) and through slot in fixture (72). Pin must slide freely.

NOTE

If PIN 3 (73) will not slide into the fixture slot, the ILCA must be rigged.

87. Remove and stow PIN 3 (73).
88. Loosen handle (71). Turn fixture (72) 90° counterclockwise to stowed position. Tighten handle.
89. Remove and stow PIN 2 (69).

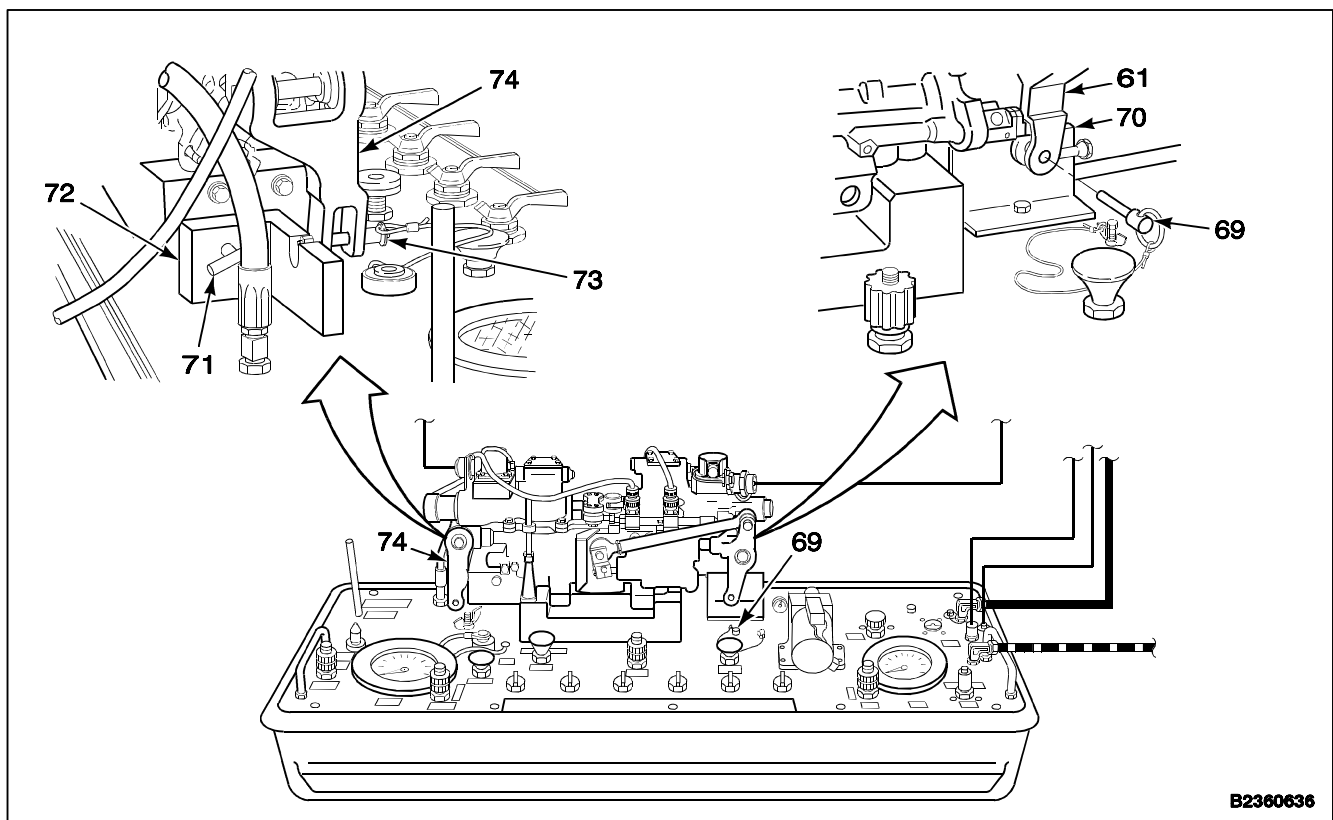

- 90. Remove PIN 3 (73) and bearing 145GS278-17 (75) from stowage. Install bearing in output arm (74).
- 91. Install PIN 3 (73) through bearing (75) and arm (74).
- 92. Set arm (74) to full retract stroke. Move arm (61) fully outward (EXTEND).
- 93. Install dial indicator (9) facing up, on post (76).

NOTE

Minimize axial motion when loading the dial indicator to reduce dial reading error due to shaft movement.

- 94. Set anvil of dial indicator (9) in full contact with bearing (75), and parallel with face of bearing. Align top of anvil with center of pin (73). Adjust outer ring of indicator to **zero**.

- 95. Preload dial indicator (9) to read **0.40 inch**.
- 96. Deleted.
- 97. Deleted.
- 98. Deleted.
- 99. Manually move input arm (61) to full retract position. Record dial indicator (9) reading.
- 100. Manually move input arm (61) to full extend position. Record dial indicator (9) reading.
- 101. Subtract step 100 reading from step 99 reading. Travel must be **4.469 to 4.531 inches**.

NOTE

If travel is not within limits, the ILCA must be rigged.

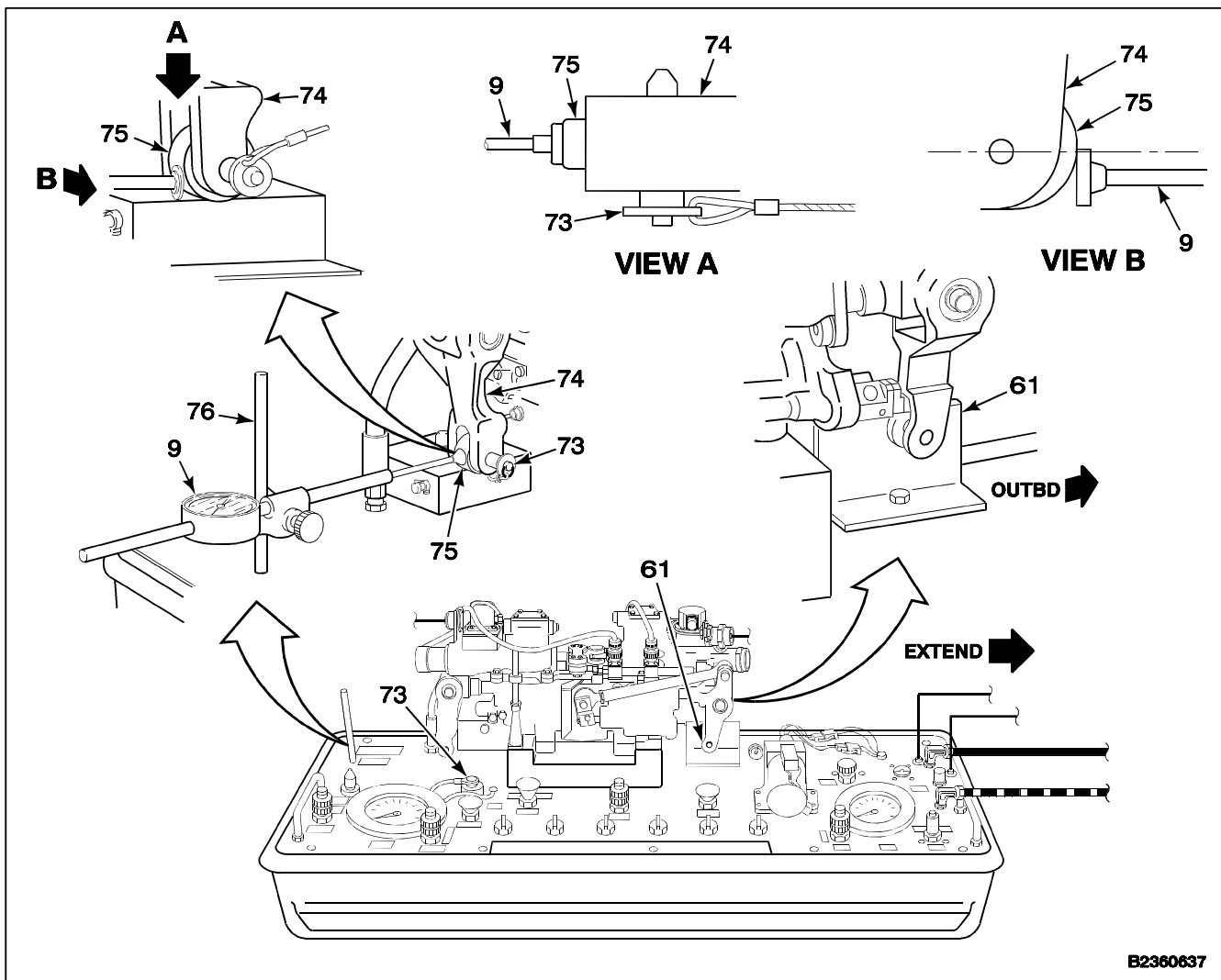

B2360637

102. Set electrical and hydraulic unit controls as follows:
- HIGH PRESS SHUTOFF valve (51) to CLOSE.
 - HIGH PRESS REGULATOR valve (52) to DECREASE.
 - SOLENOID valve (53) to CLOSED.
 - SOLENOID SHUTOFF switch (44) to CLOSED.
 - ILCA PRESS SYS 1 valve (1) and ILCA PRESS SYS 2 valve (2) to VENT.
103. Push and hold HIGH PRESS RELIEF valve (67) and LOW PRESS RELIEF VALVE (68) for 15 seconds.
104. Set ILCA PRESS SYS 1 valve (1), ILCA PRESS SYS 2 valve (2), RETURN SYS 1 valve (5), and RETURN SYS 2 valve (6) to OFF.
105. If not required for further testing, remove dial indicator (9).
- NOTE**
- Dial indicator used in Tests 7, 8, 9, 10, and 17.
106. Remove PIN 3 (73) and bearing from arm (74). Stow bearing and pin.
107. If no further testing is required, perform normal shutdown. (Refer to TM 55-4920-428-13.)
- END CYLINDER STROKE TEST**

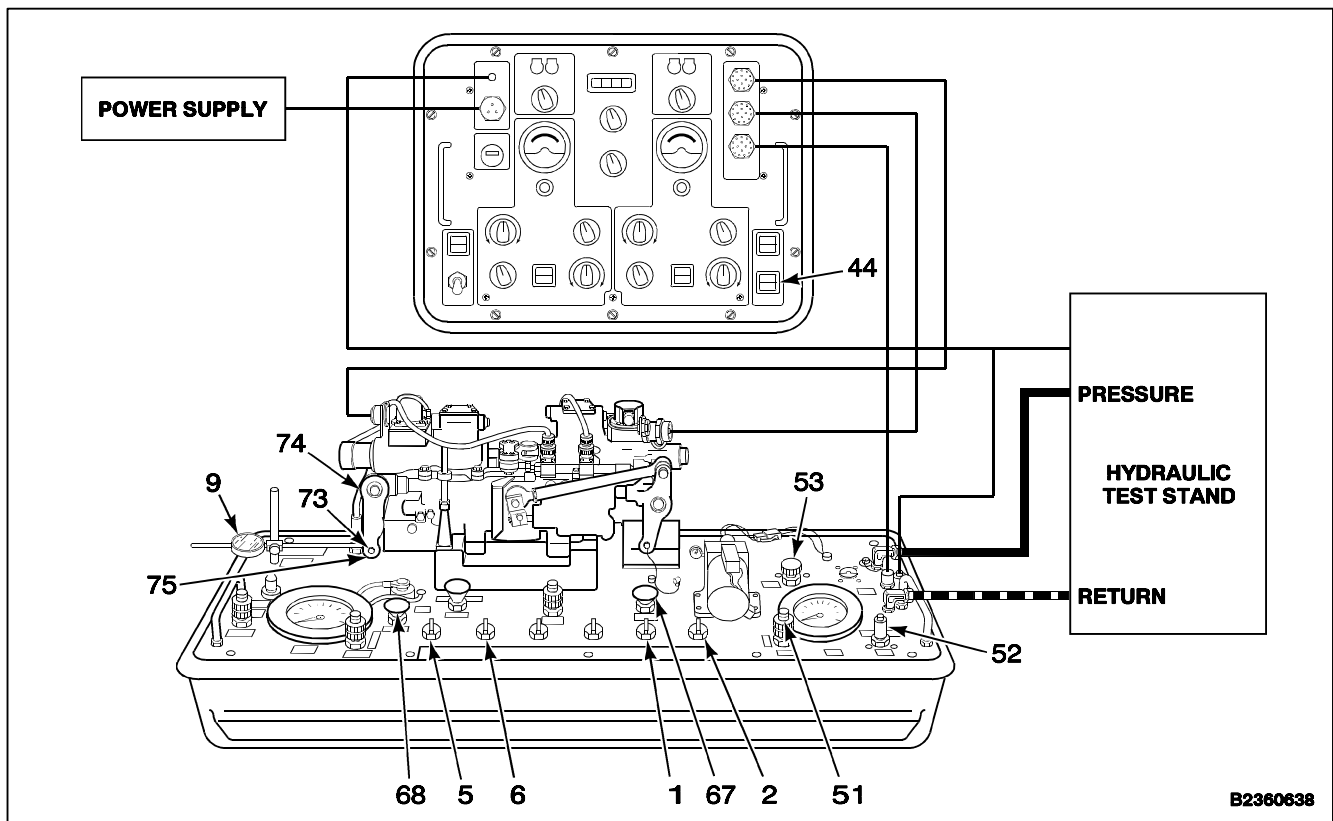

TEST 8

EXTENSIBLE LINK AUTHORITY TEST (SPARE)

108. Perform steps 1 thru 40. Check initial control and valve settings in steps 22 and 23.

NOTE

Tests 2, 3, 4, and 5 **MUST** be performed before this test.

109. Set electrical unit switches as follows:

- a. SYSTEM SELECT switch (43) to SAS 1.
- b. SAS 1 FUNCTION SELECT switch (30) to CLSD LOOP.
- c. SAS 1 LINK TEST switch (38) to SELF FDBK.
- d. SAS 1 FEEDBACK SELECT switch (32) to SELF.
- e. SAS 1 VALVE CONTROL (34) to NULL.
- f. SAS 1 SQ WAVE control (36) to MIN.

110. Set electrical and hydraulic unit controls as follows:

- a. Check RETURN SHUTOFF valve (47) is OPEN.
- b. RETURN SYS 1 valve (5) and RETURN SYS 2 valve (6) to RETURN.
- c. SOLENOID valve (53) to OPENED.
- d. SOLENOID SHUTOFF switch (44) to OPEN.
- e. Slowly turn HIGH PRESS REGULATOR valve (52) towards INCREASE until HIGH PRESS gauge (13) indicates **1500 psi**.
- f. ILCA PRESS SYS 1 valve (1). ILCA PRESS SYS 2 valve (2) to PRESS.
- g. Slowly turn HIGH PRESS SHUTOFF valve (51) to OPEN.

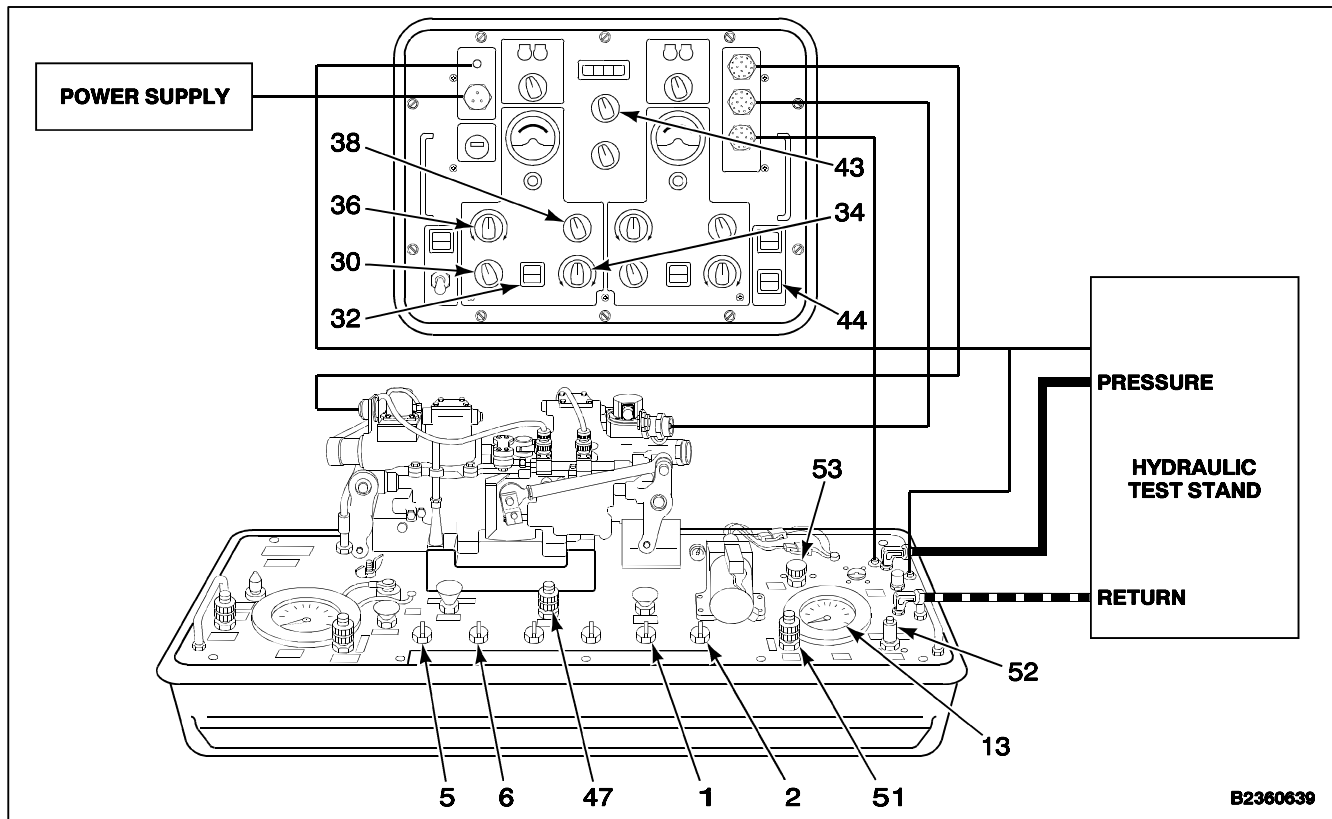

B2360639

7-98 TEST PITCH, ROLL, YAW, OR THRUST INTEGRATED LOWER CONTROL ACTUATOR (ILCA) (AVIM) (Continued)

- 110.1. Install PIN 2 (69) in input arm (61).
- 111. Perform steps 90 thru 95.
- 112. Set SAS PRESS SYS 1 valve (3) to PRESS.
- 113. Perform No. 1 link operational test as follows:
 - a. Slowly turn SAS VALVE CONTROL (34) to EXTEND. SAS 1 NULL METER (60.1) shall move to right.

NOTE

Extensible link piston will move in same direction as the valve control knob.

- b. Set FUNCTION SELECT switch (30) to HARDOVER EXTEND. Record reading indicated on DVM (58).

- c. Record reading indicated on indicator (9).
- d. Set SAS 1 LINK TEST switch (38) to CROSS FDBK. Set FEEDBACK SELECT switch (32) to CROSS. Record reading indicated on DVM (58).
- e. Set FUNCTION SELECT switch (30) to CLSD LOOP. SAS 1 NULL METER (60.1) shall move to the right.
- f. Slowly turn SAS 1 VALVE CONTROL (34) to RETRACT. SAS 1 NULL METER (60.1) shall move to the left.
- g. Set FUNCTION SELECT switch (30) to HARDOVER RETRACT. Record reading indicated on DVM (58).
- h. Record reading indicated on indicator (9).

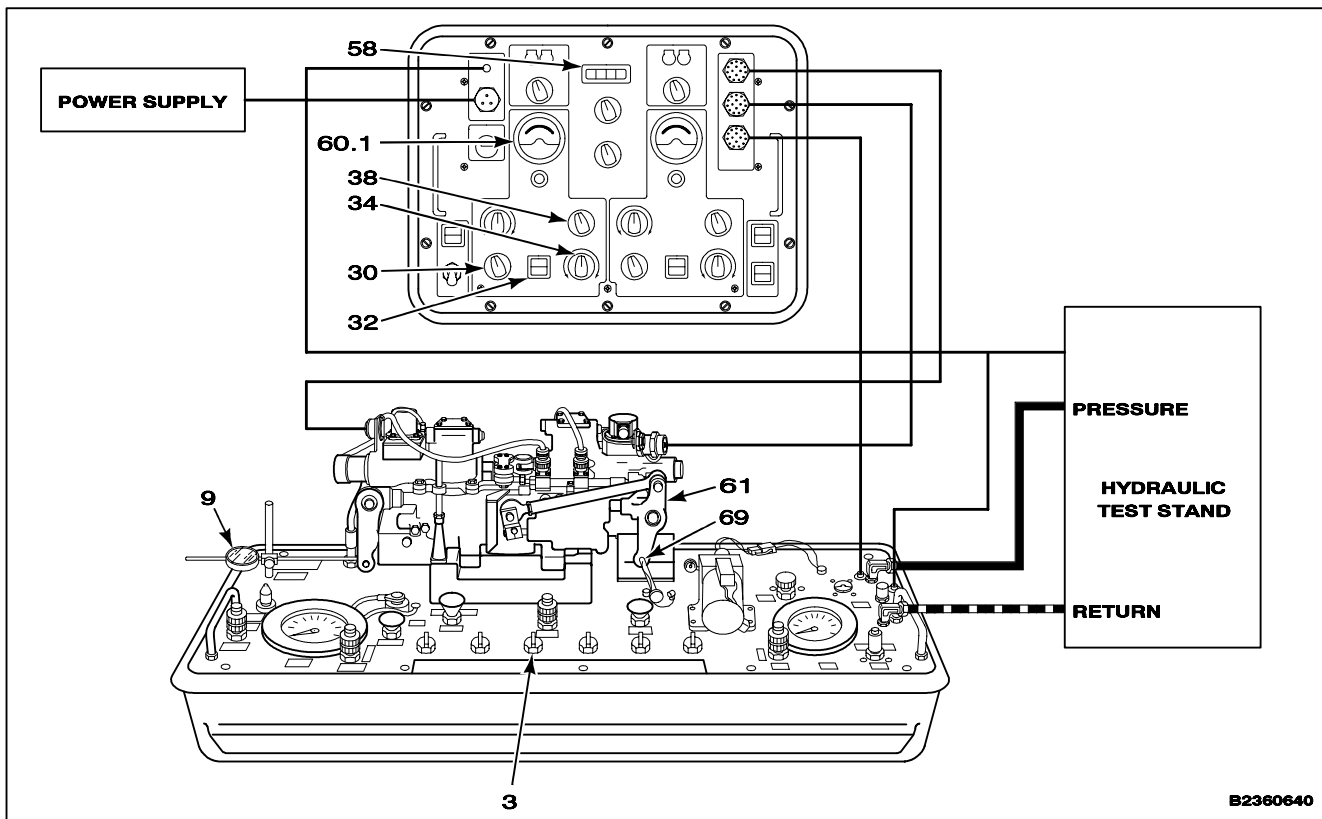

- i. Set SAS 1 LINK TEST switch (38) to SELF FDBK and FEEDBACK SELECT switch (32) to SELF. Record indication on DVM (58).
- j. Set FUNCTION SELECT switch (30) to CLSD LOOP. SAS 1 NULL METER (60.1) shall move to left.
- k. Subtract step h reading from step c reading. Travel shall be **0.62 to 0.74 inch**.

NOTE

If travel is not acceptable, and the Test (RED) authority covers are installed, replace the No. 1 extensible link.

- l. Check readings from steps b and j. Readings shall be **1.50 to 1.91 volts**.

NOTE

If self feedback LVDT is replaced, insure that Tests 2, 3, 4, and 5 were performed.

- m. Check readings from steps e and g. Readings shall be **0.75 to 0.96 volt**.

NOTE

Insure that Tests 2, 3, 4, and 5 were performed. If they were, replace the self feedback LVDT.

If both travel and voltages are incorrect, replace the servomotor assembly or extensible link.

- 114. Set SAS 1 VALVE CONTROL (34) to NULL.
- 115. Set SAS PRESS SYS 1 valve (3) to OFF.
- 116. Set electrical unit switches as follows:
 - a. SYSTEM SELECT switch (43) to SAS 2.
 - b. SAS 2 FUNCTION SELECT switch (31) to CLSD LOOP.
 - c. SAS 2 LINK TEST switch (39) to SELF FDBK.
 - d. SAS 2 FEEDBACK SELECT switch (33) to SELF.
 - e. SAS 2 VALVE CONTROL (35) to NULL.
 - f. SAS 2 SQ WAVE control (37) to MIN.
- 117. Set SAS PRESS SYS 2 valve (4) to PRESS.

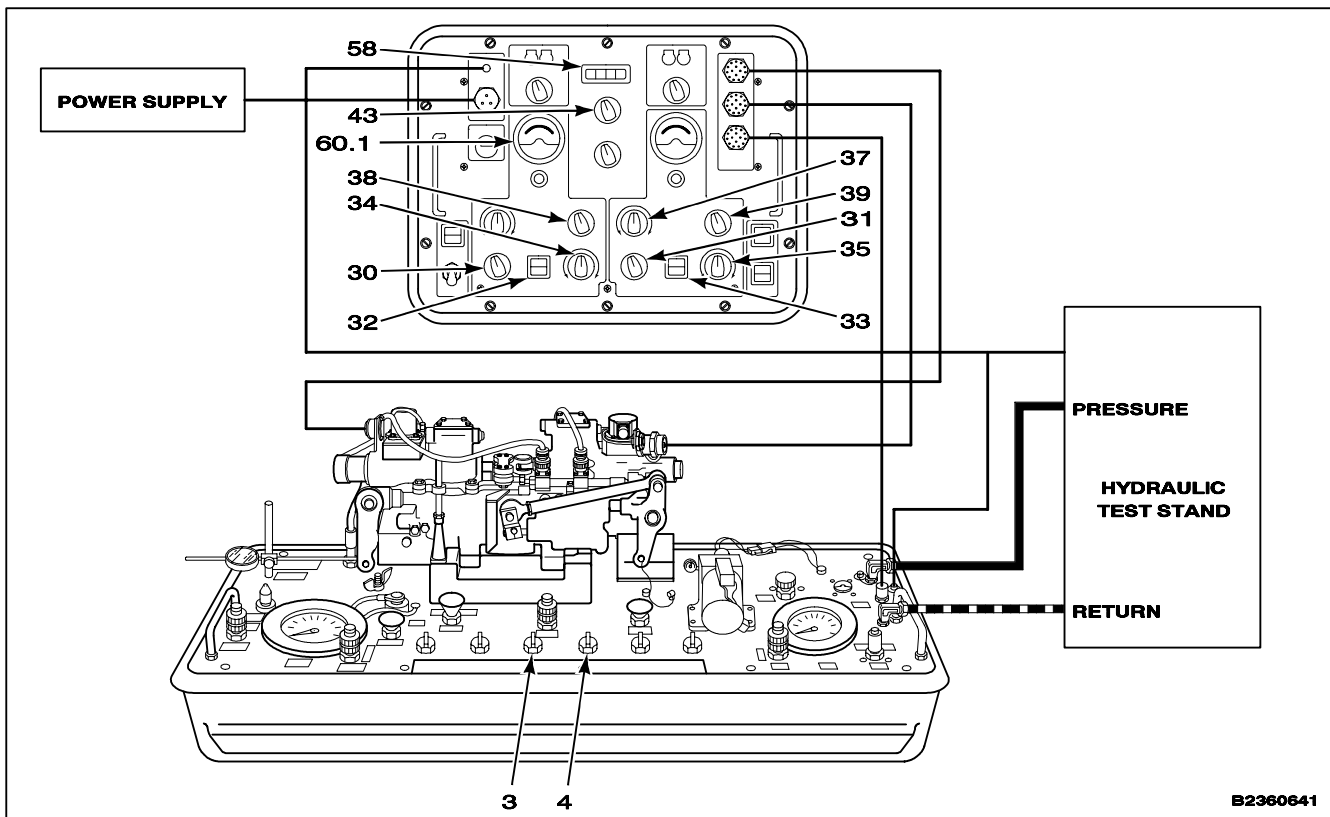

7-98 TEST PITCH, ROLL, YAW, OR THRUST INTEGRATED LOWER CONTROL ACTUATOR (ILCA) (AVIM) (Continued)

118. Perform No. 2 link operational test as follows:

- a. Slowly turn SAS 2 VALVE CONTROL (35) to EXTEND. SAS 2 NULL METER (60.2) shall read to the right.

NOTE

Output arm will move in same direction in relation to valve control position.

- b. Set FUNCTION SELECT switch (31) to HARDOVER EXTEND. Record reading indicated on DVM (58).
- c. Record reading indicated on indicator (9).
- d. Set SAS 2 LINK TEST switch (39) to CROSS FDBK and FEEDBACK SELECT switch (33) to CROSS.

- e. Record reading indicated on DVM (58). Set FUNCTION SELECT switch (31) to CLSD LOOP. SAS 2 NULL METER (60.2) shall read to right.
- f. Slowly turn SAS 2 VALVE CONTROL (35) to RETRACT. SAS 2 NULL METER (60.2) shall read to the left. Set FUNCTION SELECT switch (31) to HARDOVER.
- g. Record reading indicated on DVM (58).
- h. Record reading indicated on indicator (9).
- i. Set SAS 2 LINK TEST switch (39) to SELF FDBK and FEEDBACK SELECT switch (33) to SELF.
- j. Record reading indicated on DVM (58). Set FUNCTION SELECT switch (31) to CLSD LOOP. SAS 2 NULL METER (60.2) shall read to the left.

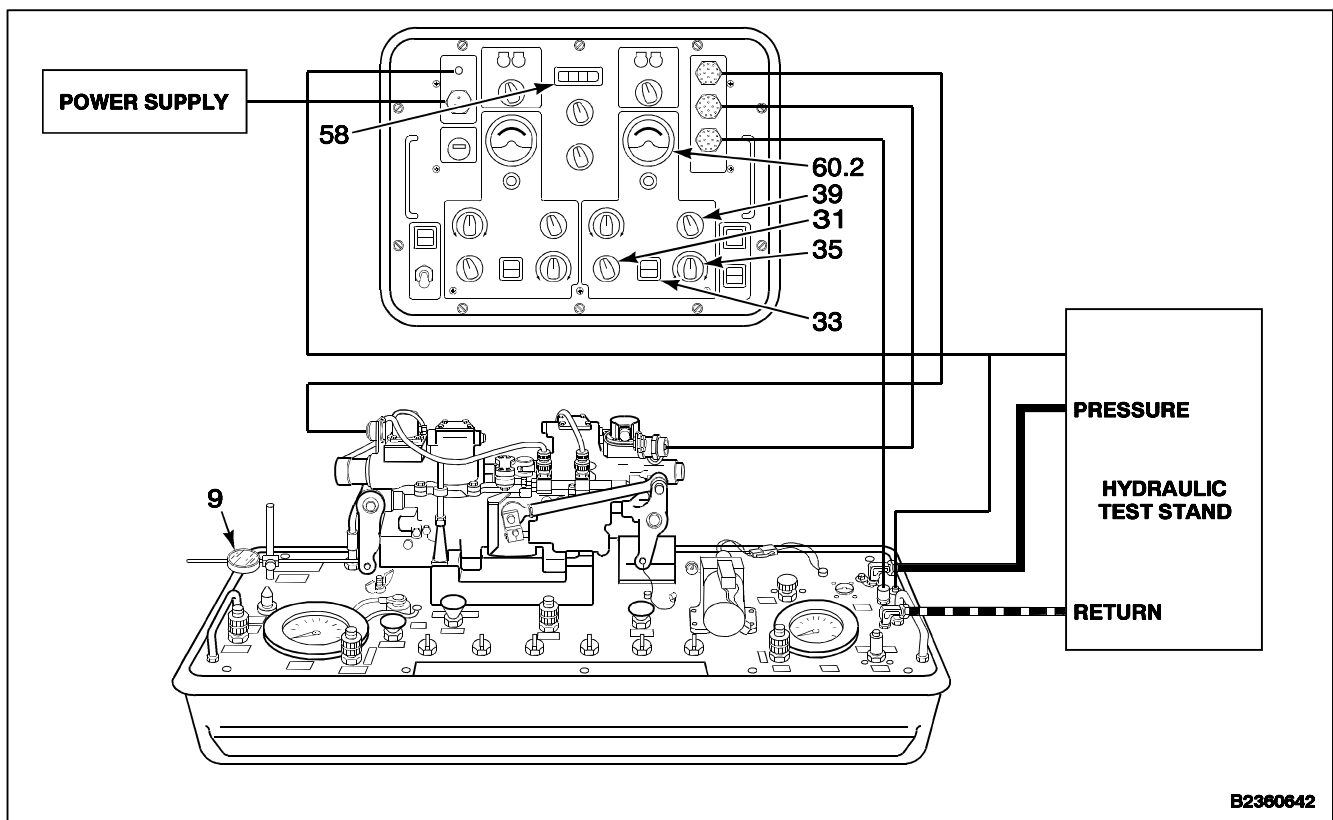

- k. Subtract step h reading from step c reading. Travel shall be **0.62 to 0.74 inch**.

NOTE

If travel is not acceptable, and the Test (RED) authority covers are installed, replace No. 2 extensible link.

- l. Check readings from steps b and j. Readings shall be **1.50 to 1.91 volts**.

NOTE

Insure Tests 2, 3, 4, and 5 were performed. If they were, replace self LVDT.

- m. Check readings from step e and g. Readings shall be **0.75 to 0.96 volt**.

NOTE

Insure Tests 2, 3, 4, and 5 were performed. If they were, replace self LVDT.

If both travel and voltages are incorrect, replace servomotor assembly or extensible link.

- 119. Perform dual extensible link operational test as follows:

- a. Set SAS PRESS SYS 1 valve (3) to PRESS.
- b. Set SAS 1 FUNCTION SELECT switch (30) to HARDOVER EXTEND. Set SAS 2 FUNCTION SELECT switch (31) to HARDOVER RETRACT.
- c. Set SYSTEM SELECT switch (43) to SAS 1.
- d. Set SAS 1 LINK TEST switch (38) to CROSS FDBK.
- e. Record reading indicated on DVM (58).

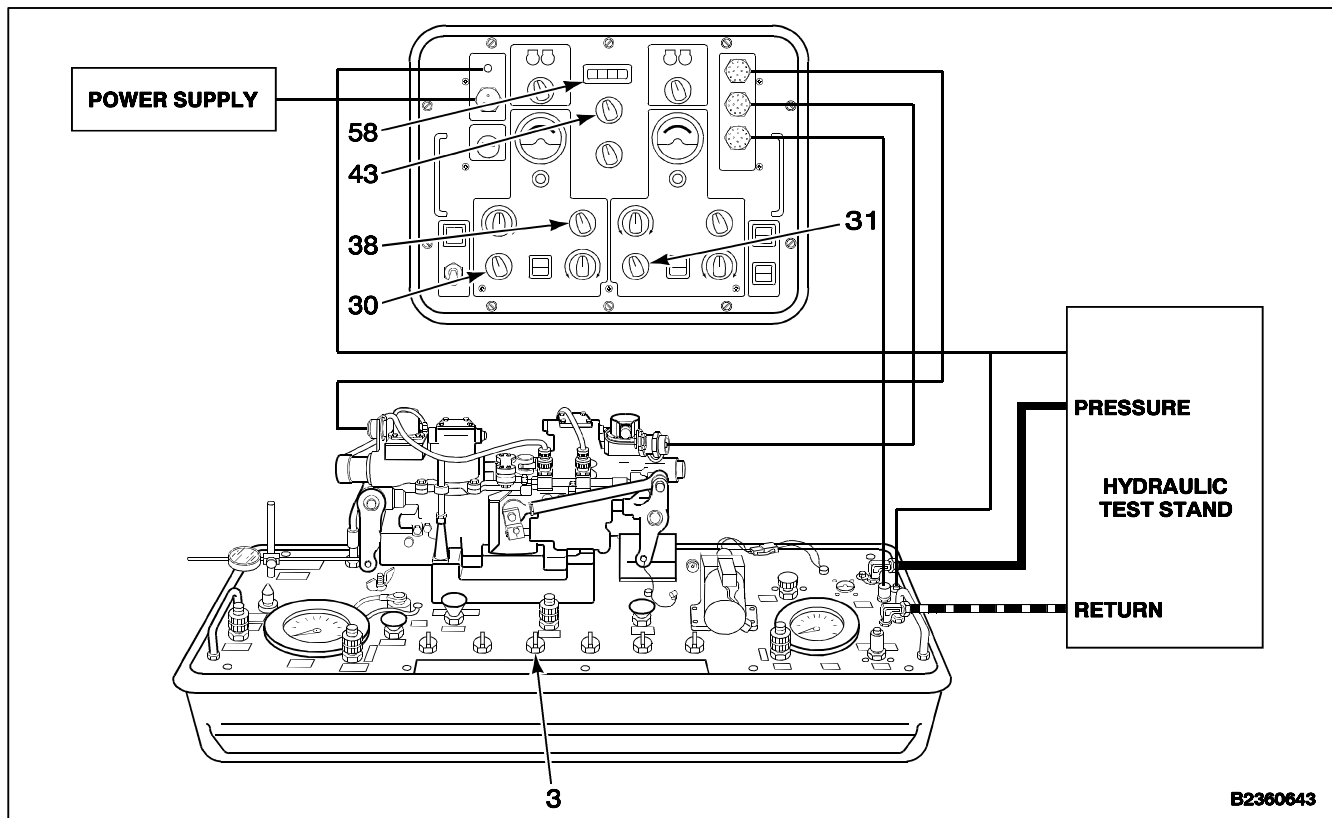

7-98 TEST PITCH, ROLL, YAW, OR THRUST INTEGRATED LOWER CONTROL ACTUATOR (ILCA) (AVIM) (Continued)

- | | |
|-----------------------------------------------------------------------------------------------------------------------------------------------------------------------------------------------------------------------------------------------------------------------------------------------------------------------------------------------------------------------------------------------------------------------------------------------------|----------------------------------------------------------------------------------------------------------------------------------------------------------------------------------------------------------------------------------------------------------------------------------------------------------------------------------------------------------------------------------------------------------------------------------------------------------------------------------------------|
| <ul style="list-style-type: none"> f. Set SYSTEM SELECT switch (43) to SAS 2. g. Set SAS 2 LINK TEST switch (39) to CROSS FDBK. h. Record reading indicated on DVM (58). i. Record reading indicated on indicator (9). j. Set SAS 1 FUNCTION SELECT switch (30) to HARDOVER RETRACT. Set SAS 2 FUNCTION SELECT switch (31) to HARDOVER EXTEND. k. Record reading indicated on DVM (58). | <ul style="list-style-type: none"> l. Set SYSTEM SELECT switch (43) to SAS 1. m. Set SAS 2 FEEDBACK SELECT switch (33) to CROSS. n. Record reading indicated on DVM (58). o. Record reading indicated on indicator (9). p. Check readings from steps i and o. The difference between the readings shall be 1.24 to 1.48 inches. q. Check readings from steps e, h, k, and n. Readings shall be 1.50 to 1.91 volts. |
|-----------------------------------------------------------------------------------------------------------------------------------------------------------------------------------------------------------------------------------------------------------------------------------------------------------------------------------------------------------------------------------------------------------------------------------------------------|----------------------------------------------------------------------------------------------------------------------------------------------------------------------------------------------------------------------------------------------------------------------------------------------------------------------------------------------------------------------------------------------------------------------------------------------------------------------------------------------|

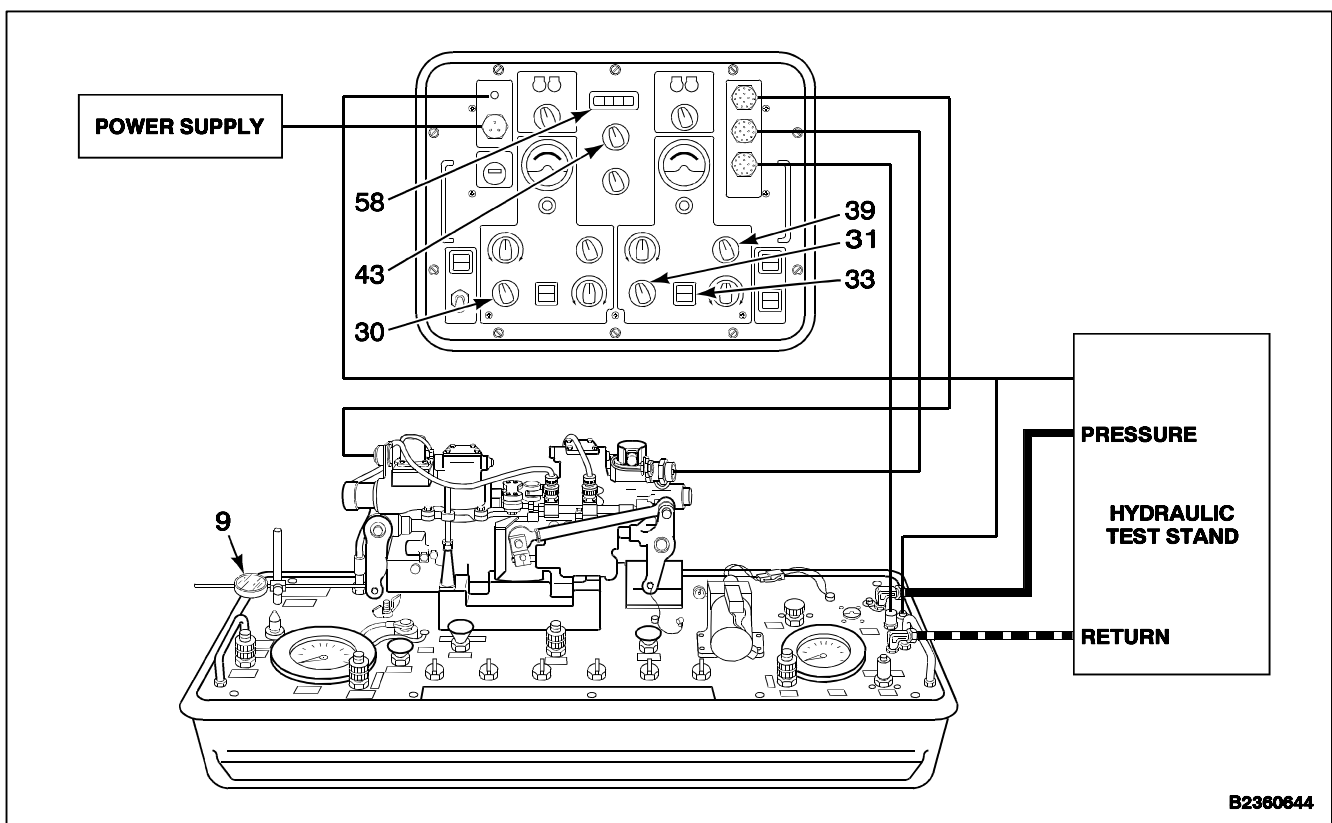

- 120. Set SAS PRESS SYS 1 valve (3) and SAS PRESS SYS 2 valve (4) to VENT.
- 121. Set SAS 1 FUNCTION SELECT switch (30) and SAS 2 FUNCTION SELECT switch (31) to BALANCE.
- 122. Remove PIN 2 (69) from input arm (61). Stow pin.
- 123. Set hydraulic unit controls as follows:
 - a. HIGH PRESS REGULATOR valve (52) to MAXIMUM DECREASE.
 - b. SOLENOID SHUTOFF switch (44) to CLOSED.
 - c. SOLENOID valve (53) to CLOSED.
 - d. ILCA PRESS SYS 1 valve (1) and ILCA PRESS SYS 2 valve (2) to VENT.
 - e. Push and hold HIGH PRESS RELIEF VALVE (67) and LOW PRESS RELIEF VALVE (68) for **15 seconds**. Check HIGH PRESS gauge (13) indicates **0 psi**.
- f. HIGH PRESS SHUTOFF valve (51) to CLOSE.
- g. ILCA PRESS SYS 1 valve (1), ILCA PRESS SYS 2 valve (2), SAS PRESS SYS 1 VALVE (3), SAS PRESS SYS 2 VALVE (4), RETURN SYS 1 valve (5), and RETURN SYS 2 valve (6) to OFF.
- 124. If not needed for further testing, remove indicator (9).

NOTE

Dial indicator is used in Tests 7, 8, 9, 10, and 17.

- 125. If no further testing is required, perform normal shutdown. (Refer to TM 55-4920-428-13.)

END EXTENSIBLE LINK AUTHORITY TEST

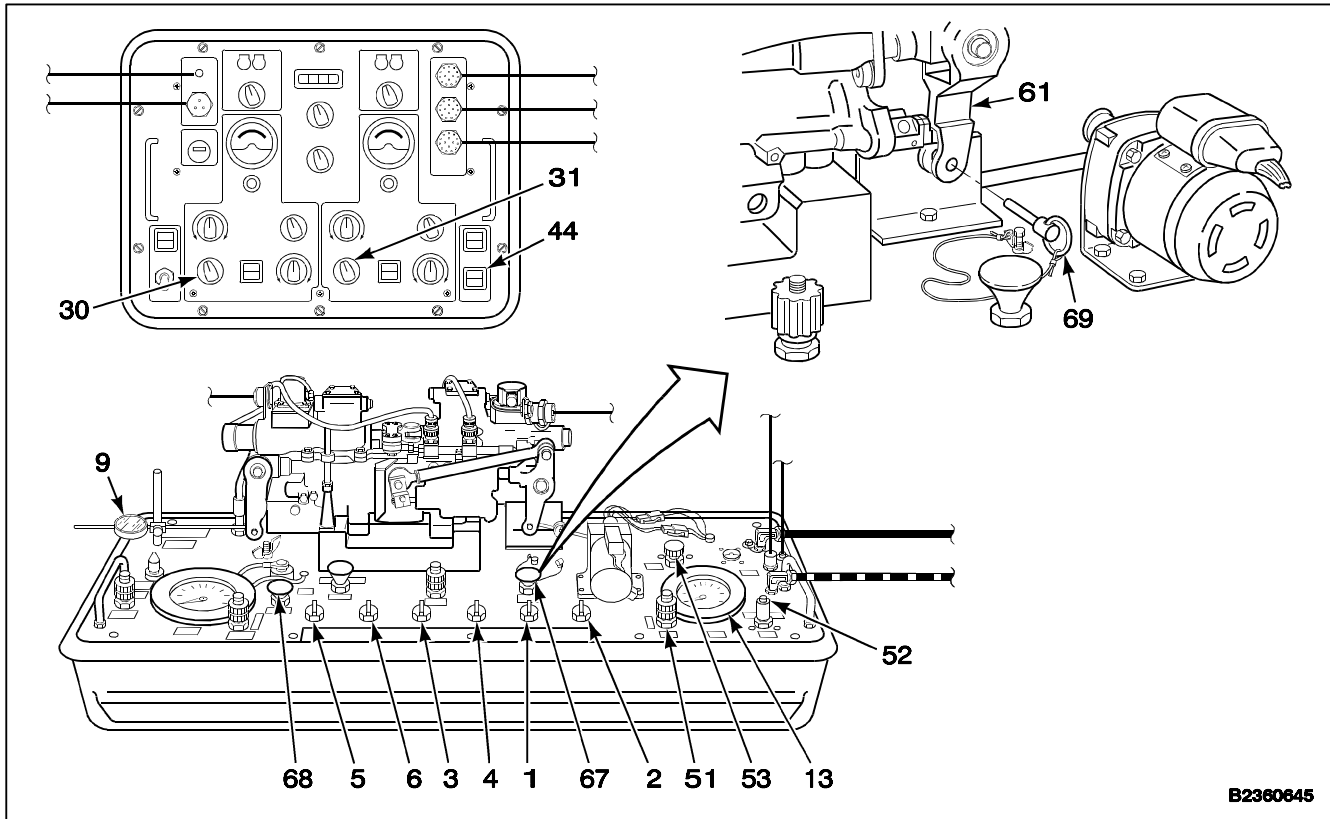

B2360645

TEST 9

STATIC DEADBAND TEST (ALL)

126. Perform steps 1 thru 40. Check initial control and valve settings in steps 22 and 23.

NOTE

Tests 2, 3, 4, and 5 **MUST** be performed before this test.

127. Set electrical and hydraulic unit controls as follows:

- a. Check RETURN SHUTOFF valve (47) is OPEN.
- b. RETURN SYS 1 valve (5) and RETURN SYS 2 valve (6) to RETURN.
- c. SOLENOID valve (53) to OPENED.
- d. SOLENOID SHUTOFF switch (44) to OPEN.

- e. Slowly turn HIGH PRESS REGULATOR valve (52) towards INCREASE until HIGH PRESS gauge (13) indicates **1500 psi**.
 - f. ILCA PRESS SYS 1 valve (1) and ILCA PRESS SYS 2 valve (2) to PRESS.
 - g. Slowly turn HIGH PRESS SHUTOFF valve (51) to full OPEN.
128. Manually hold position of input arm (61). Position dial indicator (77) against arm.
129. If dial indicator (9) is not installed, install it. (Refer to steps 93 thru 95.)
130. SAS PRESS SYS 1 valve (3) and SAS PRESS SYS 2 valve (4) to PRESS.
131. Set SAS 1 FUNCTION SELECT switch (30) and SAS 2 FUNCTION SELECT switch (31) to BALANCE.

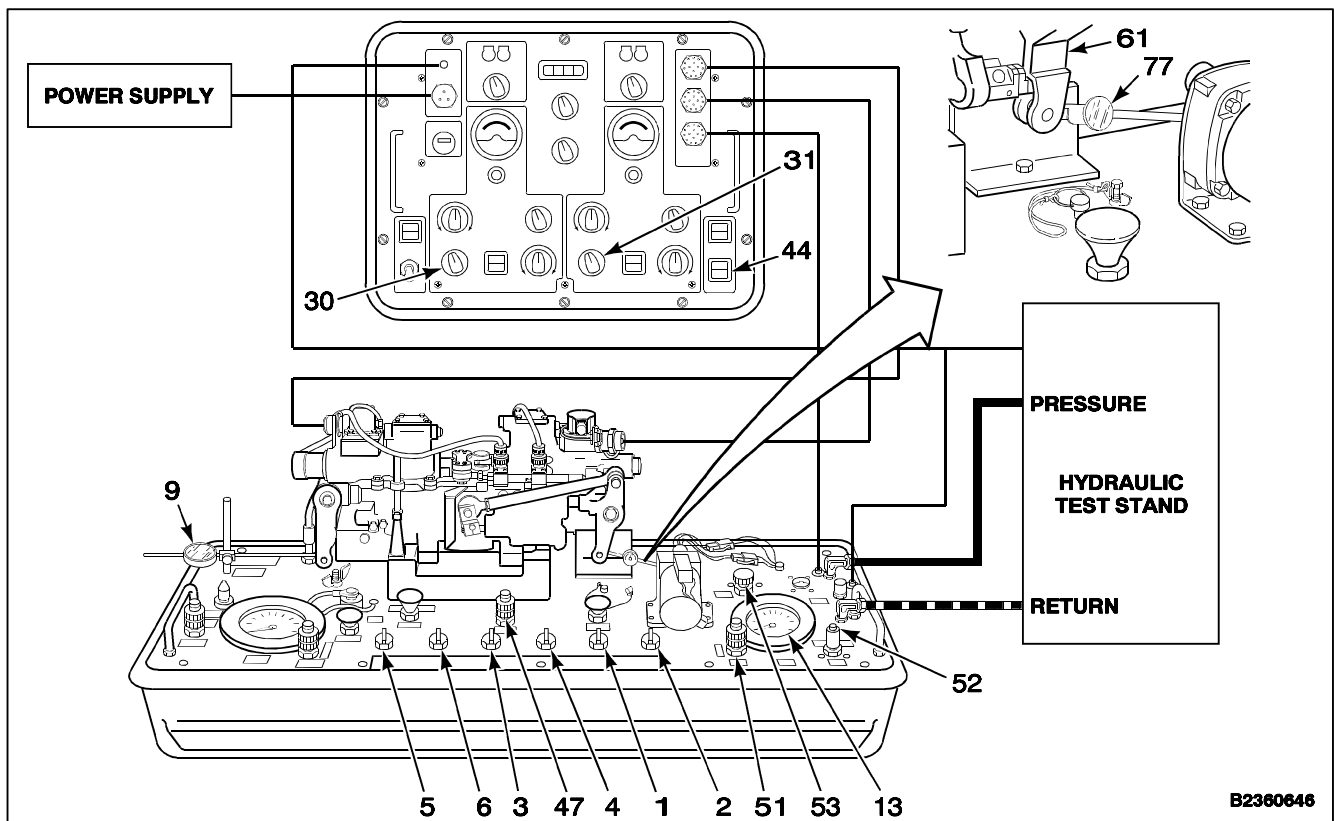

B2360646

NOTE

Do not move input arm to extreme position.

- 132. Manually move input arm (61) outward until pointer of indicator (77) moves **0.030 inch (1 complete turn)**. Reposition dial indicator (77) and set to **0**. Note reading on indicator (9).
- 133. Manually move input arm (61) to left **0.006 inch maximum** as indicated on dial indicator (77). Dial indicator (9) shall indicate a reversal of motion.
- 134. Set SAS PRESS SYS 1 valve (3) and SAS PRESS SYS 2 valve (4) to VENT and then to OFF.
- 135. Manually move input arm (61) to right. Reset dial indicator (77) to **0**. Note reading indicated on dial indicator (9).
- 136. Manually move input arm (61) left **0.010 inch** as indicated on dial indicator (77) (**0.030 inch** when testing thrust ILCA). Dial indicator (9) shall indicate a reversal of motion.

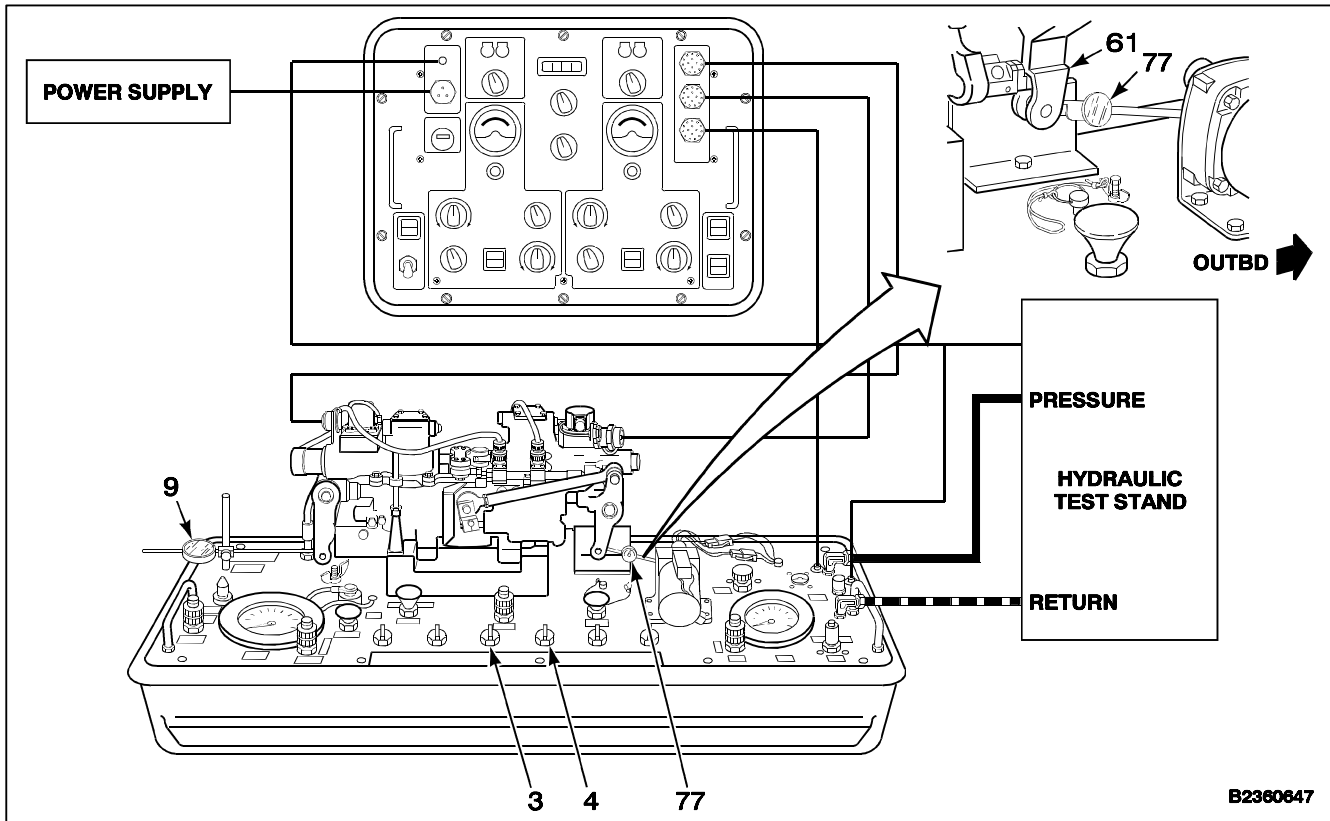

137. Set electrical and hydraulic unit controls as follows:
 - a. HIGH PRESS REGULATOR valve (52) to DECREASE.
 - b. SOLENOID SHUTOFF switch (44) to CLOSED.
 - c. SOLENOID valve (53) to CLOSED.
 - d. Press and hold HIGH PRESS RELIEF VALVE (67) until HIGH PRESS gauge (13) indicates **0 psi**.
 - e. HIGH PRESS SHUTOFF VALVE (51) to CLOSE.
 - f. ILCA PRESS SYS 1 valve (1), ILCA PRESS SYS 2 valve (2). RETURN SYS 1 valve (5), and RETURN SYS 2 valve (6) to OFF.

138. Remove dial indicator (77).
139. If not needed for further testing, remove dial indicator (9).

NOTE

Dial indicator is used in Tests 7, 8, 9, 10, and 17.

140. If no further testing is required, perform a normal shutdown. (Refer to TM 55-4920-428-13.)

END STATIC DEADBAND TEST

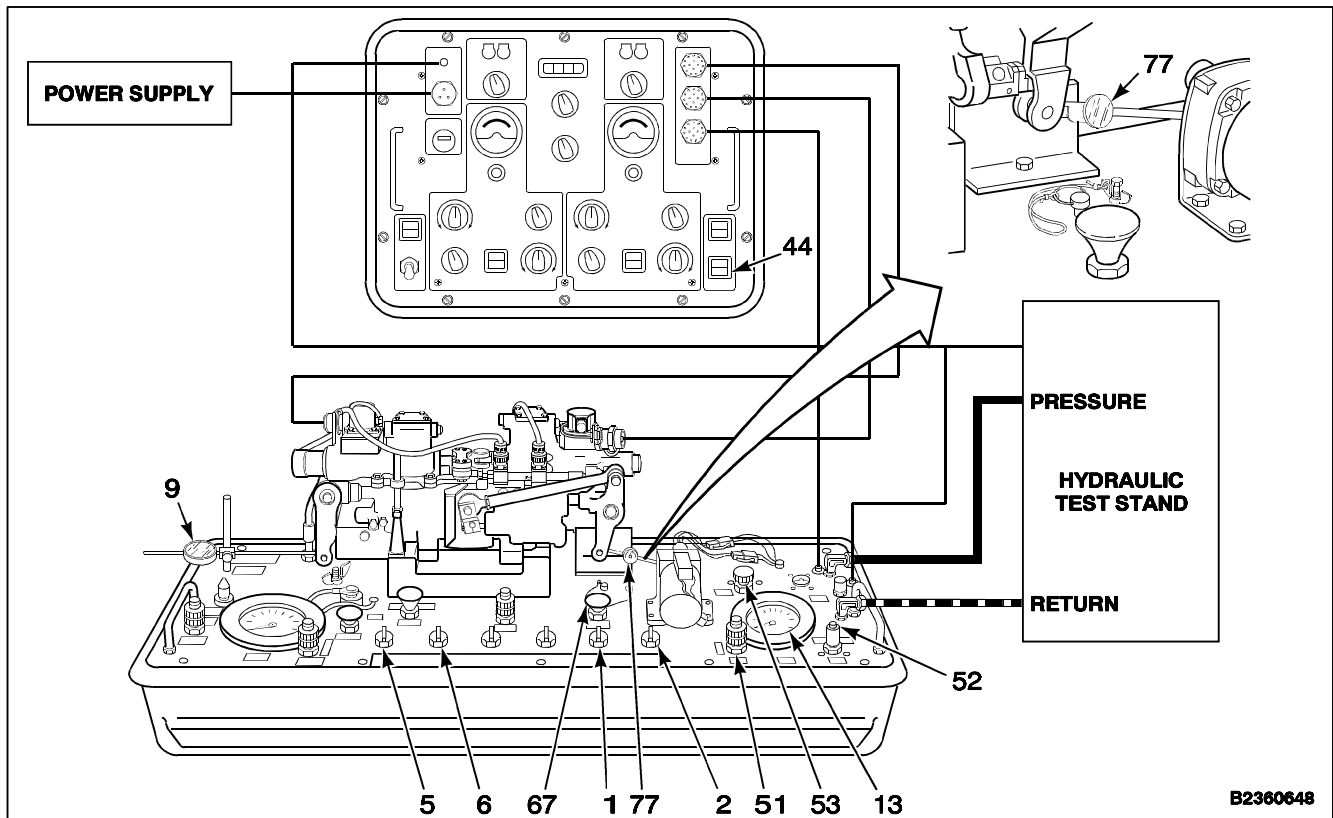

TEST 10

EXTENSIBLE LINK STABILITY TEST (SPARE)

141. Perform steps 1 thru 40. Check initial control and valve settings in steps 22 and 23.

NOTE

Tests 2, 3, 4, and 5 **MUST** be performed before this test.

142. Set electrical and hydraulic unit controls as follows:

- a. Check RETURN SHUTOFF valve (47) is OPEN.
- b. RETURN SYS 1 valve (5) and RETURN SYS 2 valve (6) to RETURN.
- c. SOLENOID valve (53) to OPENED.
- d. SOLENOID SHUTOFF switch (44) to OPEN.
- e. Slowly turn HIGH PRESS REGULATOR valve (52) towards INCREASE until HIGH PRESS gauge (13) indicates **1500 psi**.

- f. ILCA PRESS SYS 1 valve (1) and ILCA PRESS SYS 2 valve (2) to PRESS.
- g. Slowly turn HIGH PRESS SHUTOFF valve (51) to OPEN.
- h. Install dial indicator (9). (Refer to steps 93 thru 95.)

- 142.1. Install PIN 2 (69) in input arm (61).
- 143. Set SAS PRESS SYS 1 valve (3) and SAS PRESS SYS 2 valve (4) to PRESS.
- 144. Turn SAS 1 FUNCTION SELECT switch (30) through HARD OVER RETRACT BALANCE, and HARD OVER EXTEND **three times**. Check dial indicator (9) for oscillations at BALANCE. There shall be no oscillation. An overshoot of **0.002 to 0.005 inch** is allowed, but link shall stop within **1 second**.
- 144.1. Set SAS 1 FUNCTION SELECT switch to BALANCE.

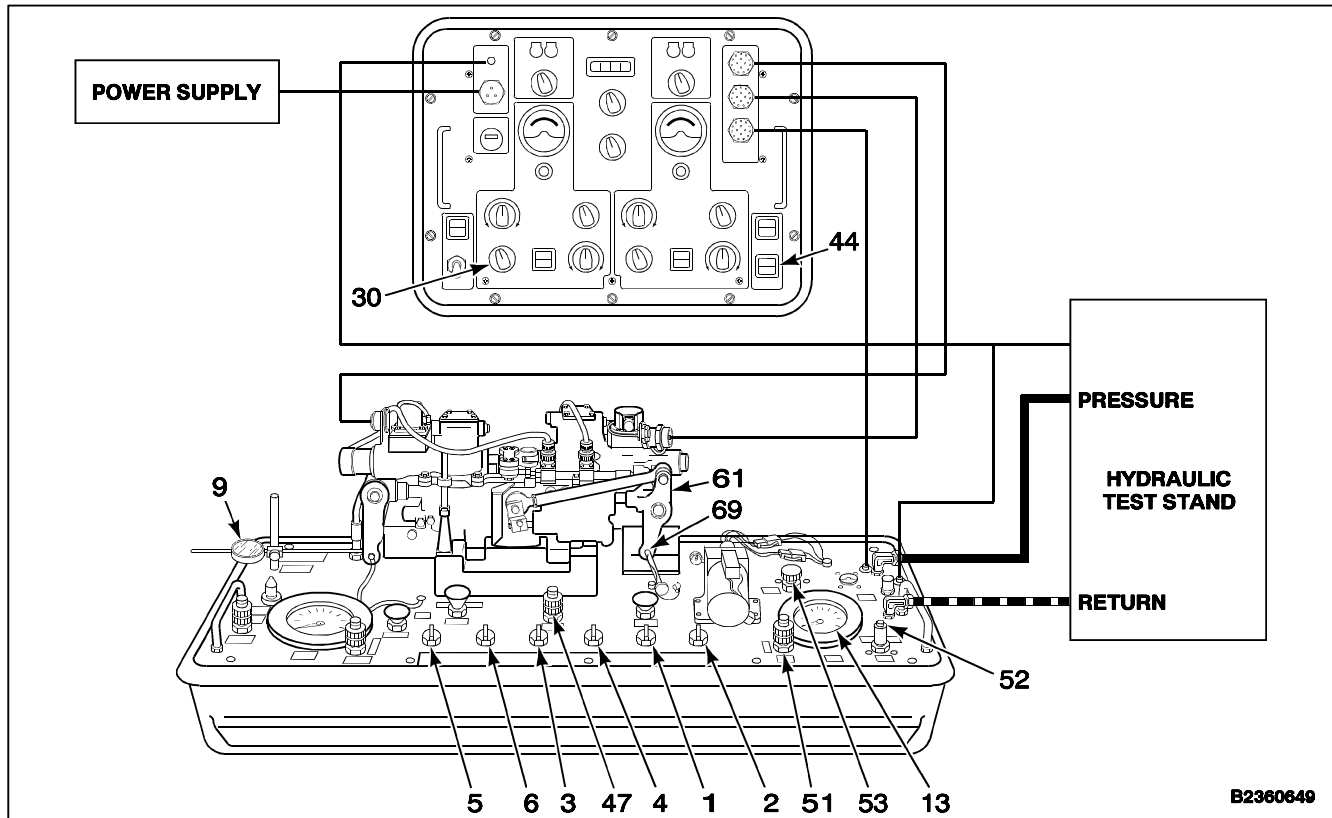

- 145. Set SAS 2 FUNCTION SELECT switch (31) to HARD OVER RETRACT, BALANCE and HARD OVER EXTEND **three times**. Check dial indicator (9) for oscillations at BALANCE. There shall be no oscillations. An overshoot of **0.002 to 0.005 inch** is allowed, but link shall stop within **1 second**.

NOTE

If overshoot exceeds **0.005 inch** in step 144 or 145, replace extensible link. If link oscillates, replace servomotor or extensible link.

- 146. Set electrical unit controls as follows:

- a. SAS 1 FUNCTION SELECT switch (30) to CLSD LOOP.
- b. SAS 2 FUNCTION SELECT switch (31) to CLSD LOOP.

- 147. Set electrical and hydraulic unit controls as follows:

- a. HIGH PRESS REGULATOR valve (52) to DECREASE.
- b. SOLENOID SHUTOFF switch (44) to CLOSE.
- c. SOLENOID valve (53) to CLOSE.

- d. Press and hold HIGH PRESS RELIEF VALVE (67) and LOW PRESS RELIEF VALVE (68) until HIGH PRESS gauge (13) indicates **0 psi**.
- e. HIGH PRESS SHUTOFF valve (51) to CLOSE.
- f. ILCA PRESS SYS 1 valve (1), ILCA PRESS SYS 2 valve (2), SAS PRESS SYS 1 valve (3), and SAS PRESS SYS 2 valve (4) to VENT then OFF.
- g. RETURN SYS 1 valve (5) and RETURN SYS 2 valve (6) to OFF.

- 148. If not needed for further testing, remove dial indicator (9).

NOTE

Dial indicator used in Tests 7, 8, 9, 10, and 17.

- 149. Remove PIN 3 (73) and bearing (75) from output arm (74). Remove PIN 2 (69) from input arm (61) and stow.

- 150. If no further testing is required, perform a normal shutdown (TM 55-4920-428-13).

END EXTENSIBLE LINK STABILITY TEST

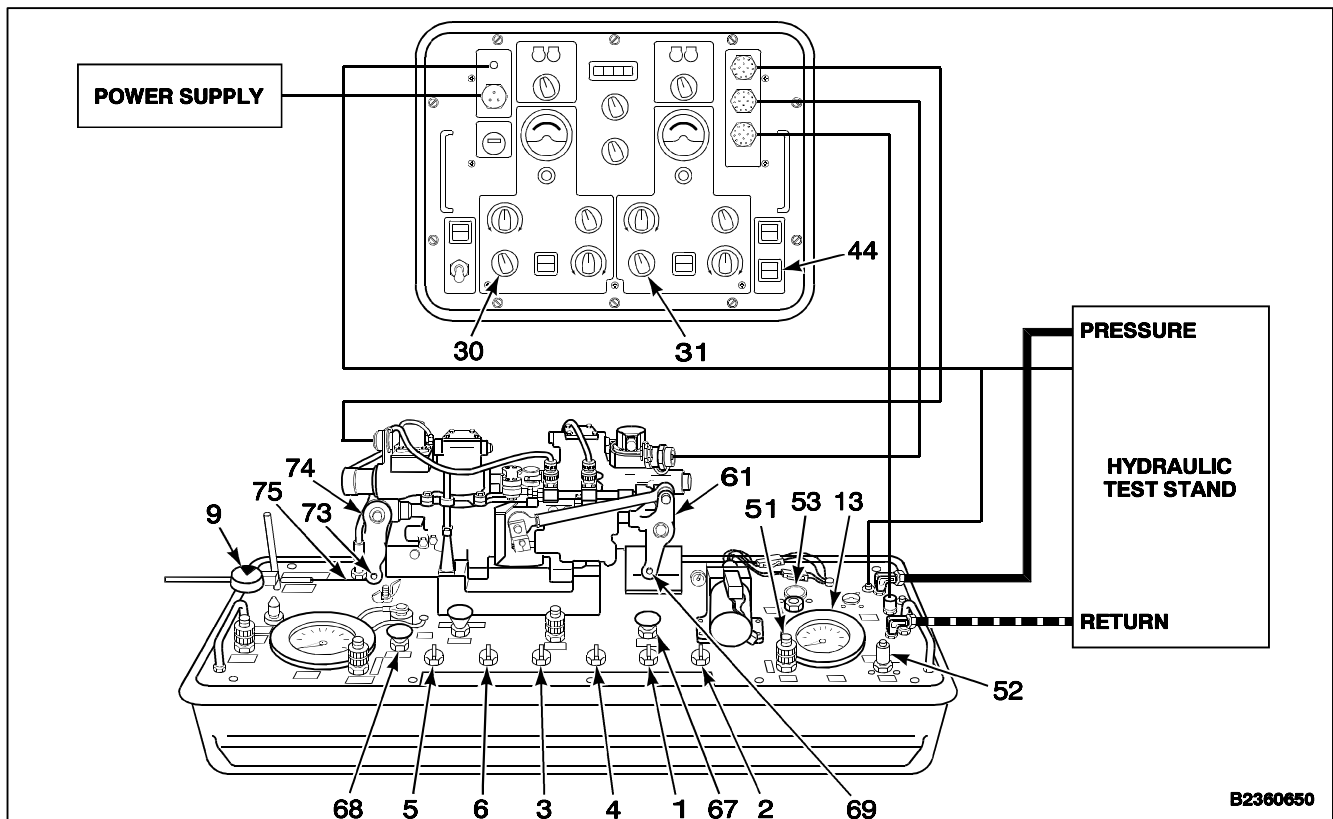

TEST 11

EXTENSIBLE LINK CENTERING SPRINGS TEST (SPARE)

151. Perform steps 1 thru 40. Check initial control and valves in steps 22 and 23.

NOTE

Tests 2, 3, 4, and 5 **MUST** be performed before this test.

152. Set electrical unit controls as follows:

- a. SAS 1 FUNCTION SELECT switch (30) to CLSD LOOP.
- b. SAS 1 VALVE CONTROL switch (34) to NULL.
- c. SAS 1 LINK TEST switch (38) to CROSS FDBK.
- d. SAS 2 FUNCTION SELECT switch (31) to CLSD LOOP.
- e. SAS 2 VALVE CONTROL switch (35) to NULL.
- f. SAS 2 LINK TEST switch (39) to CROSS FDBK.

g. SYSTEM SELECT switch (43) to SAS 1.

153. Set up electrical and hydraulic unit controls as follows:

- a. Check RETURN SHUTOFF valve (47) is OPEN.
- b. RETURN SYS 1 valve (5) and RETURN SYS 2 valve (6) to RETURN.
- c. SOLENOID valve (53) to OPENED.
- d. SOLENOID SHUTOFF switch (44) to OPEN.
- e. Slowly turn HIGH PRESS REGULATOR valve (52) to INCREASE until HIGH PRESS gauge (13) indicates **1500 psi**.
- f. ILCA PRESS SYS 1 valve (1) and ILCA PRESS SYS 2 valve (2) to PRESS.
- g. Slowly turn HIGH PRESS SHUTOFF valve (51) to OPEN.

154. SAS PRESS SYS 1 valve (3) to PRESS.

155. Insert PIN 2 (69) in input arm (61) through fixture (70).

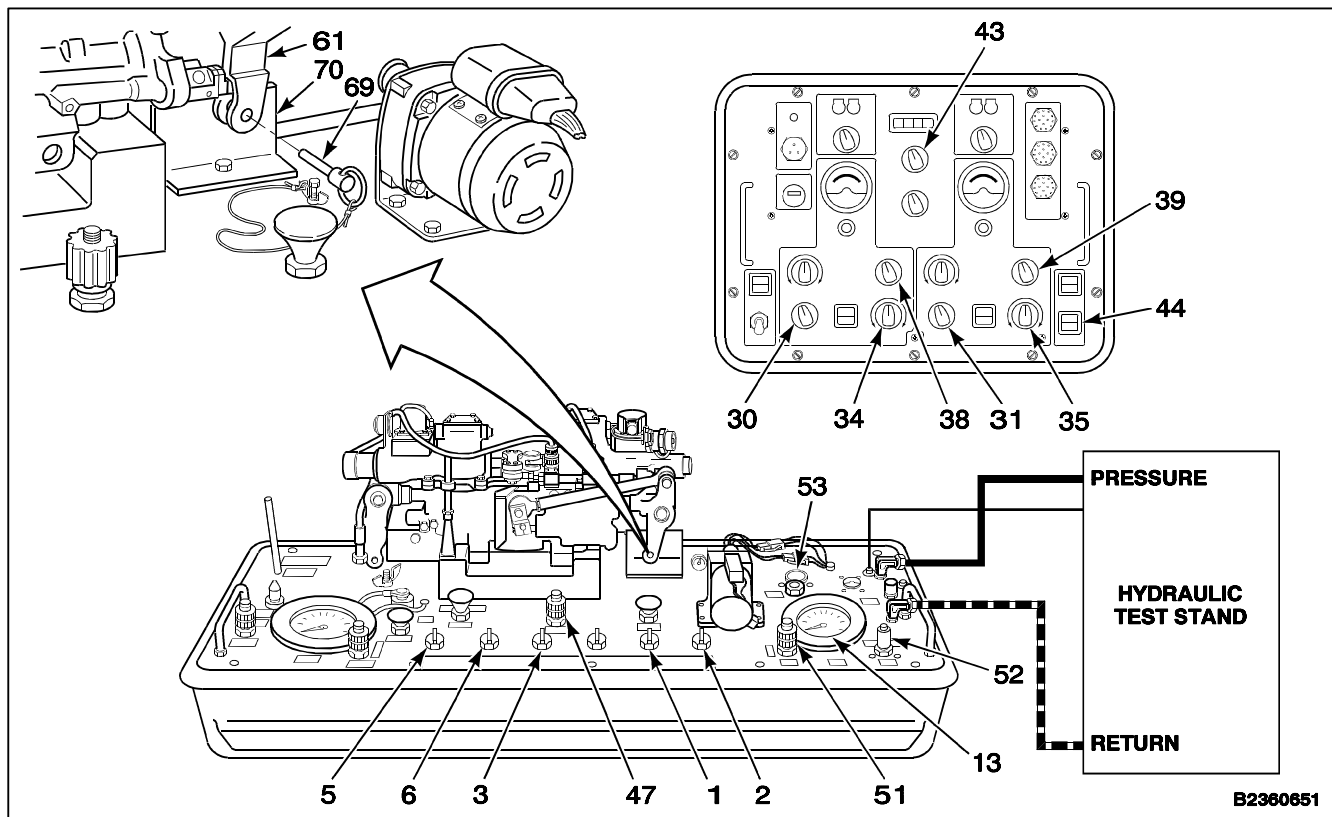

7-98 TEST PITCH, ROLL, YAW, OR THRUST INTEGRATED LOWER CONTROL ACTUATOR (ILCA) (AVIM) (Continued)

- 156. Set SAS 1 VALVE CONTROL (34) to EXTEND.
- 157. Set SAS PRESS SYS 1 valve (3) to OFF. Read and record cross feedback reading on DVM (58). Compare reading with null reading from step 55. The difference shall be **0.065 or less**.
- 158. Set SAS PRESS SYS 1 valve (3) to PRESS.
- 159. Set SAS PRESS SYS 1 valve (3) to OFF. Read and record cross feedback reading on DVM (58). Compare reading with null reading from step 55. The difference shall be **0.065 or less**.
- 160. Set SAS PRESS SYS 1 valve (3) to PRESS.
- 161. Set SAS PRESS SYS 1 valve (3) to OFF. Read and record cross feedback reading on DVM (58). Compare reading with null reading from step 55. The difference shall be **0.065 or less**.
- 162. Set SAS PRESS SYS 1 valve (3) to PRESS.
- 163. Set SAS PRESS SYS 1 valve (3) to OFF. Read and record cross feedback reading on DVM (58). Compare reading with null reading from step 55. The difference shall be **0.065 or less**.
- 164. Set SAS 1 VALVE CONTROL (34) to RETRACT. Set SAS PRESS SYS 1 valve (3) to PRESS.

NOTE

If voltage reading is not within limits, replace extensible link.

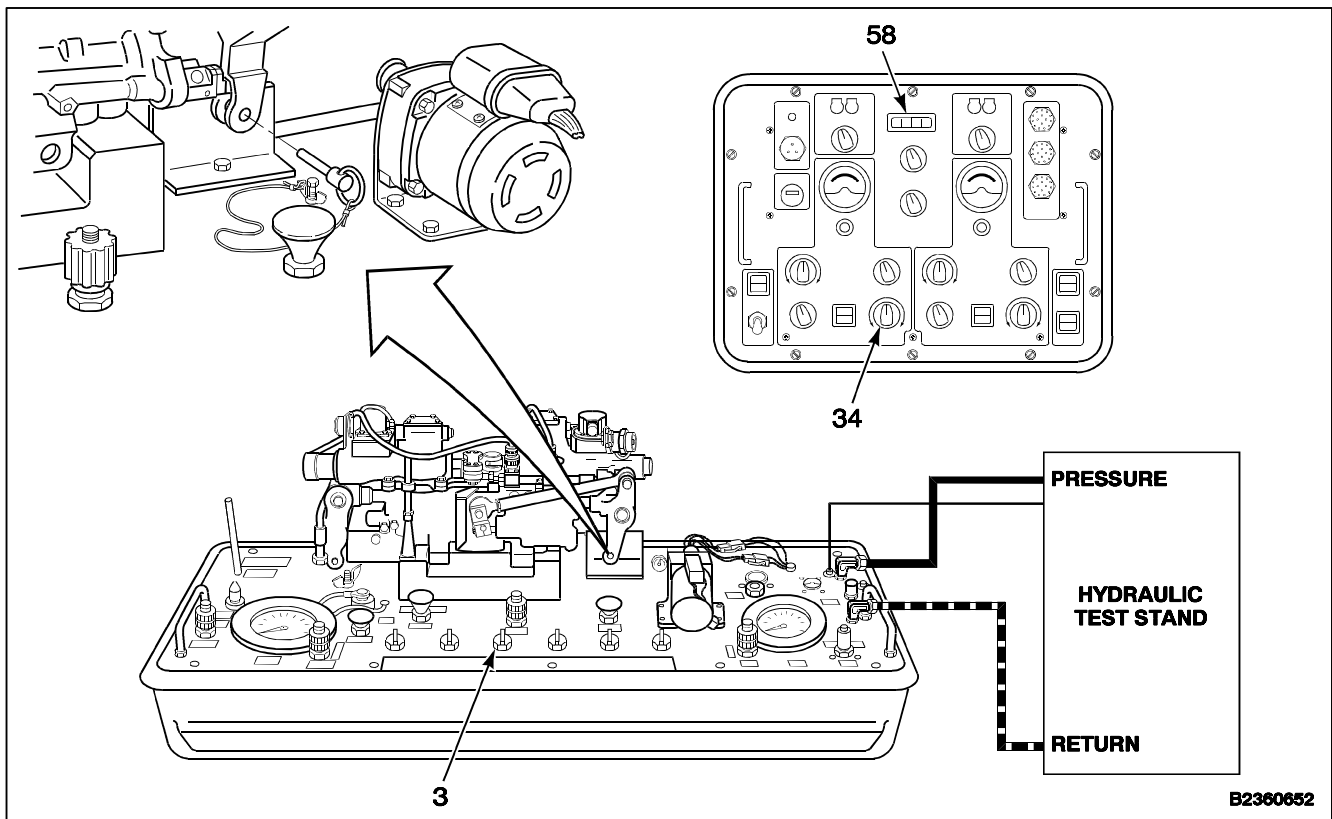

B2360652

- 165. Set SAS PRESS SYS 1 valve (3) to OFF. Read and record cross feedback reading on DVM (58). Compare reading with null reading from step 55. The difference shall be **0.065 or less**.
- 166. Set SAS PRESS SYS 1 valve (3) to PRESS.
- 167. Set SAS PRESS SYS 1 valve (3) to OFF. Read and record cross feedback reading on DVM (58). Compare reading with null reading from step 55. The difference shall be **0.065 or less**.
- 168. Set SAS PRESS SYS 1 valve (3) to PRESS.
- 169. Set SAS PRESS SYS 1 valve (3) to OFF. Read and record cross feedback reading on DVM (58). Compare reading with null reading from step 55. The difference shall be **0.065 or less**.

- 169.1. Set SAS PRESS SYS 1 valve (3) to PRESS.
- 169.2. Set SAS PRESS SYS 1 valve (3) to OFF. Read and record cross feedback reading on DVM (58). Compare reading with null reading from step 55. The difference shall be **0.065 or less**.

NOTE

If voltage reading is not within limits, replace extensible link.

- 170. Set SAS 1 VALVE CONTROL (34) to NULL.
- 171. Set SAS PRESS SYS 1 valve (3) to VENT then OFF.

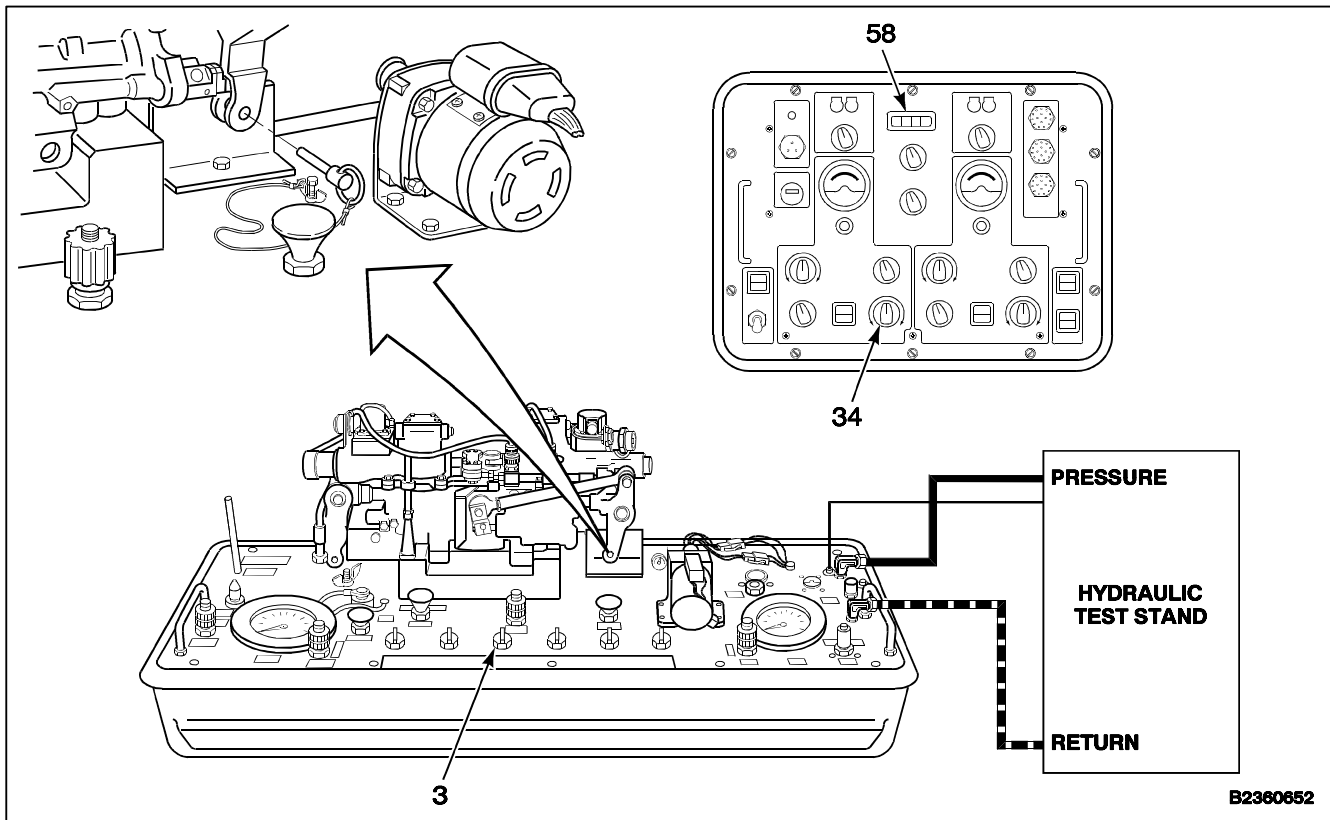

B2360652

7-98 TEST PITCH, ROLL, YAW, OR THRUST INTEGRATED LOWER CONTROL ACTUATOR (ILCA) (AVIM) (Continued)

- 172. Set SYSTEM SELECT switch (43) to SAS 2.
- 173. Set SAS PRESS SYS 2 valve (4) to PRESS.
- 174. Set SAS 2 VALVE CONTROL (35) to EXTEND.
- 175. Set SAS PRESS SYS 2 valve (4) to OFF. Read and record cross feedback reading on DVM (58). Compare reading with null reading from step 55. The difference shall be **0.065 or less**.
- 176. Set SAS PRESS SYS 2 valve (4) to PRESS.
- 177. Set SAS PRESS SYS 2 valve (4) to OFF. Read and record cross feedback reading on DVM (58). Compare reading with null reading from step 55. The difference shall be **0.065 or less**.
- 178. Set SAS PRESS SYS 2 valve (4) to PRESS.
- 179. Set SAS PRESS SYS 2 valve (4) to OFF. Read and record cross feedback reading on DVM (58). Compare reading with null reading from step 55. The difference shall be **0.065 or less**.
- 180. Set SAS PRESS SYS 2 valve (4) to PRESS.
- 181. Set SAS PRESS SYS 2 valve (4) to OFF. Read and record cross feedback reading on DVM (58). Compare reading with null reading from step 55. The difference shall be **0.065 or less**.
- NOTE
If voltage reading is not within limits, replace extensible link.
- 182. Set SAS 2 VALVE CONTROL (35) to RETRACT.
- 183. Set SAS PRESS SYS 2 valve (4) to PRESS.

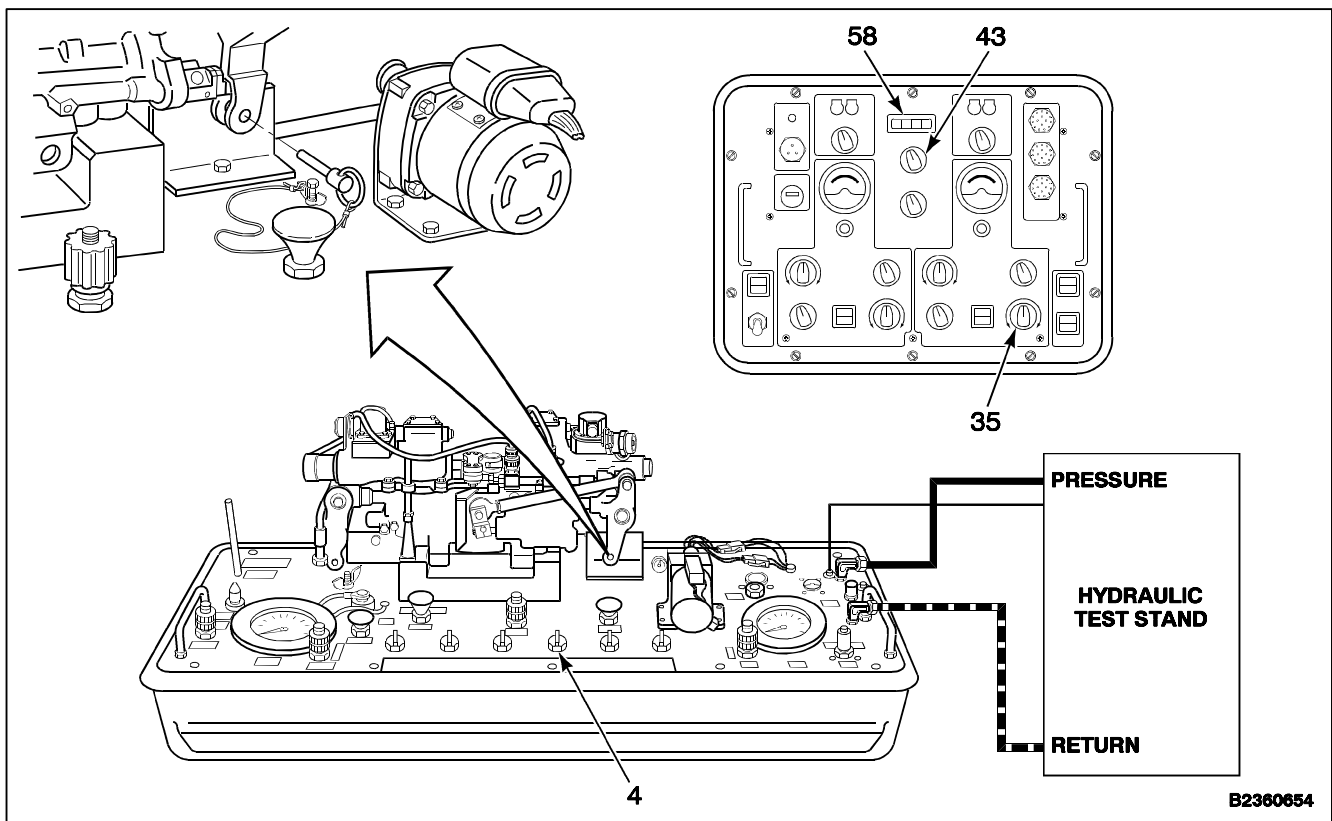

- 184. Set SAS PRESS SYS 2 valve (4) to OFF. Read and record cross feedback reading on DVM (58). Compare reading with null reading from step 55. The difference shall be **0.065 or less**.
- 185. Set SAS SYS 2 valve (4) to PRESS.
- 186. Set SAS PRESS SYS 2 valve (4) to OFF. Read and record cross feedback reading on DVM (58). Compare reading with null reading from step 55. The difference shall be **0.065 or less**.
- 187. Set SAS PRESS SYS 2 valve (4) to PRESS.
- 188. Set SAS PRESS SYS 2 valve (4) to OFF. Read and record cross feedback reading on DVM (58). Compare reading with null reading from step 55. The difference shall be **0.065 or less**.
- 189. Set SAS PRESS SYS 2 valve (4) to PRESS.
- 190. Set SAS PRESS SYS 2 valve (4) to OFF. Read and record cross feedback reading on DVM (58). Compare reading with null reading from step 55. The difference shall be **0.065 or less**.
- 191. Set SAS 2 VALVE CONTROL (35) to NULL.
- 192. Set SAS PRESS SYS 2 valve (4) to VENT and then to OFF.
- 193. Deleted.
- 194. Set electrical and hydraulic unit controls as follows:
 - a. HIGH PRESSURE REGULATOR valve (52) to DECREASE.
 - b. SOLENOID SHUTOFF switch (44) to CLOSED.
 - c. SOLENOID valve (53) to CLOSED.
 - d. ILCA PRESS SYS 1 valve (1) and ILCA PRESS SYS 2 valve (2) to VENT.
 - e. HIGH PRESS SHUTOFF valve (51) to CLOSE.
 - f. Push and hold HIGH PRESS RELIEF VALVE (67) and LOW PRESS RELIEF VALVE (68) for **15 seconds**.
 - g. ILCA PRESS SYS 1 valve (1), ILCA PRESS SYS 2 valve (2), RETURN SYS 1 valve (5), and RETURN SYS 2 valve (6) to OFF.
- 195. Remove and stow PIN 2 (69) from fixture (70) and input arm (61).
- 196. If no further testing is required, perform normal shutdown (TM 55-4920-428-13).

END CENTERING SPRINGS TEST

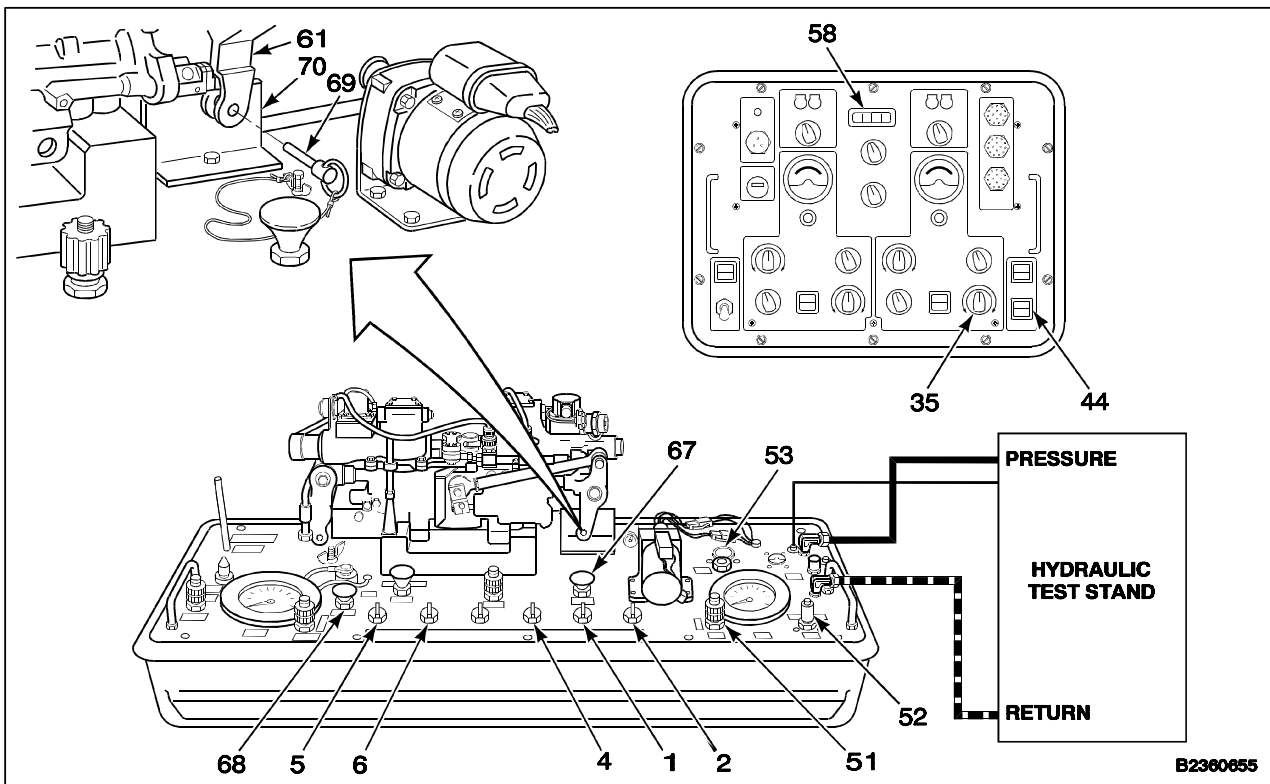

B2380855

TEST 12

PROOF PRESSURE TEST (ALL)

197. Perform steps 1 thru 40. Check initial control and valve settings steps 22 and 23.

NOTE

Tests 2, 3, 4, and 5 **MUST** be performed before this test.

198. Set electrical and hydraulic unit controls as follows:

- a. Check RETURN SHUTOFF valve (47) is OPEN.
- b. RETURN SYS 1 valve (5) and RETURN SYS 2 valve (6) to RETURN.
- c. SOLENOID valve (53) to OPEN.

- d. SOLENOID SHUTOFF switch (44) to OPEN.
- e. Slowly turn HIGH PRESS REGULATOR valve (52) toward INCREASE until HIGH PRESS gauge (13) indicates **1500 psi**.
- f. ILCA PRESS SYS 1 valve (1), ILCA PRESS SYS 2 valve (2), SAS PRESS SYS 1 valve (3), and SAS PRESS SYS 2 valve (4) to PRESS.
- g. Slowly turn HIGH PRESS SHUTOFF valve (51) to OPEN.

- 199. Install PIN 2 (69) through input arm (61) and fixture (70).
- 200. Turn HIGH PRESS SHUTOFF valve (51) to CLOSE.
- 201. Turn HIGH PRESS REGULATOR valve (52) to full DECREASE.

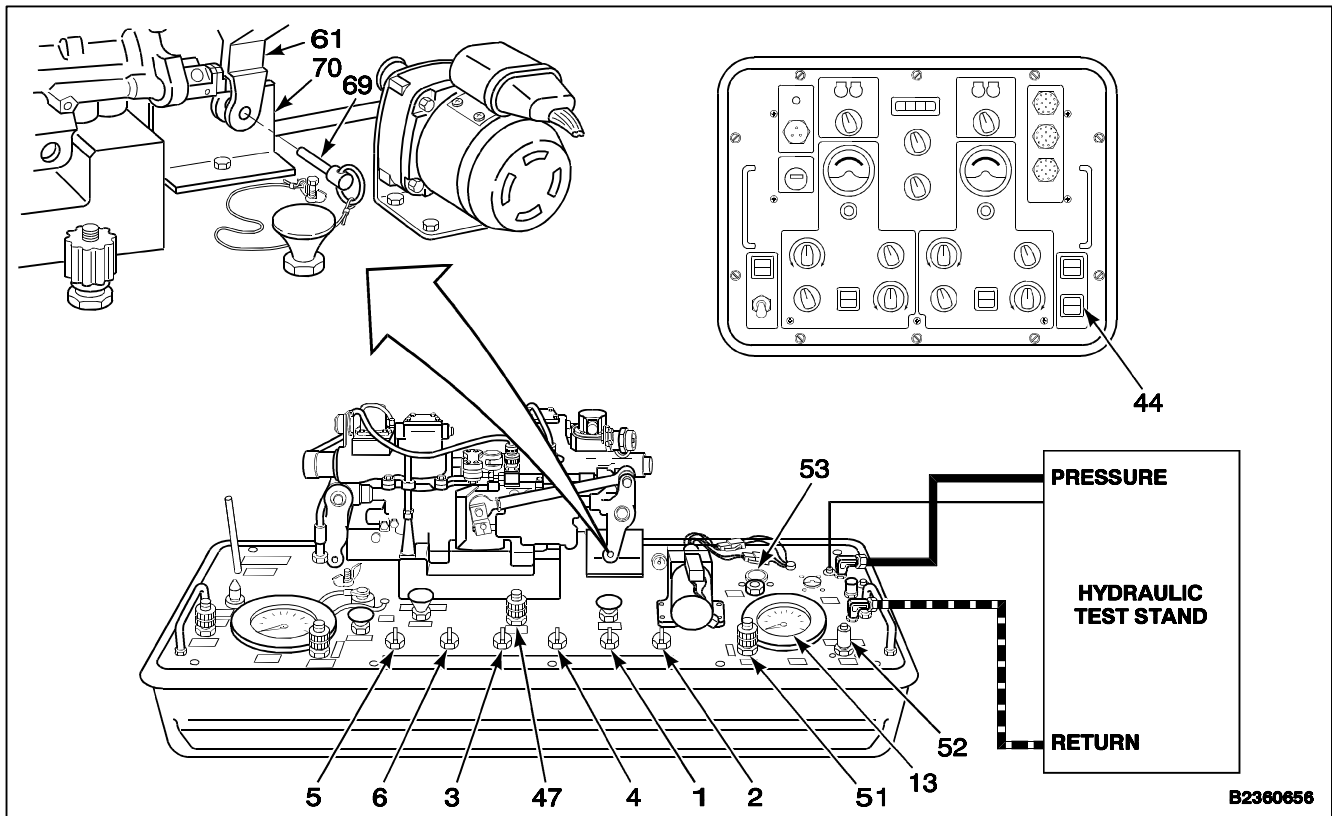

202. Increase test stand pressure to **2600 psi**.



High pressure hydraulic leaks can cause serious bodily injury.

203. Slowly turn HIGH PRESS REGULATOR valve (52) toward INCREASE until HIGH PRESS gauge (13) reads **2250 psi**. Hold pressure for **five minutes**.

204. Slowly turn HIGH PRESS SHUTOFF valve (51) to OPEN.

205. Check for external leaks or damage. There shall be no external leaks or signs of damage.

NOTE

If external leaks appear, stop test and repair as required. If unable to repair, replace next higher assembly.

206. Set electrical and hydraulic unit controls as follows:

- a. HIGH PRESS REGULATOR valve (52) to DECREASE.
- b. Turn HIGH PRESS SHUTOFF valve (51) to CLOSE.
- c. SOLENOID SHUTOFF switch (44) to CLOSED.
- d. SOLENOID VALVE (53) to CLOSED.
- e. ILCA PRESS SYS 1 valve (1), ILCA PRESS SYS 2 valve (2), SAS PRESS SYS 1 valve (3), and SAS PRESS SYS 2 valve (4) to VENT.

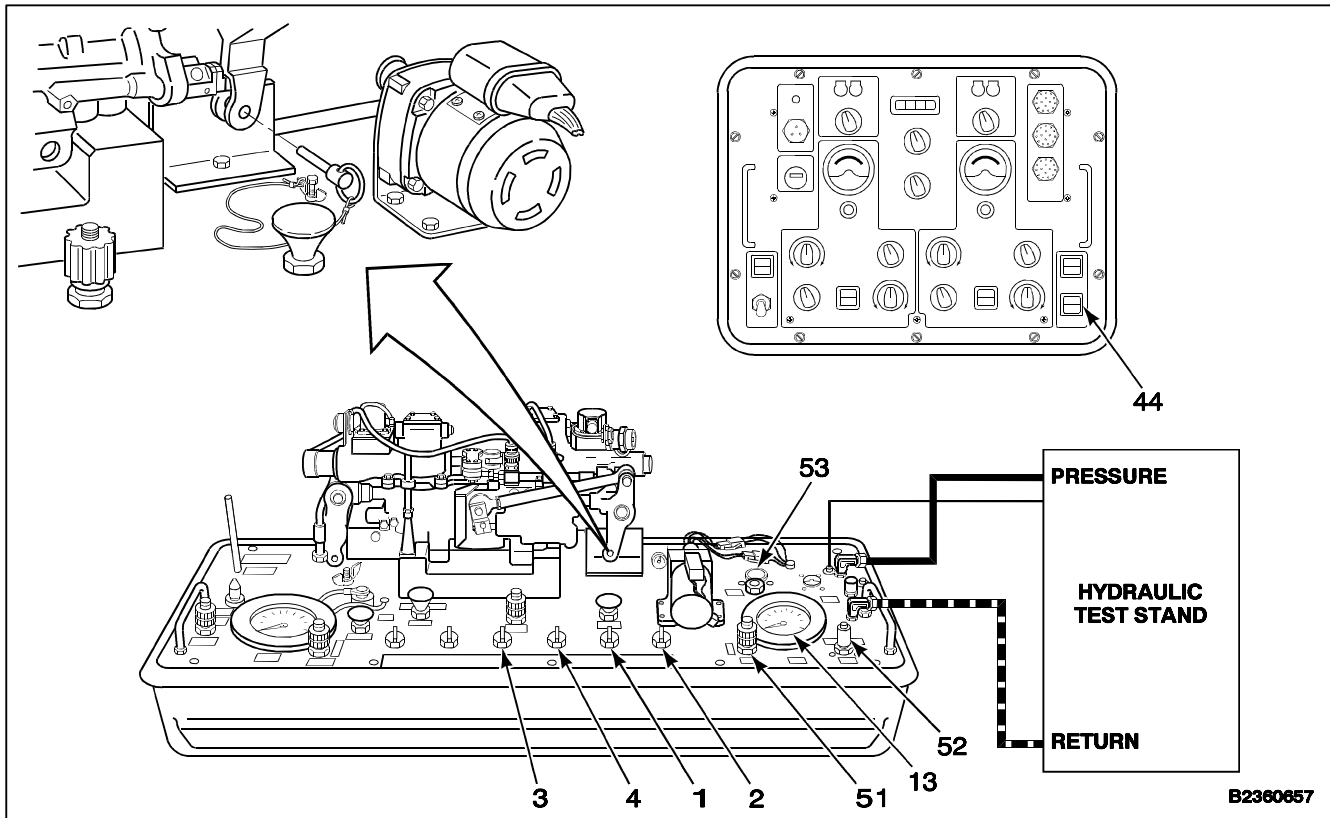

B2360657

7-98 TEST PITCH, ROLL, YAW, OR THRUST INTEGRATED LOWER CONTROL ACTUATOR (ILCA) (AVIM) (Continued)

7-98

207. Press and hold HIGH PRESS RELIEF valve (67) and LOW PRESS RELIEF valve (68) for **15 seconds**.
208. Set ILCA PRESS SYS 1 valve (1), ILCA PRESS SYS 2 valve (2), SAS PRESS SYS 1 valve (3), and SAS PRESS SYS 2 valve (4) to OFF.
209. Set RETURN SYS 1 valve (5) and RETURN SYS 2 valve (6) to OFF.
210. Remove and stow PIN 2 (69).
211. Reduce hydraulic test stand pressure to **1500 psi**.
212. If no further testing is required, perform normal shutdown. (Refer to TM 55-4920-428-13.)

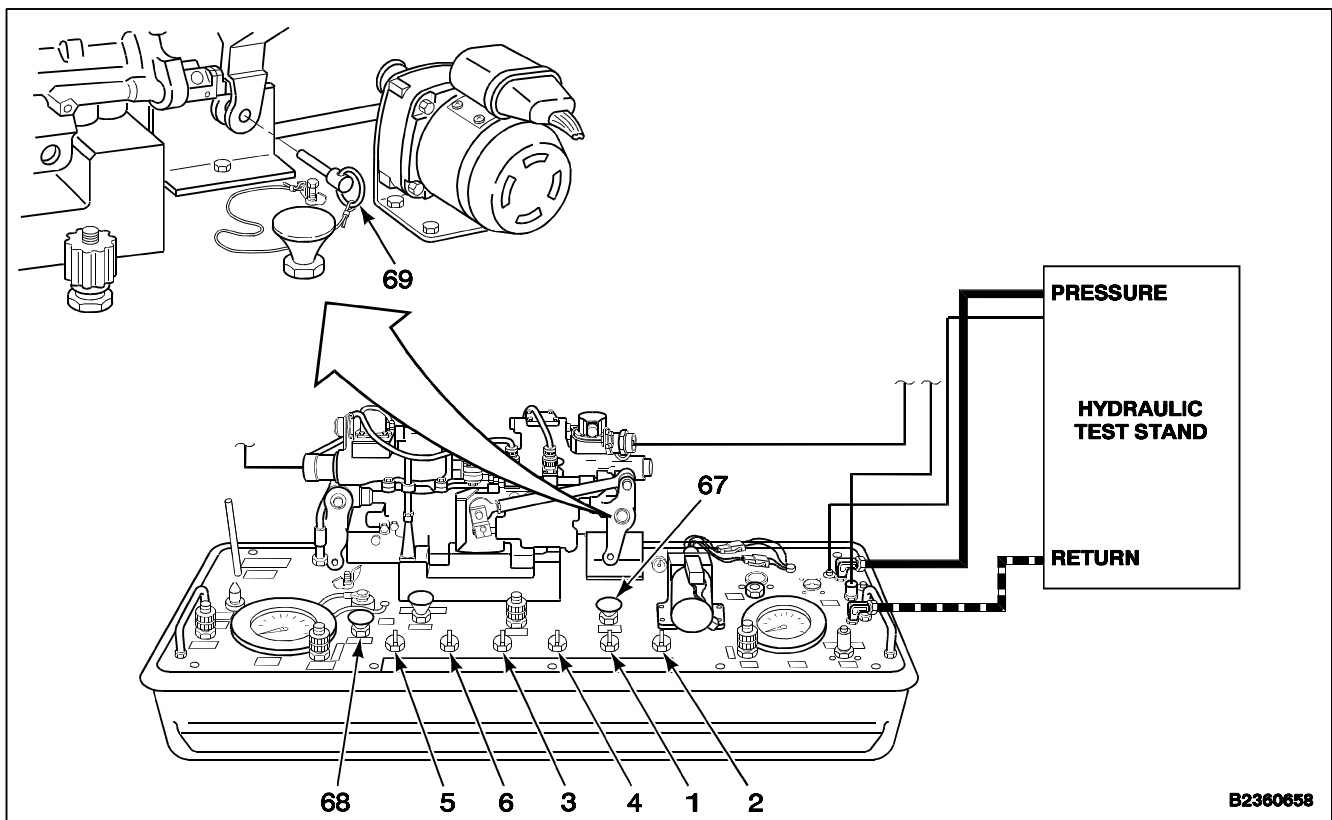
END PROOF PRESSURE TEST

TEST 13

RETURN PRESSURE TEST (ALL)

213. Perform steps 1 thru 40. Check initial control and valve settings in steps 22 and 23.

NOTE

Tests 2, 3, 4, and 5 **MUST** be performed before this test.

214. Set electrical and hydraulic unit controls as follows:

- a. Check RETURN SHUTOFF valve (47) is OPEN.
- b. RETURN SYS 1 valve (5) and RETURN SYS 2 valve (6) to RETURN.
- c. SOLENOID valve (53) to OPENED.
- d. SOLENOID SHUTOFF switch (44) to OPEN.
- e. Slowly turn HIGH PRESS REGULATOR valve (52) toward INCREASE until HIGH PRESS gauge (13) indicates **1000 psi**.
- f. ILCA PRESS SYS 1 valve (1), ILCA PRESS SYS 2 valve (2), SAS PRESS SYS 1 valve (3), and SAS PRESS SYS 2 valve (4) to PRESS.

g. Slowly turn HIGH PRESS SHUTOFF valve (51) to OPEN.

215. Starting with arm (61) fully outward, perform the following:

- a. Manually move actuator through **one cycle**.
- b. Slowly turn RETURN SHUTOFF valve (47) towards CLOSE while moving input arm (61) until arm stops moving.
- c. Turn SAS 1 VALVE CONTROL valve (34) and SAS 2 VALVE CONTROL valve (35) to EXTEND then RETRACT. Check that HIGH PRESS gauge (13) indicates **1000 psi**.
- d. Let actuator stay in this condition for **5 minutes**.

NOTE

Movement of extensible link feedback linkage after arm stops is normal.

216. Check for external leakage or signs of damage. There shall be no leakage or signs of damage.

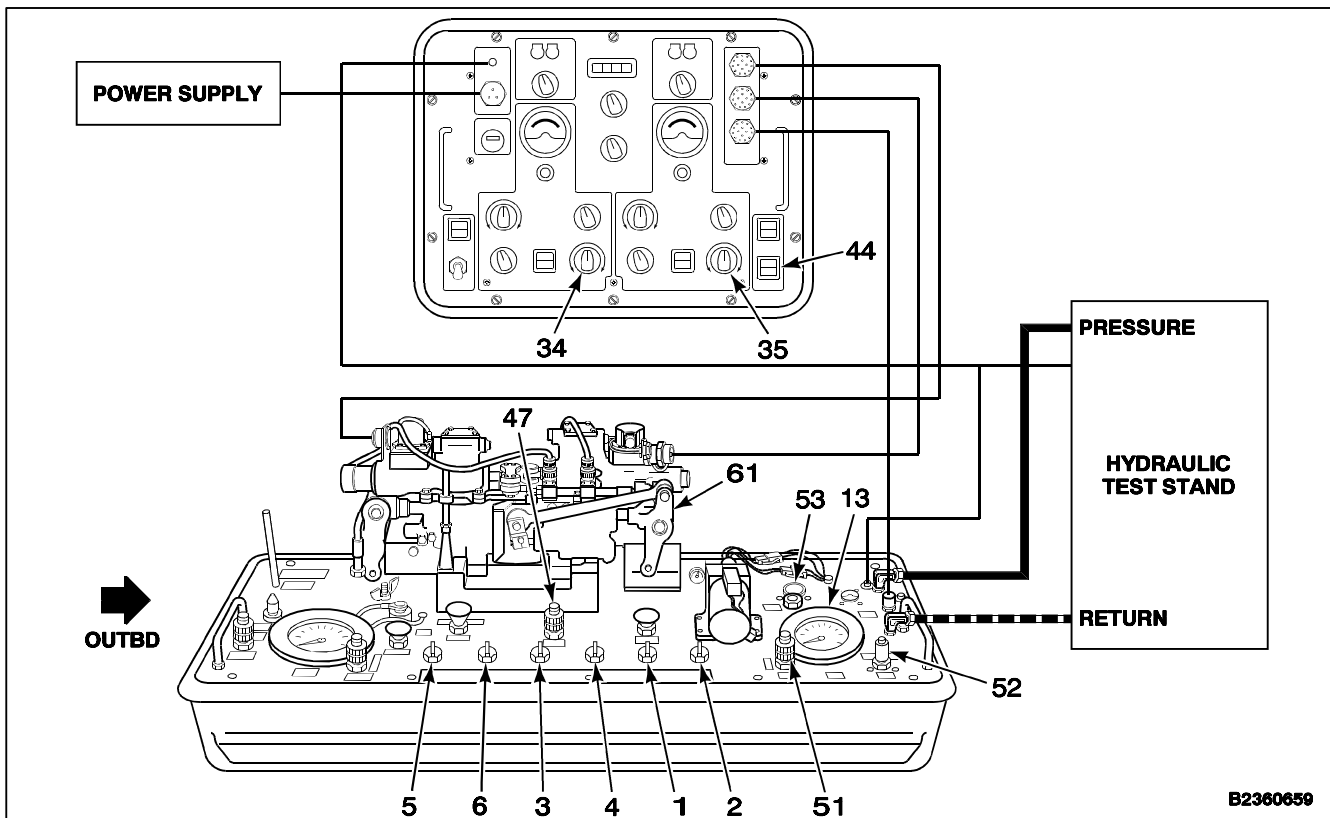

217. Set electrical and hydraulic unit controls as follows:
- a. RETURN SHUTOFF valve (47) to OPEN.
 - b. HIGH PRESS REGULATOR valve (52) to DECREASE.
 - c. SOLENOID SHUTOFF switch (44) to CLOSED.
 - d. SOLENOID valve (53) to CLOSED.
 - e. Press and hold HIGH PRESS RELIEF valve (67) and LOW PRESS RELIEF valve (68) for **15 seconds**. Release valves.
 - f. Set HIGH PRESS SHUTOFF valve (51) to CLOSE.
 - g. ILCA PRESS SYS 1 valve (1), ILCA PRESS SYS 2 valve (2), SAS PRESS SYS 1 valve (3), and SAS PRESS SYS 2 valve (4) to VENT then OFF.
 - h. RETURN SYS 1 valve (5), and RETURN SYS 2 valve (6) to OFF.
218. If jam indicator (78) extends, reset it.
219. If no further testing is required, perform normal shutdown (TM 55-4920-428-13).

END RETURN PRESSURE TEST

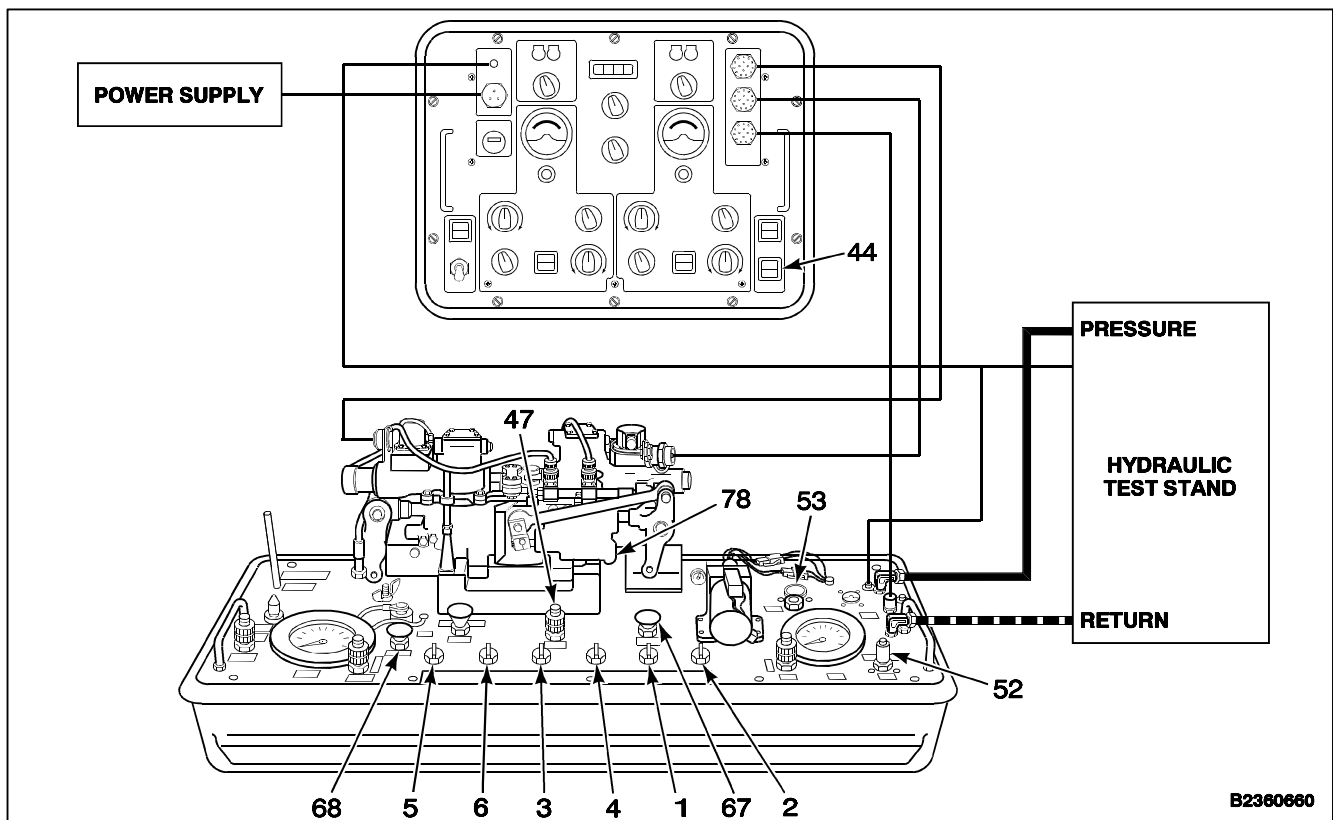

B2360660

TEST 14

VALVE JAM INDICATOR TEST (ALL)

220. Perform steps 1 thru 40. Check initial control and valve setting in steps 22 and 23.

221. Set electrical and hydraulic unit controls as follows:

- a. Check RETURN SHUTOFF valve (47) is OPEN.
- b. RETURN SYS 1 valve (5) and RETURN SYS 2 valve (6) to RETURN.
- c. SOLENOID valve (53) to OPENED.
- d. SOLENOID SHUTOFF switch (44) at OPEN.
- e. Slowly turn HIGH PRESS REGULATOR valve (52) toward INCREASE until HIGH PRESS gauge (13) indicates **1500 psi**.
- f. SAS PRESS SYS 1 valve (3) and SAS PRESS SYS 2 valve (4) to PRESS.

222. Set ILCA PRESS SYS 1 valve (1) to PRESS.

223. Slowly turn HIGH PRESS SHUTOFF valve (51) to OPEN.

224. Turn HIGH PRESS SHUTOFF valve (51) to CLOSE.

225. Set ILCA PRESS SYS 1 valve (1) to VENT.

226. Repeat steps 220 thru 224 **three times**. Jam indicator button (78) shall remain flush with valve (79) body.

227. Set ILCA PRESS SYS 1 valve (1) to PRESS.

228. Slowly turn HIGH PRESS SHUTOFF valve (51) to OPEN.

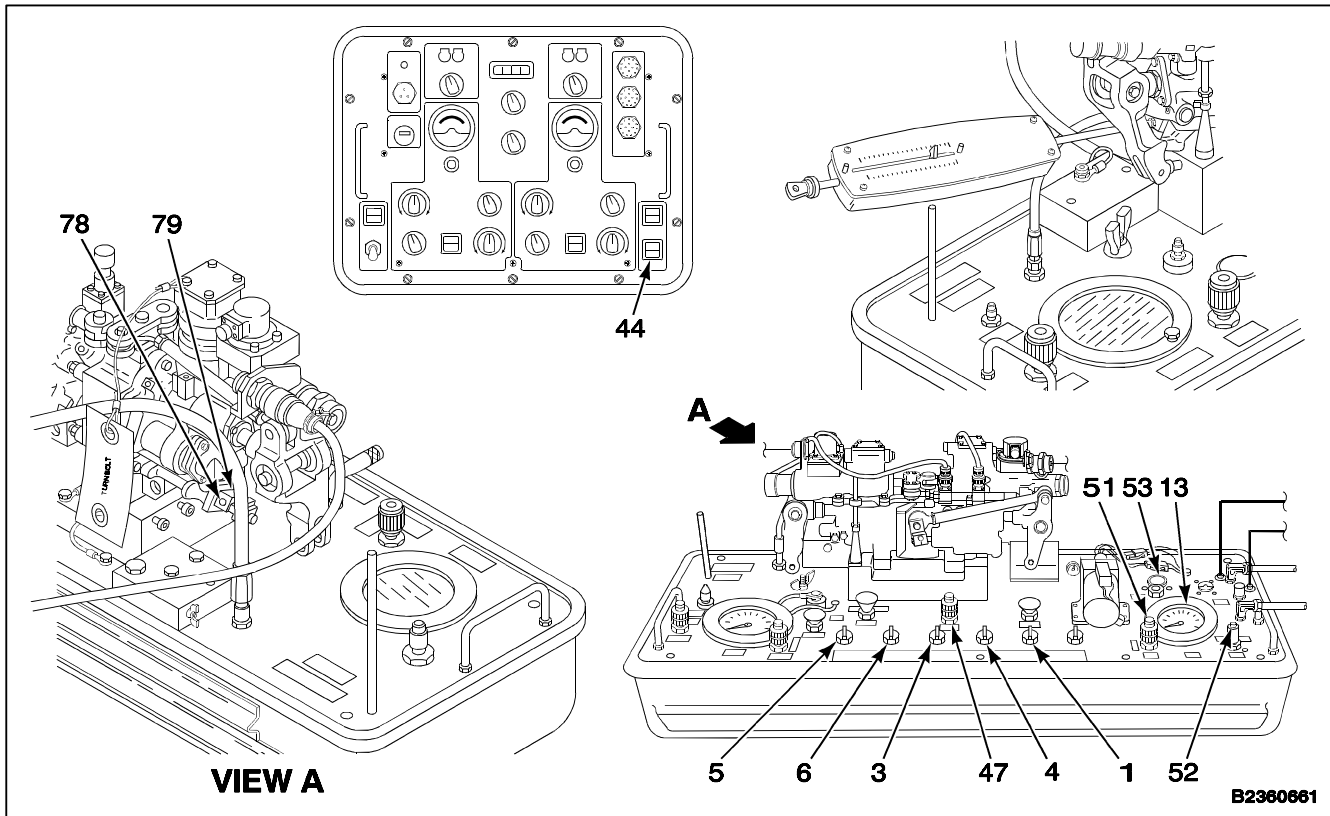

229. Remove post (76) from hydraulic unit.

WARNING

Carefully align and seat force gauge in jam simulation button before force is applied; otherwise, personal injury can result.

230. Apply **60 pounds** maximum to jam simulation button (80) of SYSTEM 1 with force gauge 145GS278-16 (81). Jam indicator button (78) shall extend.

NOTE

If jam indicator does not extend, stop test. Replace jam indicator assembly and repeat steps 220 thru 224.

231. Set HIGH PRESS SHUTOFF valve (51) to CLOSE.

232. Set ILCA PRESS SYS 1 valve (1) to VENT.

233. Repeat steps 220 thru 224 **three times**. Jam indicator button (78) shall remain extended.

234. Press jam indicator button (78). Button shall remain flush with valve (79) body.

235. Set ILCA PRESS SYS 1 valve (1) to PRESS.

236. Slowly turn HIGH PRESS SHUTOFF valve (51) to OPEN.

237. Manually operate input arm (61). Jam indicator button (78) shall remain flush with valve (79) body.

238. Set HIGH PRESS SHUTOFF valve (51) to CLOSE.

239. Set ILCA PRESS SYS 1 valve (1) to VENT, then to OFF.

240. Install post (76).

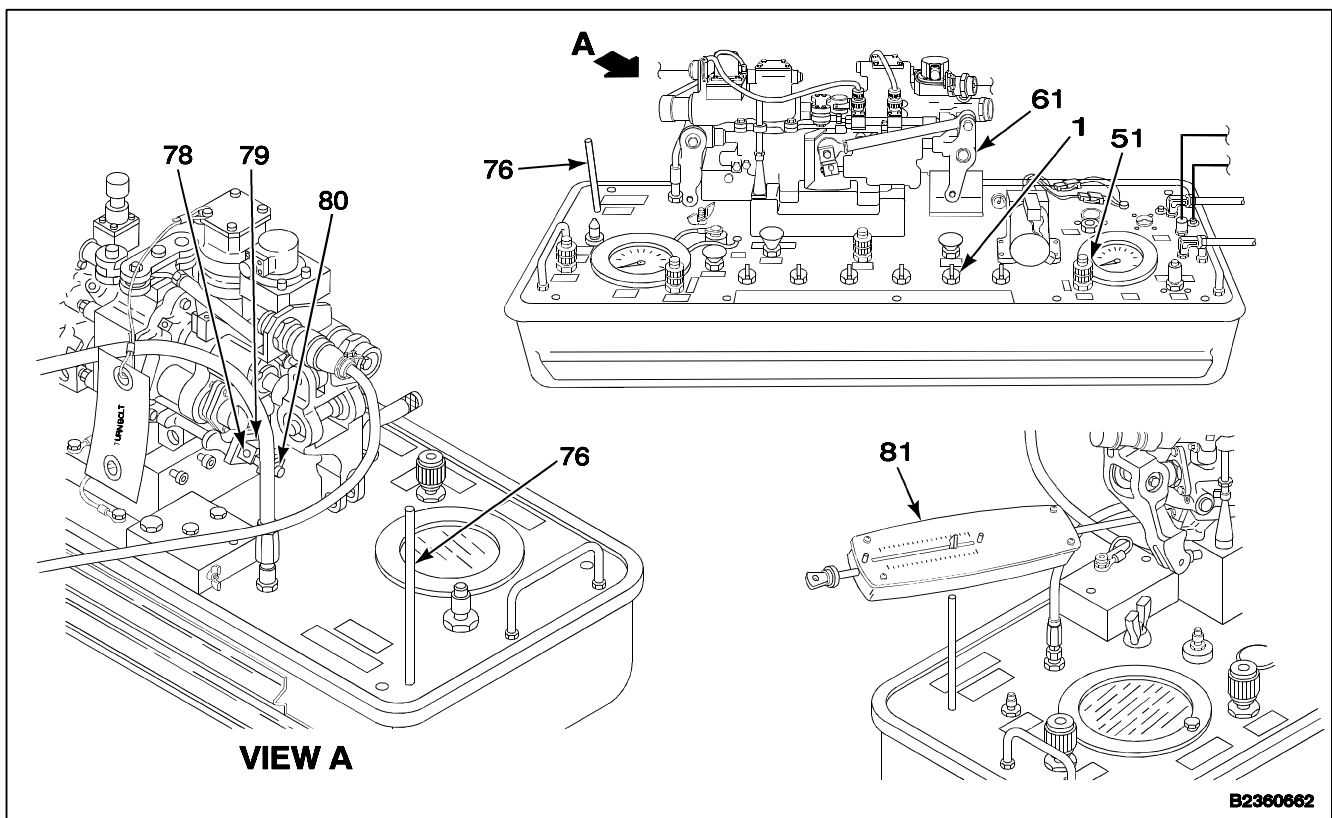

241. Set ILCA PRESS SYS 2 valve (2) to PRESS.
242. Slowly turn HIGH PRESS SHUTOFF valve (51) to OPEN.
243. Set HIGH PRESS SHUTOFF valve (51) to CLOSE.
244. Set ILCA PRESS SYS 2 valve (2) to VENT.
245. Repeat steps 240 thru 243 **three times**. Jam indicator button (82) shall remain flush with valve (83) body.
246. Set ILCA PRESS SYS 2 valve (2) to PRESS.
247. Slowly turn HIGH PRESS SHUTOFF valve (51) to OPEN.
248. Apply **60 pounds** maximum to jam simulation button (80) of SYSTEM 2 with force gauge 145GS278-16 (81). Jam indicator button (82) shall be extended.
249. Set HIGH PRESS SHUTOFF valve (51) to CLOSE.
250. Set ILCA PRESS SYS 2 valve (2) to VENT.
251. Repeat steps 240 thru 243 **three times**. Jam indicator button (82) shall remain extended.

NOTE

If jam indicator does not extend, stop test and replace jam indicator assembly. Repeat steps 241 thru 248.



Carefully align and seat force gauge in jam simulation button before force is applied; otherwise, personal injury can result.

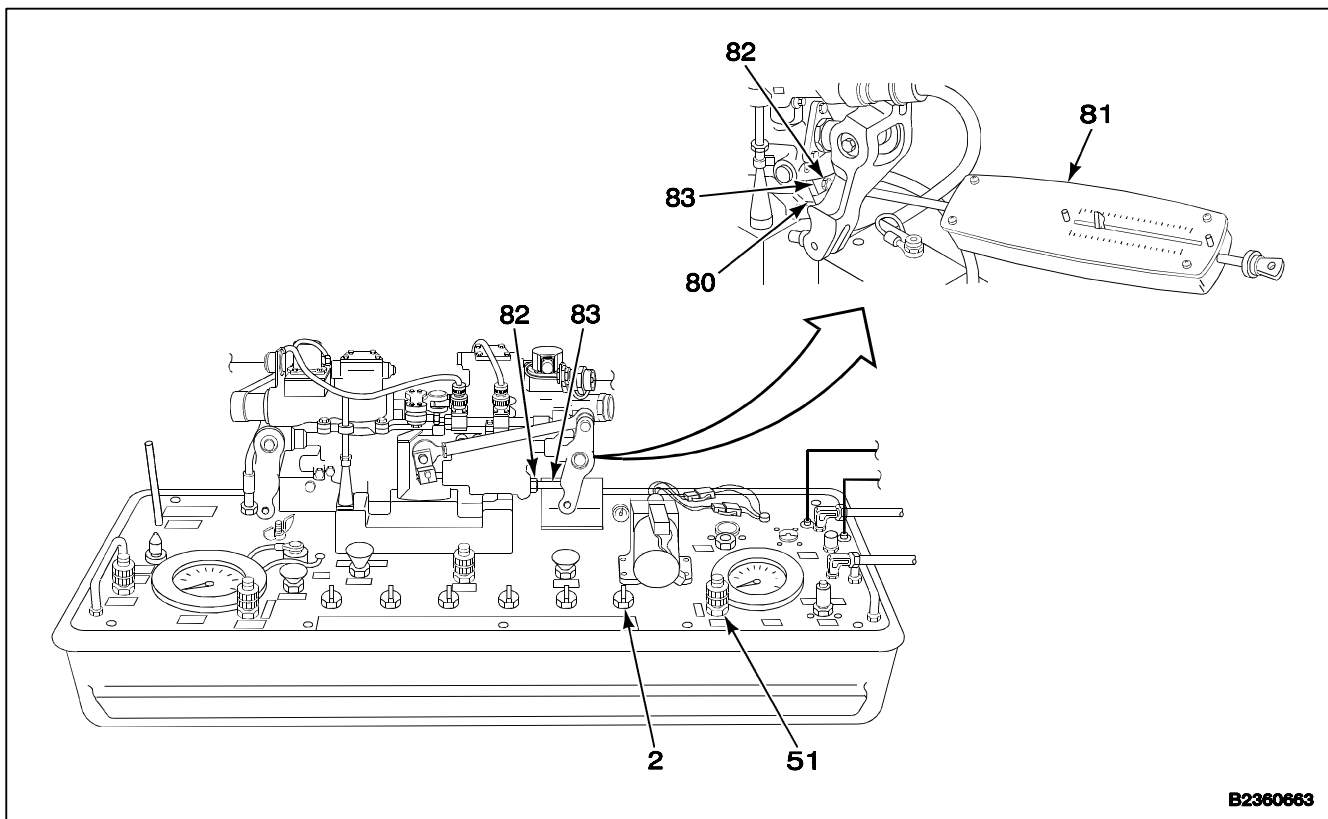

B2360663

7-98 TEST PITCH, ROLL, YAW, OR THRUST INTEGRATED LOWER CONTROL ACTUATOR (ILCA) (AVIM) (Continued)

- 252. Press jam indicator button (82). Button shall remain flush with valve (83) body.
- 253. Set ILCA PRESS SYS 2 valve (2) to PRESS.
- 254. Slowly turn HIGH PRESS SHUTOFF valve (51) to OPEN.
- 255. Manually operate input arm (61). Jam indicator button (82) shall remain flush with valve 3 (83) body.
- 256. Set electrical and hydraulic unit controls as follows:
 - q. HIGH PRESS REGULATOR valve (52) to DECREASE.
 - b. SOLENOID SHUTOFF switch (44) to CLOSE.
 - c. SOLENOID VALVE (53) to CLOSED.
- d. Press and hold HIGH PRESS RELIEF VALVE (67) and LOW PRESS RELIEF VALVE (68) until HIGH PRESS gauge (13) indicates **0 psi**.
- e. HIGH PRESS SHUTOFF valve (51) to CLOSE.
- f. ILCA PRESS SYS 2 valve (2) to OFF.
- g. SAS PRESS SYS 1 valve (3), SAS PRESS SYS 2 valve (4), RETURN SYS 1 valve (5), and RETURN SYS 2 valve (6) to OFF.
- 257. If no further testing is required, perform normal shutdown (TM 55-4920-428-13).

END VALVE JAM INDICATOR TEST

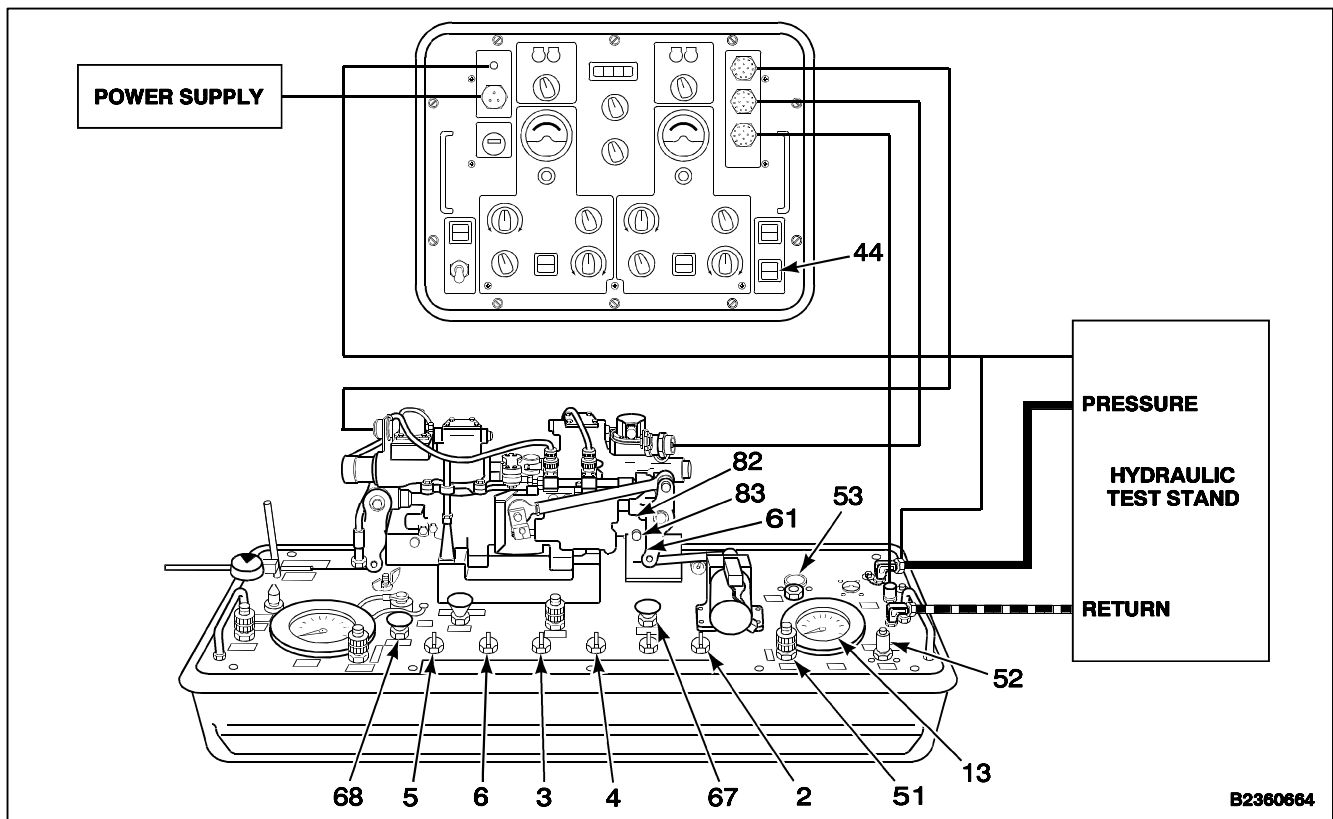

B2360664

TEST 15

CASE CAVITY LEAKAGE TEST (ALL)

258. Perform steps 1 thru 40. Check initial control and valve setting in steps 22 and 23.

259. Set electrical and hydraulic unit controls as follows:

- a. Check RETURN SHUTOFF VALVE (47) is OPEN.
- b. RETURN SYS 1 valve (5) and RETURN SYS 2 valve (6) to RETURN.
- c. SOLENOID valve (53) to OPENED.
- d. SOLENOID SHUTOFF switch (44) to OPEN.
- e. Slowly turn HIGH PRESS REGULATOR (52) toward INCREASE until HIGH PRESS gauge (13) indicates **1500 psi**.

f. ILCA PRESS SYS 1 valve (1) and ILCA PRESS SYS 2 valve (2) to PRESS.

g. Slowly turn HIGH PRESS SHUTOFF valve (51) to OPEN.

260. Manually set input arm (61) at mid position.

261. Install PIN 2 (69) in input arm (61).

262. Set electrical and hydraulic unit controls as follows:

- a. HIGH PRESS SHUTOFF valve (51) to CLOSE.
- b. ILCA PRESS SYS 1 valve (1) and ILCA PRESS SYS 2 valve (2) to VENT.
- c. HIGH PRESS REGULATOR valve (52) to DECREASE.
- d. SOLENOID SHUTOFF switch (44) to CLOSE.
- e. SOLENOID valve (53) to CLOSED.

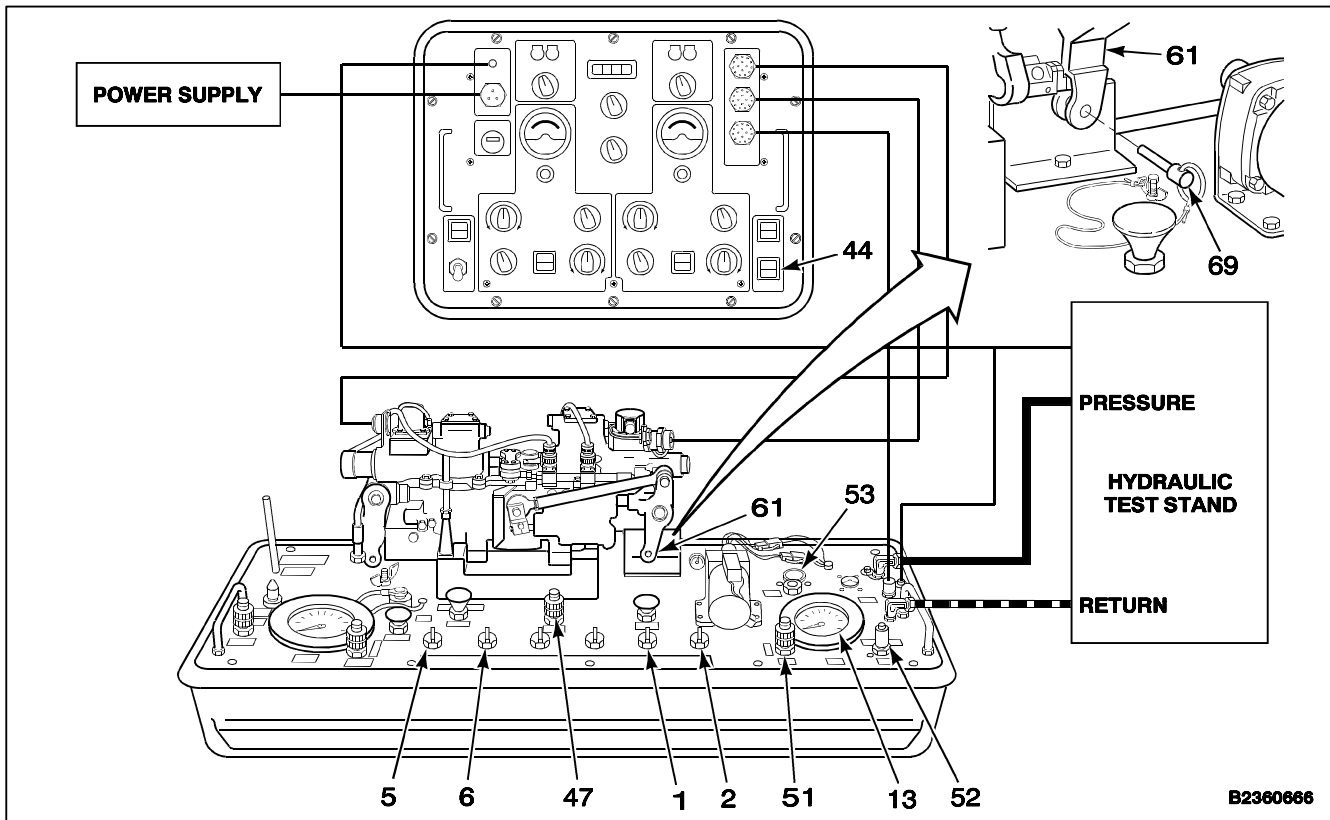

7-98 TEST PITCH, ROLL, YAW, OR THRUST INTEGRATED LOWER CONTROL ACTUATOR (ILCA) (AVIM) (Continued)

7-98

263. Remove lockwire from relief valve (85) of SYSTEM 1.
264. Remove valve (85) and packing (86). Use cloths (E135) for spilled fluid.
265. Remove case vent adapter 145GS278-14 (87) from stowed position and install in valve port (88) of SYSTEM 1.
266. Torque adapter (87) to **17 inch-pounds**.
267. Remove cap (89) from adapter (87) and stow.
268. Set electrical and hydraulic unit controls as follows:
- SOLENOID valve (53) to OPEN.
 - SOLENOID SHUTOFF switch (44) to OPEN.
 - Slowly turn HIGH PRESS REGULATOR valve (52) toward INCREASE until HIGH PRESS gage (13) indicates **1500 psi**.

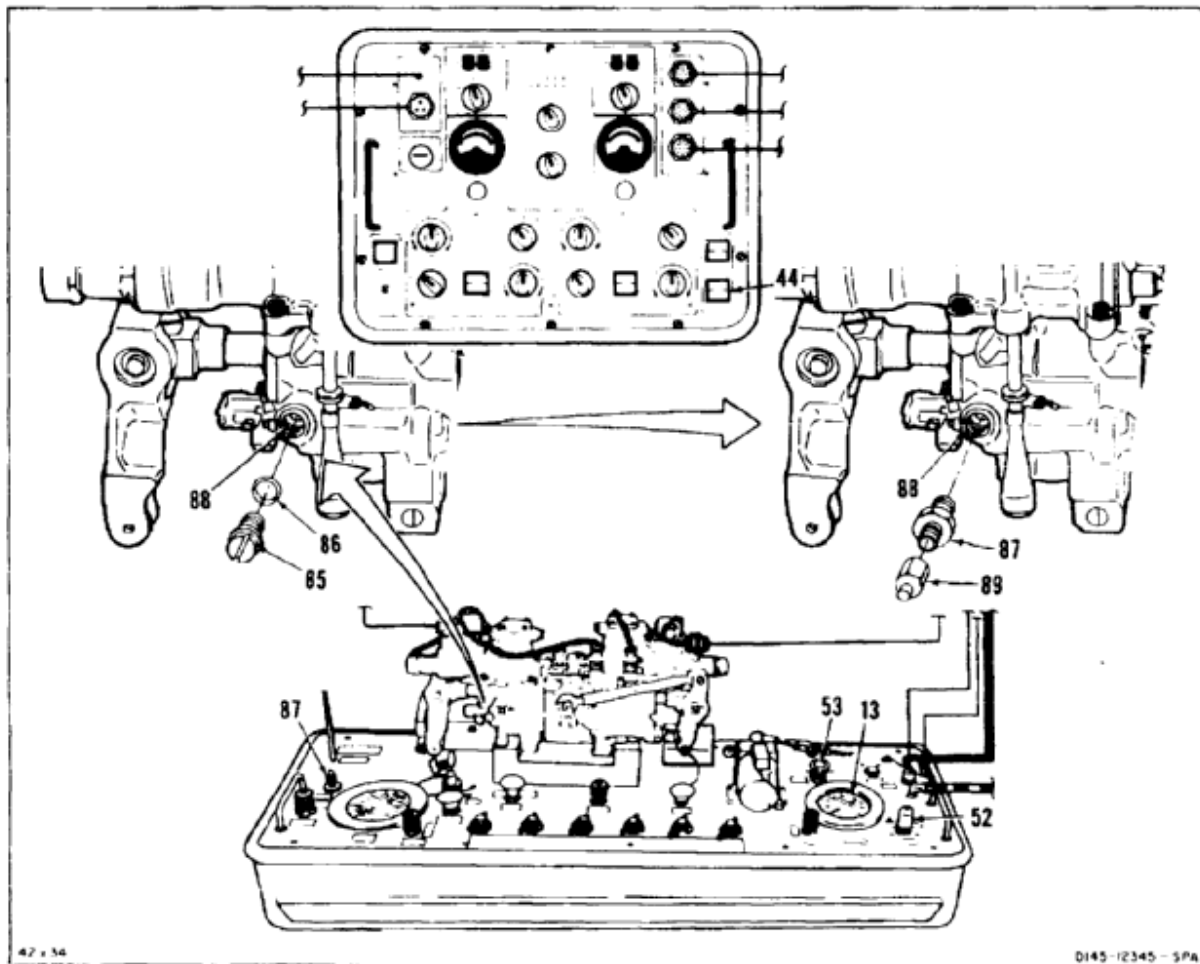

7-98 TEST PITCH, ROLL, YAW, OR THRUST INTEGRATED LOWER CONTROL ACTUATOR (ILCA) (AVIM) (Continued)

- d. ILCA PRESS SYS 1 valve (1) to PRESS.
- e. Slowly turn HIGH PRESS SHUTOFF valve (51) to OPEN.
- 269. Observe adapter (87) for **5 minutes**. When first drop appears, start to time leak rate. Leak rate shall not exceed **3 drops per minute**. Use cloths (E135) for spilled fluid. Wear gloves (E184.1).
- 270. Set HIGH PRESS SHUTOFF valve (51) to CLOSE.
- 271. Set ILCA PRESS SYS 1 valve (1) to VENT.
- 272. Install cap (89) on adapter (87). Remove adapter and stow. Use cloths (E135) for spilled fluid. Wear gloves (E184.1).
- 273. Install valve (85) and packing (86) in port (88).
- 274. Torque valve (85) to **17 inch-pounds**.

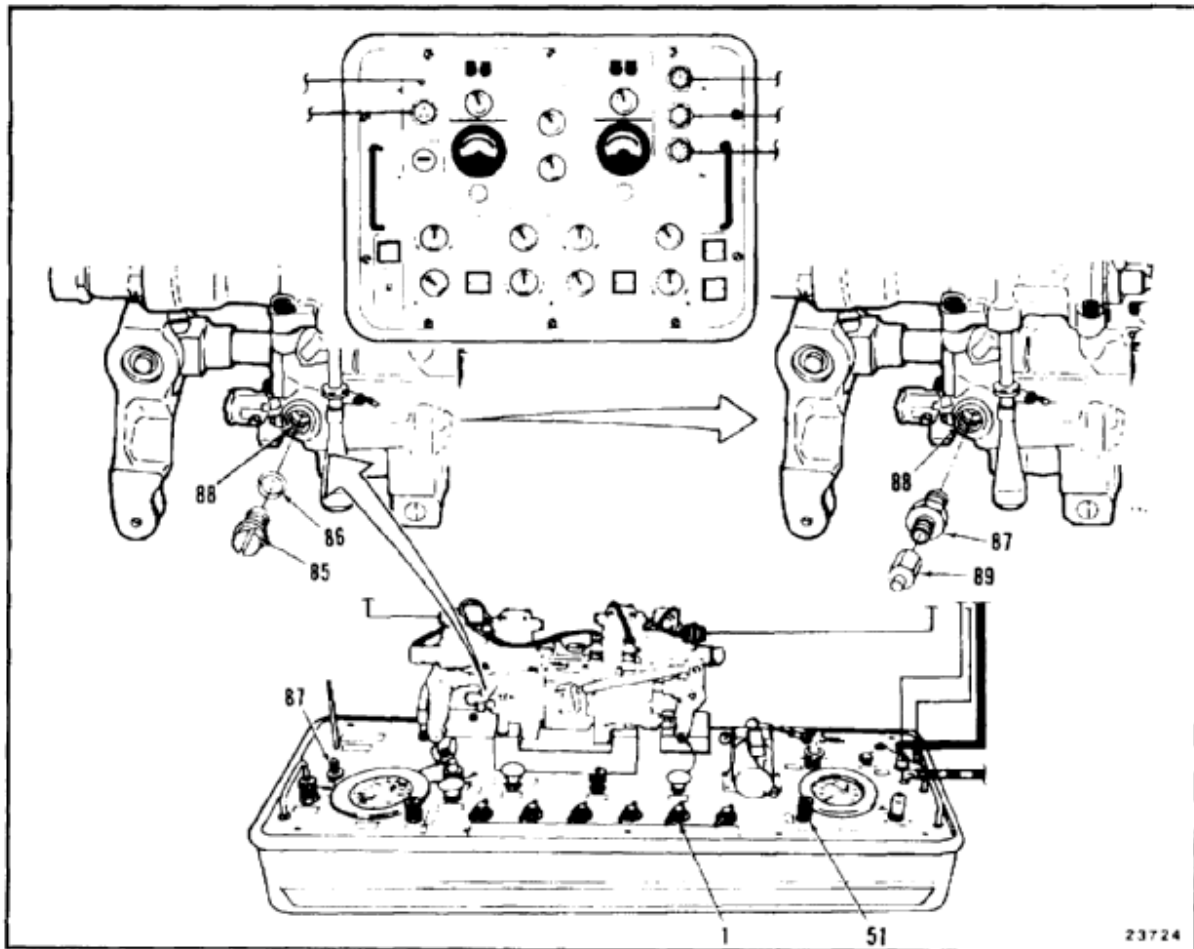

7-98 TEST PITCH, ROLL, YAW, OR THRUST INTEGRATED LOWER CONTROL ACTUATOR (ILCA) (AVIM) (Continued)

- 275. Remove lockwire from valve (90) of SYSTEM 2.
- 276. Remove valve (90) and packing (91). Use cloths (E135) for spilled fluid. Wear gloves (E184.1).
- 277. Remove case vent adapter 145GS278-14 (87) from stowed position and install in valve port (92) of SYSTEM 2.
- 278. Torque adapter (87) to **17 inch-pounds**.
- 279. Remove cap (89) from adapter (87) and stow.
- 280. Set ILCA PRESS SYS 2 valve (2) to PRESS.
- 281. Slowly turn HIGH PRESS SHUTOFF valve (51) to OPEN.
- 282. Observe adapter (87) for leaks for **5 minutes**. When first drop appears start to time leak. Leak rate shall not exceed **3 drops per minute**. Use cloths (E135) for spilled fluid. Wear gloves (E184.1).
- 283. Set electrical and hydraulic unit as follows:
 - a. HIGH PRESS REGULATOR valve (52) to DECREASE.
 - b. SOLENOID SHUTOFF switch (44) to CLOSE.
 - c. SOLENOID VALVE (53) to CLOSED.
 - d. Press HIGH PRESS RELIEF VALVE (67) and hold until HIGH PRESS gauge (13) indicates **0 psi**.
 - e. HIGH PRESS SHUTOFF valve (51) to CLOSE.
 - f. ILCA PRESS SYS 2 valve (2) to VENT, then to OFF.
 - g. ILCA PRESS SYS 1 valve (1) to VENT, then to OFF.
 - h. RETURN SYS 1 valve (5) and RETURN SYS 2 valve (6) to OFF.

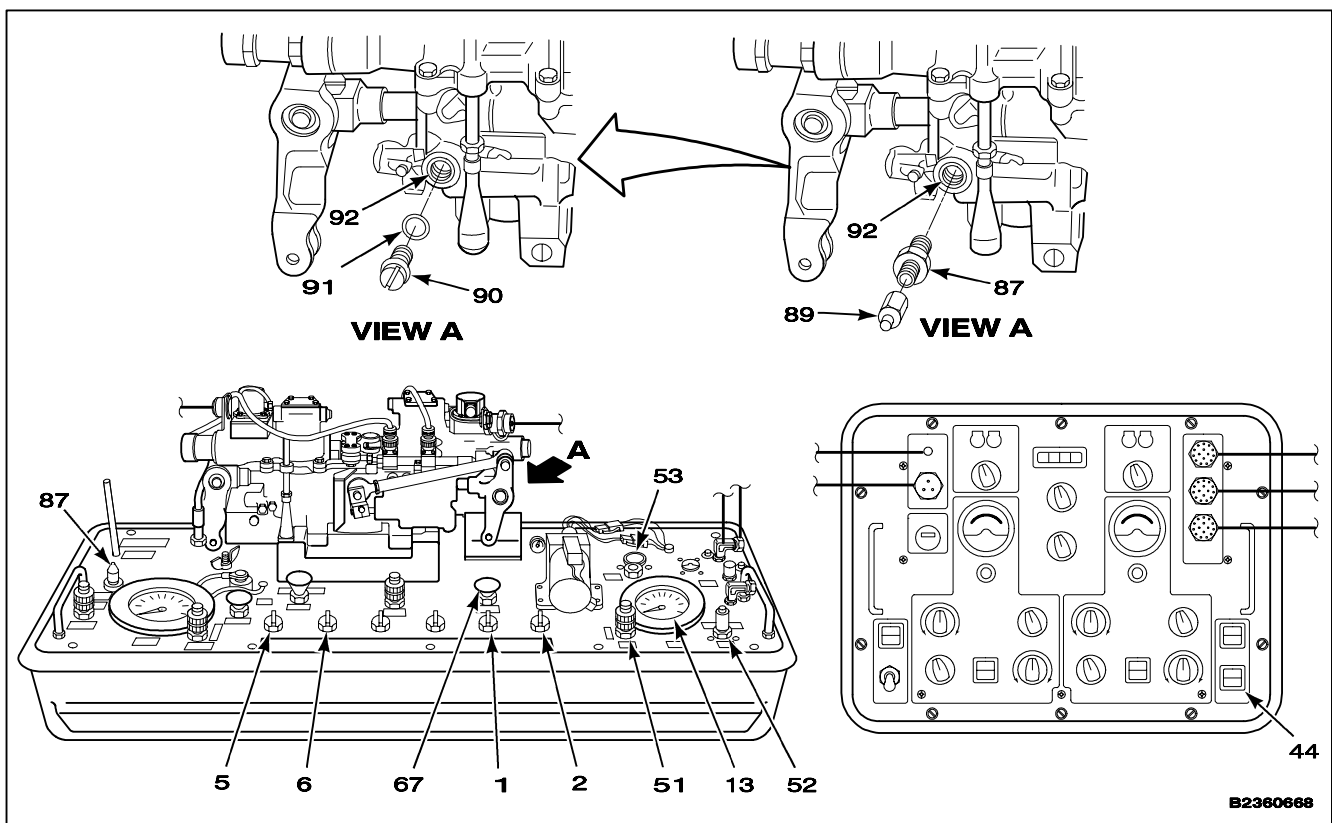

284. Install cap (89) on adapter (87). Remove adapter and stow. Use cloths (E135) for spilled fluid. Wear gloves (E184.1).

285. Remove PIN 2 (69) from input arm (61).

286. If relief valve testing is not required, perform the following:

- a. Install valve (90) and packing (91) in port (92).
- b. Torque valve (90) to **17 inch-pounds**.
- c. Apply a bead of sealant (E336) around perimeter of valve (85) and valve (90). Wear gloves (E184.1).

d. Lockwire valve (85) and valve (90). Use lockwire (E231).

287. If no further testing is required, perform normal shutdown (TM 55-4920-248-13).

INSPECT

END CASE CAVITY LEAK TEST

NOTE

Valve (85) and valve (90) are removed in Test 16, Relief Valve Test (ALL).

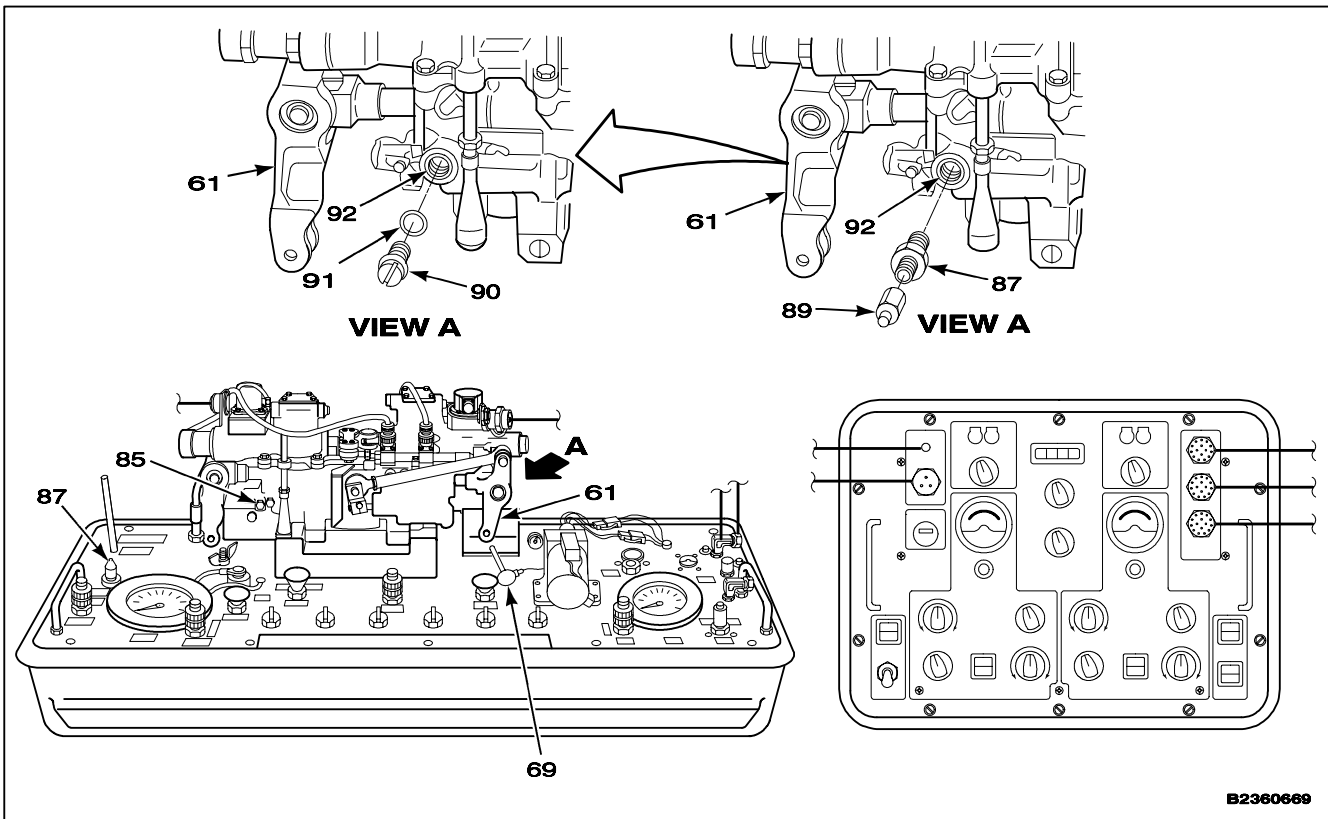

B2360669

TEST 16

RELIEF VALVE TEST (ALL)

288. Perform steps 1 thru 40. Check initial control and valve settings in steps 22 and 23.

NOTE

If relief valve was not replaced in Test 15, omit step 289.

289. Remove relief valve (90) of system 2 as follows:

- a. Remove lockwire from valve (90).
- b. Remove valve (90) and packing (91). Use cloths (E135) for spilled fluid. Wear gloves (E184.1).
- c. Remove adapter (87) from stowed position and install it in port (92).
- d. Torque adapter (87) to **17 inch-pounds**.
- e. Remove cap (89).
- f. Remove plug (93).
- g. Connect hose (94) to adapter (87).

290. Set electrical and hydraulic unit controls as follows:

- a. SOLENOID valve (53) to OPENED.
- b. SOLENOID SHUTOFF switch (44) to OPEN.
- c. Slowly turn CASE VENT LINE PRESS VALVE (48) to OPEN.

291. Slowly turn LOW PRESS REGULATOR valve (50) towards INCREASE until relief valve (85) cracks and fluid flows from valve. Valve shall relieve at **160 to 190 psi**. Record reading.

292. Slowly turn LOW PRESS REGULATOR valve (50) towards DECREASE until flow from valve (85) stops. Flow shall stop when pressure is above **150 psi**. Record reading.

293. Repeat steps 291 and 292. Record cracking and reseating pressures. Compare readings.

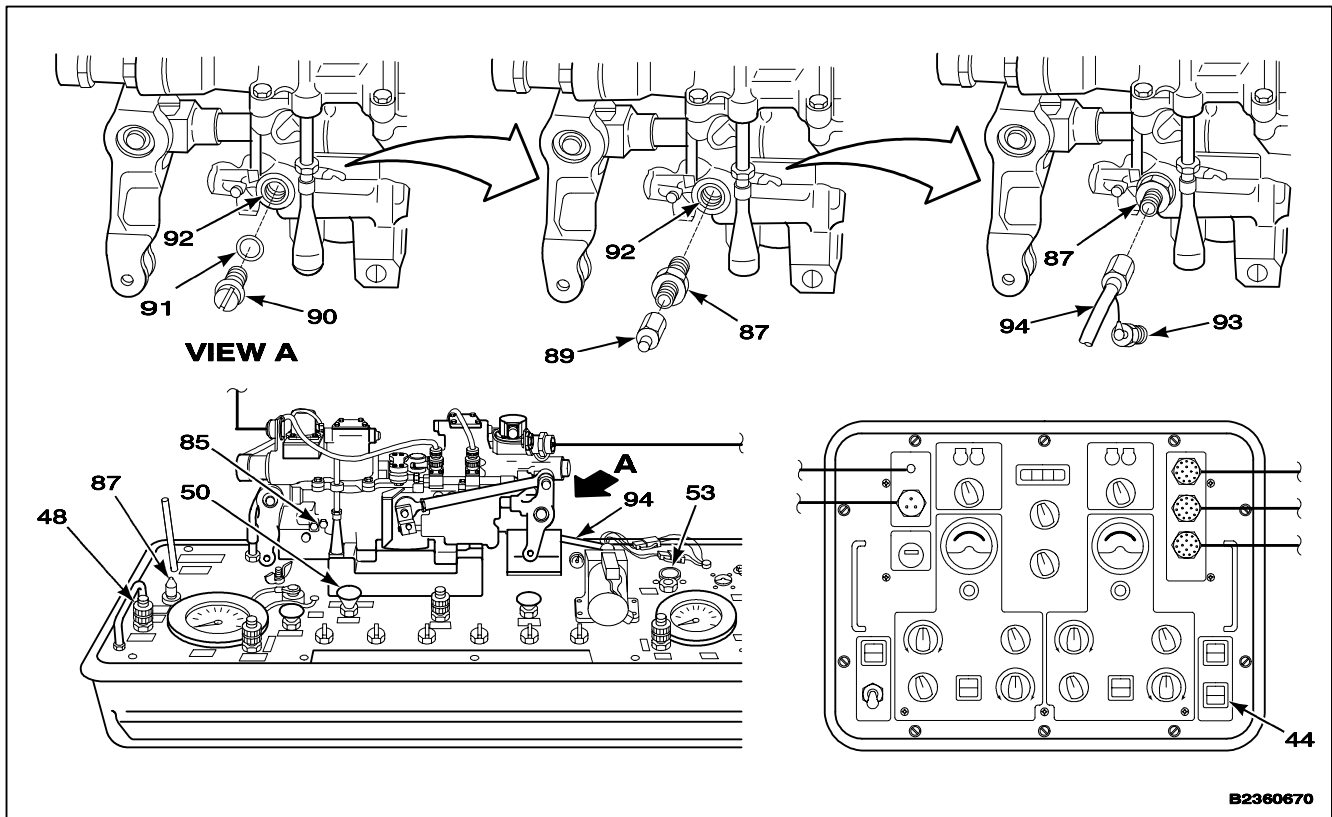

- 294. Set electrical and hydraulic unit controls as follows:
 - a. LOW PRESS REGULATOR valve (50) to DECREASE.
 - b. SOLENOID SHUTOFF switch (44) to CLOSE.
 - c. SOLENOID valve (53) to CLOSED.
 - d. Press LOW PRESS RELIEF VALVE (68) and HIGH PRESS RELIEF VALVE (67). Hold until LOW PRESS gauge (13) indicates **0 psi**. Release valves.
 - e. CASE VENT LINE PRESS valve (48) to CLOSE.
- 295. Disconnect hose (94) from adapter (87). Cap hose with plug (93). Use cloths (E135) for spilled fluid. Wear gloves (E184.1).
- 296. Remove adapter (87), install cap (89), and stow.

- 297. Install valve (90) and packing (91) in port (92).
- 298. Torque valve (90) to **17 inch-pounds**.

WARNING

Sealant (E336) can irritate skin and cause burns. Avoid contact with skin, eyes, or clothing. In case of contact, immediately flush skin or eyes with water for at least **15 minutes**. Get medical attention for eyes.

- 299. Apply a bead of sealant (E336) around perimeter of valve (90). Wear gloves (E184.1).
- 300. Lockwire valve (90). Use lockwire (E231).

INSPECT

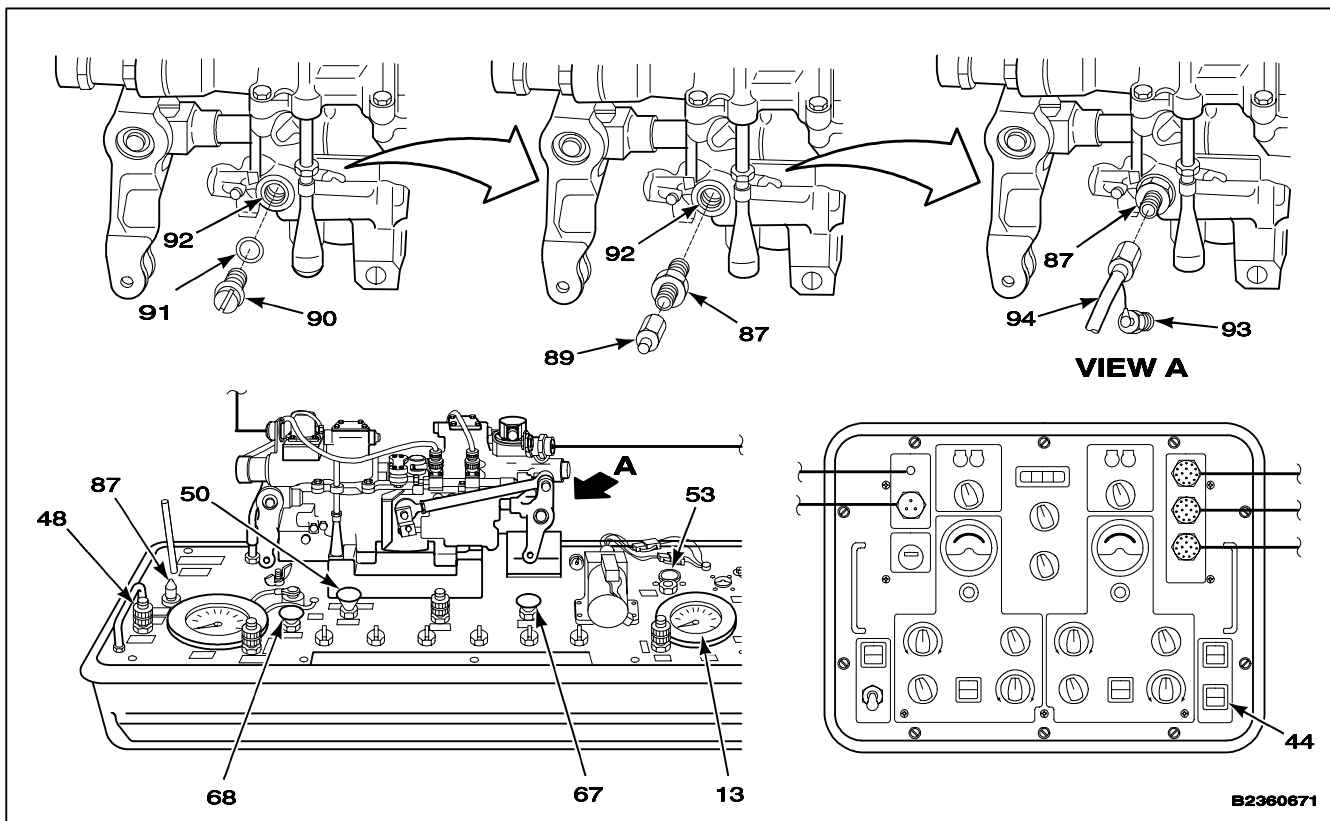

7-98 TEST PITCH, ROLL, YAW, OR THRUST INTEGRATED LOWER CONTROL ACTUATOR (ILCA) (AVIM) (Continued)

301. Remove valve (85) and packing (86). Use cloths (E135) for spilled fluid. Wear gloves (E184.1).
302. Install adapter (87) in port (88). Remove cap (89).
303. Torque adapter (87) to **17 inch-pounds**.
304. Remove plug (93). Connect hose (94) to adapter (87).
305. Set hydraulic unit controls as follows:
 - a. SOLENOID valve (53) to OPEN.
 - b. SOLENOID SHUTOFF switch (44) to OPEN.
 - c. Slowly turn CASE VENT LINE PRESS valve (48) to OPEN.
306. Slowly turn LOW PRESS REGULATOR valve (50) toward INCREASE until relief valve (90) cracks and fluid flows from valve. Record LOW PRESSURE (14) when flow starts. Valve shall relieve at **160 to 190 psi**.
307. Slowly turn LOW PRESS REGULATOR valve (50) towards DECREASE until flow from valve (90) stops. Record LOW PRESSURE (14) when flow stops. Flow shall stop before pressure drops to **150 psi**.
308. Repeat steps 305 thru 307. Compare results.
309. Set electrical and hydraulic unit controls as follows:
 - a. Turn LOW PRESS REGULATOR valve (50) to DECREASE.
 - b. SOLENOID SHUTOFF switch (44) to CLOSE.
 - c. SOLENOID valve (53) to CLOSED.
 - d. CASE VENT LINE PRESS valve (48) to CLOSE.
310. Disconnect hose (94) from adapter (87). Install plug (93) in hose. Use cloths (E135) for spilled fluid. Wear gloves (E184.1).
311. Install cap (89) on adapter (87). Remove adapter and stow.
312. Install valve (85) and packing (86) in port (88).
313. Torque valve (85) to **17 inch-pounds**.

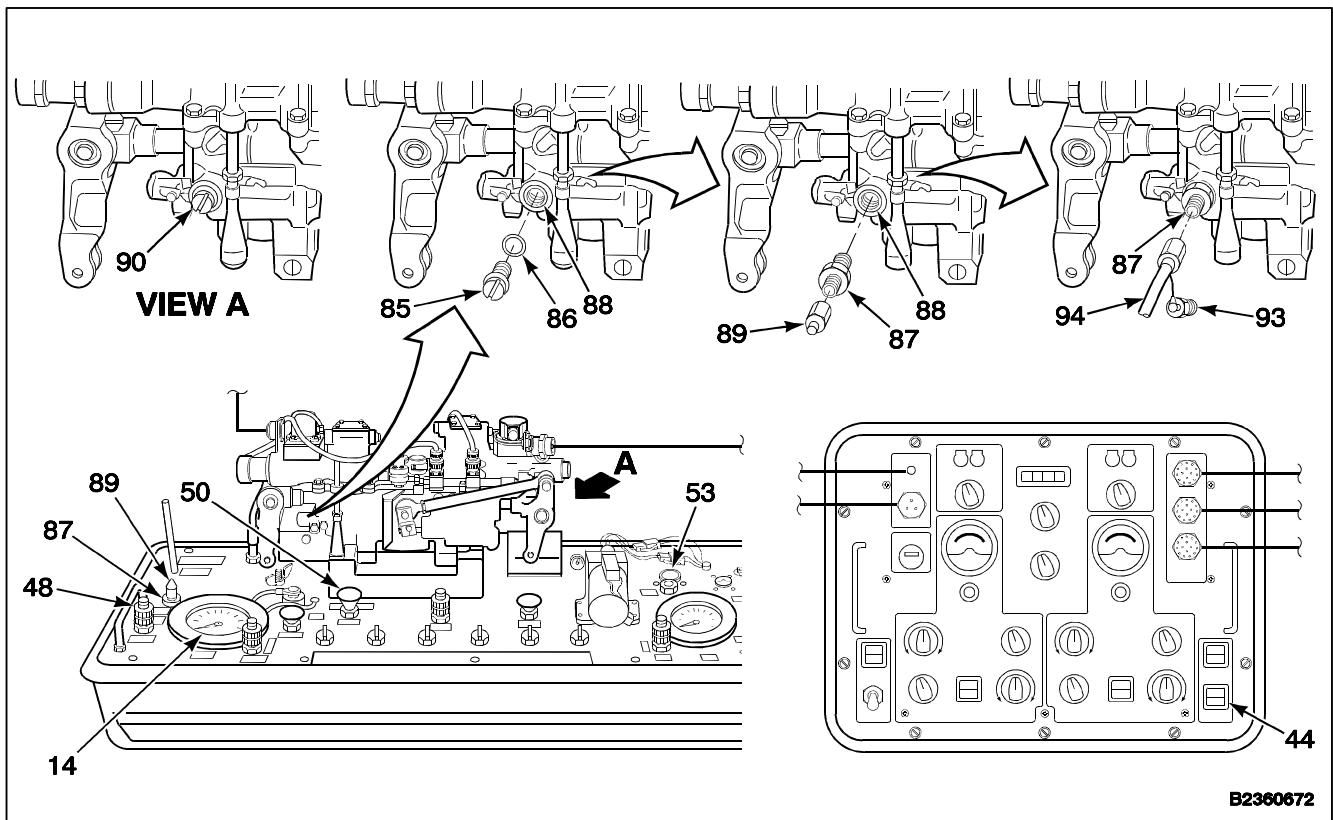

B2360672

WARNING

Sealant (E336) can irritate skin and cause burns. Avoid contact with skin, eyes, or clothing. In case of contact, immediately flush skin or eyes with water for at least **15 minutes**. Get medical attention for eyes.

314. Apply a bead of sealant (E336) around perimeter of valve (85). Wear gloves (E184.1).
315. Lockwire valve (85). Use lockwire (E231).
316. If no further testing is required, perform normal shutdown. (Refer to TM 55-4920-428-13.)

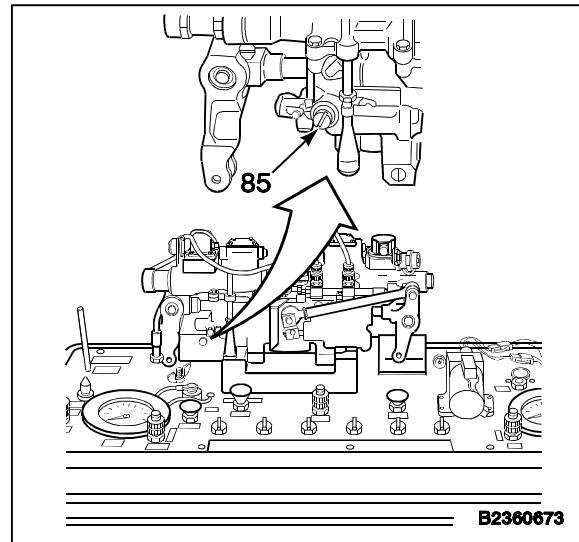
**INSPECT****END RELIEF VALVE TEST**

TEST 17

EXTERNAL DYNAMIC LEAKAGE TEST (SPARE)

317. Perform steps 1 thru 40. Check initial control and valve settings in steps 22 and 23.



Tests 2, 3, 4 and 5 **MUST** be performed before this test; otherwise, damage to equipment may result.

318. Set electrical and hydraulic unit controls as follows:

- a. Check RETURN SHUTOFF valve (47) is OPEN.
- b. RETURN SYS 1 valve (5) and RETURN SYS 2 valve (6) to RETURN.
- c. SOLENOID valve (53) to OPENED.
- d. SOLENOID SHUTOFF switch (44) to OPEN.
- e. Slowly turn HIGH PRESS REGULATOR valve (52) toward INCREASE until HIGH PRESS gauge (13) indicates **1500 psi**.
- f. ILCA PRESS SYS 1 valve (1) and ILCA PRESS SYS 2 valve (2) to PRESS.

g. Slowly turn HIGH PRESS SHUTOFF valve (51) to full OPEN.

- 319. If dial indicator (9) is not installed, go to steps 93 thru 95.
- 319.1. Install PIN 2 (69) in input arm (61).
- 320. Set SAS 1 FUNCTION SELECT switch (30) to SQ WAVE.
- 321. Set SAS 1 SQ WAVE control (36) to MIN.
- 322. Set SAS PRESS SYS 1 valve (3) to PRESS.
- 323. Slowly turn SAS 1 SQ WAVE control (36) toward MAX until indicator (9) indicates about **0.30 inch** travel.
- 323.1. Allow link to complete **50 cycles** minimum. Check for **1 drop per 50 cycles** at the extensible link output seal.

NOTE

If leakage exceeds **1 drop in 50 cycles**, replace seals or extensible link.

- 324. Set SAS 1 FUNCTION SELECT switch (30) to CLSD LOOP.
- 325. Set SAS PRESS SYS 1 valve (3) to VENT then to OFF.

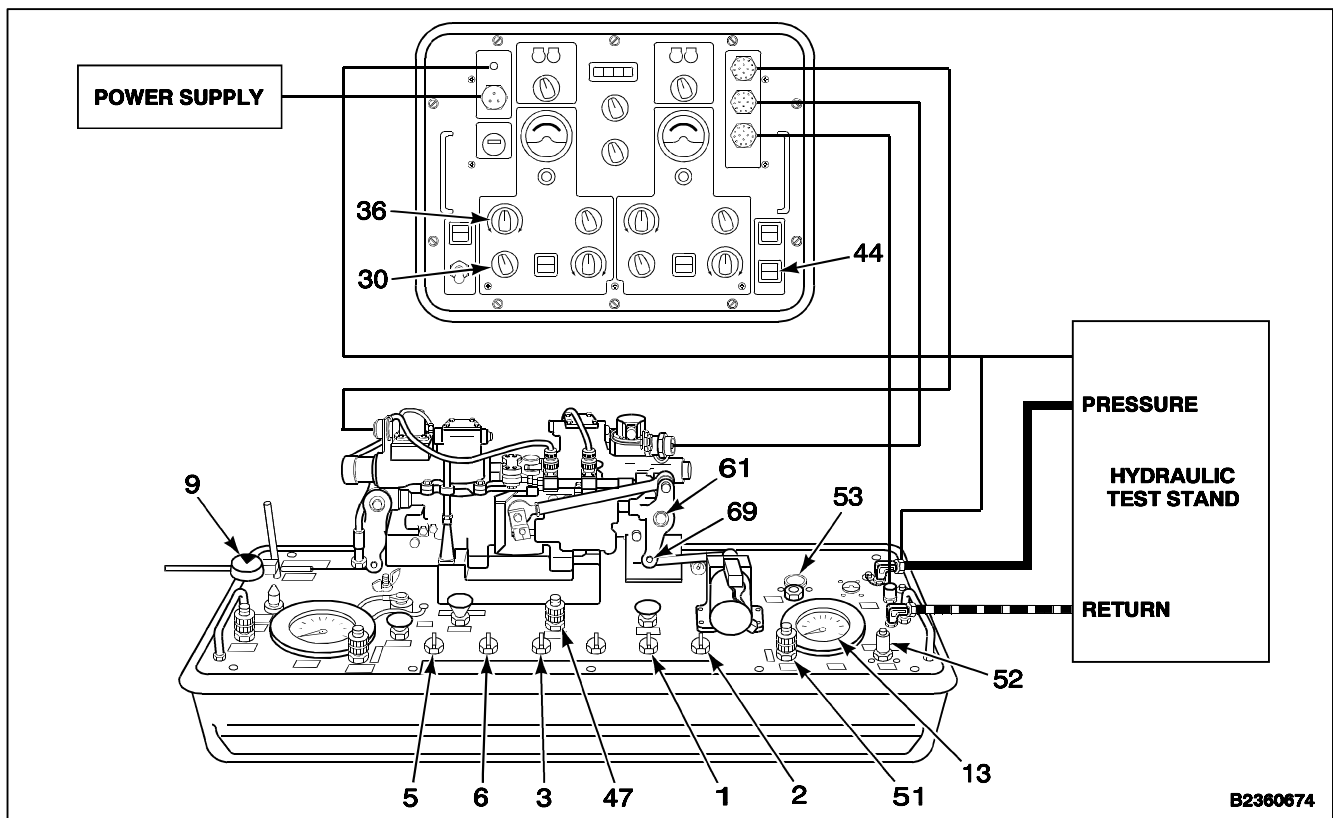

- 326. Set SAS 2 FUNCTION SELECT switch (31) to SQ WAVE.
- 327. Set SAS 2 SQ WAVE control (37) to MIN.
- 328. Set SAS PRESS SYS 2 valve (4) to PRESS.
- 329. Slowly turn SAS 2 SQ WAVE control (37) toward MAX until indicator (9) indicates about **0.30 inch** travel.
- 329.1. Allow link to complete **50 cycles** minimum. Check for **1 drop per 50 cycles** at the extensible link output seal.

NOTE

If leakage exceeds **1 drop in 50 cycles**, replace seals or extensible link.

- 330. Set SAS 2 FUNCTION SELECT switch (31) to CLSD loop.
- 331. Set SAS PRESS SYS 2 valve (4) to VENT, then OFF.
- 332. Remove PIN 2 (69) from arm (61) and stow.
- 333. Unstow cycle motor linkage (64). Position linkage in input arm (61).
- 334. Remove PIN 1 (65) from stowage. Install PIN 1 (65) in arm (61) and linkage (64).

NOTE

Bring cycle motor arm bearing into alignment with input arm from above.

- 335. Remove and stow indicator (9), PIN 3 (73), and bearing (75).
- 336. Set SAS PRESS SYS 1 valve (3) and SAS PRESS SYS 2 valve (4) to PRESS.
- 337. Set SAS 1 FUNCTION SELECT switch (30) and SAS 2 FUNCTION SELECT switch (31) to SQ WAVE.
- 338. Press CYCLE MOTOR switch (45) ON. Run cycle motor for **15 minutes**. Then run it for **50 cycles**.

NOTE

Motor runs at about **20 cycles per minute**. **50 cycles** take about **2.5 minutes**.

- 339. Check actuator (11) for leaks. Dynamic seals shall not exceed **1 drop in 50 cycles**. There shall be no leaks at static seals or relief valves.

NOTE

If leakage exceeds **1 drop in 50 cycles**, replace seals.

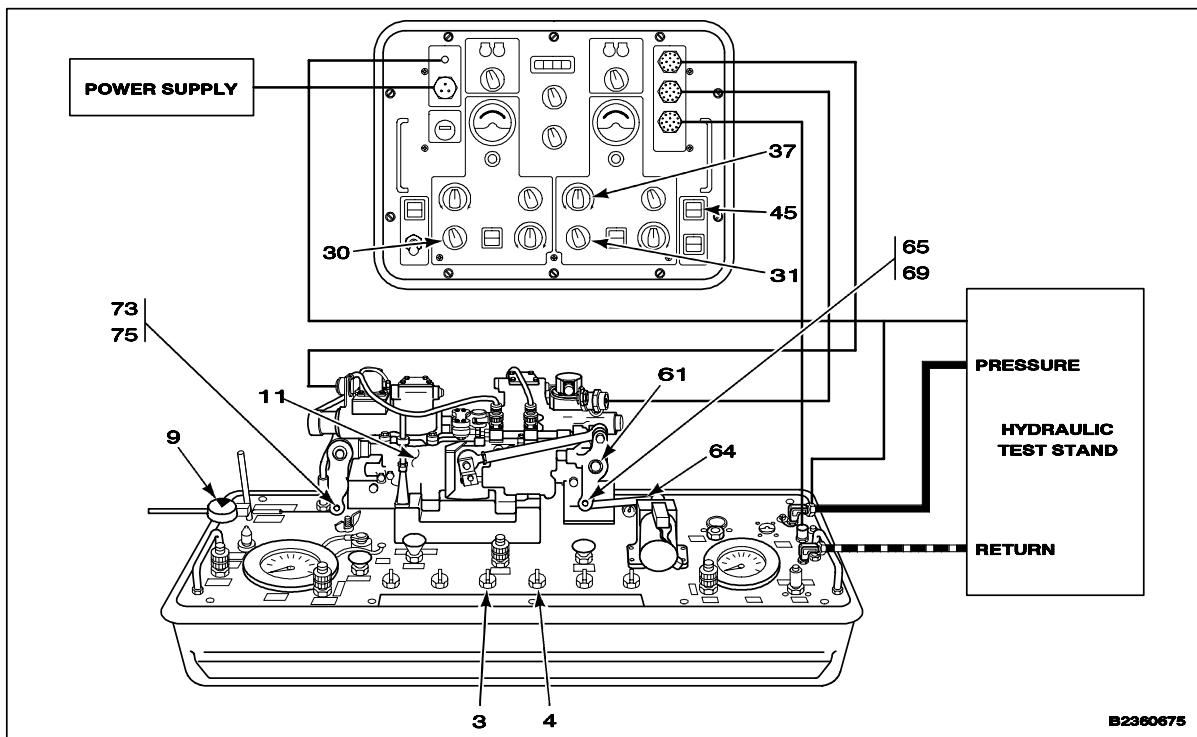

B2380675

7-98 TEST PITCH, ROLL, YAW, OR THRUST INTEGRATED LOWER CONTROL ACTUATOR (ILCA) (AVIM) (Continued)

- 340. Press CYCLE MOTOR switch (45) to OFF.
- 341. Set SAS 1 SQ WAVE control (36) and SAS 2 SQ WAVE control (37) to MIN.
- 342. Set SAS 1 FUNCTION SELECT switch (30) and SAS 2 FUNCTION SELECT switch (31) to BALANCE.
- 343. Set electrical and hydraulic unit control as follows:
 - a. HIGH PRESS REGULATOR valve (52) to DECREASE.
 - b. SOLENOID SHUTOFF switch (44) to CLOSE.
 - c. SOLENOID valve (53) to CLOSED.
 - d. ILCA PRESS SYS 1 valve (1), ILCA PRESS SYS 2 valve (2), SAS PRESS SYS 1 valve (3), and SAS PRESS SYS 2 valve (4) to VENT.
- e. HIGH PRESS SHUTOFF valve (51) to CLOSE.
- f. Press and hold HIGH PRESS RELIEF VALVE (67) for **15 seconds**.
- g. ILCA PRESS SYS 1 valve (1), ILCA PRESS SYS 2 valve (2), SAS PRESS SYS 1 valve (3), SAS PRESS SYS 2 valve (4), RETURN SYS 1 valve (5), and RETURN SYS 2 valve (6) to OFF.
- 344. Remove and stow PIN 1 (65) and cycle motor linkage (64).
- 345. If no further testing is required, perform normal shutdown (TM 55-4920-428-13).

END EXTERNAL DYNAMIC LEAKAGE TEST

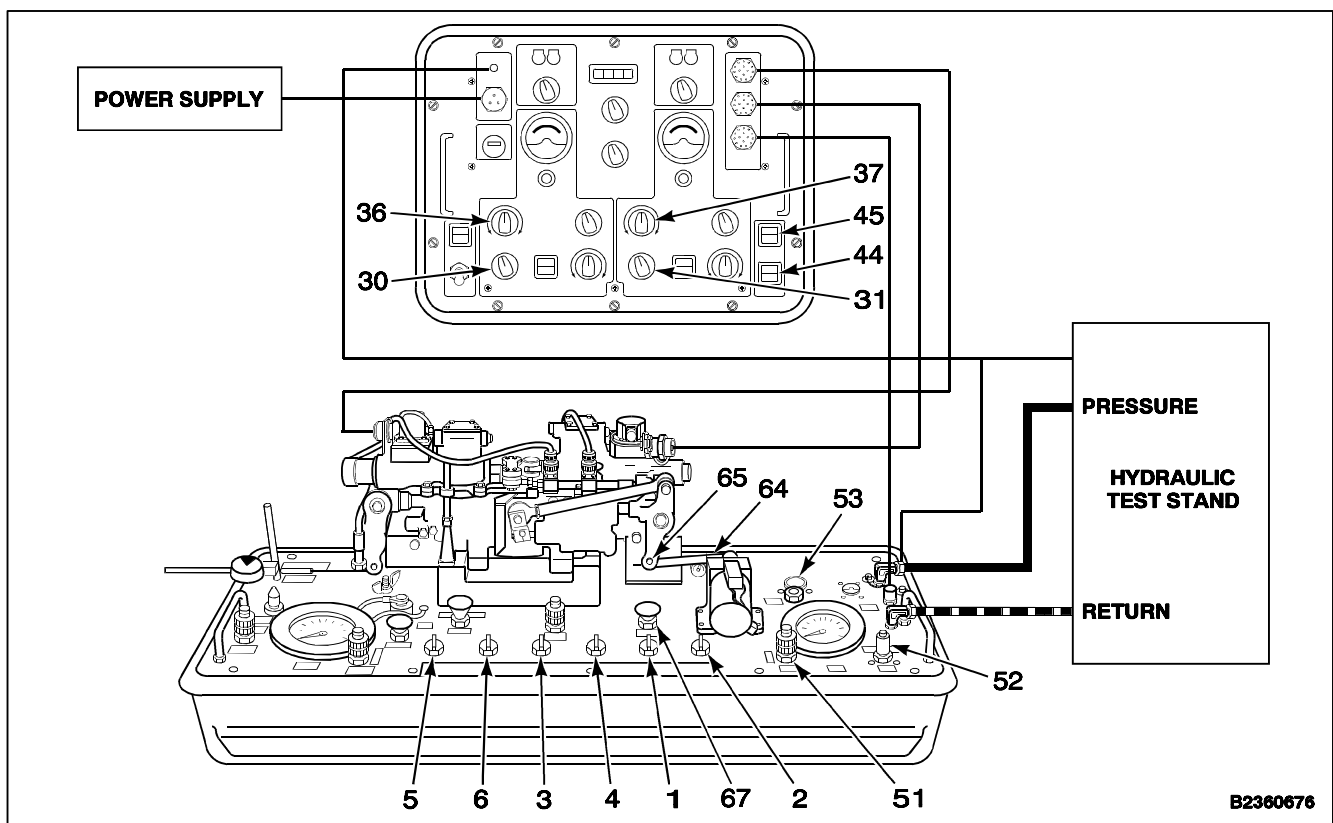

TEST 18

EXTERNAL STATIC LEAKAGE (ALL)

346. Perform steps 1 thru 40. Check initial control and valve settings in steps 22 and 23.

NOTE

Tests 2, 3, 4, and 5 **MUST** be performed before this test.

347. Set electrical and hydraulic unit controls as follows:

- a. Check RETURN SHUTOFF valve (47) is OPEN.
- b. SOLENOID valve (53) to OPEN.
- c. SOLENOID SHUTOFF switch (44) to OPEN.
- d. RETURN SYS 1 valve (5), RETURN SYS 2 valve (6) to PRESS.
- e. ILCA PRESS SYS 1 valve (1), ILCA PRESS SYS 2 valve (2), SAS PRESS SYS 1 valve (3), and SAS PRESS SYS 2 valve (4) to VENT.
- f. Slowly turn LOW PRESS REGULATOR valve (50) towards INCREASE until LOW PRESS gauge (14) indicates **60 psi**.

g. Slowly turn RETURN BACK PRESS valve (49) to OPEN.

348. Observe actuator (11) for **5 minutes**. Check for wetting of external seal and relief valve. Wetting shall not form **1 drop**.

349. Set electrical and hydraulic unit controls as follows:

- a. LOW PRESS REGULATOR valve (50) to DECREASE.
- b. SOLENOID SHUTOFF switch (44) to CLOSED.
- c. SOLENOID valve (53) to CLOSED.
- d. Press and hold LOW PRESS RELIEF VALVE (68) until LOW PRESS gauge (14) indicates **0 psi**.
- e. RETURN BACK PRESS valve (49) to CLOSE.
- f. RETURN SYS 1 valve (5) and RETURN SYS 2 valve (6) to RETURN.

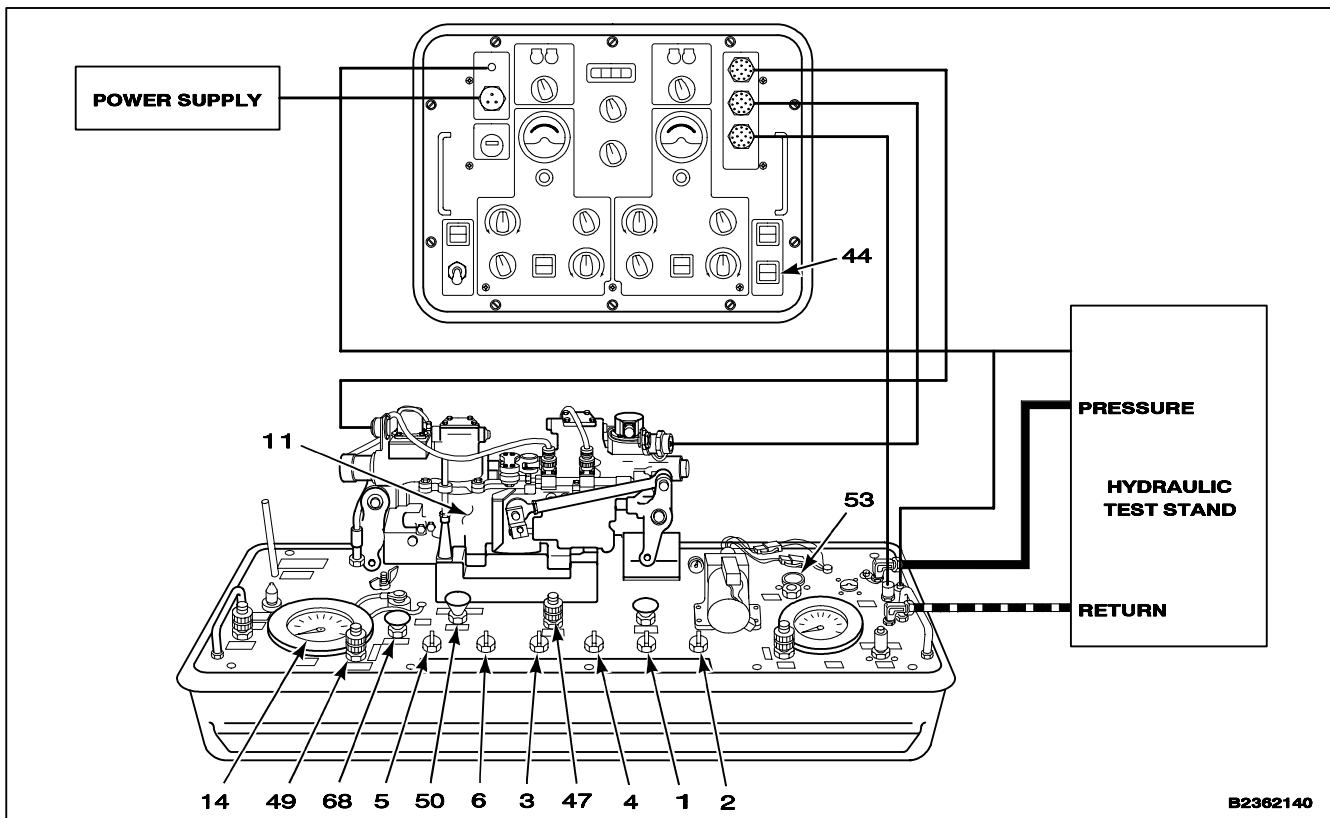

B2362140

- g. ILCA PRESS SYS 1 valve (1), ILCA PRESS SYS 2 valve (2), SAS PRESS SYS 1 valve (3), SAS PRESS SYS 2 valve (4), RETURN SYS 1 valve (5), and RETURN SYS 2 valve (6) to OFF.

350. If no further testing is required, perform normal shutdown (TM 55-4920-428-13).

END EXTERNAL STATIC LEAKAGE TEST

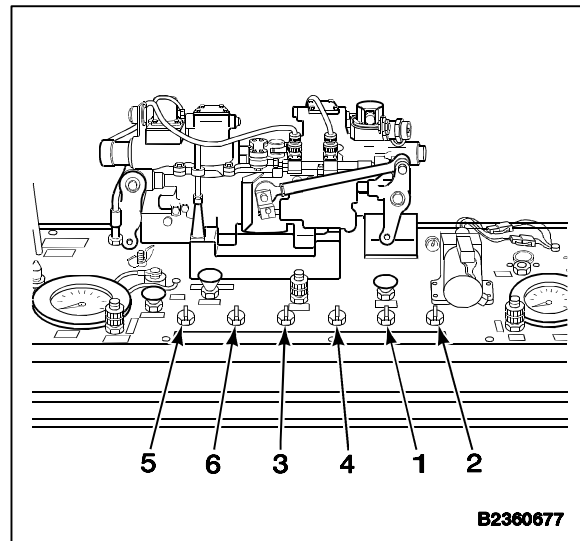

TEST 19

TEARDOWN PROCEDURE

351. Disconnect both ends of test cable 145GS278-5 (15). Stow cable in unit cover.

352. Disconnect both ends of test cable 145GS278-6 (18). Stow cable in unit cover.

352.1. Disconnect both ends of test cable 145GS278-7 (20.1). Stow cable in unit cover.

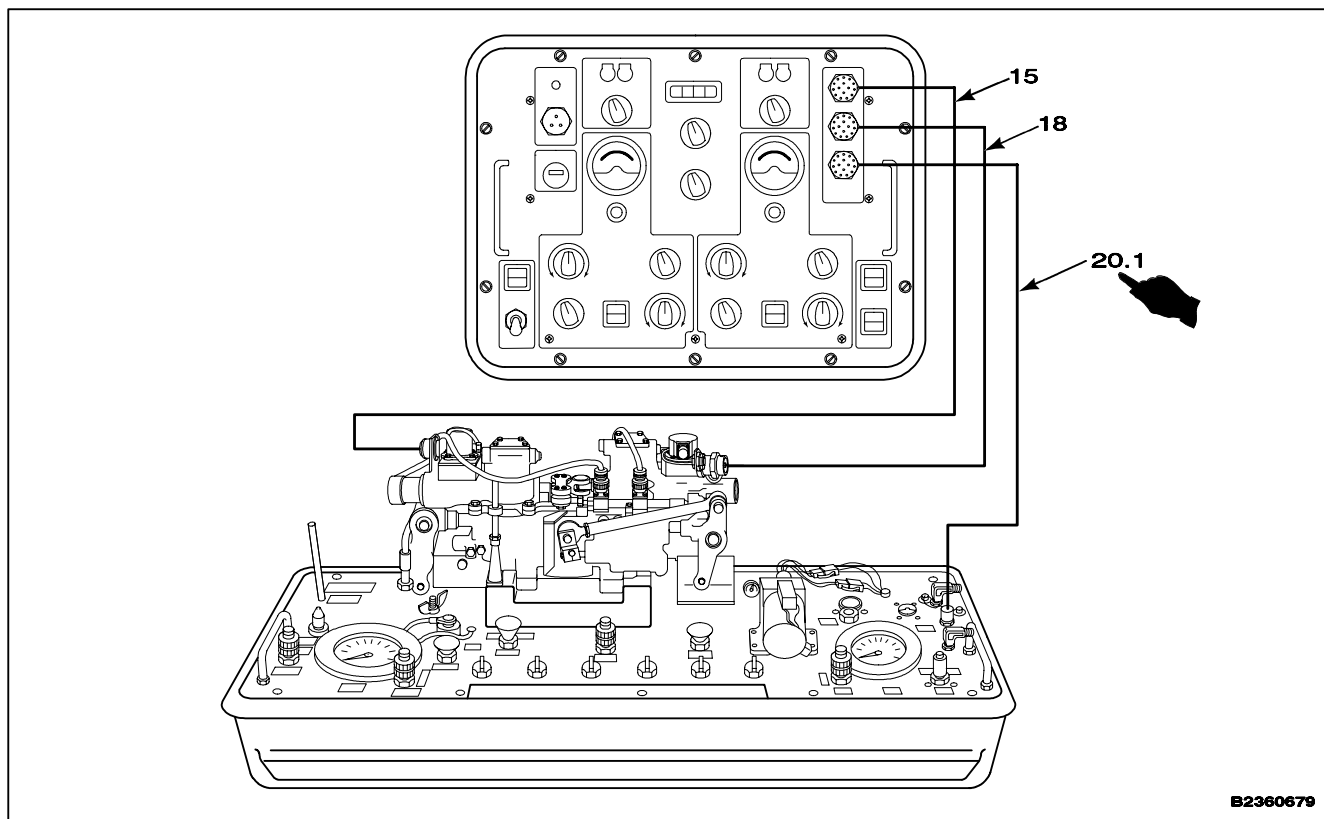

NOTE

Procedure is same to install No. 1 or No. 2 extensible link authority cover. Installation of No. 2 cover is shown here.

- 353. Remove two opposing screws (21).
- 354. Remove two screws (22) from manifold (23). Set wing nuts (24) against head of screws.
- 355. Install two screws (22) with wing nuts (24) in holes of screws (21). Tighten wing nuts against cover (26).
- 356. Remove remaining two screws (21).

WARNING

Cover is spring-loaded. Remove with caution; otherwise, personal injury can occur.

- 357. Loosen two wing nuts (24). Remove two screws (22).
- 358. Remove test cover 145GS278-12 (26). Stow cover in hydraulic unit cover.

WARNING

Acetone (E20) is extremely flammable. It can be toxic. Avoid inhaling. Use only with adequate ventilation. Avoid contact with skin, eyes, or clothing. Keep away from heat, sparks, or open flame. In case of contact, immediately flush skin or eyes with water for at least **15 minutes**. Get medical attention for eyes.

- 359. Clean authority cover (25) with acetone (E20). Remove tag. Wear gloves (E184.1).
- 360. Install packing (27) on cover (26). Position cover on No. 2 extensible link (28). Install screws (22). Tighten nuts (24).
- 361. Install two screws (21).
- 362. Remove two screws (22) and wing nuts (24) and stow.
- 363. Install remaining two screws (21).
- 364. Lockwire screws (21). Use lockwire (E231).

INSPECT

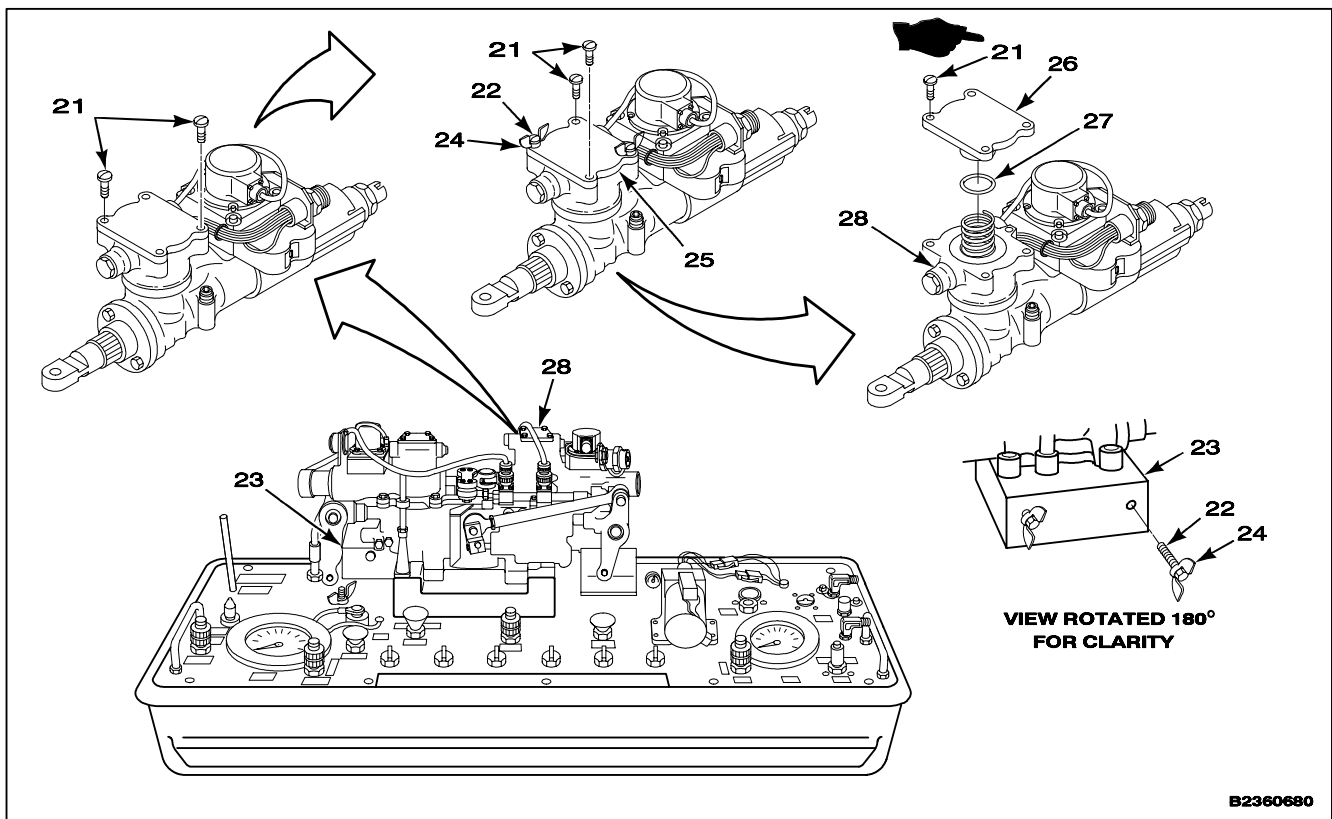

B2360680

- 365. Repeat steps 353 thru 364 for No. 1 extension link (54).
- 366. Stow screws (22) with wing nuts (24) in manifold (23).
- 367. Loosen four screws (10).
- 368. Remove actuator (11) from manifold (8).
- 369. Install dial indicator (9) on manifold (8) using thumbscrew (7).

- 370. Plug all ports and cap receptacles of actuator (11).

INSPECT

- 371. Disconnect and secure ILCA bench test set 145GS278-1 (TM 55-4920-428-13).

FOLLOW-ON MAINTENANCE:

None

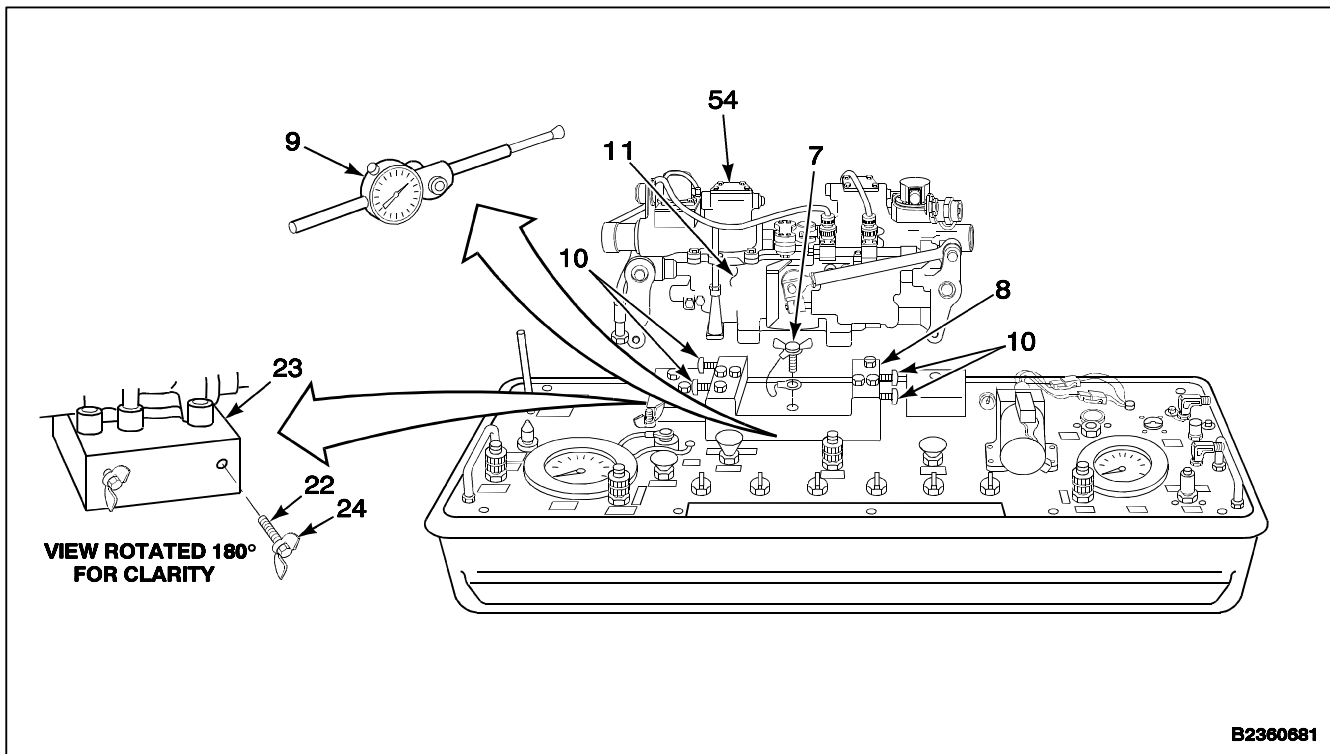

TEST 20

CENTERING SPRING TEST

- 372. Perform steps 1 thru 40.
- 373. POWER switch (28) to ON.
- 374. Set LINK TEST switch (29) to SELF FDBK.
- 375. Set electrical and hydraulic unit controls as follows:
 - a. Check RETURN SHUTOFF valve (38) is OPEN.
 - b. SOLENOID valve (50) to OPENED.
 - c. SOLENOID SHUTOFF switch (35) to OPEN.
 - d. RETURN SYS 1 valve (42) to RETURN.
 - e. Slowly turn HIGH PRESS regulator valve (49) towards INCREASE until HIGH PRESS gauge (51) indicates **1500 psi**.
 - f. Slowly turn HIGH PRESS SHUTOFF valve (48) to OPEN.
- 376. Set VALVE CONTROL (25) to EXTEND.
- 377. SAS PRESS SYS 1 valve (44) to PRESS.
- 378. Set SAS PRESS SYS 1 valve (44) to OFF. Piston shall return to center position within **1 second**.

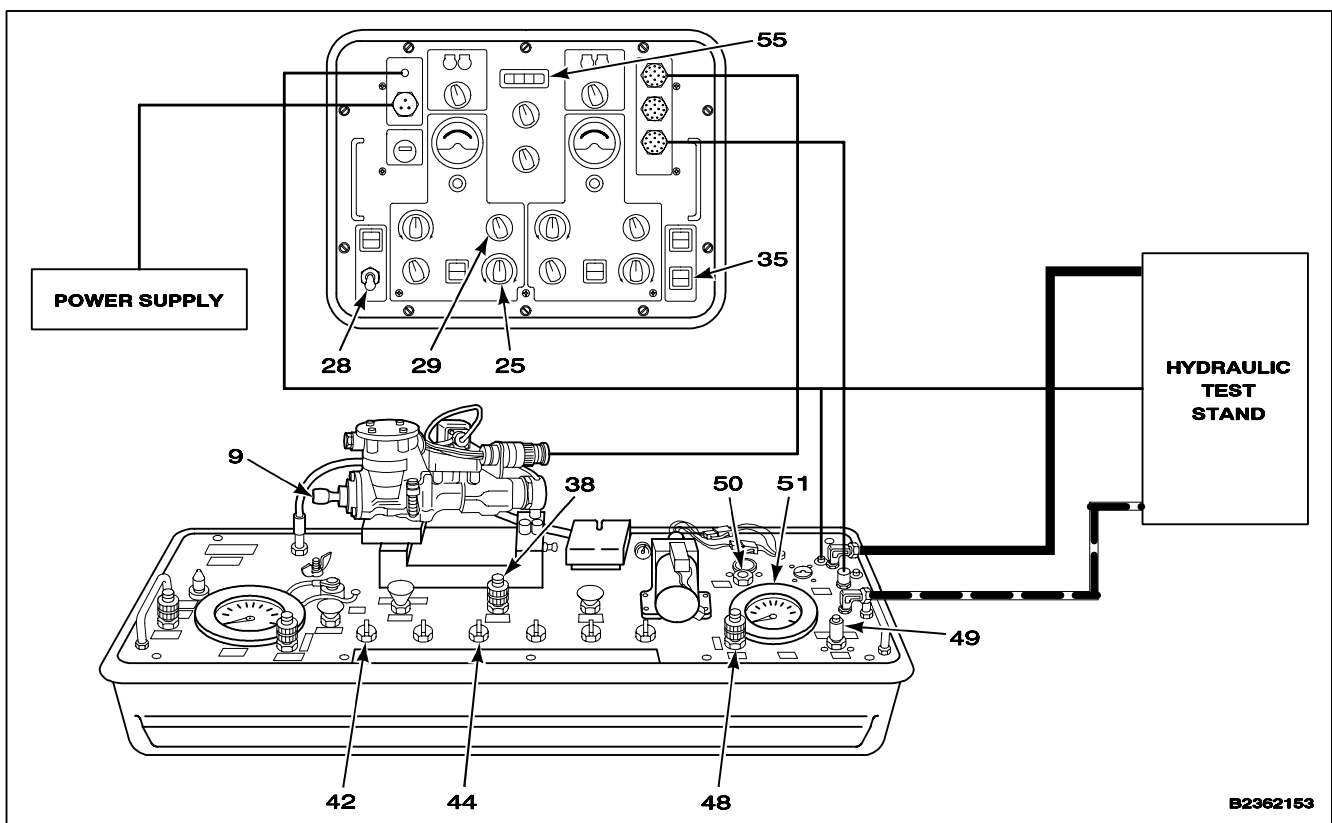

- 379. Record reading on DVM (55).
- 380. Repeat steps 377 thru 379 **three times**. Compare recorded readings with first reading. Readings must be within **0.0500** of first reading of step 379.
- 381. Set VALVE CONTROL (25) to RETRACT.
- 382. Set SAS PRESS SYS 1 valve (44) to PRESS.
- 383. Set SAS PRESS SYS 1 valve (44) to OFF. Piston (9) shall return to center position within **1 second**.
- 384. Record reading on DVM (55).
- 385. Repeat steps 382 and 383 **three times**. Compare recorded readings with first reading of step 384. Readings shall be within **0.500**.
- 386. Set electrical and hydraulic unit controls as follows:
 - a. HIGH PRESS REGULATOR valve (49) to DECREASE.
 - b. HIGH PRESS SHUTOFF valve (48) to CLOSE.
 - c. SOLENOID SHUTOFF switch (35) to CLOSE.
 - d. SOLENOID valve (50) to CLOSED.
 - e. SAS PRESS SYS 1 valve (44) to VENT.
 - f. Push and hold HIGH PRESS RELIEF valve (53) and LOW PRESS RELIEF valve (54) for **15 seconds**.
 - g. SAS PRESS SYS 1 valve (44) to OFF.
 - h. RETURN SYS 1 valve (42) to OFF.
- 387. Set electrical unit controls as follows:
 - a. VALVE CONTROL (25) to NULL.
 - b. LINK TEST switch (29) to VALVE.
- 388. If no further testing is required, perform normal shutdown (TM 55-4920-428-13).

END OF CENTERING SPRING TEST

FOLLOW-ON MAINTENANCE:

None

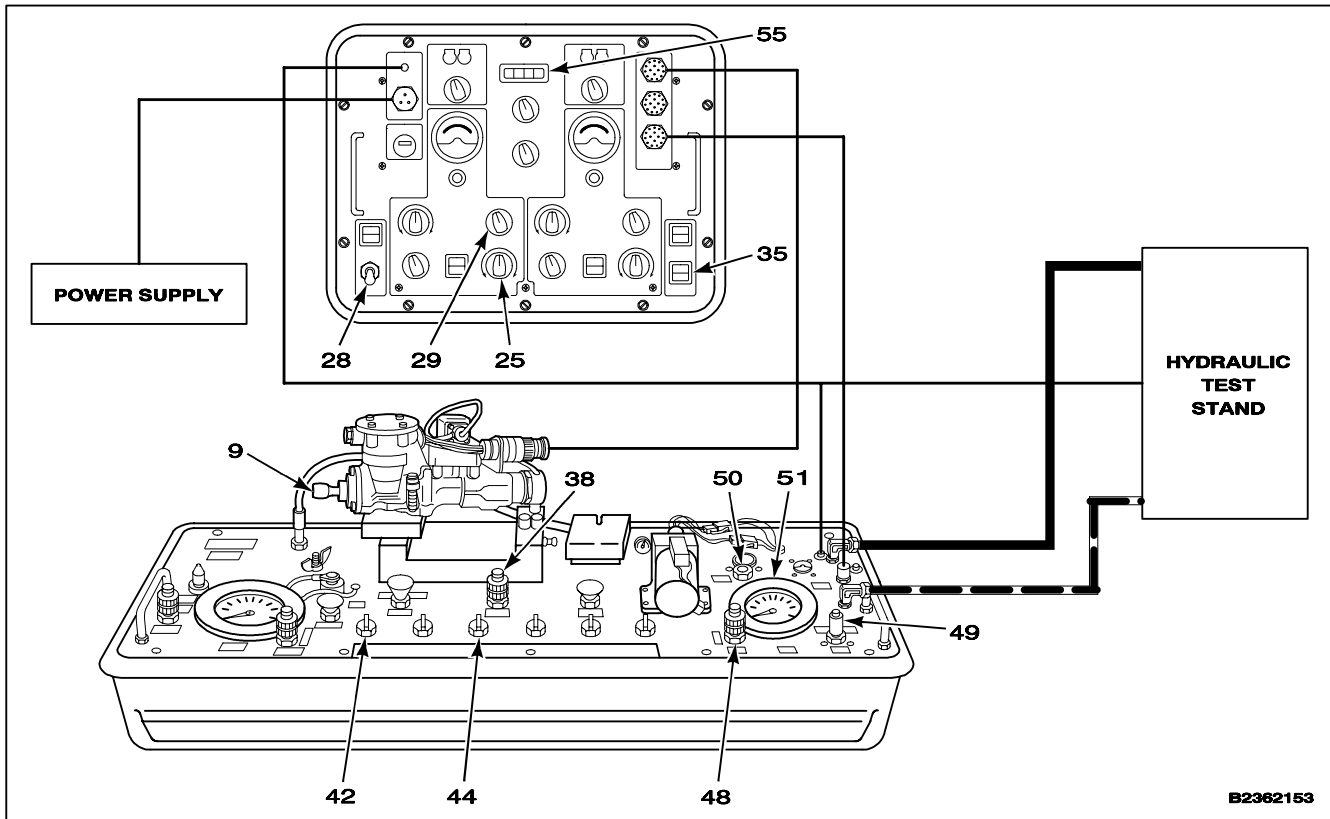

B2362153

TEST 21
STABILITY TEST

- 389. Perform steps 1 thru 40.
- 390. POWER switch (28) to ON.
- 391. Set LINK TEST switch (29) to SELF FDBK.
- 392. Set FUNCTION SELECT switch (21) to BALANCE.
- 393. Install dial indicator (3) on post (57). Position anvil of indicator against piston (9).
- 394. Set electrical and hydraulic unit controls as follows:
 - a. Check RETURN SHUTOFF valve (38) is OPEN.
 - b. SOLENOID valve (50) to OPENED.
 - c. SOLENOID SHUTOFF switch (35) to OPEN.
 - d. RETURN SYS 1 valve (42) to RETURN.
 - e. SAS PRESS SYS 1 valve (44) to PRESS.
 - f. Slowly turn HIGH PRESS REGULATOR valve (49) toward INCREASE until HIGH PRESS gauge (51) indicates **1500 psi**.

- g. Slowly turn HIGH PRESS SHUTOFF valve (48) to OPEN.
 - 395. Set FUNCTION SELECT switch (21) to HARD OVER RETRACT then BALANCE.
 - 396. Adjust dial indicator (3) for a reading of **1 inch**. Set FUNCTION SELECT switch (21) to HARD OVER RETRACT then BALANCE.
- NOTE**
- An overshoot of **0.002 to 0.005 inch** is allowed on indicator, but piston must stop within **1 second**.
- 397. Check dial indicator (3) for piston (9) movement. There shall be no movement and indicator shall indicate **1 inch**.
 - 398. Set FUNCTION SELECT switch (21) to HARD OVER EXTEND then BALANCE.
 - 399. Adjust dial indicator (3) for a reading of **1 inch**. Set the FUNCTION SELECT switch (21) to HARD OVER EXTEND then BALANCE.
 - 400. Check dial indicator (3) for piston (9) movement. There shall be no movement and indicator shall indicate **1 inch**.

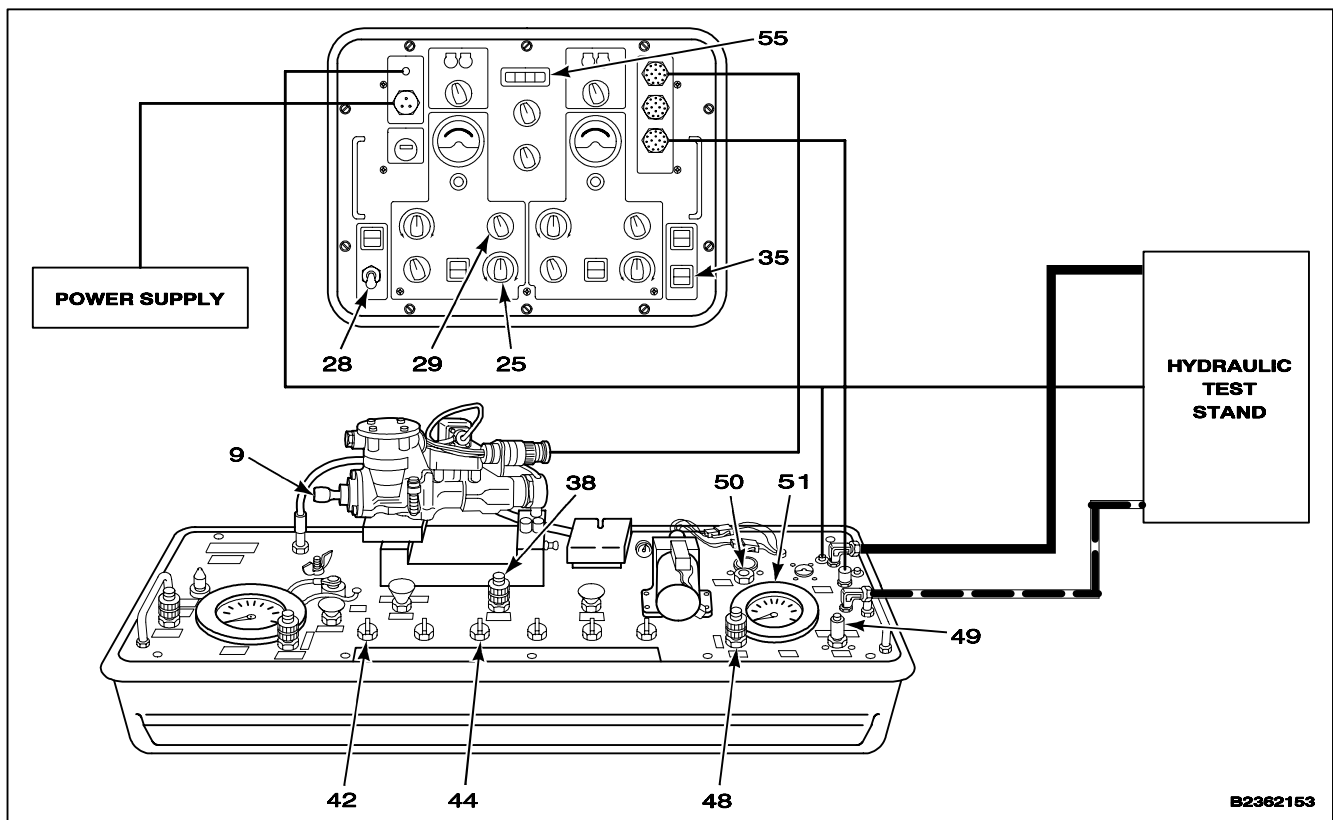

B2362153

- 401. Set FUNCTION SELECT switch (21) to CLSD LOOP.
- 402. Set electrical and hydraulic unit controls as follows:
 - a. HIGH PRESS REGULATOR valve (49) to DECREASE.
 - b. HIGH PRESS SHUTOFF valve (48) to CLOSE.
 - c. SOLENOID SHUTOFF switch (35) to CLOSED.
 - d. SOLENOID valve (50) to CLOSED.
 - e. SAS PRESS SYS 1 valve (44) to VENT.
 - f. Push and hold HIGH PRESS RELIEF valve (53) and LOW PRESS RELIEF valve (54) for **15 seconds**.
 - g. SAS PRESS SYS 1 valve (44) to OFF.
 - h. RETURN SYS 1 valve (42) to OFF.
- 403. Set LINK TEST switch (29) to VALVE.
- 404. Remove dial indicator (3). Stow in cover.
- 405. If no further testing is required, perform normal shutdown (TM 55-4920-428-13).

END OF STABILITY TEST

FOLLOW-ON MAINTENANCE:

None

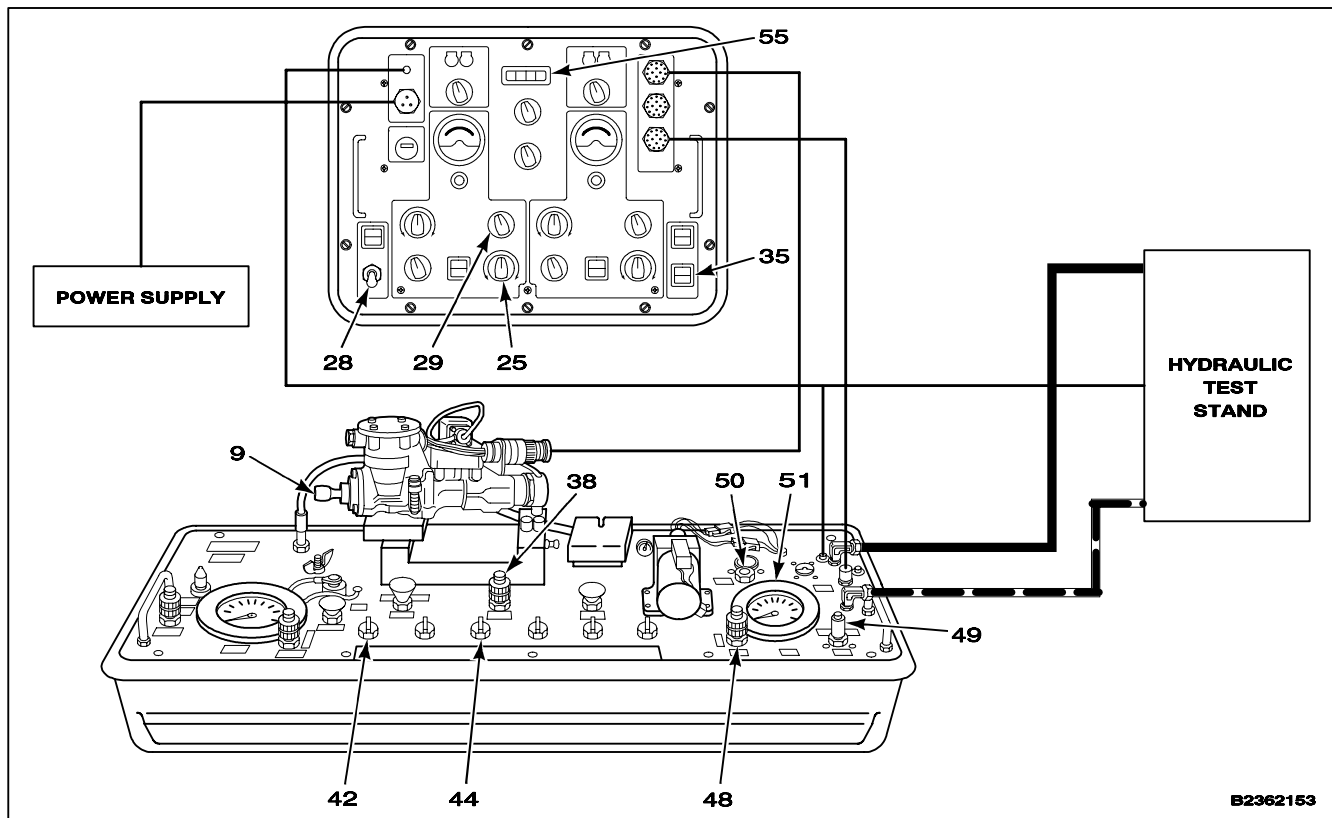

B2362153

END OF TASK

7-99 ADJUST PITCH, ROLL, OR YAW INTEGRATED LOWER CONTROL ACTUATOR (ILCA) CROSS FEEDBACK TRANSDUCER ON AIRCRAFT

7-99

INITIAL SETUP

Applicable Configurations:

All

Tools:

- AFCS Line Test Set 145G0009-1
- Aircraft Mechanic's Tool Kit, NSN 5180-00-323-4692
- Dial Indicating Scale, 0 to 10 Pounds

Materials:

Lockwire (E230)

Personnel Required:

- Avionics Mechanic
- Inspector

References:

- TM 55-1520-240-23P
- TM 55-4920-429-13
- Task 7-87
- Task 7-88

Equipment Condition:

- AFCS Line Test Set 145G0009-1 Prepared For Use With No. 1 AFCS Computer (TM 55-4920-429-13) Pitch, Roll Or Yaw Cross Transducers Tested For Null (Task 11-280, Test 1, 3, or 5)
- Flight Controls Closet Acoustic Blanket Removed (Task 2-107)
- Flight Control Closet Panel Removed (Task 2-2)
- Integrated Lower Control Pitch, Roll or Yaw Actuator (ILCA) Removed (Task 7-84)

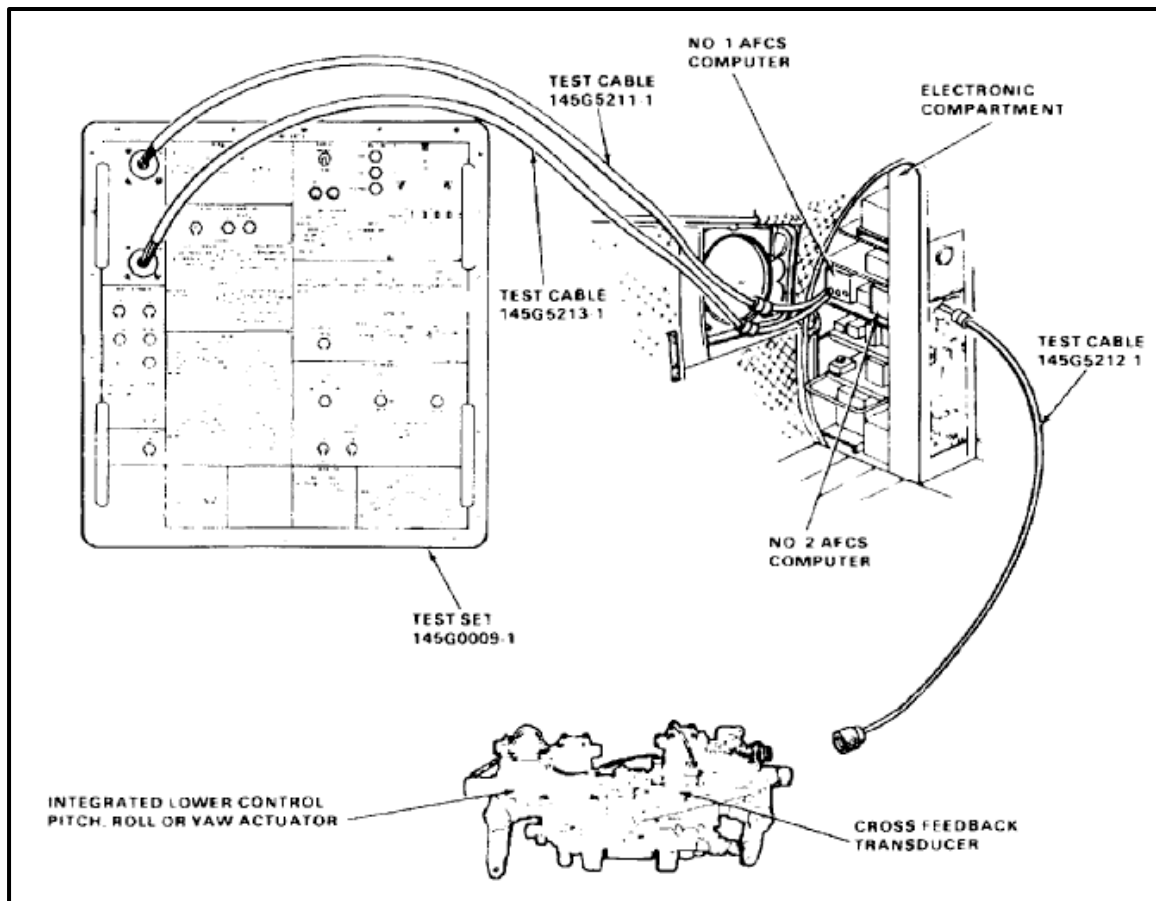

**7-99 ADJUST PITCH, ROLL, OR YAW INTEGRATED LOWER CONTROL ACTUATOR (ILCA)
CROSS FEEDBACK TRANSDUCER ON AIRCRAFT (Continued)**

1. Connect test cable 145GS212-1 (1) between helicopter wire harnesses (2 or 3) and ILCA (4) as follows:

ILCA CONTROL	HARNESS CONNECTOR	ILCA EXTENSIBLE LINK
Pitch	031J13	No. 1
Pitch	031J14	No. 2
Roll	031J15	No. 1
Roll	031J16	No. 2
Yaw	031J17	No. 1
Yaw	031J18	No. 2

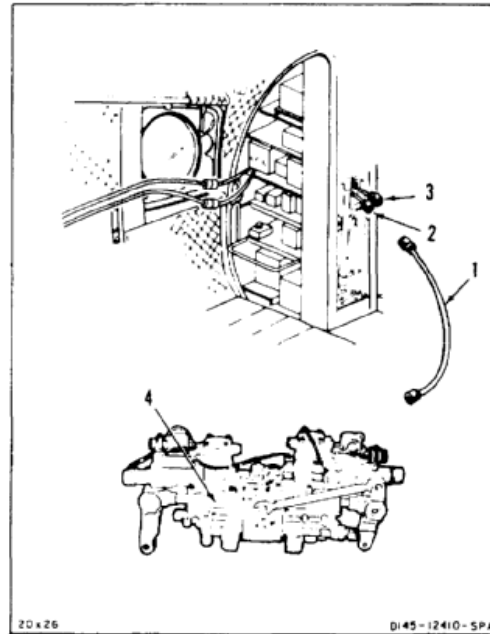

**7-99 ADJUST PITCH, ROLL, OR YAW INTEGRATED LOWER CONTROL ACTUATOR (ILCA)
CROSS FEEDBACK TRANSDUCER ON AIRCRAFT (Continued)**

7-99

2. Set AFCS SYSTEM SEL switch (5) to 1.
3. Set AFCS Line Test Set switches as follows:
 - a. Two MASTER POWER switches (6) to ON.
 - b. METER SOURCE switch (7) to ILCA DRIVE.
 - c. MONITOR SELECT switch (8) to PITCH, ROLL, or YAW.
4. Remove lockwire from nut (9) and bearing (10) from transducer (11).
5. Loosen nut (9) until rod (12) can be turned with fingers. Turn nut counterclockwise.
6. Turn rod (12) until display (13) indicates **0**.
7. Torque nut (9) to **17 inch-pounds**. Use wrench and scale.
8. Record reading 'X' of display (13). Check display reads **-25 to +25**. If not, repeat steps 6 and 7.

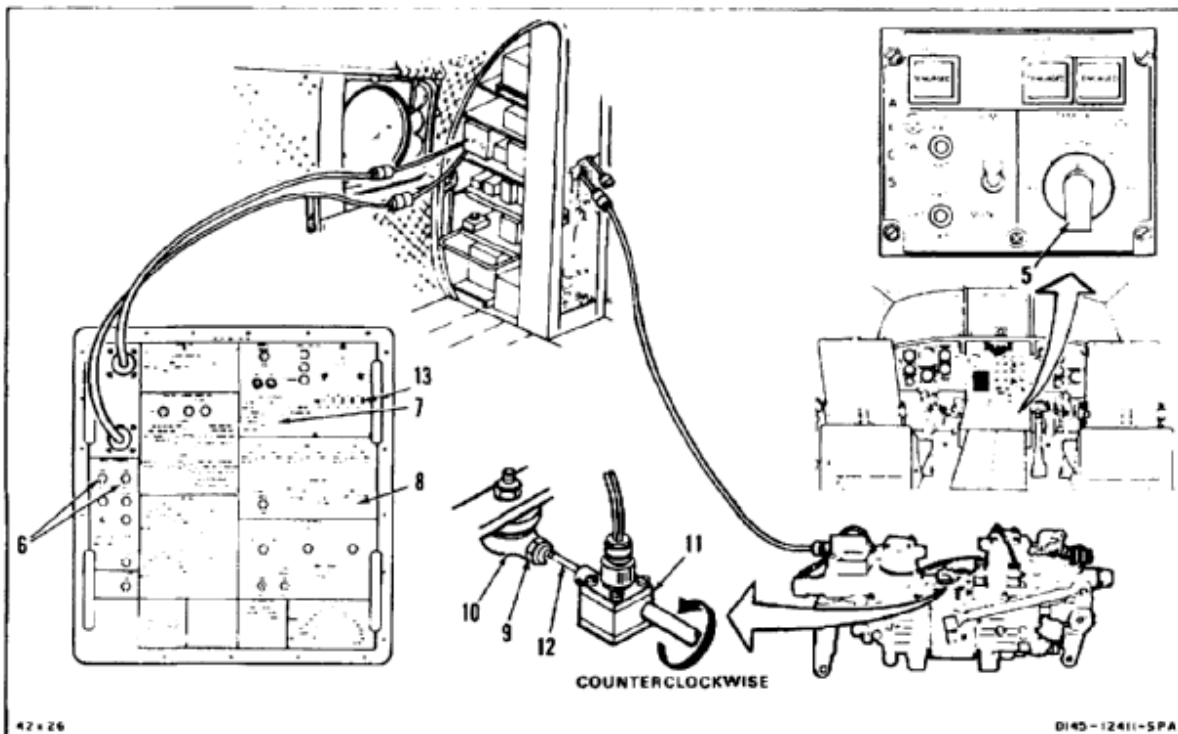
INSPECT

42x26

D143-12411-5 PA

**7-99 ADJUST PITCH, ROLL, OR YAW INTEGRATED LOWER CONTROL ACTUATOR (ILCA)
CROSS FEEDBACK TRANSDUCER ON AIRCRAFT (Continued)**

7-99

9. Prepare AFCS line test set (14) for use with No. 2 AFCS computer (TM 55-4920-429-13).
10. Repeat step 1 for No. 2 extensible link (16).
11. Set AFCS SYSTEM SEL switch (5) to 2.
12. Set MONITOR SELECT FDBK switch (9) to SUM 2. Record reading 'Y' of display (13). Reading 'Y' shall be within **25** of reading 'X' from step 8. Perform check as follows:

-X +Y shall not be more than **0**
 +X +Y shall not be more than **+50**
 -X -Y shall not be more than **-50**
 +X -Y shall not be more than **0**

If transducer is not adjustable, perform Tasks 7-87 and 7-88, then repeat steps 1 thru 12.

13. Lockwire nut (9) to bearing (10). Use lockwire (E230).

INSPECT

14. If no further testing is required, set two MASTER POWER switches (6) to OFF.
15. Disconnect cable (1) from harness (2 or 3).
16. Disconnect and secure AFCS line test set (15) (TM 55-4920-429-13).

FOLLOW-ON MAINTENANCE:

Install pitch, roll, or yaw ILCA (Task 7-102).

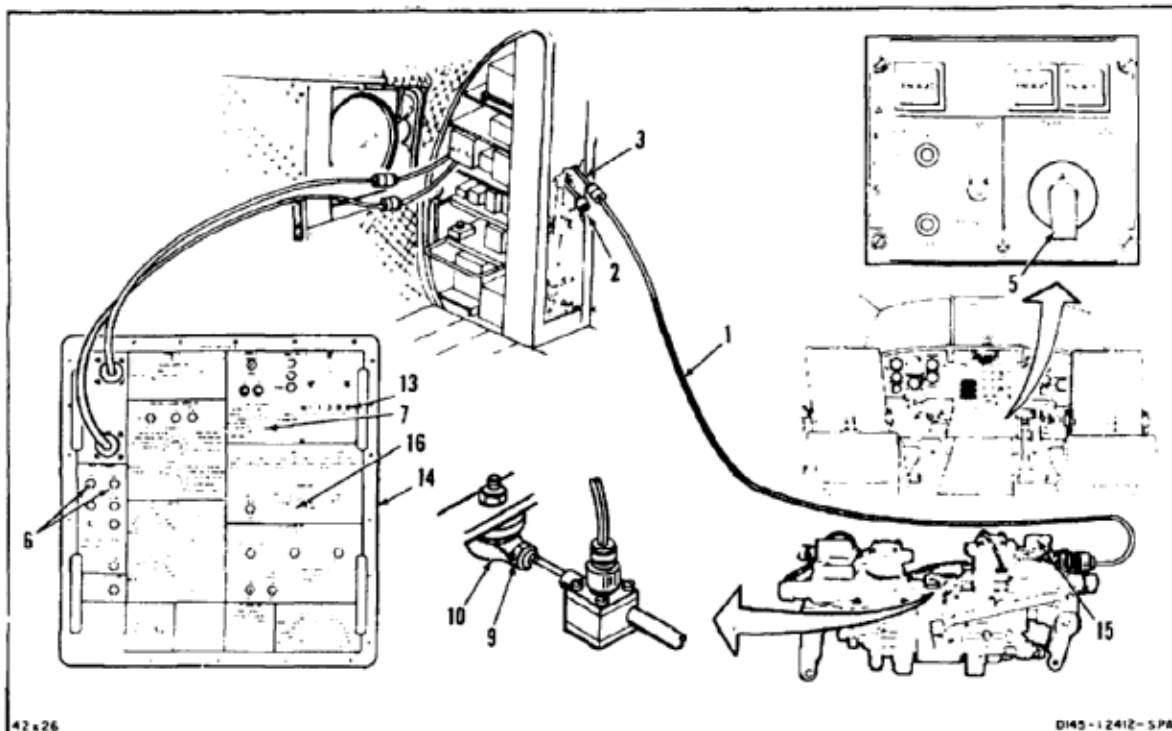

END OF TASK

7-476

7-100 ADJUST INTEGRATED LOWER CONTROL ACTUATOR (ILCA) CROSS FEEDBACK TRANSDUCER (AVIM)

INITIAL SETUP

Applicable Configurations:

All

Tools:

- Integrated Lower Controls Actuator Bench Test Set 145GS278-1
- Power Source 115 Volt, 60 Hz AC
- Hydraulic Repairer's Tool Kit, NSN 5180-00-323-4891
- Safety Ground Cable
- Dial Indicating Scale, 0 to 10 Pounds

Materials:

Lockwire (E230)

Parts:

None

Personnel Required:

- Aircraft Pneudraulics Repairer
- Avionic Navigation and Flight Control Equipment Repairer
- Inspector

Equipment Condition:

- Off Helicopter Task
- Integrated Lower Control Actuator (ILCA) Bench Test Set Unit Prepared for Use (TM 55-4920-428-13)
- Integrated Lower Control Actuator (ILCA) Installed on Test Set (Task 7-98, Test 4)

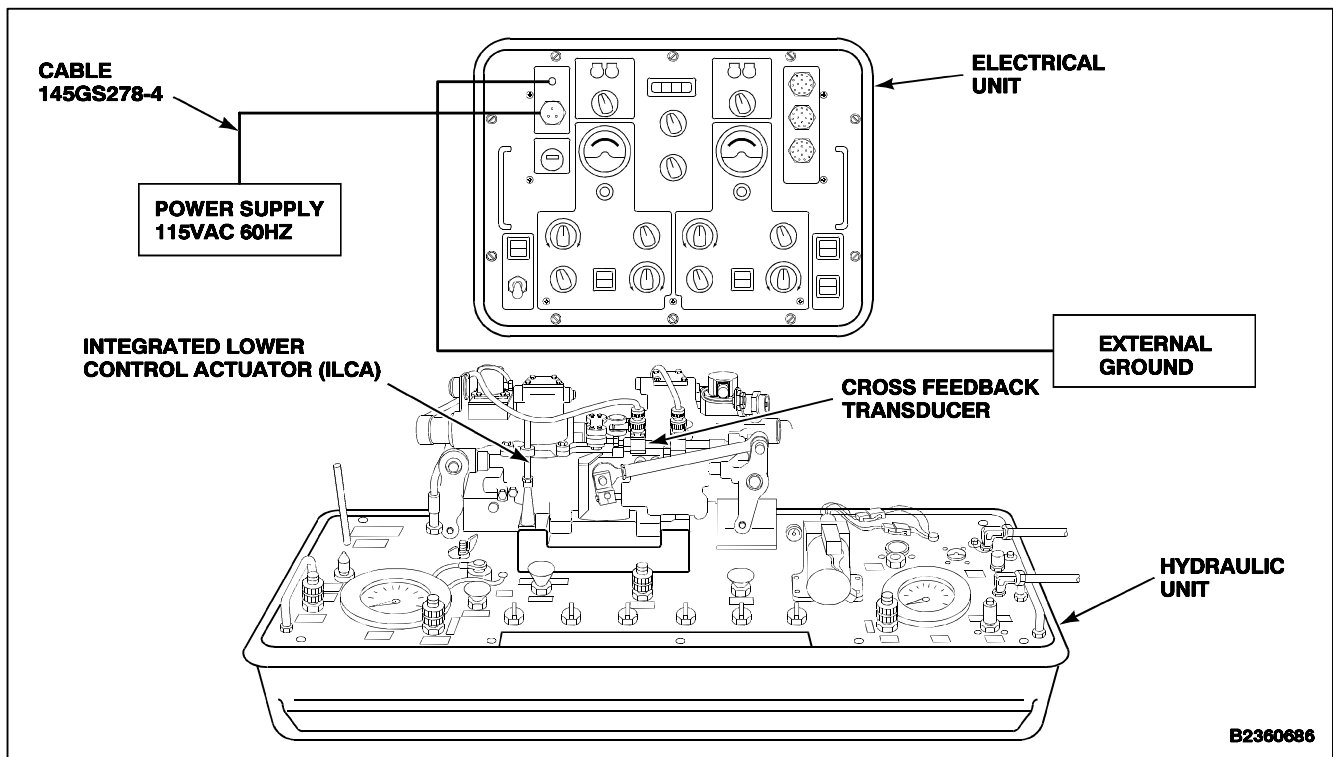

1. Connect No. 1 cable 145GS278-5 (1) between SAS 1 receptacle (2) and No. 1 extensible link receptacle (3).
2. Connect No. 2 cable 145GS278-6 (4) between SAS 2 receptacle (5) and No. 2 extensible link receptacle (6).
3. Set electrical unit controls as follows:
 - a. Power switch (7) to ON.
 - b. Both FUNCTION SELECT switches (8 and 9) to CLSD LOOP.
 - c. Both FEEDBACK SELECT switches (10 and 11) to CROSS.
 - d. Both VALVE CONTROLS (12 and 13) to NULL.
 - e. Both SQ WAVE controls (14 and 15) to MINIMUM.
 - f. Both LINK TEST switches (16 and 17) to CROSS FDBK.
 - g. Both EXTERNAL METER SELECT switches (18 and 19) to SELF FDBK.
 - h. BITE switch (20) to **-20V**.

- i. SYSTEM SELECT switch (21) to SAS 1.
- j. SOLENOID SHUTOFF switch (22) to CLOSE.
- k. CYCLE MOTOR switch (23) to OFF.
- l. LAMP TEST switch (24) to Released (out).



Do not bend rod. Rod is easily broken.

4. Remove lockwire from nut (25) and bearing (26) of transducer (27) on actuator (28).
5. Loosen nut (25) until rod (29) can be turned with fingers. Turn nut counterclockwise.
6. Deleted.
7. Turn rod (29) until DVM (31) indicates NULL.
8. Torque nut (25) to **17 inch-pounds**. Use wrench and indicating scale.
9. DVM (31) reading shall not exceed **0.018 volts**. Record reading. If more than **0.018 volts**, repeat steps 5 thru 8.

INSPECT

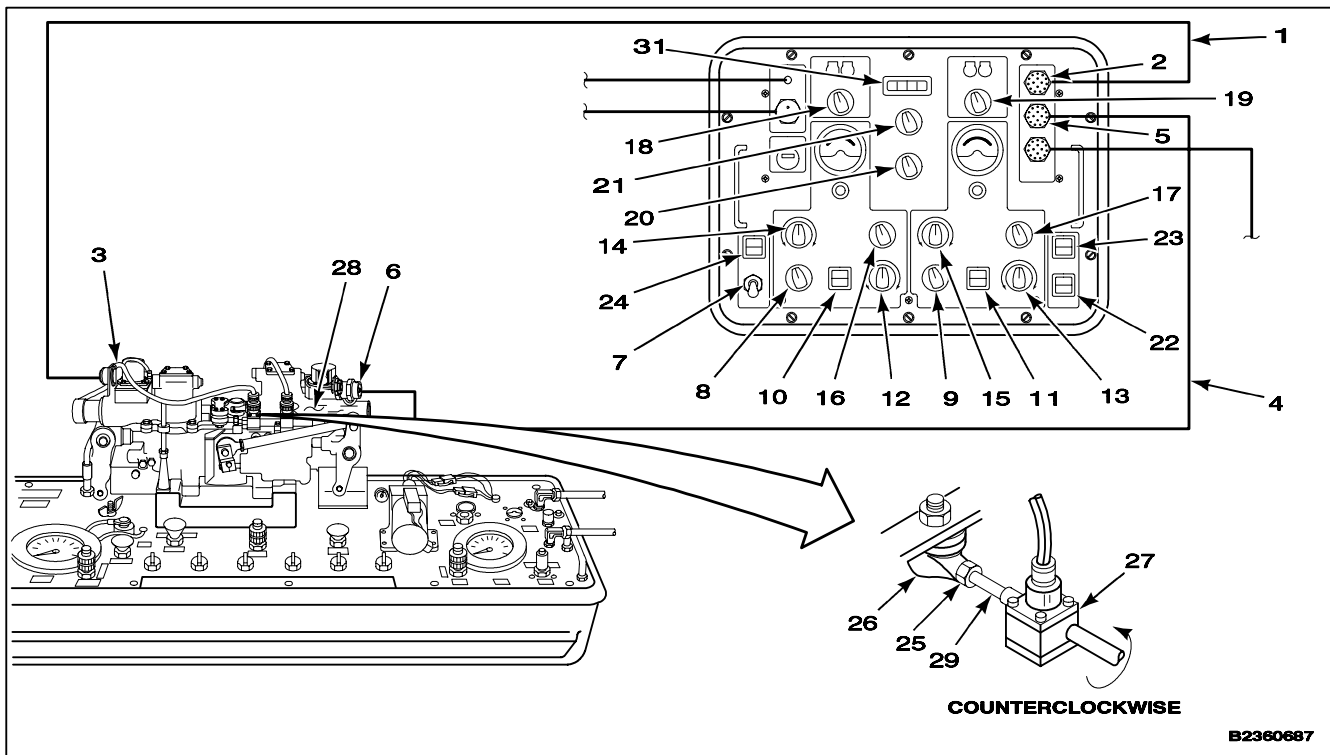

**7-100 ADJUST INTEGRATED LOWER CONTROL ACTUATOR (ILCA) CROSS FEEDBACK
TRANSDUCER (AVIM) (Continued)**

7-100

10. Set SYSTEM SELECT switch (21) to SAS 2.
11. Check DVM (31) indication. Reading shall not exceed **0.043**.

NOTE

If DVM (31) reading is greater than **0.043**, replace transducer, repeat Task 7-100.

12. Lockwire nut (25) to bearing (26). Use lockwire (E230).

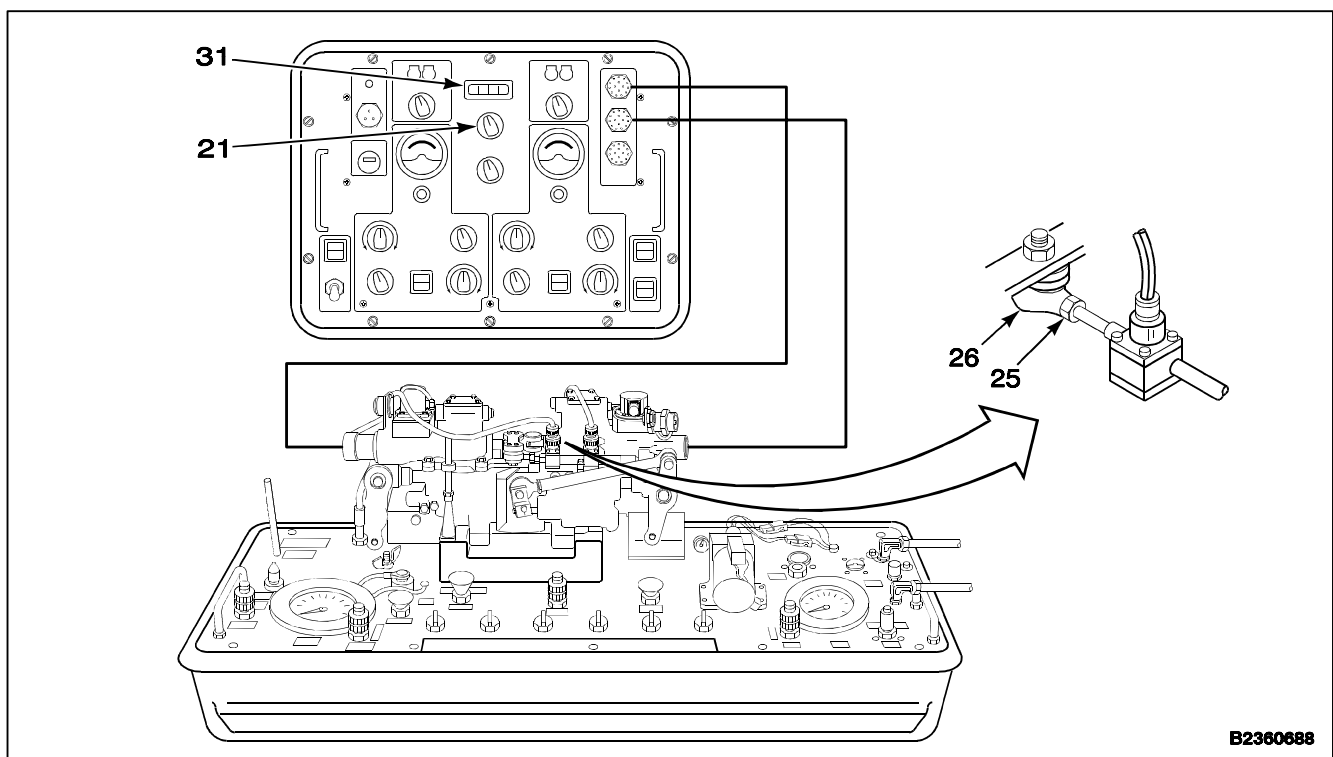
INSPECT

B2360688

- 13. If no further testing is required, set POWER switch (7) to OFF.
- 14. Disconnect both ends of cable (1). Stow cable in unit cover.
- 15. Disconnect both ends of cable (4). Stow cable in unit cover.
- 16. Loosen four screws (36).
- 17. Remove actuator (28) from manifold (34).
- 18. Install dial indicator (35) on manifold (34) using thumbscrew (33).
- 19. Disconnect and secure ILCA bench test set 145GS278-1 (TM 55-4920-428-13).

FOLLOW-ON MAINTENANCE:

None

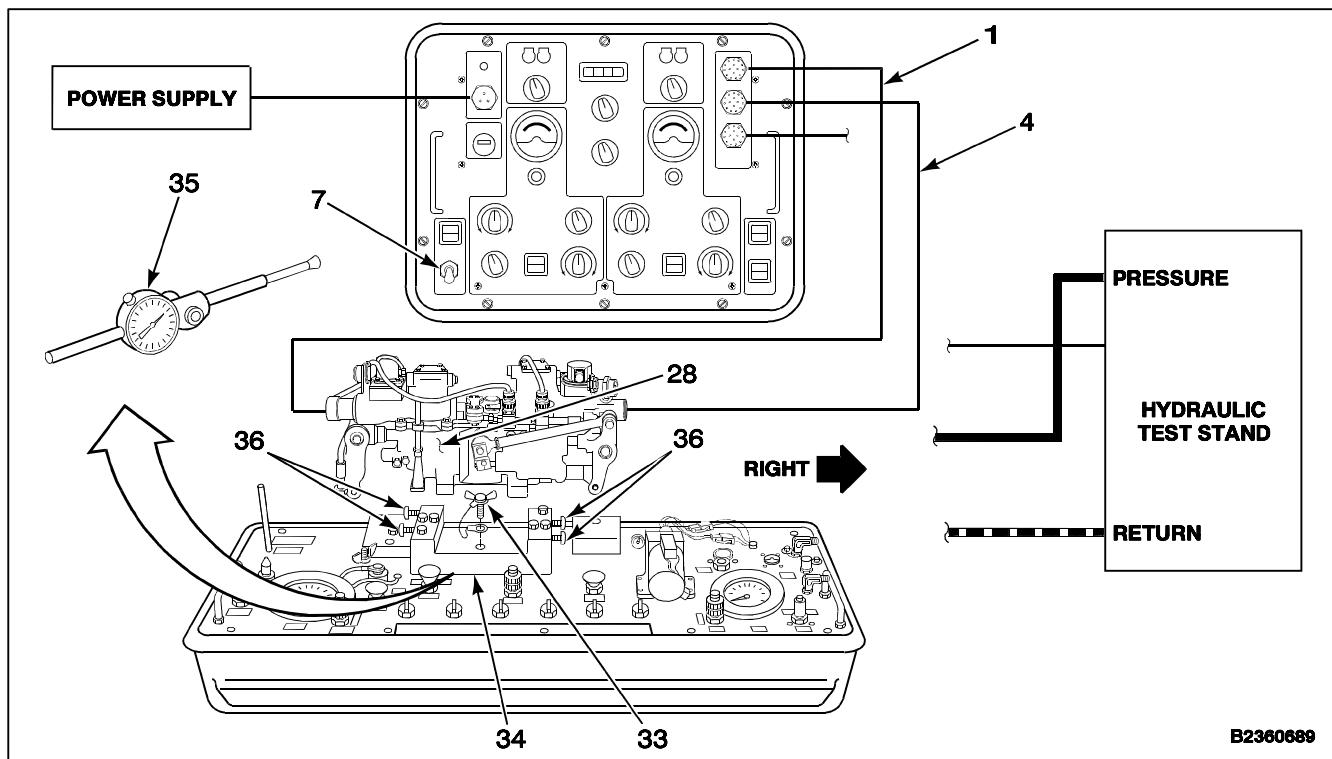

B2360689

END OF TASK

INITIAL SETUP

Applicable Configurations:

All

Tools:

- Integrated Lower Controls Actuator Bench Test Set 145GS278-1 (T53)
- Electrical Instrument Shop Set, NSN 4920-00-165-1453
- Power Source 115 Volt, 60 Hz AC
- Hydraulic Repairer's Tool Kit, NSN 5180-00-323-4891
- Safety Ground Cable
- Test Adapter 145GS278-20
- Torque Wrench, 30-150 Inch-Pounds
- Contact Removal/Insertion Tool, M83723/20
- Contact Removal/Insertion Tool, M81969/1403
- Crowfoot, 1-1/4 Inch

Materials:

- Lockwire (E227)
- Lockwire (E230)

Parts:

- Strap (MS3367-1-9)

Personnel Required:

- Aircraft Pneudraulics Repairer
- Avionic Navigation and Flight Control Equipment Repairer
- Inspector

References:

- TM 55-1500-323-24
- TM 55-1520-240-23P
- TM 55-4920-428-13
- Task 7-88.1

Equipment Condition:

- Off Helicopter Task
- Integrated Lower Control Actuator Bench Test Set (ILCA) Prepared for Use (TM 55-4920-428-13)
- Integrated Lower Control Actuator Installed on Test Set (Task 7-98, Test 1 or 2) or Extensible Link Installed on Test Set (Task 7-97, Test 1 Preliminary Procedure)

NOTE

Adjustment can be performed on No. 1 or No. 2 extensible link installed on actuator or with extensible link as separate part. No. 1 extensible link on actuator shown.

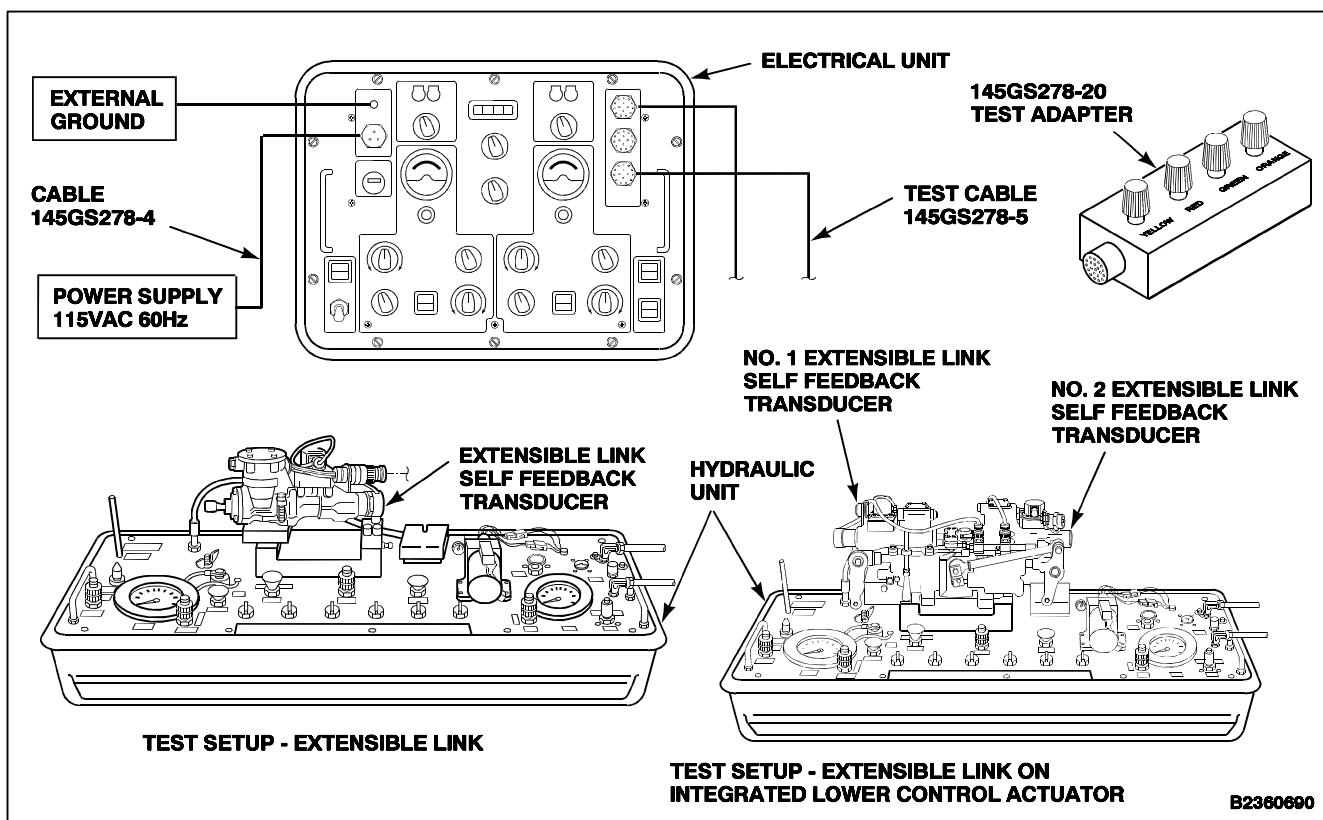

B2360690

NOTE

For a No. 2 extensible link installed on an actuator, use SAS 2 test set controls.

1. Set electrical unit controls as follows:
 - a. Power switch (1) to ON.
 - b. Both FUNCTION SELECT switches (2 and 3) to CLSD LOOP.
 - c. Both FEEDBACK SELECT switches (4 and 5) to SELF.
 - d. Both VALVE CONTROLS (6 and 7) to NULL.
 - e. Both SQ WAVE controls (8 and 9) to MINIMUM.
 - f. Both LINK TEST switches (10 and 11) to SELF FDBK.
 - g. Both EXTERNAL METER SELECT switches (12 and 13) to SELF FDBK.
 - h. BITE switch (14) to -20V.
 - i. SYSTEM SELECT switch (15) to SAS 1.
 - j. SOLENOID SHUTOFF switch (16) to CLOSE.
 - k. CYCLE MOTOR switch (17) to OFF.
 - l. LAMP TEST switch (18) to released (out).
2. Remove lockwire from retainer (19) and lockring (20) from transducer (21).
3. Cut strap (22). Remove strap.
4. Turn retainer (19) counterclockwise until lockring (20) can be parted from lockring (23). Keep lockrings apart.

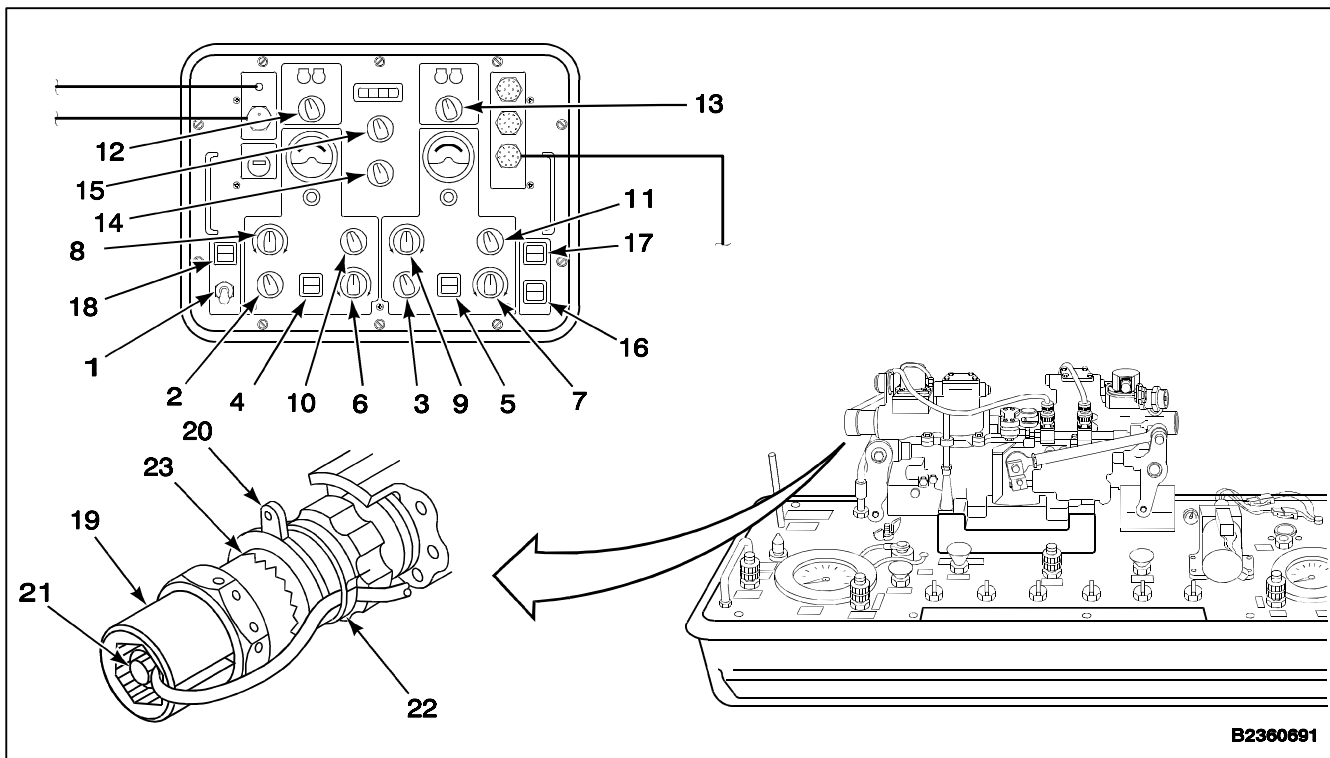

NOTE

Perform steps 5 thru 9 only if a large adjustment of the SELF FEEDBACK transducer is required.

5. Set test power switch (1) to OFF.

NOTE

Deleted.

6. Tag and disconnect four wires (24, 25, 26, and 27) from pins 1, 2, 3, and 4 of receptacle (28) of extensible link (29).
7. Connect four wires (24, 25, 26, and 27) to terminals (30, 31, 32, and 33) of test adapter (34). Match wire colors with colors marked on adapter.

8. Connect cable 145GS278-5 (35) between receptacle (36) of adapter (34) and SAS 1 receptacle (37) of electrical unit.
9. Set POWER switch (1) to ON.
10. Turn transducer (21) until DVM (39) indicates NULL.
11. Hold transducer (21) and move lockrings (20 and 23) together. Release transducer.
12. Hand tighten retainer (19).
13. Check DVM (39). Reading shall not exceed **0.018 volts**. If greater than **0.018 volts**, repeat steps 4 thru 13.
14. Torque retainer (19) to **85 inch-pounds**. Use **1-1/4 inch** crowfoot.

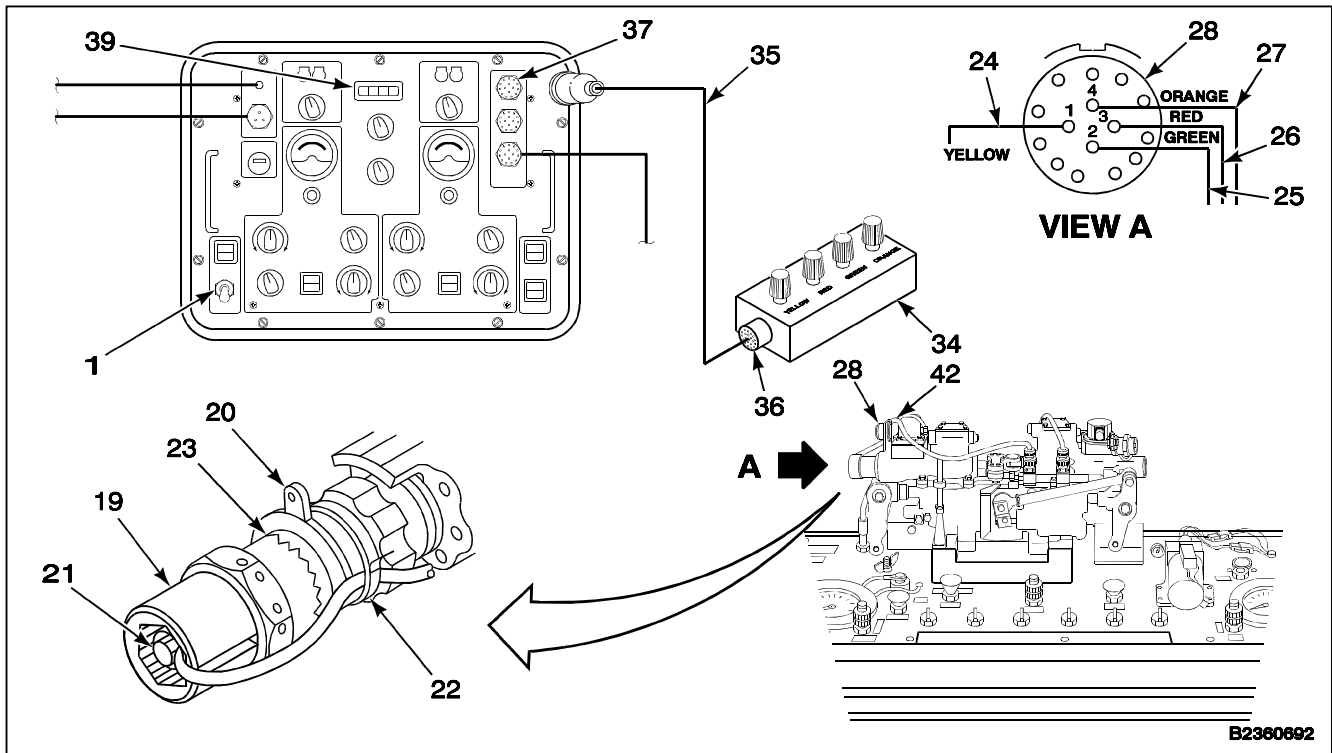

- 15. Lockwire retainer (19) to lockring (20). Use lockwire (E230).
- 16. Set power switch (1) to OFF.

NOTE

Deleted.

- 17. Disconnect four wires (24, 25, 26, and 27) from test adapter (34).
- 18. If not previously installed, install receptacle (28) on wires (24, 25, 26, and 27) in accordance with TM 55-1500-323-24.
- 19. Install backshell (40) in receptacle (28).
- 20. Install strap (41) on backshell (40).
- 21. Position receptacle (28) in bracket (42). Install locknut (43) on receptacle.
- 22. Position wire (44) on bracket (42). Install screw (45) in wire and bracket. Torque screw to **30 inch-pounds**.
- 23. Lockwire two screws (45 and 46) of bracket (42). Use lockwire (E230).

- 24. Lockwire locknut (43) to bracket (42). Use lockwire (E227).
- 25. Position cable (47) of transducer (21) in bottom of slot (48). Install strap (22) on cable and support (49). Use strap MS3367-1-9.
- 26. Connect 145GS278-5 (35) to receptacle (28).
- 27. Set power switch (1) to ON.
- 28. Check DVM (39). Reading shall not exceed **0.018 volts**. If greater than **0.018 volts**, repeat steps 4 thru 16.

INSPECT

- 29. Disconnect cable (35) from receptacles (28 and 37) and stow.
- 30. Repeat steps 2 thru 27 for No. 2 extensible link.
- 31. If no further testing is required, shut down ILCA bench test set 145GS278-1 (TM 55-4920-428-13).

FOLLOW-ON MAINTENANCE:

Perform Test 19 in Task 7-98.

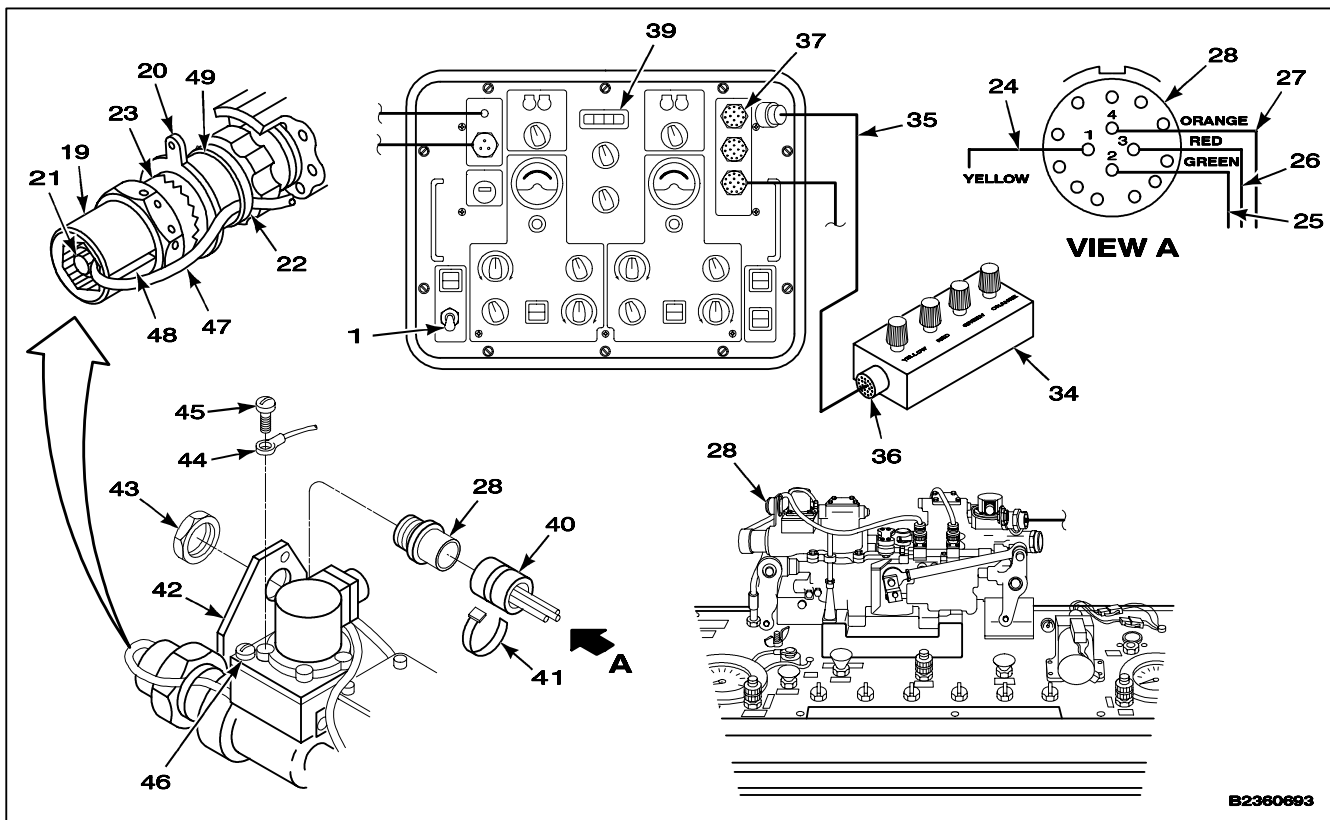

B2360693

END OF TASK

INITIAL SETUP

Applicable Configurations:

All

Tools:

Aircraft Mechanic's Tool Kit, NSN 5180-00-323-4692
Torque Wrench, 30 to 150 Inch-Pounds

Materials:

Lockwire (E231)

Parts:

Cotter Pins

Personnel Required:

Medium Helicopter Repairer (2)
Inspector

References:

TM 55-1520-240-23P

General Safety Instructions:

WARNING

Prior to installation, inspect the ILCA data plate to ensure suffix "V" is added behind the S/N. If it is not, then comply with MWO 1-1520-240-50-66 by installing new screw, new nut and vibro etching the "V" behind the S/N.

WARNING

Integrated lower control actuators are not directly interchangeable from one axis to another axis without changing authority covers. Authority covers and resultant piston strokes of links are different. Direct interchanging of ILCAs can result in dangerous flight characteristics.

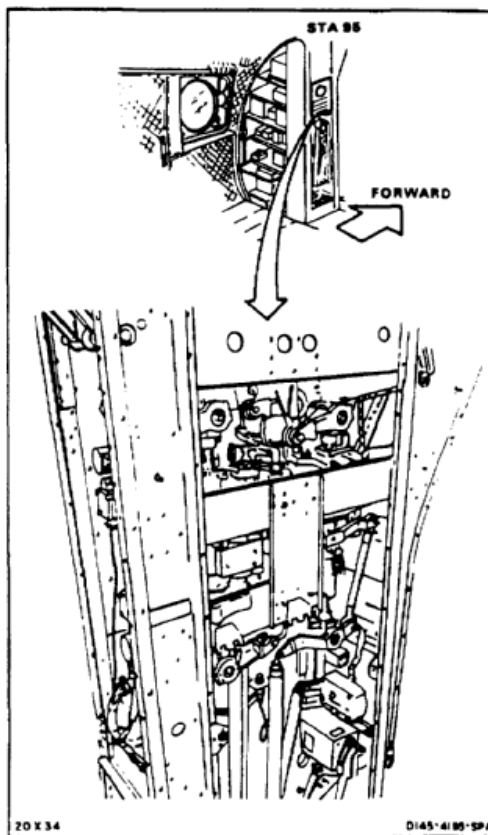

TABLE A

NOTE

ILCAs 145H7300-16 and -20 are interchangeable with 145H7300 series in any axis when authority cover is removed from faulty unit and installed on replacement unit. Refer to Task 7-86.

ILCA SPARE PART NO.	AUTHORITY COVER PART NO.	NEW ILCA PART NO.	AXIS
145H7300-16	145H7357-1	145H7300-13	PITCH
145H7300-16	145H7357-2	145H7300-14	ROLL
145H7300-16	145H7357-3	145H7300-15	YAW
145H7300-20	145H7357-1	145H7300-17	PITCH
145H7300-20	145H7357-2	145H7300-18	ROLL
145H7300-20	145H7357-3	145H7300-19	YAW

NOTE

Procedure is same to install any integrated lower control actuator (ILCA) except where noted in text. Installation of pitch actuator is shown here.

There are no electrical connectors on thrust actuator.

1. Have helper support actuator (1). Position actuator on manifold (2). Align tube (3) with port (4).

NOTE

There are four bolts installed in actuator. Two on top and two on bottom. Top bolts are longer.

2. Install two bolts (5) and washers (6).
3. Install two bolts (7) and washers (8).

4. Torque bolts (5 and 7) to **60 inch-pounds**.
5. Lockwire bolts (5 and 7) in pairs. Use lockwire (E231).
6. Position rod end (9) in lever (10). Install bolt (11), two washers (12), and nut (13).
7. Position rod (14) in lever (15). On pitch actuator (1), install bolt (16), two washers (17), bushing (18), and nut (19). On roll, yaw, and thrust actuator (1), install bolt, three washers, nut, and cotter pin.
8. Torque nuts (13 and 19) to **30 to 60 inch-pounds**.
9. Install cotter pin (20) in nuts (13 and 19).
10. Check bolts (11 and 16). Bolts shall not rotate with torque less than **10 inch-pounds**. There shall be no axial looseness. If bolts rotate or are loose, add washer under nut (13 and 19) and repeat steps 8 and 9.

INSPECT

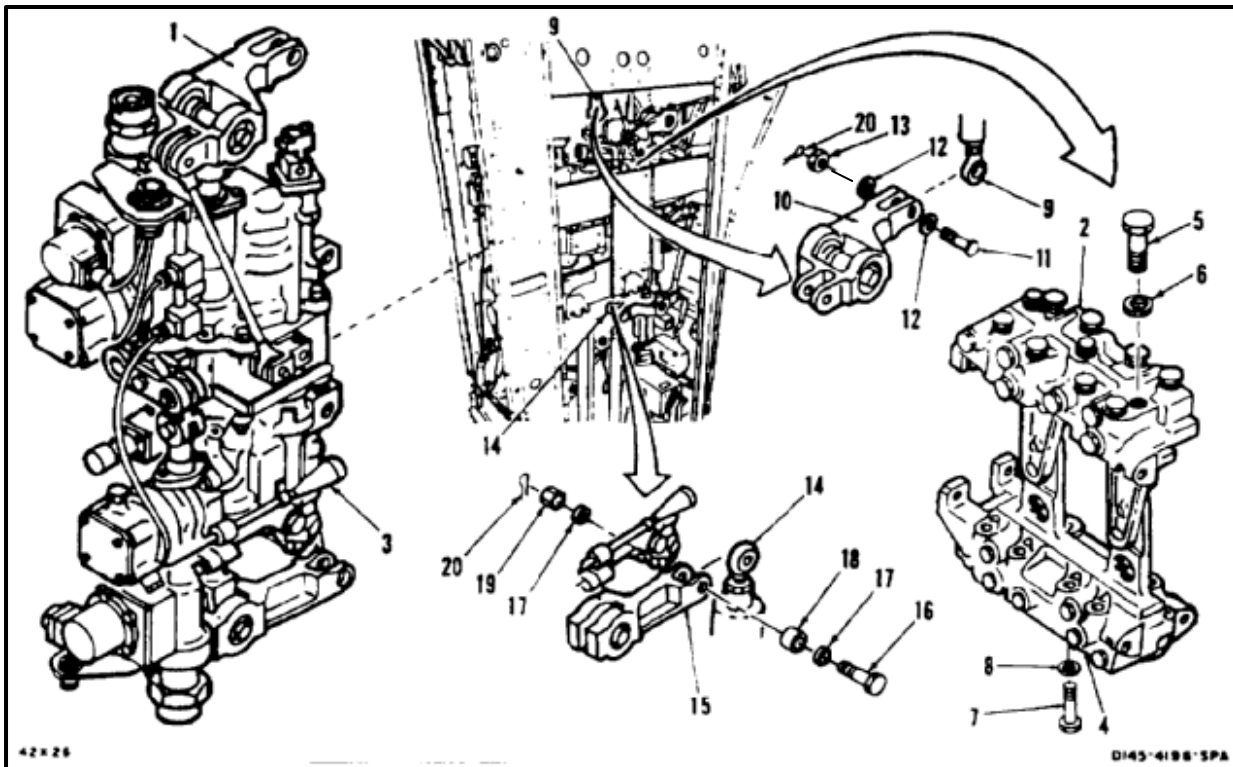

11. Connect two cable connectors (21) to actuator (1).

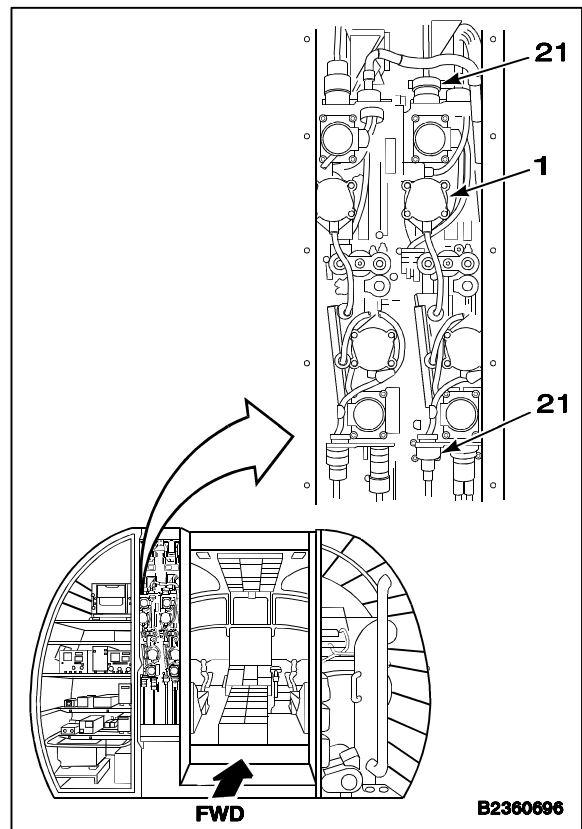

FOLLOW-ON MAINTENANCE:

- Bleed flight control hydraulic system (Task 7-16).
- Install controls closet panel (Task 2-2).
- Install controls closet acoustic blanket (Task 2-108).
- Remove safety blocks (Task 11-29).
- AFCS operational check (TM 55-1520-240-T).

END OF TASK

INITIAL SETUP

Applicable Configurations:

All

Tools:

Aircraft Mechanic's Tool Kit, NSN 5180-00-323-4692
Container, 2 Quart

Materials:

Cloths (E135)
Paper Tags (E264)
Gloves (E186)
Goggles (E473)

Personnel Required:

CH-47 Helicopter Repairer (2)

Equipment Condition:

Battery Disconnected (Task 1-39)
Electrical Power Off
Controls Closet Acoustic Blanket Removed (Task 2-107)
Controls Closet Panel Removed (Task 2-2)
Integrated Lower Control Actuators Removed (Task 7-84)

General Safety Instructions:**WARNING**

Hydraulic fluid (E199) is toxic. It can irritate skin and cause burns. Avoid inhaling. Use only with adequate ventilation. Avoid contact with skin, eyes, or clothing. In case of contact, immediately flush skin or eyes with water for at least **15 minutes**. Get medical attention for eyes.

WARNING

Hydraulic fluid ejected under pressure can cause injury to personnel. Hydraulic fluid sprayed into the air is a fire hazard.

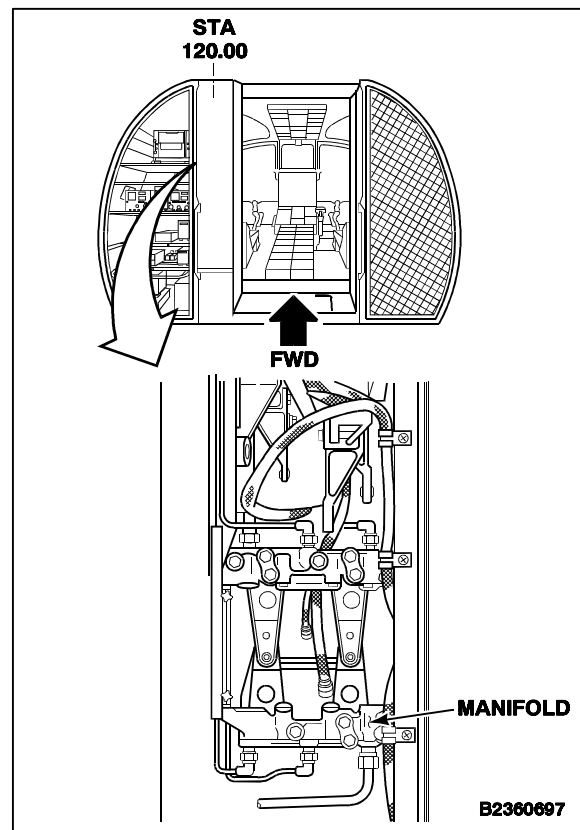

NOTE

There are six tubes. Three connected to top and three connected to bottom of manifold.

1. Tag and disconnect six tubes (1) from manifold (2). Use container and cloths (E135) for spilled fluid. Use gloves (E186).
2. Have helper support manifold (2). Remove seven bolts (3), eleven washers (4), and four nuts (5).
3. Remove manifold (2) from mounts (6).

FOLLOW-ON MAINTENANCE:

None

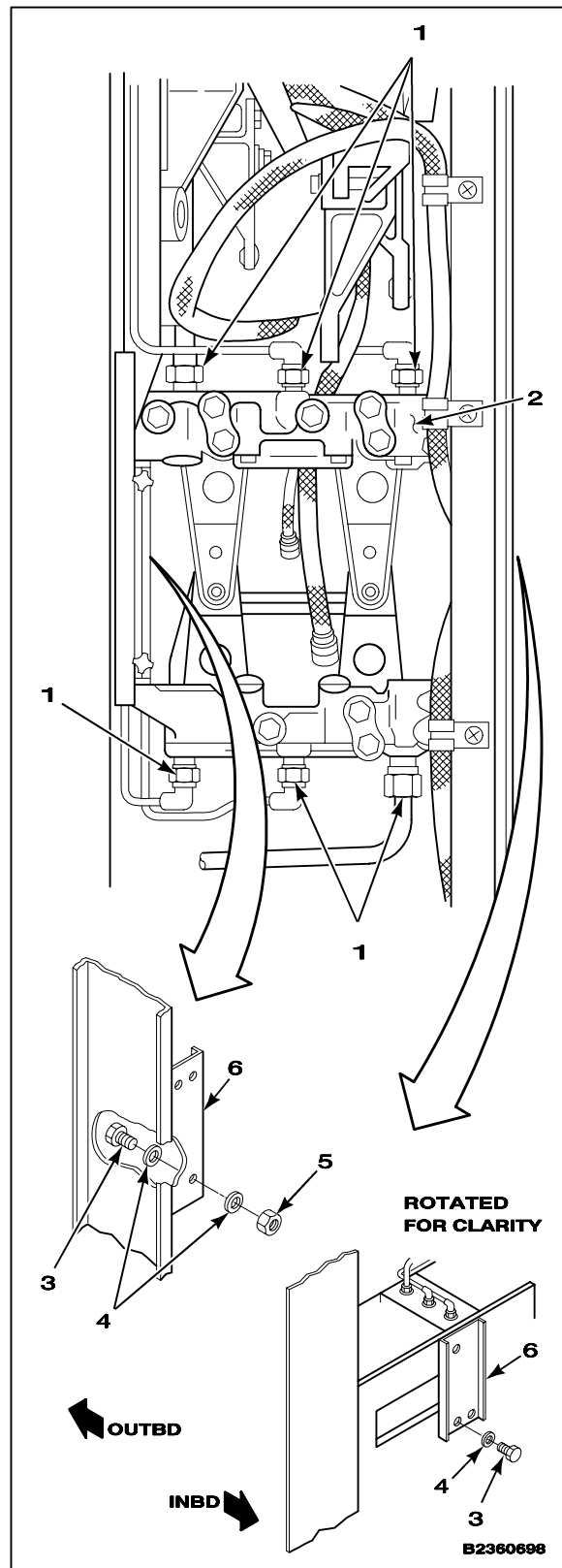

END OF TASK

INITIAL SETUP

Applicable Configurations:

All

Tools:

Aircraft Mechanic's Tool Kit, NSN 5180-00-323-4692
Container, 2 Quart

Materials:

Cloth, Cleaning (E120)
Gloves (E184.1)
Goggles (E473)

Personnel Required:

CH-47 Helicopter Repairer

Equipment Condition:

Battery Disconnected (Task 1-39)
Electrical Power Off
Controls Closet Acoustic Blanket Removed (Task 2-107)
Controls Closet Panel Removed (Task 2-2)
Integrated Lower Control Actuators (ILCA) Removed (Task 7-84)
Drain No. 1 and No. 2 Flight Control Hydraulic System Reservoir (Task 1-60.1)
Power Drain Flight Control Hydraulic System Reservoir (Task 1-61.1)

General Safety Instructions:**WARNING**

Hydraulic fluid (E199) is toxic. It can irritate skin and cause burns. Avoid inhaling. Use only with adequate ventilation. Avoid contact with skin, eyes, or clothing. In case of contact, immediately flush skin or eyes with water for at least **15 minutes**. Get medical attention for eyes.

WARNING

Hydraulic fluid ejected under pressure can cause injury to personnel. Hydraulic fluid sprayed into the air is a fire hazard.

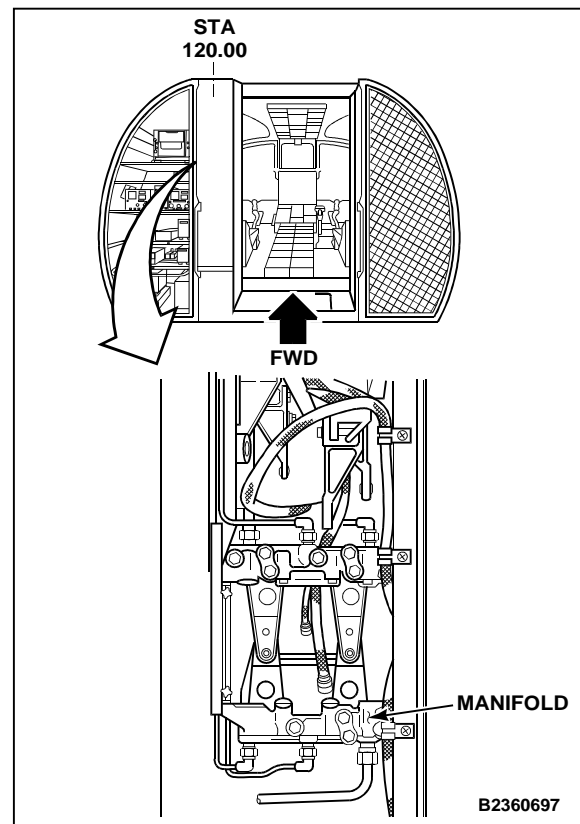

7-103.1 REMOVE LOWER CONTROLS ACTUATOR STRUCTURAL MANIFOLD CHECK VALVE ASSEMBLY (Continued)

7-103.1

NOTE

There are 22 check valve assemblies in the ILCA structural manifold. The procedure is the same to remove any one of them.

1. Put on gloves (E184.1). Use container and cloths (E120) for spilled hydraulic fluid.
2. Remove check valve (1) from structural manifold (2). Use a **1/4 inch** socket with an extension to engage the hex at the end of the check valve.
3. Cover the check valve cavity (3) in structural manifold (2) to prevent contamination of the flight control hydraulic system.
4. Remove and discard packings (4 and 5) from check valve (1).
5. Repeat steps 1 thru 4 as necessary to remove any of the other check valves.

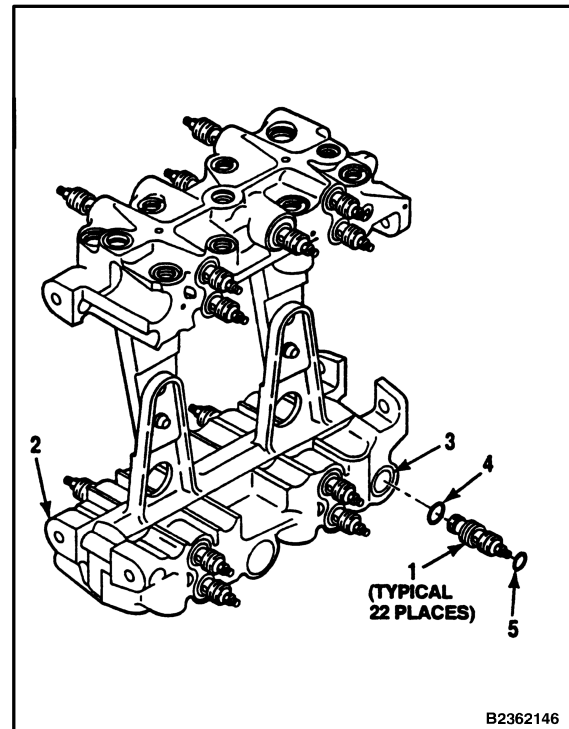
**FOLLOW-ON MAINTENANCE:**

None

END OF TASK

INITIAL SETUP

Applicable Configurations:

All

Tools:

Aircraft Mechanic's Tool Kit, NSN 5180-00-323-4692

Materials:

Hydraulic Fluid (E199)

Gloves (E184.1)

Personnel Required:CH-47 Helicopter Repairer
Inspector**References:**

TM 55-1520-240-23P

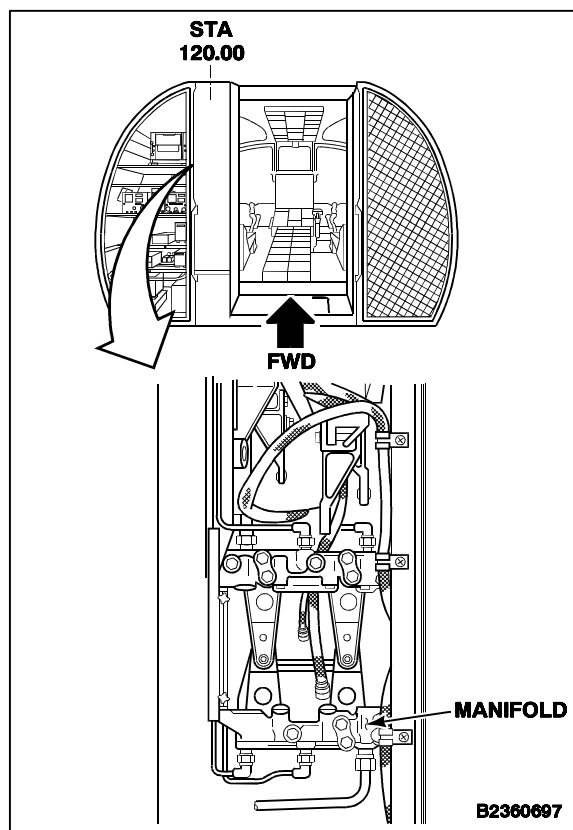

7-103.2 INSTALL LOWER CONTROLS ACTUATOR STRUCTURAL MANIFOLD CHECK VALVE ASSEMBLY (Continued)

7-103.2

1. Prior to the installation of a new check valve, do a visual inspection of it for damage.
2. Perform the following plunger pin stroking and flow checks prior to installation:
 - a. Hold the check valve in your hand and press the plunger pin on the top of it squarely against a hard, flat surface.
 - b. The plunger pin must depress until its end is flush with the body of the check valve.
 - c. Release the pin. It must freely and immediately extend on its own.

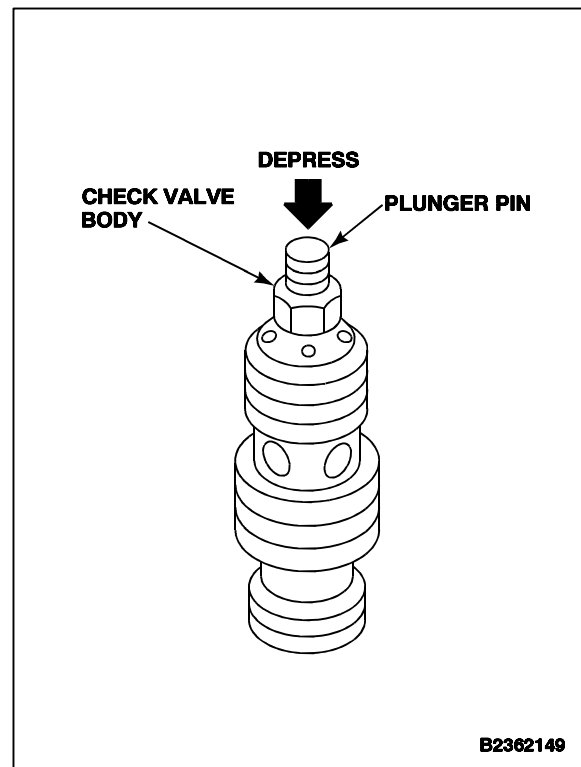

- d. Depress the plunger pin. Blow air through the six small holes at the plunger end. Blow air through the four large holes on the side of the valve. The air must pass freely.
- e. Release the plunger pin. Air must not pass through either set of holes.
- f. If the valve fails any of the tests in steps a thru e, replace it.

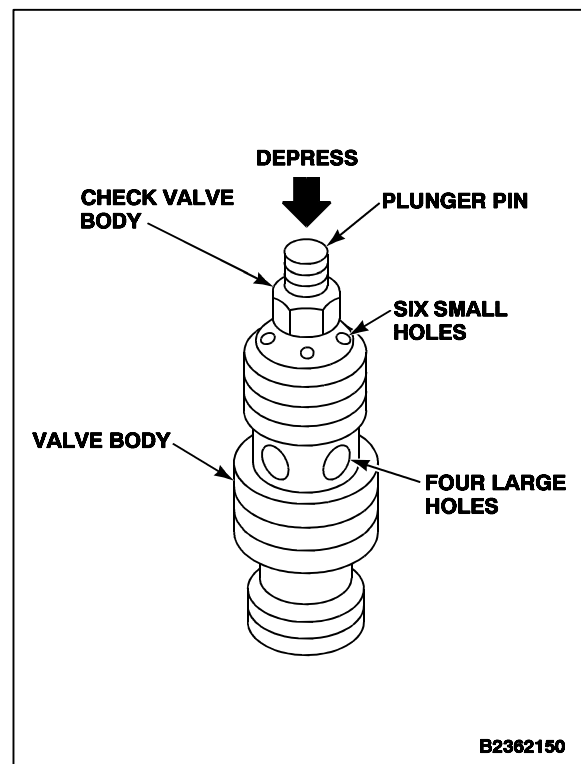

WARNING

Hydraulic fluid (E199) is toxic. It can irritate skin and cause burns. Avoid inhaling. Use only with adequate ventilation. Avoid contact with skin, eyes, or clothing. In case of contact, immediately flush skin or eyes with water for at least **15 minutes**. Get medical attention for eyes.

3. Put on gloves (E184.1). Clean the outside of check valve (1). Use a cloth or wet with hydraulic fluid (E199).
4. Lubricate new packing (2 and 3) with hydraulic fluid (E199). Install packings in the check valve (1) grooves.
5. Thread check valve (1) into manifold cavity (4) until it bottoms. Once the packings engage the cavity, it may be necessary to use **1/4 inch** socket to aid in installation.
6. Check valve (1) is only to be installed until it is snug against the bottom of cavity (4). Do not torque.

INSPECT

FOLLOW-ON MAINTENANCE:

- Install integrated lower control actuator (ILCA) (Task 7-102).
- Bleed flight control hydraulic system (Task 7-16).
- Perform operational check (TM 55-1520-240-T).
- Install controls closet panel (Task 2-2).
- Install controls acoustic blanket (Task 2-108).

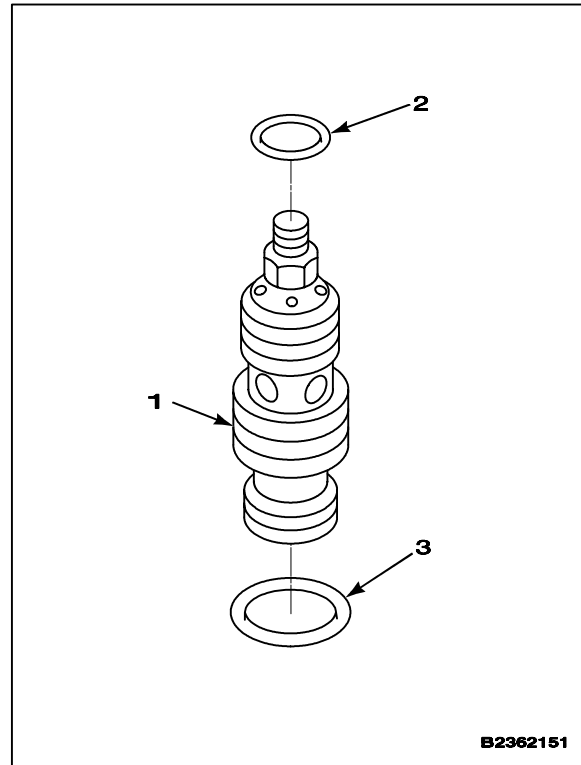

B2362151

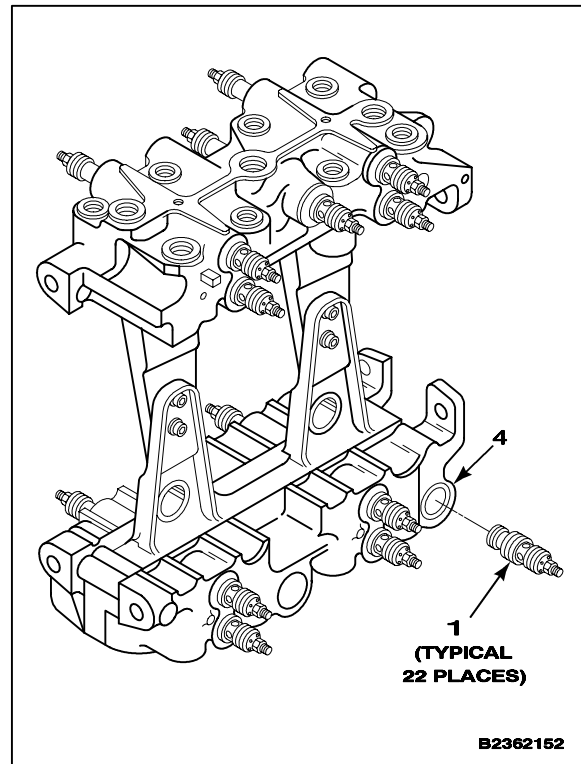

B2362152

END OF TASK

INITIAL SETUP

Applicable Configurations:

All

Tools:

Aircraft Mechanic's Tool Kit, NSN 5180-00-323-4692
Torque Wrench, 100-750 Inch-Pounds

Materials:

None

Personnel Required:

CH-47 Helicopter Repairer (2)
Inspector

References:

TM 55-1520-240-23P

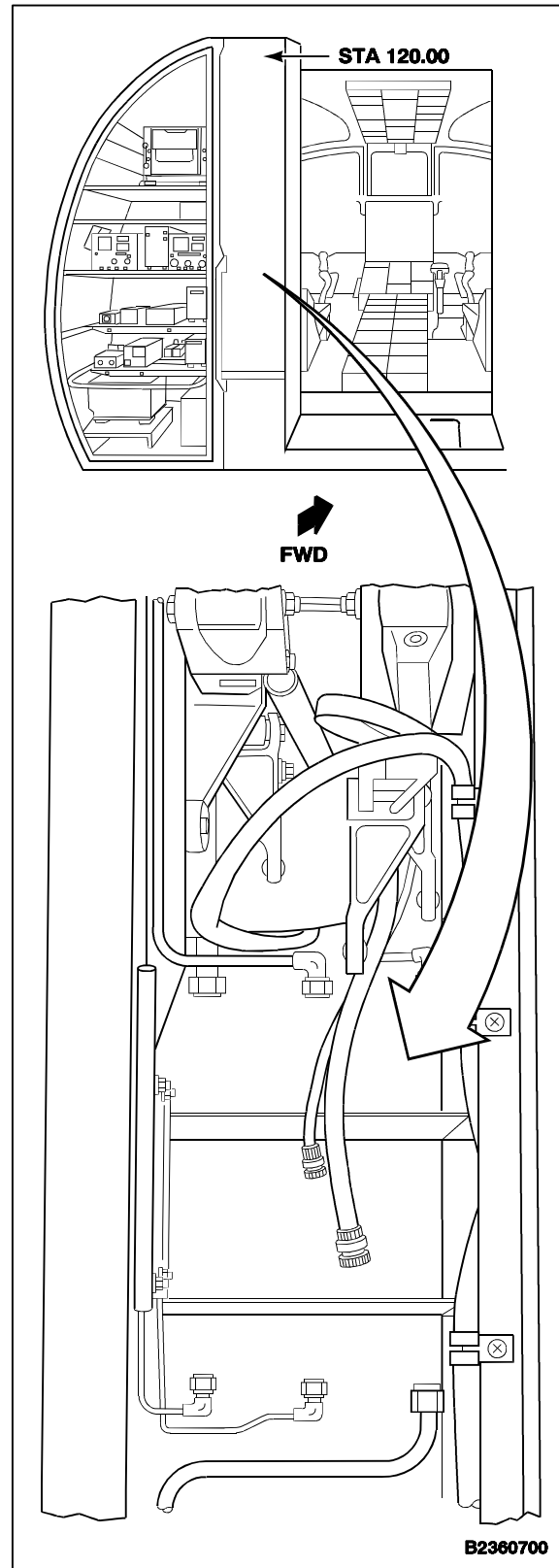

7-104 INSTALL LOWER CONTROLS ACTUATOR STRUCTURAL MANIFOLD (Continued)

1. Position manifold (1), hole (2) inboard and up, between mounts (3). Have helper support manifold. Install three bolts (4) and washers (5).
2. Install four bolts (6), eight washers (7), and four nuts (8).

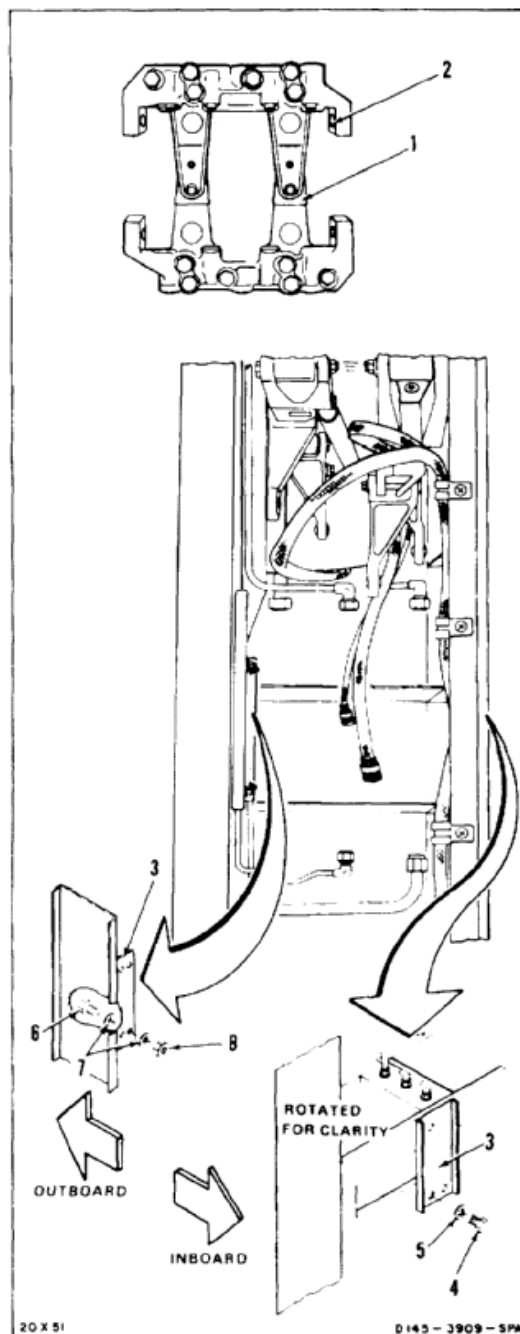

NOTE

There are six tubes. Three connected to top and three connected to bottom of manifold.

3. Connect tube (9) to fitting (10).
4. Connect tube (11) to fitting (12).
5. Connect tube (13) to fitting (14).
6. Connect tube (15) to fitting (16).
7. Connect tube (17) to fitting (18).
8. Connect tube (19) to fitting (20).
9. Torque tubes (9, 11, 13 and 16) to **140 inch-pounds**.
10. Torque tubes (17 and 19) to **170 inch-pounds**.

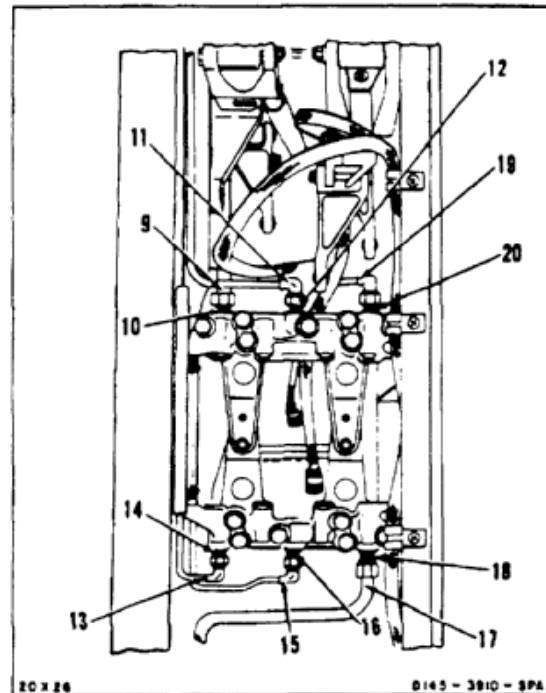
INSPECT**FOLLOW-ON MAINTENANCE:**

- Install integrated lower control actuator (ILCA) (Task 7-102).
- Bleed flight control hydraulic system (Task 7-16).
- Perform operational check (TM 55-1520-240-T).
- Install controls closet panel (Task 2-2).
- Install controls closet acoustic blanket (Task 2-108).

END OF TASK

7-492

INITIAL SETUP

Applicable Configurations:

All

Tools:

Hydraulic Repairer's Tool Kit, NSN 5180-00-323-4891
Hydraulic Test Stand

Materials:

None

Personnel Required:

Medium Helicopter Repairer
Aircraft Pneudraulics Repairer
Inspector

References:

Task 7-84
Task 7-102

Equipment Condition:

Control Closet Acoustic Blanket Removed (Task 2-107)
Controls Closet Panel Removed (Task 2-2)
Electrical Power On
Hydraulic Power On
Battery Connected (Task 1-39)

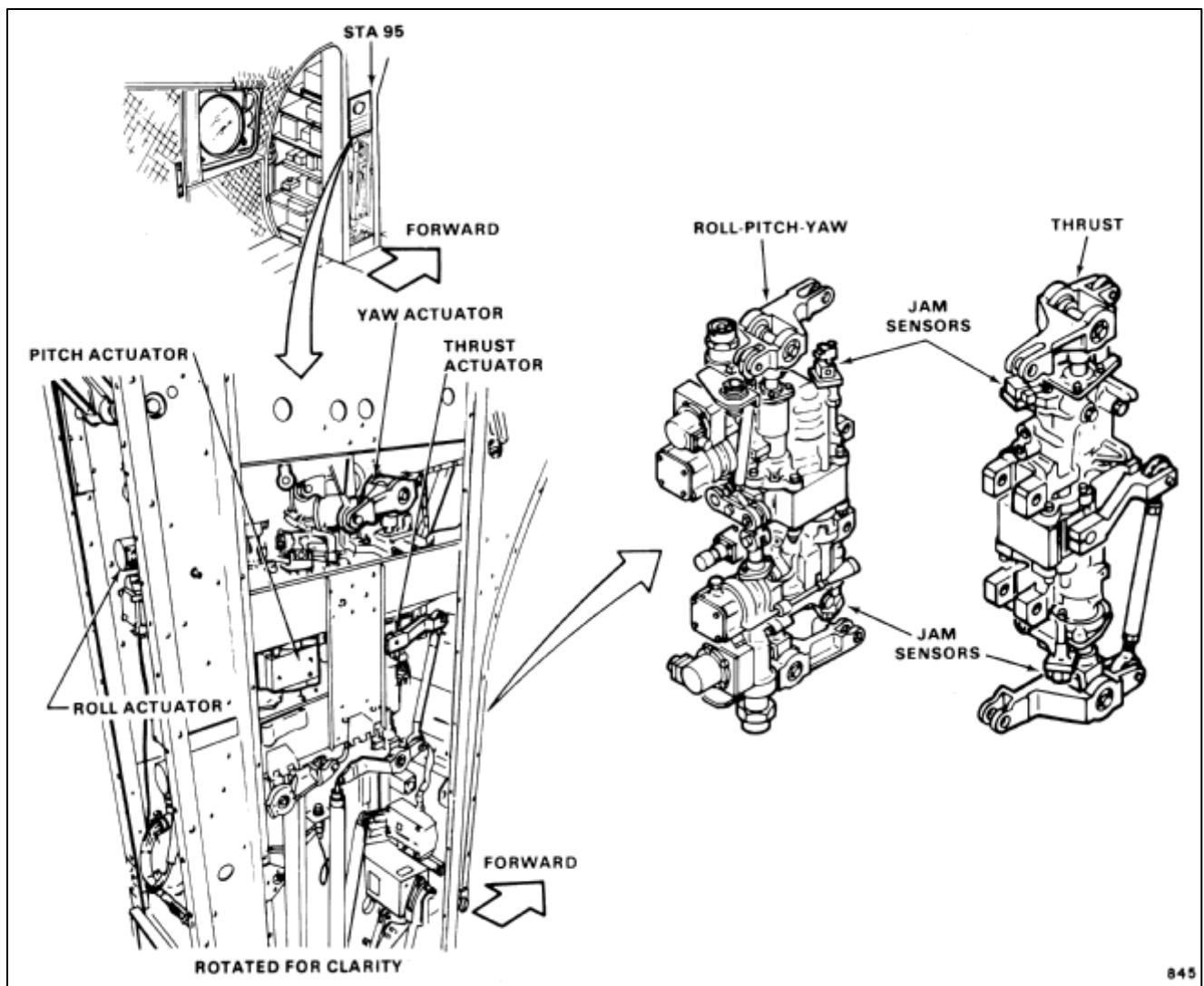

845

1. Set FLT CONTR switch (1) to BOTH.
2. SET AFCS SYSTEM SEL switch (3) to OFF.
3. Set flight controls (2) in approximately neutral position.

CAUTION

Do not use a steel tool to depress the button. Use hand pressure with a drift made of softer material such as aluminum, brass or wood to depress the button. Excessive force applied to the jam button may damage the button requiring replacement of the entire actuator assembly.

NOTE

Clean the jam button with a clean cloth prior to performing the test.

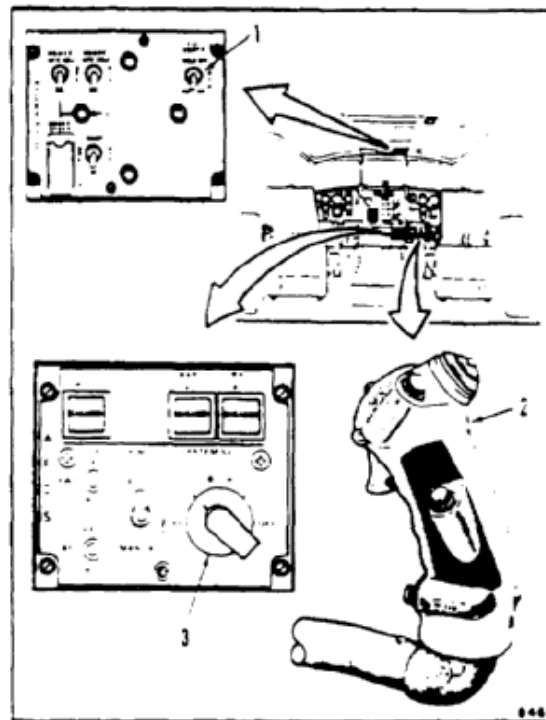

4. Depress selected ILCA jam simulation button.
5. Jam sensor indicator (5) shall extend. If jam sensor indicator does not extend, replace actuator (Tasks 7-84 and 7-102).
6. Press jam sensor indicator (5) into sensor housing (6). If jam sensor indicator will not reset, cycle flight controls slowly and return controls to neutral position.
7. Again, reset jam sensor indicator (5). Press into sensor housing (6). Depress jam simulation button (4) flush with surface of housing.
8. If jam simulator button (4) cannot be fully depressed flush with surface of housing (6), or if jam sensor indicator (5) cannot be reset, replace ILCA actuator (Tasks 7-84 and 7-102) and take contamination sample of flight control hydraulic fluid (Task 7-8.1).

NOTE

If ILCA actuator fails above test and no replace ILCA is available or field requirements do not allow for immediate replacement, perform Task 7-104.2, TEST ILCA JAM SENSORS-PHASE II, prior to **FIRST flight of EACH DAY**.

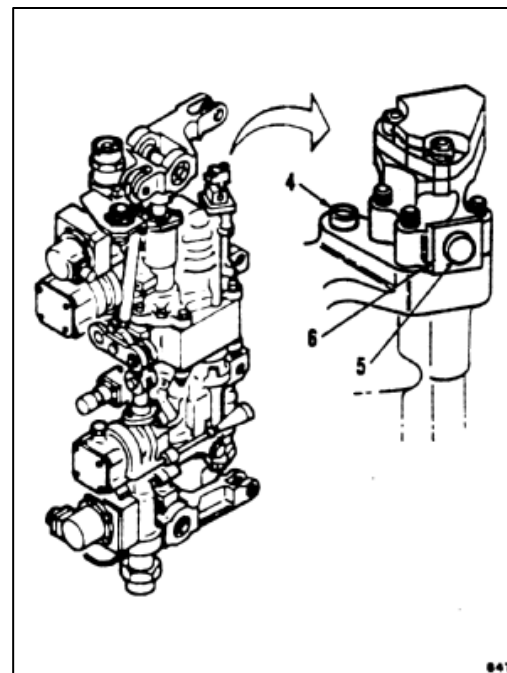

INSPECT***FOLLOW-ON MAINTENANCE:***

- Electrical power off.
- Battery disconnected (Task 1-39).
- Hydraulic power off.
- Control closet panel installed (Task 2-2).
- Control closet acoustic blanket installed (Task 2-210).

END OF TASK

INITIAL SETUP

Applicable Configurations:

All

Tools:

Hydraulic Repairer's Tool Kit, NSN 5180-00-323-4891

Materials:

None

Personnel Required:

Medium Helicopter Repairer
 Aircraft Pneudraulics Repairer
 Inspector

Equipment Condition:

Control Closet Acoustic Blanket Removed (Task 2-107)
 Controls Closet Panel Removed (Task 2-2)
 Electrical Power On
 Flight Controls Neutral
 Hydraulic Power Off
 Battery Connected (Task 1-39)

WARNING

This task shall be performed prior to **first flight of each day** until ILCA is replaced with one that passes PHASE 1 TEST (Task 7-104.1).

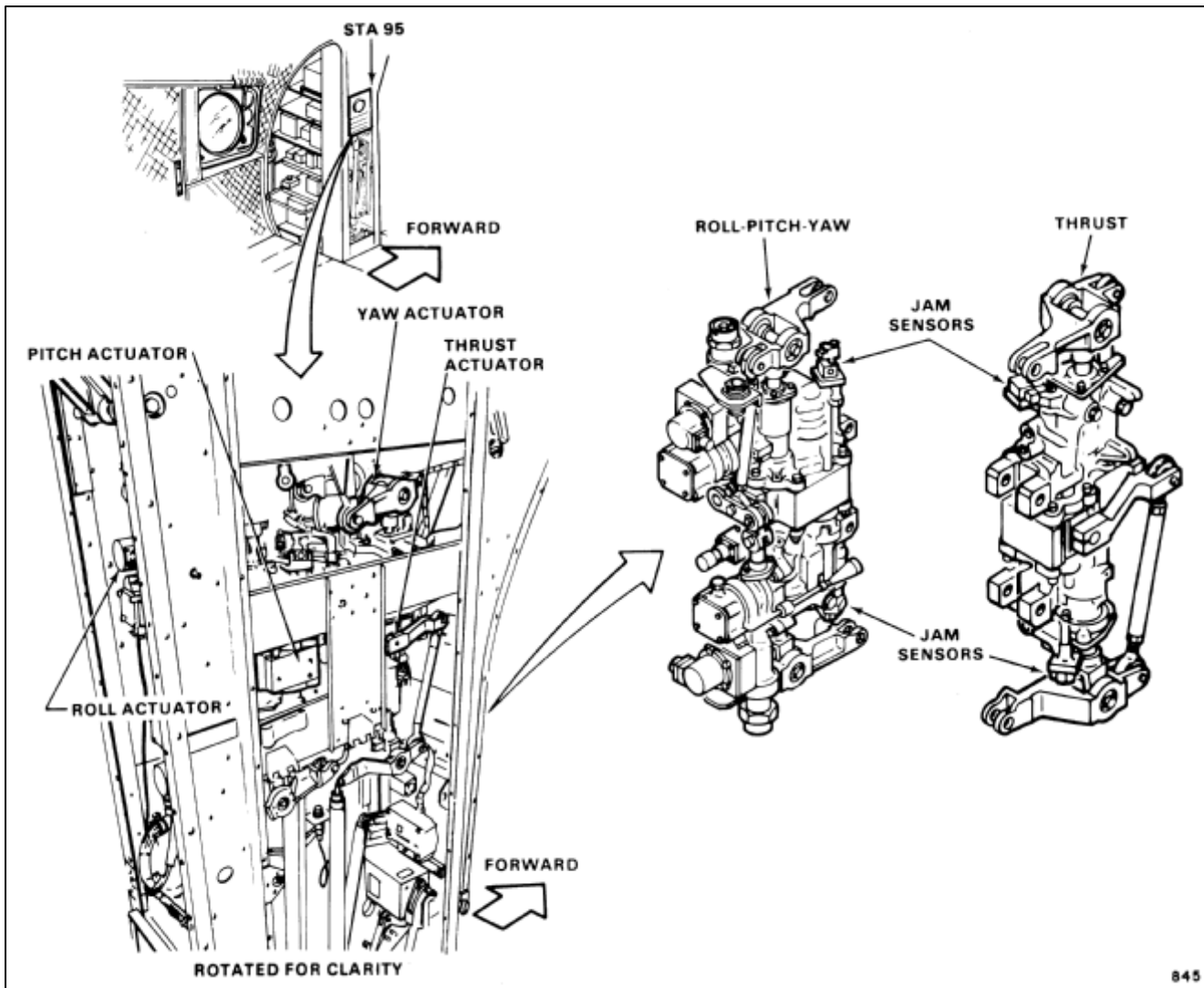

NOTE

This task is to be followed if suspect ILCA fails PHASE I TEST (Task 7-104.1) and no replacement ILCA is available or field requirements do not allow for immediate replacement.

1. Set FLT CONTR switch (1) to BOTH.
2. Set AFCS SYSTEM SEL switch (3) to OFF.
3. DEPRESS and HOLD centering device release switch (4) on cyclic stick (2) while inspecting the suspect roll, pitch or yaw ILCAs as follows.
4. Grasp input control rod (5) to the suspect ILCA and move it up and down.
5. Observe that the control valve lever on the side of the ILCA housing moves freely between the machined mechanical stops.

NOTE

Motion must exhibit NO binding and POSITIVELY contact the mechanical stops by solid feel. If condition exists, proceed to step 10 and perform remaining task steps.

6. Release the centering device release switch (4) on the cyclic stick (2).

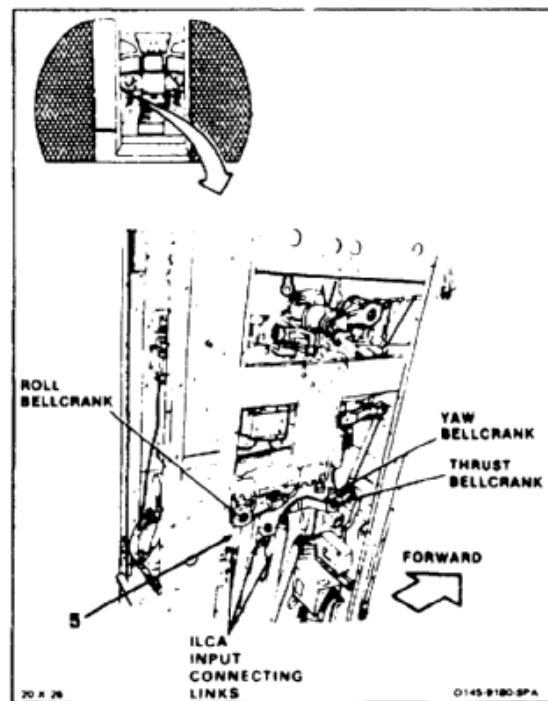
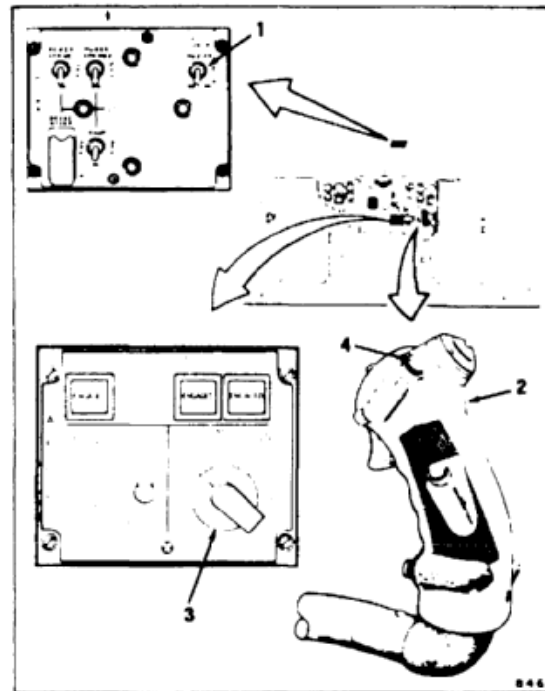

NOTE

Inspection of the thrust ILCA will differ slightly from pitch, roll and yaw ILCAs.

Only about **70 percent** of the control valve motion can be obtained without hydraulic pressure. Due to the thrust lever contacting its down stop before the stop on the thrust ILCA is reached.

However, there is sufficient movement of the control valve to determine binding if condition exists.

7. To inspect the thrust ILCA depress and hold the thrust control brake trigger (8) located on the trust grip (7).
8. Grasping the thrust ILCA input control rod (9), repeat TEST steps 4 and 5 with the thrust ILCA control valve lever (10).
9. Release thrust control brake trigger (8).

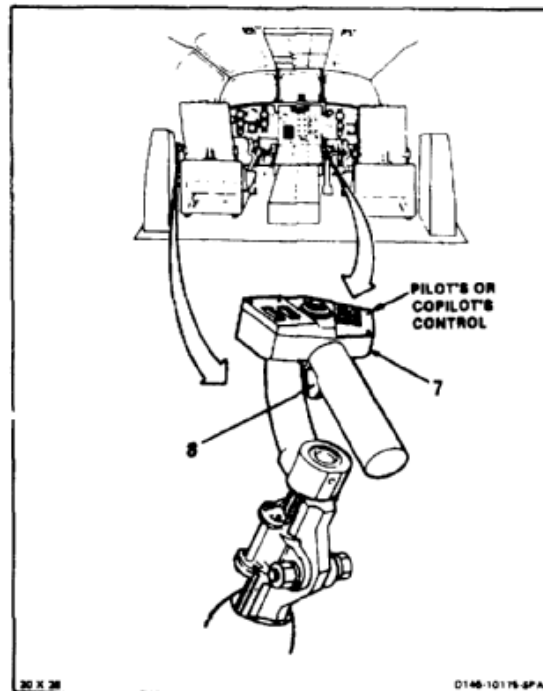

NOTE

If it has been determined that there is high friction or binding within the normal operating range (between stops) of the control valve on the thrust ILCA, proceed with step 10.

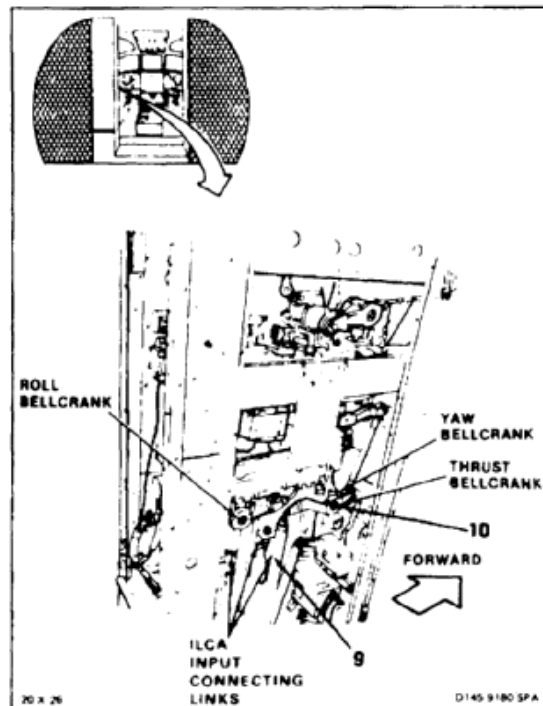

7-104.2 TEST ILCA JAM SENSORS — PHASE II (Continued)**7-104.2**

10. Disconnect the input control rod from the input lever of the suspect ILCA.
11. Move the input lever up and down within the range of its stops. The lever must move freely without binding.
12. Any high friction, binding or erratic movement of the control valve is cause for the replacement of the ILCA.



Insure that the input control rod removed from a suspect ILCA is reinstalled in accordance with Task 7-102.

INSPECT***FOLLOW-ON MAINTENANCE:***

- Electrical power off.
- Battery disconnected (Task 1-39).
- Control closet panel installed (Task 2-2).
- Control closet acoustic blanket installed (Task 2-210).

END OF TASK

INITIAL SETUP

Applicable Configurations:

All

Tools:

Aircraft Mechanic's Tool Kit, NSN 5180-00-323-4692

Materials:

Cloths (E135)

Personnel Required:

Medium Helicopter Repairer

Equipment Condition:

- Battery Disconnected (Task 1-39)
- Electrical Power Off
- Hydraulic Power Off
- Flight Control Hydraulic System Depressurized (Task 1-63)
- Power Drain No. 1 or No. 2 Flight Control Hydraulic System Reservoir (Task 1-60.1 or 1-61.1)
- Manual Drain Flight Control Hydraulic System Reservoir (Task 7-113)
- Right Forward Work Platform or Left Pylon Access Panel Open (Task 2-2)

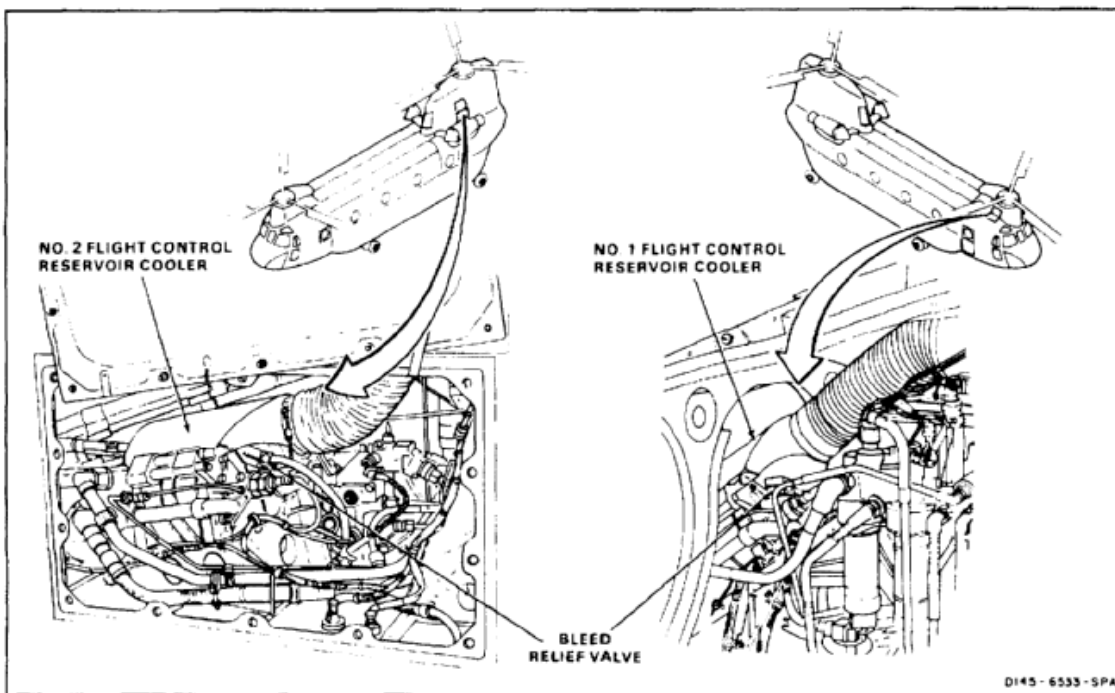

D145-6533-SPA

7-105 REMOVE NO. 1 OR NO. 2 FLIGHT CONTROL RESERVOIR/COOLER BLEED/RELIEF VALVE (Continued)

7-105

NOTE

Procedure is same to remove No. 1 or No. 2 flight control reservoir/cooler bleed/relief valve. Removal of No. 2 bleed/relief valve is shown here.

1. Loosen clamp (1) on hose (2). Disconnect hose (2) from valve (3). Use cloths (E135) for spilled fluid.
2. Remove lockwire from two screws (4).
3. Remove two screws (4) from valve (3).
4. Remove valve (3) and packing (5). Use cloths (E135) for spilled fluid.

FOLLOW-ON MAINTENANCE:

None

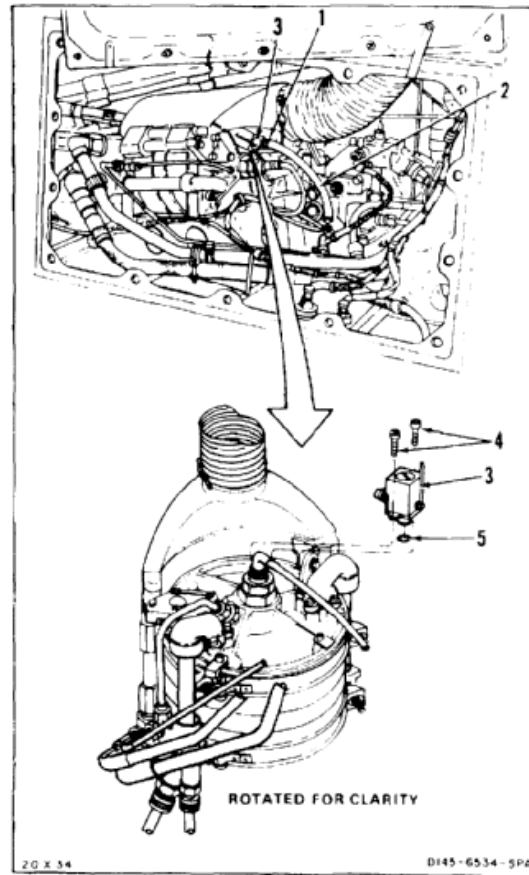

END OF TASK

7-501

INITIAL SETUP

Applicable Configurations:

All

Tools:

Aircraft Mechanic's Tool Kit, NSN 5180-00-323-4692

Materials:

Lockwire (E231)

Personnel Required:

Medium Helicopter Repairer
Inspector

Parts:

Preformed Packing

References:

TM 55-1520-240-23P

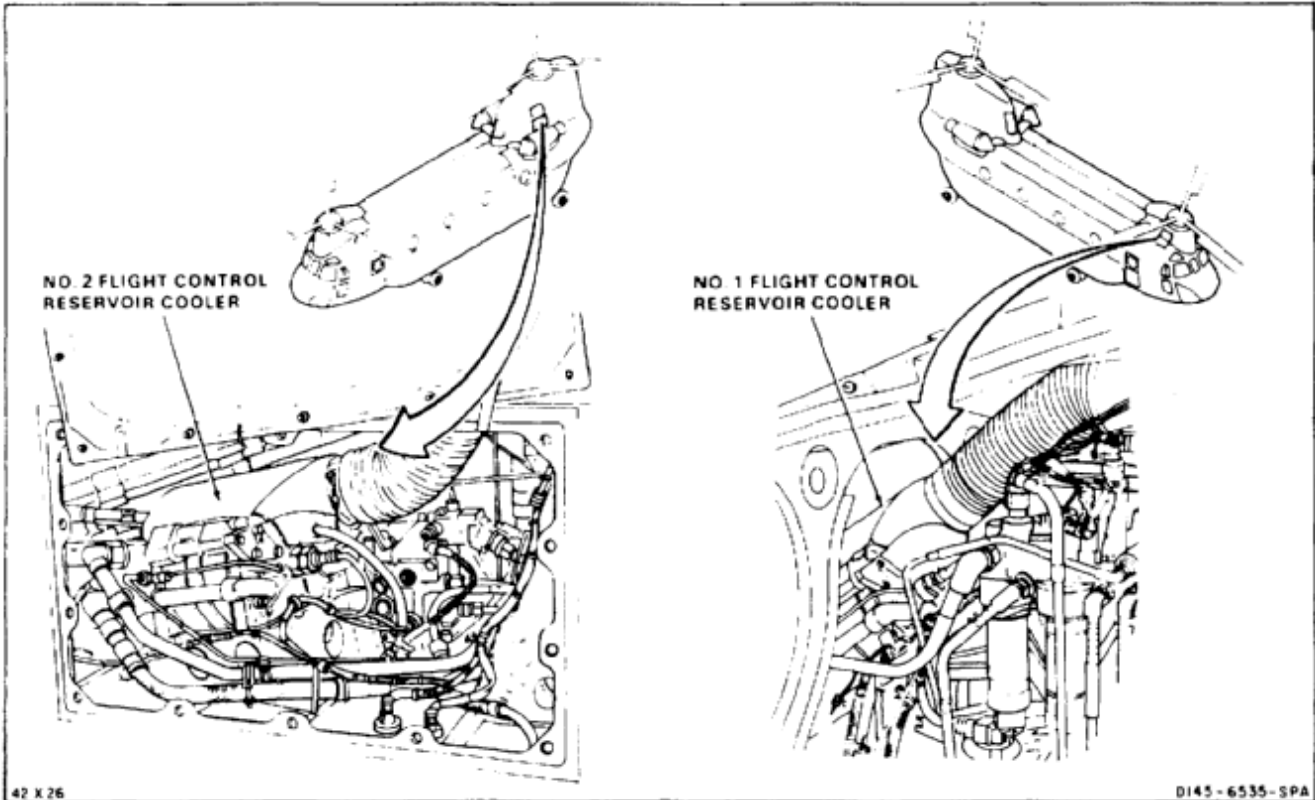

7-106 INSTALL NO. 1 OR NO. 2 FLIGHT CONTROL RESERVOIR/COOLER BLEED/RELIEF VALVE (Continued)

7-106

NOTE

Procedure is same to install No. 1 or No. 2 bleed/relief valve. Installation of No. 2 bleed/relief valve is shown here.

1. Install valve (1) and packing (2) in port (3).
2. Install two screws (4) in valve (1).
3. Lockwire two screws (4). Use lockwire (E231).
4. Install hose (5) and clamp (6). Tighten clamp.

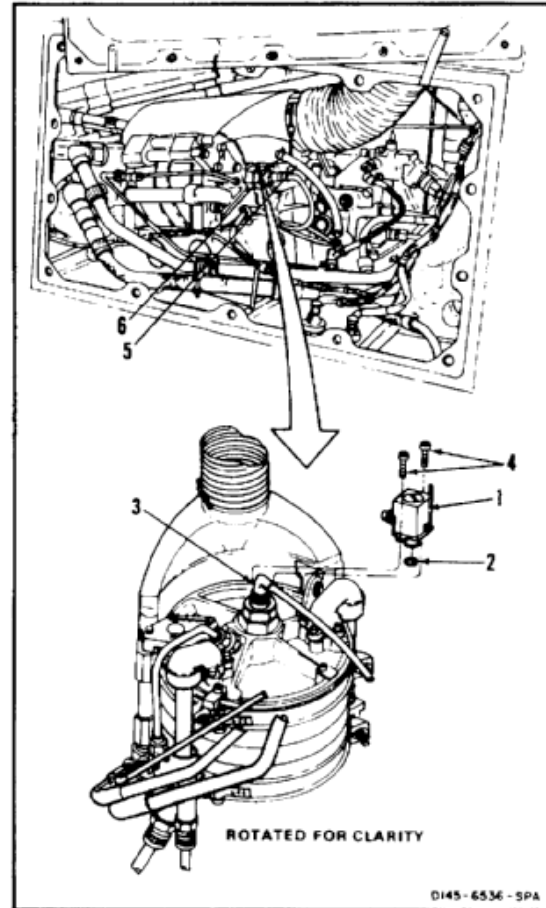
INSPECT**FOLLOW-ON MAINTENANCE:**

- Service reservoir/cooler (Task 1-60, 1-61, or 1-62).
- Bleed flight control hydraulic system (Task 7-16).
- Perform operational check of flight control system (TM 55-1520-240-T).
- Close right forward work platform or left pylon access panel (Task 2-2).

END OF TASK

INITIAL SETUP

Applicable Configurations:

All

Tools:

Aircraft Mechanic's Tool Kit, NSN 5180-00-323-4692
 Container, 2 Quart

Materials:

Cloths (E135)
 Gloves (E186)

Personnel Required:

Medium Helicopter Repairer

Equipment Condition:

Battery Disconnected (Task 1-39)
 Electrical Power Off
 Hydraulic Power Off
 Flight Control Hydraulic System Depressurized (Task 1-63)
 Power Drain No. 1 or No. 2 Flight Control Hydraulic System Reservoir (Task 1-60.1 or 1-61.1)

Manual Drain Flight Control Hydraulic System Reservoir (Task 7-113)
 Right Forward Work Platform or Left Pylon Access Panel Open (Task 2-2)

General Safety Instructions:

WARNING

Hydraulic fluid (E199) is toxic. It can irritate skin and cause burns. Avoid inhaling. Use only with adequate ventilation. Avoid contact with skin, eyes, or clothing. In case of contact, immediately flush skin or eyes with water for at least **15 minutes**. Get medical attention for eyes.

WARNING

Hydraulic fluid ejected under pressure can cause injury to personnel. Hydraulic fluid sprayed into the air is a fire hazard.

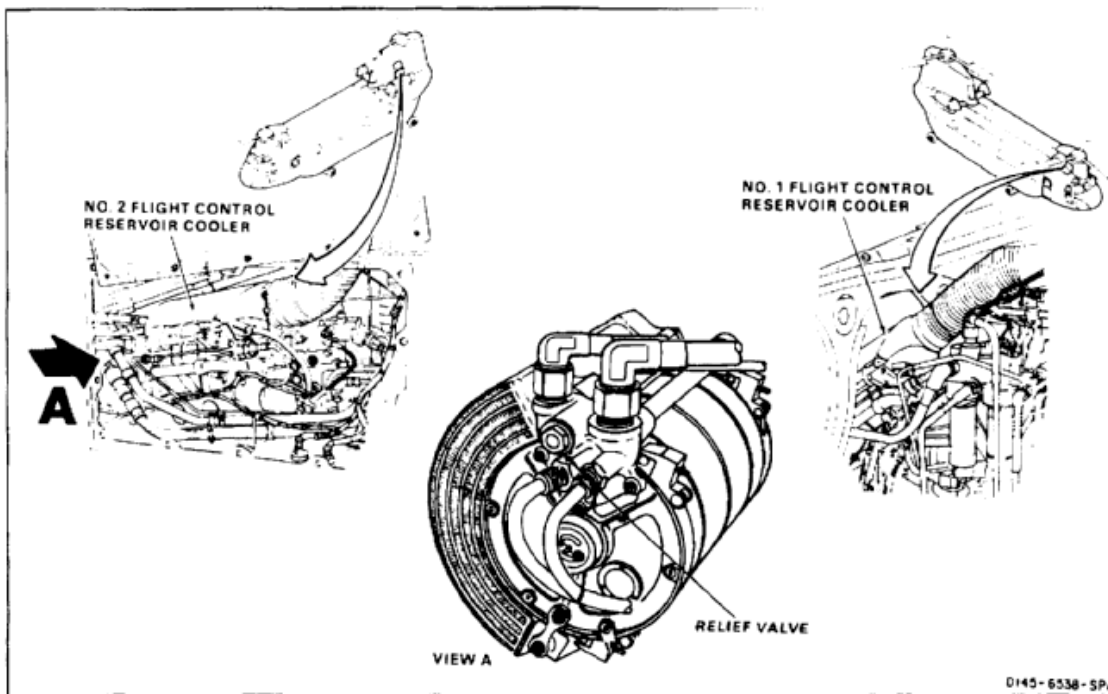

NOTE

Procedure is same to remove relief valve from No. 1 or No. 2 flight control reservoir/cooler. Removal of No. 2 relief valve is shown here.

1. Loosen clamp (1) on hose (2). Disconnect hose from tee (3). Use gloves (E186).
2. Open valve (4) and drain reservoir/cooler (5). Use container and cloths (E135) for spilled fluid.
3. Close valve (4). Connect hose (2) to tee (3). Tighten clamp (1).
4. Remove lockwire from valve (4), switch (6), and bulb (7).
5. Remove valve (4), two packings (8), and retainers (9). Use cloths (E135) for spilled fluid.

FOLLOW-ON MAINTENANCE:

None

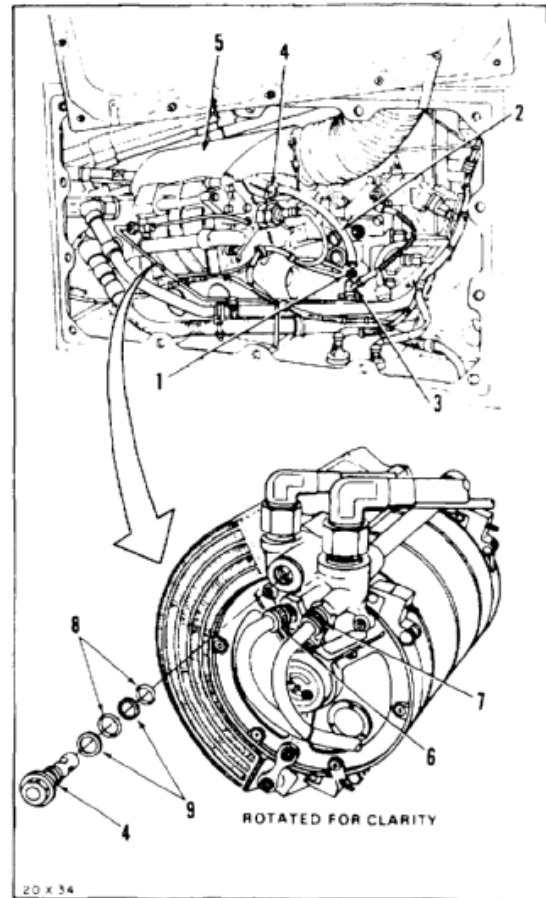

END OF TASK

INITIAL SETUP

Applicable Configurations:

All

Tools:

Aircraft Mechanic's Tool Kit, NSN 5180-00-323-4692

Materials:

Lockwire (E231)

Parts:

Preformed Packings
Retainers

Personnel Required:

Medium Helicopter Repairer
Inspector

References:

TM 55-1520-240-23P

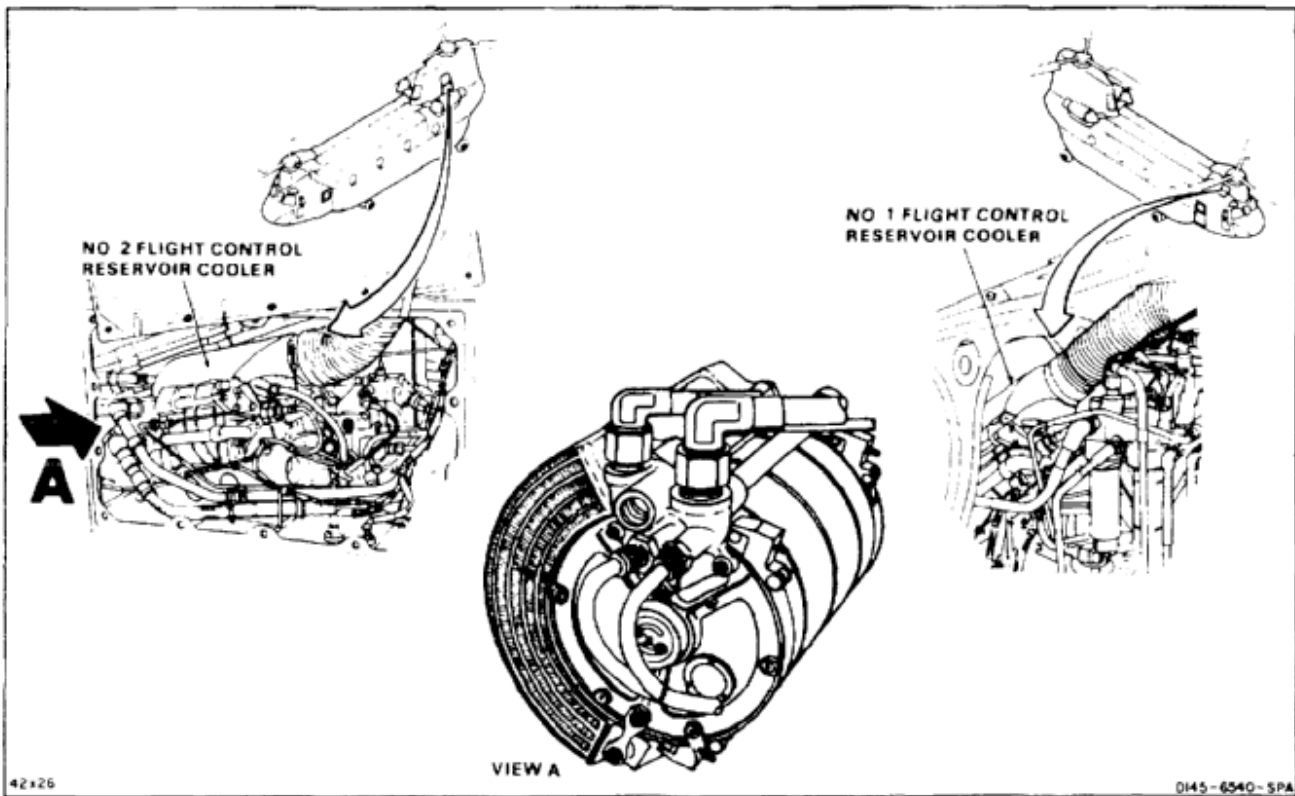

NOTE

Procedure is same to install No. 1 or No. 2 flight control reservoir/cooler relief valve.

1. Install valve (1), retainer (2), packing (3), retainer (4), and packing (5) in port (6).
2. Lockwire valve (1), switch (7) and bulb (8). Use lockwire (E231).

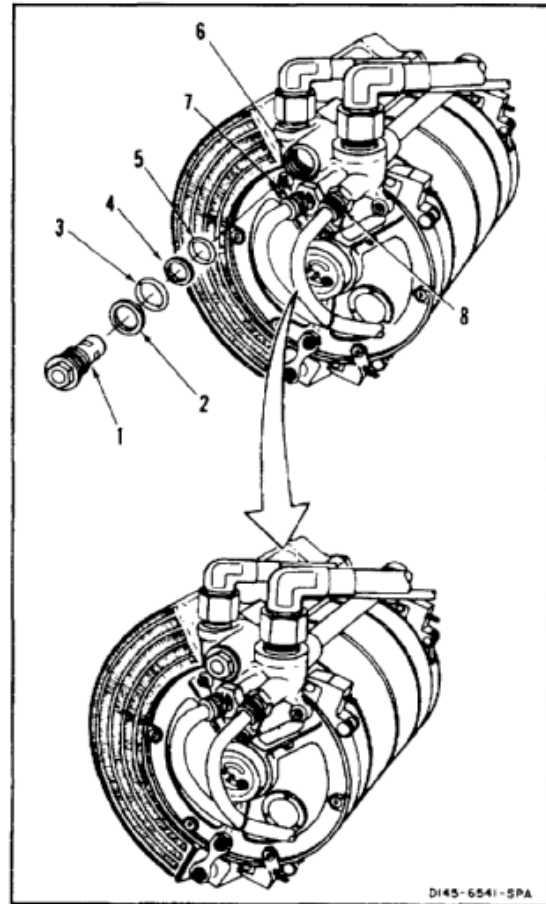
INSPECT**FOLLOW-ON MAINTENANCE:**

- Service reservoir/cooler (Task 1-60, 1-61, or 1-62).
- Bleed flight control hydraulic system (Task 7-16).
- Perform operational check of flight control system (TM 55-1520-240-T).
- Close right forward work platform or left pylon access panel (Task 2-2).

END OF TASK

INITIAL SETUP

Applicable Configurations:

All

Tools:

Aircraft Mechanic's Tool Kit, NSN 5180-00-323-4692
 Container, 2 Quart

Materials:

Cloths (E135)
 Gloves (E186)

Personnel Required:

Medium Helicopter Repairer

Equipment Condition:

Battery Disconnected (Task 1-39)
 Electrical Power Off
 Hydraulic Power Off
 Flight Control Hydraulic System Depressurized (Task 1-63)
 Power Drain No. 1 or No. 2 Flight Control Hydraulic System Reservoir (Task 1-60.1 or 1-61.1)
 Manually Drain Flight Control Hydraulic System Reservoir (Refer to Task 7-113)

Right Forward Work Platform or Left Pylon Access Panel Open (Task 2-2)
 Right Forward Access Panel Open (Task 2-2)

General Safety Instructions:

WARNING

Hydraulic fluid (E199) is toxic. It can irritate skin and cause burns. Avoid inhaling. Use only with adequate ventilation. Avoid contact with skin, eyes, or clothing. In case of contact, immediately flush skin or eyes with water for at least **15 minutes**. Get medical attention for eyes.

WARNING

Hydraulic fluid ejected under pressure can cause injury to personnel. Hydraulic fluid sprayed into the air is a fire hazard.

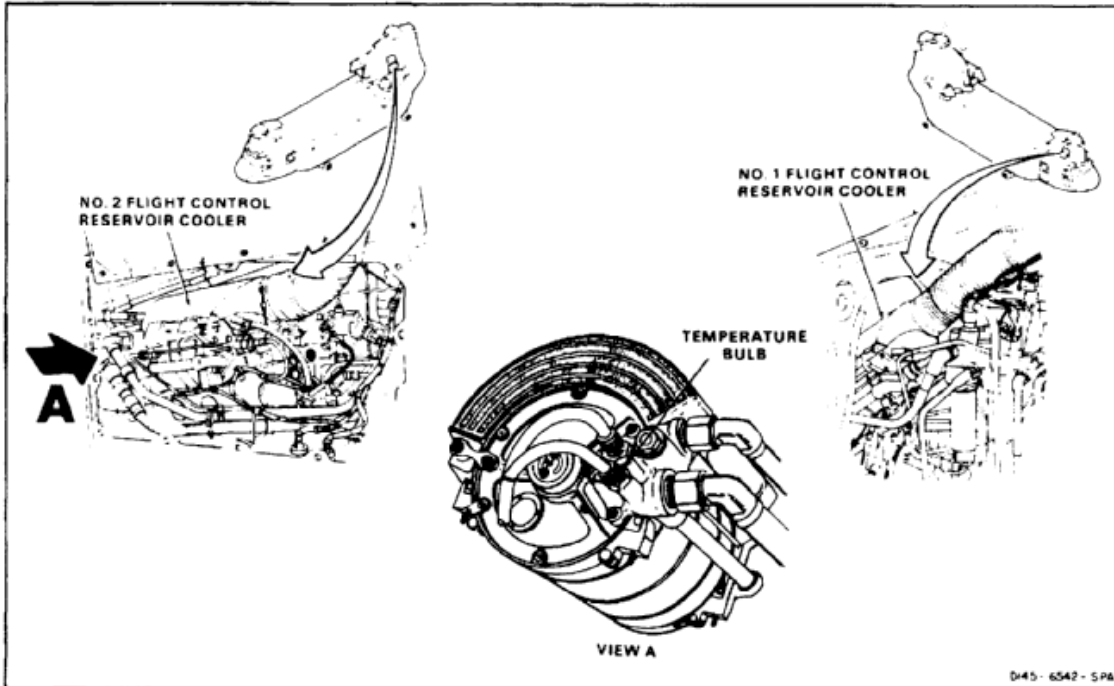

7-109 REMOVE NO. 1 OR NO. 2 FLIGHT CONTROL RESERVOIR/COOLER TEMPERATURE BULB (Continued)

7-109

NOTE

Procedure is same to remove temperature bulb from No. 1 or No. 2 flight control reservoir/cooler. Removal of No. 2 temperature bulb is shown here.

1. Open valve (1) and drain reservoir/cooler (2) through drain (3). Use container and cloths (E135) for spilled fluid. Use gloves (E186).
2. Close valve (1).

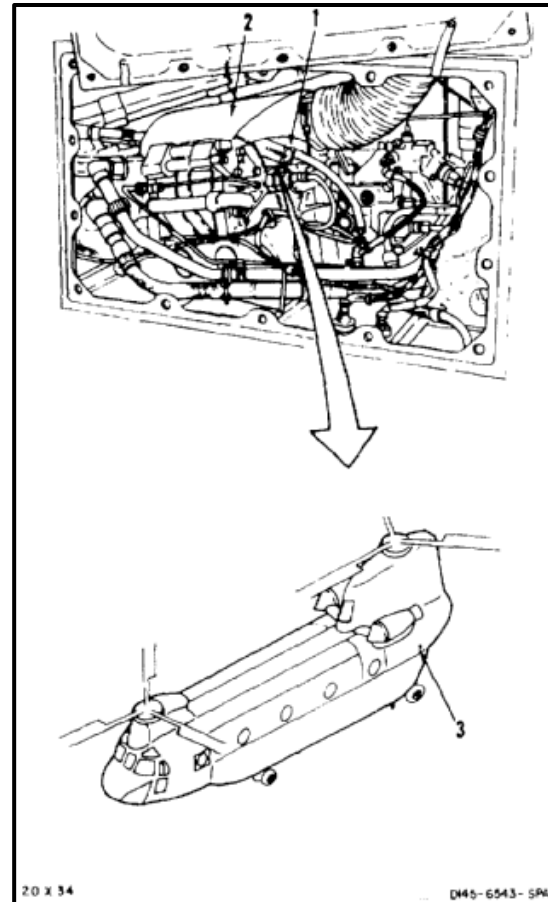

3. Disconnect electrical connector (4) from bulb (5).
4. Remove lockwire from valve (6), bulb (5), and switch (7).
5. Remove bulb (5) and packing (8) from reservoir/cooler (2). Use cloths (E135) for spilled fluid.

FOLLOW-ON MAINTENANCE:

None

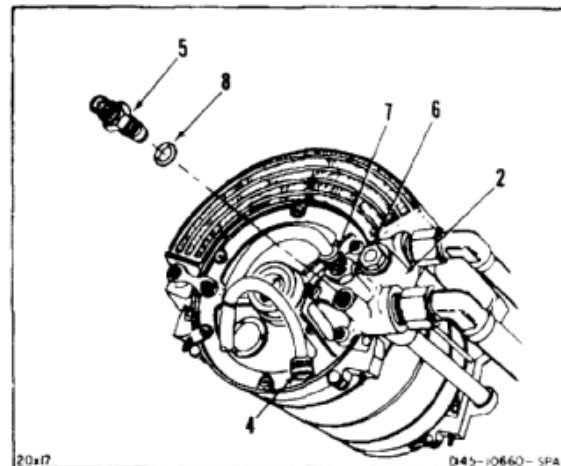

END OF TASK

7-509

INITIAL SETUP

Applicable Configurations:

All

Tools:

Aircraft Mechanic's Tool Kit, NSN 5180-00-323-4692

Materials:

Lockwire (E231)

Parts:

Preformed Packing

Personnel Required:

Medium Helicopter Repairer
Inspector

References:

TM 55-1520-240-23P

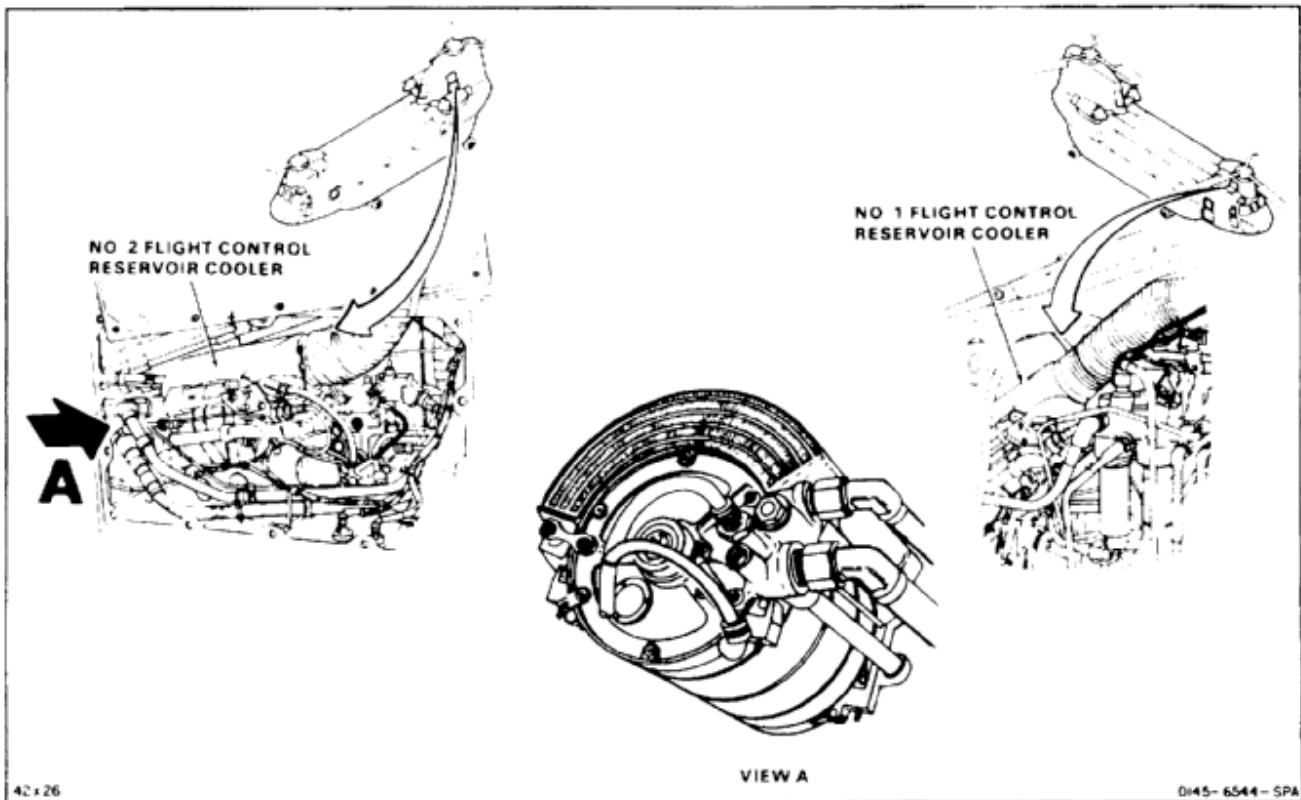

7-110 INSTALL NO. 1 OR NO. 2 FLIGHT CONTROL RESERVOIR/COOLER TEMPERATURE BULB (Continued)

7-110

NOTE

Procedure is same to install No. 1 or No. 2 flight control reservoir/cooler temperature bulb.

1. Install bulb (1) and packing (2) in port (3).
2. Connect electrical connector (4) to bulb (1).
3. Lockwire bulb (1), switch (5), and valve (6). Use lockwire (E231).

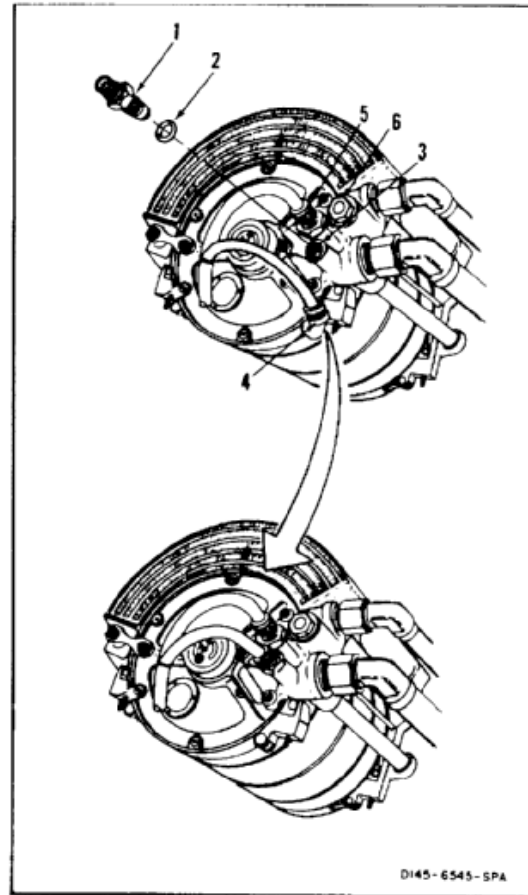
INSPECT**FOLLOW-ON MAINTENANCE:**

- Service reservoir/cooler (Task 1-60, 1-61, or 1-62).
- Bleed flight control hydraulic system (Task 7-16).
- Perform operational check of flight control system (TM 55-1520-240-T).
- Close right forward access panel (Task 2-2).
- Close right forward work platform or left pylon access panel (Task 2-2).

END OF TASK

INITIAL SETUP

Right Forward Work Platform or Left Pylon Access Panel Open (Task 2-2)
 Right Forward Access Panel Open (Task 2-2)

Applicable Configurations:

All

Tools:

Aircraft Mechanic's Tool Kit, NSN 5180-00-323-4692
 Container, 2 Quart

Materials:

Cloths (E135)
 Gloves (E186)

Personnel Required:

Medium Helicopter Repairer

Equipment Condition:

Battery Disconnected (Task 1-39)
 Electrical Power Off
 Hydraulic Power Off
 Flight Control Hydraulic System Depressurized (Task 1-63)
 Power Drain No. 1 or No. 2 Flight Control Hydraulic System Reservoir (Task 1-60.1 or 1-61.1)
 Manually Drain Flight Control Hydraulic System Reservoir (Refer to Task 7-113)

General Safety Instructions:

WARNING

Hydraulic fluid (E199) is toxic. It can irritate skin and cause burns. Avoid inhaling. Use only with adequate ventilation. Avoid contact with skin, eyes, or clothing. In case of contact, immediately flush skin or eyes with water for at least **15 minutes**. Get medical attention for eyes.

WARNING

Hydraulic fluid ejected under pressure can cause injury to personnel. Hydraulic fluid sprayed into the air is a fire hazard.

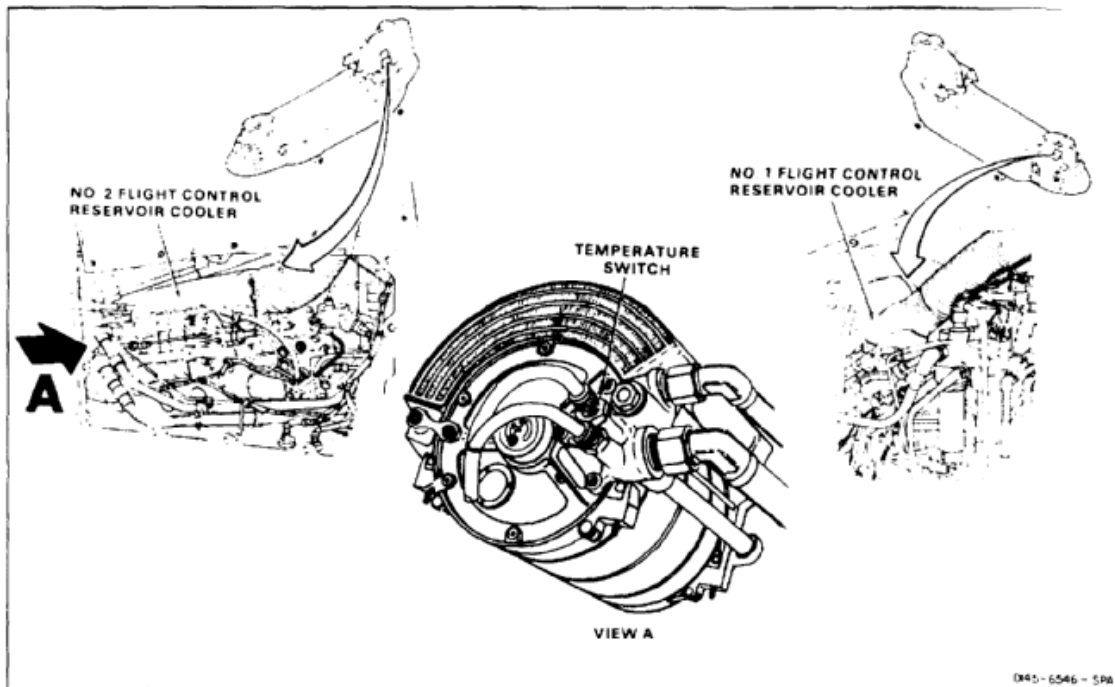

7-111 REMOVE NO. 1 OR NO. 2 FLIGHT CONTROL RESERVOIR/COOLER TEMPERATURE SWITCH (Continued)

7-111

NOTE

Procedure is same to remove temperature switch from No. 1 or No. 2 flight control reservoir/cooler. Removal of No. 2 temperature bulb is shown here.

1. Open valve (1) and drain reservoir/cooler (2) through drain (3). Use container and cloths (E135) for spilled fluid. Use gloves (E186).
2. Close valve (1).

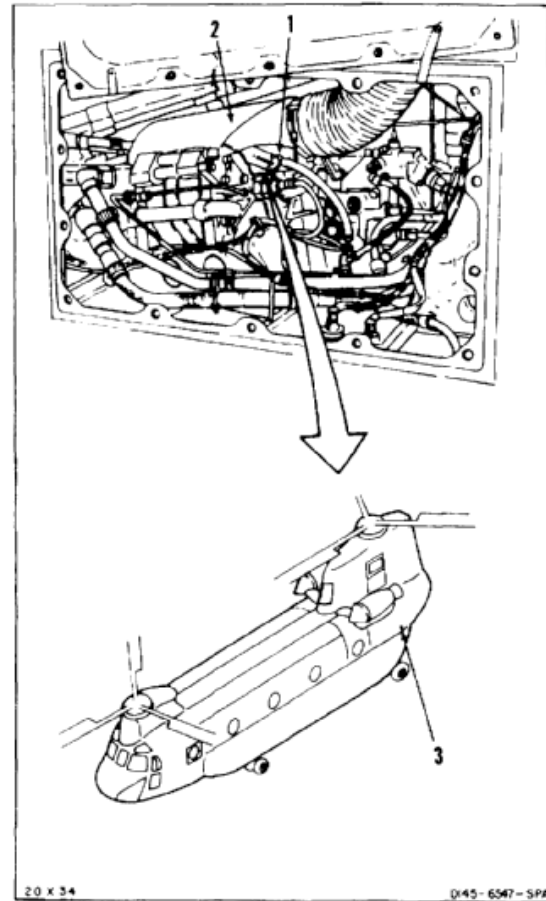

3. Disconnect electrical connector (4) from switch (5).
4. Remove lockwire from valve (6), bulb (7), and switch (5).
5. Remove switch (5) and packing (8) from port (9). Use cloths (E135) for spilled fluid.

FOLLOW-ON MAINTENANCE:

None

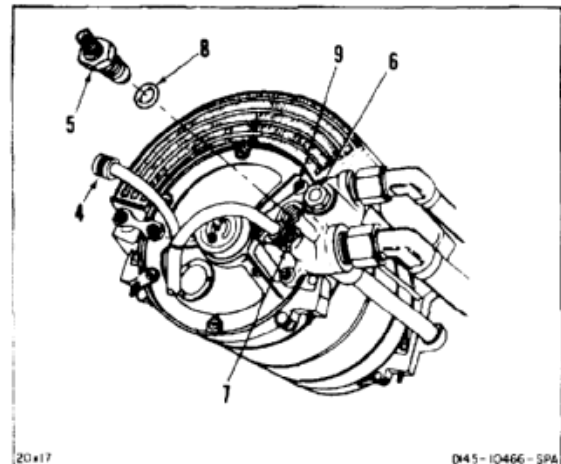

END OF TASK

7-513

INITIAL SETUP

Applicable Configurations:

All

Tools:

Aircraft Mechanic's Tool Kit, NSN 5180-00-323-4692

Materials:

Lockwire (E231)

Parts:

Preformed Packing

Personnel Required:

Medium Helicopter Repairer
Inspector

References:

TM 55-1520-240-23P

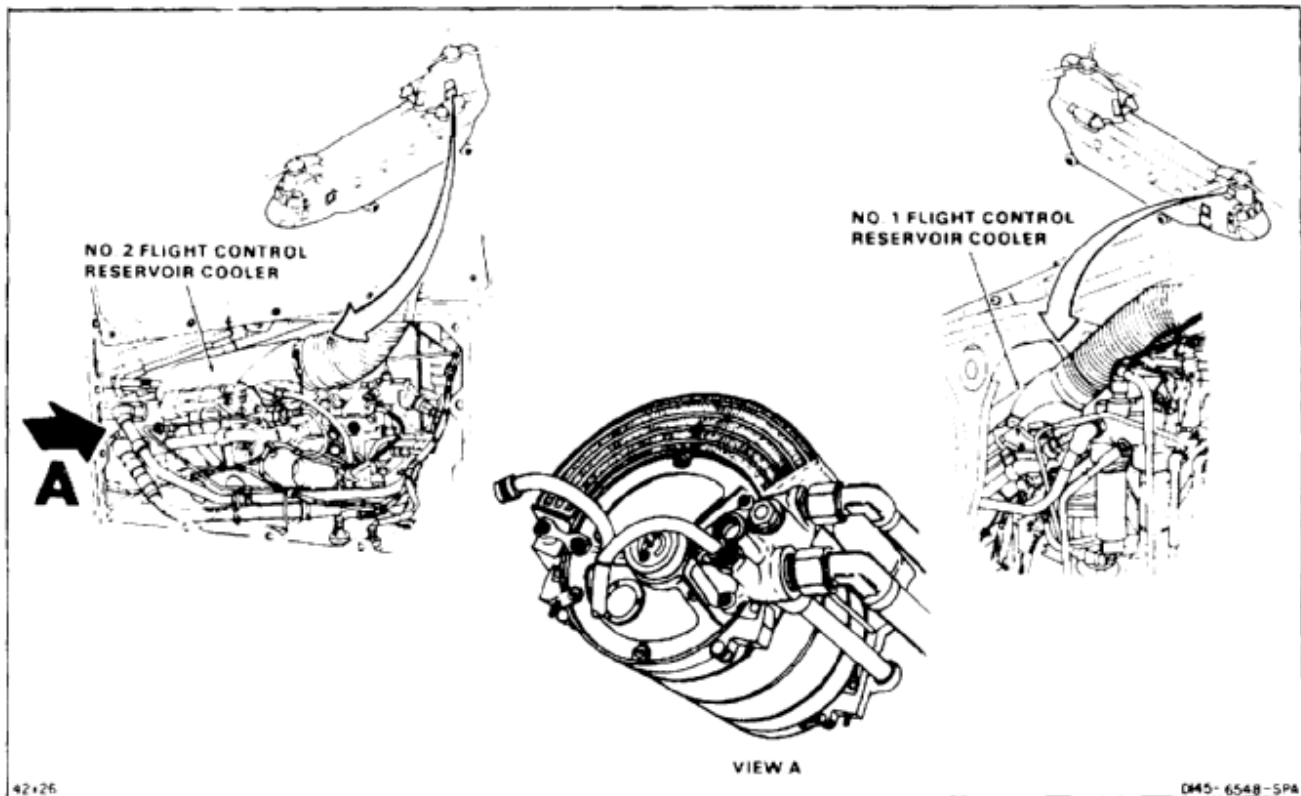

42+26

DM5-6548-5PA

7-112 INSTALL NO. 1 OR NO. 2 FLIGHT CONTROL RESERVOIR/COOLER TEMPERATURE SWITCH (Continued)

7-112

NOTE

Procedure is same to install No. 1 or No. 2 flight control reservoir/cooler temperature switch.

1. Install switch (1) and packing (2) in port (3).
2. Connect electrical connector (4) to switch (1).
3. Lockwire switch (1), bulb (5), and valve (6). Use lockwire (E231).

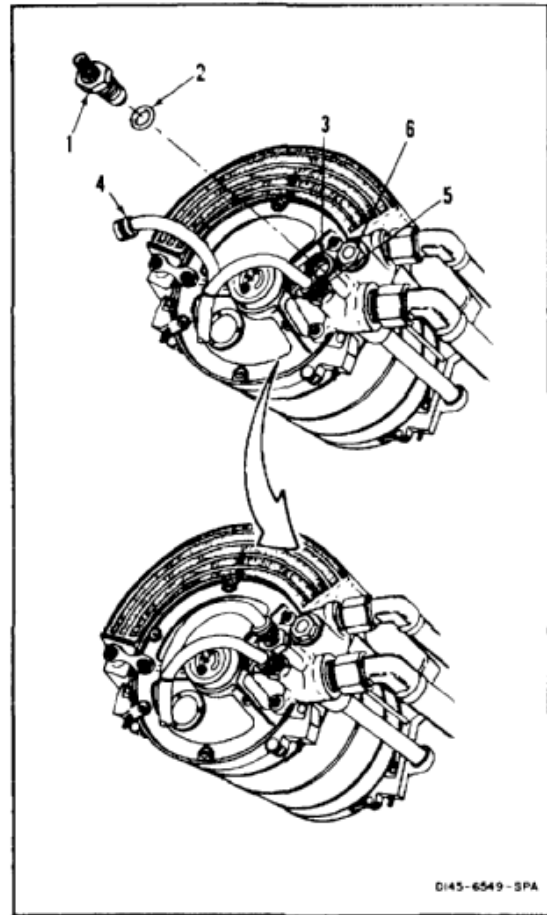
INSPECT**FOLLOW-ON MAINTENANCE:**

- Service reservoir/cooler (Task 1-60, 1-61, or 1-62).
- Bleed flight control hydraulic system (Task 7-16).
- Perform operational check of flight control system (TM 55-1520-240-T).
- Close right forward access panel (Task 2-2).
- Close right forward work platform or left pylon access panel (Task 2-2).

END OF TASK

INITIAL SETUP

Right Forward Work Platform or Left Pylon Access
Panel Open (Task 2-2)

Applicable Configurations:

All

Tools:

Aircraft Mechanic's Tool Kit, NSN 5180-00-323-4692
Open End Wrench, 1-1/4 Inch
Open End Wrench, 1-1/2 Inch
Container, 2 Quart

Materials:

Cloths (E135)
Paper Tags (E264)
Gloves (E186)

Personnel Required:

Medium Helicopter Repairer

Equipment Condition:

Battery Disconnected (Task 1-39)
Electrical Power Off
Hydraulic Power Off
Flight Control Hydraulic System Depressurized (Task
1-63)

General Safety Instructions:**WARNING**

Hydraulic fluid (E199) is toxic. It can irritate skin and cause burns. Avoid inhaling. Use only with adequate ventilation. Avoid contact with skin, eyes, or clothing. In case of contact, immediately flush skin or eyes with water for at least **15 minutes**. Get medical attention for eyes.

WARNING

Hydraulic fluid ejected under pressure can cause injury to personnel. Hydraulic fluid sprayed into the air is a fire hazard.

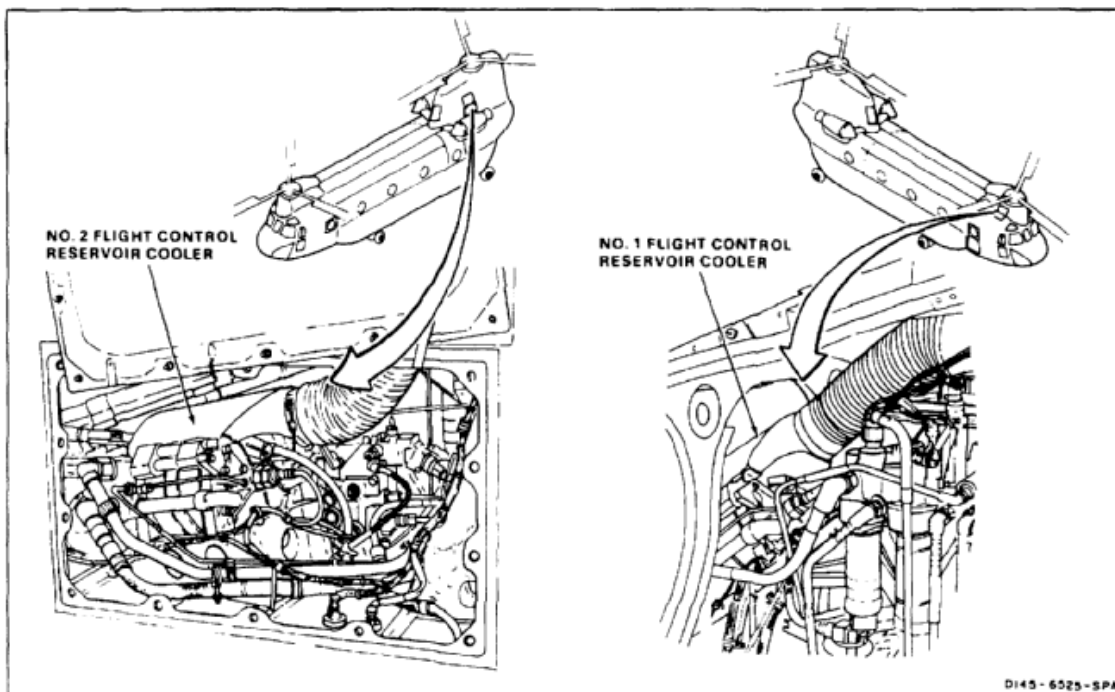

NOTE

Procedure is same to remove No. 1 or No. 2 flight control reservoir/cooler. Removal of No. 2 reservoir/cooler is shown here.

1. Loosen clamp (1) on hose (2). Disconnect hose from tee (3). Use gloves (E186).
2. Open valve (4) and drain reservoir/cooler (5). Use container and cloths (E135) for spilled fluid.
3. Close valve (4). Connect hose (2) to tee (3). Tighten clamp (1).
4. Loosen clamp (6). Slide clamp on duct (7). Disconnect duct from reservoir/cooler (5).
5. Loosen clamp (8). Slide clamp on hose (2). Disconnect hose from valve (4).
6. Tag and disconnect three tubes (9).
7. Tag and disconnect three electrical plugs (10).

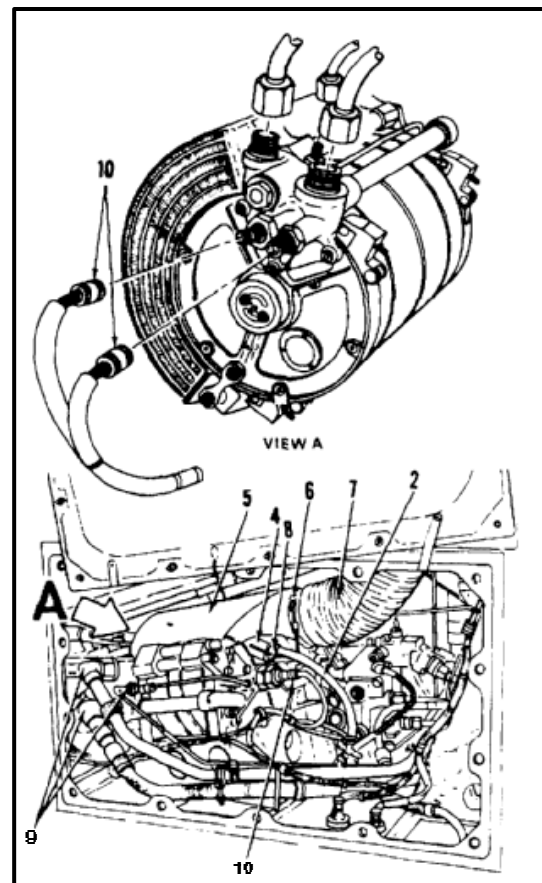
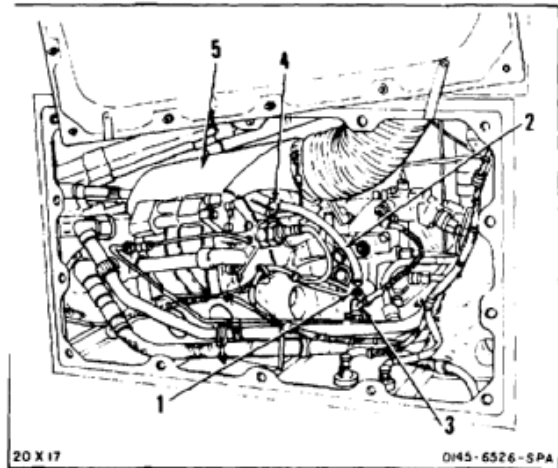

8. Remove four nuts (11) and eight washers (12).
9. Remove reservoir/cooler (5).

FOLLOW-ON MAINTENANCE:

None

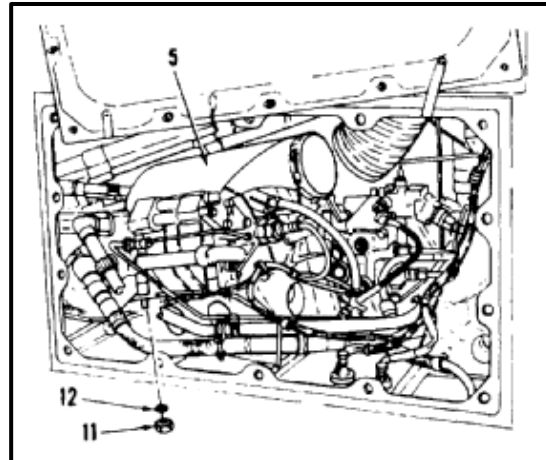

END OF TASK

7-518

INITIAL SETUP

Applicable Configurations:

All

Tools:

Hydraulic Repairer's Tool Kit, NSN 5180-00-323-4891
Container, 2 Quart
Deep Socket, 7/16 Inch
Technical Inspection Tool Kit, NSN 5180-00-323-5114
Outside Micrometer Caliper, 1 to 2 Inch

Materials:

Cloths (E120)

Personnel Required:

Aircraft Pneudraulics Repairer
Inspector

References:

TM 1-1520-253-23

Equipment Condition:

Off Helicopter Task

General Safety Instructions:**WARNING**

Hydraulic fluid (E199) is toxic. It can irritate skin and cause burns. Avoid inhaling. Use only with adequate ventilation. Avoid contact with skin, eyes, or clothing. In case of contact, immediately flush skin or eyes with water for at least **15 minutes**. Get medical attention for eyes.

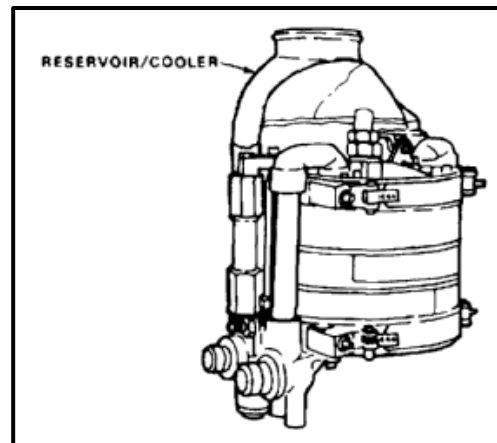

NOTE

General inspection criteria (Task 7-1.1) for obvious damage applies unless otherwise stated.

Inspection steps cover parts that are subject to wear.

1. Remove tube (1) between reservoir (2) and manifold (3).
- 1.1. Check tube (1) for dents and scratches. Dents shall not be deeper than **0.050 inch**. Scratches shall not be deeper than **0.004 inch**.
2. Remove lockwire, three screws (4), and washers (5). Remove manifold (3) with supply tube (6) from reservoir (2).

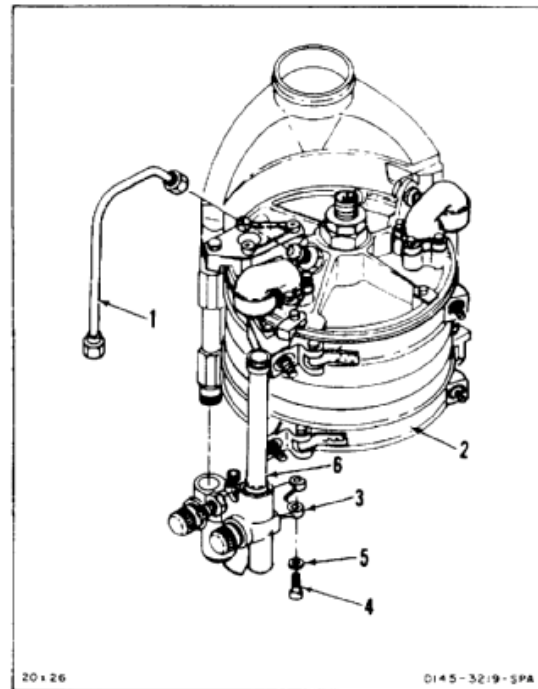

3. Remove nut (7) and elbow (8) from manifold (3).
4. Remove cotter pin (9), pin (10) and supply tube (6) from manifold (3).
5. Remove two packings (11) from tube (8).
- 5.1. Measure outside diameter of ends (11.1) of tube (6). Diameter shall not be less than **1.13 inches**. Ends shall not be out of round more than **0.003 inch**.
- 5.2. Check tube (6) for dents and scratches. Dents shall not be deeper than **0.180 inch**. Scratches shall not be deeper than **0.010 inch**.

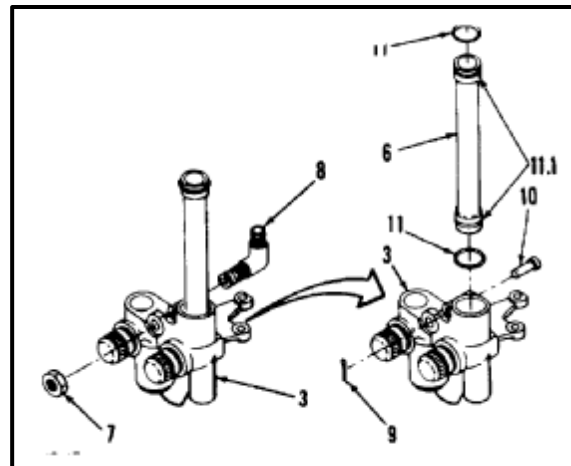

**7-114 DISASSEMBLE AND INSPECT FLIGHT CONTROL RESERVOIR/COOLER
(AVIM) (Continued)**

7-114

6. Remove lockwire, six screws (12), two joints (13) and two transfer tubes (14) from reservoir (2).
7. Remove two packings (15) from each tube (14).

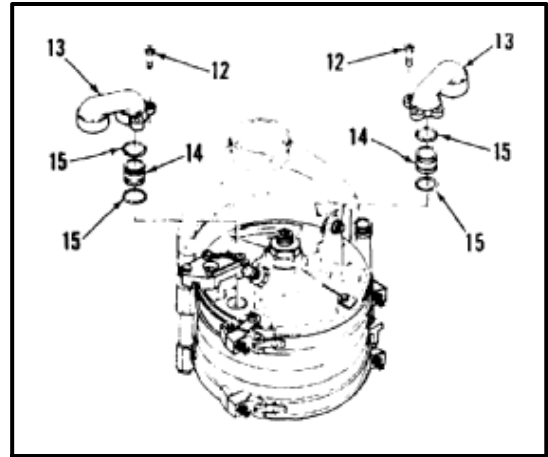

8. Remove nut (16), three washers (17), and screw (18) from reservoir (2) and cooler (19).
9. Remove lockwire, three screws (20) and washers (21) from bracket (22).
10. Remove two screws (23), two washers (24), and link (25).
11. Remove nipple (26) from reservoir (2).
12. Remove packing (27) from nipple (26).
13. Remove cooler (19) from reservoir (2).

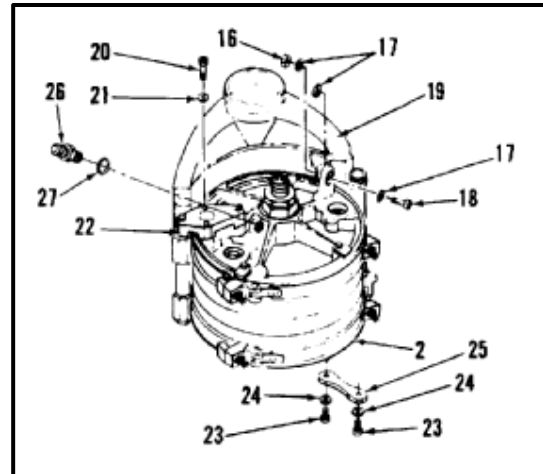

14. Remove cotter pin (28), pin (29), and return tube (30) from cooler (19).
15. Remove two packings (31) from tube (30). Inspect tube. (Refer to steps 5.1 and 5.2.)
16. Remove packing (32) from cooler (19).
17. Drain fluid from cooler (19). Use container for fluid. Use cloths (E120) to clean up spills. Use gloves (E186).
18. Remove bolt (33) and bracket (22) from cooler (19).
- 18.1. Check mounting flanges (33.1 and 33.2) of cooler (19). Flanges shall not be bent.
- 18.2. Check welds on cooler (19) for cracks. There shall be no cracks. If a crack is suspected, refer to TM 1-1520-253-23.
- 18.3. Check fins (33.3) at bottom of cooler (19). Straighten bent fins.

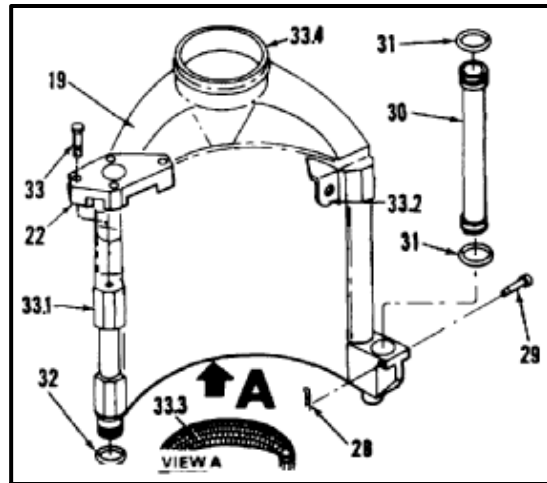

Heat will damage cooler.

- 18.4. Check neck (33.4) of cooler (19) for cracks and distortion. There shall be no cracks. Smooth distorted neck back to original shape. Do not apply heat. If a crack is suspected, refer to TM 1-1520-253-23.
- 18.5. Check strap mounts (34 and 35) for condition. There shall be no cracks or kinks. There shall be no broken welds. If a crack is suspected, refer to TM 1-1520-253-23.
19. If strap mount (34 or 35) is damaged, remove as follows:
 - a. Loosen one side of strap mount (34 or 35) enough to clear timing clamp (36). Use deep socket.
 - b. Lift strap mount (34 or 35) over timing clamp (36). Remove strap mount from reservoir (2).
20. Check reservoir (2) for condition. There shall be no cracks or dents. If a crack is suspected, refer to TM 1-1520-253-23.

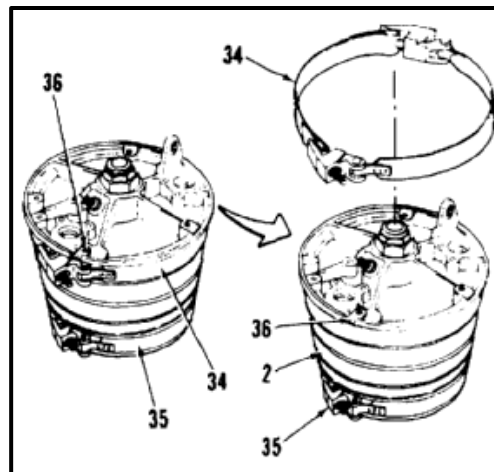

FOLLOW-ON MAINTENANCE:

None

END OF TASK

INITIAL SETUP

Applicable Configurations:

All

Tools:

Hydraulic Repairer's Tool Kit, NSN 5180-00-323-4891
 Torque Wrench, 5 to 50 Inch-Pounds
 Torque Wrench, 30 to 150 Inch-Pounds
 Deep Socket, 7/16 Inch

Materials:

Cloths (E120)
 Hydraulic Fluid (E199)
 Lockwire (E231)

Parts:

Cotter Pins
 Preformed Packings

Personnel Required:

Aircraft Pneudraulics Repairer
 Inspector

References:

TM 55-1520-240-23P

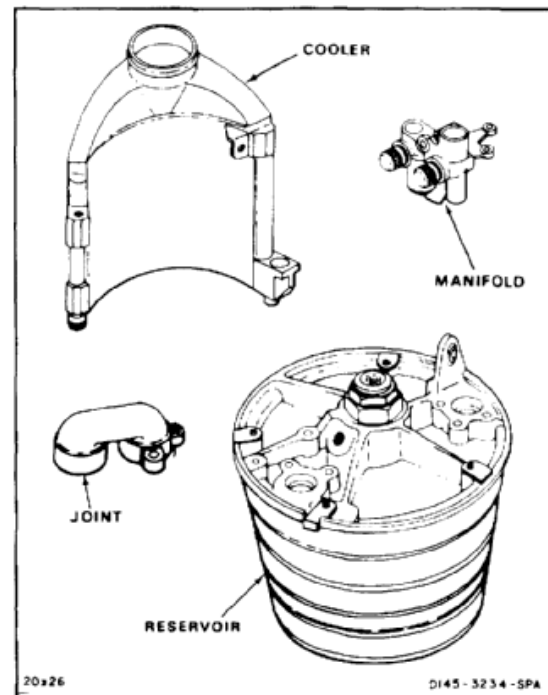

1. If strap mount (1 or 2) was removed from reservoir (3), install as follows:
 - a. Slide strap mounts (1 or 2) over timing clamp (3) and onto reservoir (4).
 - b. Align notch in strap mount (1 and 2) with timing clamp (3).



Too much torque will crack the clamps.

- c. Using the deep socket, alternately tighten nut on each side of strap mount (1 or 2). Torque strap mount to **50 to 60 inch-pounds**.
2. Measure length of thread extending through the nuts on each side of strap mount (1 or 2). Length shall be **0.75 to 0.95 inch**.
3. Install packing (5) on nipple (6).
4. Install nipple (6) in reservoir (4).

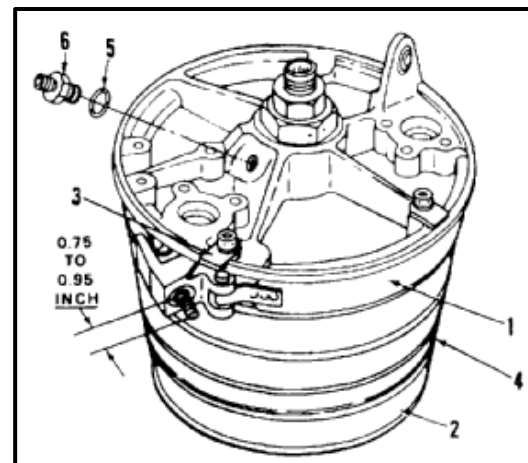

5. Install packing (7), on cooler (8).
6. Install two packings (9) on short return tube (10).
7. Install short return tube (10), pin (11), and cotter pin (12) in cooler (8).

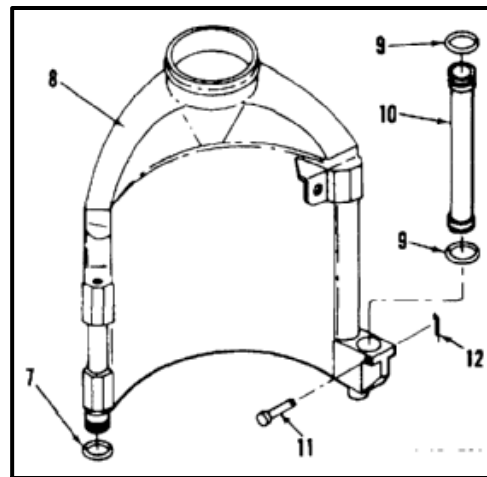

8. Position reservoir (4) on cooler (8).
9. Install link (13), two washers (14), and two screws (15) in reservoir (4) and cooler (8).
10. Install screw (16), three washers (17), and nut (18) in reservoir (4) and cooler (8).
11. Position bracket (19) on reservoir (4) and cooler (8). Install bolt (20).
12. Install three bolts (21) in bracket (19) and reservoir (4). Torque bolt (20) to **30 inch-pounds**. Torque bolts (21) to **55 inch-pounds**.
13. Lockwire bolts (21). Use lockwire (E231).

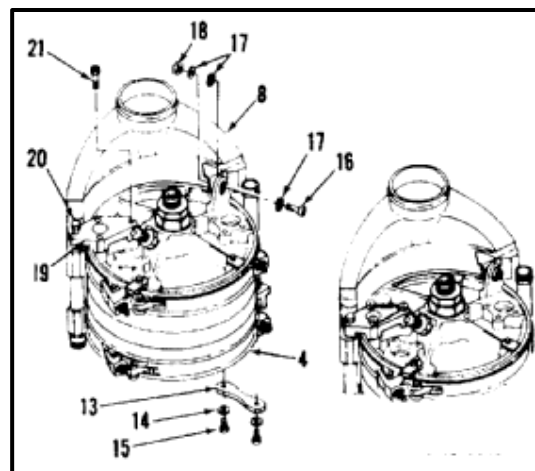

14. Install two packings (22) on supply tube (23).
15. Install supply tube (23), pin (24), and cotter pin (25) in manifold (26).
16. Install elbow (27) and nut (28) in manifold (26).

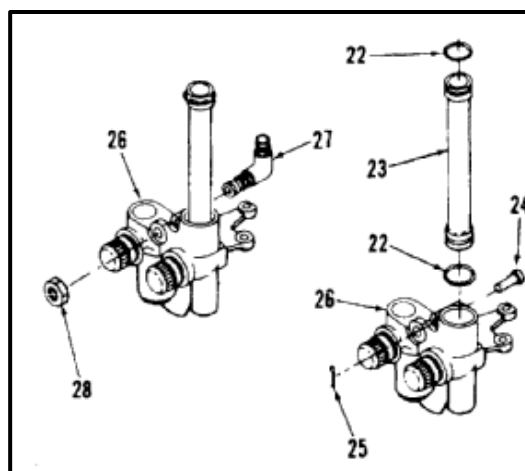

7-115 ASSEMBLE FLIGHT CONTROL RESERVOIR/COOLER (AVIM) (Continued)

7-115

17. Install manifold (26), three screws (29) and washers (30) on reservoir (4). Torque screws to **30 inch-pounds**.
18. Lockwire screw (29). Use lockwire (E231).
19. Install tube (31) between reservoir (4) and manifold (26).

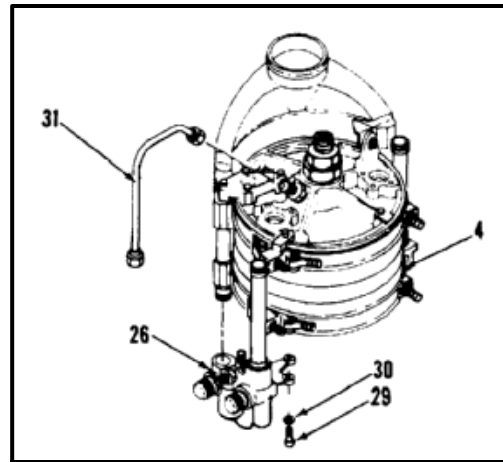

20. Install two packings (32) on each transfer tube (33).
21. Install two transfer tubes (33) in cover (34).
22. Position one joint (35) between cover (34) and manifold supply tube (23). Install three screws (36).
23. Position other joint (35) between cover (34) and cooler return tube (10). Install three screws (36).
24. Torque six screws (36) to **20 inch-pounds**. Lockwire six screws. Use lockwire (E231).

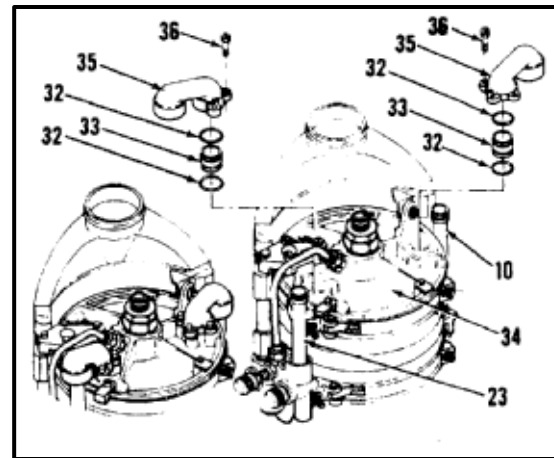
**FOLLOW-ON MAINTENANCE:**

Test flight control reservoir/cooler (Task 7-116).

END OF TASK

INITIAL SETUP

Applicable Configurations:

All

Tools:

- Hydraulic Repairer's Tool Kit, NSN 5180-00-323-4891
- Signal Generator, Capable of 5 Volt rms, 10 ma at 450Hz
- Hydraulic Test Stand
- Hydraulic Hand Pump
- Torque Wrench, 5 to 50 Inch-Pounds
- Digital Voltmeter
- Resistor, 100,000 Ohm
- Mini-ammeter
- Shutoff Valve (3)
- Gage, 0 to 30 psi
- Gage, 0 to 200 psi
- Container, 2 Quart
- Bleed Relief Valve, 145HS211-1
- Relief Valve, 145HS207-1
- Temperature Bulb, 1122153
- Thermal Switch, A15HS015-2
- Flexible Hose, 1/4 Inch, 0 to 4500 psi
- Flexible Hose, 1 Inch OD, 0 to 200 psi
- Flexible Hose, 3/4 Inch OD, 0 to 200 psi

Materials:

- Cloths (E120)
- Lockwire (E231)
- Marking Pencil (E271)
- Gloves (E186)

Parts:

Packings

Personnel Required:

- Aircraft Electrician
- Aircraft Pneudraulics Repairer
- Inspector

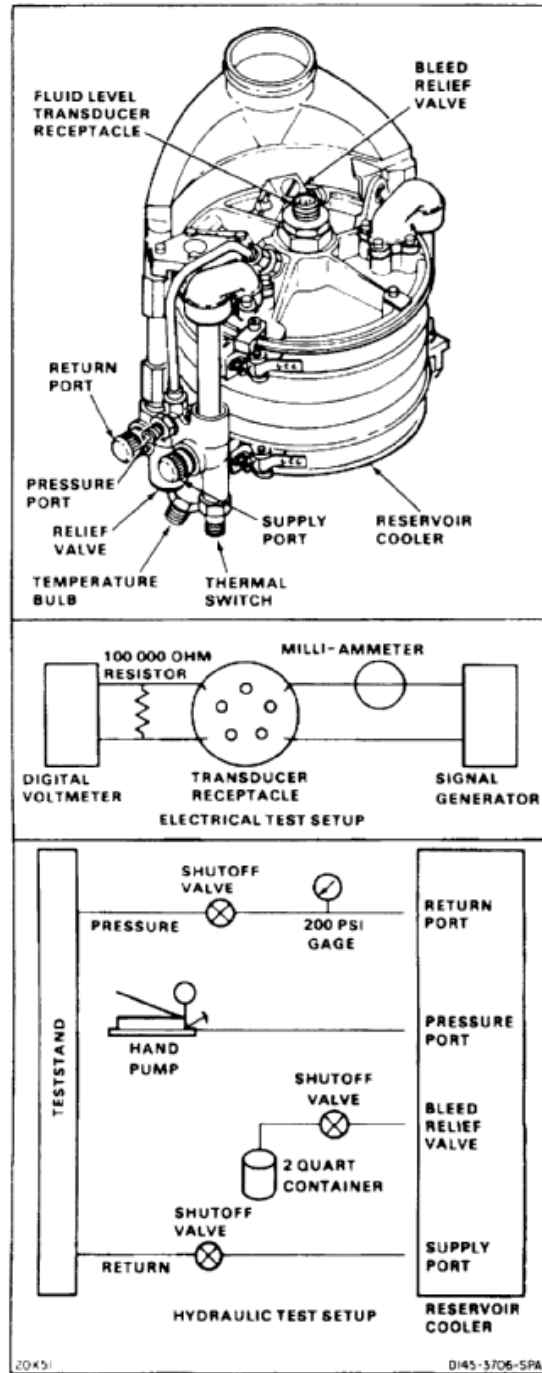

Equipment Condition:

Off Helicopter Task
Hydraulic Test Setup
Electrical Test Setup
Reservoir/Cooler Installed in Crash Proof Box
Bleed Relief Valve, Relief Valve, Temperature
Bulb, And Temperature Switch Installed on
Reservoir/Cooler

General Safety Instructions:**WARNING**

Reservoir/cooler must be installed in crash proof box before performing test. Otherwise, injury to personnel can occur.

WARNING

Hydraulic fluid (E199) is toxic. It can irritate skin and cause burns. Avoid inhaling. Use only with adequate ventilation. Avoid contact with skin, eyes, or clothing. In case of contact, immediately flush skin or eyes with water for at least **15 minutes**. Get medical attention for eyes.

WARNING

Hydraulic fluid ejected under pressure can cause injury to personnel.
Hydraulic fluid sprayed into the air is a fire hazard.

INTEGRITY PRESSURE TEST, LOW PRESSURE SIDE

1. Connect test setup pressure hose (1) to reservoir return port (2). Use gloves (E186).
2. Connect test setup return hose (3) to reservoir supply port (4).
3. Connect drain hose (5) to reservoir bleed relief valve (6).
4. Close shutoff valve (7).
5. Close shutoff valve (8).

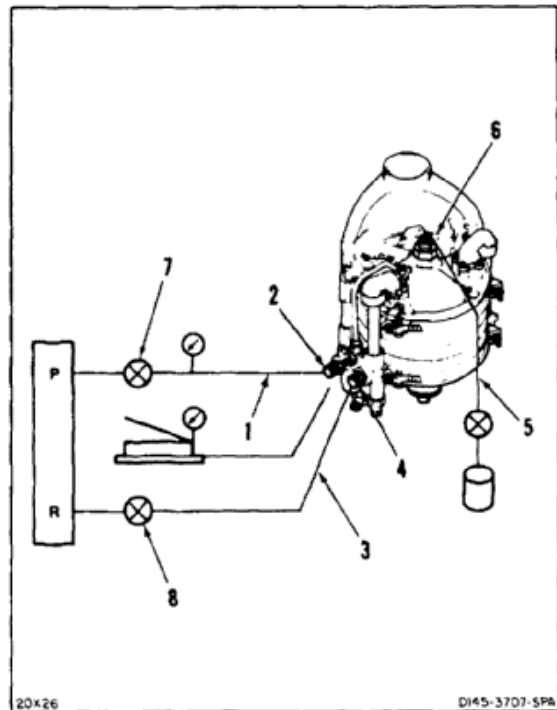

6. Open shutoff valve (7) and apply **5 to 20 psi** pressure to return port (2) to fill reservoir (9). Open shutoff valve (10) and hold bleed relief valve (6) open until reservoir is free of air.
7. Close shutoff valve (10).
8. Apply **120 psi** pressure to return port (2). Maintain pressure for **2 minutes**.
9. Check reservoir (9) for leaks. There shall be no external leaks.
10. Open shutoff valve (8).

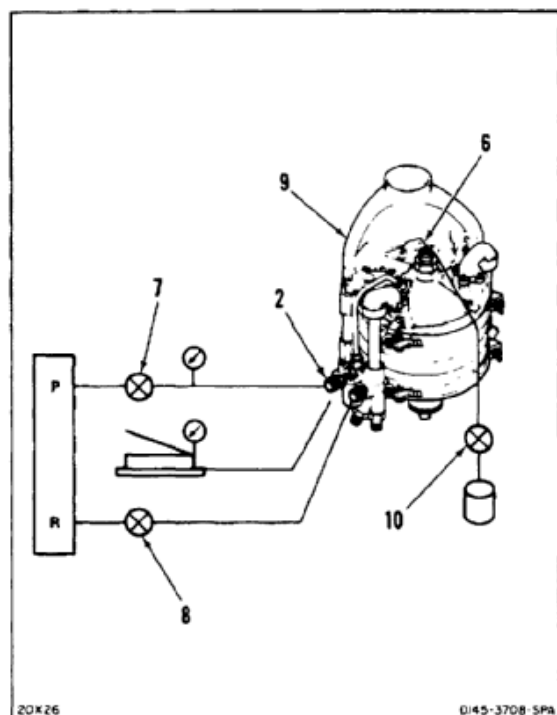

11. Close and open valve (7) to lower and raise pressure at return port (2) from **120 to 0 psi** twice.
12. Check reservoir (9) for leaks and smooth operation of cylinder (11). There shall be no leaks, erratic movement or sticking of cylinder.
13. Close shutoff valve (8).
14. Open valve (7) to raise pressure at return port (2) to **120 psi**. Maintain pressure for **2 minutes**.
15. Check reservoir (9) for leaks. There shall be no external leaks.
16. Open shutoff valve (8).
17. Close valve (7) to reduce pressure at return port (2) to **0 psi**.

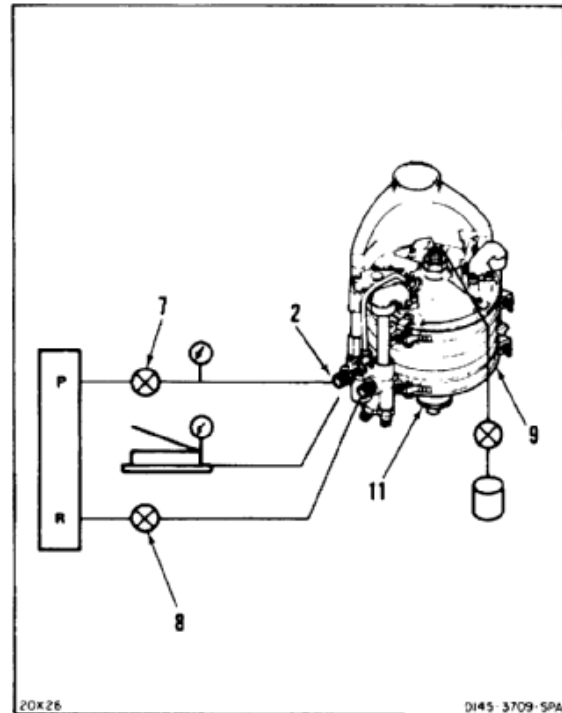

INTEGRITY PRESSURE TEST, HIGH PRESSURE SIDE

18. Connect hand pump pressure hose (12) to reservoir pressure port (13).
19. Open valve (7) and apply **60 psi** pressure to return port (2).
20. Close valves (7 and 8).
21. Make sure valve (14) is closed and apply **3350 psi** pressure to pressure port (13). Maintain pressure for **2 minutes**.
22. Check reservoir (9) for leaks. There shall be no external leaks.
23. Open shutoff valve (8).
24. Close and open valve (7) to lower and raise pressure at return port (2) between **120 psi and 0 psi**.
25. Check reservoir (9) for leaks and smooth operation of cylinder (11). There shall be no external leaks, erratic movement or sticking of cylinder.
26. Open valve (14) to reduce pressure at pressure port (13) to **0 psi**.
27. Close valve (7) to reduce pressure at return port (2) to **0 psi**.

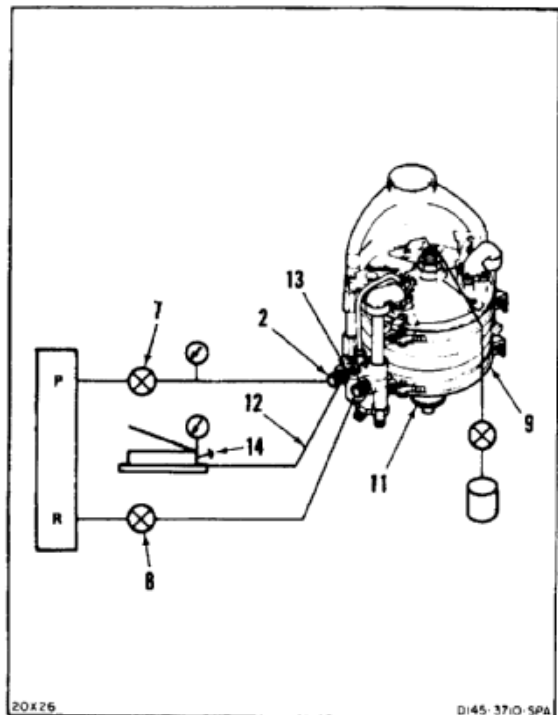

FLUID LEVEL TRANSDUCER ADJUSTMENT

28. Close valve (14).
29. Apply pressure to pressure port (13) until cylinder (11) bottoms in reservoir (9).
30. Mark line on cylinder (11) where cylinder enters housing (15). Use marking pencil (E271).
31. Open valve (14).
32. Close shutoff valve (8).
33. Open valve (7) and fill reservoir (9) until mark on cylinder (11) is **1 inch** from empty position.
34. Connect signal generator (16) to transducer receptacle (17). Pin numbers 1 and 2.
35. Connect voltmeter (18) to transducer receptacle (17). Pin numbers 3 and 4.
36. Apply **5 volts at 450 Hz** to transducer receptacle (17). Then adjust the voltage until the milliammeter reads **10 ma**.

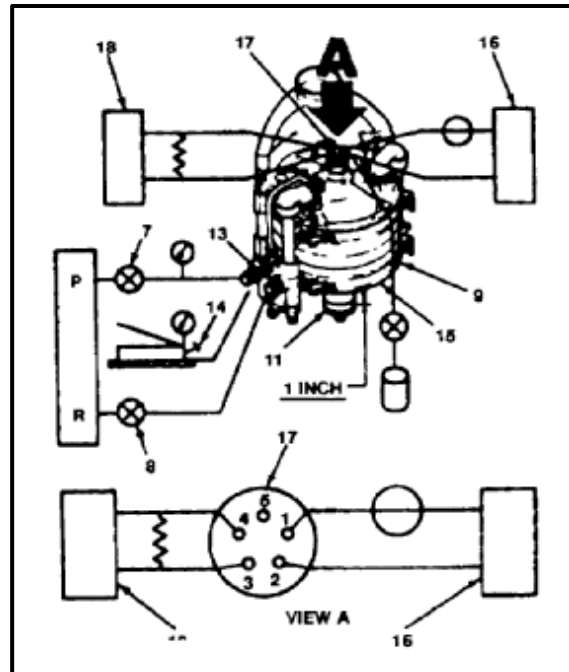

37. Open valve (7) to apply **60 psi** pressure to return port (2) until line on cylinder (11) is **2 inches** from housing (15).
38. Close shutoff valve (7).
39. Check reservoir (9) fluid level. Fluid level shall not change.
40. Remove lockwire from screws (19). Remove two screws from cylinder (11).
41. Turn square end of LVDT core (20) until voltmeter (18) reads **1.653 volts**.
42. Install two screws (19) in cylinder (11). Torque screws to **20 inch-pounds**.
43. Lockwire screws (19). Use lockwire (E231).

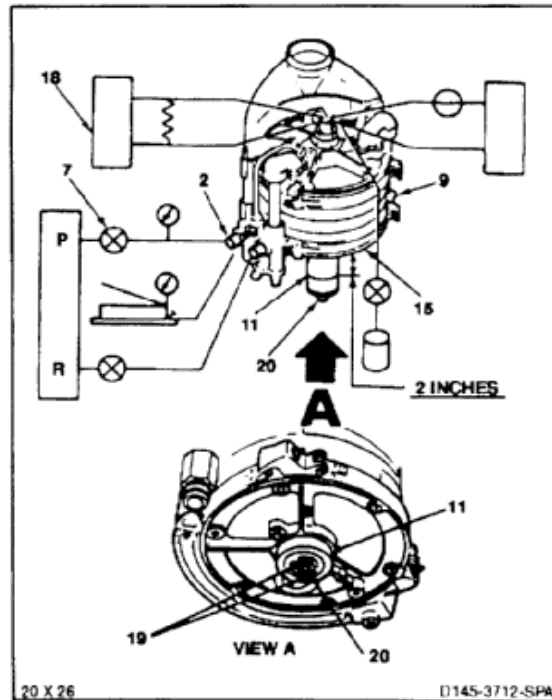

44. Open shutoff valve (8).
45. Close valve (14).
46. Apply pressure to port (13) until pencil line on cylinder (11) aligns with housing (15).
47. Check voltmeter (18) readings. Voltmeter shall read **0 to 0.10 volt** rms.
48. Close shutoff valve (8).
49. Open valve (14).

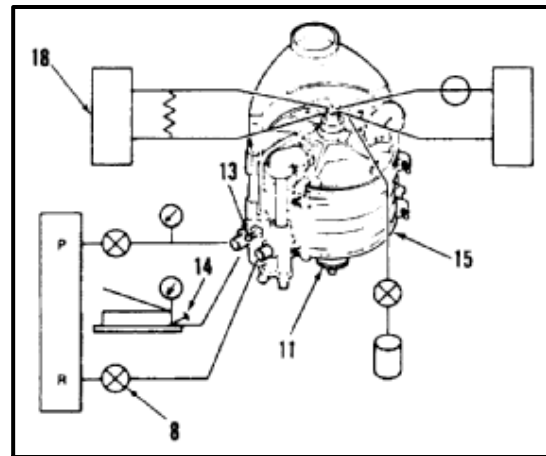

50. Open valve (7) and apply pressure to return port (2) until cylinder (11) is **2.5 inches** from housing (15).
51. Close shutoff valve (7).
52. Check reservoir (9) fluid level. Fluid level shall not change.
53. Check reading on voltmeter (18). Voltmeter shall read **2.026 to 2.106 volts** rms.
54. Open shutoff valve (8) to reduce pressure at return port (2) to **0 psi**.
55. Disconnect voltmeter (18) and signal generator (16) from transducer receptacle (17).

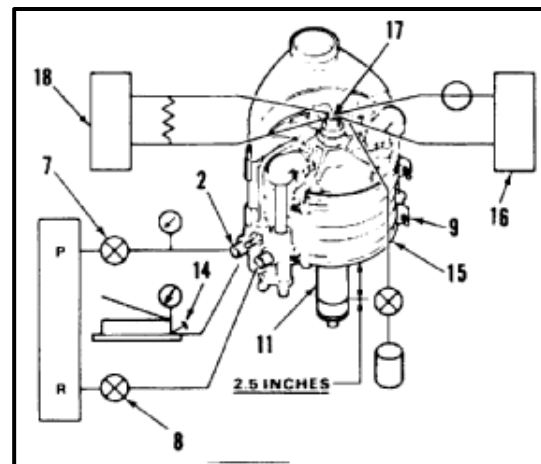

STATIC PRESSURE TEST

56. Remove **0 to 200 psi** gage (21).
57. Connect **0 to 30 psi** gage (22) between valve (7) and return port (2).
58. Close valve (8).
59. Open valve (7) to apply **5 to 20 psi** pressure to return port (2) until reservoir (9) is full. Open shutoff valve (10) and hold bleed relief valve (6) open until reservoir is free of air.
60. Close shutoff valve (7).
61. Open shutoff valve (8) and allow reservoir (9) to empty. When green strip in cylinder (11) starts to enter housing (15), read static pressure on pressure gage (22). Static pressure shall be at least **2 psi**.

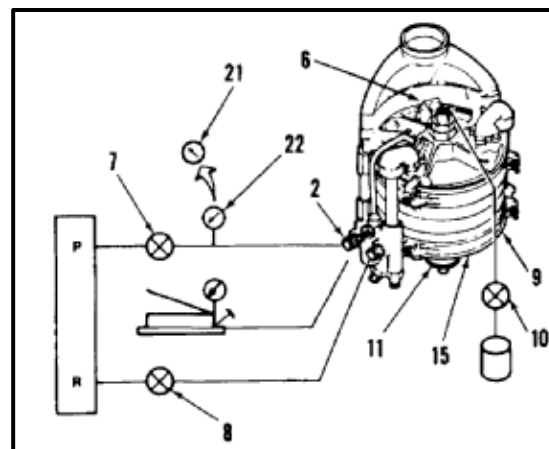

INITIAL SETUP

Applicable Configurations:

All

Tools:

- Aircraft Mechanic's Tool Kit, NSN 5180-00-323-4692
- Open-End Wrench, 1-1/4 Inch
- Open-End Wrench, 1-1/2 Inch

Materials:

Lockwire (E231)

Personnel Required:

- CH-47 Helicopter Repairer
- Inspector

References:

TM 55-1520-240-23P

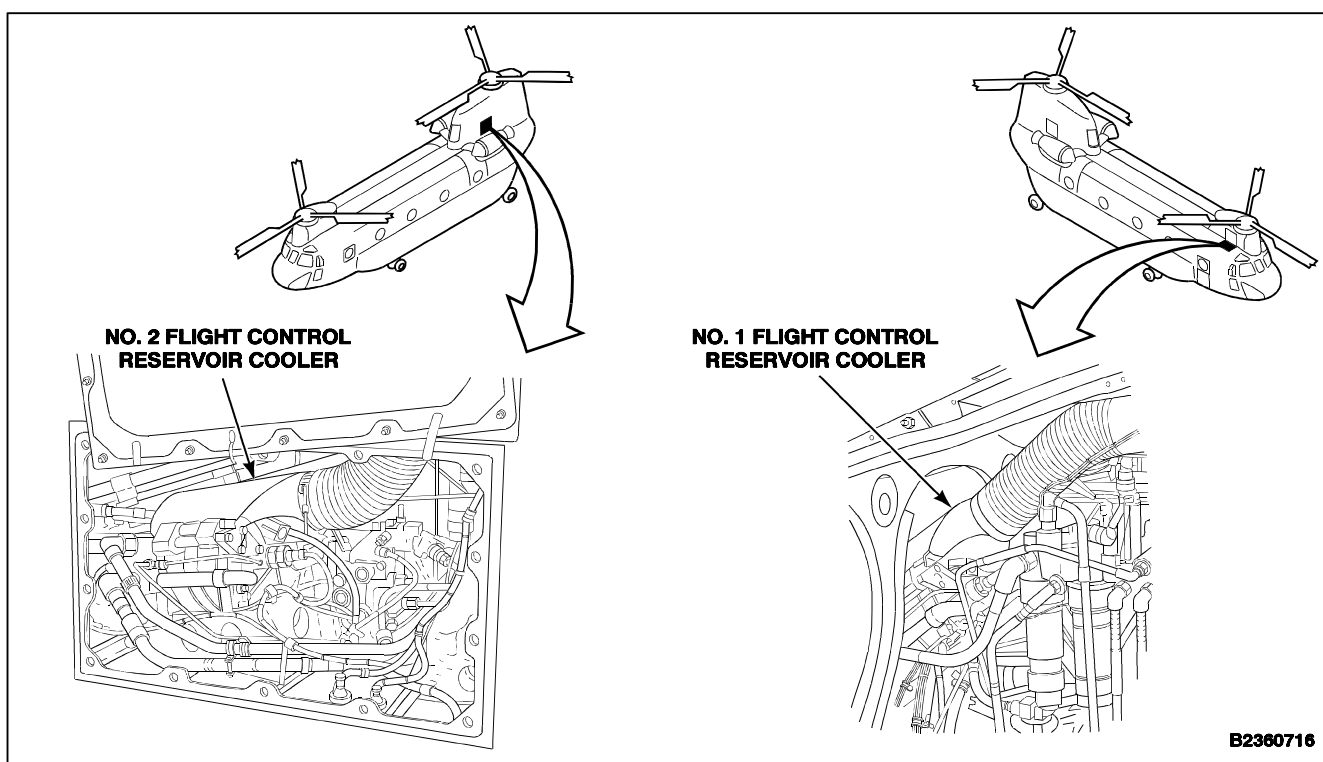

B2360716

NOTE

Procedures are similar for installing the No. 1 or No. 2 flight control reservoir/cooler. No. 1 flight control reservoir/cooler does not require the four washers (1) on studs (2) of bracket (3). Installation of No. 2 reservoir/cooler is shown.

1. Install four washers (1) on stud (2) of bracket (3). Position reservoir/cooler (4) on bracket of support (5). Install four washers and nuts (6) on studs.

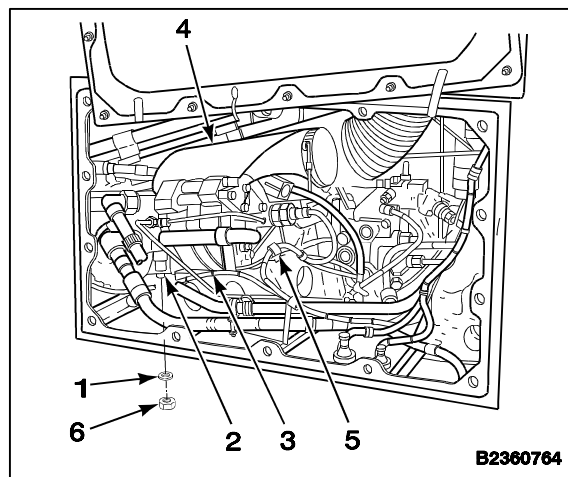

2. Connect electrical plug (7) to bulb (8). Remove tag.
3. Connect electrical plug (9) to switch (10). Remove tag.
4. Connect electrical plug (11) to receptacle (12). Remove tag.
5. Connect tube (13) to SPLY port (14). Remove tag.
6. Connect tube (15) to RTN port (16). Remove tag.
7. Connect tube (17) to port (18). Remove tag.
8. Connect hose (19) to valve (20). Tighten clamp (21).
9. Connect duct (22) to reservoir/cooler (4). Tighten clamp (23).
10. Lockwire clamp (23). Use lockwire (E231).

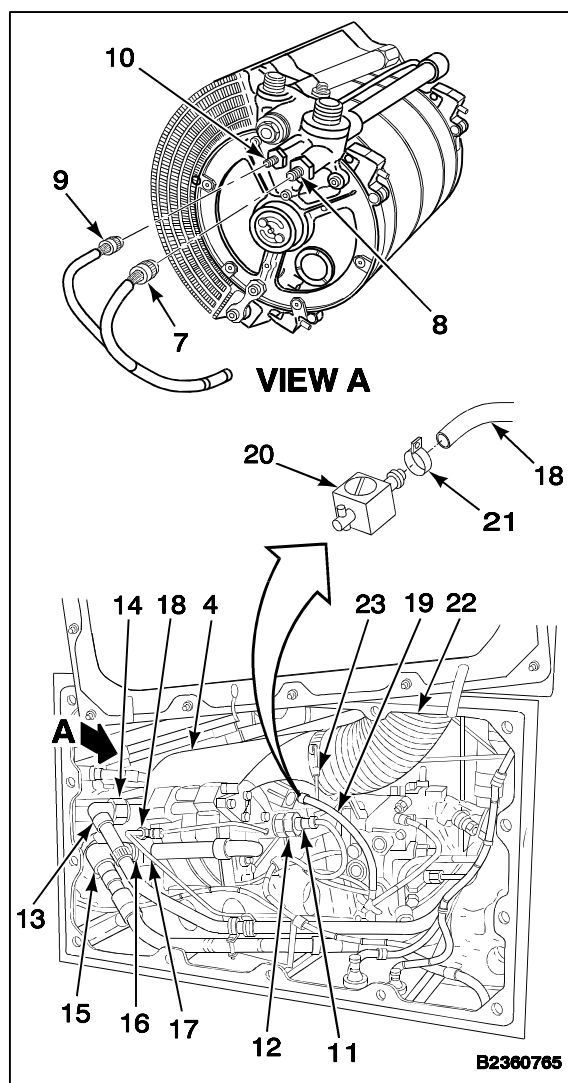

INSPECT

FOLLOW-ON MAINTENANCE:

- Service reservoir/cooler (Task 1-60, 1-61, or 1-62).
- Bleed flight control hydraulic system (Task 7-16).
- Perform operational check of flight control system (TM 55-1520-240-T).
- Close right forward work platform or left pylon access panel (Task 2-2).

END OF TASK

7-118 REMOVE NO. 1 OR NO. 2 FLIGHT CONTROL COOLING FAN

7-118

INITIAL SETUP**Applicable Configurations:**

All

Tools:

Aircraft Mechanic's Tool Kit, NSN 5180-00-323-4692

Materials:

None

Personnel Required:

Medium Helicopter Repairer

Equipment Condition:

Battery Disconnected (Task 1-39)

Electrical Power Off

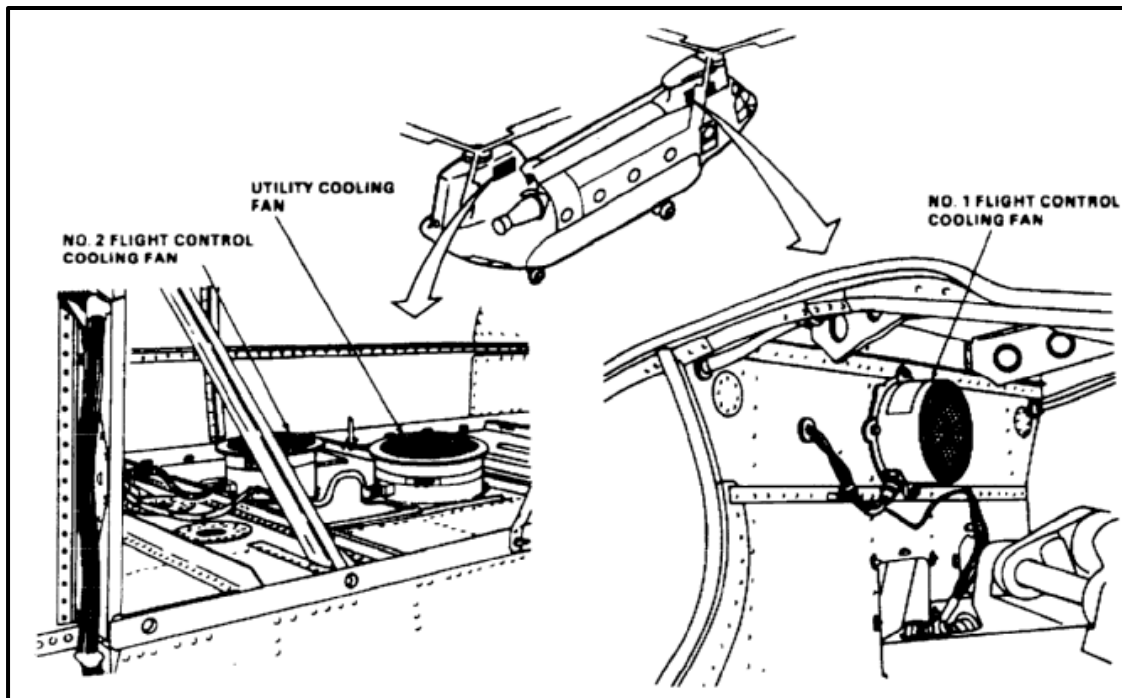
Right Forward Work Platform or Right Pylon Access
Panels Open (Task 2-2)

NOTE

Procedure is similar to remove No. 1 or No. 2 flight control cooling fan. Differences are noted in text. Removal of No. 1 fan is shown here.

1. Loosen screw (1) on clamp (2). Slide clamp over duct (3).
2. Remove duct (3) from fan (4).

3. Disconnect electrical plug (5) from fan (4).
4. Remove four bolts (6) and washers (7).
5. Remove fan (4).

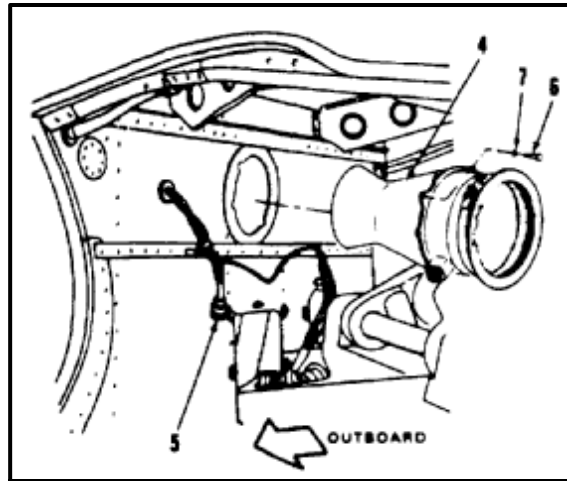
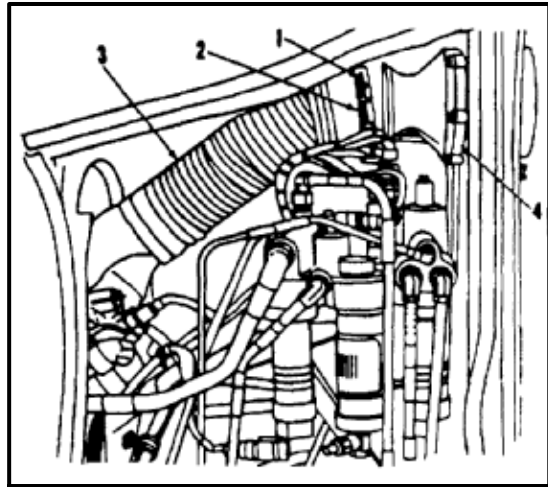
**FOLLOW-ON MAINTENANCE:**

None

Tasks 7-119 thru 7-121 are deleted.

END OF TASK

7-536

INITIAL SETUP

Applicable Configurations:

All

Tools:

Aircraft Mechanic's Tool Kit, NSN 51 80-00-323-4692

Materials:

Lockwire (E231)

Personnel Required:Medium Helicopter Repairer
Inspector**References:**

TM 55-1520-240-23P

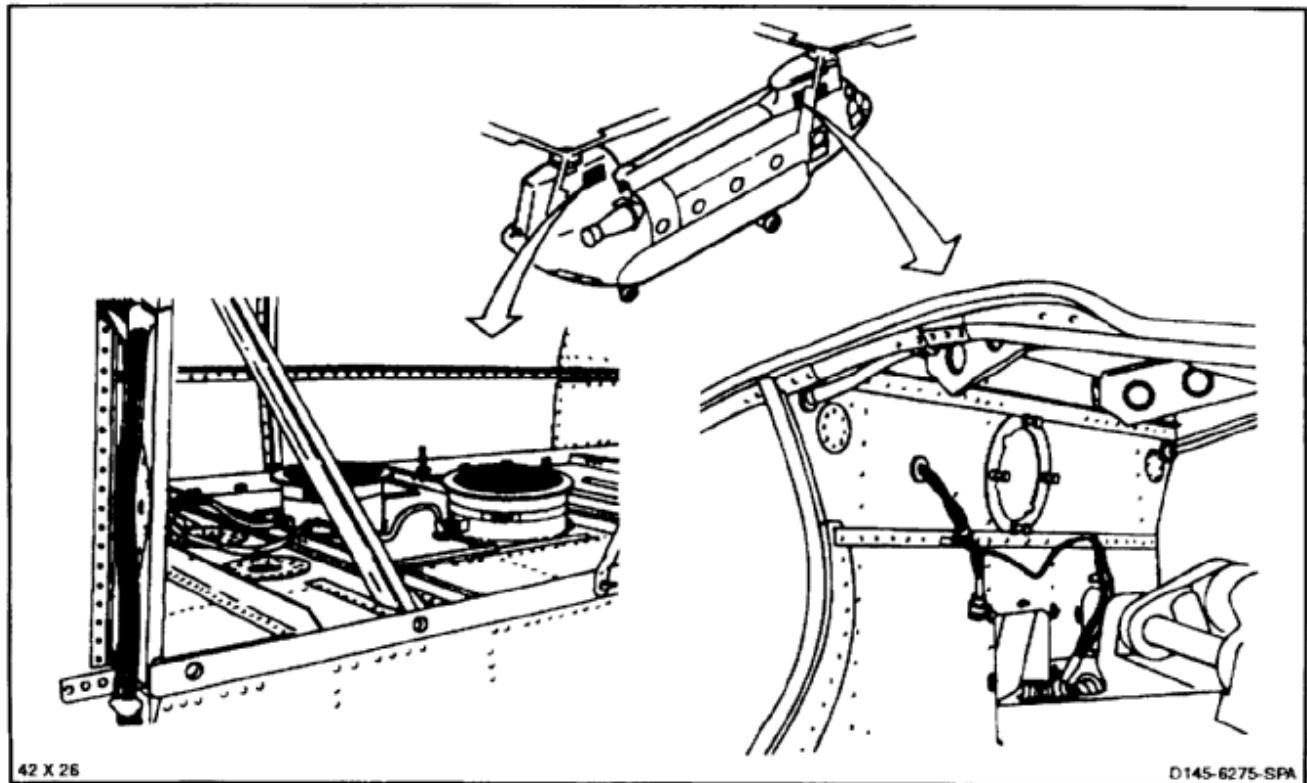

NOTE

Procedure is similar to install No. 1 or No. 2 flight control cooling fan. Installation of No. 1 fan is shown here.

1. Position fan (1) on structure (2), receptacle (3) outboard.
2. Install four bolts (4) and washers (5).
3. Connect electrical plug (6) to receptacle (3).
4. Install duct (7) and clamp (8) on fan (1). Tighten nut (9).
5. Lockwire clamp (8). Use lockwire (E231).

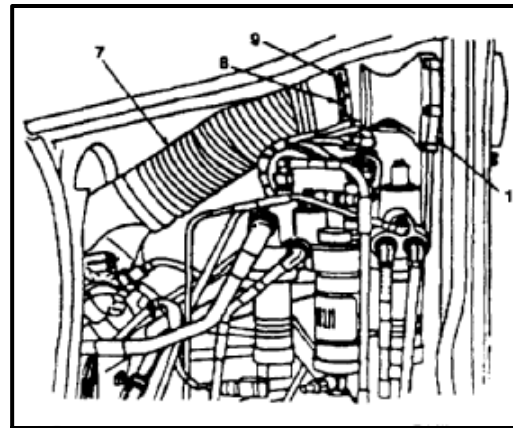
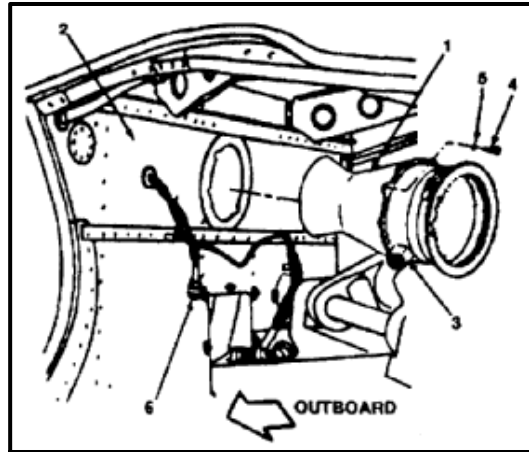
INSPECT**FOLLOW-ON MAINTENANCE:**

- Perform operational check of cooling fan (TM 55-1520-240-T).
- Close right forward work platform or right aft pylon access panels (Task 2-2).

END OF TASK

7-538

INITIAL SETUP**Applicable Configurations:**

All

Tools:

Aircraft Mechanic's Tool Kit, NSN 5180-00-323-4692
 Spacers (APP E-32)

Materials:

Dry Cleaning Solvent (E162)
 Cloths (E120)
 Sealant (E342.1)
 Gloves (E184.1)

Personnel Required:

Medium Helicopter Repairer
 Inspector

References:

TM 55-1520-240-23P
 TM 55-1520-240-T
 Appendix E

Equipment Condition:

Battery Disconnected (Task 1-39)
 Electrical Power Off
 Hydraulic Power Off
 Forward Work Platforms or Aft Access Doors Open
 (Task 2-2)
 Forward or Aft Pitch Links Disconnected (Task 5-97)

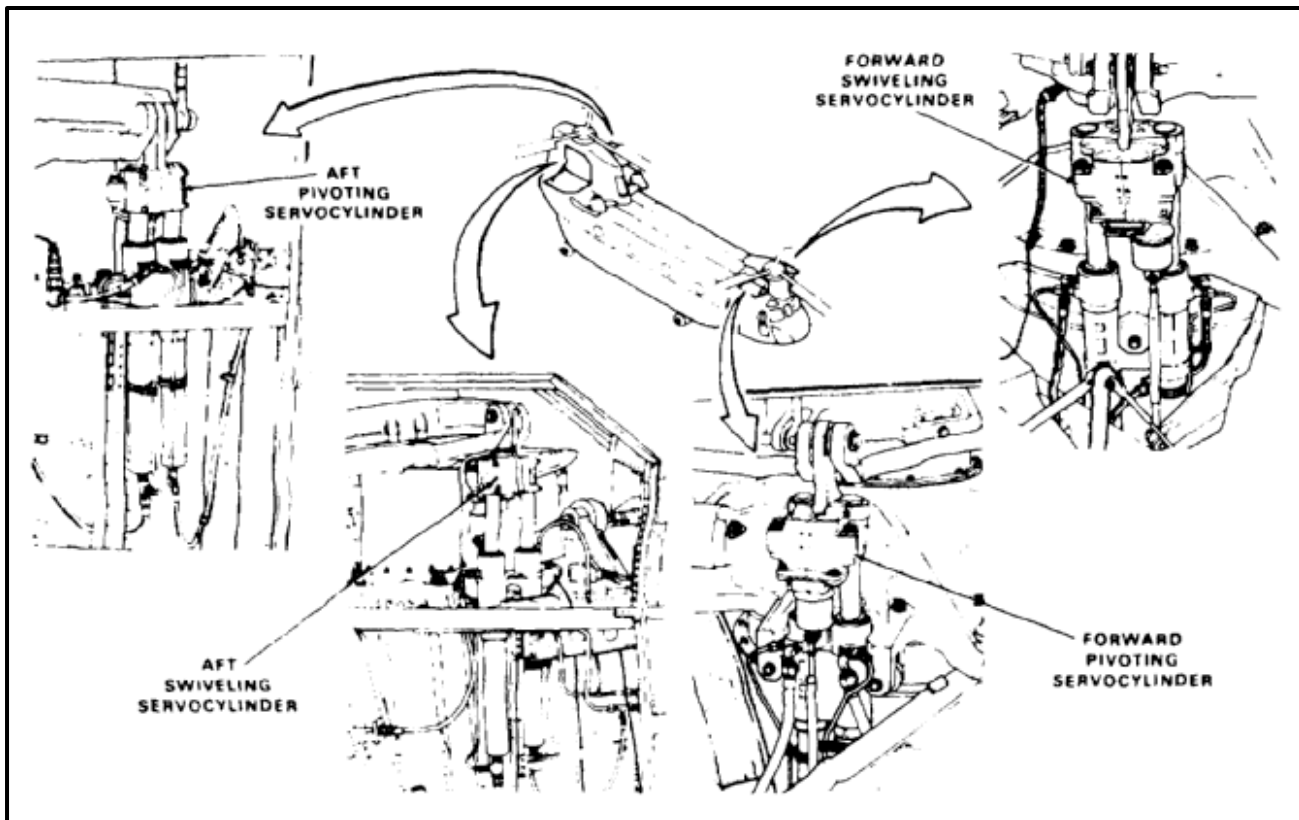

NOTE

Procedure is similar to inspect forward and aft pivoting and swiveling servo cylinders. Forward pivoting servo cylinder is shown here as typical. Differences are noted in text.

1. Check bolt (1), bushing (2), and plates (3) for looseness. There shall be no loose bolt, bushing or plates.
- 1.1. Check that there is a gap between flanges of bushings (2 and 3.1).
2. Check valves (4). If either jam indicator (5) is extended, reset and perform operational check (TM 55-1520-240-T).
3. Check bearing (6) for axial play as follows:
 - a. Move lug (7) towards lug (8).
 - b. Insert spacer (APP E-32) (9) between lug (7) and lug (8). Spacer (9) must fit with no looseness and must not be so tight that it forces lugs apart.
 - c. Move lug (7) towards lug (10).
 - d. Measure distance between lug (8) and spacer (9). Distance (axial play) shall not exceed **0.010 inch**.
4. Check bearing (6) for radial play. Push lugs (8 and 10) down and then up. Feel for play between lug (7) and lugs (8 and 10). There shall be no play between lugs.
5. Check bearings (11) for radial play. Push housing (12) down, then up. Feel for play between lugs (13 and 14) and lug (15). There shall be no play between lugs.
6. Check the following at the forward transmission servo cylinder mounts.
 - a. Check outboard pivoting servo cylinder lugs (13). Bushings (16) shall not be past inboard surface (17) of lug. If bushing is past surface, replace forward transmission.
 - b. Check for a positive gap between outer surface of lug (13) and inside surface of washer (18). If there is no gap present, inspect hardware stack-up on the pivoting servo cylinder or swiveling servo cylinder.

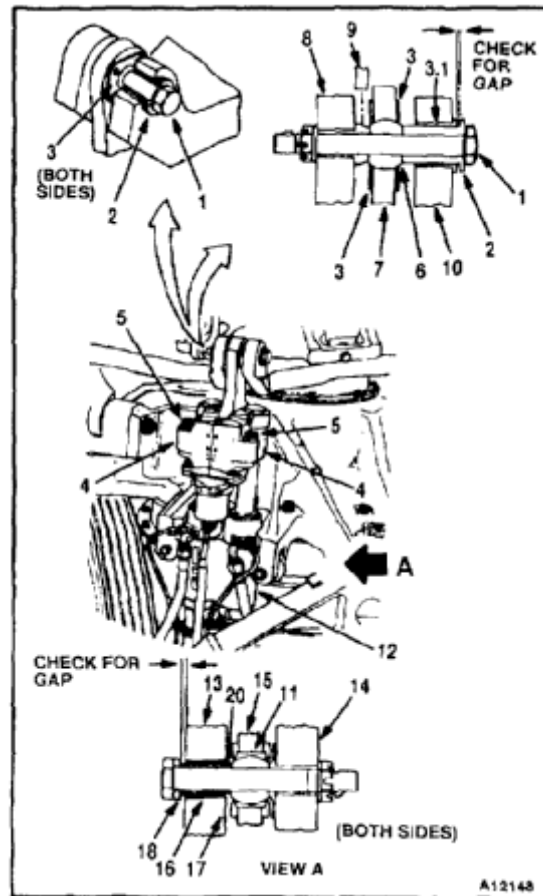

- 7. Check the following at the aft pivoting servocylinder mounts:

NOTE

If no gap is present, the entire hardware stackup should be inspected prior to removal of the servocylinder.

- a. At the forward mount, check for a positive gap between outboard lug (21) and washer (22).
- b. At aft mount, check for a positive gap between inboard lug (23) and washer (24).

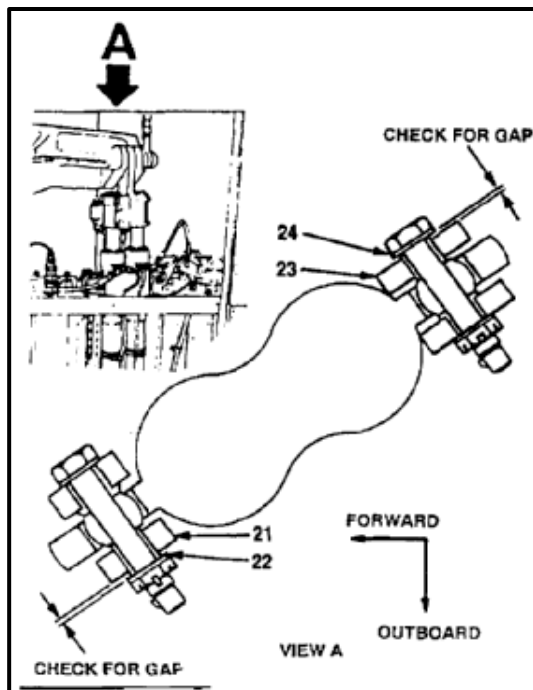

NOTE

If no gap is present, the entire hardware stackup should be inspected prior to removal of the servocylinder.

- 7.1. At the aft swiveling servocylinder mount, check for a positive gap between outboard lug (25) and washer (26).

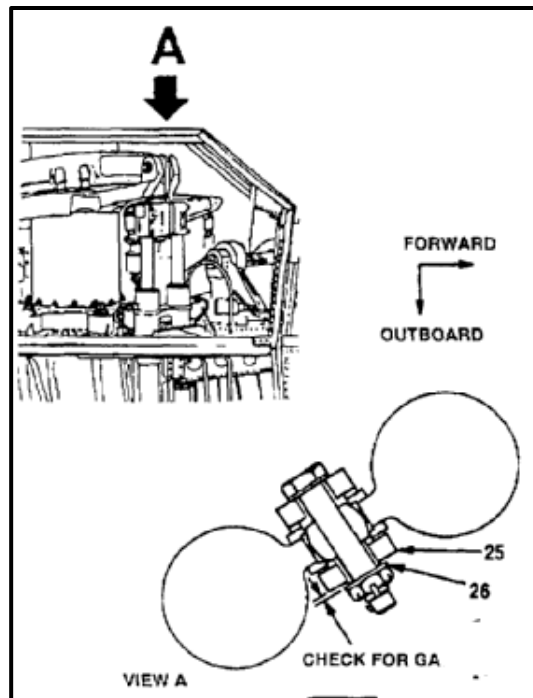

8. Inspect for presence of sealant (18) around retainers (19). If sealant is not present, apply as follows:

WARNING

Dry cleaning solvent (E162) is flammable and toxic, it can irritate skin and cause burns. Use only in well-ventilated area, away from heat and open flame. In case of contact, immediately flush skin or eyes with water for at least **15 minutes**. Get medical attention for eyes.

- a. Clean area to be sealed. Use solvent (E162) and cloths (E120). Remove solvent residue and dry area. Use a dry lint-free cloth (E120). Wear gloves (E184.1).

WARNING

Sealant (E342.1) can irritate skin and cause burns. Avoid contact with skin, eyes, or clothing. In case of contact, immediately flush skin or eyes with water for at least **15 minutes**. Get medical attention for eyes.

- b. Apply a bead of sealant (E342.1) around circumference of retainers (19) at valve housing (4).
- c. Let sealant cure at **70° to 80°F (35° to 41°C)**. Allow sealant to cure for **6 hours**.

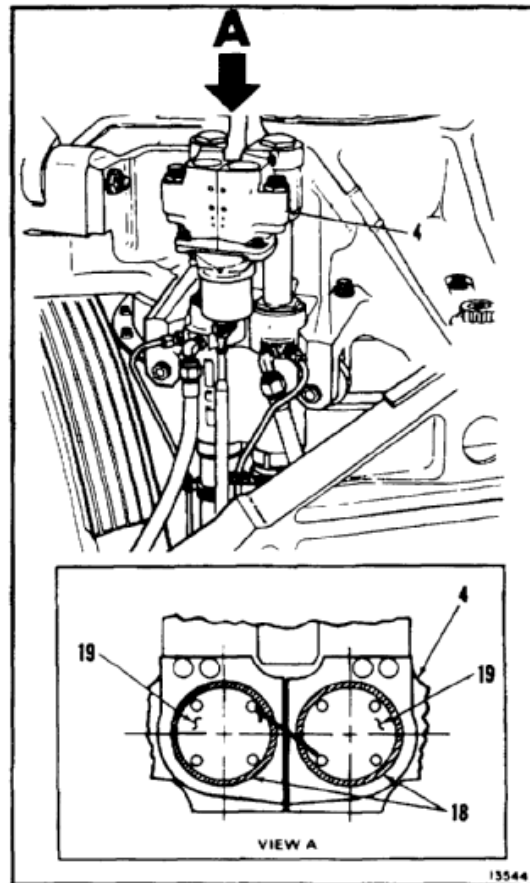
**FOLLOW-ON MAINTENANCE:**

Connect forward or aft pitch links (Task 5-99).
Close forward work platforms or aft access doors (Task 2-2).

END OF TASK

7-542

7-123.1 TEST FORWARD OR AFT, PIVOTING OR SWIVELING SERVOCYLINDER PRESSURE (JAM) INDICATOR (ON AIRCRAFT)

7-123.1

INITIAL SETUP

Applicable Configurations:

All

Tools:

Aircraft Mechanic's Tool Kit, NSN 51 80-00-323-4692

Materials:

None

Personnel Required:

Medium Helicopter Repairer (2)

References:

Tasks 7-123.3 and 7-123.4

Equipment Condition:

Battery Connected (Task 1-39)
 Electrical Power On
 Hydraulic Power On
 AFCS SYSTEM SEL Switch Set to Off
 Servocylinder Safety Blocks (T31) Installed on Servocylinder to be Tested (Task 11-28)

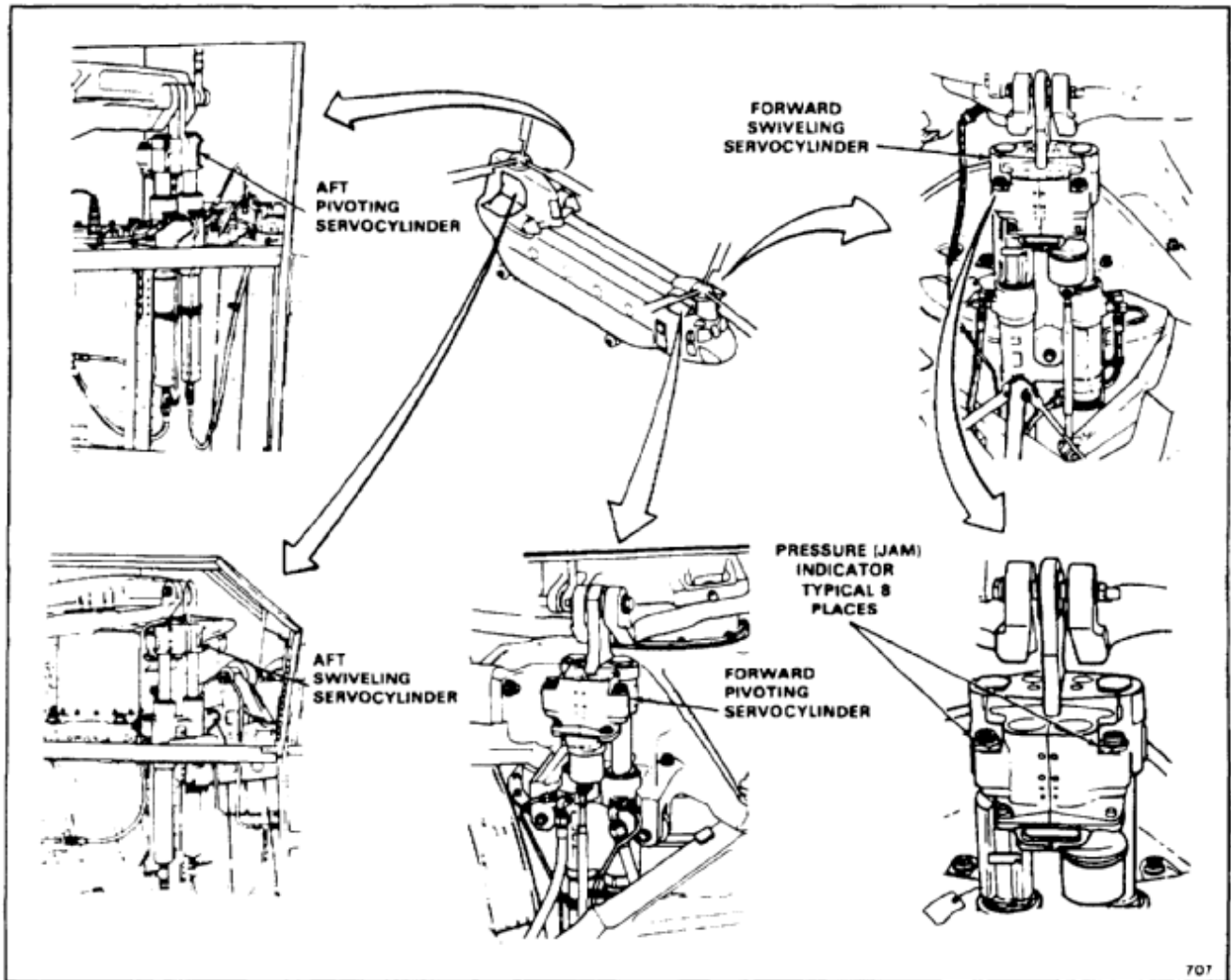

707

NOTE

Procedure to test forward or aft pivoting or swiveling servocylinder jam indicators is same. Test of forward left jam sensor is shown here.

1. Working in cockpit, have helper press copilot's THRUST CONT BRAKE TRIGGER switch (1) and slowly move control (2) down.
2. Working from forward left work platform, check movement of link (3). After actuator (4) contacts block (5), link will move about **0.2 inch** before stopping.
3. Release switch (1).

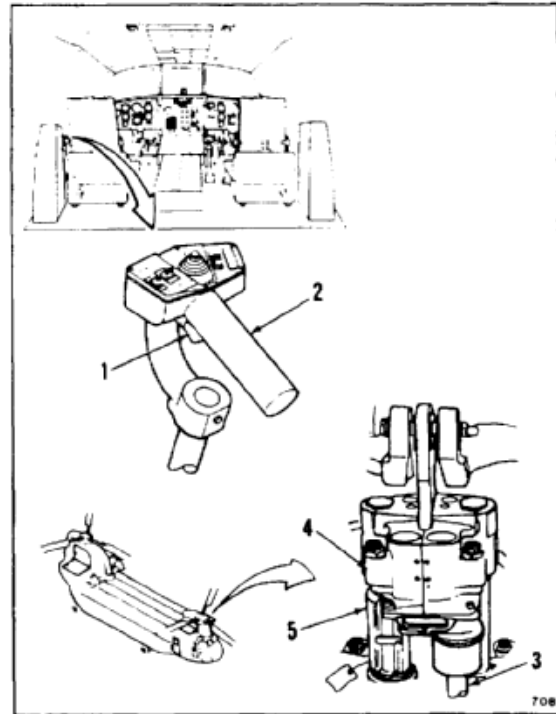

4. Check jam indicator (6). Indicator button (7) shall be extended. If indicator button is not extended, replace jam indicator (Tasks 7-123.3 and 7-123.4).

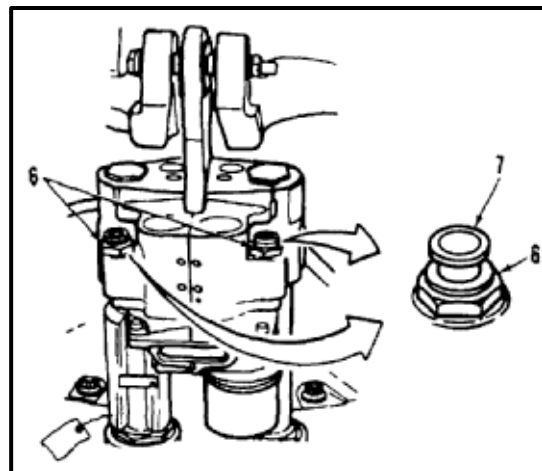

7-123.1 TEST FORWARD OR AFT, PIVOTING OR SWIVELING SERVOCYLINDER PRESSURE (JAM) INDICATOR (ON AIRCRAFT) (Continued)

7-123.1

5. Have helper in cockpit press copilot's THRUST CONT BRAKE TRIGGER switch (1). Pull control (2) up to full up position. Release switch.

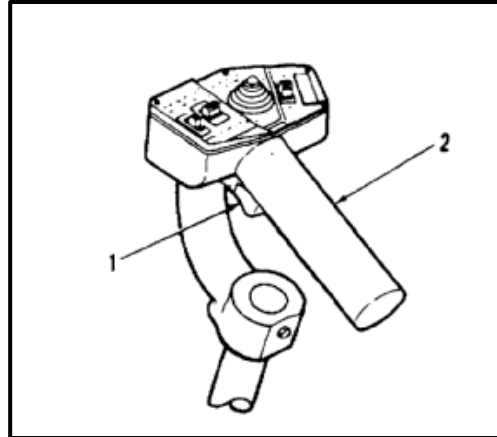

6. Reset indicator button (7). Press button down. Button shall stay down. If button does not stay down, replace jam indicator (Tasks 7-123.3 and 7-123.4).
7. Remove servocylinder safety blocks (Task 11-29).

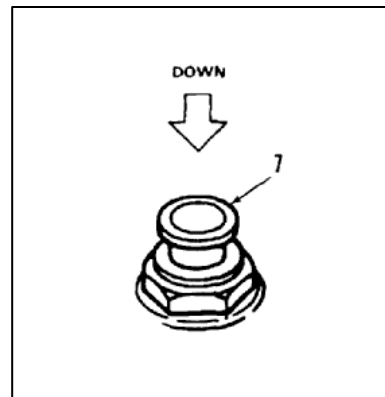
**FOLLOW-ON MAINTENANCE:**

None

END OF TASK

INITIAL SETUP

Applicable Configurations:

All

Tools:

Hydraulic Repairer's Tool Kit, NSN 5180-00-323-4891
 Workstand
 Strap Tool (MS90387)

Materials:

Cloths (E135)
 Gloves (E186)

Parts:

Straps (E375)

Personnel Required.:

Aircraft Pneudraulics Repairer (2)
 Inspector

References:

TM 55-1520-240-23P

Equipment Condition:

Battery Connected (Task 1-39)
 Electrical Power On
 Hydraulic Power On
 Forward and Aft Work Platforms Open (Task 2-2)

General Safety Instructions:

WARNING

Hydraulic fluid (E199) is toxic. It can irritate skin and cause burns. Avoid inhaling. Use only with adequate ventilation. Avoid contact with skin, eyes, or clothing. In case of contact, immediately flush skin or eyes with water for at least **15 minutes**. Get medical attention for eyes.

WARNING

Hydraulic fluid ejected under pressure can cause injury to personnel. Hydraulic fluid sprayed into the air is a fire hazard.

WARNING

Keep head, hands and other body parts clear of moving flight controls. Hydraulic forces can cause severe injury.

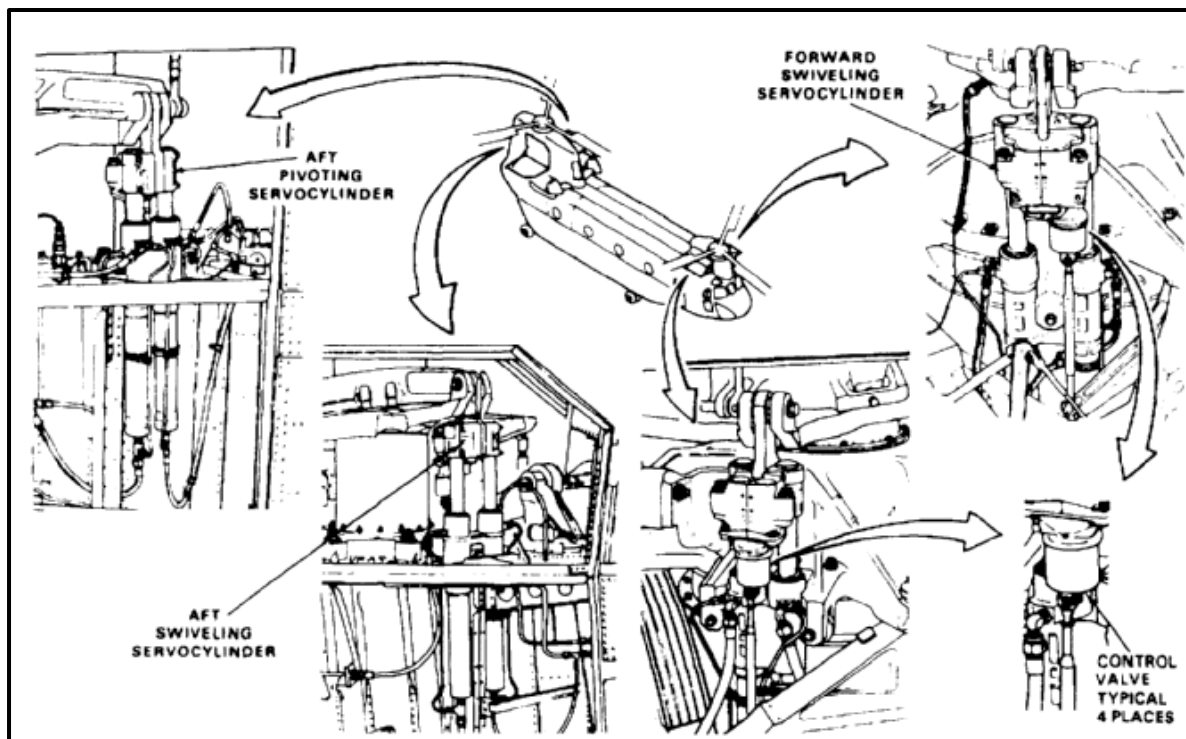

7-123.2 CHECK PIVOTING AND SWIVELING SERVOCYLINDER CONTROL VALVES FOR LEAKAGE (Continued)

7-123.2

NOTE

Procedure is same to check forward or aft, pivoting or swiveling servocylinder control valves. Check of pivoting servocylinder control valve is shown here.

Pressurize both flight control systems to **2600 to 3000 psi**. Allow hydraulic system temperature to stabilize for approximately **20 minutes**.

1. Working from forward right work platform, cut top strap (1) from input shaft housing boot (2). Use diagonal cutting pliers. Remove strap.

NOTE

A combination of allowable static and dynamic leakage may cause hydraulic fluid to leak from 3 drain holes in the boot.

2. Turn top of boot (2) inside-out. Roll down over lower boot strap (3) and input link (4).
3. Check valve shaft (5) and inside surface (6) of boot (2). Clean fluid from shaft and boot. Use cloths (E135) to dry surfaces. Wear gloves (E186).

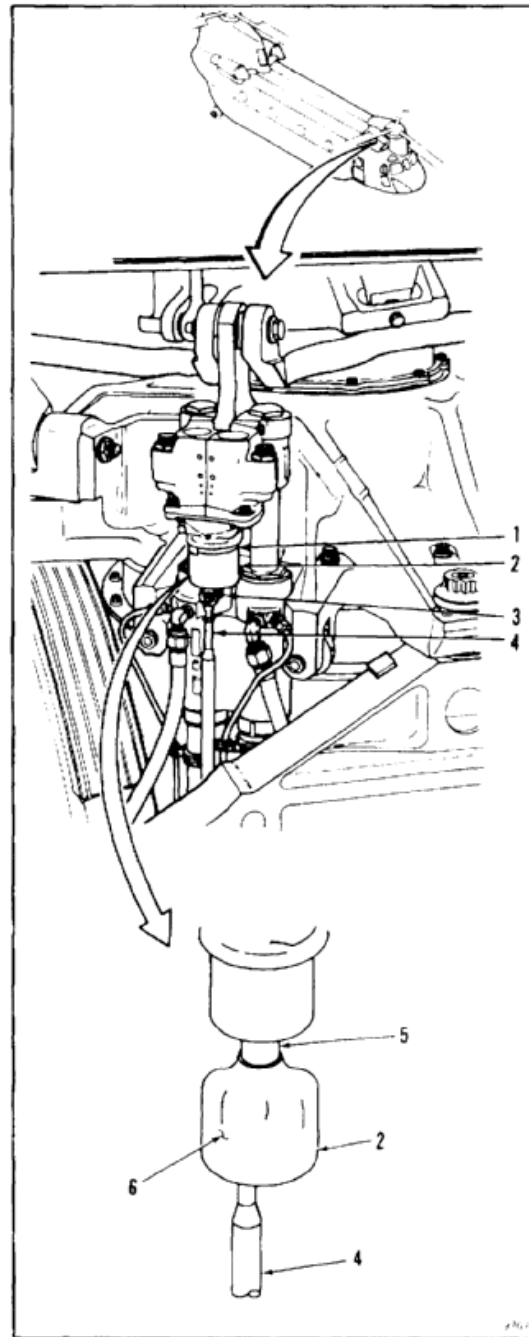

4. Have helper in cockpit press CENTERING DEVICE RELEASE switch (7) on copilot's stick (8). Move stick approximately **2 inches** left then **2 inches** right of neutral stick position at a rate of **20 to 25 cycles per minute**.

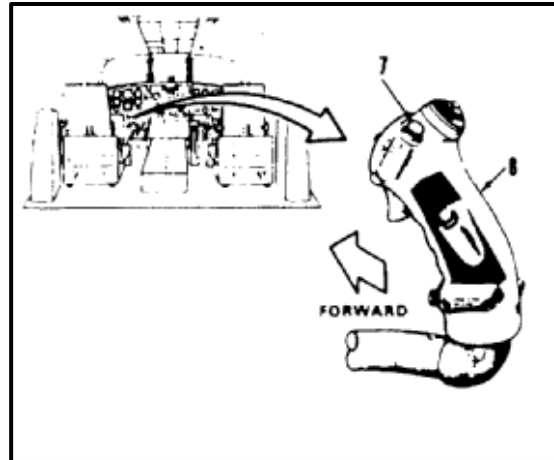

5. When leakage at valve shaft (5) is **1 drop**, check leakage rate for minimum of **6 minutes**. Leakage rate must not be more than **4 drops per 25 cycles**.
6. Stop moving controls when leakage rate is measured.

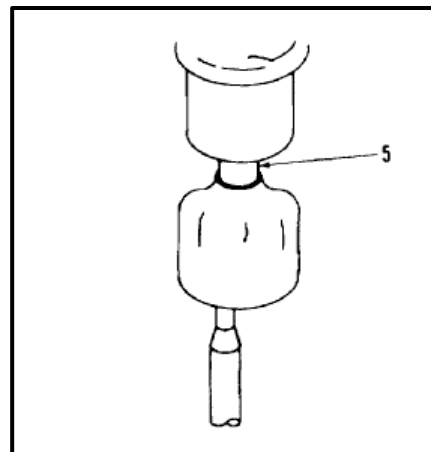

7. Position stick (8) at neutral. Release switch (7).

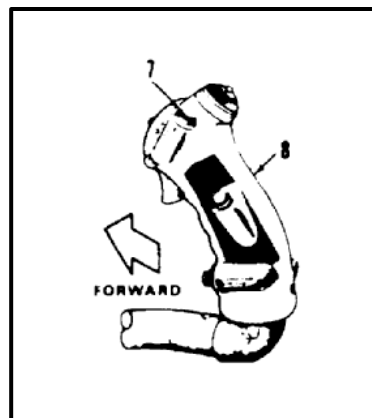

7-123.2 CHECK PIVOTING AND SWIVELING SERVOCYLINDER CONTROL VALVES FOR LEAKAGE (Continued)

7-123.2

8. Check leakage at two retainers (9) and shaft (5). Total leakage of retainers and shaft must not be more than **6 drops in 3 minutes**.
9. Roll boot (2) up over shaft (5). Stretch boot onto housing (10).
10. Install strap (E375) (1) on boot (2) and housing (10). Tighten strap to **15 to 25 pounds** pull force. Use strap tool. Cut off excess strap.
11. Repeat steps 1 thru 10 for forward swiveling servocylinder and aft pivoting and swiveling servocylinders.

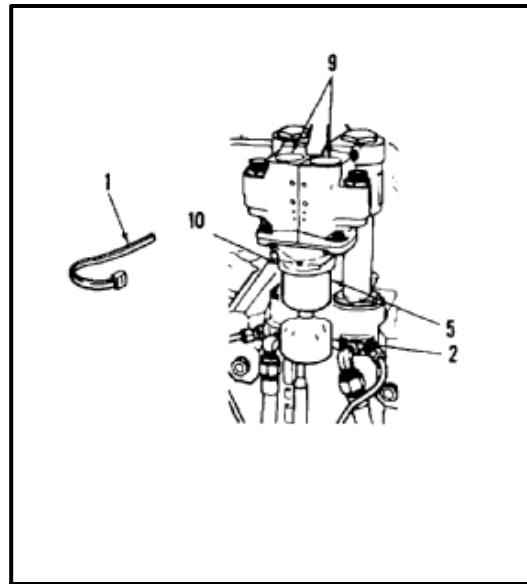
INSPECT**FOLLOW-ON MAINTENANCE:**

- Remove hydraulic power.
- Remove electrical power.
- Disconnect battery (Task 1-39).
- Close forward and aft work platforms (Task 2-2).

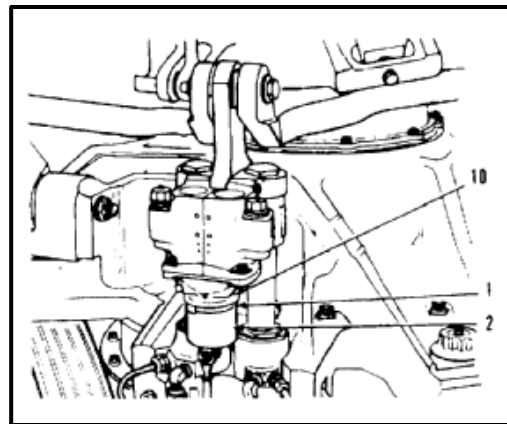

END OF TASK

INITIAL SETUP

*General Safety Instructions:***Applicable Configurations:**

All

Tools:

Aircraft Mechanic's Tool Kit, NSN 5180-00-323-4692

Materials:Cleaning Cloths (E120)
Gloves (E186)**Personnel Required:**

Medium Helicopter Repairer

Equipment Condition:Forward and Aft Work Platforms Open (Task 2-2)
Servocylinder Safety Blocks Installed (Task 11-28)
Battery Disconnected (Task 1-39)
Electrical Power Off
Hydraulic Power Off
Hydraulic System Depressurized (Task 1-63)**WARNING**

Hydraulic fluid (E199) is toxic. It can irritate skin and cause burns. Avoid inhaling. Use only with adequate ventilation. Avoid contact with skin, eyes, or clothing. In case of contact, immediately flush skin or eyes with water for at least **15 minutes**. Get medical attention for eyes.

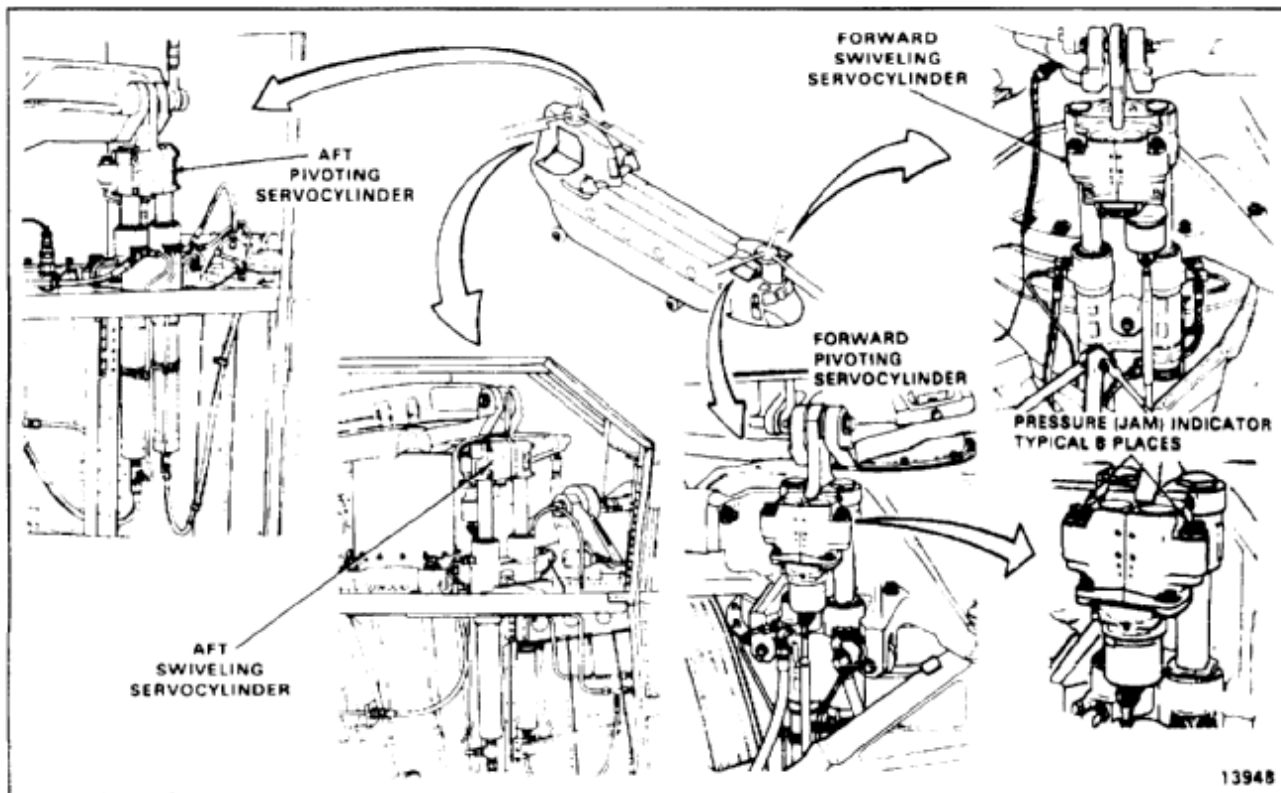

7-123.3 REMOVE PIVOTING OR SWIVELING SERVOCYLINDER PRESSURE (JAM) INDICATOR (Continued)

7-123.3

NOTE

Procedure is same to remove forward or aft pivoting or swiveling servocylinder jam indicators. The forward pivoting servocylinder jam indicator is shown here.

1. Remove lockwire from jam indicator (1).
2. Slowly turn jam indicator (1) counterclockwise. Remove jam indicator, packings (2 and 3), and backup packing retainer (4) from valve housing assembly (5).
3. Use cloths (E120) for spilled hydraulic fluid. Use gloves (E186).

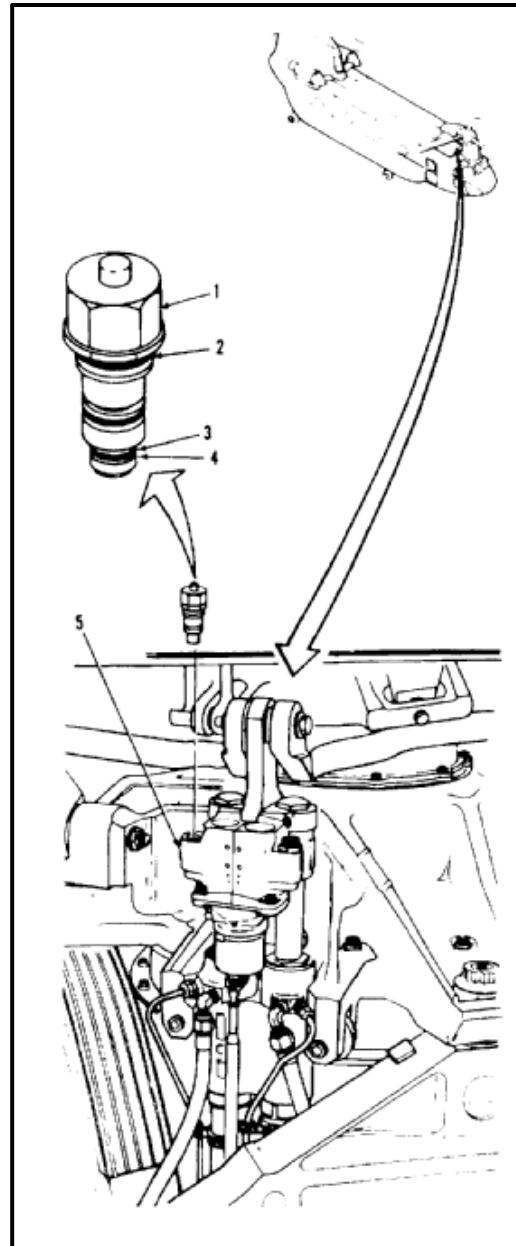
**FOLLOW-ON MAINTENANCE:**

None

END OF TASK

INITIAL SETUP

Applicable Configurations:

All

Tools:

Aircraft Mechanic's Tool Kit, NSN 5180-00-323-4692
Torque Wrench, 0 to 150 Inch-Pounds

Materials:

Lockwire (E230)

Parts:

Packings (2)
Backup Packing Retainer

Personnel Required:

Medium Helicopter Repairer
Inspector

References:

TM 55-1520-240-23P

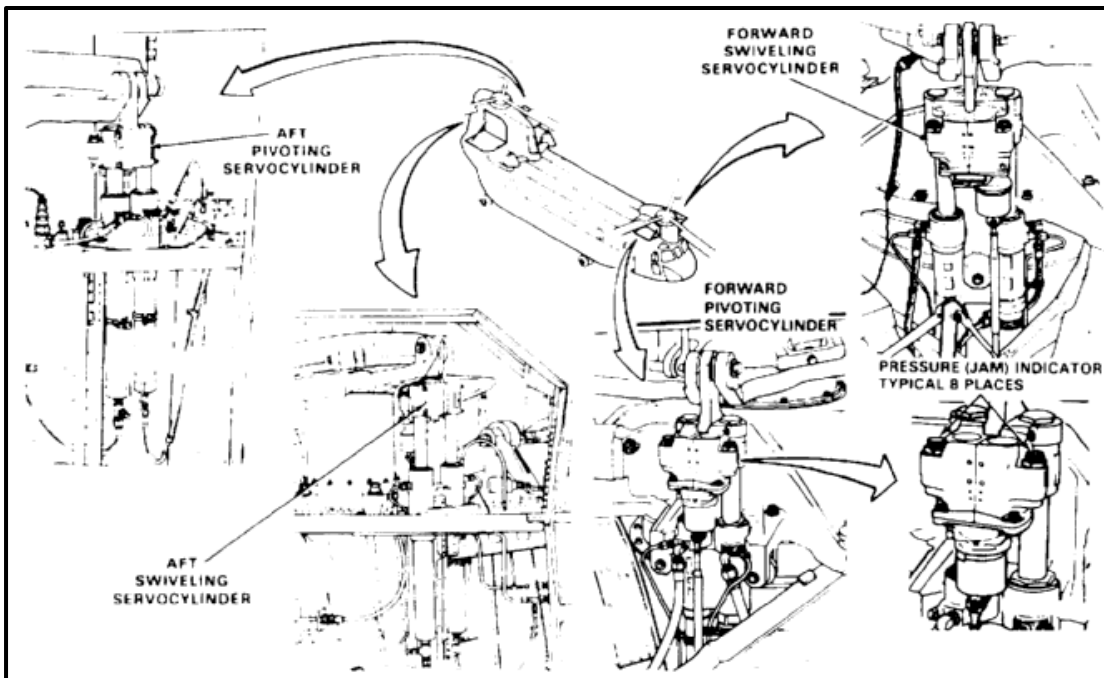

7-123.4 INSTALL PIVOTING OR SWIVELING SERVOCYLINDER PRESSURE (JAM) INDICATOR (Continued)

7-123.4

NOTE

Procedure is same to install forward or aft pivoting or swiveling servocylinder jam indicators. The forward pivoting servocylinder jam indicator is shown here.

1. Install packings (2 and 3) and backup packing retainer (4) on jam indicator (1).

2. Install jam indicator (1) in valve housing assembly (5).
3. Torque jam indicator (1) to **110 inch-pounds**.
4. Lockwire jam indicator (1). Use lockwire (E230).

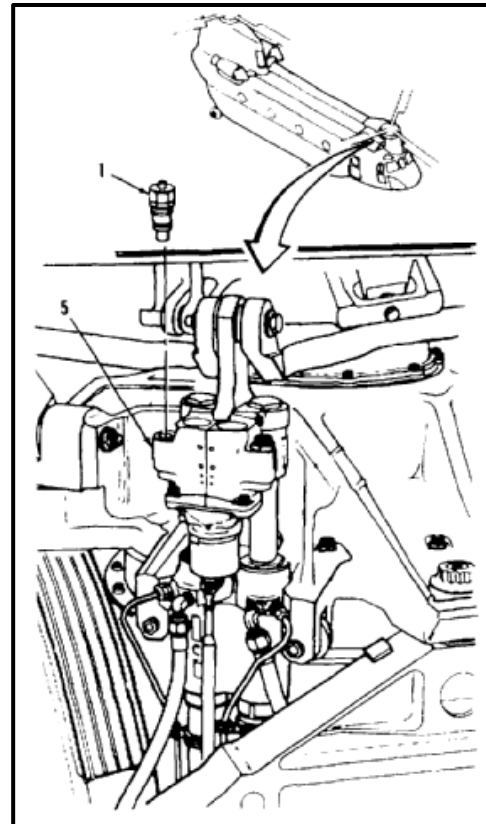
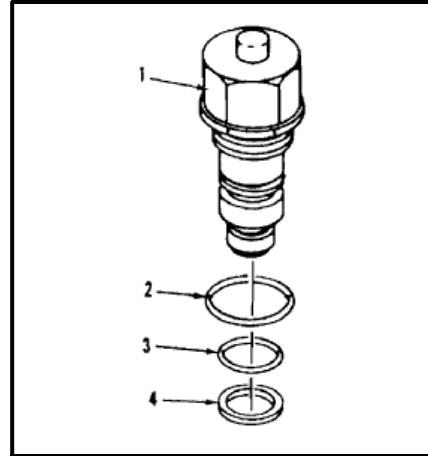
INSPECT**FOLLOW-ON MAINTENANCE:**

Test forward or aft pivoting or swiveling servocylinder pressure (jam) indicator (Task 7-123.1).

END OF TASK

INITIAL SETUP

Applicable Configurations:

All

Tools:

Aircraft Mechanic's Tool Kit, NSN 5180-00-323-4692
 Container, 2 Quart
 Wood Block, 2 Inches X 4 Inches X 12 Inches

Materials:

Cloths (E135)
 Paper Tags (E264)
 Gloves (E186)

Personnel Required:

Medium Helicopter Repairer (2)

Equipment Condition:

Battery Disconnected (Task 1-39)
 Electrical Power Off
 Hydraulic Power Off
 Forward Pitch Links Disconnected (Task 5-97)
 Right Forward Work Platform Open (Task 2-2)
 Forward Transmission Drip Pan Removed (Task 2-3)

General Safety Instructions:**WARNING**

Hydraulic fluid (E199) is toxic. It can irritate skin and cause burns. Avoid inhaling. Use only with adequate ventilation. Avoid contact with skin, eyes, or clothing. In case of contact, immediately flush skin or eyes with water for at least **15 minutes**. Get medical attention for eyes.

WARNING

Hydraulic fluid ejected under pressure can cause injury to personnel. Hydraulic fluid sprayed into the air is a fire hazard.

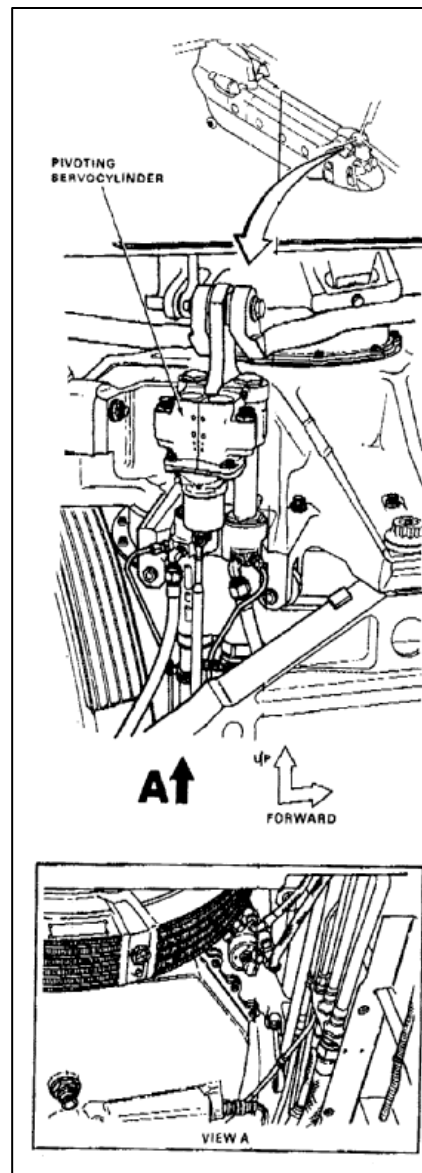

1. Have helper in passageway, tag and disconnect two hoses (1) from tees (2). Use container and cloths (E135) for spilled fluid. Use gloves (E186).

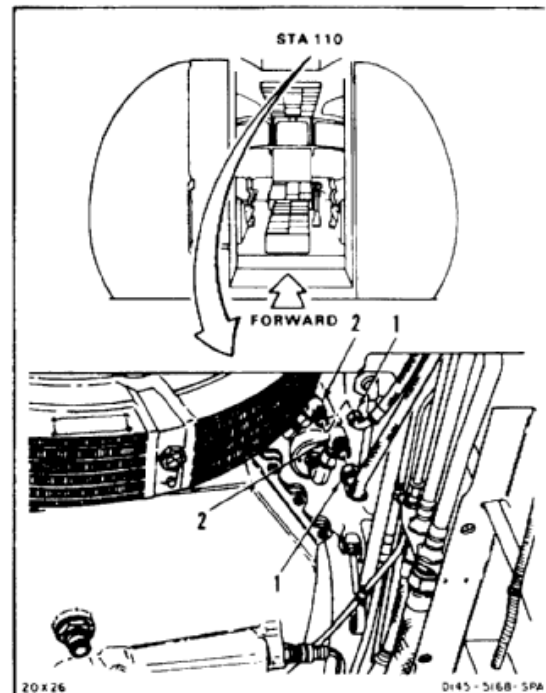

2. From work platform, tag and disconnect two hoses (3) from servocylinder (4). Use container and cloths (E135) for spilled fluid.

WARNING

Support weight of swashplate lug prior to removing upper mount bolt from servocylinder. Damage to mounts and/or servocylinder may result if item is dropped.

CAUTION

Positive retention bolts are installed in the upper controls. They have a pawl which prevents nut or bolt removal unless the pawl is depressed.

3. Remove cotter pin (5), nut (6), washer (7), and bolt (8) from lug (9).

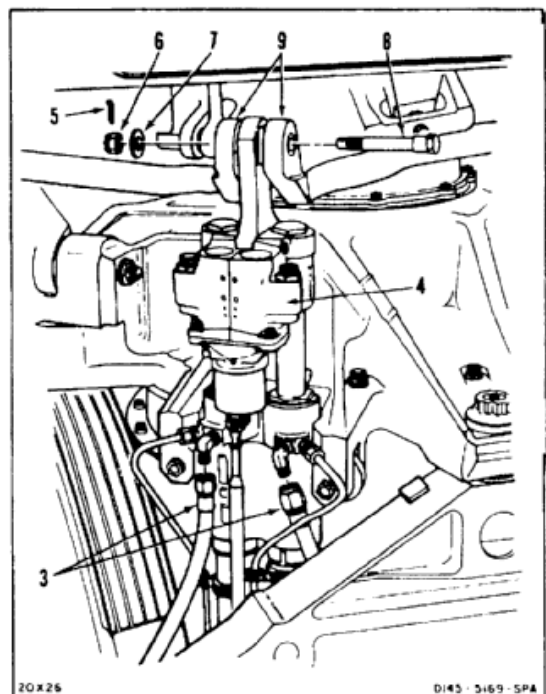

4. Tilt swashplate (10) for clearance. Support swashplate with wood block (11).
5. Remove cotter pin (12), nut (13), two washers (14), and bolt (15) from link (16). Move link away from servocylinder (4).
- 5.1. Remove inner bushing (15.1) and outer bushing (15.2) from servocylinder (4).

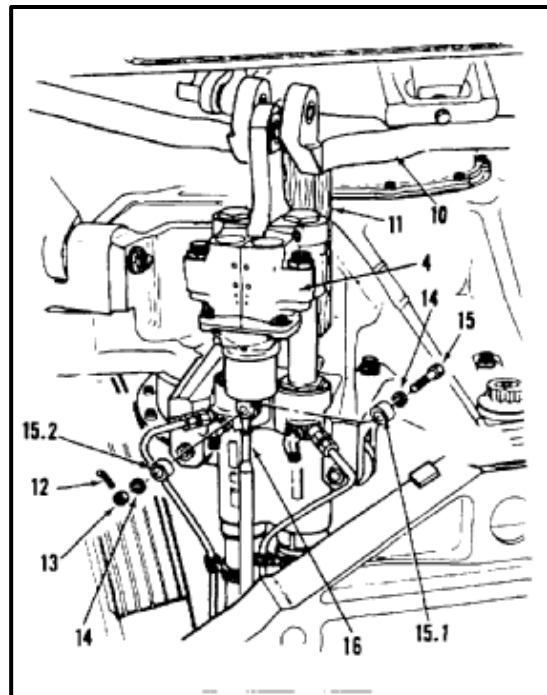

NOTE

Two washers may have been installed under nut to allow for cotter pin installation.

REMOVE SERVOCYLINDER WITHOUT 50

6. Have helper support servocylinder (4). Remove cotter pin (17), nut (18), washer (19), slip bushing (19.1), washer (19.2), countersunk washer (19.3), and bolt (20) from each servocylinder mount (21). Go to step 7.

REMOVE SERVOCYLINDER WITH 50

- 6.1. Have helper support servocylinder (4). Remove cotter pin (17), nut (18) two washers (19), and bolt (20) from each servocylinder mount (21). Go to step 7.
7. Remove servocylinder (4).

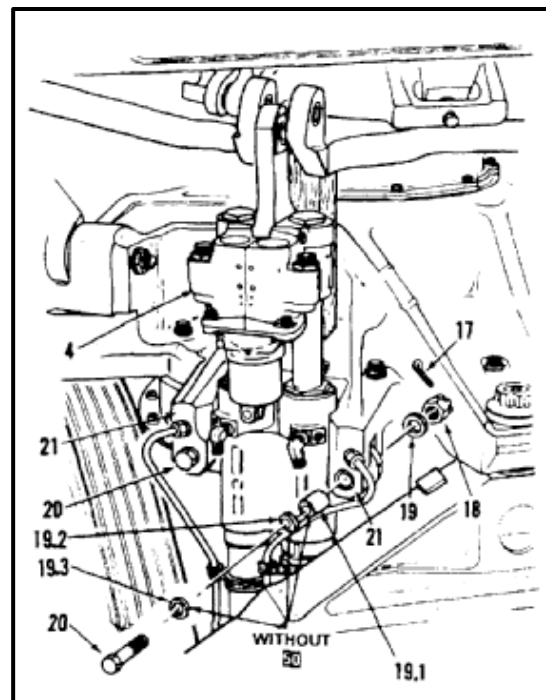

7-124 REMOVE FORWARD PIVOTING SERVOCYLINDER (Continued)

7-124

8. Remove two screws (22), washers (23), and nuts (24) from clamps (25).
9. Remove two valves (28) and packings (29) from servocylinder (4).
10. Tag and disconnect two tubes (26) from servocylinder (4) and tees (27). Remove tubes.
11. Remove two clamps (25).
12. Remove two elbows (30), and packings (31).
13. Remove two elbows (32), tees (27), and packings (33).

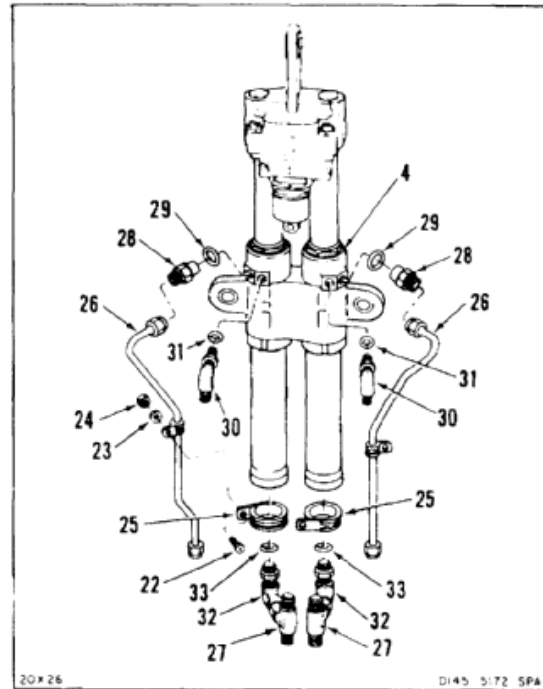
**FOLLOW-ON MAINTENANCE:**

None

END OF TASK

INITIAL SETUP

Applicable Configurations:

All

Tools:

Aircraft Mechanic's Tool Kit, NSN 5180-00-323-4692
 Container, 2 Quart
 Wood Block, 2 Inches X 4 Inches X 12 Inches

Materials:

Cloths (E135)
 Paper Tags (E264)
 Gloves (E184.1)

Personnel Required:

Medium Helicopter Repairer (2)

Equipment Condition:

Battery Disconnected (Task 1-39)
 Electrical Power Off
 Hydraulic Power Off
 Aft Pitch Links Disconnected (Task 5-97)
 Aft Left Work Platform Open (Task 2-2)

General Safety Instructions:**WARNING**

Hydraulic fluid (E199) is toxic. It can irritate skin and cause burns. Avoid inhaling. Use only with adequate ventilation. Avoid contact with skin, eyes, or clothing. In case of contact, immediately flush skin or eyes with water for at least **15 minutes**. Get medical attention for eyes.

WARNING

Hydraulic fluid ejected under pressure can cause injury to personnel. Hydraulic fluid sprayed into the air is a fire hazard.

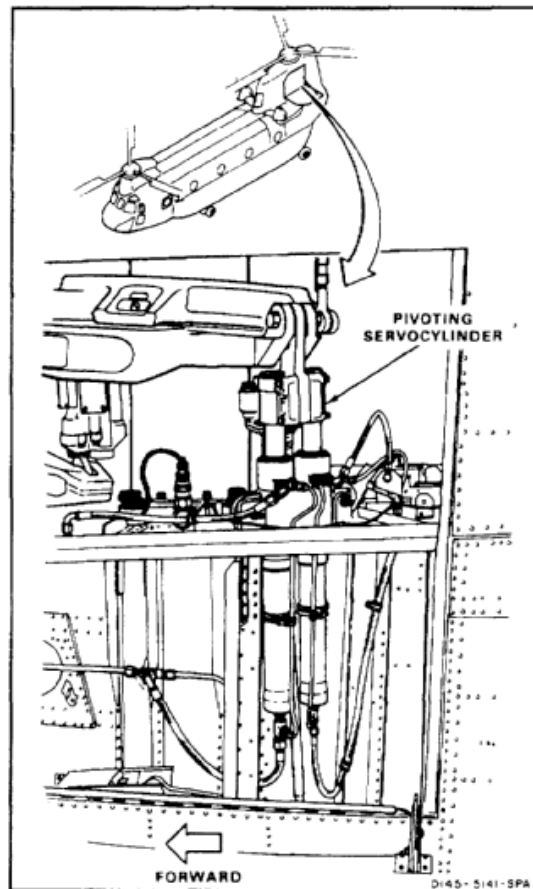

1. Tag and disconnect two hoses (1) from tees (2). Use container and cloths (E135) for spilled fluid. Wear gloves (E184.1).
2. Tag and disconnect two hoses (3) from servocylinder (4). Use container and cloths (E135) for spilled fluid. Wear gloves (E184.1).

CAUTION

Positive retention bolts are installed in the upper controls. They have a pawl which prevents nut or bolt removal unless the pawl is depressed.

3. Remove cotter pin (5), nut (6), washer (7), and bolt (8) from lugs (9).

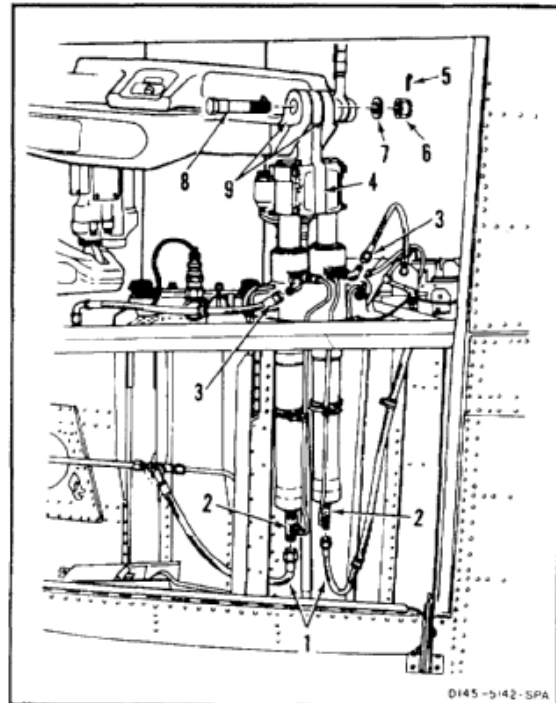

4. Tilt swashplate (10) for clearance. Support swashplate with wood block (11).
5. Remove cotter pin (12), nut (13), two washers (14), and bolt (15) from link (16).



Positive retention bolts are installed in the upper controls. They have a pawl which prevents nut or bolt removal unless the pawl is depressed.

- 5.1. Remove inner bushing (34) and outer bushing (35).
6. Have helper support servocylinder (4). Remove cotter pin (17), nut (18), three or four washers (19), and bolt (20) from each servocylinder mount (21).
7. Remove servocylinder (4).

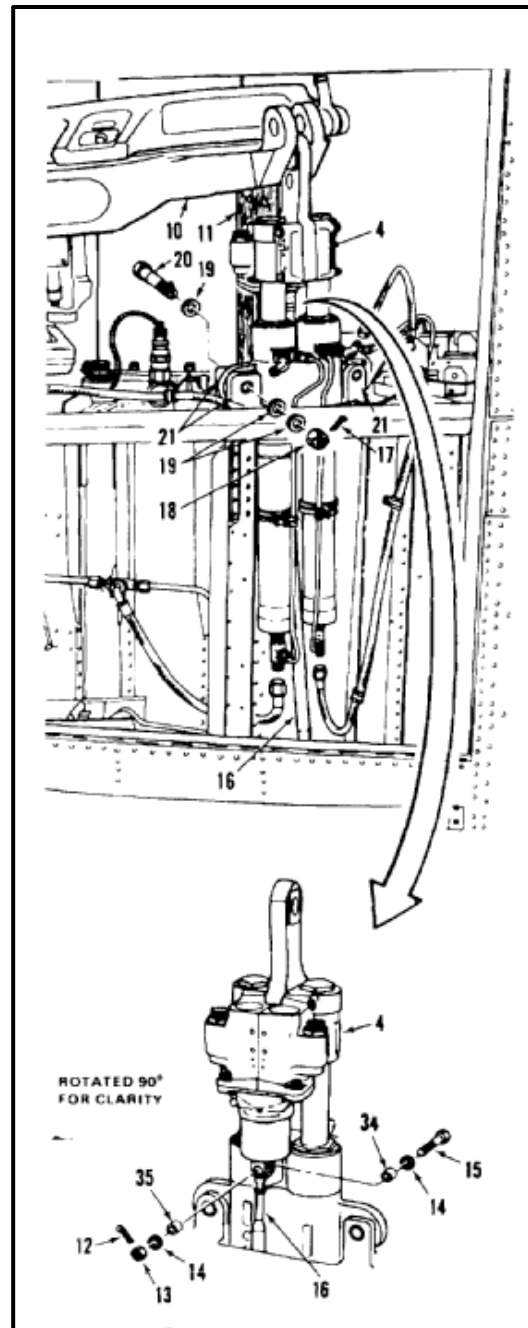

7-125 REMOVE AFT PIVOTING SERVOCYLINDER (Continued)

7-125

8. Remove two screws (22), four washers (23), two spacers (24), and two nuts (25) from four clamps (26 and 27).
9. Remove two clamps (26).
10. Tag and remove two tubes (28).

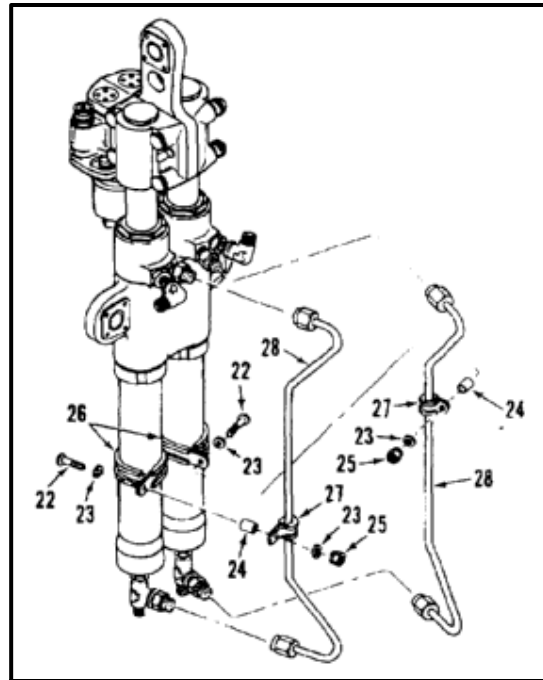

11. Remove two elbows (29) and packings (30).
12. Remove two tees (2) and packings (31).
13. Remove two nipples (32) and packings (33).

FOLLOW-ON MAINTENANCE:

None

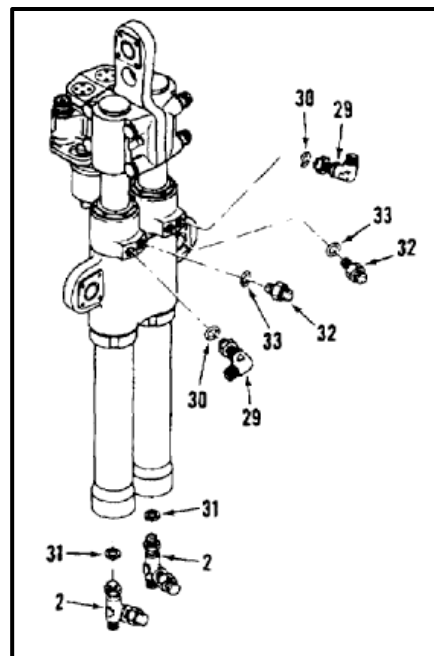

END OF TASK

INITIAL SETUP

Applicable Configurations:

All

Tools:

Aircraft Mechanic's Tool Kit, NSN 5180-00-323-4692
 Container, 2 Quart
 Wood Block, 2 Inches X 4 Inches X 12 Inches

Materials:

Cloths (E135)
 Paper Tags (E264)
 Gloves (E186)

Personnel Required:

Medium Helicopter Repairer (2)

Equipment Condition:

Battery Disconnected (Task 1-39)
 Electrical Power Off
 Hydraulic Power Off
 Forward Pitch Links Disconnected (Task 5-97)
 Left Forward Work Platform Open (Task 2-2)
 Forward Transmission Drip Pan Removed (Task 2-3)

General Safety Instructions:**WARNING**

Hydraulic fluid (E199) is toxic. It can irritate skin and cause burns. Avoid inhaling. Use only with adequate ventilation. Avoid contact with skin, eyes, or clothing. In case of contact, immediately flush skin or eyes with water for at least **15 minutes**. Get medical attention for eyes.

WARNING

Hydraulic fluid ejected under pressure can cause injury to personnel. Hydraulic fluid sprayed into the air is a fire hazard.

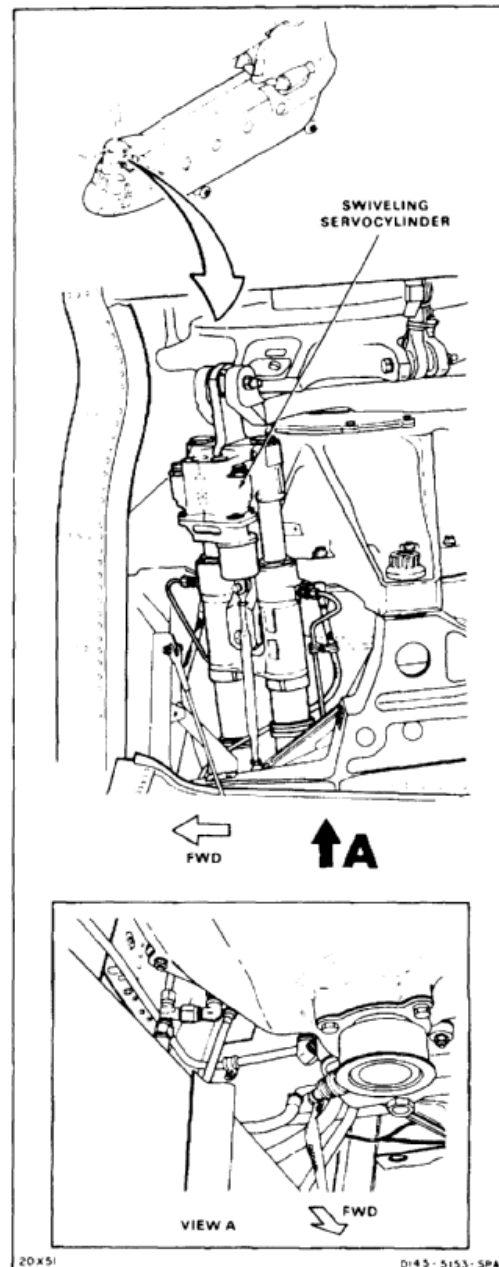

1. Have helper, in passageway, tag and disconnect two hoses (1) from tees (2). Use container and cloths (E135) for spilled fluid. Use gloves (E186).

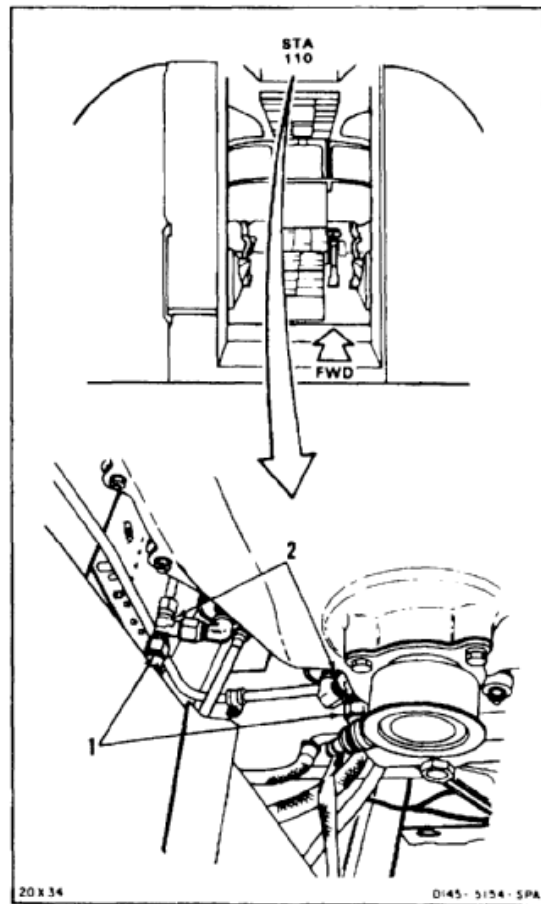

2. From work platform, remove screw (3), washer (4), and nut (5) from clamp (6).
3. Tag and disconnect two hoses (7) from servocylinder (8). Use container and cloths (E135) for spilled fluid.
4. Remove cotter pin (9), nut (10), washer (11), and bolt (12) from lugs (13).

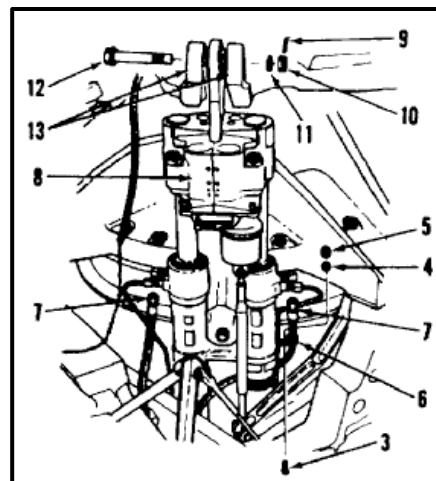

5. Tilt swashplate (14) for clearance. Support swashplate with wood block (15).
6. Remove cotter pin (16), nut (17), three or four washers (18), and bolt (19) from link (20). Move link away from servocylinder (8).
- 6.1. Remove inner bushing (19.1) and outer bushing (19.2) from servocylinder (8).

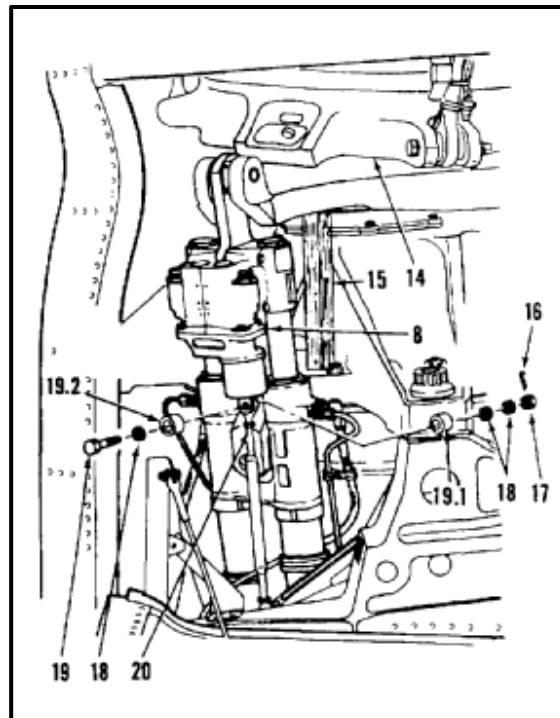

NOTE

Two washers may have been installed under nut to allow for cotter pin installation.

REMOVE SERVOCYLINDER WITHOUT 50

7. Have helper support cylinder (8). Remove cotter pin (21), nut (22), washer (23), slip bushing (23.1), washer (23.2), countersunk washer (23.3), and bolt (24) from servocylinder mount (25). Go to step 8.

REMOVE SERVOCYLINDER WITH 50

- 7.1. Have helper support cylinder (8). Remove cotter pin (21), nut (22), two washers (23), and bolt (24) from servocylinder mount (25). Go to step 8.
8. Remove servocylinder (8).

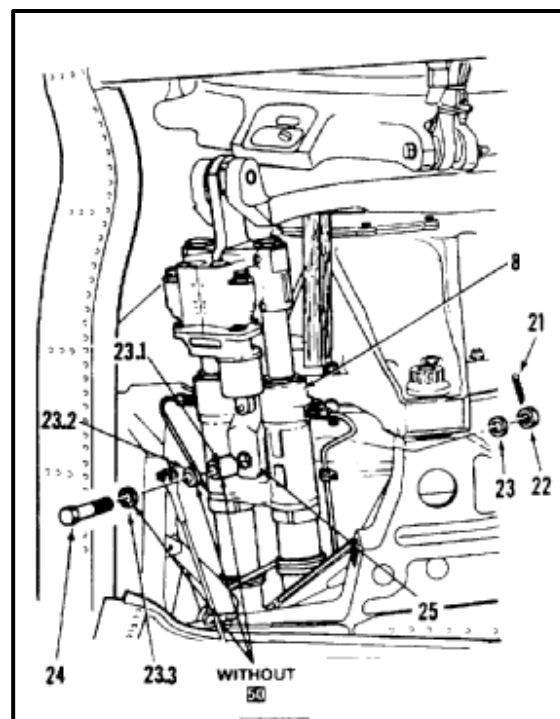

7-126 REMOVE FORWARD SWIVELING SERVOCYLINDER (Continued)

7-126

9. Remove two screws (26), washers (27), and nuts (28) from clamps (29).
10. Tag and remove two tubes (30).
11. Remove two clamps (29).
12. Remove two elbows (31) and packings (32).
13. Remove two valves (33) and packings (34).
14. Remove two elbows (35), tees (36), and packings (37).

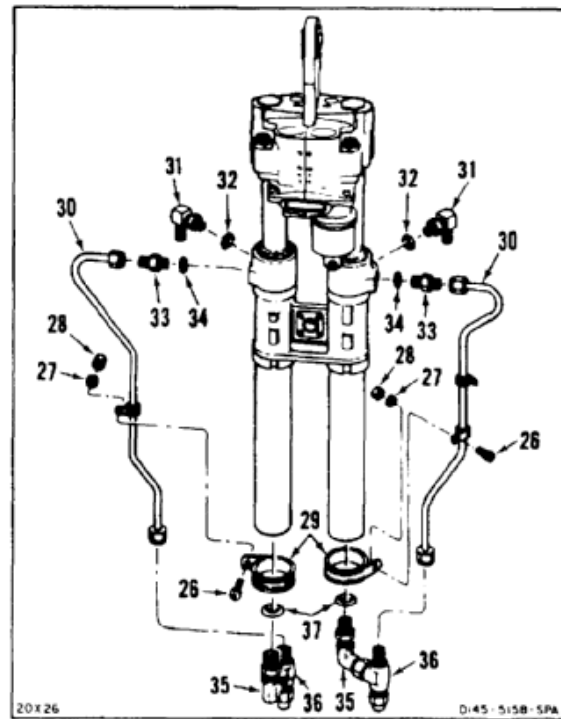
**FOLLOW-ON MAINTENANCE:**

None

END OF TASK

INITIAL SETUP

Applicable Configurations:

All

Tools:

Aircraft Mechanic's Tool Kit, NSN 5180-00-323-4692
Container, 2 Quart
Wood Block, 2 Inches X 4 Inches X 12 Inches

Materials:

Cloths (E135)
Paper Tags (E264)
Gloves (E186)

Personnel Required:

Medium Helicopter Repairer (2)

Equipment Condition:

Battery Disconnected (Task 1-39)
Electrical Power Off
Hydraulic Power Off
Aft Pitch Links Disconnected (Task 5-97)
Right Aft Work Platform Open (Task 2-2)

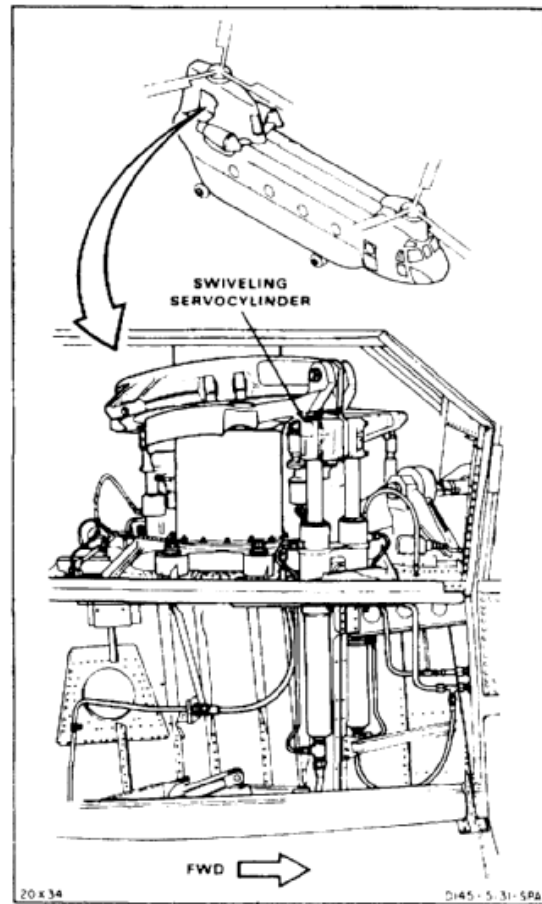

7-127 REMOVE AFT SWIVELING SERVOCYLINDER (Continued)

7-127

1. Tag and disconnect two hoses (1) from tees (2). Use container and cloths (E135) for spilled fluid. Use gloves (E186).
2. Tag and disconnect two hoses (3) from servocylinder (4). Use container and cloths (E135) for spilled fluid.
3. Remove cotter pin (5), nut (6), washer (7), and bolt (8) from lug (9).

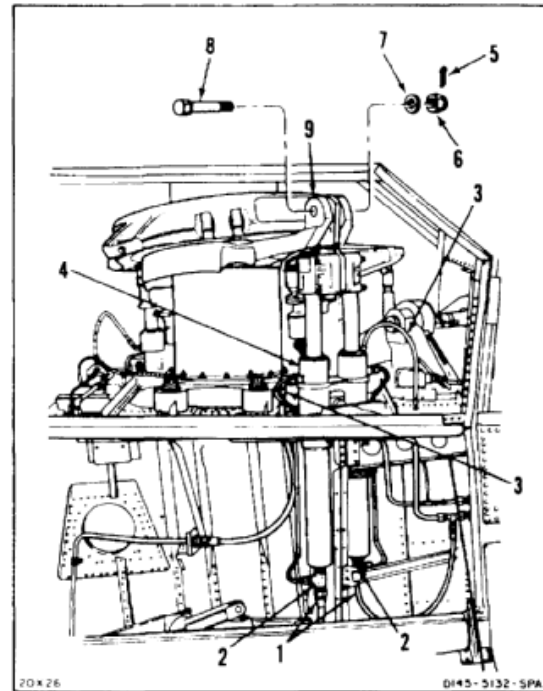

4. Tilt swashplate (10) for clearance. Support swashplate with wood block (11).
5. Remove cotter pin (12), nut (13), two washers (14) and bolt (15) from link (16).

NOTE

Two washers may have been installed under nut to allow for cotter pin installation.

6. Have helper support servocylinder (4). Remove cotter pin (17), nut (18), three or four washers (19) and bolt (20) from mount (21).
7. Remove servocylinder (4).

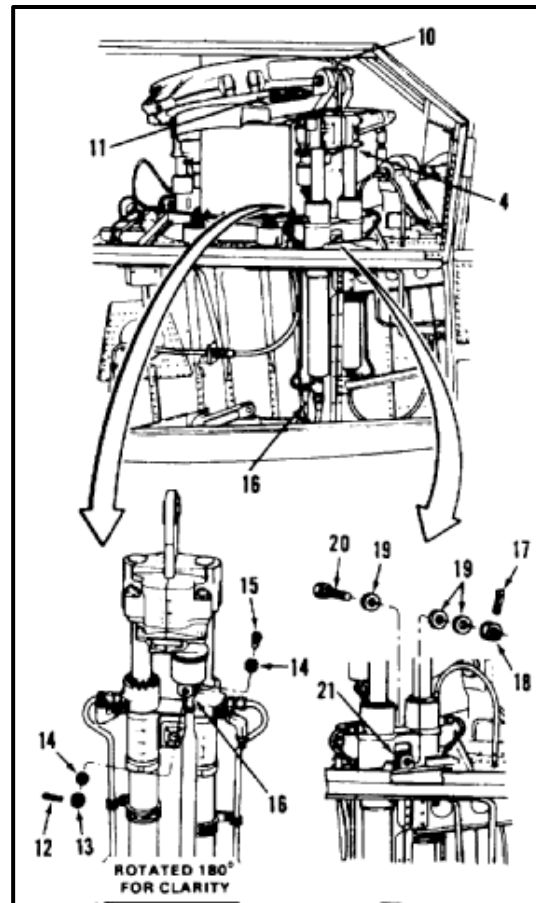

7-127 REMOVE AFT SWIVELING SERVOCYLINDER (Continued)

7-127

8. Remove two screws (22), washers (23), and nuts (24) from clamps (25).
9. Tag and remove two tubes (26).
10. Remove two clamps (25).
11. Remove two elbows (27) and packings (28).
12. Remove two valves (29) and packings (30).
13. Remove two tees (31) and packings (32).

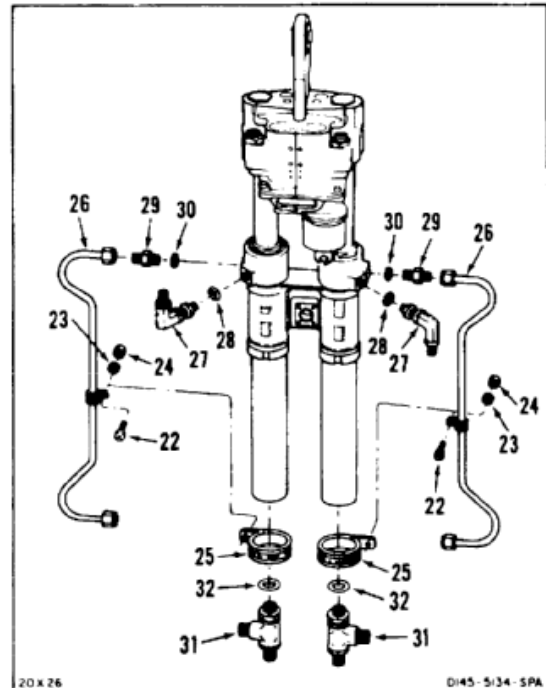
**FOLLOW-ON MAINTENANCE:**

None

END OF TASK

INITIAL SETUP

Applicable Configurations:

All

Tools:

Hydraulic Repairer's Tool Kit, NSN 5180-00-323-4891

Dial Indicator, NSN 5210-00-277-8840

Vise

Fixture (APP E-32)

Materials:

None

Personnel Required:

Aircraft Pneudraulics Repairer

Inspector

References:

Appendix E

Equipment Condition:

Off Helicopter Task

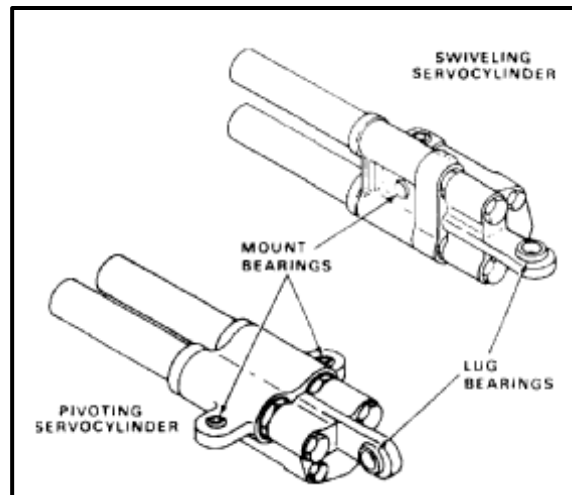

**INSPECT PIVOTING AND SWIVELING
SERVOCYLINDER LUG BEARING FOR AXIAL AND
RADIAL PLAY**

NOTE

Procedure is same to inspect pivoting or swiveling servocylinder lug bearing for axial and radial play. Swiveling servocylinder is shown here.

1. Install bolt (1), two spacers (2), plate (3), and nut (4) in bearing (5).
2. Clamp head of bolt (1) in vise (6).
3. Mount indicator (7) on plate (3). Position point (8) against lug (9), parallel to plate (3).
4. Push servocylinder (10) toward bolt (1), then pull away. Keep servocylinder **90°** to bolt.
5. Read bearing (5) radial play on indicator (7). Reading shall not exceed **0.001 inch** for new or overhauled servocylinder (10). Reading shall not exceed **0.003 inch** for inservice servocylinder.

INSPECT

6. Remove indicator (7) from plate (3).

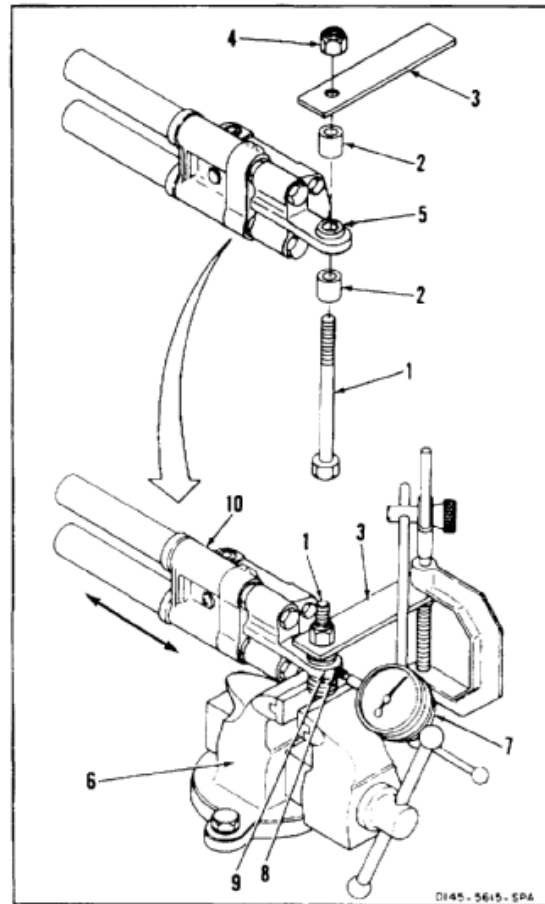

7. Mount indicator (7) on plate (3). Position point (8), against lug (9), then parallel to bolt (1).
8. Push servocylinder (10) up, then down. Keep servocylinder **90°** to bolt (1).
9. Read bearing (5) axial play on indicator (7). Reading shall not exceed **0.004 inch** for new or overhauled servocylinder (10). Reading shall not exceed **0.007 inch** for in-service servocylinder.

INSPECT

10. Remove indicator (7) from plate (3).
11. Remove servocylinder (10) from vise (6).
12. Remove nut (4), plate (3), two spacers (2), and bolt (1) from bearing (5).

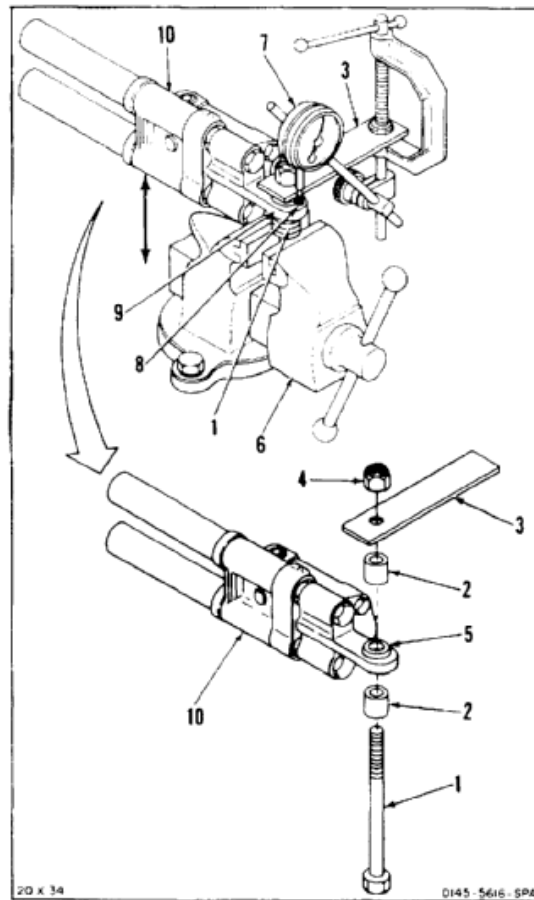

INSPECT PIVOTING SERVOCYLINDER MOUNT BEARING FOR AXIAL AND RADIAL PLAY

13. Install bolt (1), two spacers (2), plate (3), and nut (4) in bearing (11).
14. Clamp head of bolt (1) in vise (6).
15. Mount indicator (7) on plate (3). Position point (8) against servocylinder (10), **90°** to plate (3).
16. Push servocylinder (10) up, then down. Keep servocylinder **90°** to bolt (1).
17. Read bearing (11) axial play on indicator (7). Reading shall not exceed **0.004 inch** for new or overhauled servocylinder (10). Reading shall not exceed **0.007 inch** for in-service servocylinder.

INSPECT

18. Remove indicator (7) from plate (3).

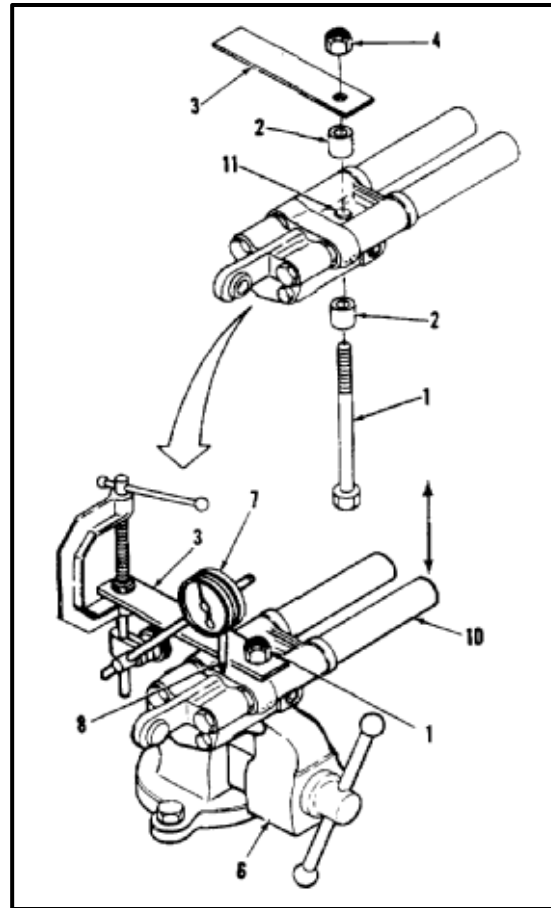

19. Mount indicator (7) on plate (3). Position point (8), against servocylinder (10), parallel to plate.
20. Push servocylinder (10) toward bolt (1), then pull away. Keep servocylinder **90°** to bolt
21. Read bearing (11) radial play on indicator (7). Reading shall not exceed **0.001 inch** for new or overhauled servocylinder (10). Reading shall not exceed **0.003 inch** for in-service servocylinder.

INSPECT

22. Remove indicator (7) from plate (3).
23. Remove servocylinder (10) from vise (6).
24. Remove nut (4), plate (3), two spacers (2), and bolt (1) from bearing (11).

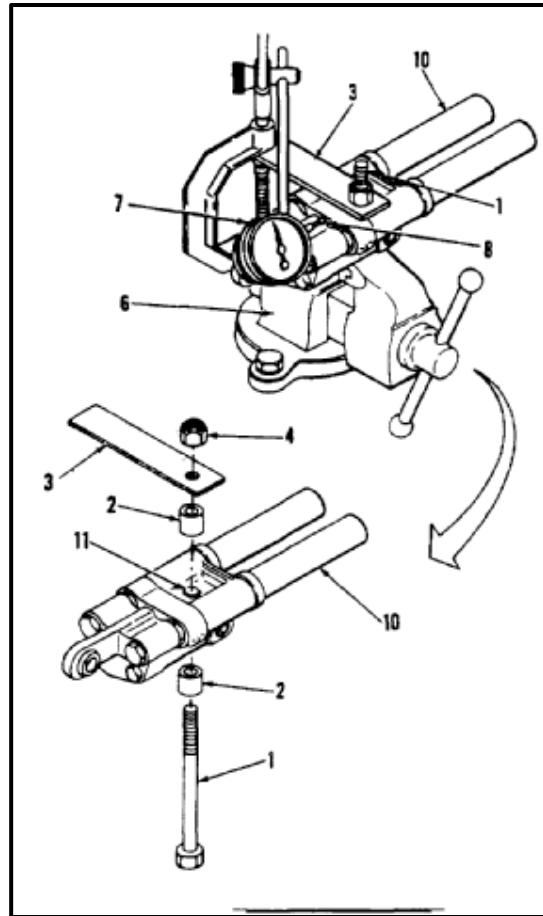

INSPECT SWIVELING SERVOCYLINDER MOUNT BEARINGS FOR AXIAL AND RADIAL PLAY

25. Install bolt (1), two spacers (2), plate (3), and nut (4) in bearing (12).
26. Clamp head of bolt (1) in vise (6).
27. Mount indicator (7) on plate (3). Position point (8) against servocylinder (10), **90°** to plate.
28. Push servocylinder (10) up, then down. Keep servocylinder **90°** to bolt (1).
29. Read bearing (12) axial play on indicator (7). Reading shall not exceed **0.004 inch** for new or overhauled servocylinder (10). Reading shall not exceed **0.007 inch** for in-service servocylinder.

INSPECT

30. Remove indicator (7) from plate (3).

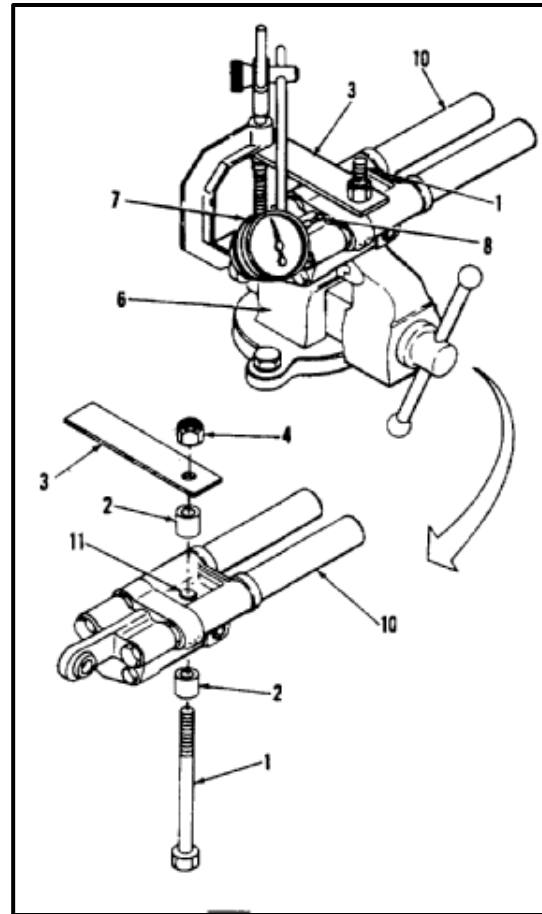

31. Mount indicator (7) on plate (3). Position point (8), against servocylinder (10), parallel to plate.
32. Push servocylinder (10) toward bolt (1), then pull away. Keep servocylinder **90°** to bolt.
33. Read bearing (12) radial play on indicator (7). Reading shall not exceed **0.001 inch** for new or overhauled servocylinder (10). Reading shall not exceed **0.003 inch** for in-service servocylinder.

INSPECT

34. Remove indicator (7) from plate (3).
35. Remove servocylinder (10) from vise (6).
36. Remove nut (4), plate (3), two spacers (2), and bolt (1) from bearing (12).
37. Repeat steps 25 thru 36 for mount bearing (12).

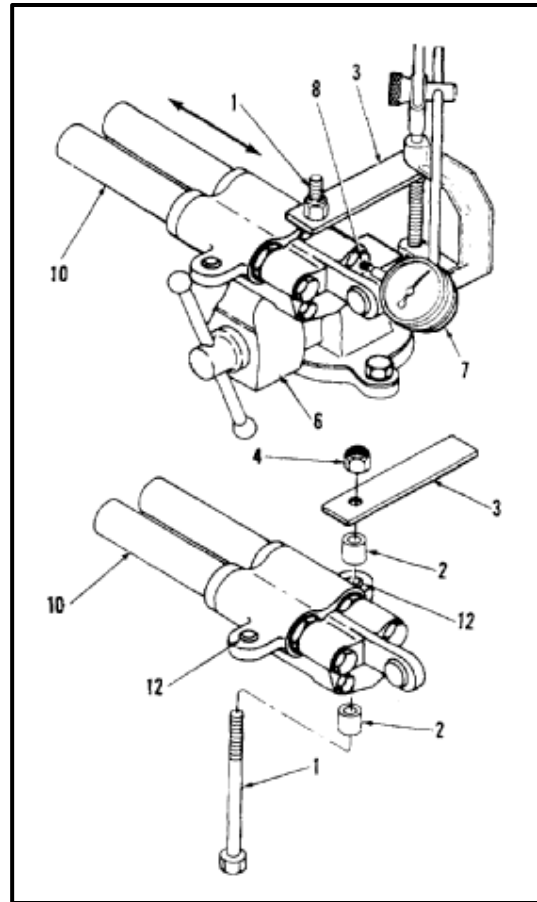
**FOLLOW-ON MAINTENANCE:**

None

END OF TASK

7-576

INITIAL SETUP

Applicable Configurations:

All

Tools:

Hydraulic Repairer's Tool Kit, NSN 5180-00-323-4891
 Arbor Press
 Rivet Tool

Materials:

Paper Tags (E264)
 Epoxy Primer (E292)
 Cadmium Solution (E361)
 Alodine (E65)
 Brush (E86)
 Gloves (E184.1)

Parts:

Screws
 Rivets
 Caps

Personnel Required:

Aircraft Pneudraulics Repairer
 Inspector

References:

MIL-C-5541
 QQ-P-416
 Task 2-350.1

Equipment Condition:

Off Helicopter Task

MOUNTING LUG BEARINGS

1. Remove two screws (1), four washers (2), two spacers (3), and two nuts (4) from four clamps (5 and 6). Remove two clamps (5).
2. Tag and disconnect two tubes (7). Use tag (E264).
3. Install caps (8) on nipples (9), elbows (10), and tees (11).

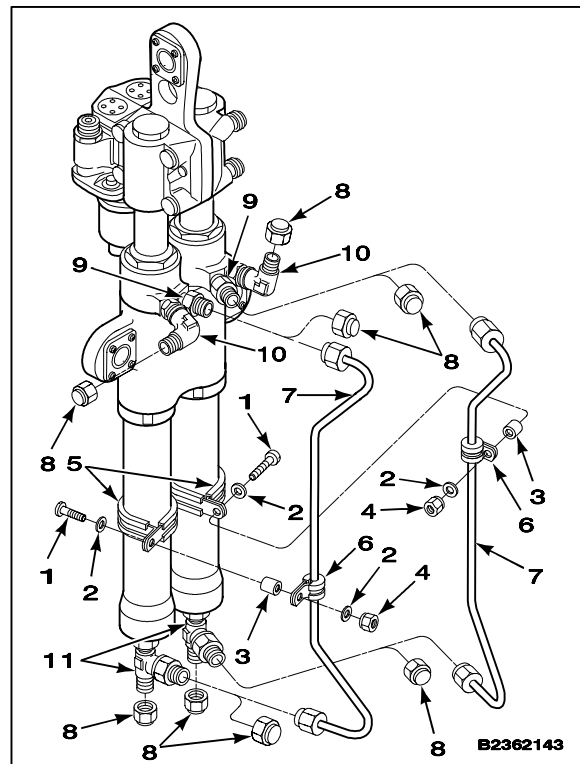
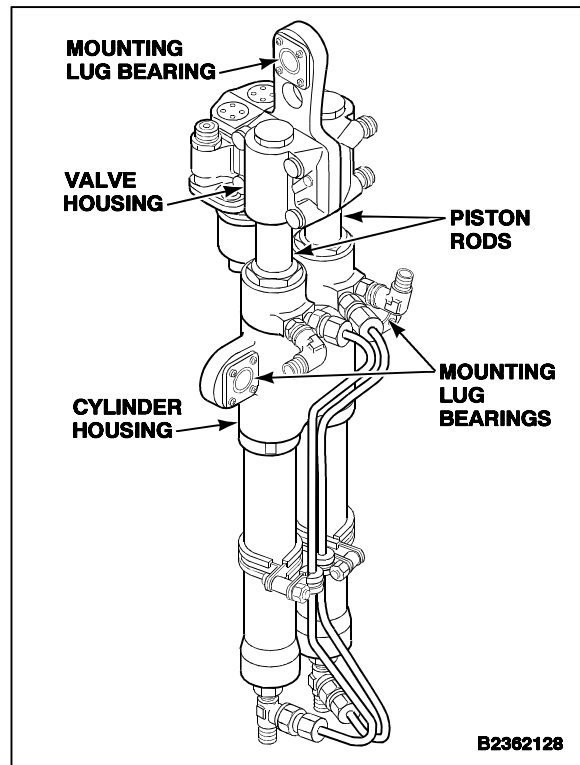

NOTE

Procedure is same to remove and install mounting lug bearings except where noted in text. Upper mounting lug bearing is shown here.

4. Remove four screws (12) from plate (13). Discard four screws (12).

NOTE

Mount bearing plates are installed with four rivets.

5. Remove plate (13) from lug (14).
6. Remove bearing (15) from lug (14). Use arbor press.

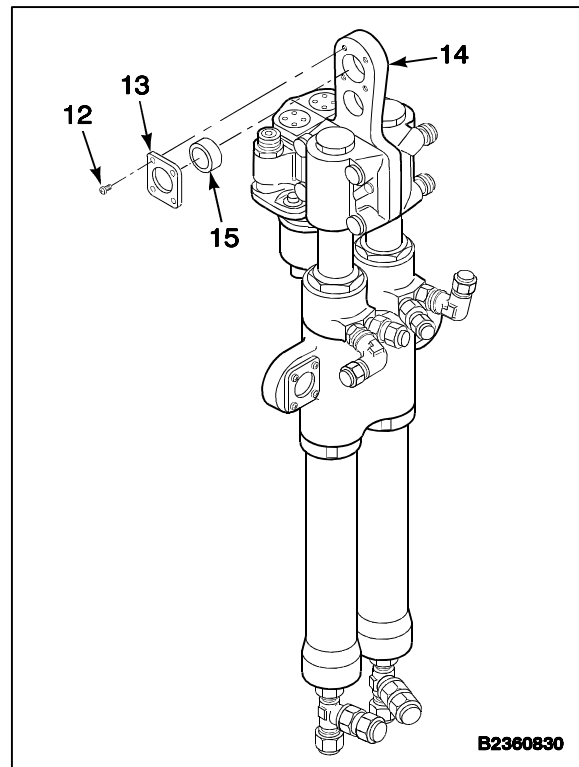

7. Check four holes (16) in plate (13) for elongation. There shall be no elongation.
8. Check four screw holes (17) for damaged threads. Threads shall not be damaged.

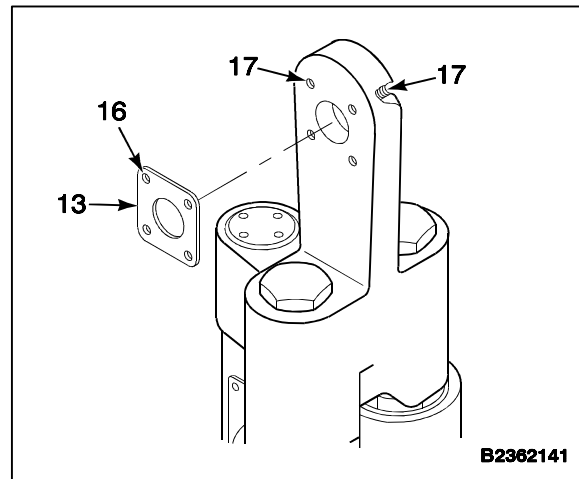

WARNING

Epoxy primer (E292) is flammable and toxic. It can irritate skin and cause burns. Use only with adequate ventilation, away from heat, sparks, and open flame. Avoid contact with skin, eyes, or clothing. In case of contact, immediately flush skin or eyes with water for at least **15 minutes**. Get medical attention for eyes.

9. Coat bearing seat (18) area with epoxy primer (E292) (Task 2-350.1). Wear gloves (E184.1).
10. Install new bearing (15) in seat (18). Use arbor press.
11. Position plate (13) on lug (14). Install four new screws (12).

NOTE

Lower lug bearing plates are installed with four rivets.

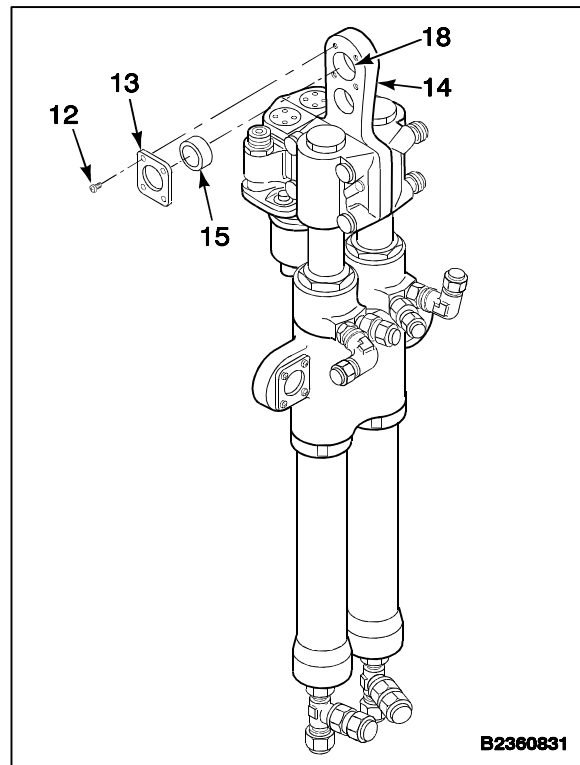

MOUNTING LUGS AND VALVE AND CYLINDER HOUSINGS

12. Remove nicks, scratches, corrosion and pitting by filing, burnishing, honing, polishing, or hand stoning within the following limits:
- Repair of mounting lugs (14 and 20), valve (21), and cylinder (22) housing surfaces must not be more than a depth of **0.040 inch or 10 percent** of material thickness, whichever is less.
 - Repaired areas must clear holes and radii a minimum of **0.750 inch**.

WARNING

Cadmium solution (E361) is extremely toxic. It can irritate skin and cause burns. Use only with adequate ventilation. Do not inhale. Do not contact eyes, skin, or clothing. In case of contact, immediately flush skin or eyes with water for at least **15 minutes**. Get medical attention for eyes.

13. Apply cadmium solution (E361) (Spec QQ-P-416) with brush (E86) on repaired surfaces (14, 20, 21, and 22). Wear gloves (E184.1).

WARNING

Alodine (E65) is an oxidizer. Discard cloths which contain this material in a separate container. If discarded with cloths contaminated with acetone, MEK, or other organic solvents, combustion can result. In case of contact, immediately flush skin or eyes with water for at least **15 minutes**. Get medical attention for eyes.

14. Apply alodine (E65) (Spec MIL-C-5541) to end caps (23) and spring housing (24) damaged surfaces. Wear gloves (E184.1).

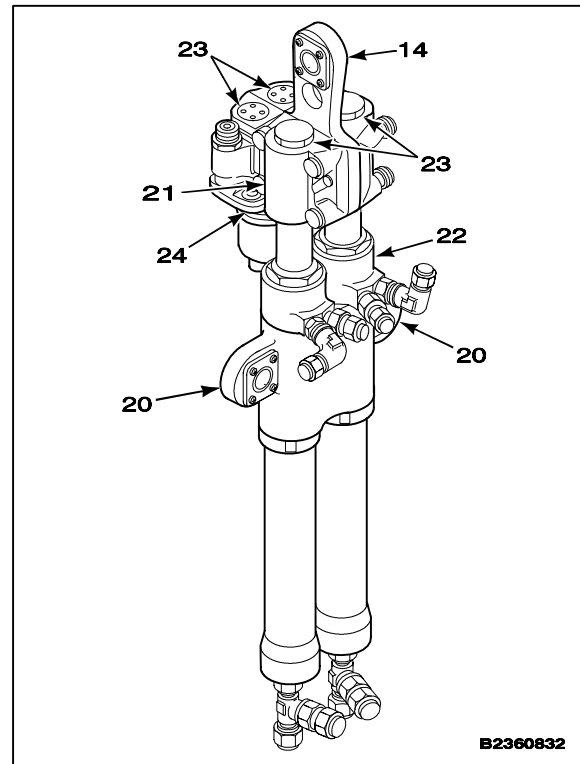

PISTON RODS

15. Remove caps (8) from nipples (9), elbows (10), and tees (11).
16. Hold housing (22) and pull housing (21) until piston rods (25) are extended about **12 inches**.
17. Check piston rods (25). Chromed surface must not be worn or scored through to plating surface.

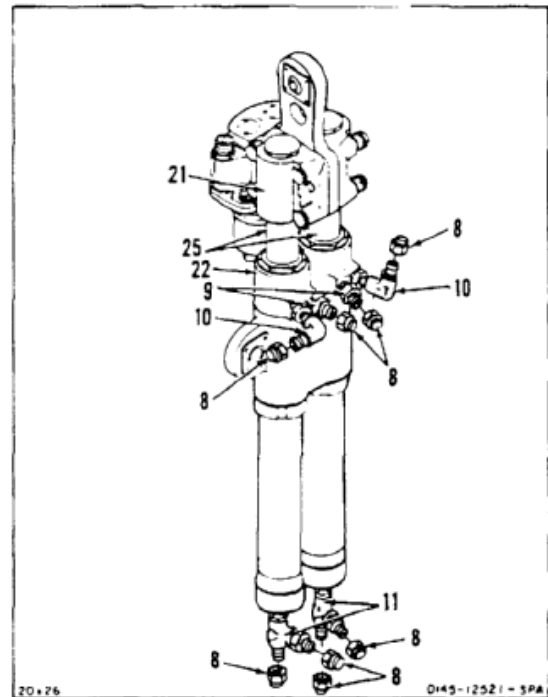

18. Connect two tubes (7). Remove tags.
19. Install two clamps (5) on housing (22).
20. Position two clamps (5) to two clamps (6). Install two spacers (3), two screws (1), four washers (2), and two nuts (4).

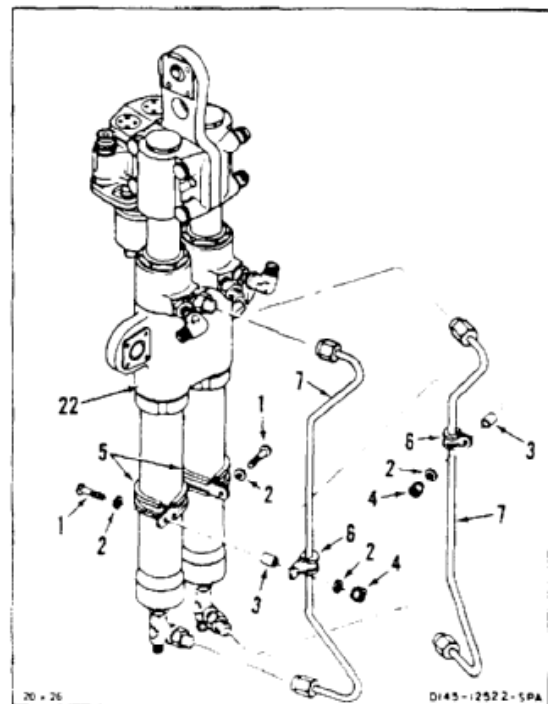
INSPECT**FOLLOW-ON MAINTENANCE:**

Perform inspect servocylinder bearing for radial and axial play (Task 7-128).

END OF TASK

INITIAL SETUP

Applicable Configurations:

All

Tools:

Fixture (APP E-32)
 Spanner Wrench, 114G1150-1
 Torque Wrench, 500 to 1000 Inch-Pounds
 Strap Wrench
 Vise

Materials:

None

Parts:

None

Personnel Required:

Medium Helicopter Repairer (2)

References:

Task 7-129
 TM 55-1520-240-23P

Equipment Condition:

Off Helicopter Task

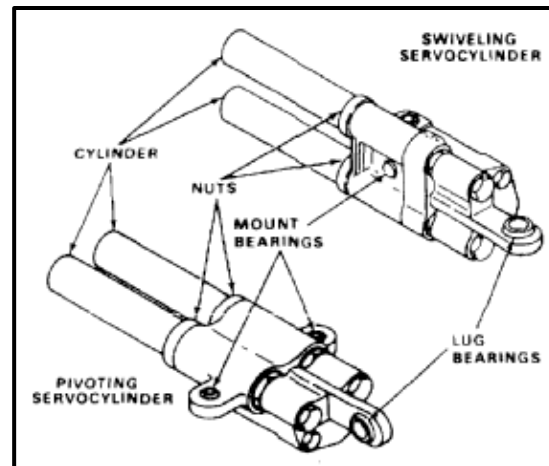
**NOTE**

Procedure is similar for torque check on both swiveling and pivoting servocylinders.

NOTE

Swiveling servocylinder shown. When checking pivoting servocylinder, use outer mount bearing to secure it in vise.

7-129.1 PIVOTING AND SWIVELING SERVOCYLINDER NUT TORQUE CHECK (Continued)

7-129.1

1. Attach bolt (1), two spacers (2), plate (3), and nut (4), to bearing (5) of servocylinder.
2. Clamp head of bolt (1) in vise (6).
3. Remove lockwire and inspect nuts (7) for looseness.
4. Put a strap wrench on one of the cylinders (8) to hold it from turning.



Cylinders must not turn during this check. Internal cylinder positioning pin will be damaged.

5. Check torque of nuts (7) on cylinder (8). Check torque (clockwise direction) to **800 inch-pounds**. If nuts are tight proceed to step 7.
6. If nuts (7) are not properly torqued, retorque to **800 inch-pounds**.
7. Lockwire nuts. Use lockwire (E231).
8. Repeat steps 1 thru 5 on second cylinder of the servocylinder.

FOLLOW-ON MAINTENANCE:

None

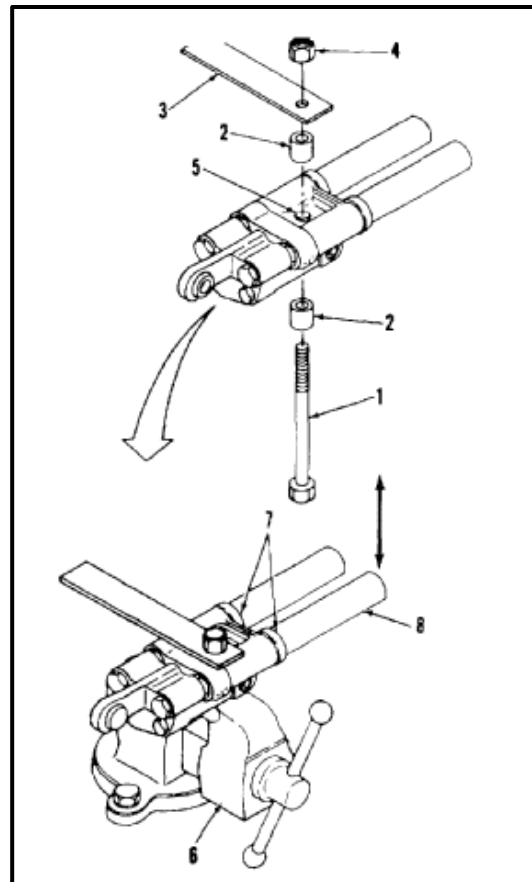

END OF TASK

INITIAL SETUP

Applicable Configurations:

All

Tools:

Hydraulic Repairer's Tool Kit, NSN 5180-00-323-4891
 Arbor Press
 Rivet Tool

Materials:

Paper Tags (E264)
 Epoxy Primer (E292)
 Cadmium Solution (E361)
 Alodine (E65)
 Brush (E86)
 Gloves (E184.1)

Parts:

Rivet
 Screws
 Caps

Personnel Required:

Aircraft Pneudraulics Repairer
 Aircraft Structural Repairer
 Inspector

References:

MIL-C-5541
 QQ-P-41 6
 Task 2-350.1

Equipment Condition:

Off Helicopter Task

General Safety Instructions:**WARNING**

Epoxy primer (E292) is flammable and toxic. It can irritate skin and cause burns. Use only with adequate ventilation, away from heat sparks, and open flame. Avoid contact with skin, eyes, or clothing. In case of contact, immediately flush skin or eyes with water for at least **15 minutes**. Get medical attention for eyes

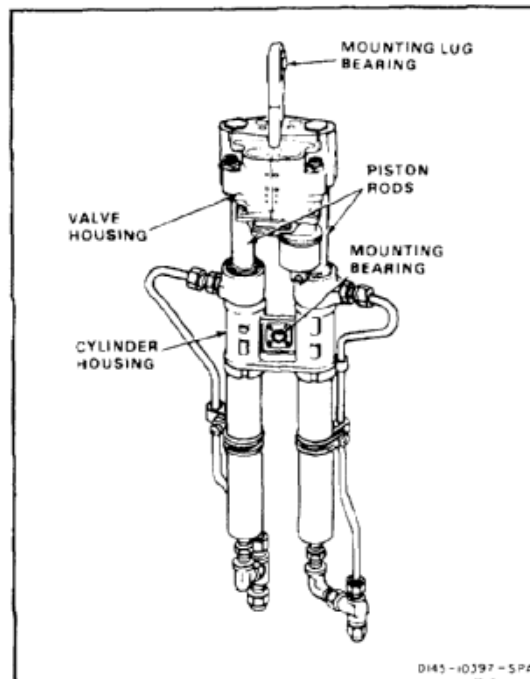

MOUNTING LUG BEARINGS

1. Remove two screws (1), washers (2), and nuts (3) from two clamps (4 and 5). Remove two clamps (5).
2. Tag and disconnect two tubes (6).
3. Install caps (7) on nipples (8) and tee (9).

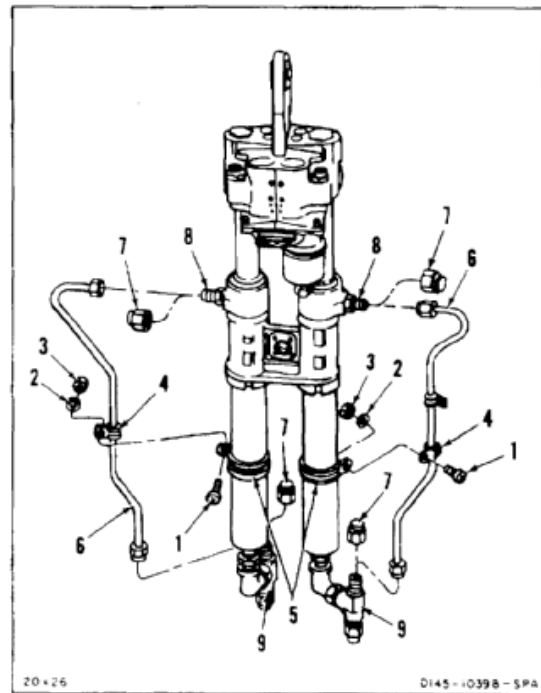

NOTE

Procedure is same to remove or install upper mounting lug bearing, except where noted in text. Lower mounting bearing is shown here.

4. Remove four rivets (10) from two plates (11).

NOTE

Upper mount bearing plates are installed with screws.

5. Remove two plates (11) from servocylinder (12).
6. Remove bearing (13) from mount (14). Use arbor press.

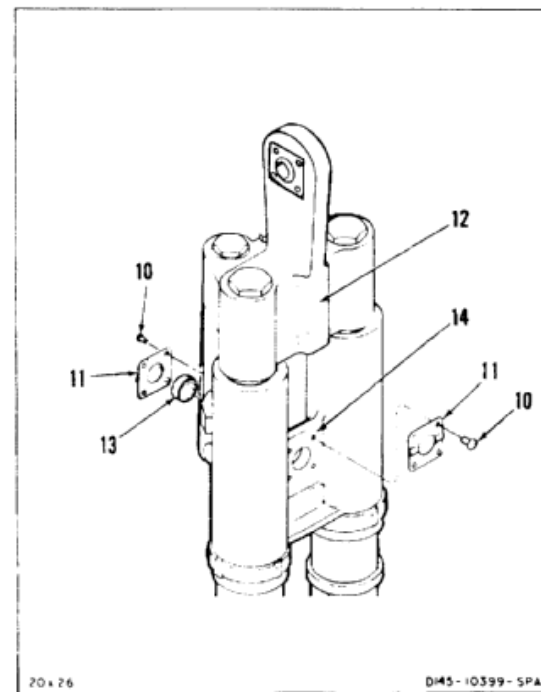

7. Check eight holes (15) in two plates (11) for elongation. There shall be no elongation.

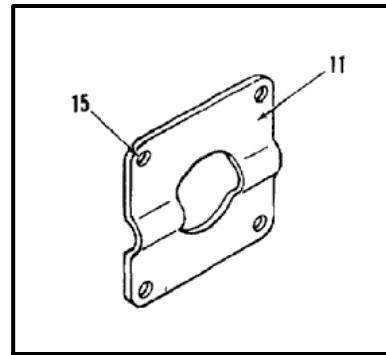

8. Coat bearing seat (16) area with epoxy primer (E292) (Task 2-350.1). Wear gloves (E184.1).
9. Install new bearing (13) in seat (16). Use arbor press.



Make sure antirotation pads on retainer plates are installed in horizontal position. Otherwise, servocylinder will be damaged.

10. Position two plates (11) on mount (14) with antirotation pads (17) as shown. Install four rivets (10).
11. Check rivets are flush. If not, file or grind off excess metal. Coat rivets with epoxy primer (E292) (Task 2-350.1). Wear gloves (E184.1).

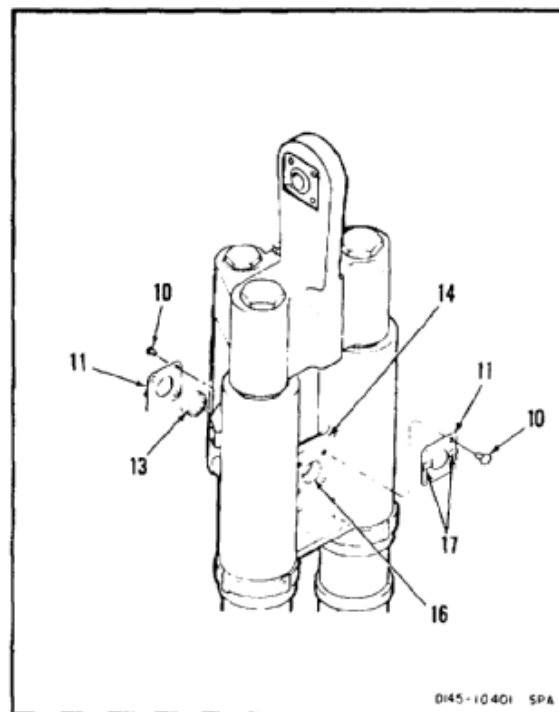

MOUNTS AND VALVE AND CYLINDER HOUSINGS

12. Remove nicks, scratches, corrosion, and pitting by filing, burnishing, honing, polishing, or hand stoning within the following limits.
- Repair of mounts (14 and 18), valve (19), and cylinder (20) housing surfaces must not be more than a depth of **0.040 inch or 10 percent** of material thickness, whichever is less.
 - Repaired areas must clear holes and radii a minimum of **0.750 inch**.

WARNING

Cadmium solution (E361) is extremely toxic. It can irritate skin and cause burns. Use only with adequate ventilation. Do not inhale. Do not contact eyes, skin, or clothing. In case of contact, immediately flush skin or eyes with water for at least **15 minutes**. Get medical attention for eyes.

13. Apply cadmium solution (E361) (Spec QQ-P-416) with brush (E86) on repaired surfaces (14, 18, 19, and 20). Wear gloves (E184.1).

WARNING

Alodine (E65) is an oxidizer. Discard cloths which contain this material in a separate container. If discarded with cloths contaminated with acetone, MEK, or other organic solvents, combustion can result. In case of contact, immediately flush skin or eyes with water for at least **15 minutes**. Get medical attention for eyes.

14. Apply alodize (E65) (Spec MIL-C-5541) to end caps (21), and spring housing (22) damaged surfaces. Wear gloves (E184.1).

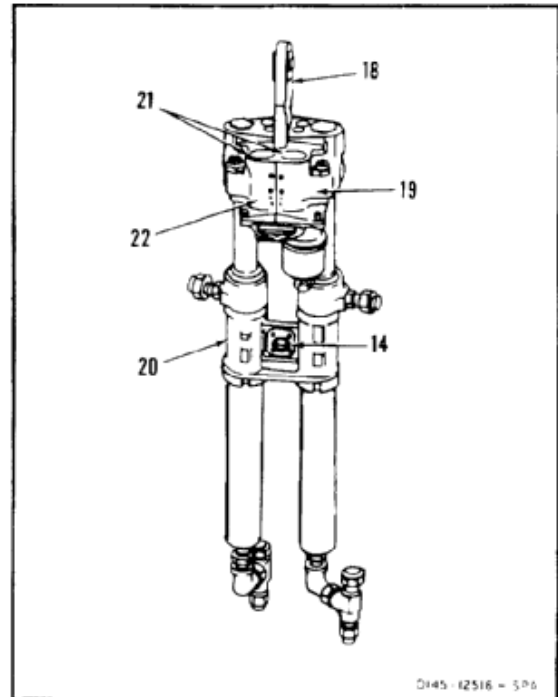

PISTON RODS

15. Remove caps (7) from nipples (8) and tees (9).
16. Hold housing (20) and pull housing (22) until piston rods (23) are extended about **12 inches**.
17. Check piston rods (23). Chromed surface must not be worn or scored through to plating surface.

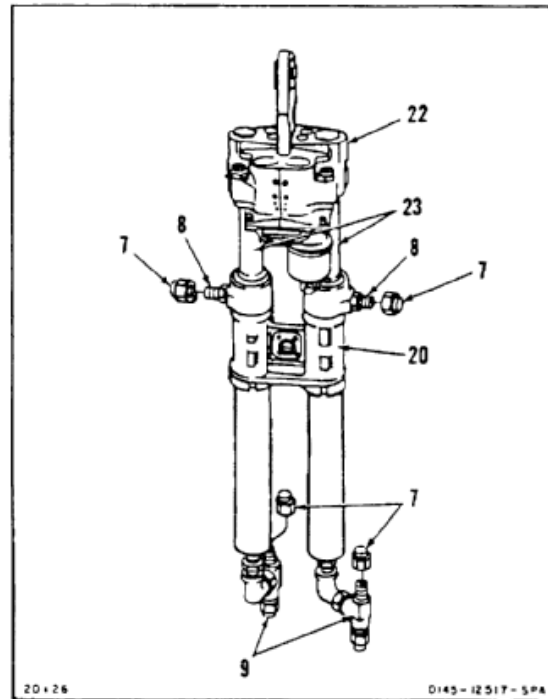

18. Connect two tubes (6). Remove tags.
19. Install two clamps (5) on housing (20).
20. Position two clamps (5) to two clamps (6). Install two spacers (3), two screws (1), and two nuts (4).

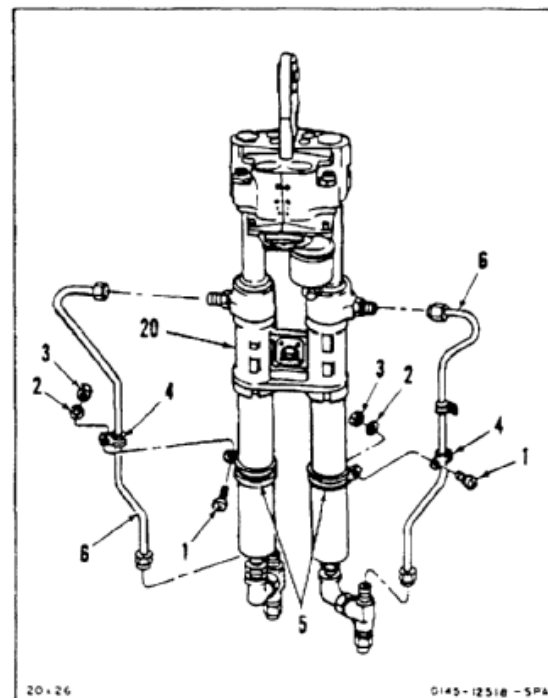
INSPECT**FOLLOW-ON MAINTENANCE:**

Perform inspect servocylinder bearing for radial and axial play (Task 7-128).

END OF TASK

7-588

7-131 INSTALL FORWARD PIVOTING SERVOCYLINDER

7-131

INITIAL SETUP**Applicable Configurations:**

All

Tools:

Aircraft Mechanic's Tool Kit, NSN 5180-00-323-4692
Torque Wrench, 0 to 150 Inch-Pounds
Torque Wrench, 100 to 750 Inch-Pounds

Materials:

Antiseize Compound (E75)
Gloves (E184.1)

Parts:

Preformed Packings
Cotter

Personnel Required:

Medium Helicopter Repairer (2)
Inspector

References:

Task 7-123
TM 55-1520-240-23P

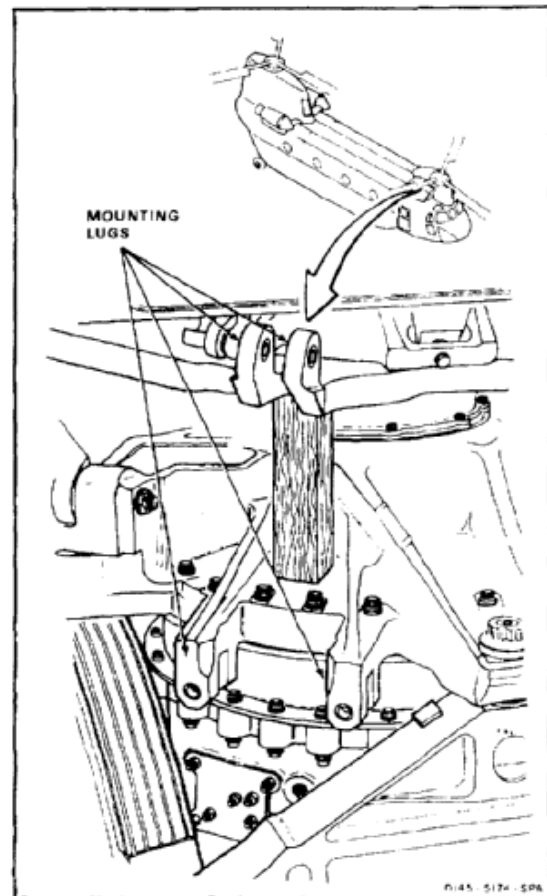

NOTE

All overhauled actuators must have a suffix "N" behind the serial number. (Suffix "N" indicates the actuator has been adjusted in accordance with TB 1-1520-240-20-85, this is not required on new actuators.)

1. Install elbow (1), tee (2), and packing (3) in servocylinder (4). Do not tighten nut (5) at this time.
2. Install elbow (6), tee (7), and packing (8) in servocylinder (4). Do not tighten nut (9) at this time.
3. Install elbow (10) and packing (11) in port (12). Do not tighten nut (13) at this time.
4. Install elbow (14) and packing (15) in port (16). Do not tighten nut (17) at this time.
5. Slide clamp (18) on servocylinder (4).
6. Slide clamp (19) on servocylinder (4).
7. Install two packings (20), and valves (21) in ports (12 and 16).
8. Connect tube (22) to tee (2) and port (12). Remove tag.
9. Position clamp (18) on clamp (23). Install screw (24), washer (25), and nut (26). Do not tighten nut at this time.
10. Connect tube (27) to tee (7) and port (16). Remove tag.
11. Position clamp (19) on clamp (28). Install screw (29), washer (30), and nut (31). Do not tighten nut at this time.

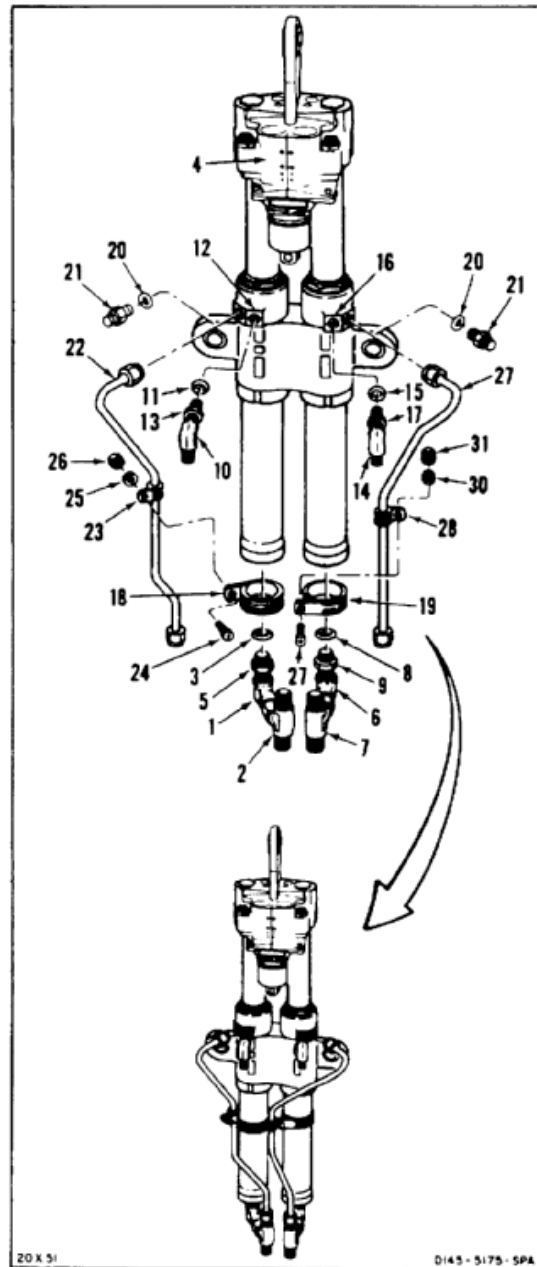

WARNING

Make sure bushings are installed in lugs. Otherwise, personal injury, loss of life, or loss of helicopter can result.

12. Check that bushings are securely installed in both inboard lugs (32) and outboard lugs (33). Check that outboard bushings do not extend beyond inner or outer faces of lugs. If they do, replace forward transmission.
13. Have helper on work platform support servocylinder (4). Position mounts (34) between lugs (32 and 33).

INSTALL SERVOCYLINDER WITHOUT 50**WARNING**

Make sure slip fit bushings are installed on shanks of bolts. Otherwise, personal injury, loss of life, or loss of helicopter can result.

NOTE

Install countersunk washers with countersink against bolt head.

Two washers may be installed under nut to allow for cotter pin installation.

- 13.1. Check that countersunk washer (35), washer (35.1) and slip fit bushing (35.2) are installed on shank of each bolt (36). Install bolts through lugs (32 and 33). Install one or two washers (37) and nut (38) on each bolt. Go to step 14.

INSTALL SERVOCYLINDER WITH 50

- 13.2. Install bolts through lugs (32 and 33). Install one or two washers (37) and nut (38) on each bolt. Go to step 14.
14. Torque bolts (36) to **320 to 720 inch-pounds**. Install cotter pins (39).

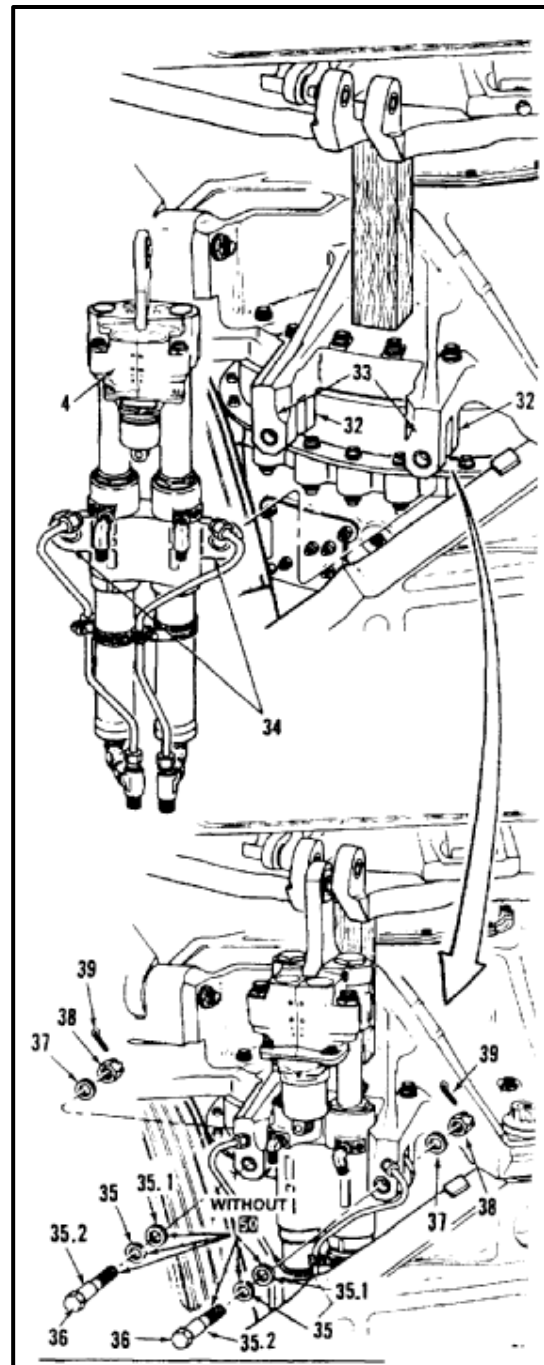

15. Install inner bushing (43.1) and outer bushing (43.2). Position link (42) between two lugs (43). Install bolt (44), with one washer (45) through bushings and lugs, one washer (45) and nut (46).
16. Torque nut (46) to **30 to 45 inch-pounds**. Install cotter pin (47).
17. Check bolt (44). Bolt shall not rotate with torque less than **10 inch-pounds**. There shall be no axial looseness. If bolt rotates, or is loose, add washer under nut. Torque and cotter pin nut again.
18. Remove block (48) from under swashplate (49).

WARNING

Antiseize compound (E75) can irritate skin and cause burns. Avoid contact with skin, eyes, or clothing. In case of contact, immediately flush skin or eyes with water for at least **15 minutes**. Get medical attention for eyes.

19. Tilt swashplate (49) and position bearing (50) between two lugs (51). Install bolt (52), two washers (53), and nut (54). Coat shank of bolt and outside diameter of bushing with antiseize compound (E75). Do not get compound on thread of bolt. Wear gloves (E184.1).
20. Torque nut (54) to **400 to 660 inch-pounds** (includes cotter pin installation). A third (AN960-816L) washer (45), may be required for cotter pin alignment. Install cotter pin (55).
- 20.1. Inspect installation (Task 7-123).
21. Connect hose (56) to elbow (10). Tighten nut (13). Remove tag.
22. Connect hose (57) to elbow (14). Tighten nut (17). Remove tag.

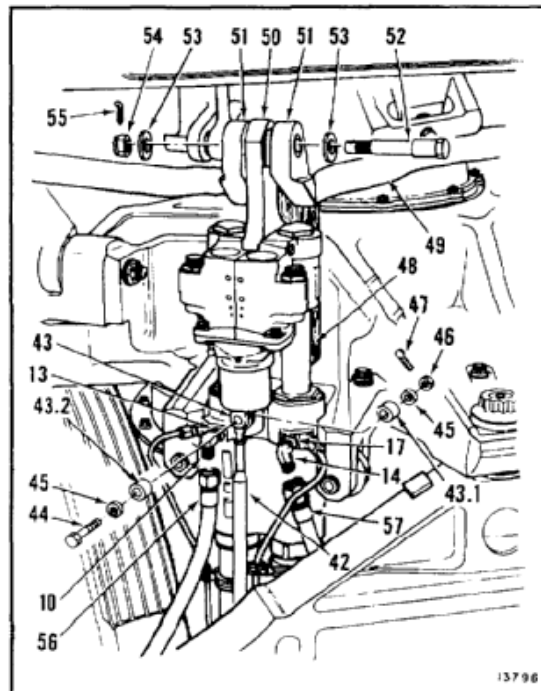

13798

23. Have helper in passageway. Connect hose (58) to tee (2). Remove tag. Tighten nut (9).
24. Connect hose (59) to tee (7). Remove tag. Tighten nut (5).

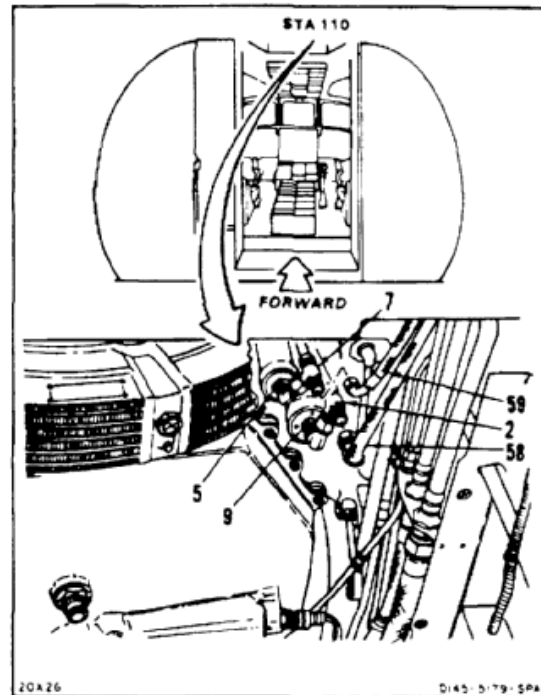
INSPECT**FOLLOW-ON MAINTENANCE:**

- Connect forward pitch links (Task 5-99).
- Bleed flight control hydraulic system (Task 7-16).
- Perform neutral rigging check (Task 11-33).
- Install forward transmission drip pan (Task 2-3).
- Close right forward work platform (Task 2-2).

END OF TASK

INITIAL SETUP

Applicable Configurations:

All

Tools:

Aircraft Mechanic's Tool Kit, NSN 5180-00-323-4692
Torque Wrench, 0 to 150 Inch-Pounds
Torque Wrench, 100 to 750 Inch-Pounds
Torque Wrench, 700 to 1600 Inch-Pounds

Materials:

Antiseize Compound (E75)
Gloves (E184.1)

Parts:

Preformed Packings
Cotter Pins

Personnel Required:

Medium Helicopter Repairer (2)
Inspector

References:

Task 7-123
TM 55-1520-240-23P

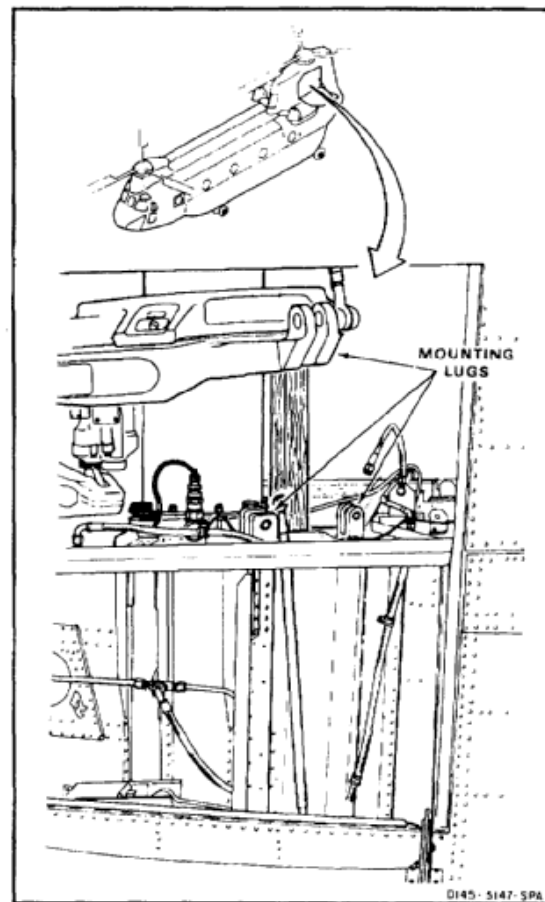

NOTE

All overhauled actuators must have a suffix "N" behind the serial number. (Suffix "N" indicates the actuator has been adjusted in accordance with TB 1-1520-240-20-85, this is not required on new actuators.)

1. Install tee (1) and packing (2) in servocylinder (3). Do not tighten nut (4) at this time.
2. Install tee (5) and packing (6). Do not tighten nut (7) at this time.
3. Install elbow (8) and packing (9). Do not tighten nut (10) at this time.
4. Install elbow (11) and packing (12). Do not tighten nut (13) at this time.
5. Install nipple (14) and packing (15).
6. Install nipple (16) and packing (17).
7. Slide clamps (18 and 19) on servocylinder (3).
8. Connect tube (20) to tee (1) and nipple (14).
9. Align clamp (18) and clamp (21). Install screw (22), two washers (23), spacer (24), and nut (25). Tighten nut (4).
10. Connect tube (26) to tee (5) and nipple (16).
11. Align clamp (19) and clamp (27). Install screw (28), two washers (29), spacer (30), and nut (31). Tighten nut (7).

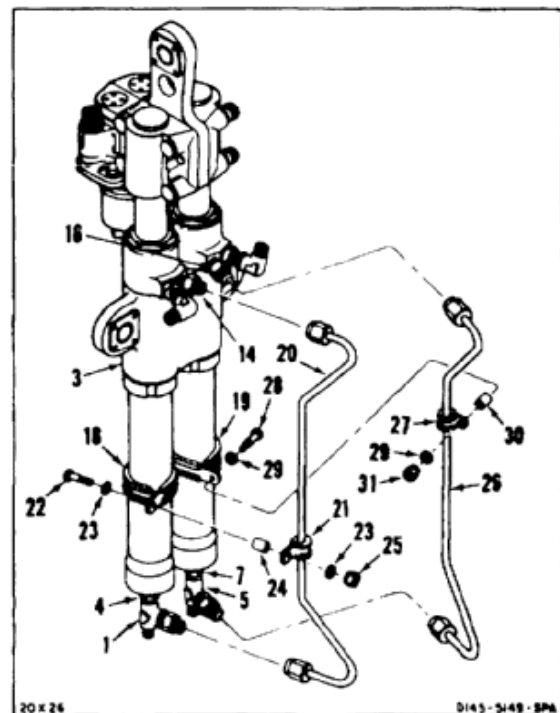
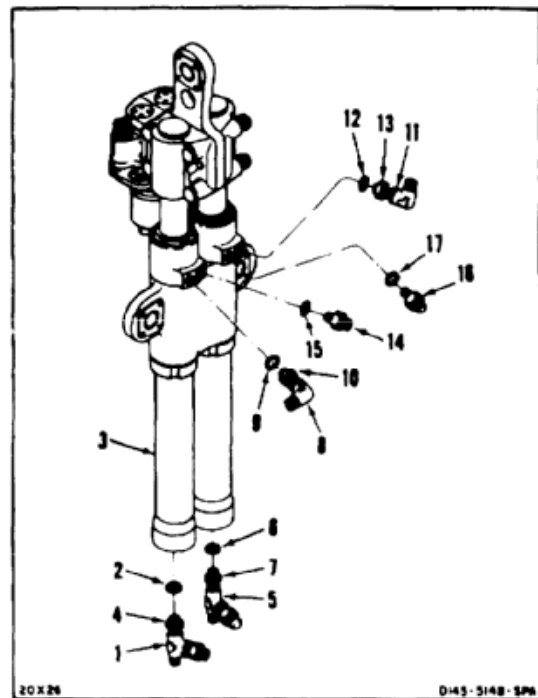

WARNING

Make sure bushings are installed in lugs. Otherwise, personal injury, loss of life, or loss of helicopter can result.

12. Check that flanged bushings (32) are installed in forward inboard lug (33) and aft outboard lug (33.1).
13. Have helper support cylinder (3). Position cylinder mounts (34) between lugs (33 and 33.1).

NOTE

Two washers may be installed under nut to allow for cotter pin installation.

Install countersunk washers with countersink against bolthead.

- 13.1. Install forward bolt (35) as follows:
 - a. Insert slip fit bushing (35.1) in outboard lug (35.2).
 - b. Install countersunk washer (36) and washer (36.1) on bolt (35).
 - c. While holding bushing (35.1) in position, install bolt (35). Install one or two washers (37) and nut (38).
- 13.2. Install aft bolt (35) as follows:
 - a. Install countersunk washer (36), washer (36.1), and slip fit bushing (35.1) on bolt (35).
 - b. Install bolt (35). Install one or two washers (37) and nut (38).
14. Torque nuts (38) to **290 to 660 inch-pounds**. Install cotter pins (39).
15. Install inner bushing (41.1) and outer bushing (41.2). Position link (40) in lugs (41). Install bolt (42) with one washer (43) through bushings and lugs, one washer (43), and nut (44).
16. Torque nut (44) to **30 to 45 inch-pounds**. Install cotter pin (45).
17. Check bolt (42). Bolt shall not rotate with torque less than **10 inch-pounds**. There shall be no axial looseness. If bolt rotates, or is loose, add washer under nut. Torque and cotter pin nut again.

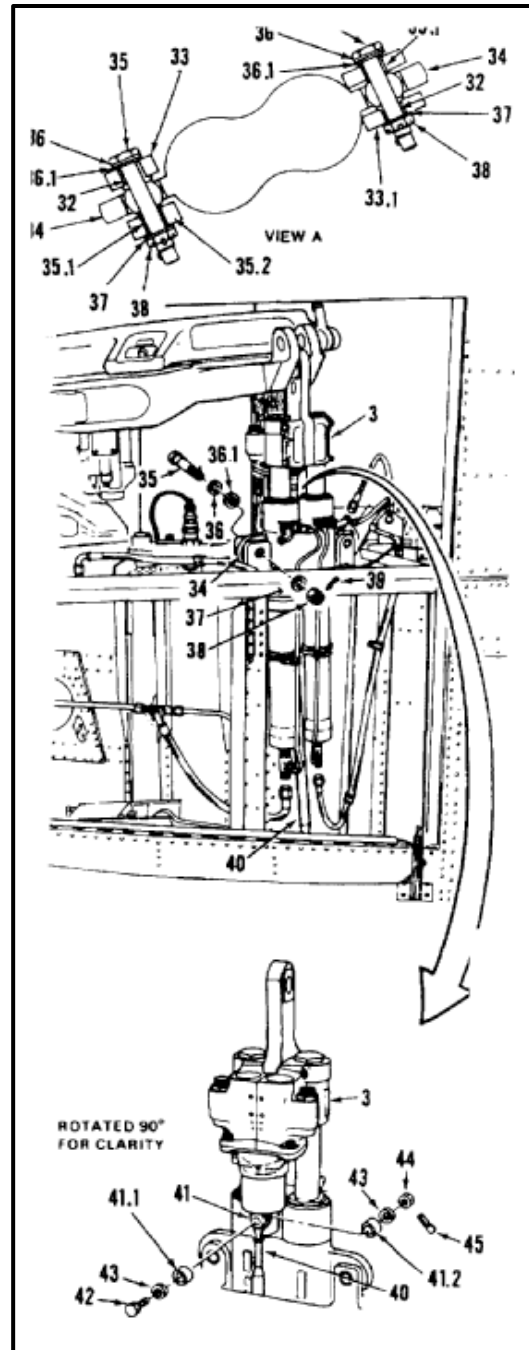

18. Remove block (46) from under swashplate (47).

WARNING

Antiseize compound (E75) can irritate skin and cause burns. Avoid contact with skin, eyes, or clothing. In case of contact, immediately flush skin or eyes with water for at least **15 minutes**. Get medical attention for eyes.

19. Tilt swashplate (47) and position bearing (48) between two lugs (33). Install bolt (49), washer (50), and nut (51). Coat shank of bolt and outside diameter of bushing with antiseize (E75). Do not get antiseize on bolt thread. Wear gloves (E184.1).
20. Torque nut (51) to **660 to 780 inch-pounds, 1400 inch-pounds** maximum for cotter pin alignment. Install cotter pin (52).
- 20.1. Inspect installation (Task 7-123).
21. Connect hose (53) to elbow (8). Remove tag. Tighten nut (10).
22. Connect hose (54) to elbow (11). Remove tag. Tighten nut (13).
23. Connect hose (55) to tee (1). Remove tag.
24. Connect hose (56) to tee (5). Remove tag.

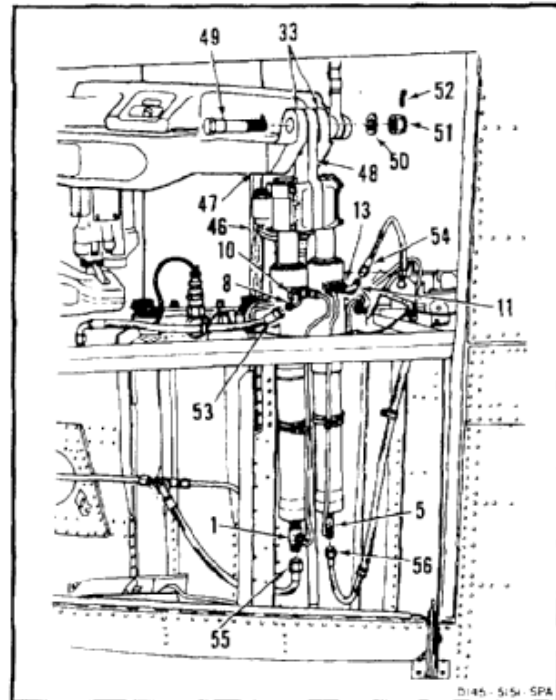

INSPECT

FOLLOW-ON MAINTENANCE:

- Connect aft pitch links (Task 5-99).
 Bleed flight control hydraulic system (Task 7-16).
 Perform flight control operational check (TM 55-1520-240-T).
 Perform neutral rigging test (Task 11-33).
 Close aft left work platform (Task 2-2).

END OF TASK

INITIAL SETUP

Applicable Configurations:

All

Tools:

Aircraft Mechanic's Tool Kit, NSN 5180-00-323-4692
 Torque Wrench, 0 to 150 Inch-Pounds
 Torque Wrench, 100 to 750 Inch-Pounds

Materials:

Antiseize Compound (E75)
 Gloves (E184.1)

Parts:

Preformed Packings
 Cotter Pins

Personnel Required:

Medium Helicopter Repairer (2)
 Inspector

References:

Task 7-123
 TM 55-1520-240-23P

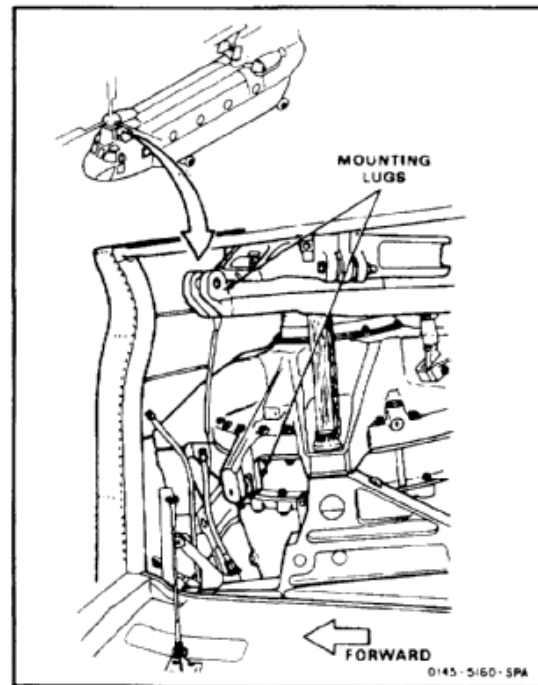
**NOTE**

All overhauled actuators must have a suffix "N" behind the serial number (Suffix "N" indicates the actuator has been adjusted in accordance with TB 1-1520-240-20-85, this is not required on new actuators.)

1. Install elbow (1), tee (2), and packing (3) in servocylinder (4). Do not tighten nut (5) at this time.
2. Install elbow (6), tee (7), and packing (8). Do not tighten nut (9) at this time.
3. Install elbow (10) and packing (11). Do not tighten nut (12) at this time.
4. Install elbow (13) and packing (14). Do not tighten nut (15) at this time.
5. Install valve (16) and packing (17).
6. Install valve (18) and packing (19).
7. Slide clamp (20) on servocylinder (4).
8. Slide clamp (21) on servocylinder (4).
9. Connect tube (22) to tee (2) and valve (16). Remove tag.
10. Position clamp (20) on clamp (23). Install screw (24), washer (25), and nut (26). Tighten nut (5).
11. Connect tube (27) to tee (7) and valve (18). Remove tag.
12. Position clamp (21) on clamp (28). Install screw (29), washer (30), and nut (31). Tighten nut (9).

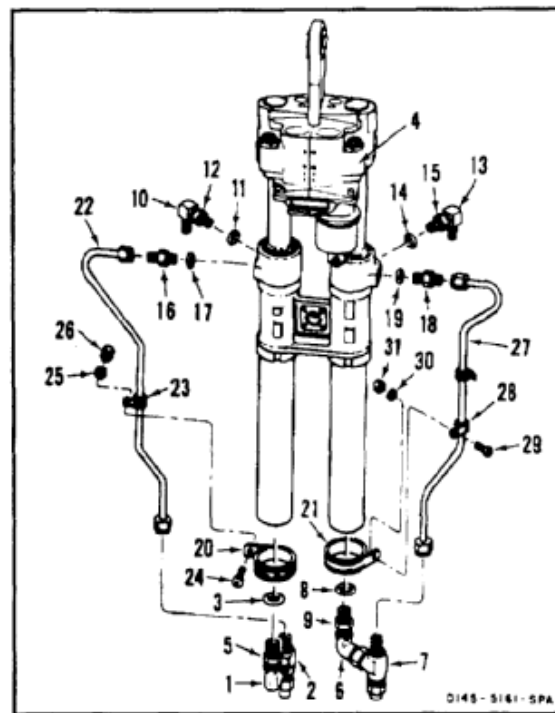

INSTALL SERVOCYLINDER WITHOUT 50**WARNING**

Make sure slip bushings are installed in lug. Otherwise, personal injury, loss of life, or loss of helicopter can result.

13. Check that bushings (32) are installed in lugs (33).

NOTE

Two washers may be installed under nut to allow for cotter pin installation.

Install countersunk washers with countersink against bolthead.

14. Have helper on work platform support servocylinder (4). Position mounts (34) in lugs (33).
- 14.1. Install bolt (35) with countersunk washer (36), washer (36.1), and slip bushing (36.2) through lugs (33). Install one or two washers (36.3) and nut (37) on bolt. Go to step 15.

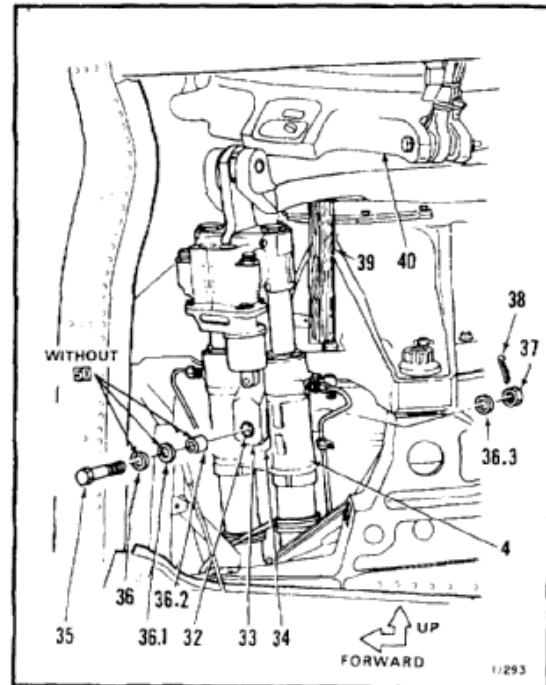
**INSTALL SERVOCYLINDER WITH 50**

- 14.2. Install bolt (35) through lugs (33). Install one or two washers (36.3) and nut (37) on bolt.
15. Torque bolt (35) to **320 to 720 inch-pounds**. Install cotter pins (38).
16. Remove block (39) from under swashplate.

WARNING

Antiseize compound (E75) can irritate skin and cause burns. Avoid contact with skin, eyes, or clothing. In case of contact, immediately flush skin or eyes with water for at least **15 minutes**. Get medical attention for eyes.

17. Tilt swashplate (40) and position bearing (41) between lugs (42). Install bolt (43), washer (44), and nut (45). Coat shank of bolt and outside diameter of bushing with antiseize compound (E75). Do not get compound on thread of bolt. Go to step 18. Wear gloves (E184.1).

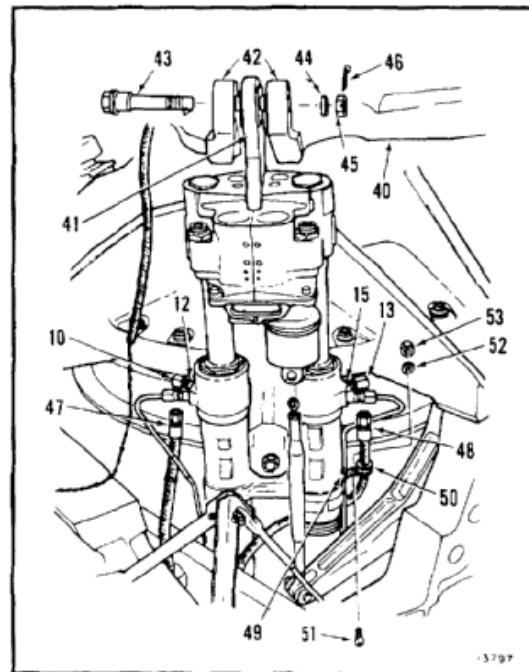

18. Torque nut (45) **400 to 660 inch-pounds** (includes cotter pin installation). A third (AN960-816L) washer (44), may be required for cotter pin alignment. Install cotter pin (46).
- 18.1. Inspect installation (Task 7-123).
19. Connect hose (47) to elbow (10). Tighten nut (12). Remove tag.
20. Connect hose (48) to elbow (13). Tighten nut (15). Remove tag.
21. Position clamp (49) on clamp (50). Install screw (51), washer (52), and nut (53).
22. Install inner bushing (55.1) and outer bushing (55.2). Align link (54) with lugs (55). Install bolt (56) with one washer (57) through bushings and lugs, one washer (57) and nut (58).
23. Torque nut (58) **30 to 45 inch-pounds**. Install cotter pin (59).
24. Check bolt (56). Bolt shall not rotate with torque less than **10 inch-pounds**. There shall be no axial looseness. If bolt rotates, or is loose, add washer under nut. Torque and cotter pin nut again.

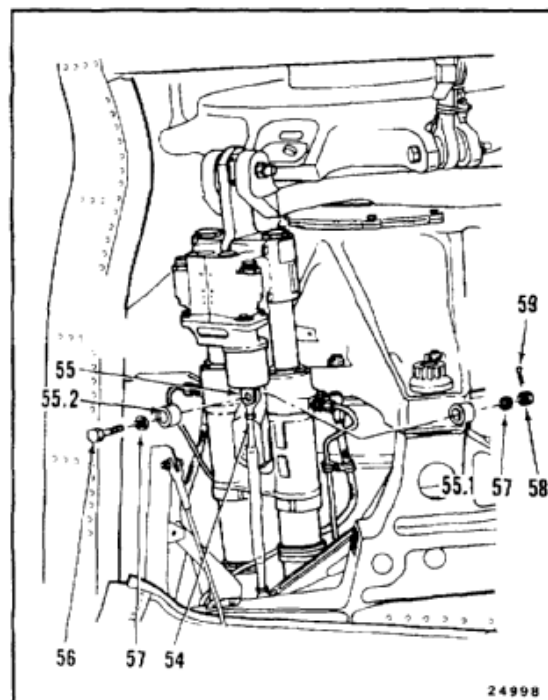

25. From passageway, connect hose (60) to tee (61). Remove tag.
26. Connect hose (62) to tee (63). Remove tag.

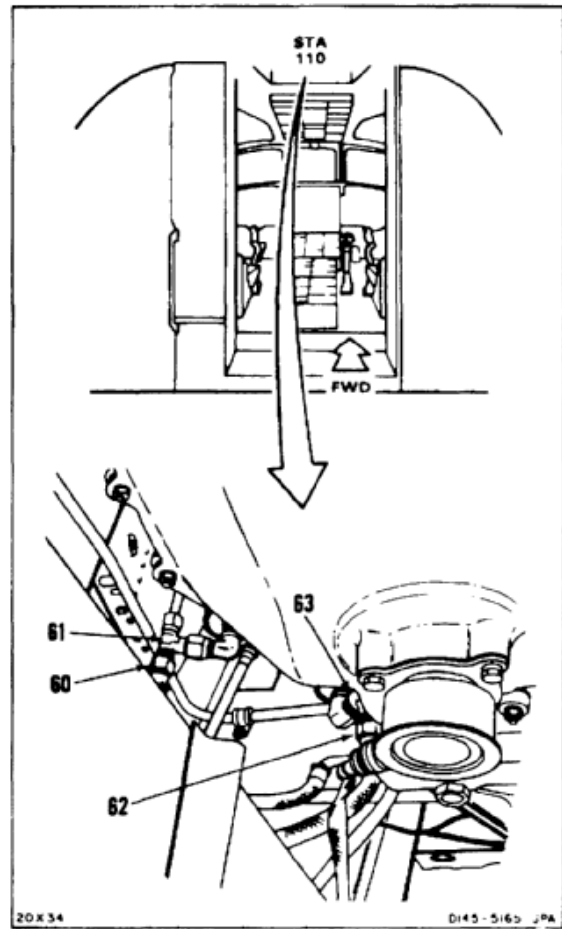
INSPECT**FOLLOW-ON MAINTENANCE:**

- Connect forward pitch links (Task 5-99).
- Bleed flight control hydraulic system (Task 7-16).
- Perform operational check (TM 55-1520-240-T).
- Perform neutral rigging check (Task 11-33).
- Install forward transmission drip pan (Task 2-3).
- Close left forward work platform (Task 2-2).

END OF TASK

INITIAL SETUP

Applicable Configurations:

All

Tools:

Aircraft Mechanic's Tool Kit, NSN 5180-00-323-4692
Torque Wrench, 30 to 150 Inch-Pounds
Torque Wrench, 100 to 750 Inch-Pounds
Torque Wrench, 700 to 1600 Inch-Pounds

Materials:

Antiseize Compound (E75)
Gloves (E184.1)

Parts:

Preformed Packings
Cotter Pins

Personnel Required:

Medium Helicopter Repairer (2)
Inspector

References:

TM 55-1520-240-23P

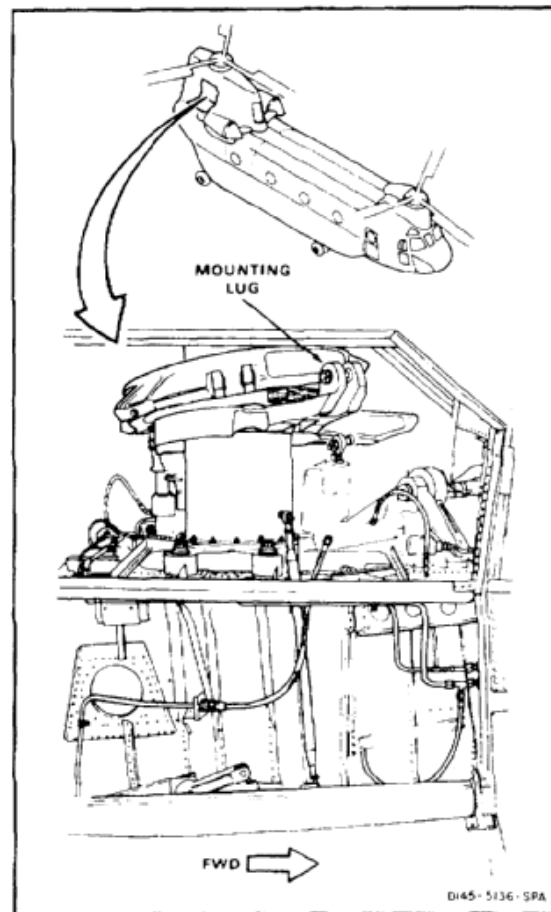

NOTE

All overhauled actuators must have a suffix "N" behind the serial number. (Suffix "N" indicates the actuator has been adjusted in accordance with TB 1-1520-240-20-85, this is not required on new actuators.)

1. Install valve (1) and packing (2) in servocylinder (3).
2. Install valve (4) and packing (5).
3. Install tee (6) and packing (7). Do not tighten nut (8) at this time.
4. Install tee (9) and packing (10). Do not tighten nut (11) at this time.
5. Install elbow (12) and packing (13).
6. Install elbow (14) and packing (15).
7. Slide clamp (16) on servocylinder (3).
8. Slide clamp (17) on servocylinder (3).
9. Connect tube (18) to tee (6), and valve (1). Remove tag.
10. Position clamp (16) on clamp (19). Install screw (20), washer (21), and nut (22). Tighten nut (8).
11. Connect tube (23) to tee (9) and valve (4). Remove tag.
12. Position clamp (17) on clamp (24). Install screw (25), washer (26), and nut (27). Tighten nut (11).

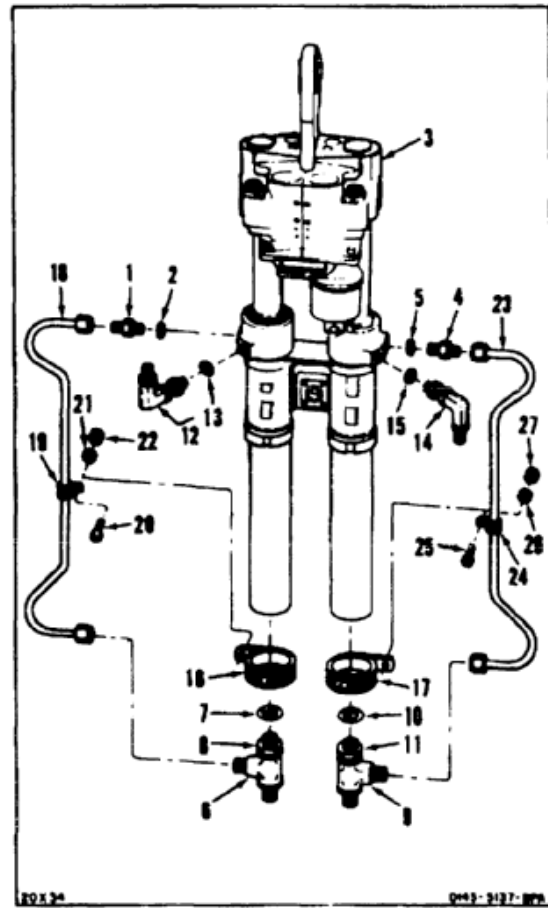

WARNING

Make sure slip bushings are installed in lugs. Otherwise, personal injury, loss of life, or loss of helicopter can result.

13. Check that flanged bushing (28) is installed in inboard lug (29).
14. Have helper on work platform support servocylinder (3). Position mount (30) in lugs (29).

NOTE

Two washers may be installed under nut to allow for cotter pin installation.

Install countersunk washers with countersink against bolthead.

- 14.1. Insert slip bushing (30.1) in outboard lug (29).
- 14.2. While holding bushing (30.1) in position, install bolt (31), with countersunk washer (32) and washer (32.1) through lugs (29). Install one or two washers (32.2) and nut (33) on bolt.
15. Torque nut (33) to **290 to 660 inch-pounds**. Continue tightening only as needed to align cotter pin hole. Do not exceed **1400 inch-pounds**. Install cotter pins (34).
- 15.1. Install inner bushing (37.1) and outer bushing (37.2) in servocylinder (3).
16. Position link (35) in lugs (36). Install bolt (37) with one washer (38) against bushing in lugs. Install second washer (38) and nut (39).
17. Torque nut (39) **30 to 45 inch-pounds**. Install cotter pin (40).
18. Check bolt (37). Bolt shall not rotate with torque less than **10 inch-pounds**. There shall be no axial looseness. If bolt rotates, or is loose, add washer under nut. Torque and cotter pin nut again.
19. Remove block (41) from under swashplate (42).

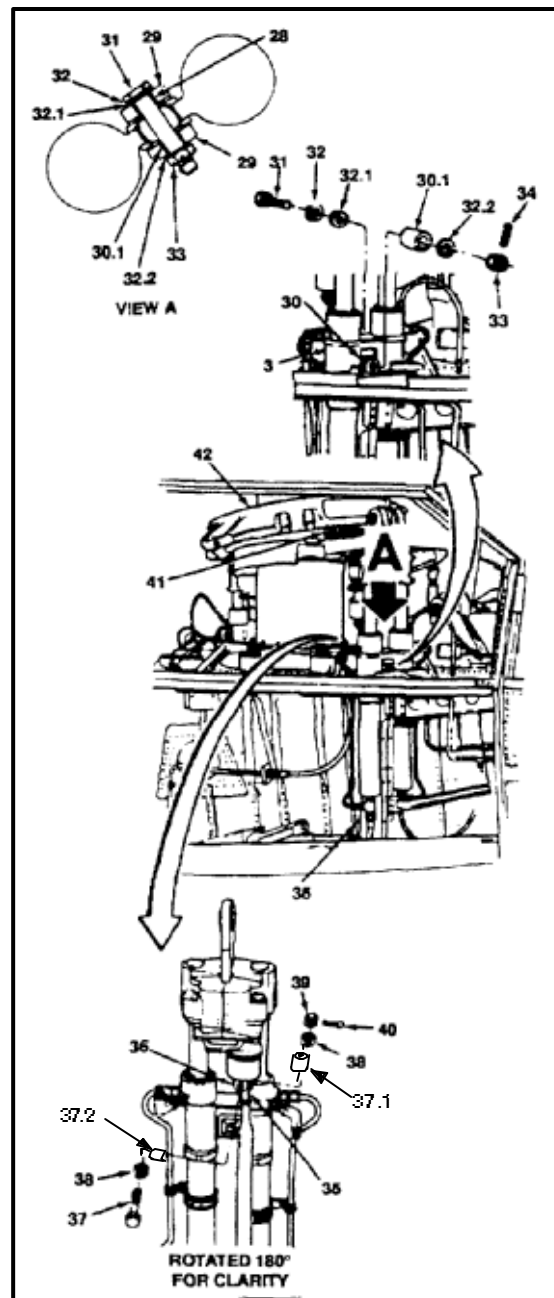

WARNING

Antiseize compound (E75) can irritate skin and cause burns. Avoid contact with skin, eyes, or clothing. In case of contact, immediately flush skin or eyes for at least **15 minutes**. Get medical attention for eyes.

20. Tilt swashplate (42) and position bearing (43) between two lugs (29). Install bolt (44), washer (45), and nut (46). Coat shank of bolt and outside diameter of bushing with antiseize compound (E75). Do not get compound on thread of bolt. Wear gloves (E184.1).
21. Torque nut (46) to **660 to 780 inch-pounds (1400 inch-pounds maximum for cotter pin installation)**. Install cotter pin (47).
- 21.1. Inspect installation (Task 7-123).
22. Connect hose (48) to elbow (12). Remove tag.
23. Connect hose (49) to elbow (14). Remove tag.
24. Connect hose (50) to tee (6). Remove tag.
25. Connect hose (51) to tee (9). Remove tag.

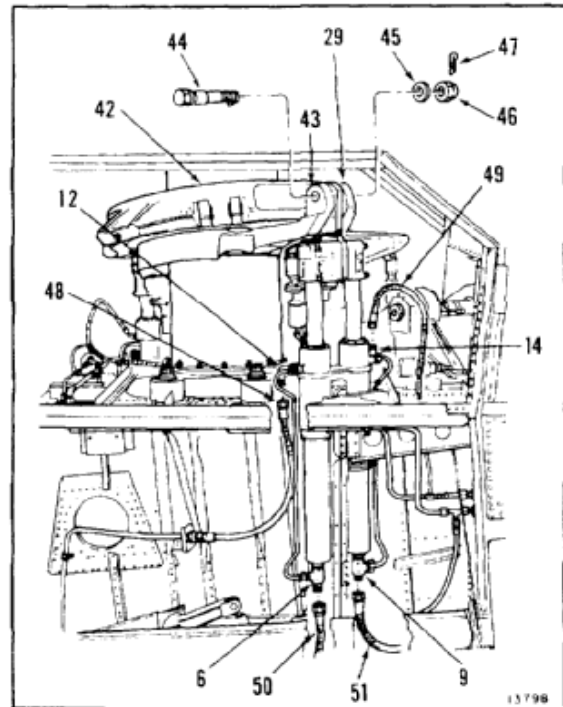
**INSPECT****FOLLOW-ON MAINTENANCE:**

- Connect aft pitch links (Task 5-99).
- Bleed flight control hydraulic system (Task 7-16).
- Perform neutral rigging test (Task 11-33).
- Close right aft work platform (Task 2-2).

END OF TASK

**SECTION III
UTILITY HYDRAULIC SYSTEM
DESCRIPTION
AND
THEORY OF OPERATION**

DESCRIPTION

The utility hydraulic system provides hydraulic pressure to operate seven subsystems throughout the helicopter. The systems are engine start, cargo ramp and door, cargo winch, cargo hook release, power steering and aft swivel locks, and wheel brakes. In addition, the system can be used to pressurize the flight control system during ground checks.

The following components are common to all subsystems:

APU Start Accumulators

This accumulator is used to store hydraulic fluid under pressure to start the APU. It is located in the ramp area to the right of the aft transmission. In an emergency, the pressure in the accumulator can be used to operate the utility subsystems.

APU Start Module

Pressure from the APU start accumulator is released through the APU start module to the APU motorpump when an APU start is called for. The module also signals the APU motorpump to shift from motor mode to pump mode as its rpm increases. The module contains a depressurization valve that is used to repressurize the start accumulator for maintenance.

The start module is located in the ramp area, aft of the APU start accumulator.

APU Motorpump

The motorpump is mechanically coupled to the forward end of the APU. When serving as a motor, it receives hydraulic pressure from the APU start accumulator to drive the APU to starting speed. When the APU starts,

it drives the motorpump as a pump. As a pump, it supplies pressurized hydraulic fluid at **3350 psi** to start the engines or to power the utility subsystems.

The motorpump can also be used to power the utility hydraulic system if the utility pump fails.

Utility Pump

When the engines are running and the rotor system is turning, the entire utility system is pressurized by the utility pump through the pressure control module. The pump is installed on the right side of the aft transmission and is driven by the transmission. It delivers hydraulic fluid to the pressure control module at **3,000 to 3,100 psi**.

Pressure Control Module

The pressure control module receives input hydraulic pressure from the APU motorpump, the utility pump, or an external ground power unit and distributes it to the various utility subsystems. The module is located high in the aft cabin area at sta. 534, to the right of the aft sync shafting.

Return Control Module

This module is the central collection point for all fluid returning from the various subsystems to the reservoir/cooler. A filter and a transfer cylinder are mounted on the module. The filter has a visual contamination indicator and a switch to light a caution light on the maintenance panel in the ramp area. The transfer cylinder supplies fluid to the ramp system to compensate for the additional flow required when the ramp is lowered.

The return module is located high in the aft cabin area at sta. 534, to the left of the aft sync shafting.

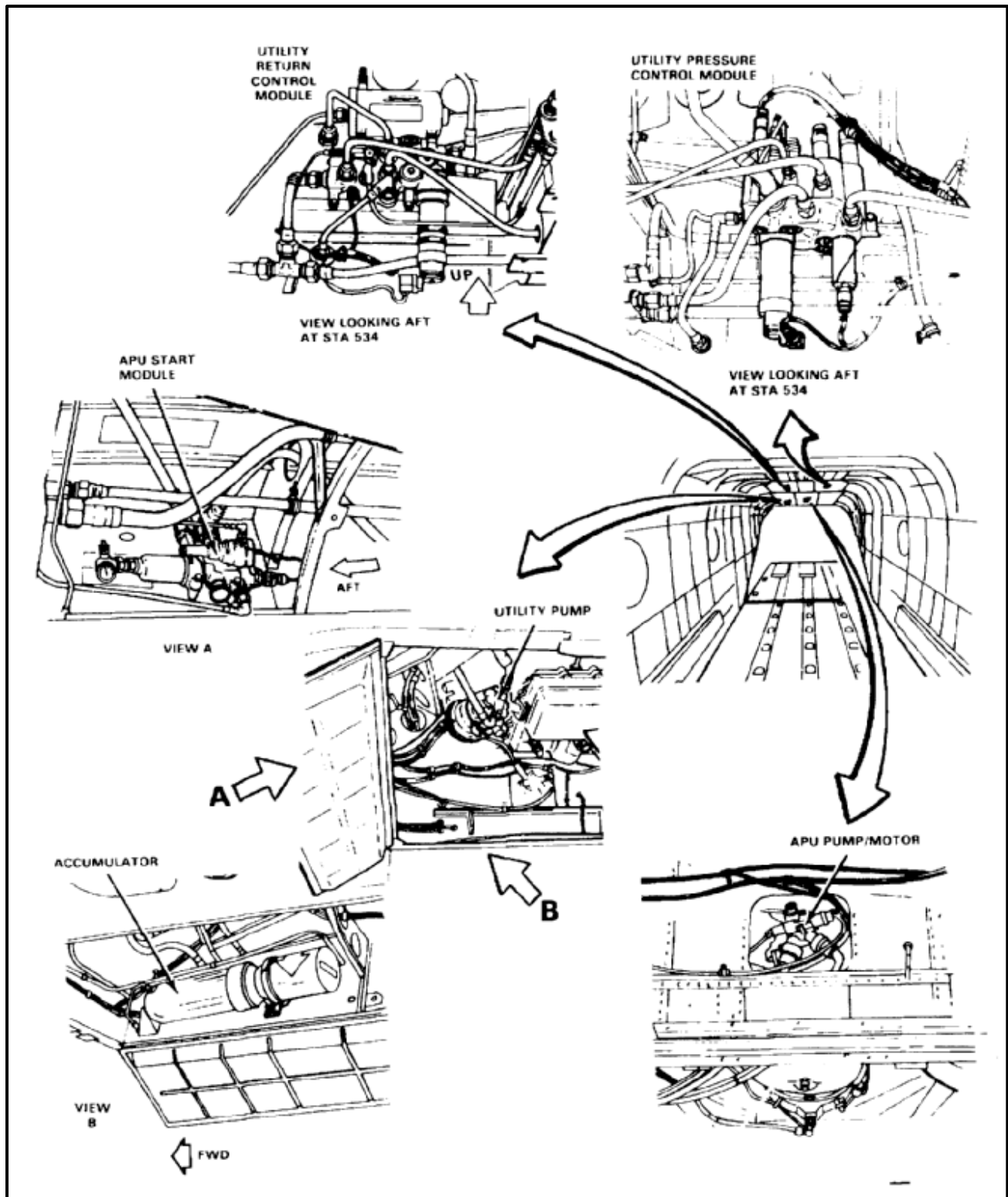

Reservoir/Cooler

A reservoir/cooler module is located in the pylon area on the right side. The reservoir section of the module stores fluid for system operation. The cooler is mounted on top of the reservoir. It is connected by flexible ducting to a fan that is activated by a thermal switch in the cooler. Sensors in the unit send information on fluid temperature to the maintenance panel in the ramp area. An LVDT in the reservoir provides indication of the system fluid level to the maintenance panel.

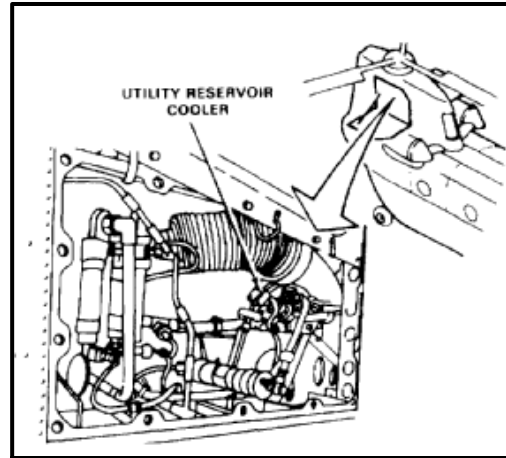

Fill Module

Hydraulic fluid is added to the system through a fill module at the right side of the cabin in the ramp area. The same module is used to fill the utility system and both of the flight control hydraulic systems. Selection of the system to be serviced is by a rotary valve in the module. All hydraulic systems may be serviced either static or while system is operating. Fluid added to the reservoir is pulled through the module and delivered to the return module and reservoir/cooler by operating a small handpump on the module.

Handpump

The handpump is a two-stage manually operated pump located on the right side of the cabin at sta. 527. It is primarily used to pressurize the APU start accumulator to start the APU. In an emergency, it can also be used to pressurize the cargo ramp and door. In an emergency it can be used to pressurize the utility subsystems.

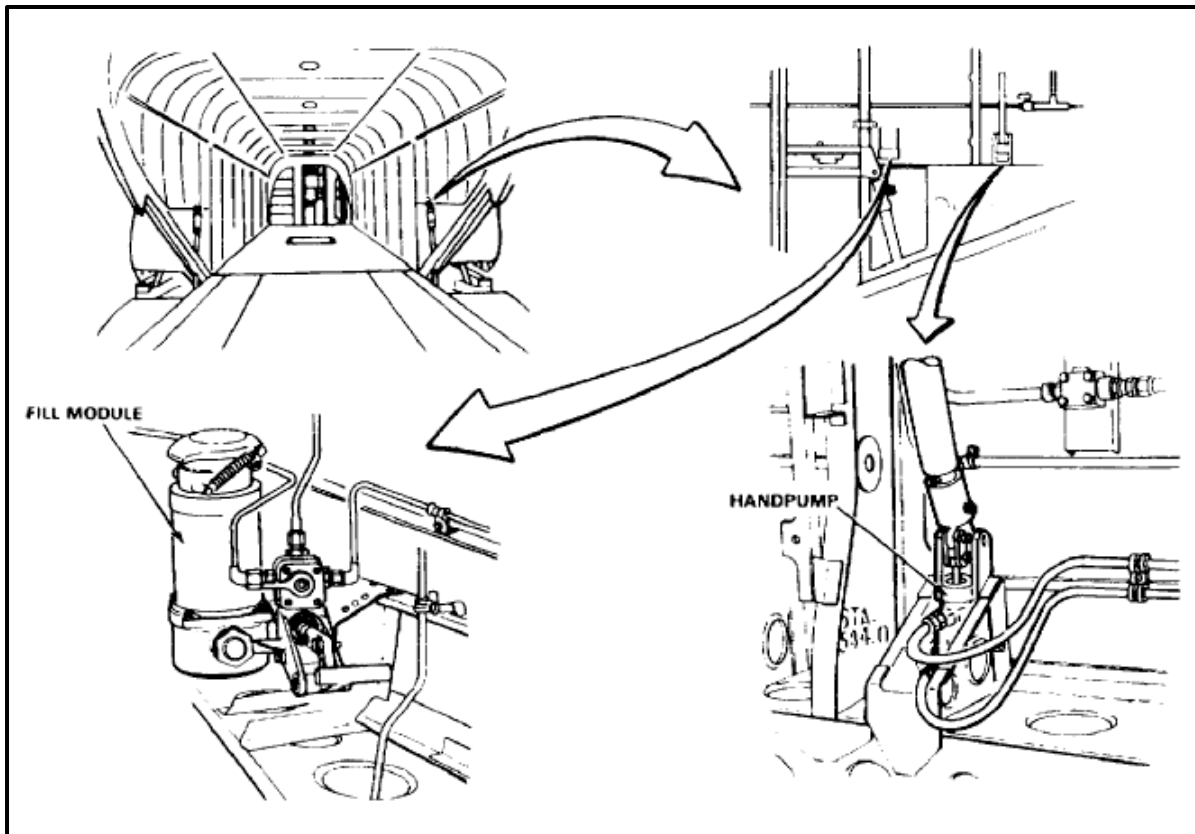

THEORY OF OPERATION

Pressure to operate all utility subsystems comes through the pressure control module. Input to this module is from the utility pump, the APU motorpump, or an external ground power unit.

If the APU is operating, hydraulic power comes from the motorpump. Output from the pump is **3,350 psi**, to ensure enough pressure for engine starting. If the rotors are turning, **3,000 psi** hydraulic pressure becomes available from the utility pump on the aft transmission.

If engines and APU are shut down, **3,000 psi** hydraulic power can be obtained from an external ground power unit through ground service panel connections at the aft right side of the helicopter.

In the control module, pressure is routed through separate ports to the individual subsystems. Solenoid valves on the module allow pressure to individual subsystems to be cut off and the subsystems isolated.

Return fluid from each of the subsystems is routed to a common return control module and through a return filter. It then returns at a pressure of **60 to 90 psi** to the source (utility pump or APU motorpump), by way of the reservoir cooler module. When a standard ground power unit is connected to the utility system, the utility reservoir dumps into the power units reservoir. System operation is then conducted using the power units fluid reservoir. The aircraft's reservoir will then need to be re-serviced prior to disconnecting the ground power unit.

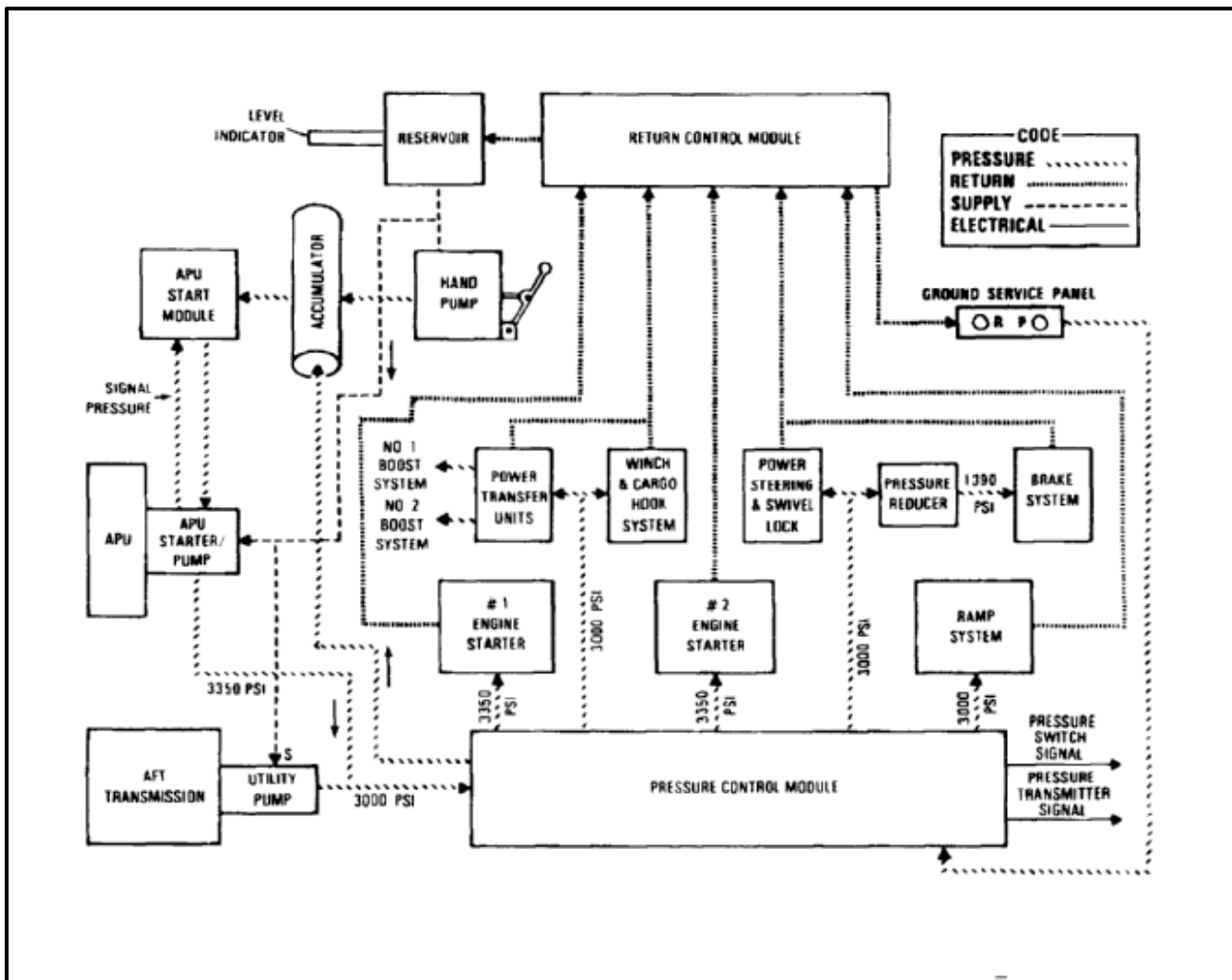

Engine Start System Description

A hydraulic starter is mounted on the front of each engine at the **12 o'clock** position. The starter uses hydraulic pressure from the APU motorpump, the utility pump, or a ground power unit to turn the engine.

The pressure source is coupled to each starter through the utility system pressure control module by a hydraulic pressure line through a coupling at the fuselage quick-disconnect shelf. Return lines run from each engine to the utility hydraulic system return module. An overrunning clutch and an overspeed protector prevent the starter motor from becoming a pump when engine speed exceeds motor speed. The starter shuts off at **50 percent N1**.

Engine starting is controlled by a cockpit switch operating through solenoid (pilot) and pressure-operated (start) valves for each engine. The valves are located in the pressure control module.

Engine Start System Theory of Operation

When the cockpit ENGINE 1 or ENGINE 2 START switch (without **74**) is set to MOTOR or the ENG START switch on the FADEC panel is set to 1 or 2 (with **74**), the associated solenoid pilot valve is energized, allowing hydraulic pressure to flow through the engine start control valve. Both valves are in the pressure control module. The hydraulic pressure may come from one of three sources:

- APU Motorpump (**3,350 psi**)
- Utility Pump (**3,000 psi**) (Emergency Use)
- External Ground Power Unit (**3,350 psi**)

Hydraulic pressure from the control valve turns the hydraulic starter, motoring the engine compressor (N1) section to **18 to 20 percent** to start the engine. As the engine accelerates, an overspeed clutch disengages the starter from the engine and an overspeed protector shuts off the flow of pressurized fluid to the starter. Return fluid from the starter motor is discharged through the return control module to the reservoir cooler.

Cargo Ramp and Door System Description

The ramp is hinged to the fuselage at the floor line and supported by two actuating cylinders. The cylinders are operated by hydraulic fluid through a control valve to raise the ramp. The ramp lowers by gravity, with the actuating cylinders serving as hydraulic dampers.

The ramp can be stopped at any intermediate point on its way up or down and hydraulically locked in position.

A cargo door is an integral part of the ramp assembly. When the ramp is up, the door is fully extended to completely enclose the ramp area of the fuselage.

When it is down, the door retracts into the ramp. Extension and retraction is by a motor inside the ramp

that drives a sprocket and chain assembly. The motor is controlled through a sequence valve that times the doors motion to the position of the ramp. An override valve allows the cargo door to remain open or closed regardless of ramp position.

The ramp system can be isolated from the rest of the utility hydraulic system by a solenoid valve in the utility pressure control module. The normally-open valve is closed through a switch on the overhead HYDRAULIC control panel in the cockpit.

If normal pressure is not available from the utility hydraulic system, the ramp can be operated by pressurizing the system accumulator with the handpump.

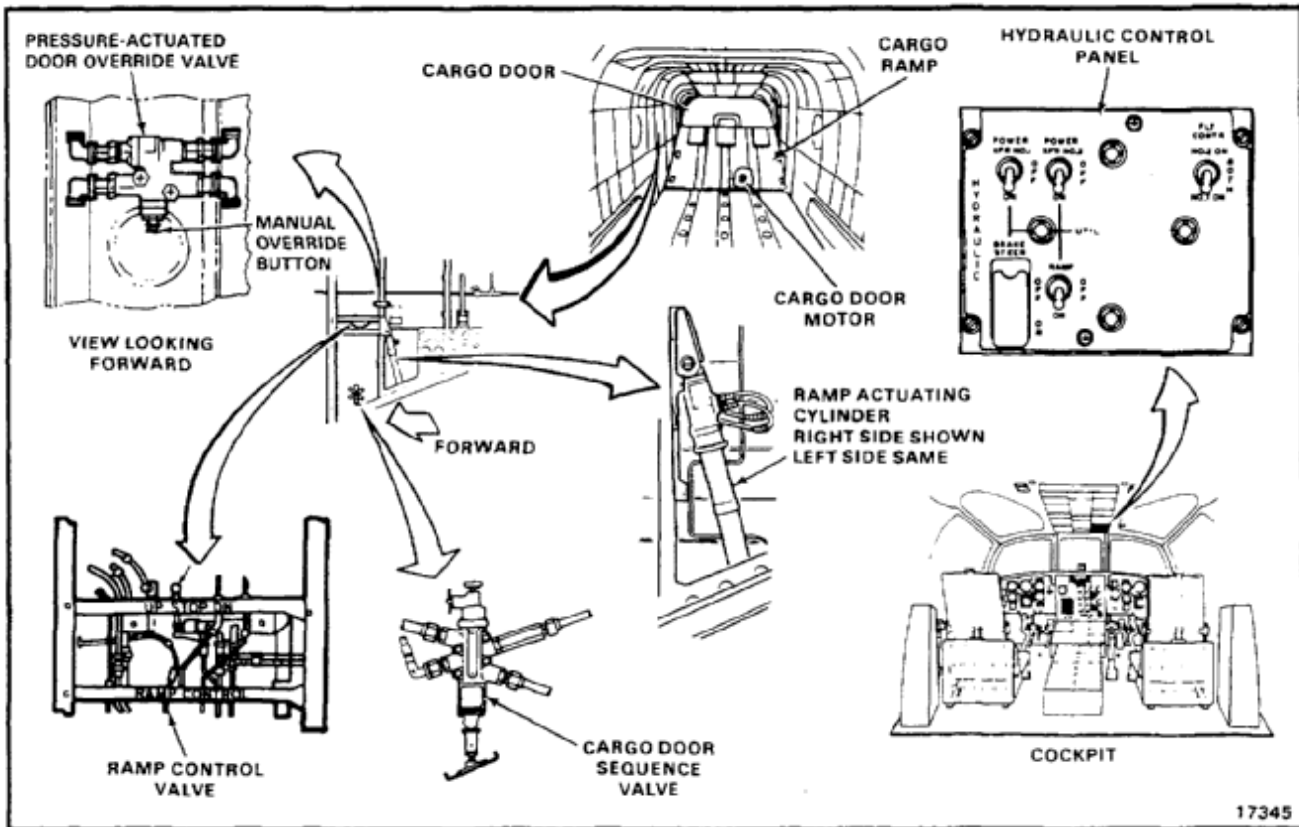

Cargo Ramp and Door System Theory of Operation

NOTE

The following ramp operating and system information is basic and applies to any aircraft equipped with or without **65**. Aircraft equipped with **65** differ in that controls have been provided in the cockpit to operate the ramp control valve in cases of emergency.

When the RAMP switch on the overhead hydraulic (HYD) panel is set to ON, power is removed from a normally-open solenoid valve in the pressure control module. With the solenoid valve open, hydraulic fluid at **3,000 psi**, is allowed to flow to the ramp control valve.

1. When the lever on the control valve is at DN, pressurized fluid releases a mechanical lock in each of the ramp actuating cylinders. As the ramp slowly falls under gravity, fluid is forced out of the cylinders through the pressure actuated valve to the control valve. The control valve routes the fluid to the upper end of the cylinders.

As the ramp falls, the sequence valve is activated by an extending plunger. The valve routes pressurized fluid to the motor in the cargo door, retracting the door into the ramp.

As the door retracts, return fluid from the motor passes through the sequence valve and into the pressure-actuated valve. A relief valve in the pressure-actuated valve boosts the pressure of this return fluid to **180 psi**. This increased pressure moves a spring-loaded valve spool to block the fluid returning from the actuating cylinders, stopping the ramp after it has dropped about **eight inches**.

When the door is fully retracted, the motor stops. This relieves the pressure in the pressure-actuated valve. The valve spool returns to its original position and return flow from the cylinders resumes, allowing the ramp to continue falling.
2. When the lever is moved to UP, fluid is routed by the control valve through the pressure-actuated valve to the bottom of the ramp cylinders. The fluid retracts the cylinders to lift the ramp.

As the ramp rises, it strikes the sequence valve plunger. The valve actuates to allow pressurized fluid to operate the cargo door motor to extend the door.

As the door extends, return fluid from the motor is directed by the sequence valve to the pressure-actuated valve, where it halts the ramp in the same manner as during ramp-down operation.

When the door is fully extended, the motor stops. This relieves the pressure in the pressure-actuated valve. The ramp continues its travel in the same manner as during ramp-down operation.

3. When the lever is moved to STOP, pressurized fluid to the cylinders is cut off and the fluid within them is locked in. The ramp is locked in position.
4. A MANUAL OPER knob and a locking pin on the sequence valve allow the ramp to be raised or lowered with the door locked in position, extended or retracted. When the knob is pushed in and held in place with the locking pin, the valve cuts off fluid flow to the door motor. The position of the door then remains fixed, regardless of ramp movement.
5. Pressing a manual override button at the bottom of the pressure-actuated valve allows the ramp to move continuously instead of stopping while the cargo door retracts or extends.

Emergency Operation of Cargo Ramp and Door System Aircraft Equipped With **65**

The basic cargo ramp and door hydraulic system remains the same. Control from the cockpit is provided by a distinctive HYD panel, **5 second** time delay relay, and ramp control valve peculiar to aircraft equipped with **65**.

RAMP PWR and RAMP EMER switches mounted on the HYD panel control ramp hydraulic power and operation. The RAMP PWR switch is a three position switch with OFF, ON, and EMERG functions. The OFF and ON functions provide the same control as the RAMP switch on aircraft without **65**. When the RAMP PWR switch is set to EMERG, electrical power is directed to the RAMP EMER switch. The RAMP EMER switch is a guarded, momentary double throw switch which controls operation of the ramp control valve.

The **5 second** time delay relay is installed in the overhead panel, and wired between the UP terminal of the RAMP EMER switch and UP solenoid of the ramp control valve. The time delay relay provides a means to keep the ramp traveling downward without having to hold the RAMP EMER switch in the DN position. When the momentary RAMP EMER switch is set to DN, power is directed to the time delay circuit of the relay, while opening the circuit to UP solenoid. Once activated the relay keeps power off the UP solenoid for **5 seconds** while power is supplied to the DN solenoid through the RAMP EMER switch. The time delay relay is energized only in the down (DN) mode and powered by **28 vdc** from the UP side of the RAMP EMER switch.

The ramp control valve on aircraft with **65** is equipped with a slide assembly controlled by a handle or solenoids. The slide assembly is connected to the handle by a detented input piston. Internal UP and DOWN solenoid valves provide control by applying hydraulic inlet pressure to respective ends of the slide assembly. When the solenoid valves are off, pressure is removed from the ends of the slide assembly and the remaining fluid routed to return. When both solenoid valves are off, the ramp control valve is controllable by the handle. When both solenoid valves are energized, pressure is applied to both ends of the slide assembly securing the handle in the STOP position. When either individual DN or UP solenoid valve is energized, the slide assembly and handle are driven into the position directed by the selected valve, therein setting the condition of the ramp control valve.

1. When the RAMP PWR switch is set to EMERG, power from the 28 VDC ESS BUS in the NO. 1 PDP is applied to the RAMP EMER switch. The RAMP EMER switch controls the ramp control valve by distributing power directly to the DN solenoid valve and time delay relay, through which power is supplied to the UP solenoid valve.

NOTE

The RAMP PWR switch must be returned to the ON position if ramp operation is to be controlled from the ramp control valve handle.

With the RAMP EMER switch in the HOLD position, both UP and DN solenoid valves are now energized, with hydraulic pressure applied to both ends of the ramp control valve slide assembly. Hydraulic pressure will restrict movement of the handle and if physically moved to the UP or DOWN position, cause the handle to return to the neutral or STOP position.

2. The ramp is lowered by lifting the RAMP EMER switch guard and moving the switch momentarily to the DN position. The cargo ramp and door will lower in the appropriate sequence, for **5 seconds** and stop from whatever position the ramp is in.

Moving the RAMP EMER switch to the DN position energizes the **5 second** time delay relay. While energized, the relay opens the circuit and removes power from the UP solenoid valve.

With the UP solenoid valve de-energized, hydraulic pressure is released from that end of the slide assembly. Hydraulic pressure from the DN solenoid valve drives the slide assembly and handle into the DN position.

Five seconds after the time delay has been activated, the timing circuit de-energizes the relay. Power is then reapplied to the UP solenoid valve which directs hydraulic pressure to the affected end of the slide assembly. Pressure on the slide assembly from the DN solenoid valve is neutralized, causing the handle to return to the neutral or STOP position.

3. Moving the RAMP EMER switch to the UP position will stop the ramp from being lowered; and if held in the UP position, bring the ramp back up.

When the RAMP EMER switch is moved to the UP position, electrical power is simultaneously applied to the UP solenoid valve and removed from both the time delay relay and DN solenoid valve. Hydraulic pressure directed by the UP solenoid valve causes the slide assembly and handle of the ramp control valve to move to the UP position. The ramp will stop going down and start back up. If the RAMP EMER switch is held in the UP position, the UP solenoid valve will remain energized, causing the door to continue up.

When the RAMP EMER switch is released, power is applied to the DN solenoid valve which directs hydraulic pressure to the down end of the slide assembly. Pressure from the UP solenoid valve is neutralized, causing the slide assembly and handle to return to the neutral or STOP position.

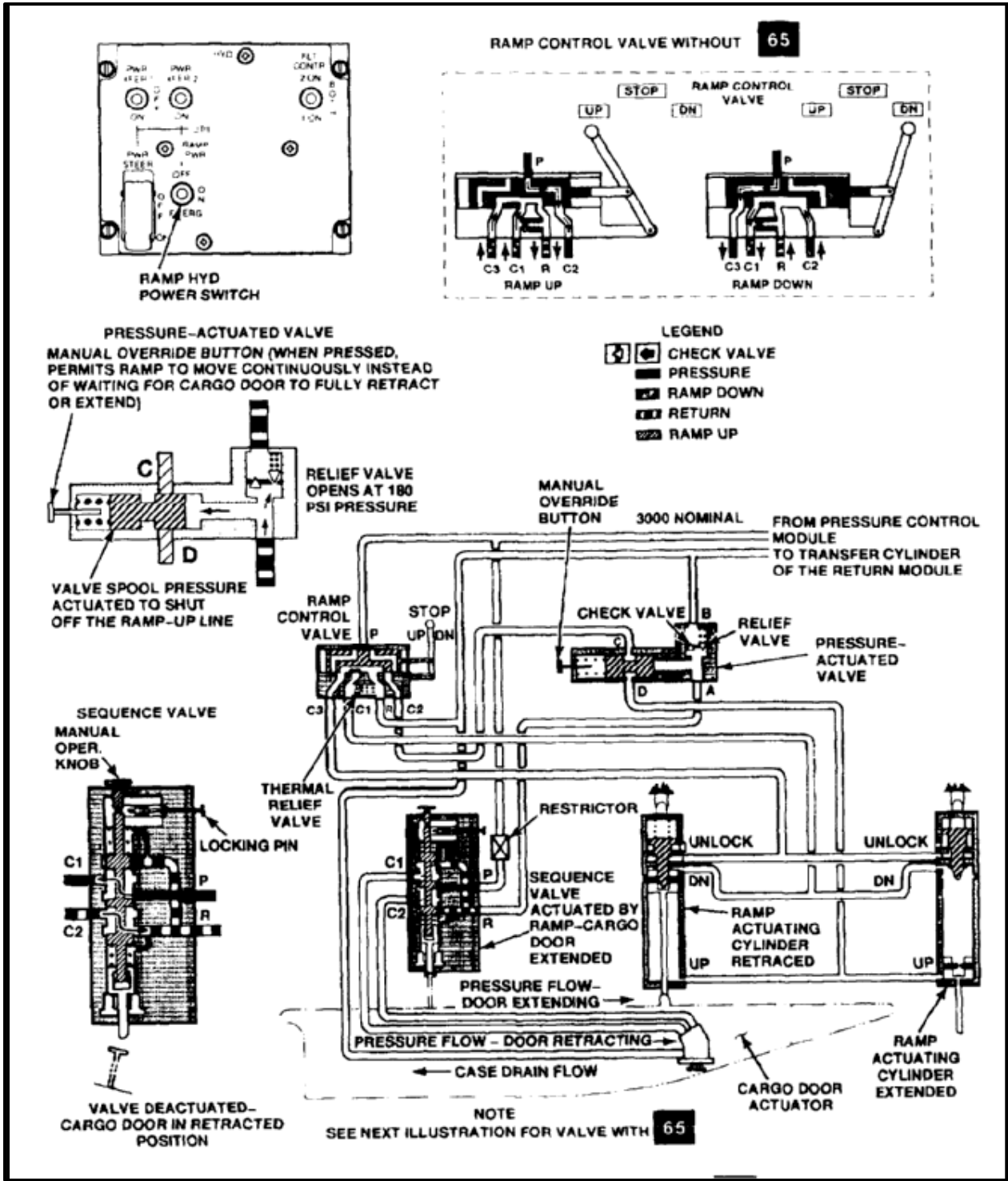

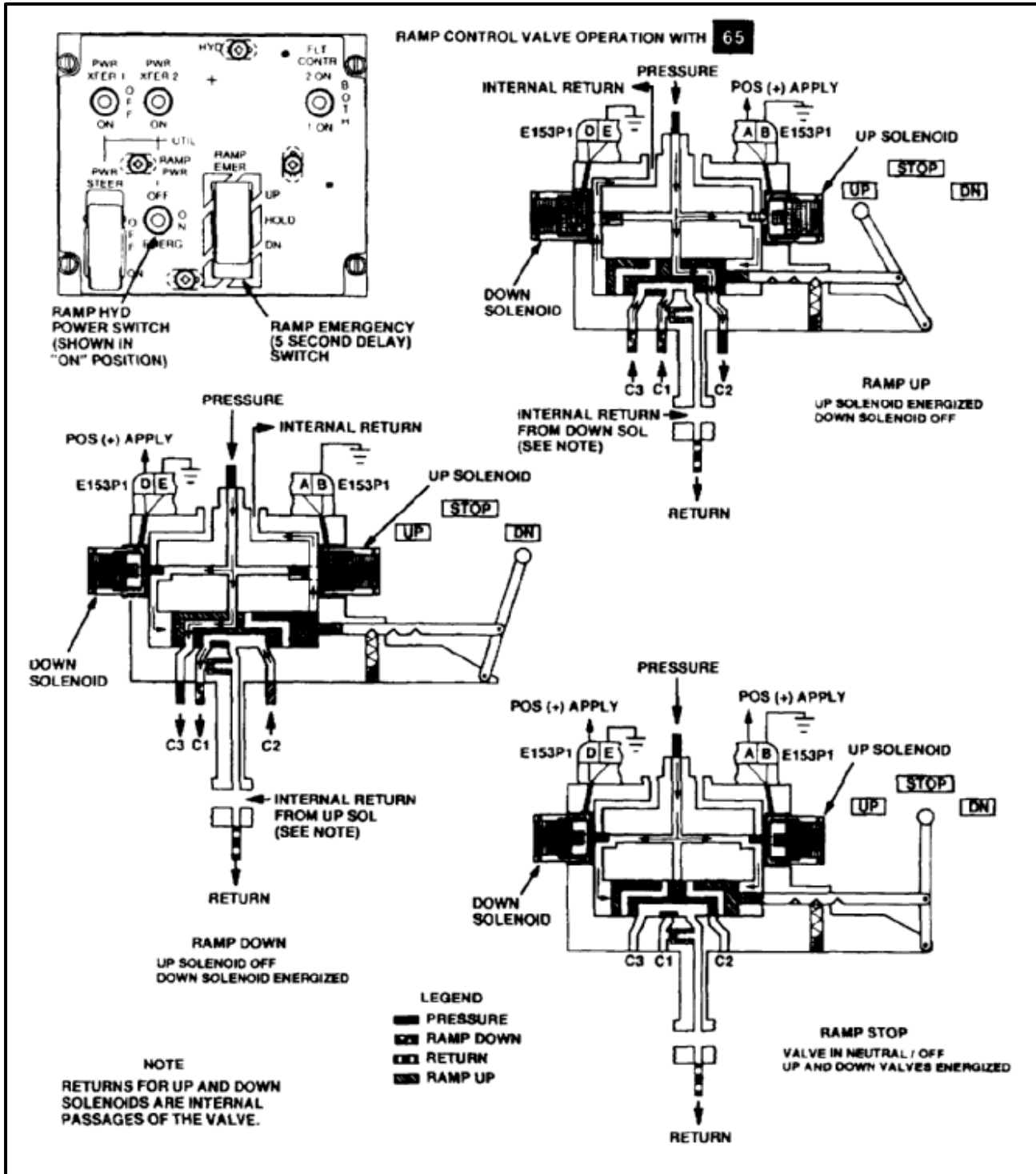

Cargo Hook Release System

The cargo hook hydraulic release system directs hydraulic power to release the center cargo hook. The system consists of a hook release valve and cargo hook actuating cylinder. The hook release valve is located in the tunnel above the cabin at sta. 334. It is a solenoid-operated three-way valve. When the valve is de-energized, fluid pressure is cutoff to the system. When the valve is energized fluid pressure is directed to the hook actuating cylinder which opens the hook. The check valve in the return line prevents loss of system

fluid in the utility system if a line to the cargo hook is broken.

Power Steering System

Refer to Task 7-290.

Swivel Lock System

Refer to Task 7-290.

Cargo Hoist System

Refer to Task 14-1.

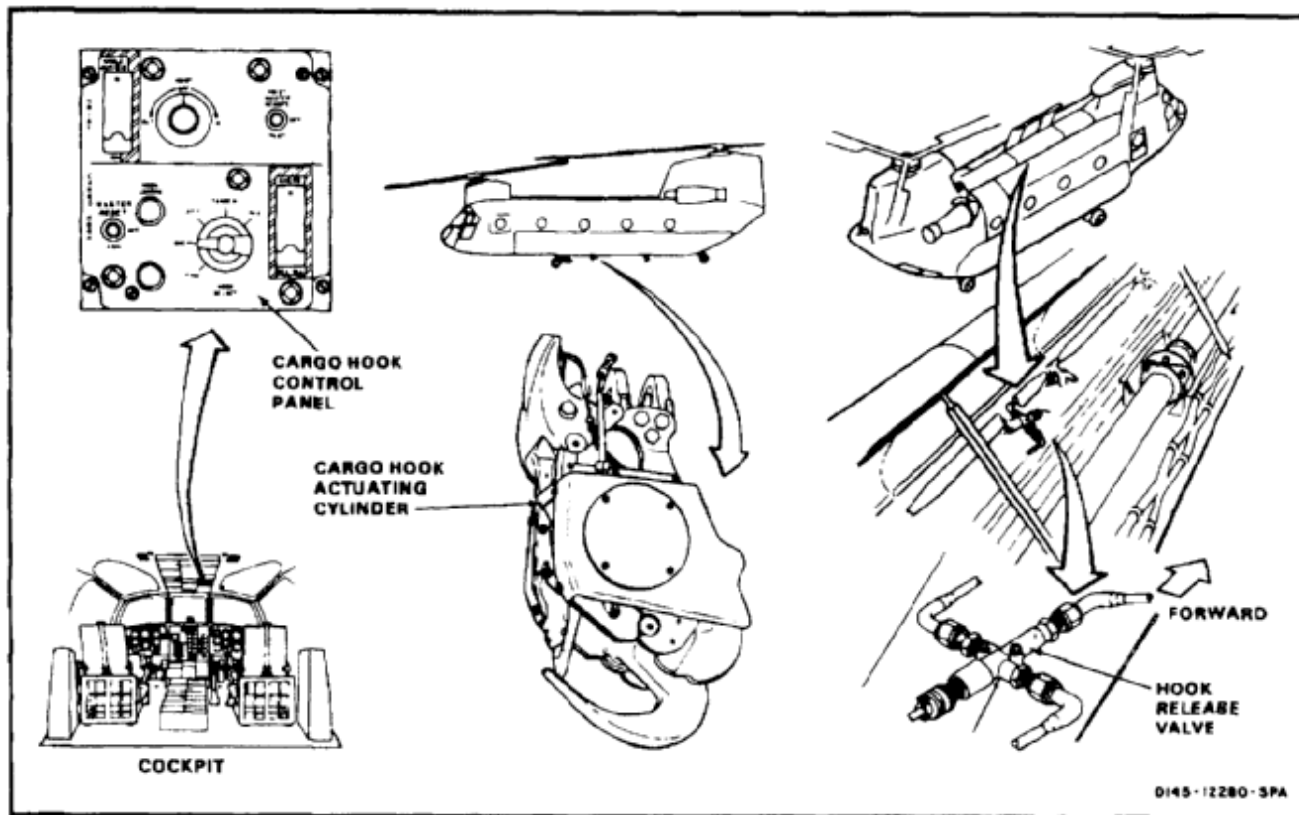

Wheel Brake System Description

The helicopter is fitted with a power-assisted self-adjusting disk brake assembly at each of the four forward and two aft wheels.

The pilot and copilot each have two brake pedals, mounted on the toe of the yaw pedals. The left and right pedals operate the brakes on the corresponding side of the helicopter. Braking on all wheels is obtained when either pilot or copilot presses both pedals.

Each pedal operates its own master cylinder with its own pressure supply. Transfer valves in the left and right system combine pilot and copilot brake input to the corresponding brakes.

A parking brake valve allows the brakes to be set and held on by keeping the lines between the valve and the

brakes pressurized. The valve is actuated by a cockpit parking brake handle. When the handle is pulled out, a light on the master caution panel comes on to warn that the brakes are on.

The brake master cylinders are at the base of their corresponding brake (yaw) pedals. The transfer valves and the parking brake valve are located in the nose left of the forward transmission maintains system pressure. It has enough reserve to allow several power-assisted stops if system pressure is cut off. In case of a failure in the utility hydraulic system, the wheel brake system can be isolated from the failure by closing a solenoid valve in the pressure control module. The valve is closed by a switch on the overhead HYDRAULIC panel in the cockpit.

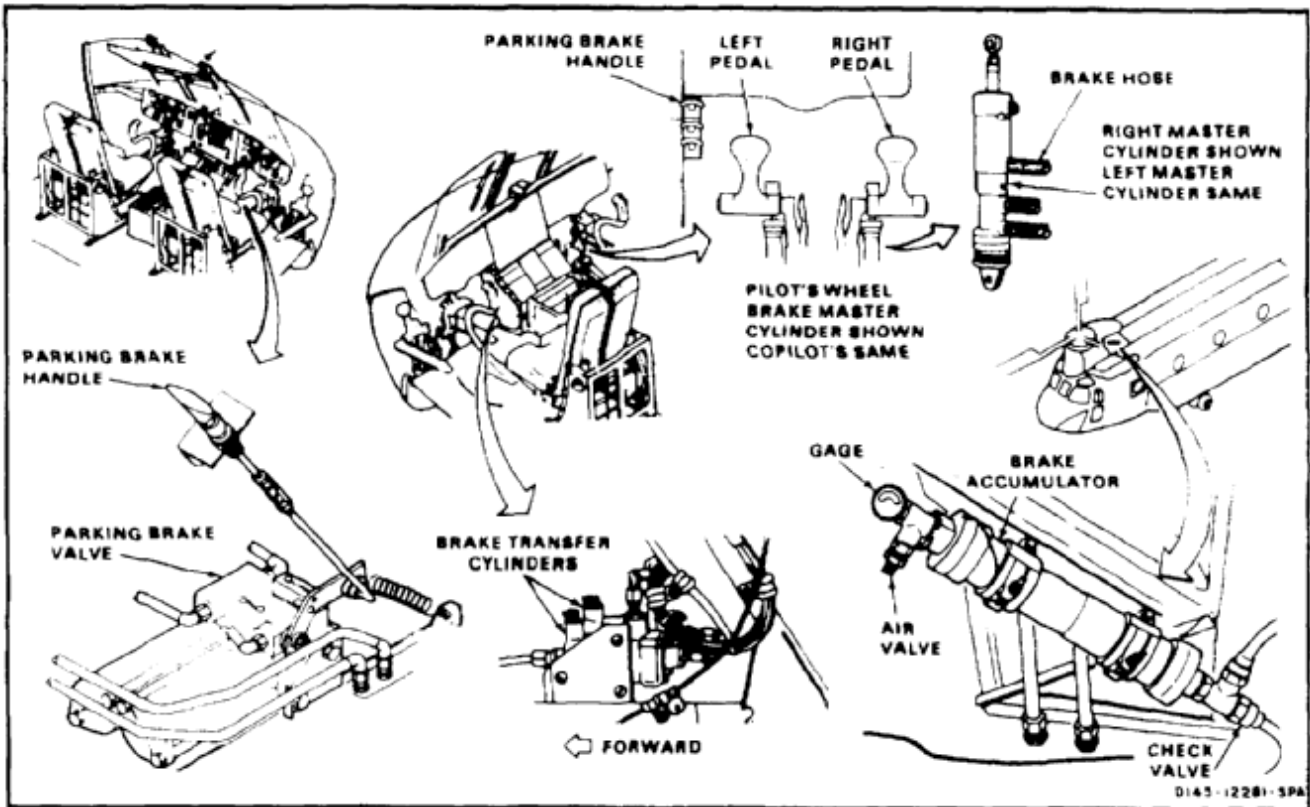

Wheel Brake System Theory of Operation

Hydraulic fluid at a pressure of **3,000 psi** from the utility system pressure control module is reduced to **1,390 psi** in a pressure reducer at sta. 502 left side. The fluid continues through a check valve to a **25 cubic inch** accumulator. The check valve prevents the brake system from being depleted in case of utility system failure.

Fluid from the accumulator enters the four brake cylinders. Two transfer valves combine the pressure output from the cylinders into one line for the left brakes and one line from the right brakes. The two lines enter a parking brake valve. When the brake pedals are pressed, fluid under pressure flows through the valves into each brake assembly. Within each assembly, the

pressurized fluid presses three floating pads against a disk that rotates with the wheel. The floating pads press the rotating disk against three fixed pads on the opposite side of the disk. When the pedals are pressed and the cockpit parking brake handle is pulled, pressurized fluid is trapped between the parking brake valve and the brakes. The valve keeps the brakes engaged by holding pressure against the brake disks. Pulling the brake handle also activates a microswitch on the parking brake valve that lights a **PARK BRAKE ON** light on the master caution panel.

When pressure against the brakes is released, fluid returns through the brake cylinders and past a check valve into the utility system return control module.

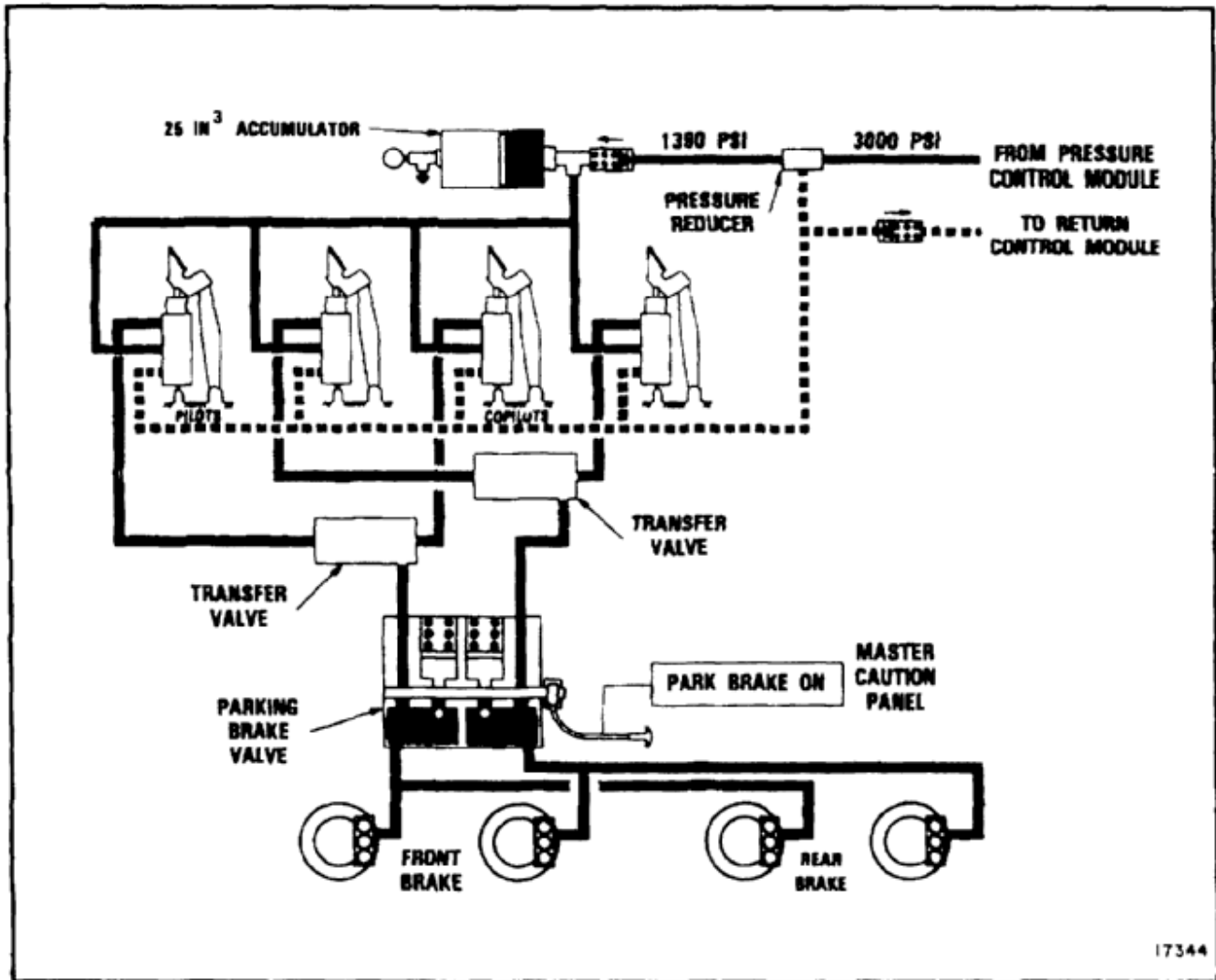

END OF TASK

INITIAL SETUP

Applicable Configurations:

All

Tools:

Aircraft Mechanic's Tool Kit, NSN 5180-00-323-4692

Materials:

None

Personnel Required:

Medium Helicopter Repairer

Equipment Condition:

Battery Disconnected (Task 1-39)

Electrical Power Off

Hydraulic Power Off

Cargo Ramp Open and Level (TM 55-1520-240-T)

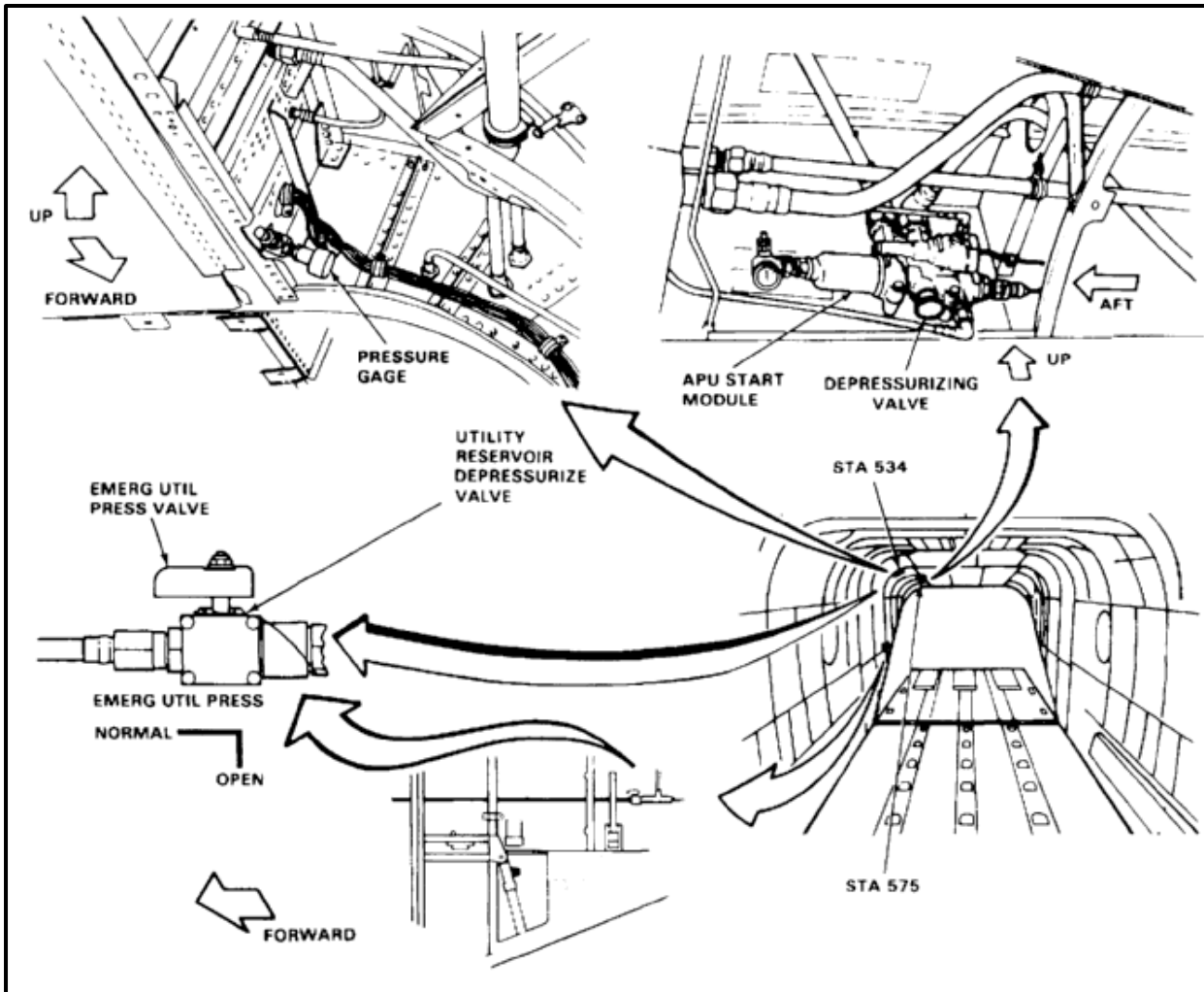

7-135.1 DEPRESSURIZE UTILITY HYDRAULIC SYSTEM (Continued)

7-135.1

1. Turn EMERG UTIL PRESS valve handle (1) and UTILITY RESERVOIR DEPRESSURIZE VALVE handle (1.1) to OPEN.

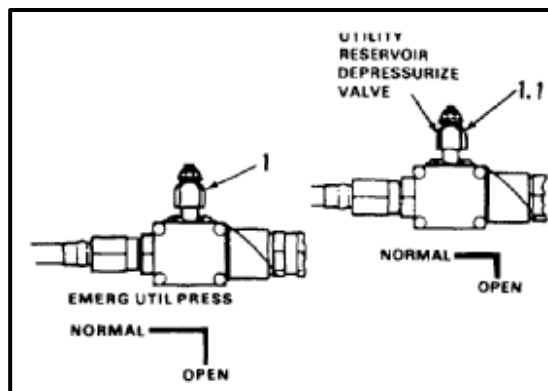

2. Press depressurizing valve (2) on APU start module. Hold valve until sound of repressurizing stops.
3. Deleted.

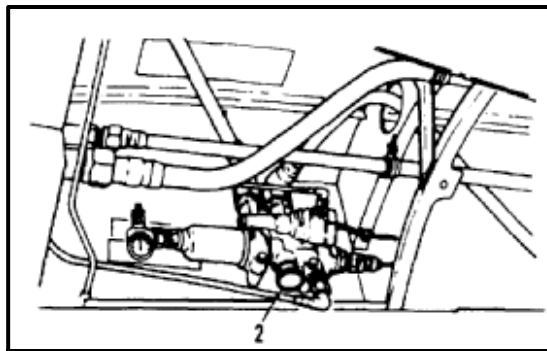

4. Check pressure gage (3). If indicated pressure is less than **1800 psi**, go to Follow-On Maintenance. If not, repeat step 2.

FOLLOW-ON MAINTENANCE:

None

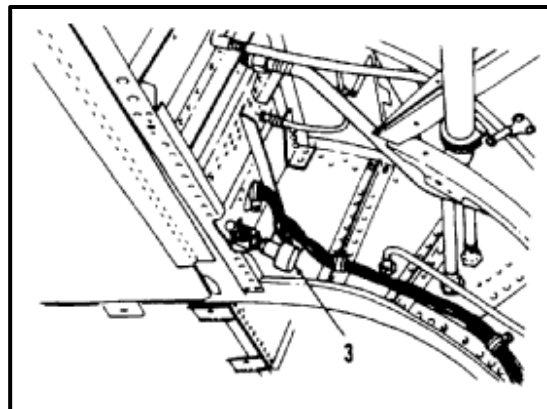

END OF TASK

SECTION IV
UTILITY HYDRAULIC SYSTEM

INITIAL SETUP

Applicable Configurations:

All

Tools:

Aircraft Mechanic's Tool Kit, NSN 5180-00-323-4692

Materials:

Cloths (E135)

Personnel Required:

Medium Helicopter Repairer

Equipment Condition:

Battery Disconnected (Task 1-39)

Electrical Power Off

Hydraulic Power Off

Utility Hydraulic System Depressurized (Task 7-135.1)

Cargo Ramp Open and Level (TM 55-1520-240-T)

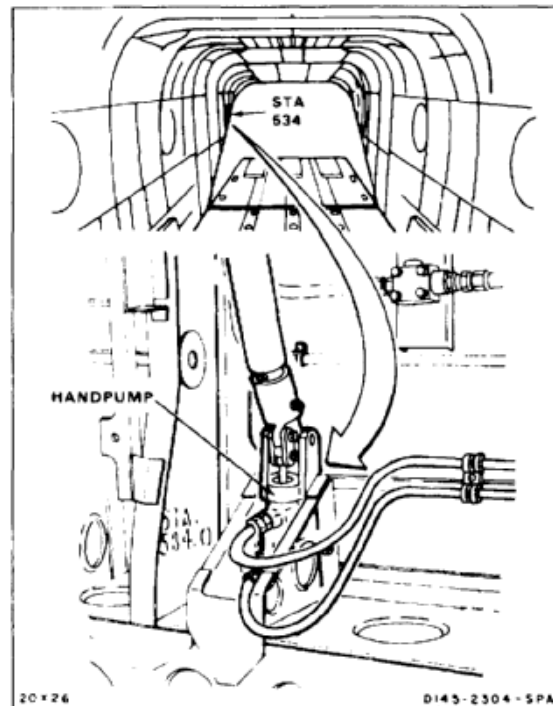

1. Disconnect two tubes (1) from pump (2). Use cloths (E135) for spilled fluid.
2. Remove two nuts (3), four washers (4), and two bolts (5).
3. Remove pump (2).

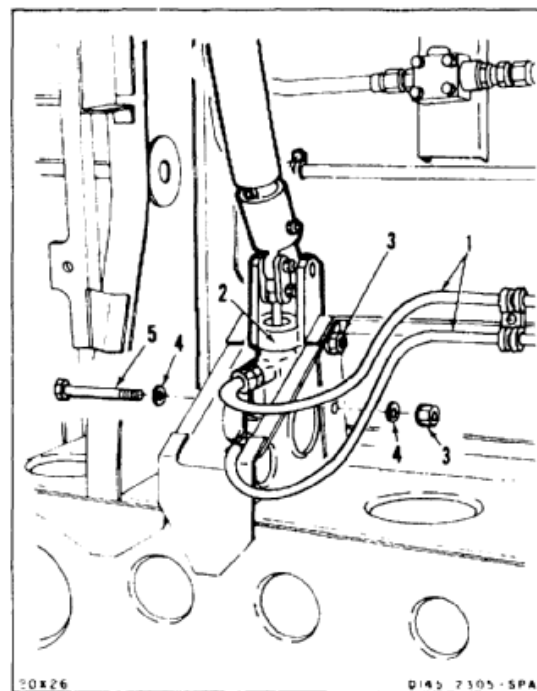

7-136 REMOVE HANDPUMP (Continued)

7-136

4. Remove nut (6), two washers (7), and bolt (8) from handle (9).
5. Remove handle (9) from pump (2).
6. Remove check valve (10), nipple (11), and packings (12).

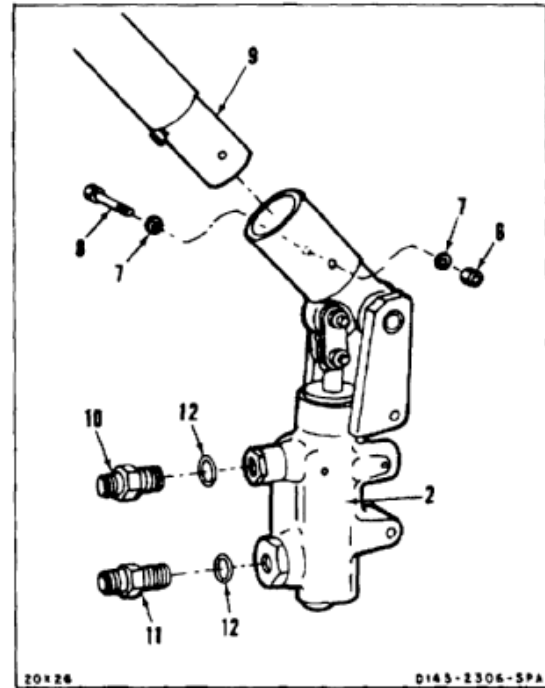
***FOLLOW-ON MAINTENANCE:***

None

Tasks 7-137, 7-138, and 7-139 have been deleted.

END OF TASK

INITIAL SETUP

Applicable Configurations:

All

Tools:

Aircraft Mechanic's Tool Kit, NSN 5180-00-323-4692

Materials:

Cloths (E135)

Parts:

Preformed Packings

Personnel Required:

Medium Helicopter Repairer
Inspector

References:

TM 55-1520-240-23P

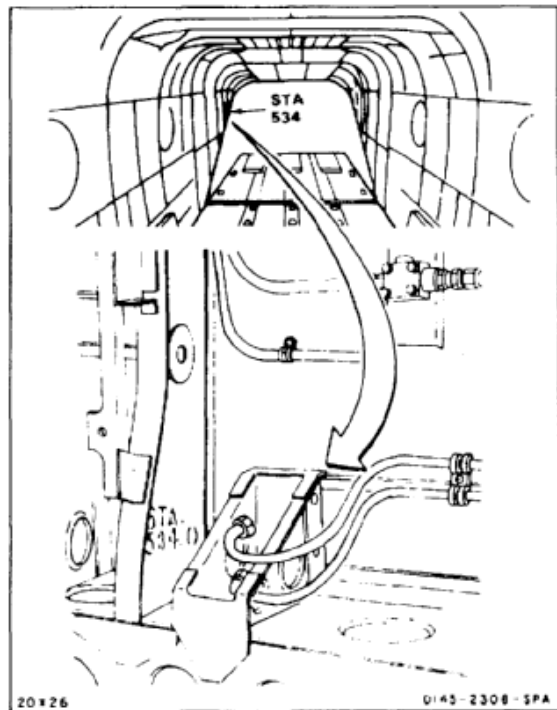

1. Install nipple (1) and packing (2) in SUCTION port (3).
2. Install check valve (4) and packing (5) in PRESS port (6).
3. Install handle (7) in socket (8). Install bolt (9), two washers (10), and nut (11).

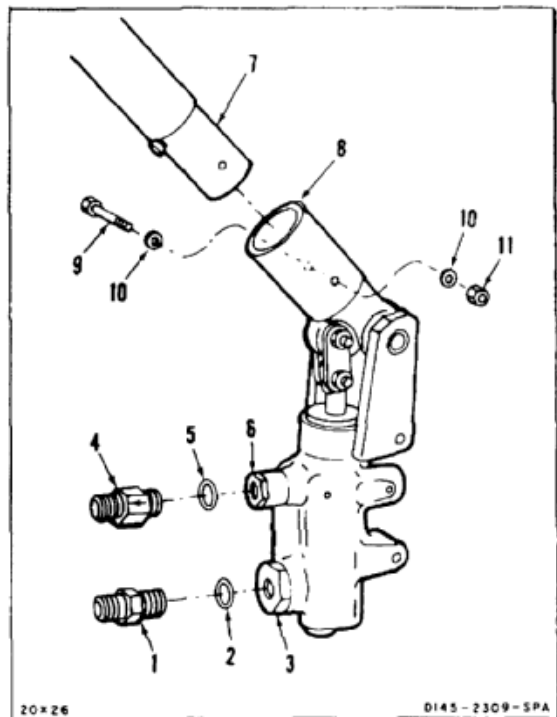

7-140 INSTALL HANDPUMP (Continued)

7-140

4. Position pump (12) in bracket (13).
5. Install two bolts (14), four washers (15), and two nuts (16).
6. Connect tube (17) to nipple (1).
7. Connect tube (18) to check valve (4).

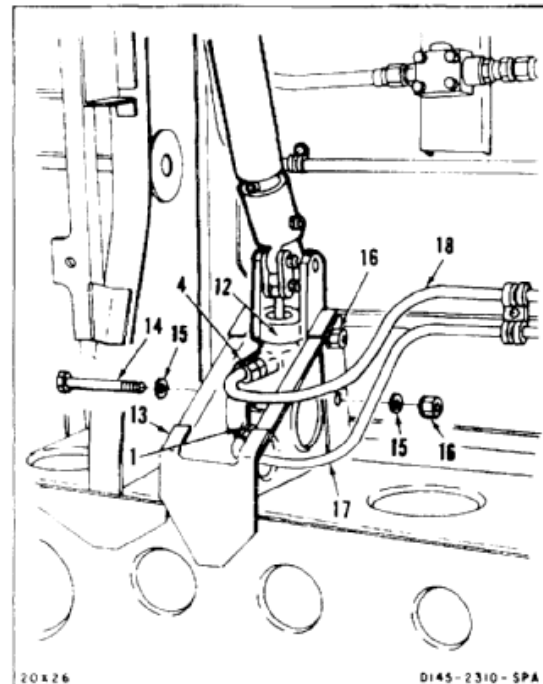
***FOLLOW-ON MAINTENANCE:***

- Bleed utility pump system (Task 7-336).
- Close cargo ramp (TM 55-1520-240-T).

END OF TASK

7-140.1 REMOVE HANDPUMP HANDLE

7-140.1

INITIAL SETUP

Applicable Configurations:

All

Tools:

Aircraft Mechanic's Tool Kit, NSN 5180-00-323-4692

Materials:

None

Parts:

None

Personnel Required:

Medium Helicopter Repairer

Equipment Conditions:

Battery Disconnected (Task 1-39)
 Electrical Power Off
 Hydraulic Power Off
 Utility Hydraulic System Depressurized (Task 7-135.1)
 Cargo Ramp Open and Level (TM 55-1520-240-T)

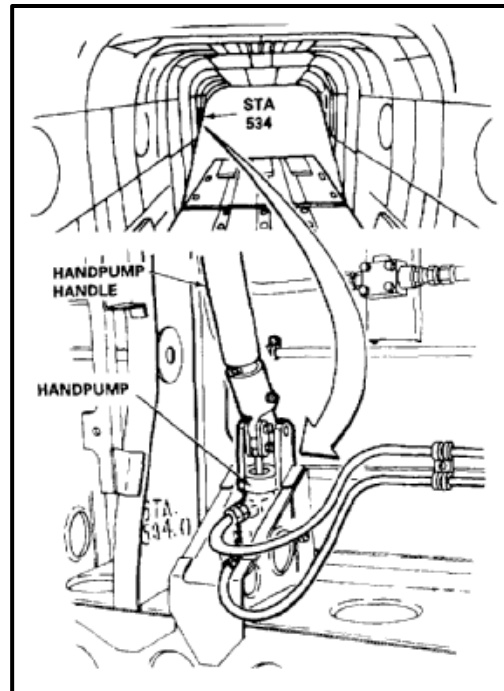

1. Remove nut (1), two washers (2), and bolt (3), from handle (4).
2. Remove handle (4) from pump (5).

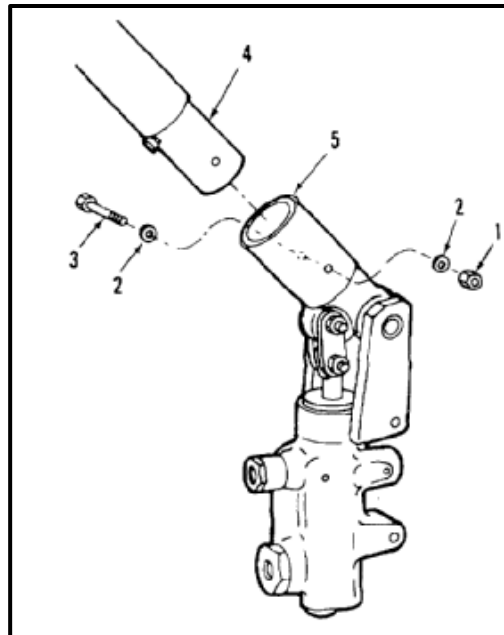
**FOLLOW-ON MAINTENANCE:**

None

END OF TASK

7-630

7-140.2 DISASSEMBLE HANDPUMP HANDLE

7-140.2

INITIAL SETUP**Applicable Configurations:**

All

Tools:

Aircraft Mechanic's Tool Kit, NSN 5180-00-323-4612
 Socket Handle, 1/4 Inch Drive
 Adapter with 3/32 Inch Allen
 Wrench

Materials:

None

Parts:

None

Personnel Required:

Medium Helicopter Repairer

References:

TM 55-1520-240-23P

Equipment Conditions:

Off Helicopter Task

1. Remove cap screw (1) from tube assembly (2).
2. Depress button (3) and slide outer-tube (4), toward pump-end of inner-tube (5), causing inner-tube (5) to bump against cap (6).
3. Repeat several times until cap (6), comes off outer-tube (4).

NOTE

Outer-tube (5) cannot be removed
 until retainer is removed.

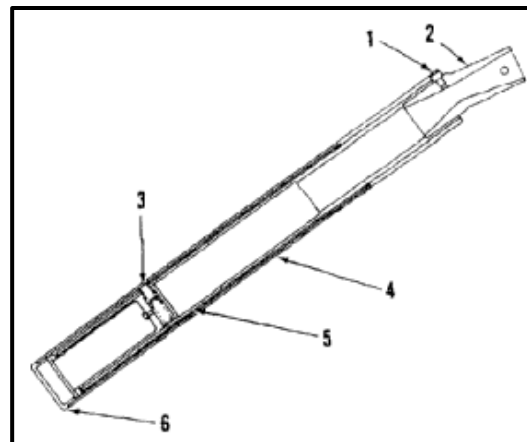
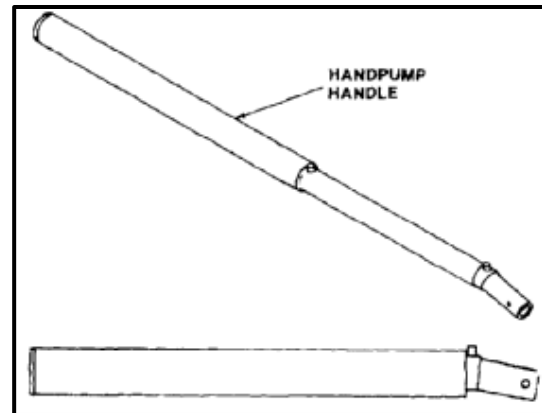

4. Remove $3/32$ inch cap screw (7).
5. Slide outer-tube (5), until button (3) is exposed (pops up).
6. Depress button (3), compressing spring (8), so that button (3) is below hole in retainer (9).
7. Rotate retainer (9) to keep button (3) from popping up.
8. Slide outer-tube (5) down exposing top of retainer (9).



Depressed spring may pop out causing injury.

9. Carefully slide retainer (9) out cap end (10) of handle (2).
10. Remove spring (8) and button (3).
11. Remove outer tube (4) from inner tube (5).

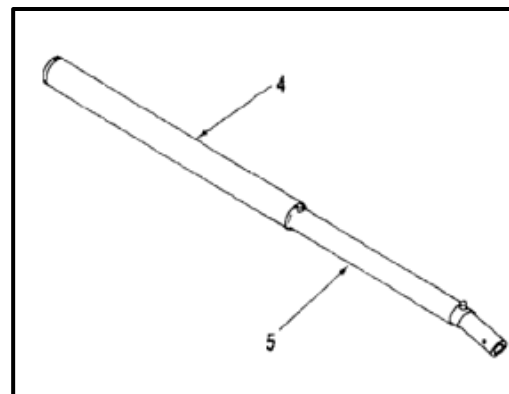
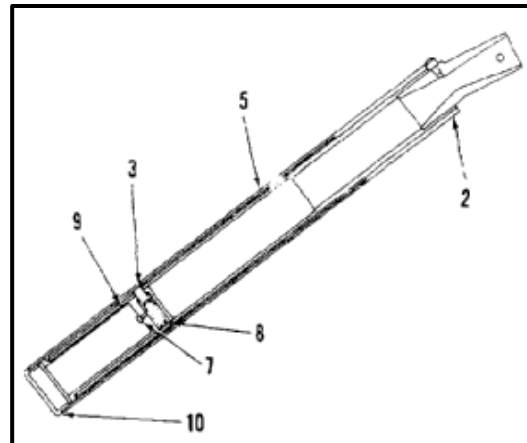

FOLLOW-ON MAINTENANCE:

None

END OF TASK

7-632

7-140.3 ASSEMBLE HANDPUMP HANDLE

7-140.3

INITIAL SETUP**Applicable Configurations:**

All

Tools:

Aircraft Mechanic's Tool Kit, NSN 5180-00-323-4692
 Soft Jawed Vise
 Socket Handle, 1/4 Inch Drive
 Adapter with 3/32 Inch Allen
 Wrench

Materials:

None

Parts:

Spring
 Button

Personnel Required:

Medium Helicopter Repairer
 Inspector

References:

TM 55-1520-240-23P

Equipment Conditions:

Off Helicopter Task

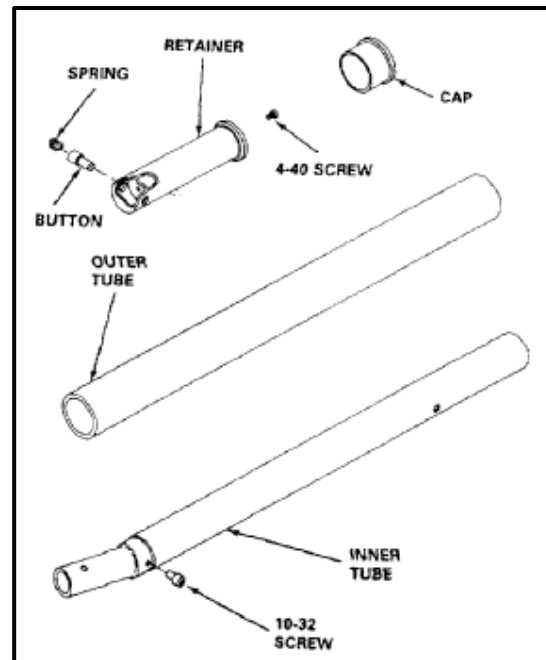

1. Slide outer-tube (1) over inner-tube (2).
2. Insert spring (3) into bottom recess of button (4) and insert into retainer (5) keeping spring (3) compressed.
3. Slide retainer (5) into inner-tube (2), releasing spring (3), once inside inner-tube (2).
4. Twist retainer (5) until button (4) pops up through hole in inner-tube (2).
5. Install cap screw (6) inside retainer (5), to secure spring (3) and button (4).

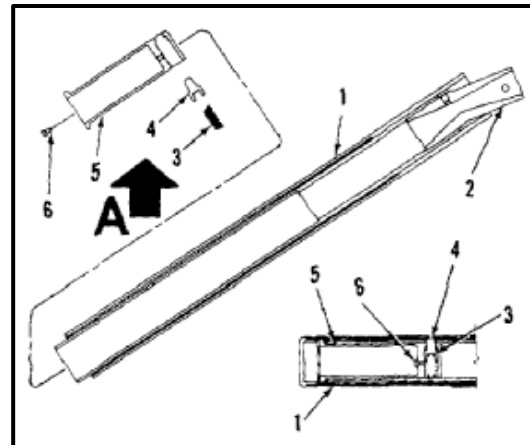

6. Slide outer-tube (1) to extended position. Button (4) will pop up.
7. Place handle in vise (7).
8. Install cap (8) on end of outer-tube (1). Tap in place.
9. Install cap screw (9) on pump end of inner-tube (10).
10. Remove pump handle assembly (11) from vise (7).

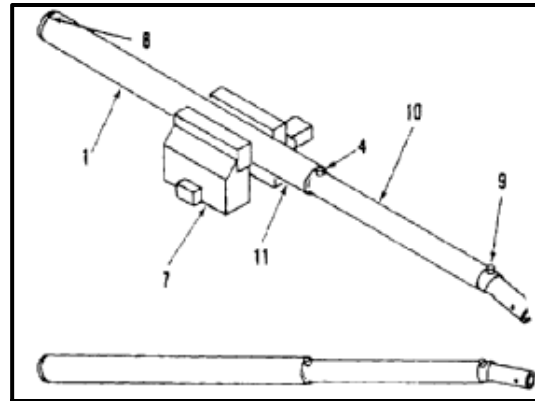
INSPECT**FOLLOW-ON MAINTENANCE:**

None

END OF TASK

7-634

7-140.4 INSTALL HANDPUMP HANDLE

7-140.4

INITIAL SETUP**Applicable Configurations:**

All

Tools:

Aircraft Mechanic's Tool Kit, NSN 5180-00-323-4692

Materials:

None

Parts:

None

Personnel Required:Medium Helicopter Repairer
Inspector**References:**

TM 55-1520-240-23P

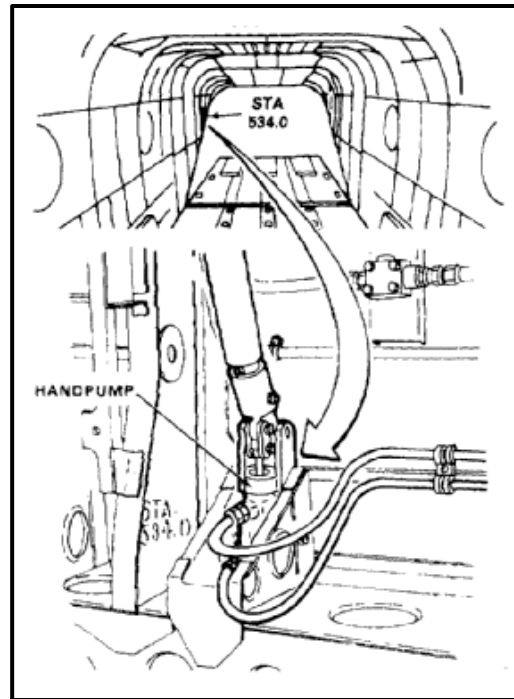

1. Install handle (1) in socket (2) of pump (3).
2. Install bolt (4) and one washer (5) through socket (2).
3. Install one washer (5) and nut (6). Tighten nut (6).

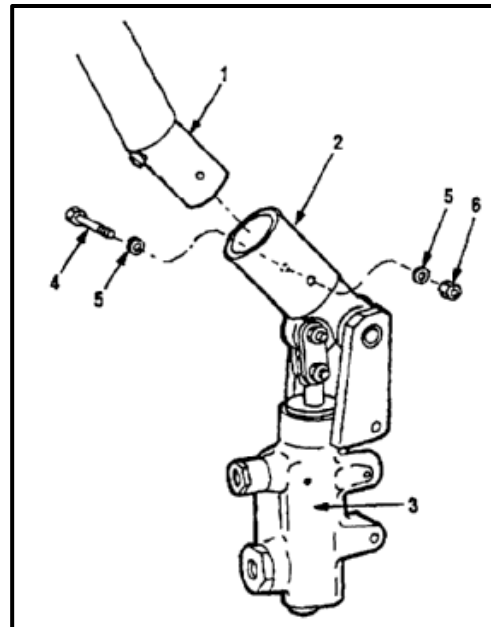
INSPECT**FOLLOW-ON MAINTENANCE:**

None

END OF TASK

INITIAL SETUP

Applicable Configurations:

All

Tools:

Aircraft Mechanic's Tool Kit, NSN 5180-00-323-4692
Container, 2 Quart

Materials:

Cloths (E135)
Paper Tags (E264)

Personnel Required:

Medium Helicopter Repairer

Equipment Condition:

Battery Disconnected (Task 1-36)
Electrical Power Off
Hydraulic Power Off
Engine Access Cover Open (Task 4-49)

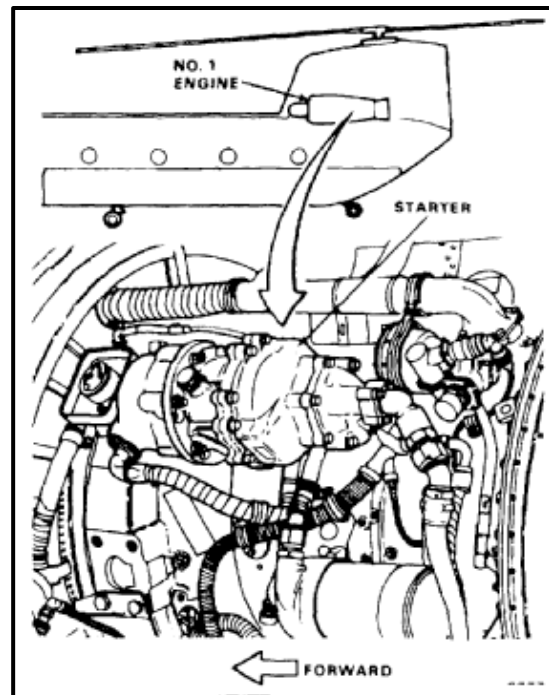

NOTE

Procedure is same to remove No. 1 or No. 2 starter. Removal of No. 1 engine starter is shown here.

1. Tag and disconnect three hoses (1) from starter (2). Use cloths (E135) for spilled fluid.

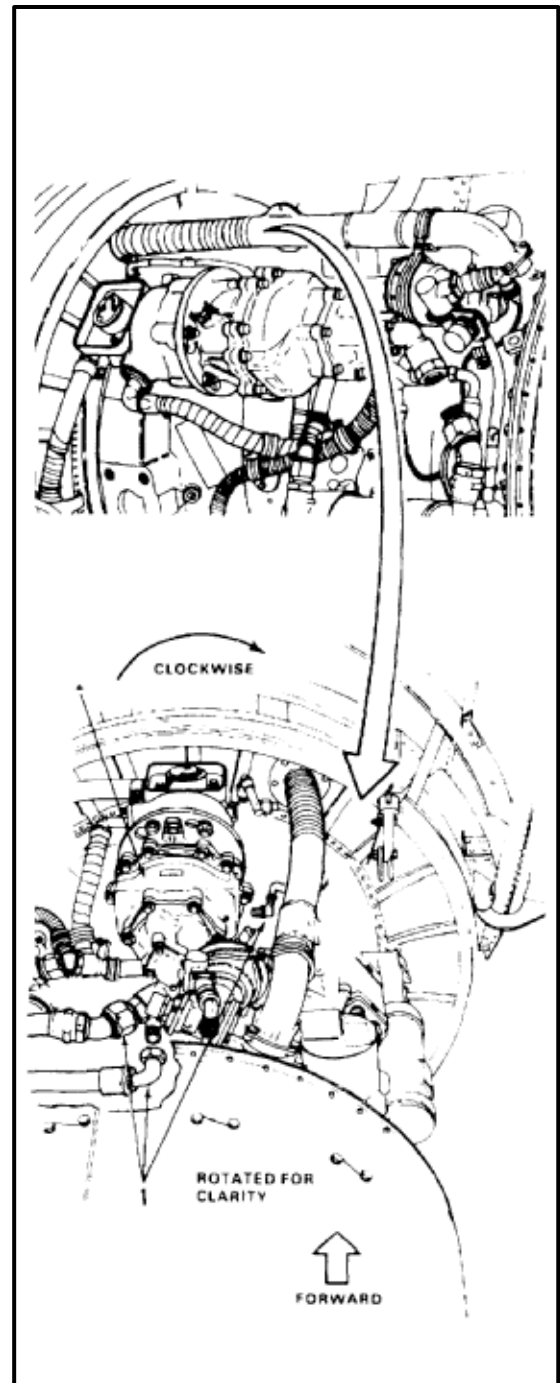

2. Loosen six nuts (3). Turn starter (2) clockwise to clear nuts. Remove starter and gasket (4).

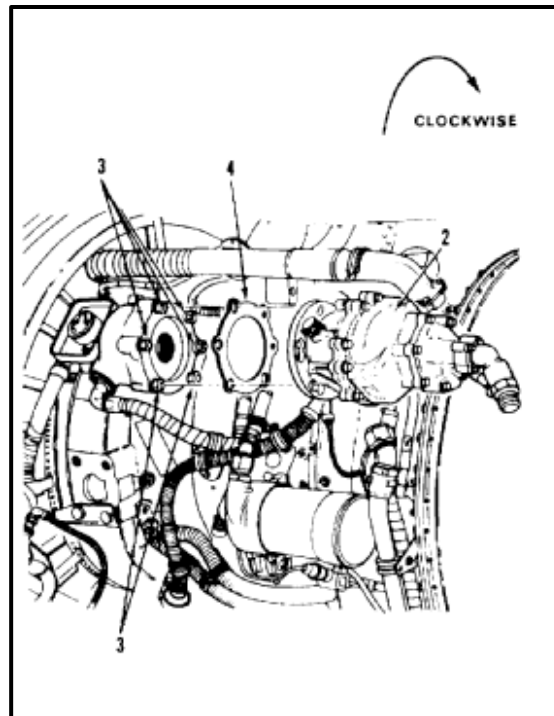
**FOLLOW-ON MAINTENANCE:**

None

END OF TASK

7-638

INITIAL SETUP

Applicable Configurations:

All

Tools:

Aircraft Mechanic's Tool Kit, NSN 51 80-00-323-4692

Materials:

Plastilube (E280)

Parts:

Gasket

Personnel Required:Medium Helicopter Repairer
Inspector**References:**

TM 55-1520-240-23P

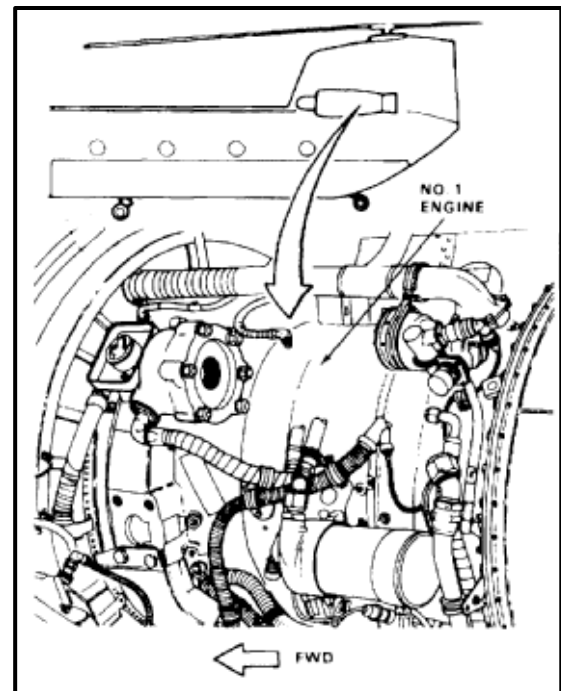
**NOTE**

Procedure is same to install No. 1 or No. 2 starter. Installation of No. 1 engine starter is shown here.

1. Coat splines (1) with plastilube (E280).
2. Install gasket (2) on mount (3).
3. Install starter (4) over six nuts. Turn starter counterclockwise until it cannot be turned further. Tighten nuts.

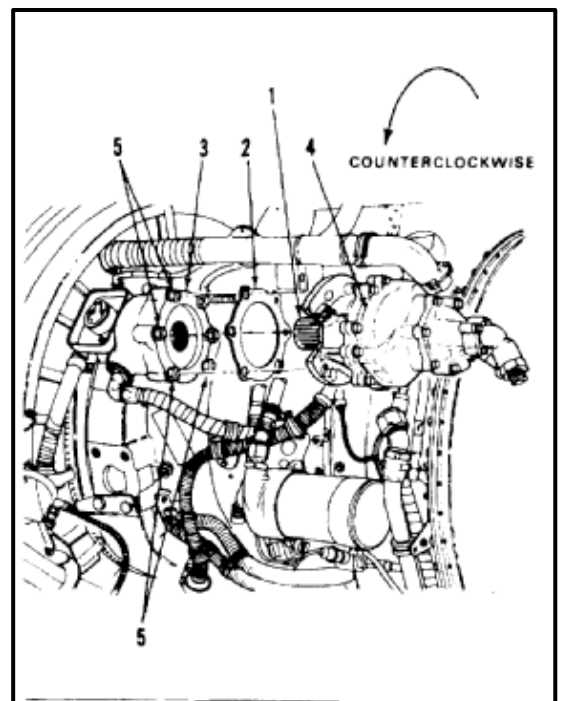

4. Connect tubes (6, 7, and 8) to starter (4).
Remove tags.

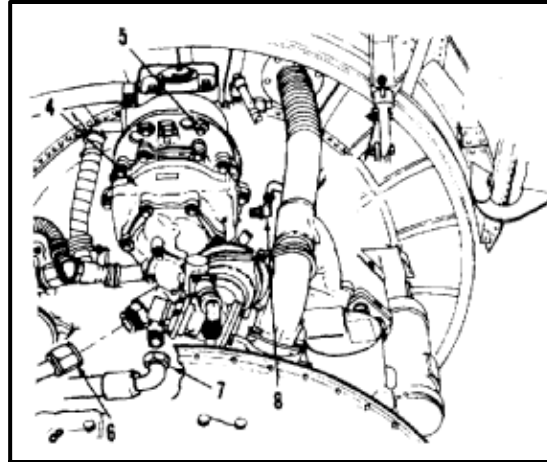
INSPECT**FOLLOW-ON MAINTENANCE:**

- Close engine access cover (Task 4-50).
- Perform operational check (TM 55-1520-240-T).

END OF TASK

7-640

7-143 REMOVE APU MOTOR PUMP

7-143

INITIAL SETUP**Applicable Configurations:**

All

Tools:

Aircraft Mechanic's Tool Kit, NSN 51 80-00-323-4692
 Open-End Wrench, 1 Inch
 Open-End Wrench, 1-1/2 Inch
 Container, 2 Quart

Materials:

Cloths (E135)
 Barrier Material (E81)
 Paper Tags (E264)
 Tape (E388)
 Gloves (E186)

Personnel Required:

Medium Helicopter Repairer (2)

Equipment Condition:

Battery Disconnected (Task 1-39)
 Electrical Power Off
 Hydraulic Power Off
 Utility Hydraulic System Depressurized (Task 7-135.1)
 Aft Transmission Access Panels Open (Task 2-2)
 Aft Transmission Drip Pan Removed (Task 2-3)
 APU Drip Pan Removed (Task 2-3)
 Cargo Ramp Open and Level (TM 55-1520-240-T)

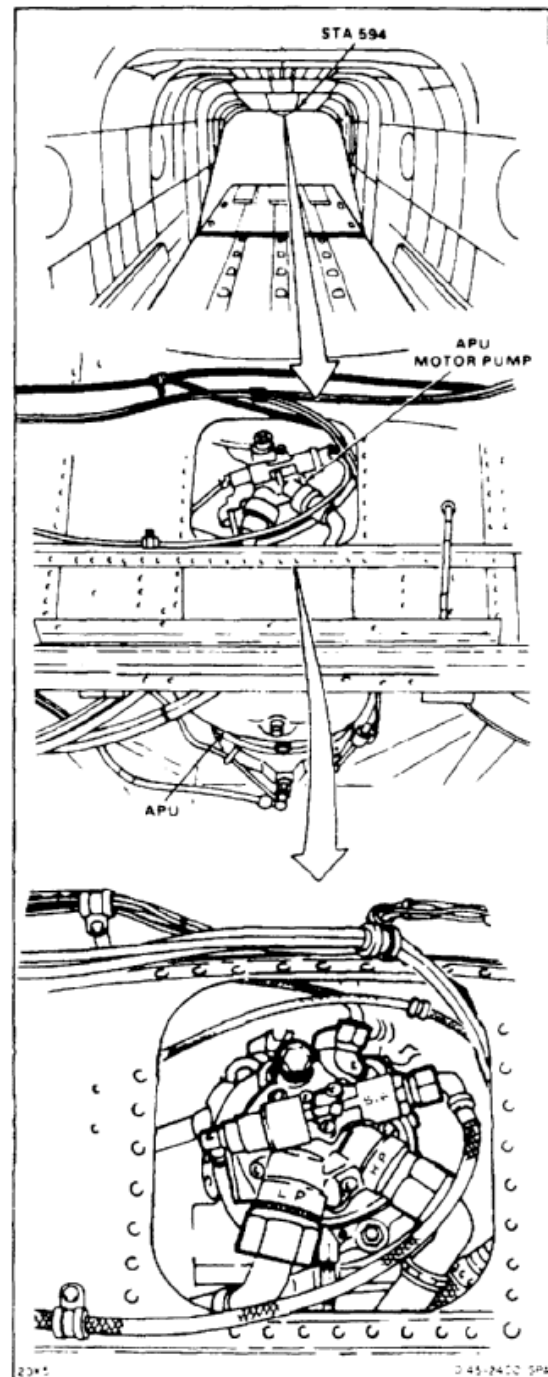

1. Disconnect five hydraulic hoses (1) from pump (2). Use container and cloths (E135) for spilled fluid. Use gloves (E186).

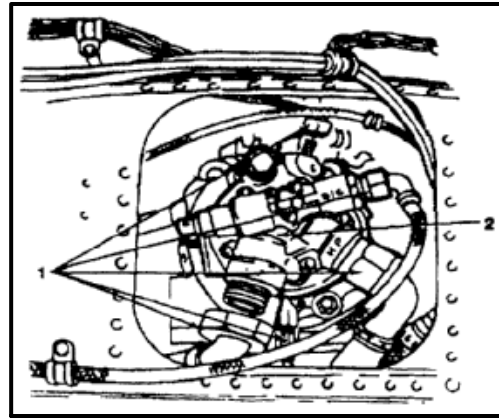

CAUTION

Do not support weight of motor pump on shaft during removal. Weight of pump on shaft can cause damage to shaft. This will result in leakage of hydraulic fluid.

2. Have helper support motor pump (2). Remove six nuts (3) and washers (4). Remove motor pump.

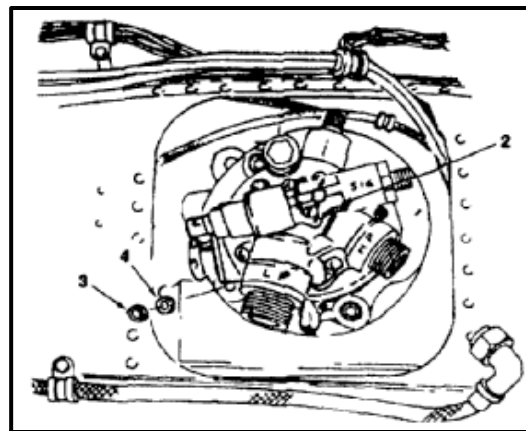

3. Wrap spline (5) with barrier material (E81) and tape (E388).
4. Remove gasket (6).

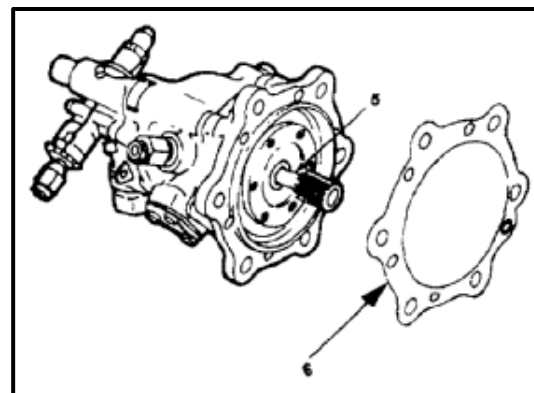

FOLLOW-ON MAINTENANCE:

None

END OF TASK

**7-144 REMOVE AND INSPECT APU MOTOR PUMP COUPLING AND SEAL (68WK02005-4)
(AVIM)**

7-144

INITIAL SETUP**Applicable Configurations:**

All

Tools:

Hydraulic Repairer's Tool Kit, NSN 5180-00-323-4891
 Technical Inspection Tool Kit, NSN 5180-00-323-5114

Materials:

None

Personnel Required:

Aircraft Pneudraulics Repairer
 Inspector

Equipment Condition:

Off Helicopter Task

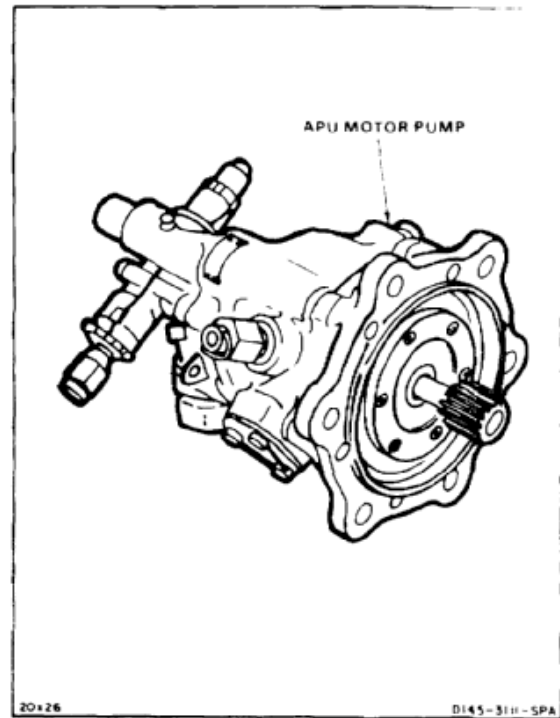
**NOTE**

General inspection criteria (Task 7-1.1) for obvious damage applies unless otherwise stated.

Inspection steps cover parts that are subject to wear.

1. Remove retainer (1) from plate (2) of motor pump (3). Use thin bladed screwdriver (4) under flanges (5). Push in and pry out.

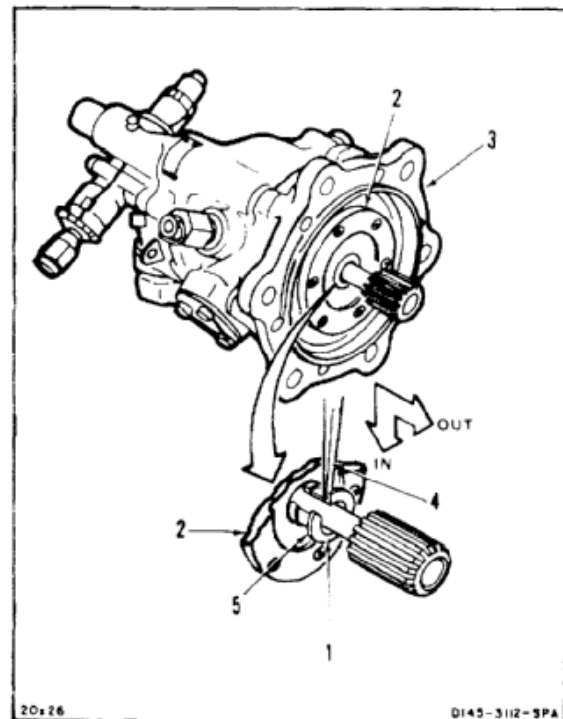

**7-144 REMOVE AND INSPECT APU MOTOR PUMP COUPLING AND SEAL (68WK02005-4)
(AVIM) (Continued)**

2. Slide coupling (6) out of motor pump shaft (7).
- 2.1. Inspect coupling (6). Coupling shall have no cracked or chipped splines.
3. Remove retainer (1) from coupling (6).
4. Remove six screws (8) from plate (2). Remove plate.

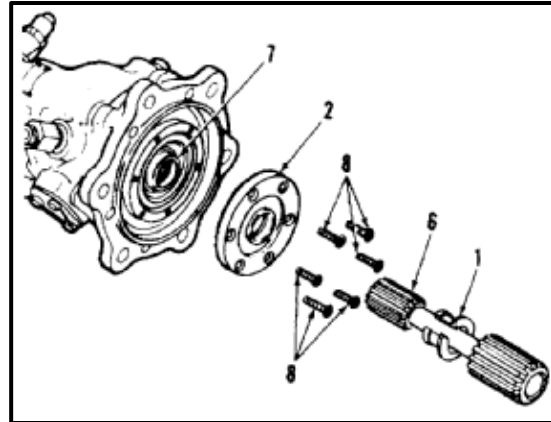

5. Remove ring (9) from plate (2).
6. Remove packing (10) from ring (9).

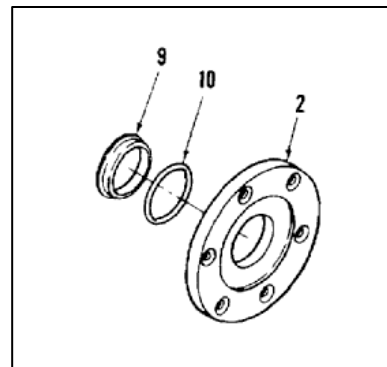

7. Remove packing (11) from motor pump (3).
8. Remove ring (12) from shaft (7).
9. Remove washer (13), packing (14), and retainer (15) from ring (12).
10. Remove spring (16) and ring (17) from shaft (7).
11. Inspect spring (16). Spring shall not be cracked or crushed flat.

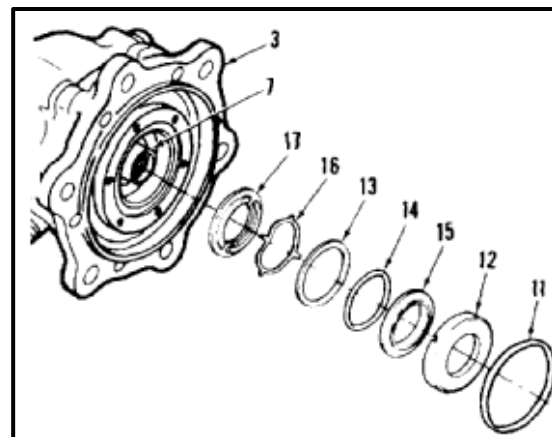

FOLLOW-ON MAINTENANCE:

None

END OF TASK

INITIAL SETUP

Applicable Configurations:

All

Tools:

Hydraulic Repairer's Tool Kit, NSN 5180-00-323-4891
Torque Wrench, 5 to 50 Inch-Pounds

Materials:

None

Parts:

Preformed Packings
Retainer
Washer

Personnel Required:

Aircraft Pneudraulics Repairer
Inspector

References:

TM 55-1520-240-23P

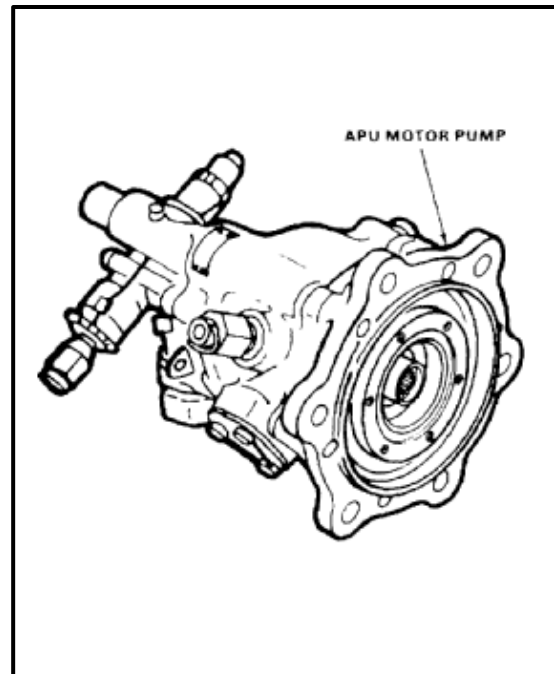

1. Install ring (1) on shaft (2) of motor pump (3) with slots (4) outward. Align pin (5) of motor pump (3) with hole (6) of ring.

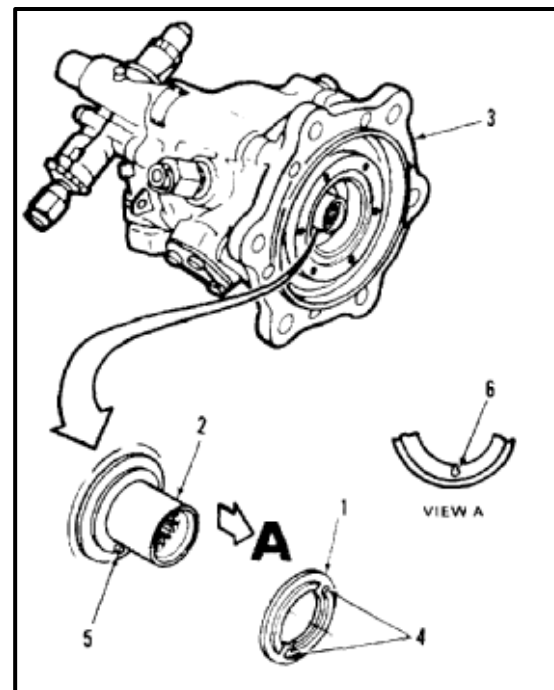

2. Install spring (7) on shaft (2). Make sure tangs (8) of spring engage slots in ring (1).
3. Install retainer (9), packing (10), and washer (11) in ring (12).
4. Install ring (12) on shaft (2) with slots (13) toward spring (7). Make sure tangs (8) of spring engage slots (13) of ring (12).
5. Install packing (14) in pump (3).

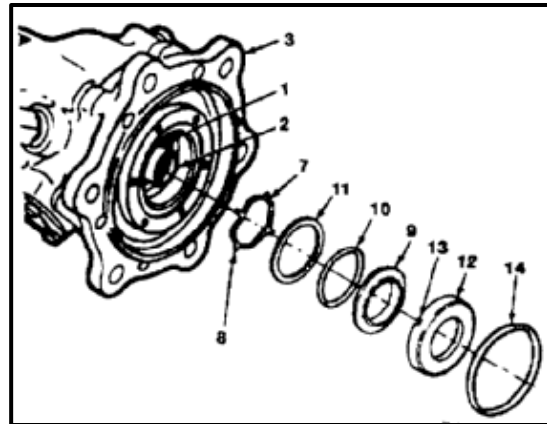

6. Install packing (15) on ring (16).
7. Install ring (16) in plate (17) from inboard side of plate.
8. Position plate (17) in pump (3). Install six screws (18). If self-locking screws turn freely, replace them. Torque screws to **20 inch-pounds**.

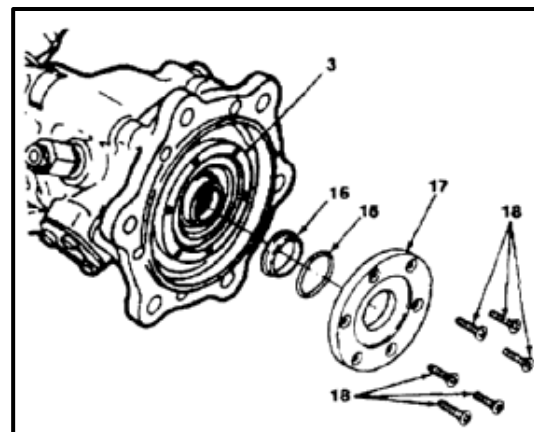

9. Install new retainer (19) on coupling (20).
10. Insert coupling (20) in shaft (2), small end inward.

INSPECT

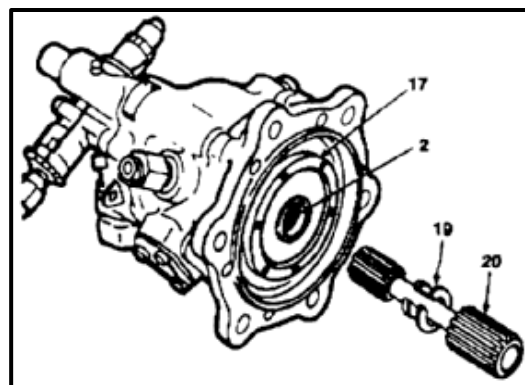

FOLLOW-ON MAINTENANCE:

Perform leak test (Task 7-146).

END OF TASK

INITIAL SETUP**Applicable Configurations:**

All

Tools:

Hydraulic Repairer's Tool Kit, NSN 5180-00-323-4891
 Hydraulic Test Stand
 Gage, 500 psi
 Shutoff Valve
 Restrictor Valve
 Hose, 1/4 Inch, 500 psi
 Stop Watch

Materials:

None

Parts:

Plugs

Personnel Required:

Aircraft Pneudraulic Repairer
 Inspector

Equipment Condition:

Off Helicopter Task
 APU Motor Pump Installed In Crash Proof Box
 Test Setup

General Safety Instructions:**WARNING**

Use suitable crash box to shield personnel and equipment in case of failure during test.

WARNING

Hydraulic fluid ejected under pressure can cause injury to personnel.
 Hydraulic fluid sprayed into the air is a fire hazard.

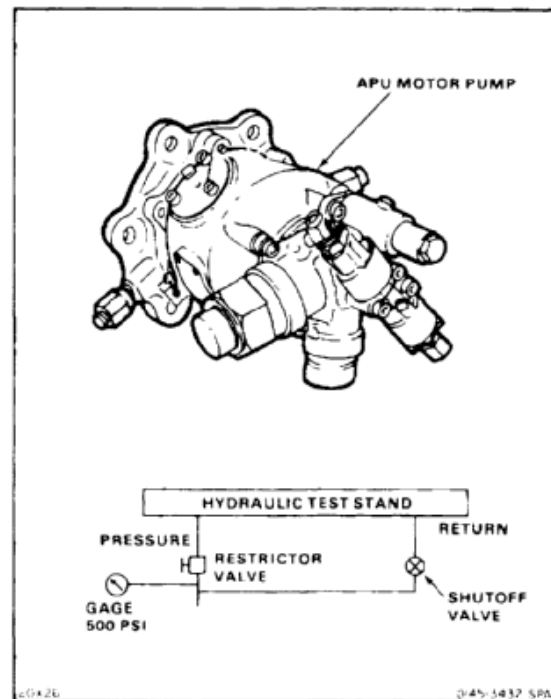

1. Install five pressure caps (1, 2, 3, 4, and 5) in seal drain port (6), main engine port (7), signal line port (8), high pressure port (9), and low pressure port (10) of motor pump (11).
2. Connect test stand pressure hose (12) to case drain port (13).
3. Close valve (14).
4. Apply **300 psi** pressure to port (13). Adjust valve (15) for **1300 psi** on gage (16). Maintain pressure for **5 minutes**.
5. Check for leaks at seal plate (17). There shall be no leaks.
6. Close valve (15). Open valve (14).
7. Disconnect pressure hose (12) from port (13).
8. Remove five caps (1, 2, 3, 4, and 5) from ports (6, 7, 8, 9, and 10).
9. Turn shaft (19) by hand. Shaft shall turn evenly without binding or noise.

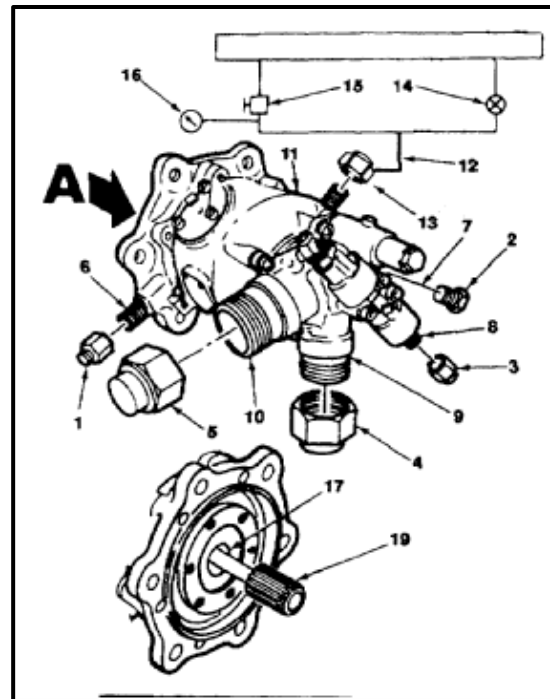
**INSPECT****FOLLOW-ON MAINTENANCE:**

None

END OF TASK

7-648

INITIAL SETUP

Applicable Configurations:

All

Tools:

Aircraft Mechanic's Tool Kit, NSN 51 80-00-323-4692
 Open-End Wrench, 1 Inch
 Open-End Wrench, 1-1/4 Inch
 Torque Wrench, 100 to 750 Inch-Pounds
 Container, 2 Quart

Materials:

Cloths (E135)
 Hydraulic Fluid (E199)
 Grease (E190)

Parts:

Gasket

Personnel Required:

Medium Helicopter Repairer (2)
 Inspector

References:

TM 55-1520-240-23P

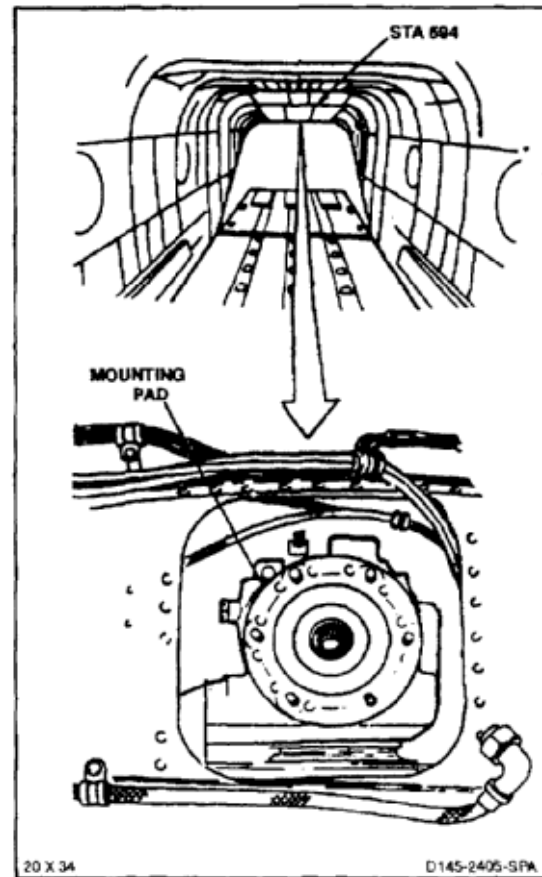

1. If motor pump (1) is being replaced, do the following:
 - a. Place container under motor pump (1). Remove three caps (2) and cap (3). Drain preservative fluid.
 - b. Install three caps (2).

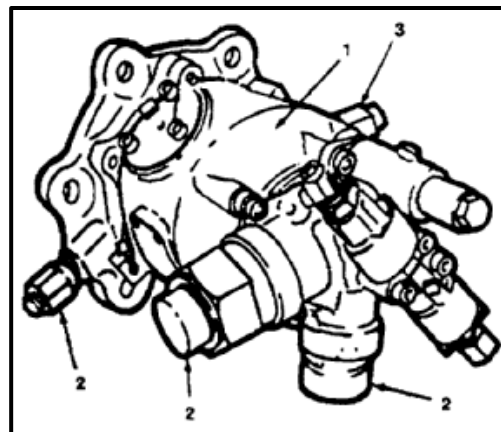

CAUTION

Do not install motor pump with dry case. This will cause internal damage to pump.

2. Fill case of motor pump (1) through case drain port (4) with clean hydraulic fluid (E199).
3. Install cap (3) on fitting (5). Use cloths (E135) for spilled fluid.
4. Remove barrier material and coat splines (6) with grease (E190).
- 4.1. Install gasket (7).

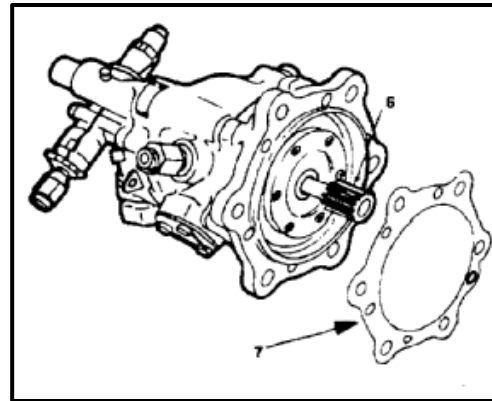
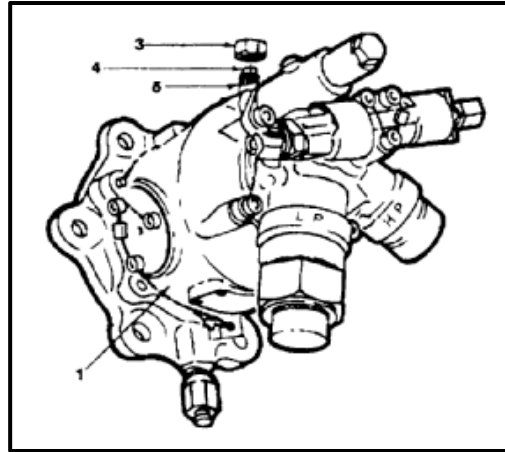

CAUTION

Do not support weight of motor pump on shaft during Installation. Weight of pump on shaft can cause damage to shaft. This will result in leakage of hydraulic fluid.

5. Position motor pump (1) on six studs (7) with LP port (4) down. Have helper support motor pump.
6. Install six washers (8) and nuts (9). Torque nuts (9) to **160 inch-pounds**.

7. Remove cap and connect tube (10) to HP port (11).
8. Remove cap and connect tube (12) to LP port (13). Remove tag.
9. Remove cap and connect hose (14) to SIG port (15). Remove tag.
10. Remove cap and connect hose (16) to case drain port (17). Remove tag.
11. Remove cap and connect hose (18) to seal drain port (4). Remove tag.

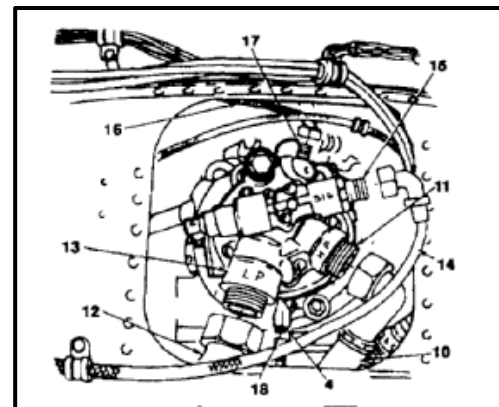
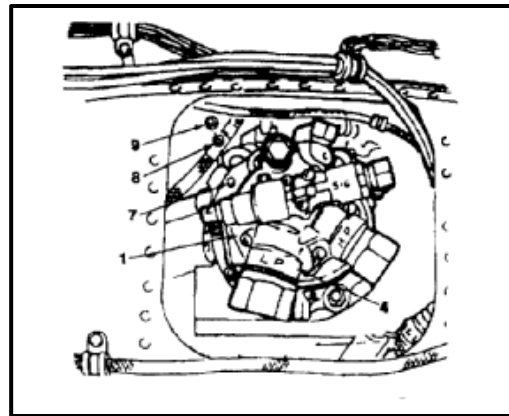

INSPECT

FOLLOW-ON MAINTENANCE:

- Bleed motor pump (Task 7-336).
- Perform operational check (TM 55-1520-240-T).
- Close aft transmission access panels (Task 2-2).
- Install aft transmission drip pan (Task 2-3).
- Install APU drip pan (Task 2-3).
- Close cargo ramp (TM 55-1520-240-T).

END OF TASK

INITIAL SETUP

Applicable Configurations:

All

Tools:

Aircraft Mechanic's Tool Kit, NSN 5180-00-323-4692

Materials:

None

Personnel Required:

Medium Helicopter Repairer

Equipment Condition:

- Battery Disconnected (Task 1-39)
- Electrical Power Off
- Hydraulic Power Off
- Utility Hydraulic System Depressurized (Task 7-135.1)
- APU Start Accumulator Air Charge Depressurized (Task 1-64)
- Right Aft Transmission Access Door Open (Task 2-2)
- Cargo Ramp Open and Level (TM 55-1520-240-T)

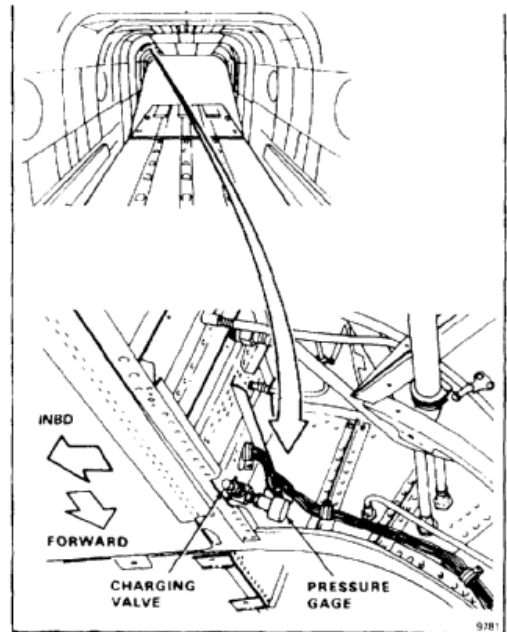

WARNING

High pressure air trapped under valve cap can be a hazard. If cap is not removed slowly, air can pop it off and cause injury.

1. Loosen cap (1) on charging valve (2) **one or two turns**. Allow any trapped air to escape. Remove cap.

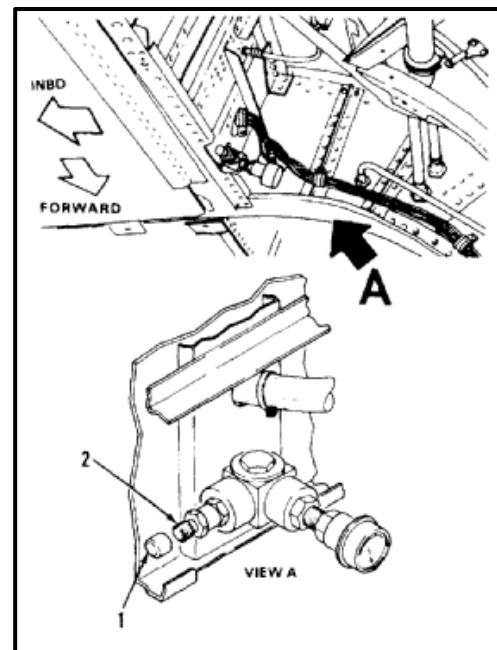

7-147.1 REMOVE AIR CHARGING VALVE AND PRESSURE GAGE FROM APU START ACCUMULATOR (Continued)

7-147.1

REMOVE AIR CHARGING VALVE

2. Remove lockwire from nut (3). Hold inner nut with wrench and turn outer nut (4) counterclockwise to loosen and depressurize accumulator (5).
3. Remove lockwire from inner nut (4). Hold four way fitting (6) with wrench and loosen nut (4).

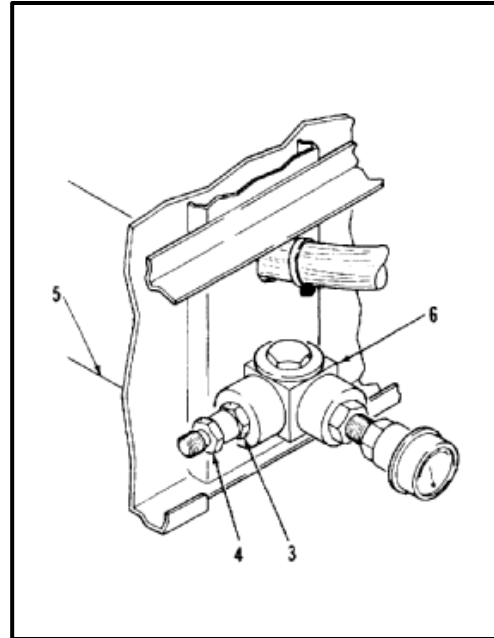

4. Remove air charging valve (2) and packing (7) from four way fitting (6).

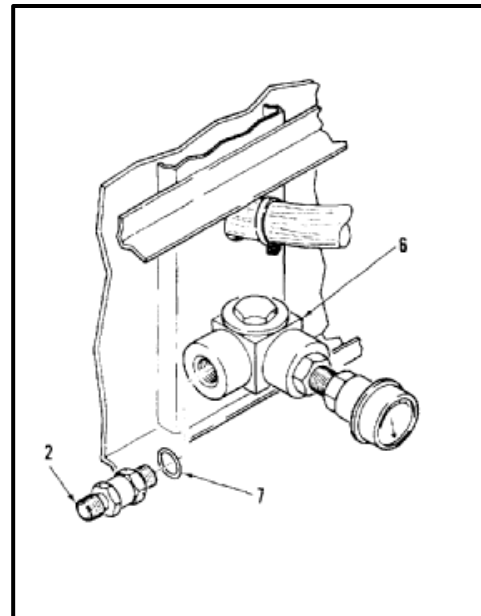

REMOVE PRESSURE GAGE

5. Hold gage (8) and loosen outer gage nut (9).

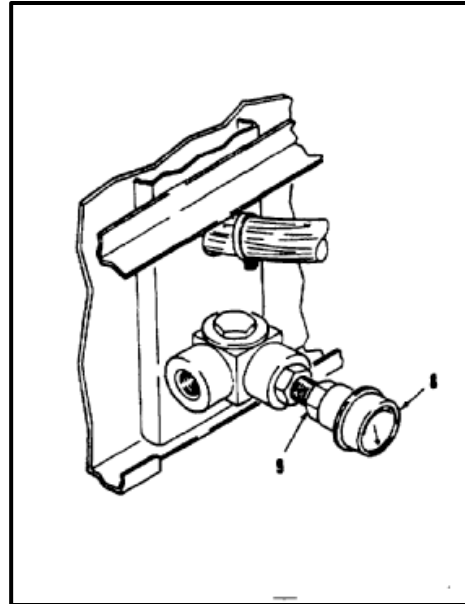

6. Remove gage (8), packing (10), retaining ring (11), and nut (9) from union (12) on four way fitting (6).

FOLLOW-ON MAINTENANCE:

None

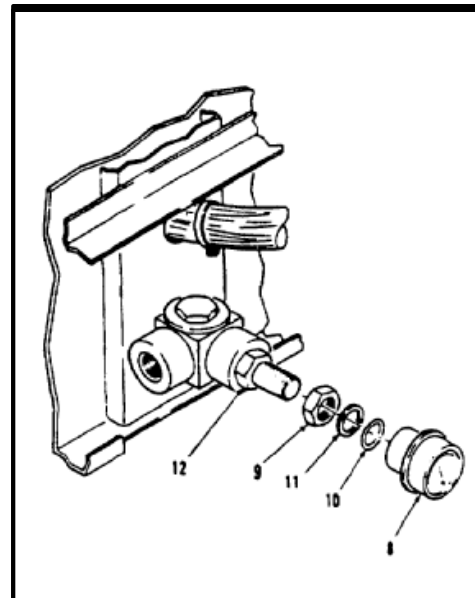

END OF TASK

7-147.2 INSTALL AIR CHARGING VALVE AND PRESSURE GAGE ON APU START ACCUMULATOR 7-147.2**INITIAL SETUP****Applicable Configurations:**

All

Tools:

Aircraft Mechanic's Tool Kit, NSN 5180-00-323-4692
Torque Wrench, 100 to 750 Inch-Pounds

Materials:

Lockwire (E231)
Petrolatum (E274)

Parts:

Preformed Packings
Retainers

Personnel Required:

Medium Helicopter Repairer
Inspector

References:

TM 55-1520-240-23P

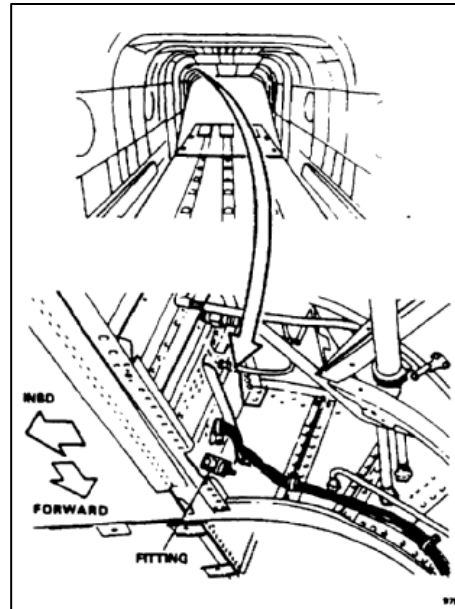
**WARNING**

When tightening nut, do not turn it past the non-threaded portion of the fitting. Packing will rise onto threads and eventually leak.

WARNING

Prior to installation, check pressure gauge vent hole for freedom of obstructions. There shall not be anything covering vent hole.

NOTE

Apply a light coating of petrolatum (E274) or fluid (E199) to threads, packings, and retaining rings during assembly.

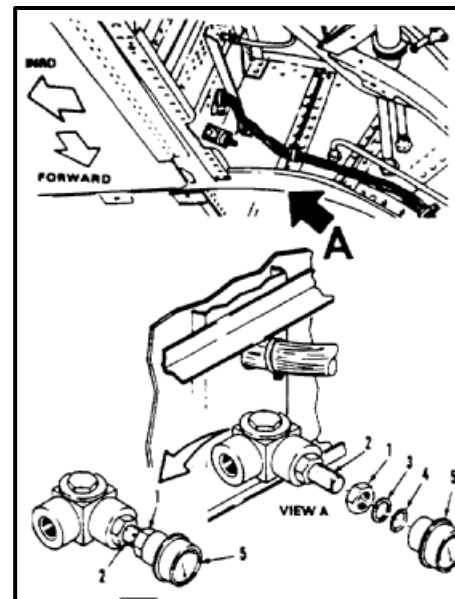
**INSTALL PRESSURE GAGE**

1. Install nut (1) on union (2). Position retainer (3) and packing (4) on union.
2. Install gage (5) on union (2).
3. Torque nut (1) to **135 inch-pounds**.

INSTALL AIR CHARGING VALVE

4. Position packing (6) on air charging valve (7).
5. Install valve (7) on four way fitting (8).
6. Hold fitting (8) with wrench. Torque nut (9) to **125 to 145 inch-pounds**.
7. Hold nut (9) with wrench. Torque nut (10) to **125 to 145 inch-pounds**.
8. Lockwire nut (9) to fitting (8).
9. Install cap (11) on air charging valve (7).

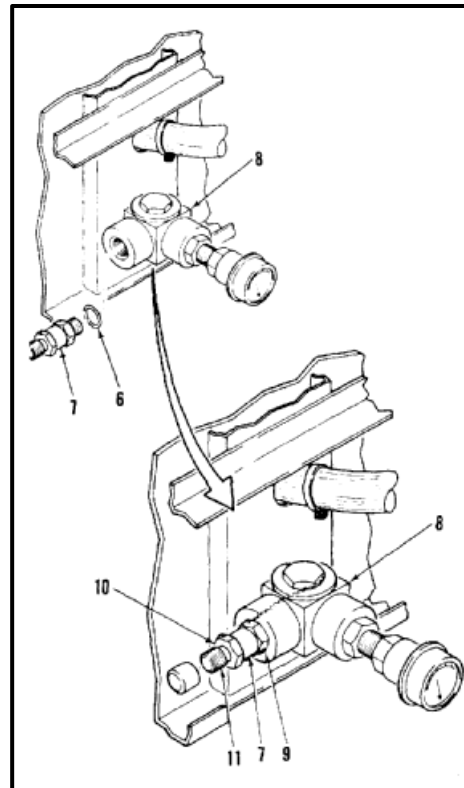
INSPECT**FOLLOW-ON MAINTENANCE:**

Service utility system APU start accumulator (Task 1-64).

END OF TASK

7-656

7-148 REMOVE APU START ACCUMULATOR

7-148

INITIAL SETUP**Applicable Configurations:**

All

Tools:

Aircraft Mechanic's Tool Kit, NSN 51 80-00-323-4692
Container, 2 Quart

Materials:

Cloths (E135)
Gloves (E186)

Personnel Required:

Medium Helicopter Repairer

References:

TM 1-1520-253-23

Equipment Condition:

Battery Disconnected (Task 1-39)
Electrical Power Off
Hydraulic Power Off
Utility Hydraulic System Depressurized (Task 7-135.1)
APU Start Accumulator Air Charge Depressurized
(Task 1-64)
Right Aft Transmission Access Door Open (Task 2-2)
Cargo Ramp Open and Level (TM 55-1520-240-T)

General Safety Instructions:**WARNING**

Hydraulic fluid (E199) is toxic. It can irritate skin and cause burns. Avoid inhaling. Use only with adequate ventilation. Avoid contact with skin, eyes, or clothing. In case of contact, immediately flush skin or eyes with water for at least **15 minutes**. Get medical attention for eyes.

WARNING

Hydraulic fluid ejected under pressure can cause injury to personnel. Hydraulic fluid sprayed into the air is a fire hazard.

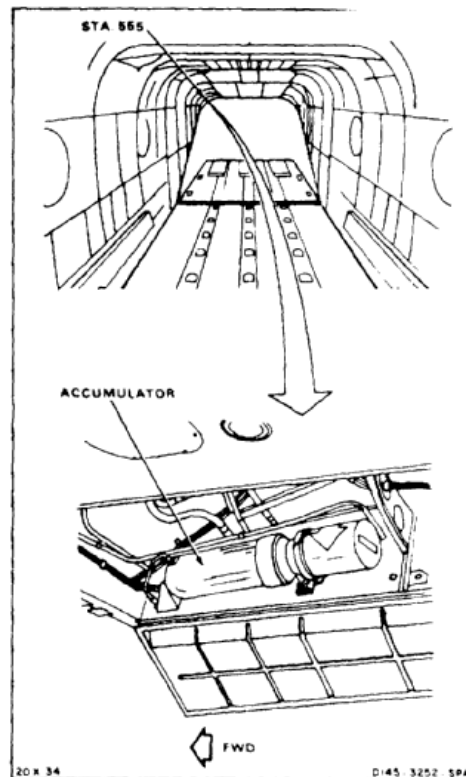

WARNING

Make sure accumulator precharge is depleted.

NOTE

If a crack in the accumulator is suspected, refer to TM 1-1520-253-23.

1. Deleted.
2. Remove line (2) between accumulator (1) and fitting (3). Use container and cloths (E135) for spilled fluid. Use gloves (E186).
3. Remove two bolts (4) and washers (5) from mount (6).
4. Remove accumulator (1). Turn the accumulator as necessary to clear obstacles. Use container and cloths (E135) for spilled fluid.
5. Remove four retainers (7) and two packings (8) from plate (9).

FOLLOW-ON MAINTENANCE:

None

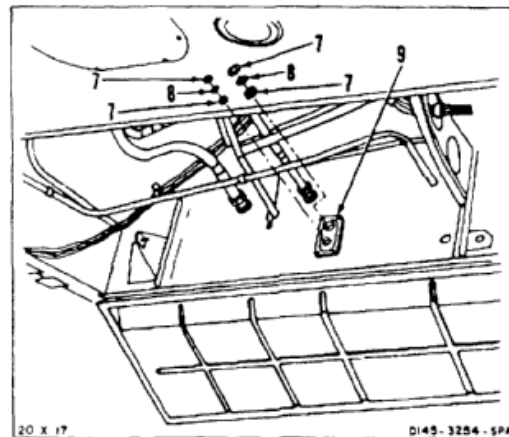
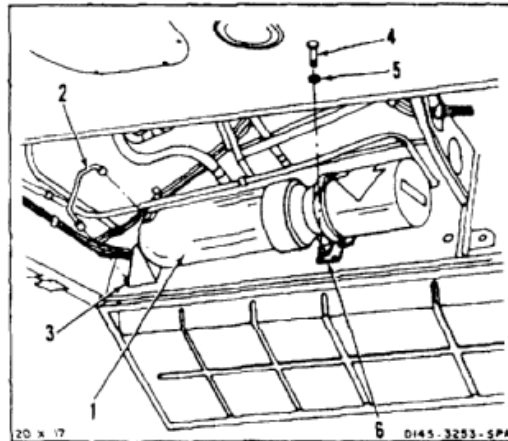

END OF TASK

7-658

7-148.1 REPLACE APU START ACCUMULATOR TRANSFER TUBES

7-148.1

INITIAL SETUP**Applicable Configurations:**

All

Tools:

Hydraulic Repairer's Tool Kit, NSN 5180-00-323-4891

Materials:

Cloth (E120)
 Solvent (E161)
 Hydraulic Fluid (E199)
 Gloves (E186)

Parts:

Preformed Packings
 Retainers

Personnel Required:

Aircraft Pneudraulics Repairer
 Inspector

References:

TM 55-1520-240-23P

Equipment Condition:

APU Start Accumulator Removed (Task 7-148)

General Safety Instructions:**WARNING**

Solvent (E161) is combustible and toxic. It can irritate skin and cause burns. Use only with adequate ventilation, away from open flame. In case of contact, immediately flush skin or eyes with water for at least **15 minutes**. Get medical attention for eyes.

WARNING

Hydraulic fluid (E199) is toxic. It can irritate skin and cause burns. Avoid inhaling. Use only with adequate ventilation. Avoid contact with skin, eyes, or clothing. In case of contact, immediately flush skin or eyes with water for at least **15 minutes**. Get medical attention for eyes.

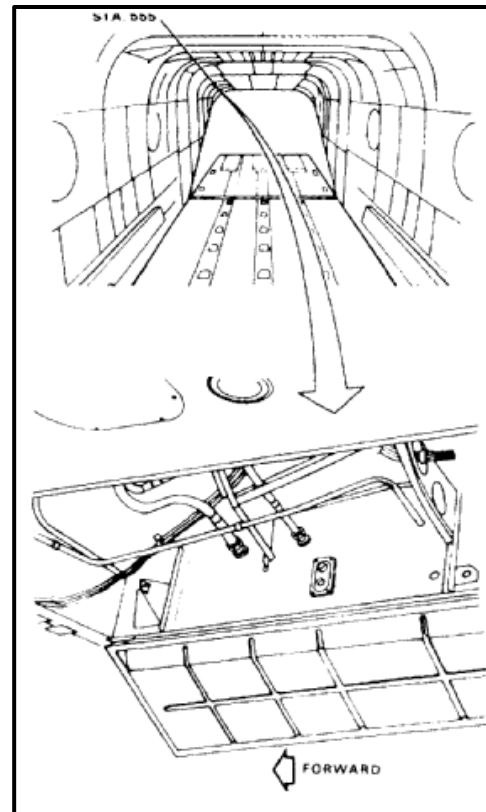

REMOVE TUBES

1. Remove retaining ring (1), retaining washer (2), and transfer tube (3) from APU start accumulator mounting plate (4).
2. Remove retaining ring (5), retaining washer (6), and transfer tube (7) from mounting plate (4).

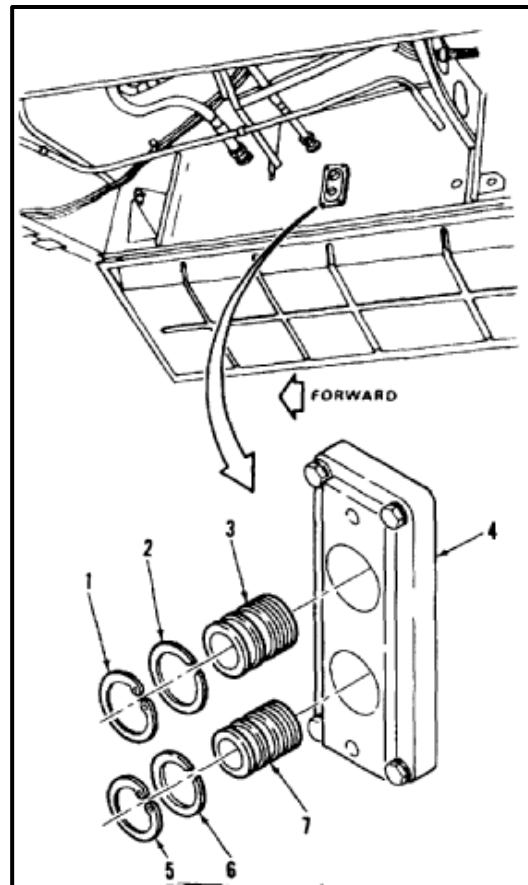

3. Remove four retainers (8) and two packings (9) from transfer tube (3).
4. Remove four retainers (10) and two packings (11) from transfer tube (7).

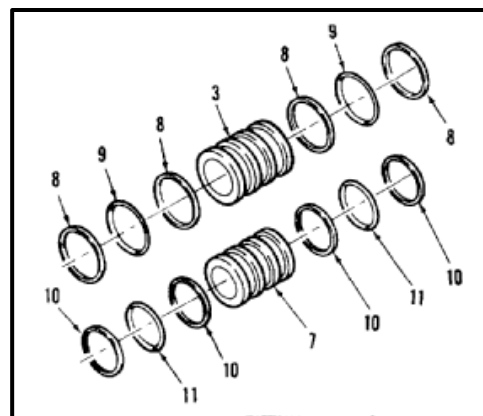

7-148.1 REPLACE APU START ACCUMULATOR TRANSFER TUBES (Continued)

7-148.1

INSTALL TUBES

5. Coat packings (9 and 11) and retainers (8 and 10) with hydraulic fluid (E199).
6. Install two packings (9) and four retainers (8) on transfer tube (3).
7. Install two packings (11) and four retainers (10) on transfer tube (7).

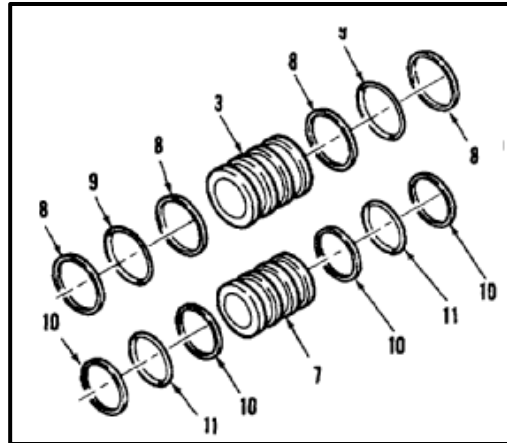

8. Clean pressure port and return port in mounting plate (4). Use a clean cloth (E120) wet with solvent (E161). Wear gloves (E186).
9. Coat inside of pressure port and return port with hydraulic fluid (E199).
10. Install transfer tube (3), retaining washer (2), and retaining ring (1) in mounting plate (4).
11. Install transfer tube (7), retaining washer (6), and retaining ring (5) in mounting plate (4).

INSPECT**FOLLOW-ON MAINTENANCE:**

Install APU start accumulator (Task 7-149).

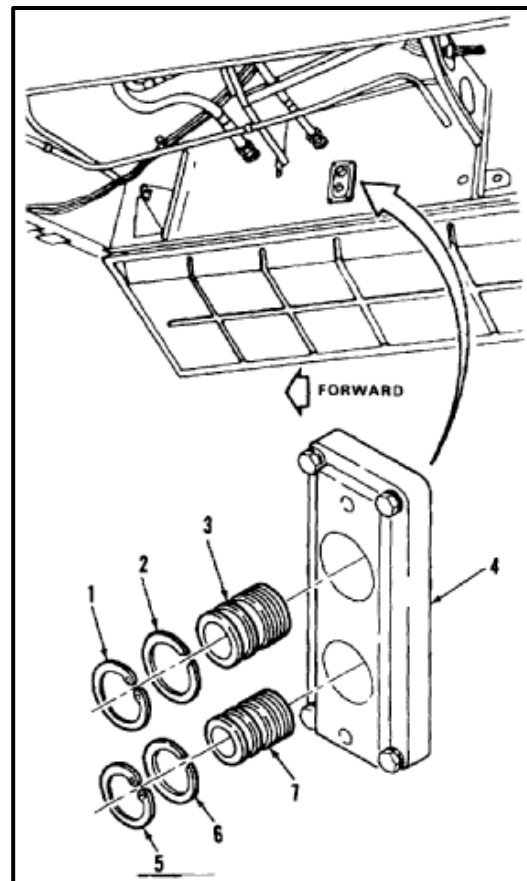

END OF TASK

INITIAL SETUP

Applicable Configurations:

All

Tools:

Hydraulic Repairer's Tool Kit, NSN 5180-00-323-4891
Container, 2 Quart

Materials:

Cloths (E120)
Gloves (E186)

Personnel Required:

Aircraft Pneudraulics Repairer
Inspector

Equipment Condition:

APU Start Accumulator Removed (Task 7-148)

General Safety Instructions:**WARNING**

Hydraulic fluid (E199) is toxic. It can irritate skin and cause burns. Avoid inhaling. Use only with adequate ventilation. Avoid contact with skin, eyes, or clothing. In case of contact, immediately flush skin or eyes with water for at least **15 minutes**. Get medical attention for eyes.

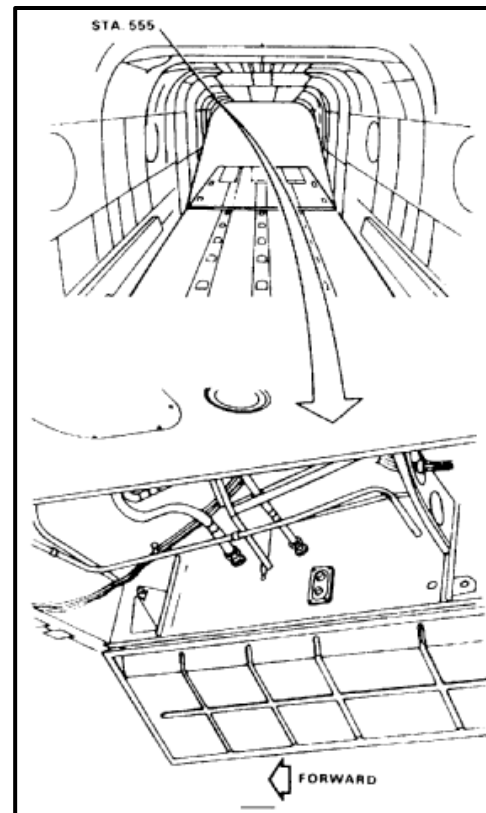
**REMOVE PLATE**

1. Disconnect tube (1) from mounting plate (2). Use container and cloths (E120) for spilled fluid. Wear gloves (E186).
2. Loosen nut (3) and disconnect tee (4) from mounting plate (2). Use container and cloths (E120) for spilled fluid. Wear gloves (E186).

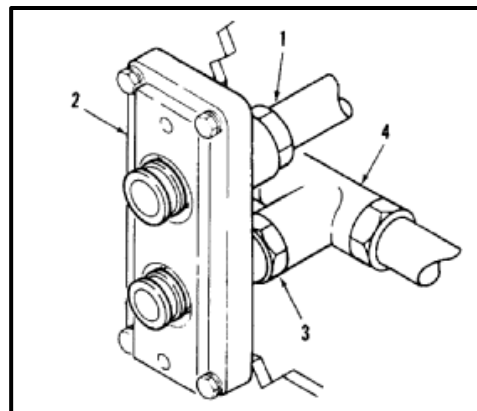

7-148.2 REPLACE APU START ACCUMULATOR MOUNTING PLATE (Continued)

7-148.2

- Remove four bolts (5), four washers (6), and mounting plate (2) from structure.

INSTALL PLATE

- Clean structure in the area of mounting plate (2). Use cloths (E120).
- Install mounting plate (2), four washers (6), and four bolts (5).

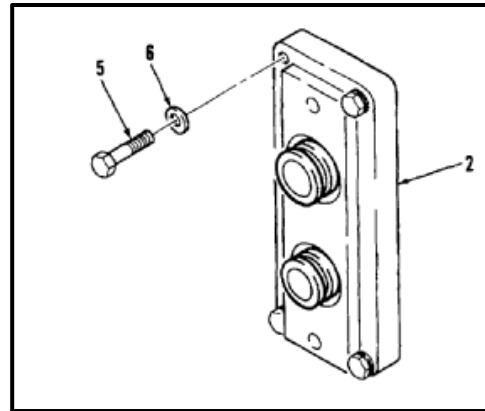

- Connect tee (4) to mounting plate (2). Tighten nut (3).
- Connect tube (1) to mounting plate (2).

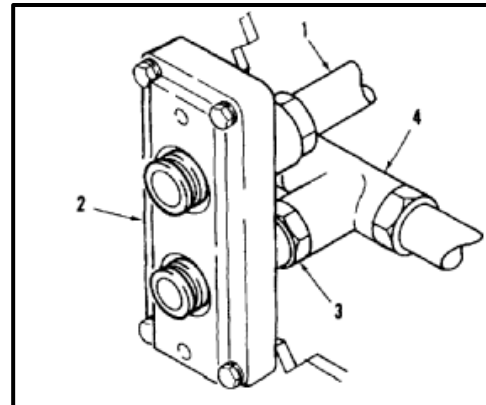
INSPECT**FOLLOW-ON MAINTENANCE:**

Install APU start accumulator (Task 7-149).

END OF TASK

INITIAL SETUP

Applicable Configurations:

All

Tools:

Aircraft Mechanic's Tool Kit, NSN 5180-00-323-4692
Torque Wrench 100 to 750 Inch-Pounds

Materials:

Hydraulic Fluid (E199)

Parts:

Preformed Packings
Retainers

Personnel Required:

Medium Helicopter Repairer
Inspector

References:

TM 55-1520-240-23P

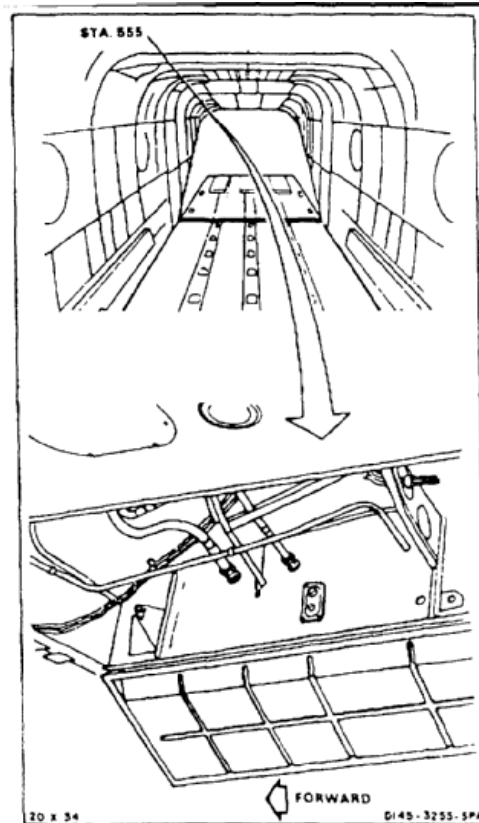

1. Install four retainers (1) and two packings (2) on mount (3). Lubricate packings with hydraulic fluid (E199).

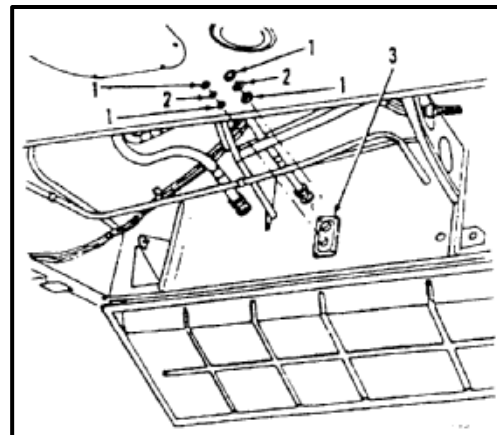

2. Position accumulator (4) on pin at base of mount (5). Pivot accumulator into position being careful to engage transfer tubes into accumulator without damaging seals. Install two bolts (6) and washers (7).
3. Check that there is a gap of **0.06 to 0.25 inch** between mount and accumulator.
4. Torque bolts to **250 inch-pounds**.
5. Install line (8) between accumulator (4) and fitting (9).

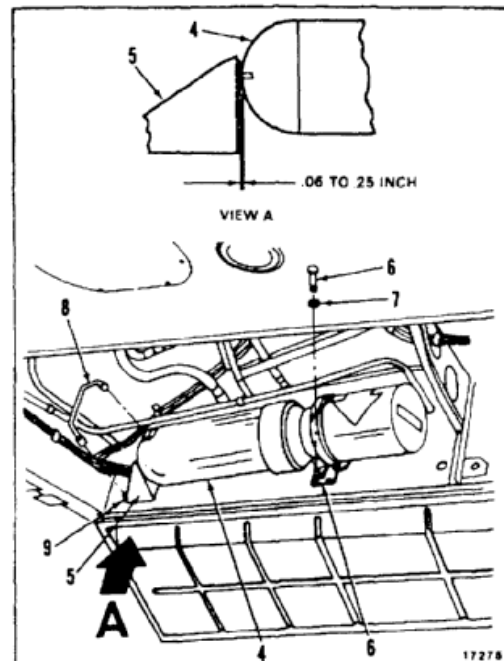
INSPECT**FOLLOW-ON MAINTENANCE:**

- Service accumulator air charge (Task 1-65).
- Bleed utility hydraulic reservoir/cooler, APU pump/motor and utility pump system (Task 7-336).
- Perform operational check (TM 55-1520-240-T).
- Close right aft transmission access door (Task 2-2).
- Close cargo ramp (TM 55-1520-240-T).

END OF TASK

INITIAL SETUP

Applicable Configurations:

All

Tools:

Aircraft Mechanic's Tool Kit, NSN 5180-00-323-4692
 Open-End Wrench, 1-1/4 Inch
 Open-End Wrench, 1-1/2 Inch
 Container, 2 Quart

Materials:

Barrier Material (E81)
 Cloths (E135)
 Paper Tags (E264)
 Tape (E388)
 Gloves (E184.1)

Personnel Required:

Medium Helicopter Repairer

Reference:

TM 1-1520-253-23

Equipment Condition:

Battery Disconnected (Task 1-39)
 Electrical Power Off
 Hydraulic Power Off
 Utility Hydraulic System Depressurized (Task 7-135.1)
 Right Aft Transmission Access Panel Open (Task 2-2)
 Cargo Ramp Open and Level (TM 55-1520-240-T)

General Safety Instructions:**WARNING**

Hydraulic fluid (E199) is toxic. It can irritate skin and cause burns. Avoid inhaling. Use only with adequate ventilation. Avoid contact with skin, eyes, or clothing. In case of contact, immediately flush skin or eyes with water for at least **15 minutes**. Get medical attention for eyes.

WARNING

Hydraulic fluid ejected under pressure can cause injury to personnel.
 Hydraulic fluid sprayed into the air is a fire hazard.

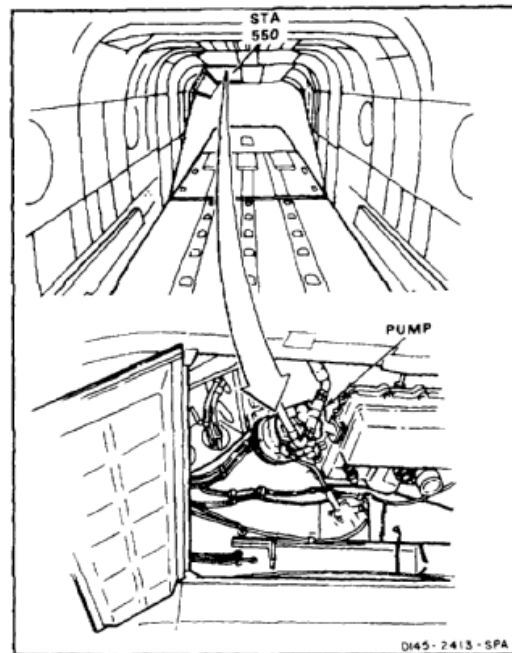

NOTE

If a crack in the hydraulic pump casing is suspected during removal, refer to TM 1-1520-253-23.

1. Tag and disconnect four hoses (1) from pump (2). Use tag (E264).

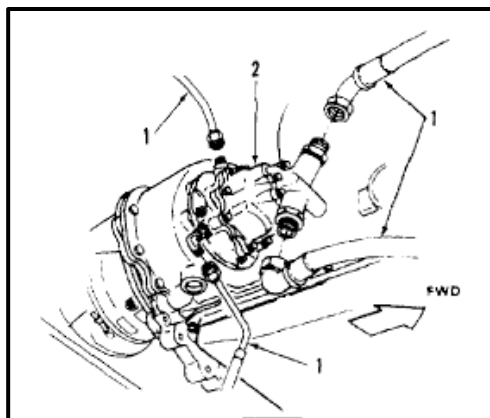

2. Remove four nuts (3).
3. Remove pump (2) and gasket (2.1).
4. Cover pump (2) mount with barrier material (E81) or equivalent.

NOTE

When removing a Stratopower/ Dynapower pump there is a metal shim bonded to pump flange. If this shim comes unbounded from the pump flange. It does not have to be rebounded for installation.

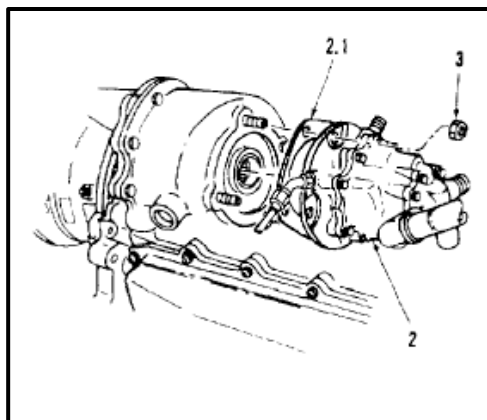

5. Wrap splines (4) with barrier material (E81) and tape (E388).

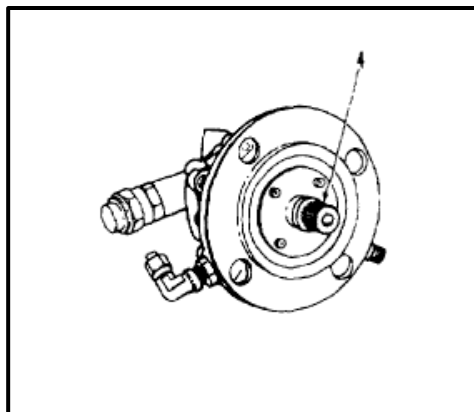

6. Tag and note position of elbow (5).
7. Remove elbow (5) and seal (6) from pump (2).
8. Remove check valve (7) and packing (8).
9. Remove union (9) and packing (10).
10. Remove union (11) and packing (12) in case drain port (13).
11. Visually inspect check valve (7) for damage to insure integration of inner moving parts. Valve should appear closed when viewed through small end (end toward base of directional arrow). The sealing plunger should make solid contact around circumference, and should appear flat. If seal does not appear to be total, or a gap is present, check valve should be replaced.

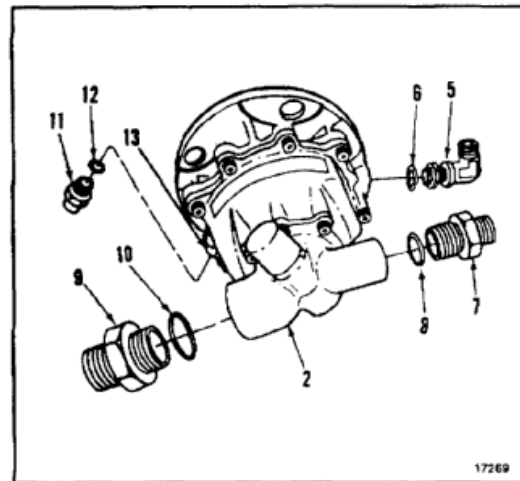
**FOLLOW-ON MAINTENANCE:**

None

END OF TASK

7-668

INITIAL SETUP

Applicable Configurations:

All

Tools:

Aircraft Mechanic's Tool Kit, NSN 51 80-00-323-4692
Open-End Wrench, 1-1/4 Inch
Open-End Wrench, 1-1/2 Inch

Materials:

Oil (E254 or E254.1)
Cloths (E135)
Hydraulic Fluid (E199)
Grease (E190)
Gloves (E184.1)

Parts:

Preformed Packings
Seal
Retainers

Personnel Required:

Medium Helicopter Repairer
Inspector

References:

TM 55-1520-240-23P

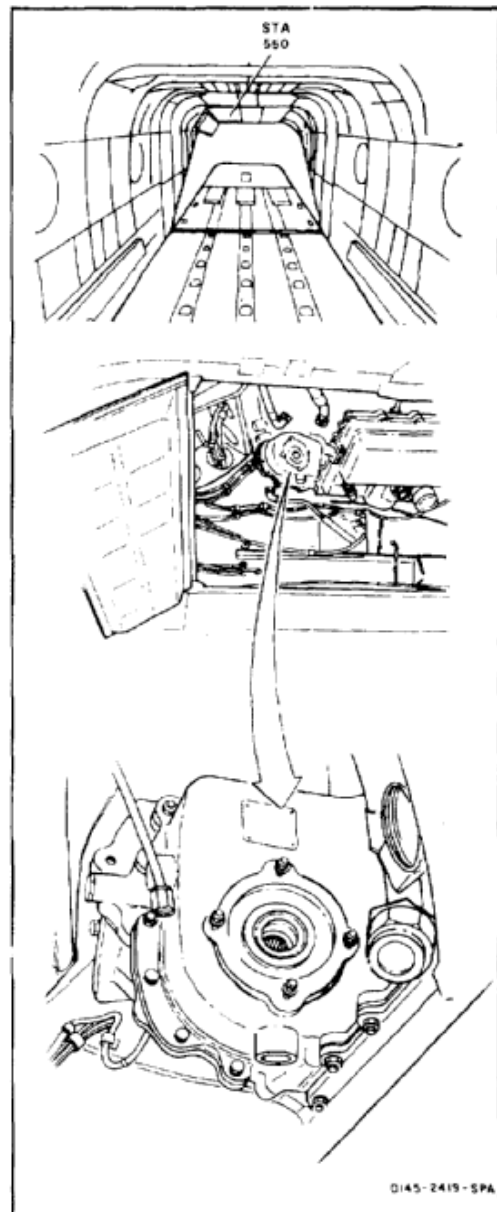

NOTE

Hydraulic Pump P/N 938555 (145HS100-3) is no longer the correct configuration after completion of ECP D213 and turnaround program (TB 1-1520-240-20-75). The correct P/N is 145HS100-4.

1. Install elbow (1), packing (2), and nut (3) in port (4). Remove tag.
2. Install union (5) and packing (6) in OUT port (7).
3. Install reducer (8) and packing (9) in IN port (10).
- 3.1. Install union (11) and packing (12) in port (13).
4. Cap elbow (1) union (5), reducer (8) and union (11) and ports (7, 10, and 13).

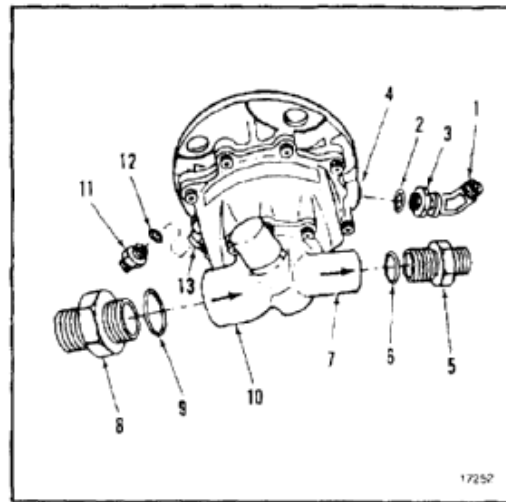
**WARNING**

Hydraulic fluid (E199) is toxic. It can irritate skin and cause burns. Avoid inhaling. Use only with adequate ventilation. Avoid contact with skin, eyes or clothing. In case of contact, immediately flush skin or eyes with water for at least **15 minutes**. Get medical attention for eyes.

CAUTION

Do not install pump with dry case. This can cause internal damage to pump.

5. Fill pump case (14) with clean hydraulic fluid (E199) through case drain port (15). Cap port. Wear gloves (E184.1).
6. Remove protective material from spline (16).
7. Coat entire surface of packing (15.1) and splines (15) with grease (E190). Install packing on spline. Wear gloves (E184.1).
8. Remove protective cover from mount.

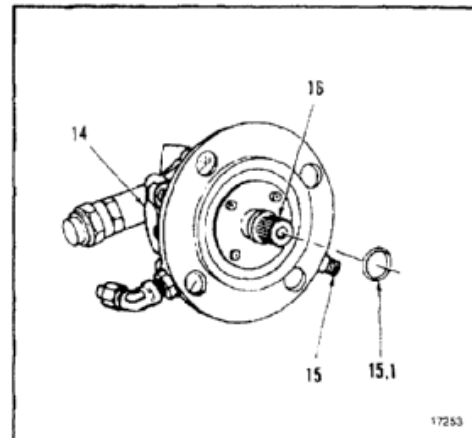

NOTE

When installing a Stratopower/ Dynapower pump there is a metal shim bonded to pump flange. If this shim comes unbounded from the pump flange. It does not have to be rebounded for installation.

9. Install gasket (16.1) on pump (16) and position pump (16) on four studs (17), with IN port (10) up. Wear gloves (E184.1).

WARNING

Oil (E254 or E254.1) is toxic. They can irritate skin and cause burns. Avoid inhaling. Use only with adequate ventilation. Avoid contact with skin, eyes, or clothing. In case of contact, immediately flush skin or eyes with water for at least **15 minutes**. Get medical attention for eyes.

10. Install four nuts (18). Torque nuts wet with oil (E254 or E254.1) to **70 to 100 inch-pounds**.

NOTE

Torque on nuts (18) must be checked for **85 inch-pounds** after the first flight. Do not back off nuts before torquing.

11. Remove cap and connect hose (19) to IN port (10).
12. Remove cap and connect hose (20) to OUT port (7).
13. Remove cap and connect hose (21) to port (15).
14. Remove cap and connect hose (22) to port (4).
15. Use cloths (E135) for any spilled fluid. Wear gloves (E184.1).

INSPECT**FOLLOW-ON MAINTENANCE:**

Service hydraulic reservoir (Task 1-62).
 Bleed utility hydraulic system (Task 7-336).
 Perform utility hydraulic pump operational check (TM 55-1520-240-T).
 Close right aft transmission access panel (Task 2-2).
 Close cargo ramp (TM 55-1520-240-T).

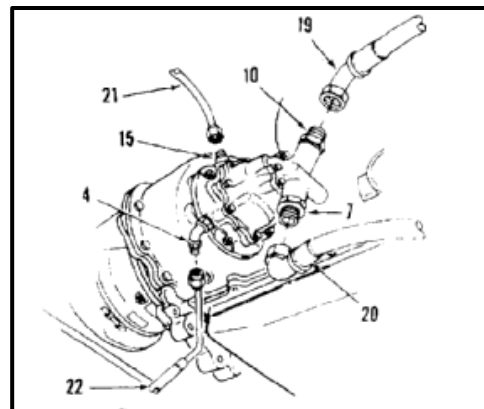
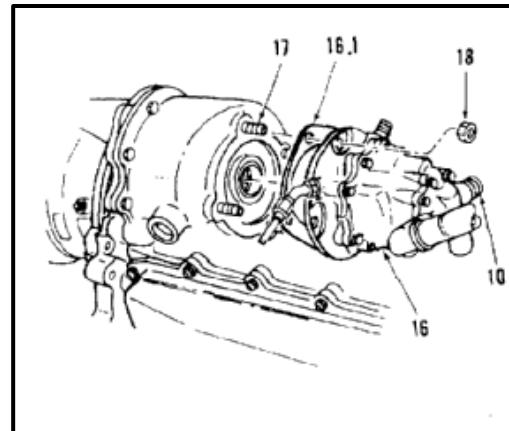

END OF TASK

INITIAL SETUP

Applicable Configurations:

All

Tools:

Aircraft Mechanic's Tool Kit, NSN 5180-00-323-4692
 Open-End Wrench, 1 Inch
 Open-End Wrench, 1-1/8 Inch
 Container, 2 Quart

Materials:

Cloths (E135)
 Paper Tags (E264)

Personnel Required:

Medium Helicopter Repairer (2)

Equipment Condition:

Battery Disconnected (Task 1-39)
 Electrical Power Off
 Hydraulic Power Off
 Utility Hydraulic System Depressurized (Task 7-135.1)
 Cargo Ramp Open and Level (TM 55-1520-240-T)

General Safety Instructions:**WARNING**

Hydraulic fluid (E199) is toxic. It can irritate skin and cause burns. Avoid inhaling. Use only with adequate ventilation. Avoid contact with skin, eyes, or clothing. In case of contact, immediately flush skin or eyes with water for at least **15 minutes**. Get medical attention for eyes.

WARNING

Hydraulic fluid ejected under pressure can cause injury to personnel. Hydraulic fluid sprayed into the air is a fire hazard.

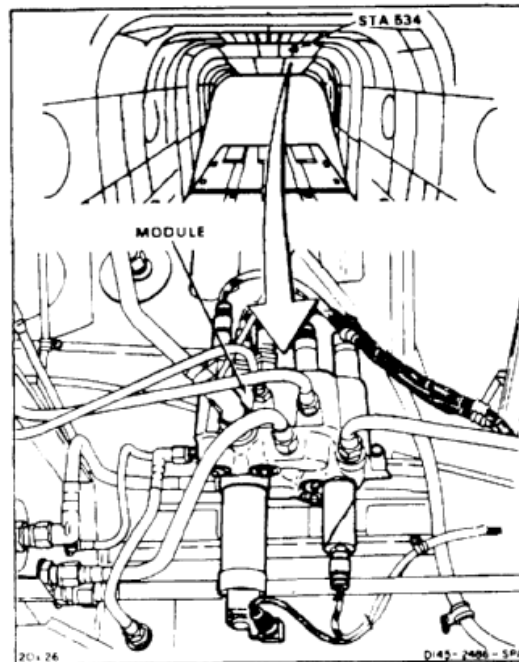

NOTE

The connector to the PTU PLT V solenoid valve may already be disconnected and tied back.

1. Tag and disconnect eight connectors (1) from module (2).
2. Tag and remove six tubes (3) from module (2). Use container and cloths (E135) for spilled fluid. Use gloves (E186).
3. Tag and disconnect three tubes (4) from module (2). Use container and cloths (E135) for spilled fluid.

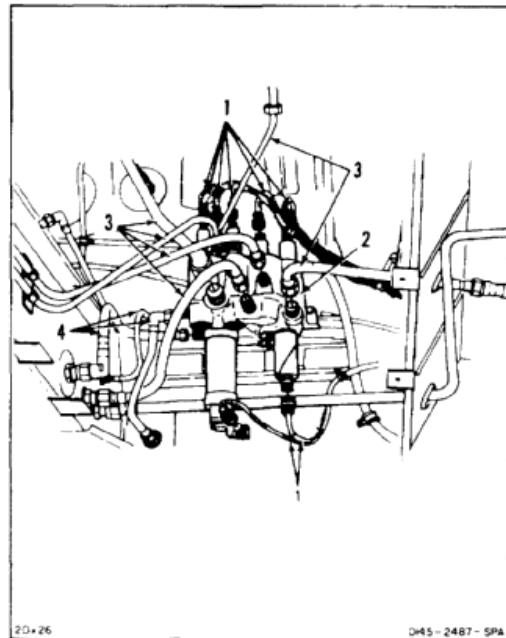

4. Have helper support module (2). Remove four bolts (5) and washers (6).
5. Remove module (2) carefully to avoid damage to tubing.

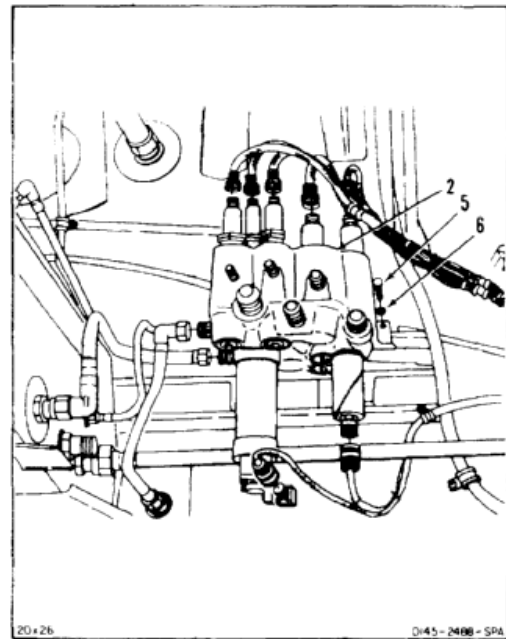
**FOLLOW-ON MAINTENANCE:**

None

END OF TASK

INITIAL SETUP

Applicable Configurations:

All

Tools:

Aircraft Mechanic's Tool Kit, NSN 5180-00-323-4692
 Open-End Wrench, 1 Inch
 Open-End Wrench, 1-1/8 Inch
 Open-End Wrench, 1-1/4 Inch

Materials:

Cloths (E135)
 Gloves (E184.1)

Personnel Required:

Medium Helicopter Repairer (2)
 Inspector

References:

TM 55-1520-240-23P

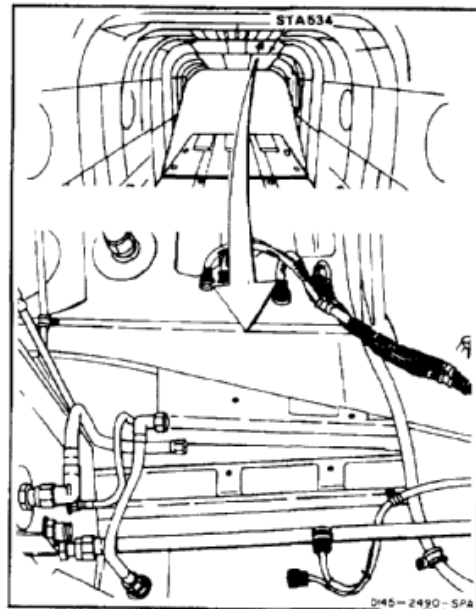

1. Position, and have helper support module (1). Install four bolts (2) and washers (3).
2. Connect tube (4) to APU PRESS port (5).
3. Connect tube (6) to RSVR RTN port (7).
4. Connect tube (8) to EXT PWR SUPPLY port (9).
5. Connect tube (10) to RAMP PRESS port (11) and tube (12).
6. Connect tube (13) to BK STRG PRESS port (14) and fitting (15).
7. Connect tube (16) to PTU PRESS port (17) and fitting (18).

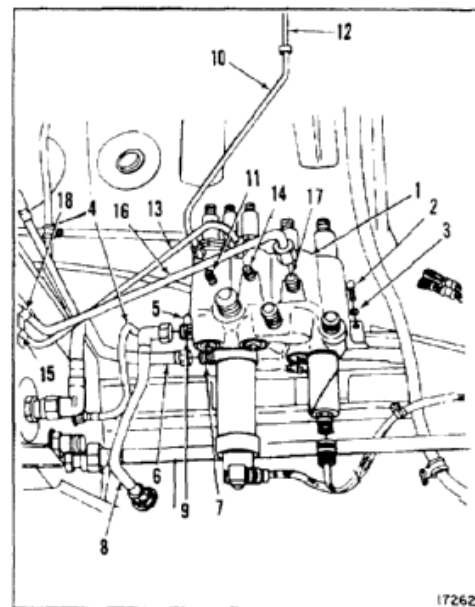

8. Connect tube (4) to LH ENG START PRESS port (19) and fitting (20). Remove tag.
9. Connect tube (7) to RH ENG START PRESS port (21) and fitting (22). Remove tag.
10. Connect tube (23) to PRESS INL port (24) and fitting (25). Remove tag.
11. Deleted.

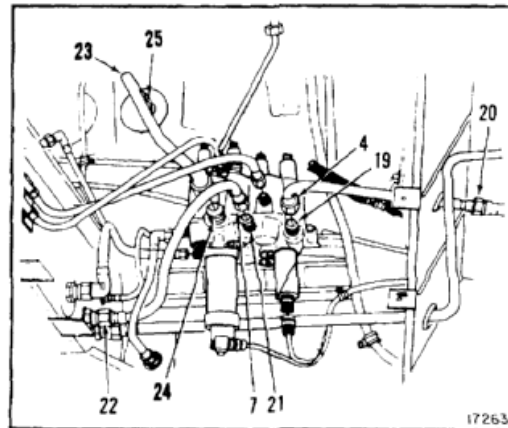

CAUTION

Electrical connectors are to be tightened no more than **1/16 to 1/8 turn** beyond finger-tight during installation, otherwise they will be damaged.

12. Connect connector (28) PRESS XMTR to transmitter (29). Remove tag.
13. Connect connector (30) to filter indicator (31). Remove tag.
14. Connect connector (32) to PRESS SWITCH (33). Remove tag.
15. Connect connector (34) to RAMP PWR V (35). Remove tag.
16. Connect connector (36) to RH ENG PLT V (37). Remove tag.
17. Connect connector (38) to PTU PWR CV valve (39). Remove tag.
18. Connect connector (40) to WHLBK PWR V valve (41). Remove tag.
19. Check PTU PWR V valve (43) if part number is 145HS204-3. Connect connector (42) to valve (43). Remove tag. If part number is 145HS204-1, do not connect connector.

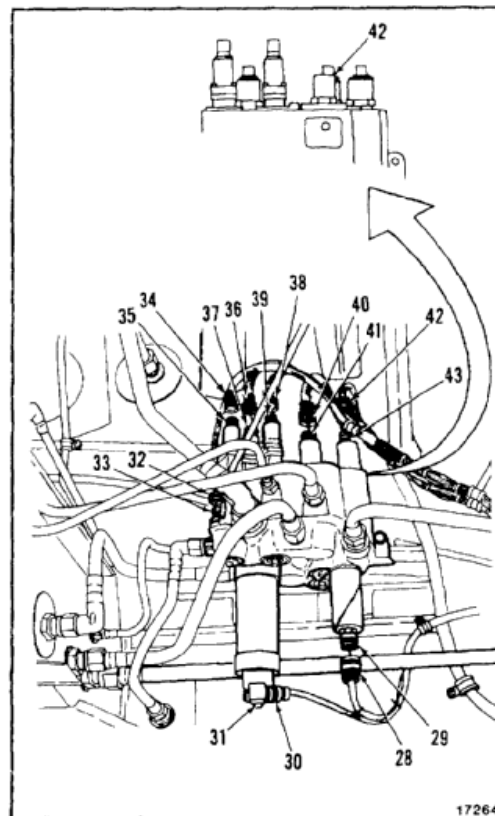

INSPECT

FOLLOW-ON MAINTENANCE:

- Bleed utility hydraulic system (Task 7-336).
- Perform operational check (TM 55-1520-240-T).
- Close cargo ramp (TM 55-1520-240-T).

END OF TASK

INITIAL SETUP

Applicable Configurations:

All

Tools:

Aircraft Mechanic's Tool Kit, NSN 5180-00-323-4692
 Socket, 1-3/8 Inch
 Container, 2 Quart

Materials:

Cloths (E135)
 Gloves (E186)

Personnel Required:

Medium Helicopter Repairer

Equipment Condition:

Battery Disconnected (Task 1-39)
 Electrical Power Off
 Hydraulic Power Off
 Utility Hydraulic System Depressurized (Task 7-135.1)
 Cargo Ramp Open and Level (TM 55-1520-240-T)

General Safety Instructions:**WARNING**

Hydraulic fluid (E199) is toxic. It can irritate skin and cause burns. Avoid inhaling. Use only with adequate ventilation. Avoid contact with skin, eyes, or clothing. In case of contact, immediately flush skin or eyes with water for at least **15 minutes**. Get medical attention for eyes.

WARNING

Hydraulic fluid ejected under pressure can cause injury to personnel. Hydraulic fluid sprayed into the air is a fire hazard.

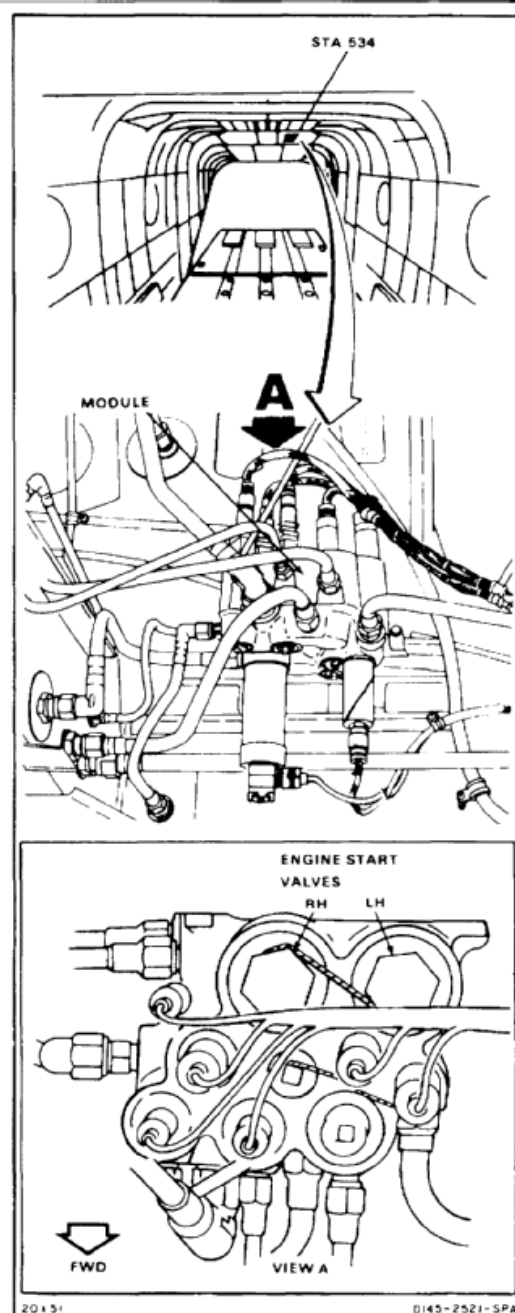

NOTE

Procedure is same to remove LH or RH or start valve. LH valve is shown.

1. Remove lockwire from valve (1).
2. Remove valve (1), four packings (2), and eight retainers (3). Use container and cloths (E135) for spilled fluid. Use gloves (E186).

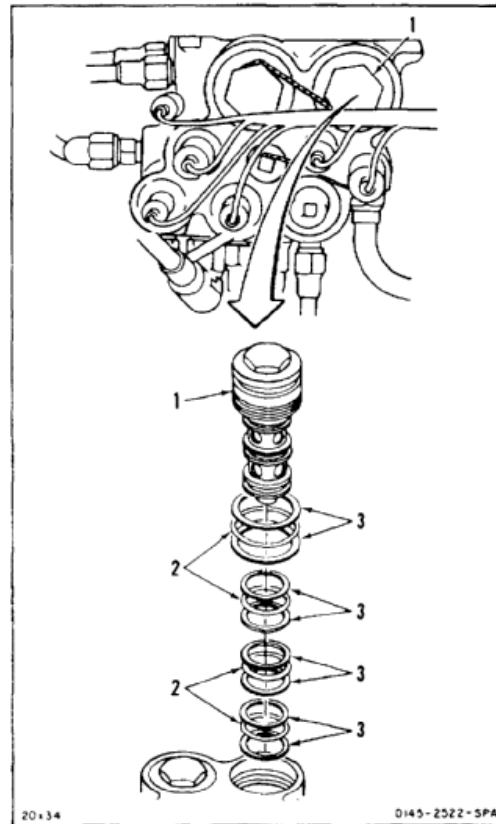
**FOLLOW-ON MAINTENANCE:**

None

END OF TASK

INITIAL SETUP

Applicable Configurations:

All

Tools:

Aircraft Mechanic's Tool Kit, NSN 5180-00-323-4692
 Socket, 1-3/8 Inch

Materials:

Cloths (E135)
 Lockwire (E231)

Parts:

Preformed Packings
 Retainers

Personnel Required:

Medium Helicopter Repairer
 Inspector

References:

TM 55-1520-240-23P

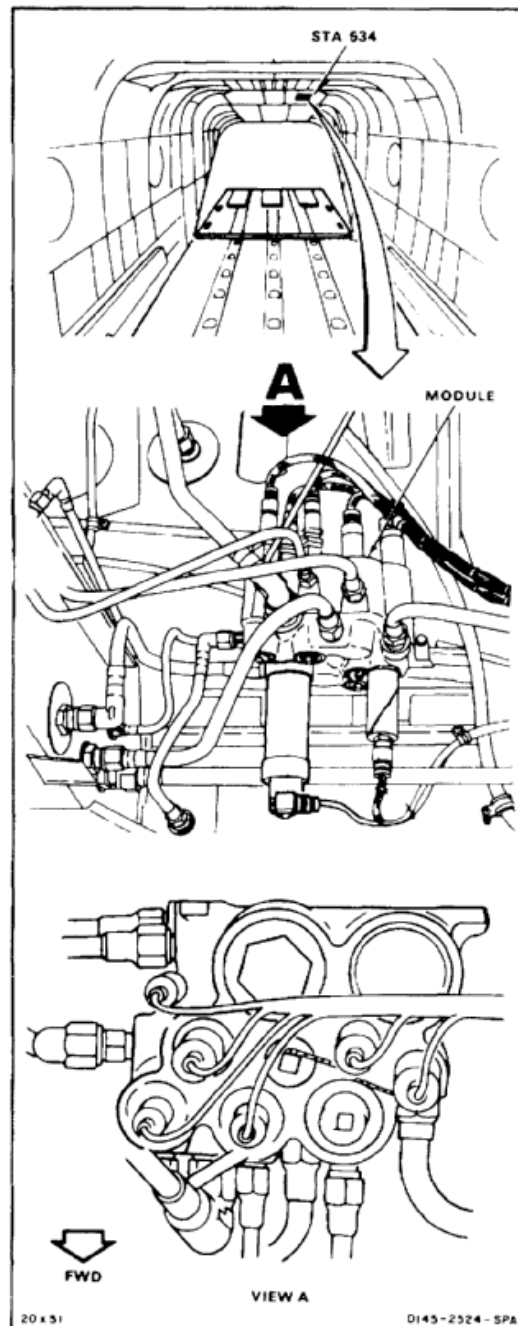

NOTE

Procedure is same to install LH or RH start valve. LH valve is shown here.

1. Install two retainers (1), packing (2), six retainers (3), and three packings (4) on valve (5).
2. Install valve (5) in port (6). Use **1-3/8 inch** socket. Use cloths (E135) for spilled fluid.
3. Lockwire valve (5) to valve (7). Use lockwire (E231).

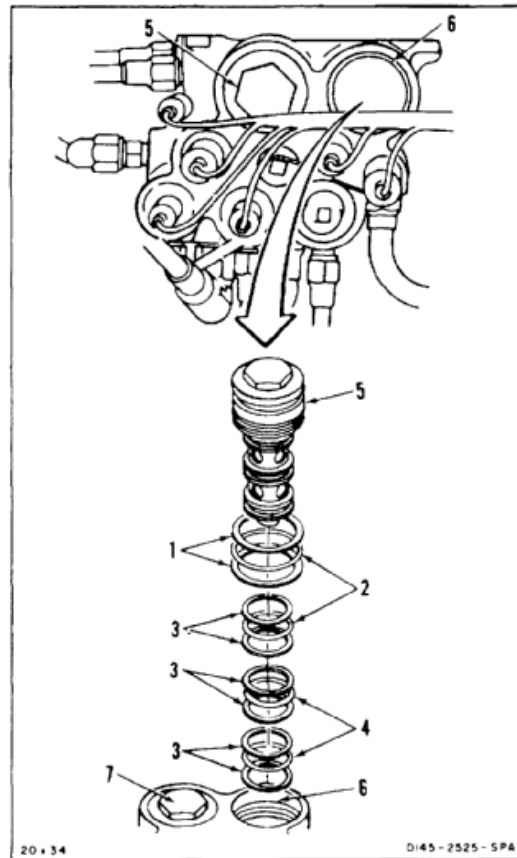
INSPECT**FOLLOW-ON MAINTENANCE:**

- Perform functional check (TM 55-1520-240-T).
- Bleed utility hydraulic reservoir (Task 7-335).

END OF TASK

INITIAL SETUP

Applicable Configurations:

All

Tools:

Aircraft Mechanic's Tool Kit, NSN 5180-00-323-4692
Container, 2 Quart

Materials:

Cloths (E135)
Gloves (E186)

Personnel Required:

Medium Helicopter Repairer

Equipment Condition:

Battery Disconnected (Task 1-39)
Electrical Power Off
Hydraulic Power Off
Cargo Ramp Open and Level (TM 55-1520-240-T)
Utility Hydraulic System Depressurized (Task 7-135.1)

References:

Task 7-349

General Safety Requirements:**WARNING**

Hydraulic fluid (E199) is toxic. It can irritate skin and cause burns. Avoid inhaling. Use only with adequate ventilation. Avoid contact with skin, eyes, or clothing. In case of contact, immediately flush skin or eyes with water for at least **15 minutes**. Get medical attention for eyes.

WARNING

Hydraulic fluid ejected under pressure can cause injury to personnel. Hydraulic fluid sprayed into the air is a fire hazard.

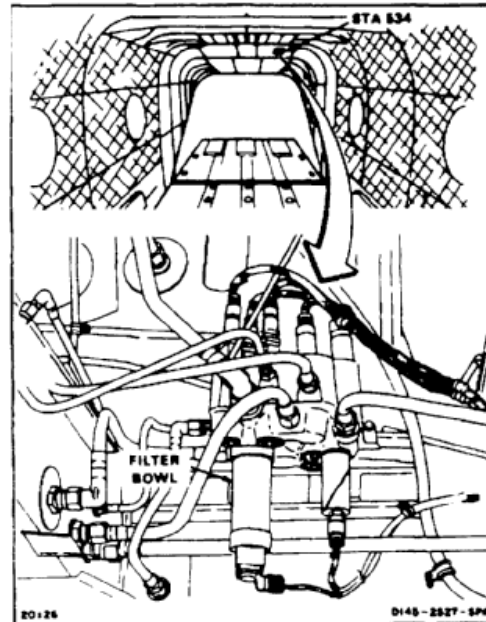

NOTE

If diaphragm must be removed, refer to Task 7-349.

1. Remove lockwire and disconnect connector (1) from indicator (2).
2. Remove lockwire from filter bowl (3). Remove bowl from filter port (4). Use container and cloths (E135) for spilled fluid. Use gloves (E186).
- 2.1. Remove retainer (4.1) and packings (4.2 and 4.3).

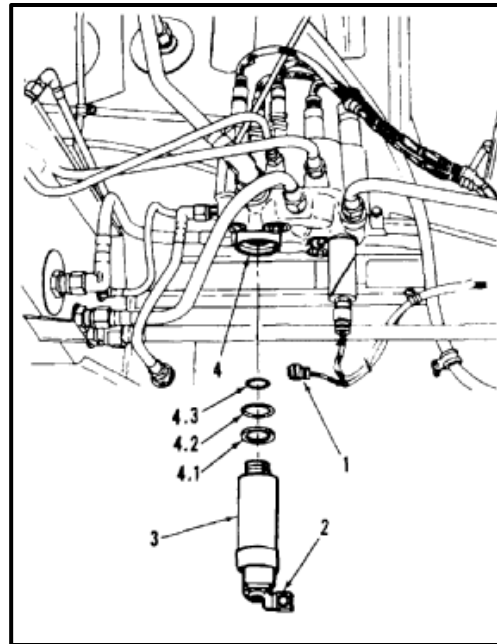

3. Remove filter element (5) from bowl (3). Discard filter.

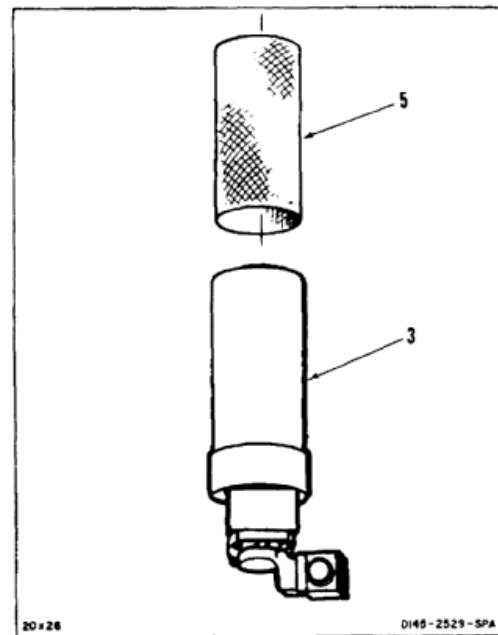
**FOLLOW-ON MAINTENANCE:**

None

END OF TASK

INITIAL SETUP

Applicable Configurations:

All

Tools:

Aircraft Mechanic's Tool Kit, NSN 5180-00-323-4692

Materials:

Cloths (E135)
Lockwire (E231)

Parts:

Filter Element
Preformed Packings
Retainer

Personnel Required:

Medium Helicopter Repairer
Inspector

References:

TM 55-1520-240-23P

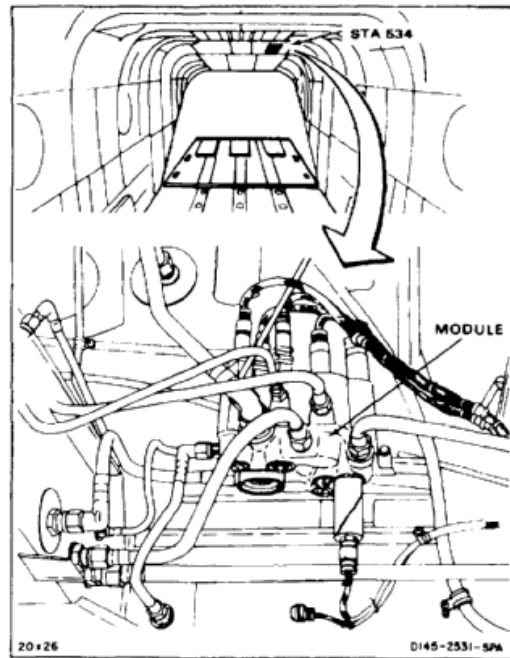

NOTE

If diaphragm was removed, refer to Task 7-349 for proper installation.

1. Install filter element (1) in bowl (2).

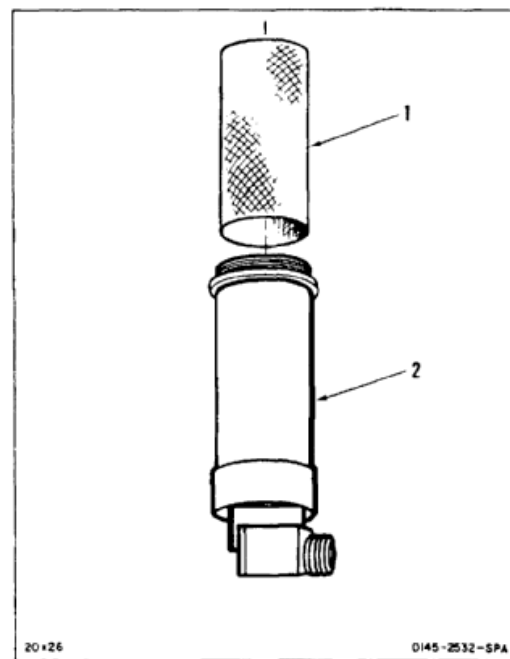

- 1.1. Install packings (2.1 and 2.2) and retainer (2.3) in FILTER port (3).
2. Install bowl (2) in FILTER port (3). Tighten hand tight. Use cloths (E135) for spilled fluid.



Electrical connectors are to be tightened no more than **1/16 to 1/8 turn** beyond finger-tight during installation, otherwise they will be damaged.

3. Connect connector (4) to indicator (5).
4. Lockwire bowl (2) to module (6). Use lockwire (E231).

INSPECT

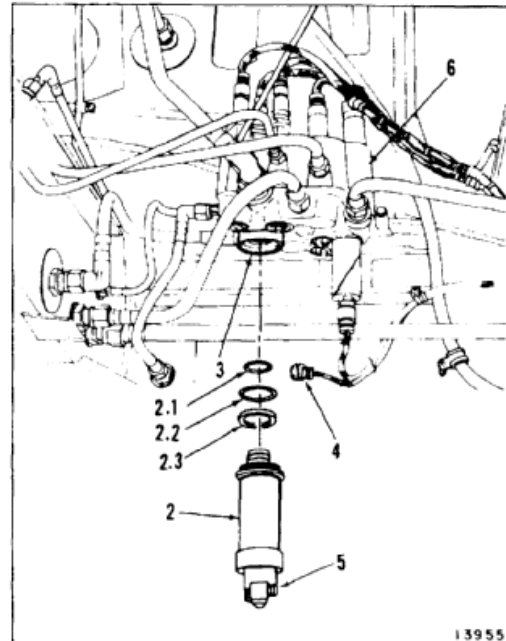

FOLLOW-ON MAINTENANCE:

Perform operation check (TM 55-1520-240-T).

END OF TASK

INITIAL SETUP

Applicable Configurations:

All

Tools:

Aircraft Mechanic's Tool Kit, NSN 5180-00-323-4692
 Container, 2 Quart

Materials:

Cloths (E135)
 Gloves (E186)

Personnel Required:

Medium Helicopter Repairer

Equipment Condition:

Battery Disconnected (Task 1-39)
 Electrical Power Off
 Hydraulic Power Off
 Utility Hydraulic System Depressurized (Task 7-135.1)
 Cargo Ramp Open and Level (TM 55-1520-240-10)

General Safety Instructions:

WARNING

Hydraulic fluid (E199) is toxic. It can irritate skin and cause burns. Avoid inhaling. Use only with adequate ventilation. Avoid contact with skin, eyes, or clothing. In case of contact, immediately flush skin or eyes with water for at least **15 minutes**. Get medical attention for eyes.

WARNING

Hydraulic fluid ejected under pressure can cause injury to personnel. Hydraulic fluid sprayed into the air is a fire hazard.

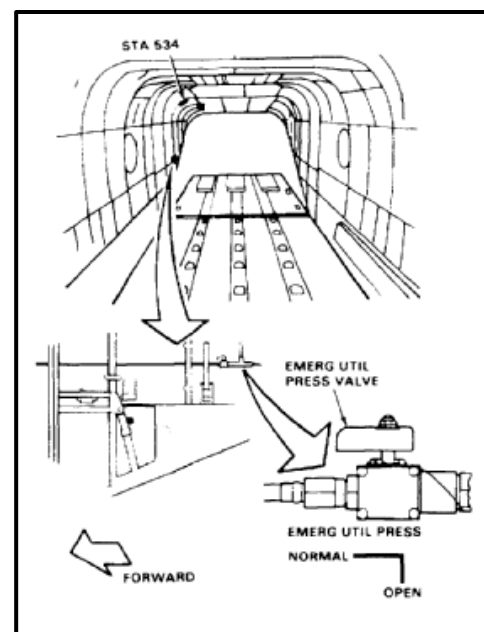
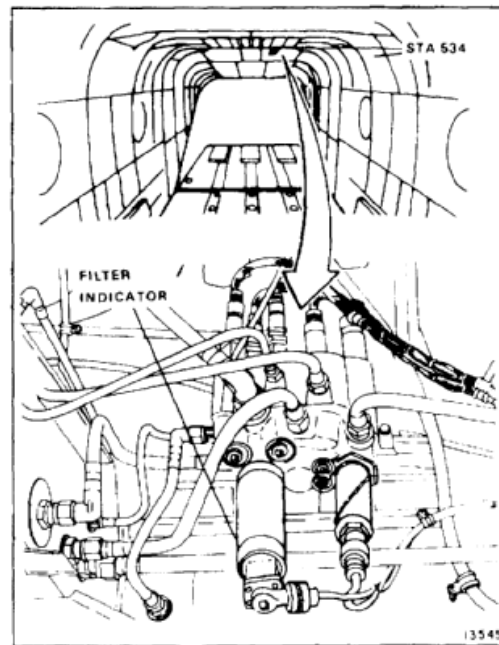

1. Disconnect connector (1) from indicator (2).
2. Remove lockwire from four screws (3). Remove four screws.
3. Remove indicator (2), retainer (4) and two packings (5) from filter bowl (6). Use container and cloths (E135) for spilled fluid. Use gloves (E186).

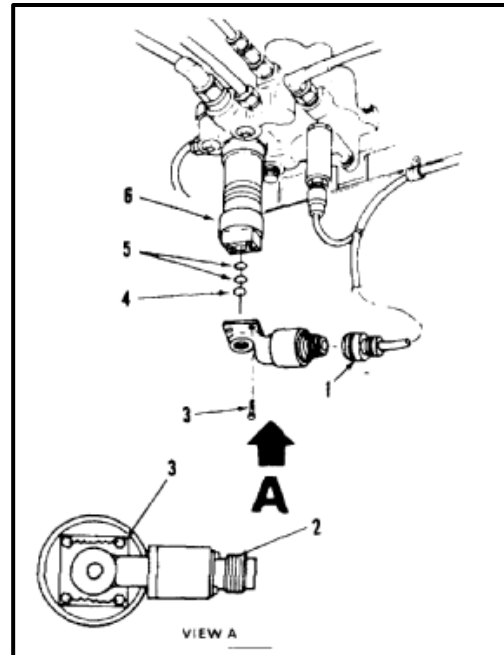
**FOLLOW-ON MAINTENANCE:**

None

END OF TASK

INITIAL SETUP

Applicable Configurations:

All

Tools:

Aircraft Mechanic's Tool Kit, NSN 5180-00-323-4692
Torque Wrench, 0 to 150 Inch-Pounds

Materials:

Cloths (E135)
Lockwire (E231)

Parts:

Preformed Packings
Retainer

Personnel Required:

Medium Helicopter Repairer
Inspector

References:

TM 55-1520-240-23P

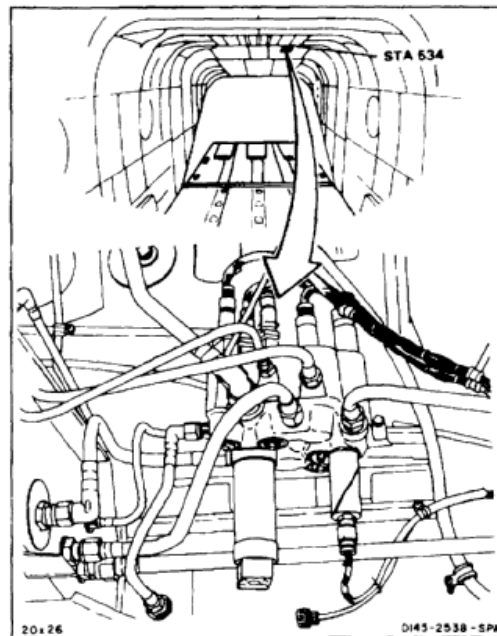

1. Position indicator (1), retainer (2), and two packings (3) in FILTER bowl (4). Use cloths (E135) for spilled fluid.
2. Lubricate and install four screws (5) in indicator (1). Torque screws to **33 inch-pounds** in diagonal sequence. Lockwire screws. Use lockwire (E231).



Electrical connectors are to be tightened no more than **1/16 to 1/8 turn** beyond finger-tight during installation, otherwise they will be damaged.

3. Connect connector (6) to indicator (1).

INSPECT

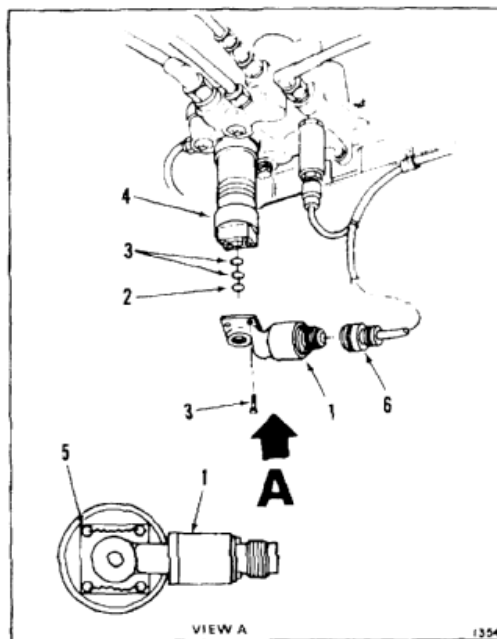

FOLLOW-ON MAINTENANCE:

Perform operational check (TM 55-1520-240-T).
Bleed utility hydraulic reservoir (Task 7-335).

END OF TASK

INITIAL SETUP

Applicable Configurations:

All

Tools:

Aircraft Mechanic's Tool Kit, NSN 5180-00-323-4692
 Crowfoot, 1 Inch
 Container, 2 Quart

Materials:

Cloths (E135)
 Gloves (E186)

Personnel Required:

Medium Helicopter Repairer

Equipment Condition:

Battery Disconnected (Task 1-39)
 Electrical Power Off
 Hydraulic Power Off
 Utility Hydraulic System Depressurized (Task 7-135.1)
 Cargo Ramp Open and Level (TM 55-1520-240-10)

General Safety Instructions:**WARNING**

Hydraulic fluid (E199) is toxic. It can irritate skin and cause burns. Avoid inhaling. Use only with adequate ventilation. Avoid contact with skin, eyes, or clothing. In case of contact, immediately flush skin or eyes with water for at least **15 minutes**. Get medical attention for eyes.

WARNING

Hydraulic fluid ejected under pressure can cause injury to personnel. Hydraulic fluid sprayed into the air is a fire hazard.

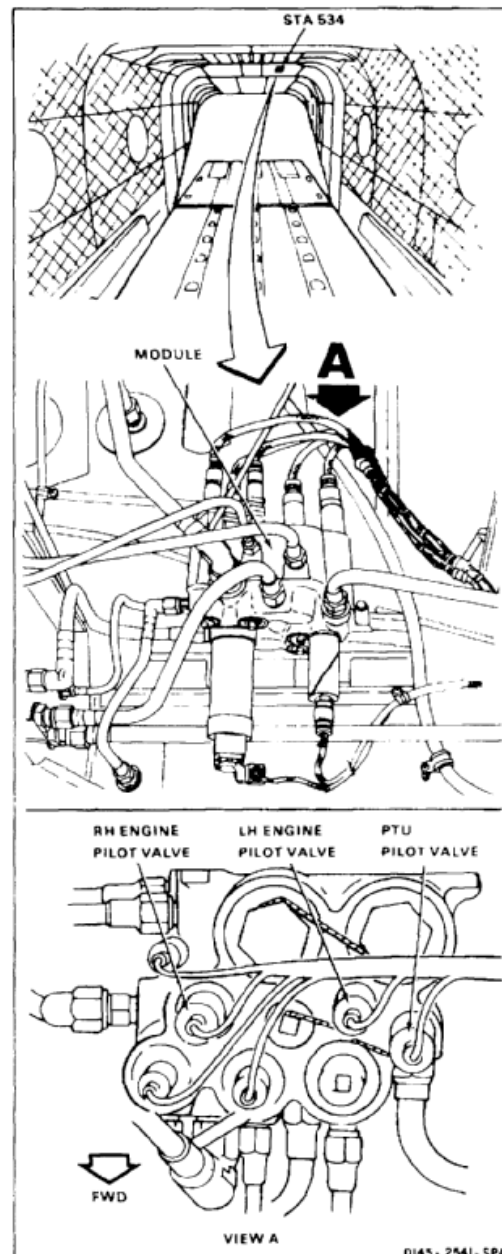

NOTE

Procedure is same to remove RH ENG, LH ENG, or PTU pilot valves. PTU valve is shown here.

1. Disconnect connector (1) from valve (2).

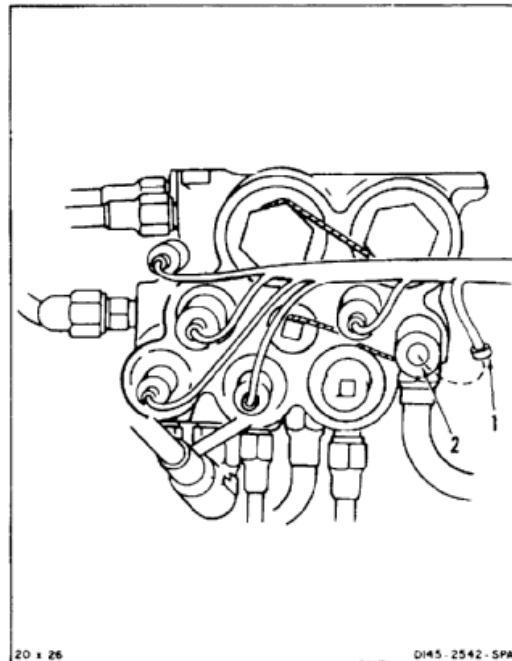

2. Remove lockwire from valve (2). Remove valve, three packings (3), and four retainers (4) from valve port (5). Use container and cloths (E135) for spilled fluid. Use gloves (E186).

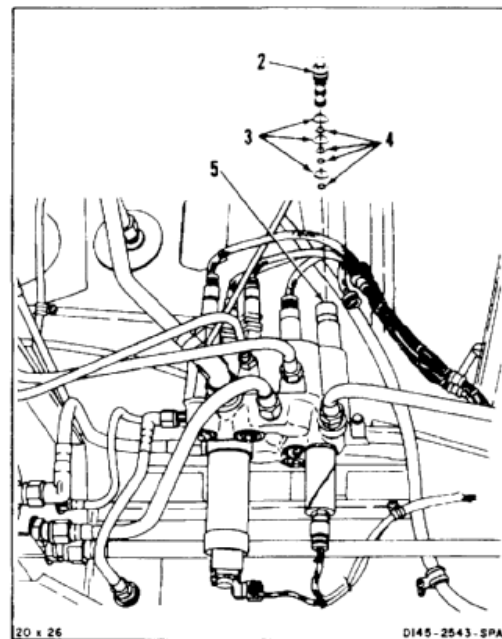
**FOLLOW-ON MAINTENANCE:**

None

END OF TASK

7-688

INITIAL SETUP

Applicable Configurations:

All

Tools:

Aircraft Mechanic's Tool Kit, NSN 1580-00-323-4692
Wrench, 1 Inch

Materials:

Cloths (E135)
Lockwire (E231)

Parts:

Preformed Packings
Retainers

Personnel Required:

Medium Helicopter Repairer
Inspector

References:

TM 55-1520-240-23P

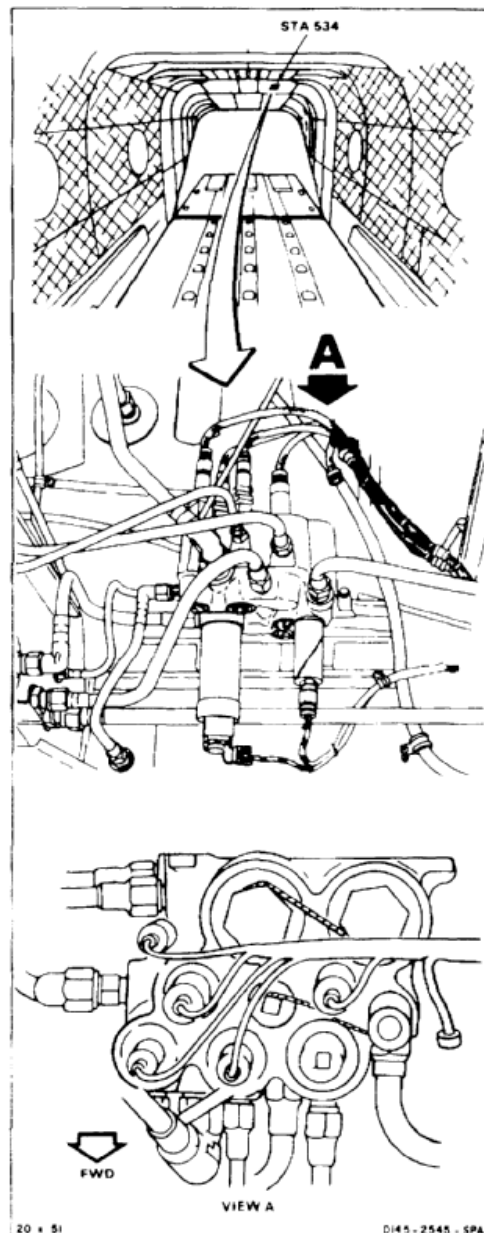

NOTE

Procedure is same to install RH ENG, LH ENG or PTU pilot valves. PTU valve is shown here.

1. Install valve (1), three packings (2), and two retainers (3) in port (4).
2. Lockwire valve (1) with lockwire (E231).



Electrical connectors are to be tightened no more than **1/16 to 1/8 turn** beyond finger-tight during installation, otherwise they will be damaged.

3. Connect connector (5) to valve (1).

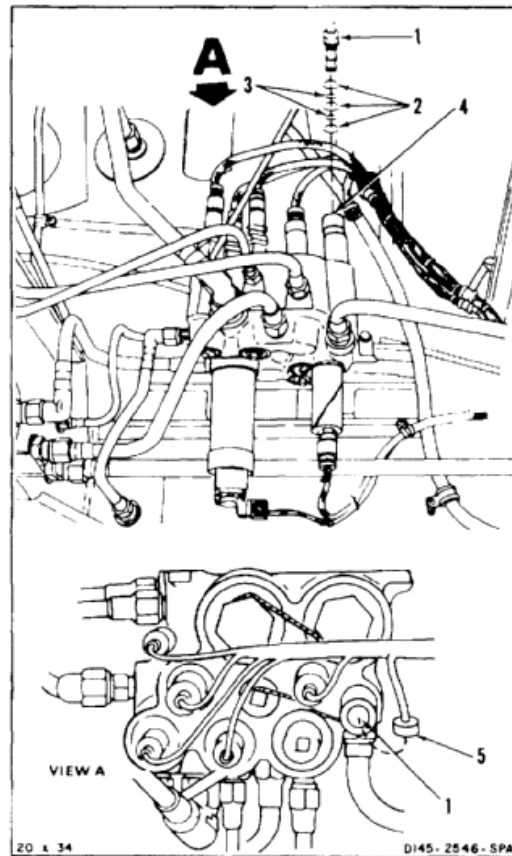
INSPECT**FOLLOW-ON MAINTENANCE:**

- Perform operational check (TM 55-1520-240-T).
- Bleed utility hydraulic reservoir (Task 7-335).

END OF TASK

INITIAL SETUP

Applicable Configurations:

All

Tools:

Aircraft Mechanic's Tool Kit, NSN 51 80-00-323-4692
Container, 2 Quart

Materials:

Cloths (E135)
Gloves (E186)

Personnel Required:

Medium Helicopter Repairer

Equipment Condition:

Battery Disconnected (Task 1-39)
Electrical Power Off
Hydraulic Power Off
Utility Hydraulic System Depressurized (Task 7-135.1)
Cargo Ramp Open and Level (TM 55-1520-240-T)

General Safety Instructions:**WARNING**

Hydraulic fluid (E199) is toxic. It can irritate skin and cause burns. Avoid inhaling. Use only with adequate ventilation. Avoid contact with skin, eyes, or clothing. In case of contact, immediately flush skin or eyes with water for at least **15 minutes**. Get medical attention for eyes.

WARNING

Hydraulic fluid ejected under pressure can cause injury to personnel.
Hydraulic fluid sprayed into the air is a fire hazard.

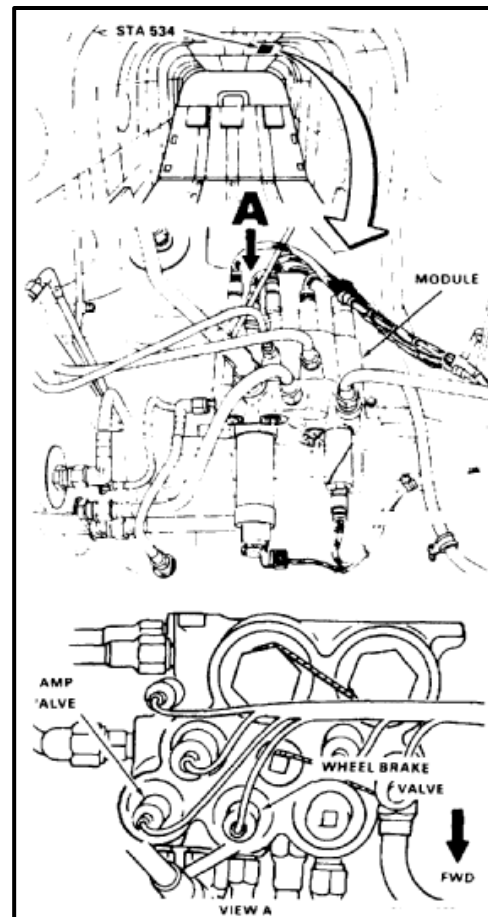

NOTE

Procedure is same to remove ramp control or wheel brake control valve. Ramp control valve is shown here.

1. Disconnect connector (1) from valve (2).

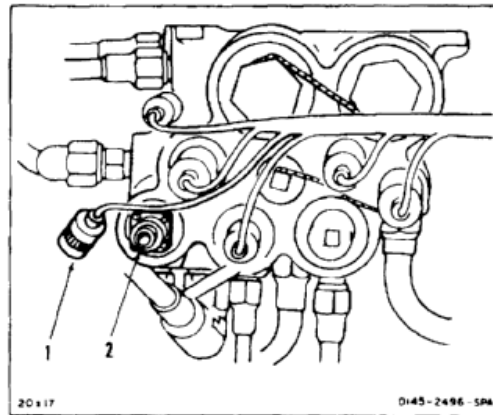

2. Remove lockwire and valve (2), three packings (3), and six retainers (4). Use container and cloths (E135) for spilled fluid. Use gloves (E186).

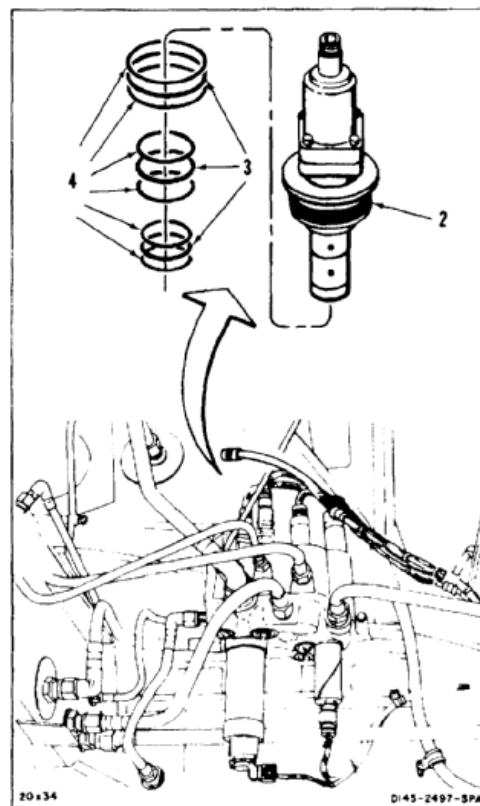

FOLLOW-ON MAINTENANCE:

None

END OF TASK

INITIAL SETUP

Applicable Configurations:

All

Tools:

Aircraft Mechanic's Tool Kit, NSN 51 80-00-323-4692

Materials:Cloths (E135)
Lockwire (E231)**Parts:**Preformed Packings
Retainers**Personnel Required:**Medium Helicopter Repairer
Inspector**References:**

TM 55-1520-240-23P

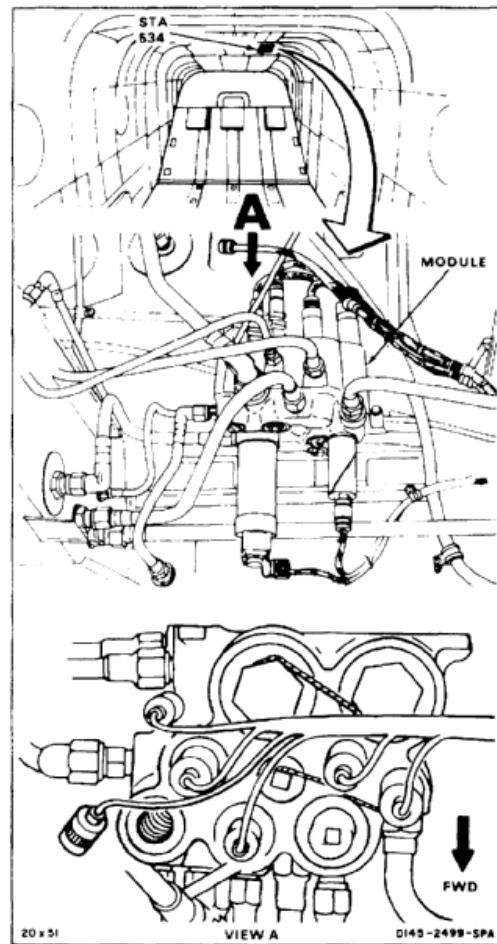

NOTE

Procedure is same to install ramp control or wheel brake control valve.
Ramp control valve is shown here.

1. Install valve (1), three packings (2), and six retainers (3) in RAMP PWR V port (4). Use cloths (E135) for spilled fluid.
2. Lockwire valve (1) with lockwire (E231).



Electrical connectors are to be tightened to more than **1/16 to 1/8 turn** beyond finger-tight during installation, otherwise they will be damaged.

3. Connect connector (5) to valve (1).

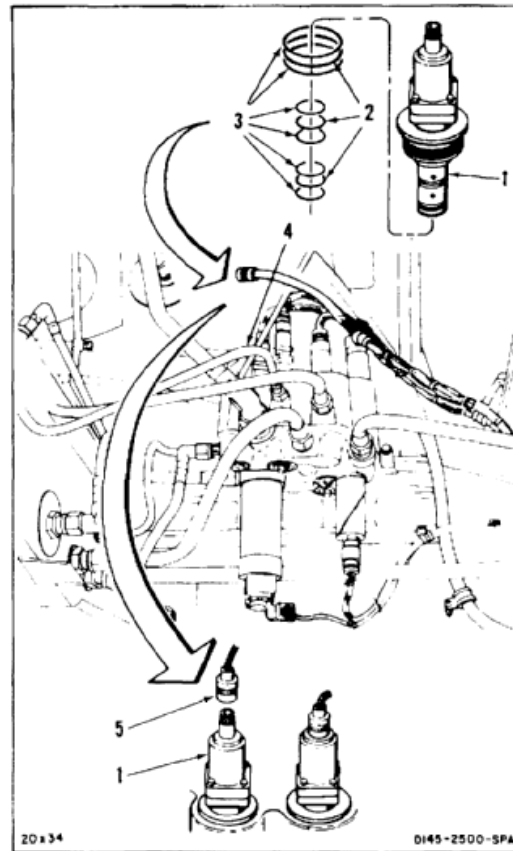
INSPECT**FOLLOW-ON MAINTENANCE:**

Perform operational check (TM 55-1520-240-T).
Bleed utility hydraulic reservoir (Task 7-335).
Close cargo ramp (TM 55-1520-240-T).

END OF TASK

INITIAL SETUP

Applicable Configurations:

All

Tools:

Aircraft Mechanic's Tool Kit, NSN 51 80-00-323-4692
 Container, 2 Quart

Materials:

Cloths (E135)
 Gloves (E186)

Personnel Required:

Medium Helicopter Repairer

Equipment Condition:

Battery Disconnected (Task 1-39)
 Electrical Power Off
 Hydraulic Power Off
 Cargo Ramp Open And Level (TM 55-1520-240-T)

General Safety Requirements:

WARNING

Hydraulic fluid (E199) is toxic. It can irritate skin and cause burns. Avoid inhaling. Use only with adequate ventilation. Avoid contact with skin, eyes, or clothing. In case of contact, immediately flush skin or eyes with water for at least **15 minutes**. Get medical attention for eyes.

WARNING

Hydraulic fluid ejected under pressure can cause injury to personnel. Hydraulic fluid sprayed into the air is a fire hazard.

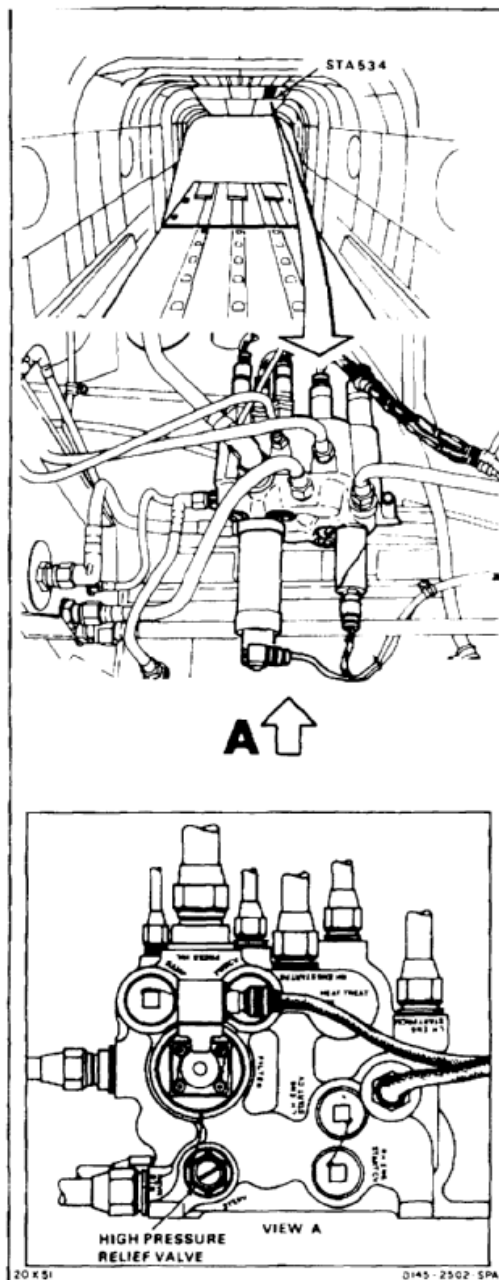

1. Remove lockwire from valve (1).
2. Remove valve (1), two retainers (2), and two packings (3) from port (4). Use container and cloths (E135) for spilled fluid. Use gloves (E186).

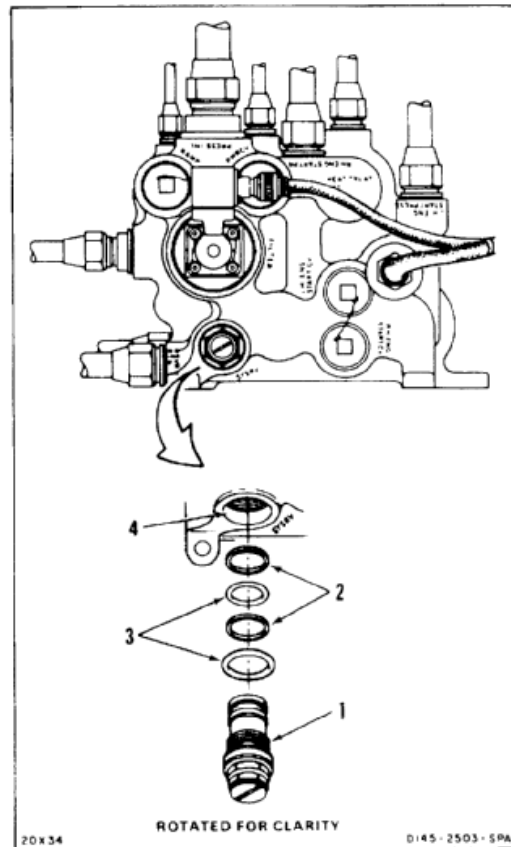
**FOLLOW-ON MAINTENANCE:**

None

END OF TASK

7-696

INITIAL SETUP

Applicable Configurations:

All

Tools:

Aircraft Mechanic's Tool Kit, NSN 51 80-00-323-4692

Materials:

Lockwire (E231)

Parts:

Preformed Packings
Retainers

Personnel Required:

Medium Helicopter Repairer
Inspector

References:

TM 55-1520-240-23P

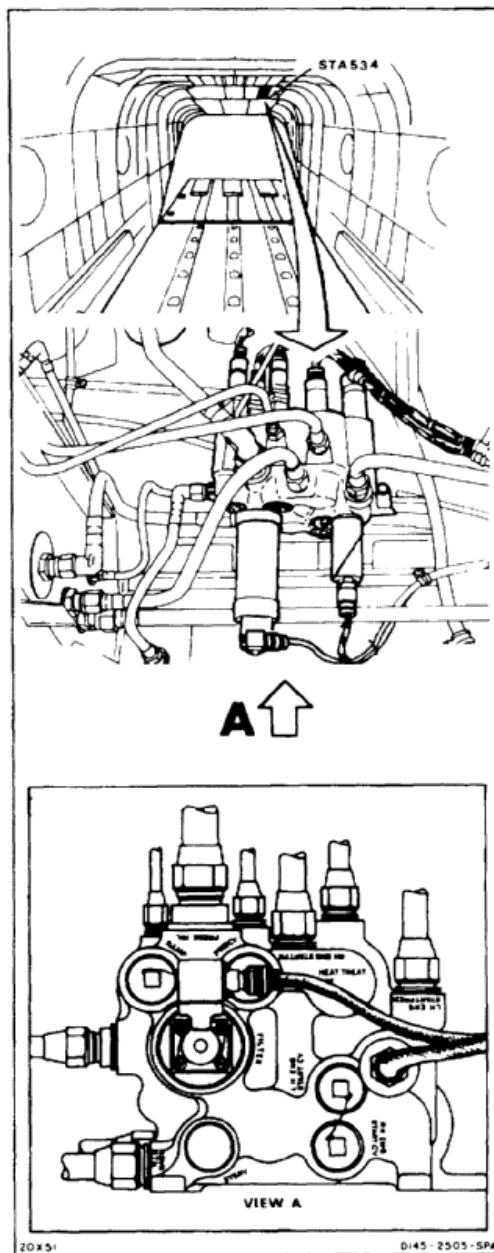

1. Install packing (1), two packings (3), on valve (4).
2. Install valve (4) in SYSRV port (5).
3. Lockwire valve (4). Use lockwire (E231).

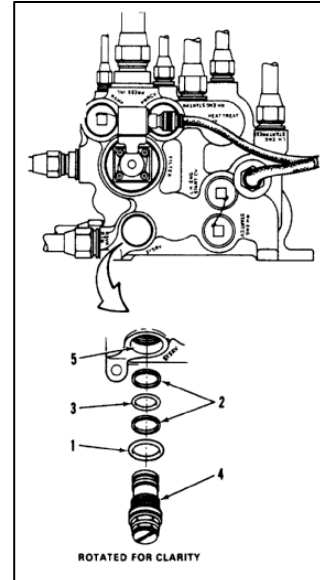
INSPECT***FOLLOW-ON MAINTENANCE:***

- Perform operational check (TM 55-1520-240-T).
- Bleed utility hydraulic reservoir (Task 7-336).

END OF TASK

INITIAL SETUP

General Safety Instructions:

Applicable Configurations:

All

Tools:

Aircraft Mechanic's Tool Kit, NSN 5180-00-323-4692
 Container, 2 Quart

Materials:

Cloths (E135)
 Gloves (E186)

Personnel Required:

Medium Helicopter Repairer

Equipment Condition:

Battery Disconnected (Task 1-39)
 Electrical Power Off
 Hydraulic Power Off
 Utility Hydraulic System Depressurized (Task 7-135.1)
 Cargo Ramp Open and Level (TM 55-1520-240-10)

WARNING

Hydraulic fluid (E199) is toxic. It can irritate skin and cause burns. Avoid inhaling. Use only with adequate ventilation. Avoid contact with skin, eyes, or clothing. In case of contact, immediately flush skin or eyes with water for at least **15 minutes**. Get medical attention for eyes.

WARNING

Hydraulic fluid ejected under pressure can cause injury to personnel. Hydraulic fluid sprayed into the air is a fire hazard.

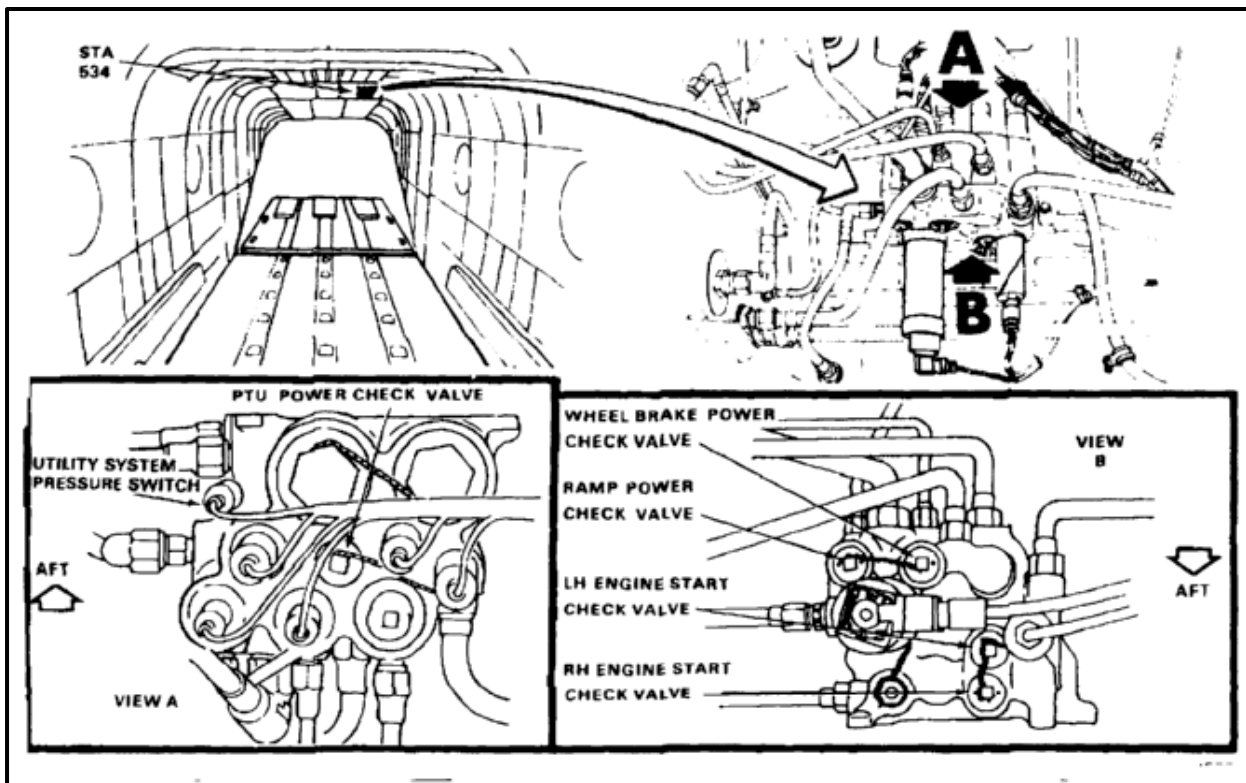

NOTE

Procedure is same to remove PTU, wheel brake, ramp power, LH engine start, or RH engine start check valves. RH engine start valve is shown here.

1. Remove lockwire from valve (1). Remove valve, two packings (2), and four retainers (3) from RH ENG START CV port (4). Use container and cloths (E135) for spilled fluid. Use gloves (E186).

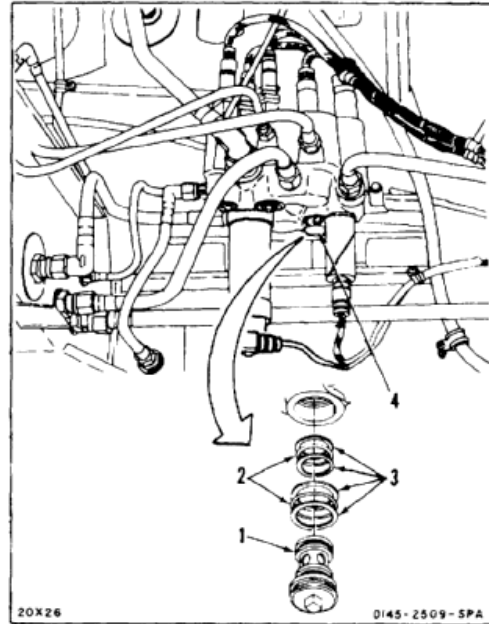
**FOLLOW-ON MAINTENANCE:**

None

END OF TASK

7-700

7-167 INSTALL PRESSURE CONTROL MODULE CHECK VALVES

7-167

INITIAL SETUP

Applicable Configurations:

All

Tools:

Aircraft Mechanic's Tool Kit, NSN 5180-00-323-4692

Materials:

Cloths (E135)
Lockwire (E231)

Parts:

Preformed Packings
Retainers

Personnel Required:

Medium Helicopter Repairer
Inspector

References:

TM 55-1520-240-23P

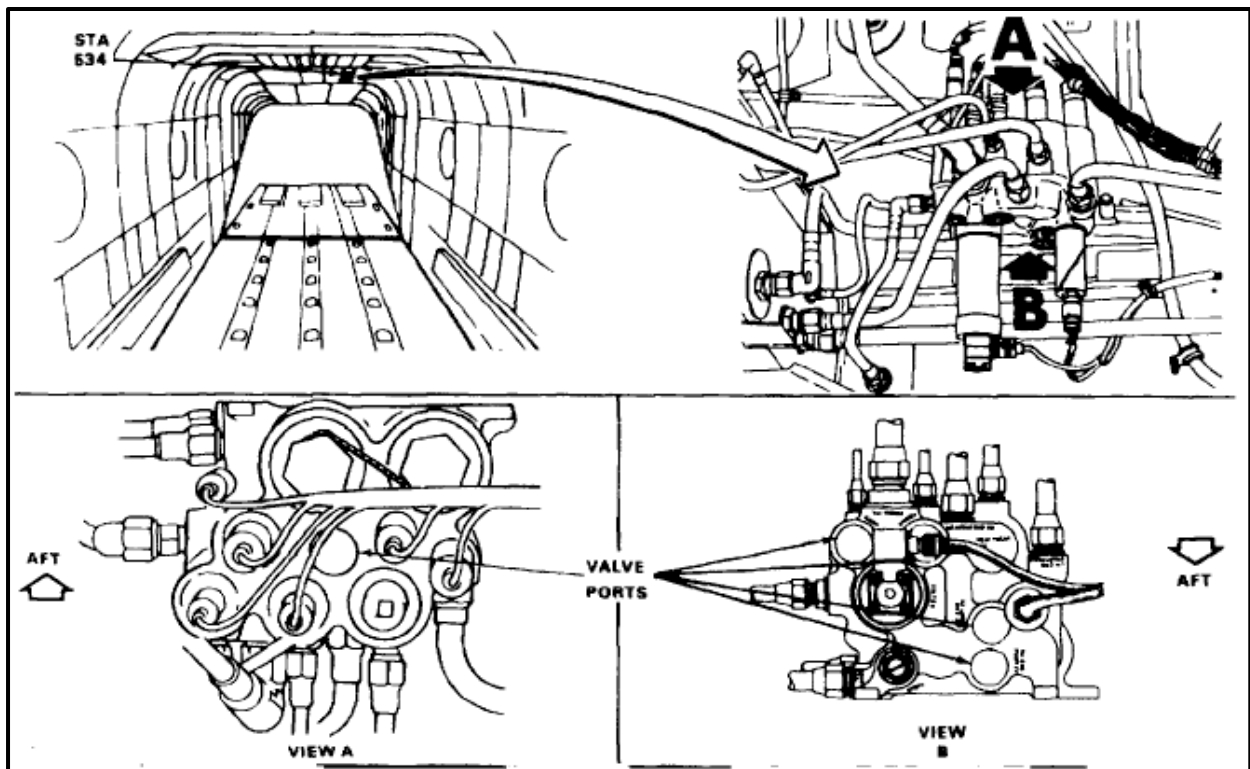

NOTE

Procedure is same to install PTU, wheel brake, ramp power, LH engine start or RH engine start check valves. RH engine start valve is shown here.

1. Install two retainers (1), packing (2), two retainers (3), and packing (4) on valve (5).
2. Install valve (5), in RH ENG START CB port (6). Use cloths (E135) for spilled fluid.
3. Lockwire valve (5). Use lockwire (E231).

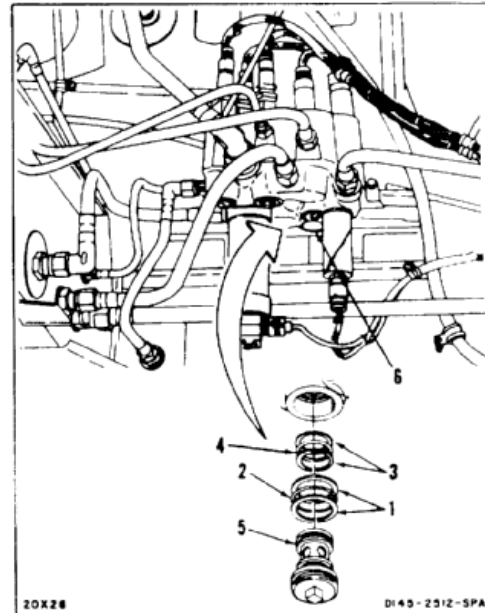
INSPECT**FOLLOW-ON MAINTENANCE:**

Perform operational check (TM 55-1520-240-T).
Bleed utility hydraulic reservoir (Task 7-336).

END OF TASK

7-702

7-167.1 REMOVE UTILITY SYSTEM PRESSURE SWITCH

7-167.1

INITIAL SETUP**Applicable Configurations:**

All

Tools:

Aircraft Mechanic's Tool Kit, NSN 51 80-00-323-4692

Materials:

None

Personnel Required:

Medium Helicopter Repairer

Equipment Condition:

Battery Disconnected (Task 1-39)

Electrical Power Off

Hydraulic Power Off

Utility Hydraulic System Depressurized (Task 7-135.1)

Cargo Ramp Open and Level (TM 55-1520-240-T)

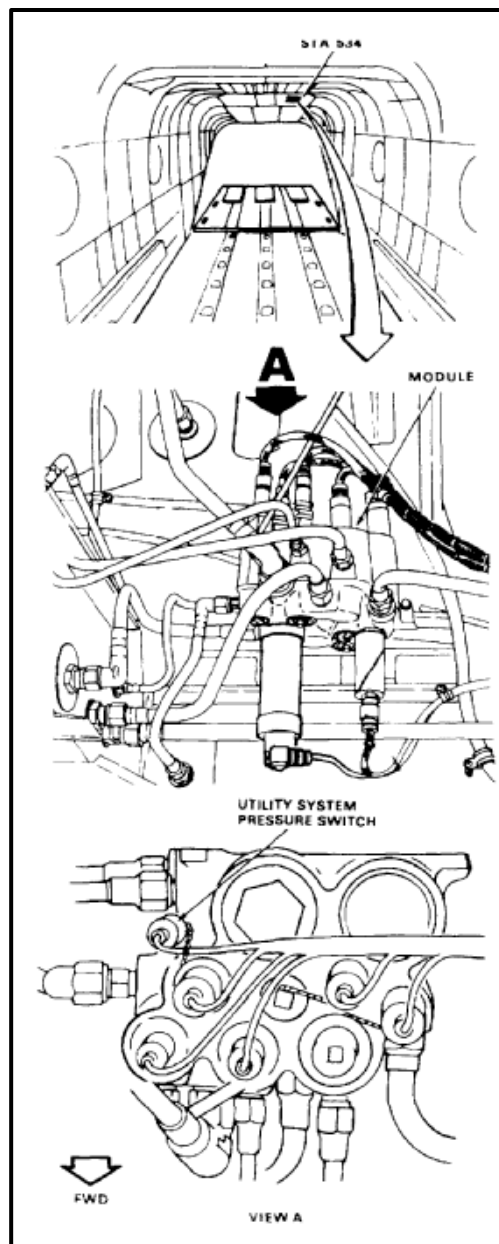

1. Disconnect connector (1) from pressure switch (2).
2. Remove lockwire from pressure switch. Remove switch and packing (3).

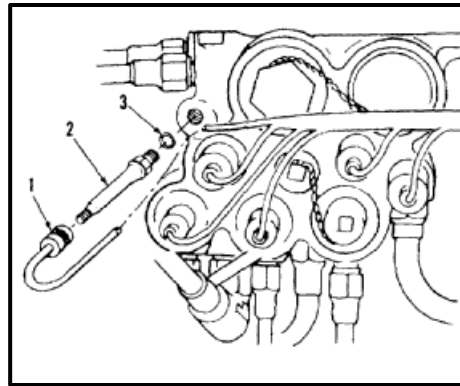
***FOLLOW-ON MAINTENANCE:***

None

END OF TASK

7-704

INITIAL SETUP

Applicable Configurations:

All

Tools:

Aircraft Mechanic's Tool Kit, NSN 51 80-00-323-4692

Materials:

None

Personnel Required:

Medium Helicopter Repairer
Inspector

Equipment Condition:

- Battery Disconnected (Task 1-39)
- Electrical Power Off
- Hydraulic Power Off
- Utility Hydraulic System Depressurized (Task 7-135.1)
- Cargo Ramp Open and Level (TM 55-1520-240-T)

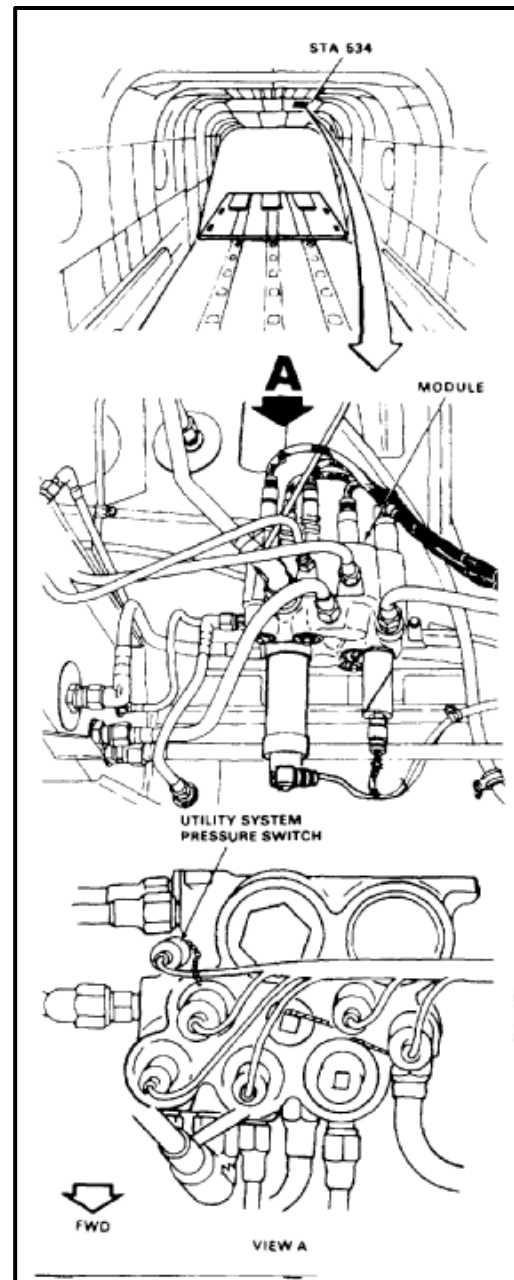

CAUTION

Electrical connectors are to be tightened no more than **1/16 to 1/8 turn** beyond finger-tight during installation, otherwise they will be damaged.

1. Install packing (1) on pressure switch (2). Install switch. Install connector (3).
2. Lockwire pressure switch (2) to pilot solenoid valve (4).

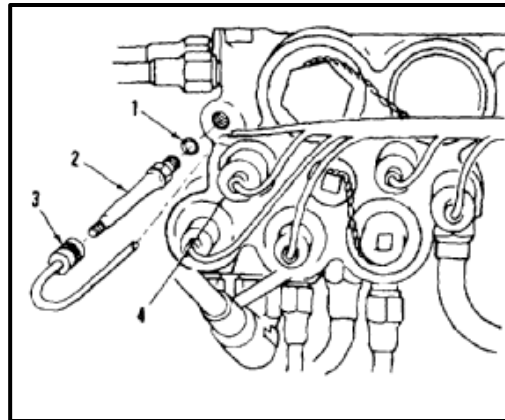
INSPECT**FOLLOW-ON MAINTENANCE:**

None

END OF TASK

7-706

INITIAL SETUP

Applicable Configurations:

All

Tools:

Aircraft Mechanic's Tool Kit, NSN 51 80-00-323-4692
Container, 2 Quart

Materials:

Cloths (E135)
Gloves (E186)

Personnel Required:

Medium Helicopter Repairer

Equipment Condition:

Battery Disconnected (Task 1-39)
Electrical Power Off
Hydraulic Power Off
Utility Hydraulic System Depressurized (Task 7-135.1)
Cargo Ramp Open and Level (TM 55-1520-240-10)

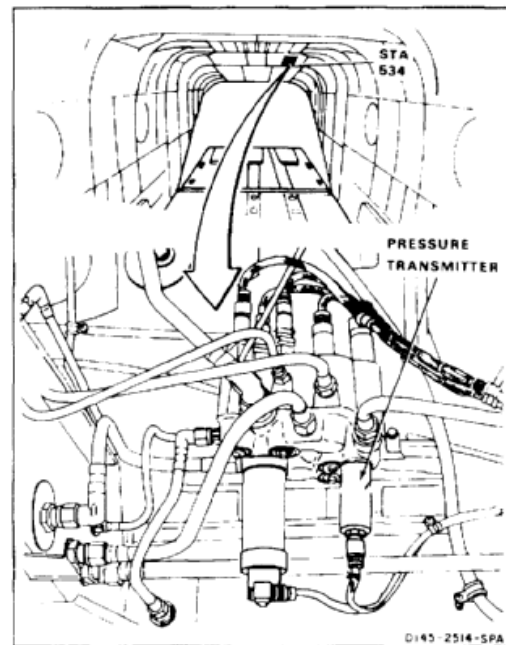
**General Safety Instructions:****WARNING**

Hydraulic fluid (E199) is toxic. It can irritate skin and cause burns. Avoid inhaling. Use only with adequate ventilation. Avoid contact with skin, eyes, or clothing. In case of contact, immediately flush skin or eyes with water for at least **15 minutes**. Get medical attention for eyes.

WARNING

Hydraulic fluid ejected under pressure can cause injury to personnel. Hydraulic fluid sprayed into the air is a fire hazard.

1. Disconnect connector (1) from transmitter (2).
2. Remove transmitter (2) and packing (3) from PRESS XMTR port (4). Use container and cloths (E135) for spilled fluid. Use gloves (E186).

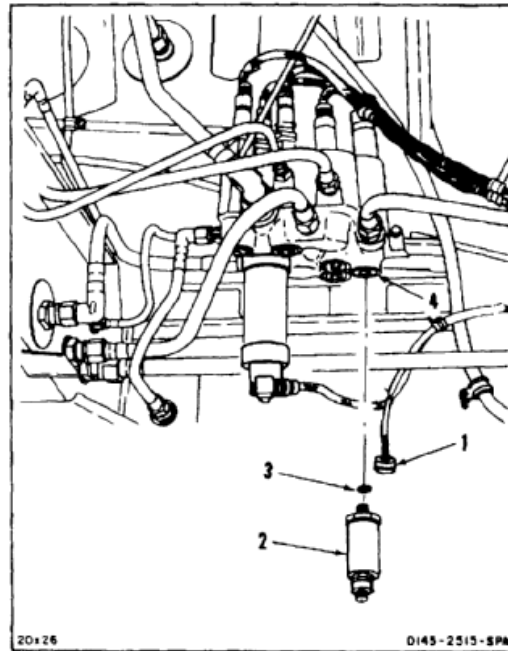
**FOLLOW-ON MAINTENANCE:**

None

END OF TASK

7-708

INITIAL SETUP

Applicable Configurations:

All

Tools:

Aircraft Mechanic's Tool Kit, NSN 51 80-00-323-4692

Materials:Cloths (E135)
Lockwire (E231)**Parts:**

Preformed Packing

Personnel Required:Medium Helicopter Repairer
Inspector**References:**

TM 55-1520-240-23P

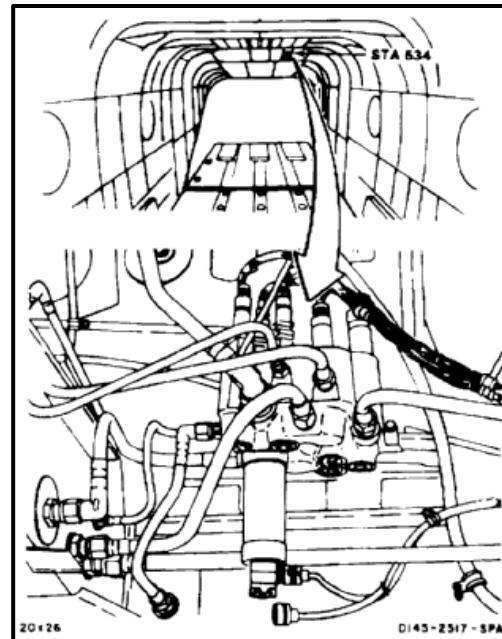

1. Install transmitter (1) and packing (2) in PRESS XMTR port (3).

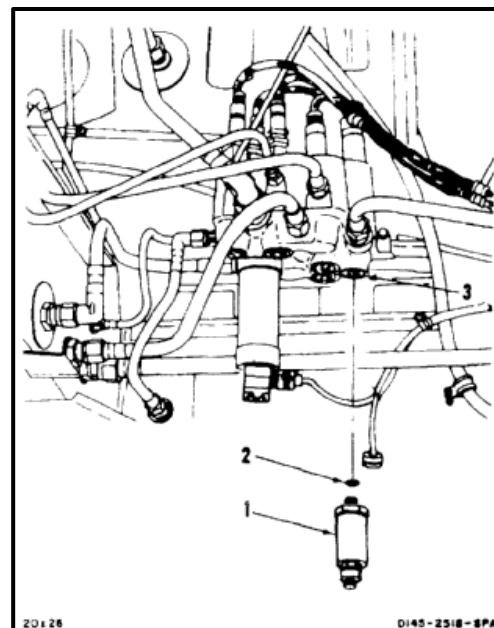

- Lockwire transmitter (1) to module (4). Use lockwire (E231).



Electrical connectors are to be tightened no more than **1/16 to 1/8 turn** beyond finger-tight during installation, otherwise they will be damaged.

- Connect connector (7) to transmitter (1).

INSPECT

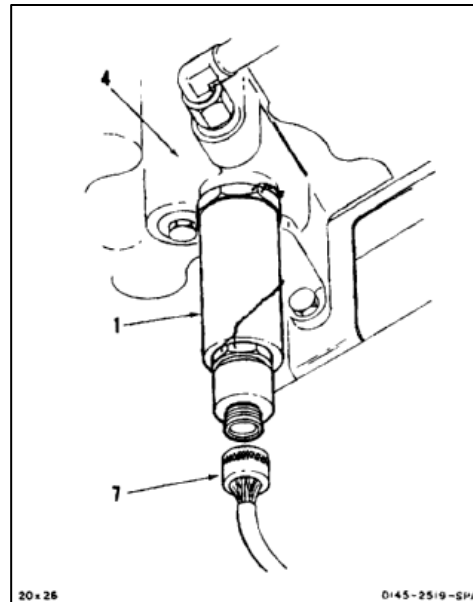

FOLLOW-ON MAINTENANCE:

Perform operational check (TM 55-1520-240-T).
Bleed utility hydraulic reservoir (Task 7-336).

END OF TASK

7-710

7-170 REMOVE PRESSURE CONTROL MODULE PTU VALVE

7-170

INITIAL SETUP**Applicable Configurations:**

All

Tools:

Aircraft Mechanic's Tool Kit, NSN 51 80-00-323-4692
Container, 2 Quart

Materials:

Cloths (E135)
Gloves (E186)

Personnel Required:

Medium Helicopter Repairer

Equipment Condition:

Battery Disconnected (Task 1-39)
Electrical Power Off
Hydraulic Power Off
Utility Hydraulic System Depressurized (Task 7-135.1)
Cargo Ramp Open and Level (TM 55-1520-240-T)

General Safety Instructions:**WARNING**

Hydraulic fluid (E199) is toxic. It can irritate skin and cause burns. Avoid inhaling. Use only with adequate ventilation. Avoid contact with skin, eyes, or clothing. In case of contact, immediately flush skin or eyes with water for at least **15 minutes**. Get medical attention for eyes.

WARNING

Hydraulic fluid ejected under pressure can cause injury to personnel.
Hydraulic fluid sprayed into the air is a fire hazard.

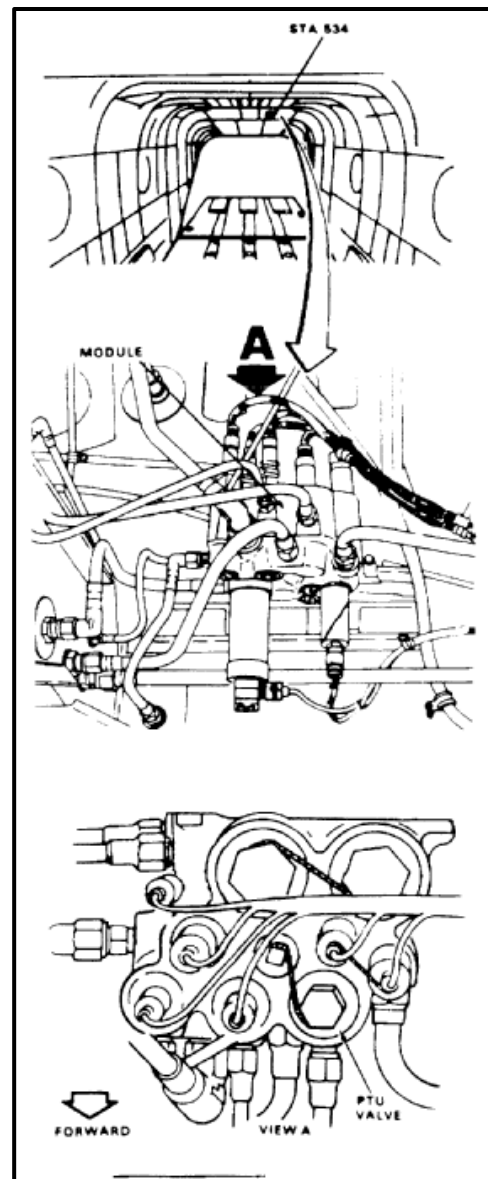

1. Remove lockwire from valve (1).
2. Remove valve (1). Use container and cloths (E135) for spilled fluid. Use gloves (E186).

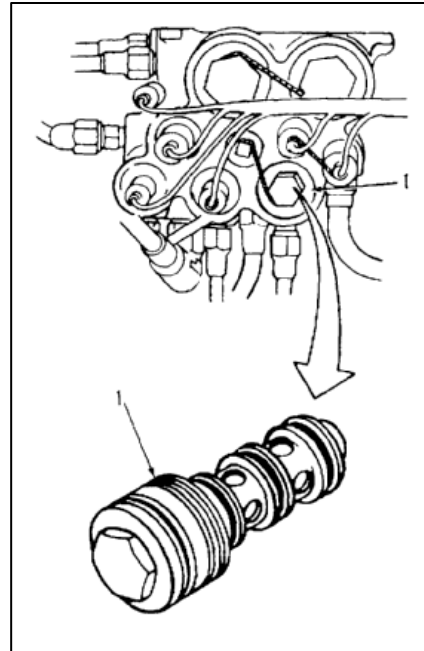

3. Cover valve opening with protective material (E81) or equivalent.

FOLLOW-ON MAINTENANCE:

None

END OF TASK

7-712

INITIAL SETUP

Applicable Configurations:

All

Tools:

Aircraft Mechanic's Tool Kit, NSN 5180-00-323-4692
 Torque Wrench, 100 to 750 Inch-Pounds

Materials:

Lockwire (E231)

Parts:

None

Personnel Required:

Medium Helicopter Repairer
 Inspector

References:

TM 55-1520-240-23P
 Task 7-171.1

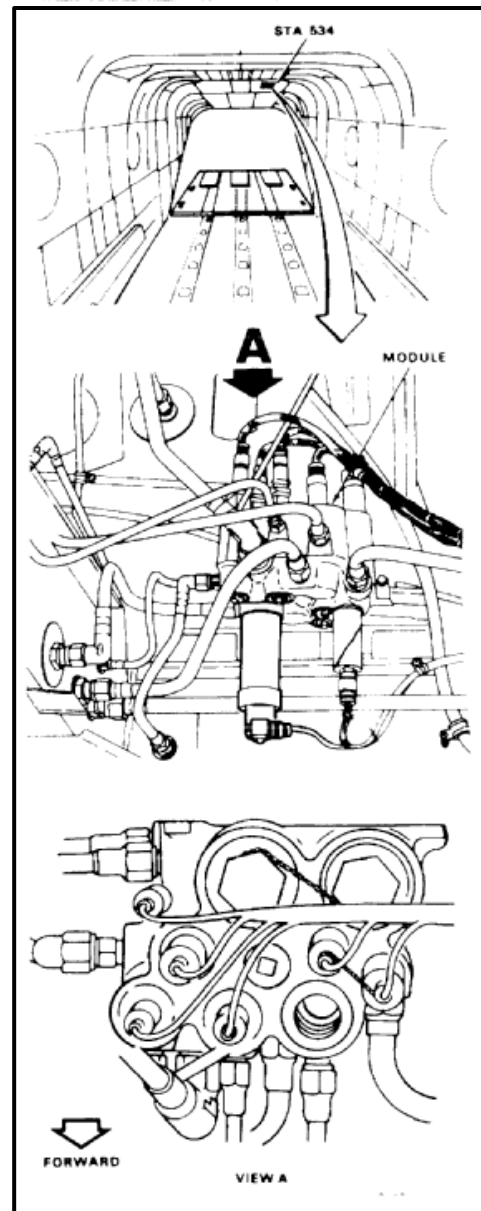

1. Inspect valve (1) for damaged, protruding, or oversize packings and packing retainers (Task 7-42.1).
2. Coat installed seals (2) with hydraulic oil (E199).



Do not force or cock valve during installation. Any sudden resistance or increase in torque may be the result of damaged packings or packing retainers. Remove valve and reinspect (Task 7-42.1).

NOTE

Do not use vise grips or adjustable pliers to install valve.

3. Gently install valve (1) in port (3). Use hand pressure and rotate valve slowly allowing valve to seat itself. Engage thread and hand tighten as far as possible.
4. Torque valve with sufficient force to insure proper seating of valve. Do not exceed **180 inch-pounds**.
5. Lockwire valve (1) to valve (4). Use lockwire (E231).

INSPECT

FOLLOW-ON MAINTENANCE:

Perform functional check (TM 55-1520-240-T).
Bleed utility hydraulic reservoir (Task 7-336).

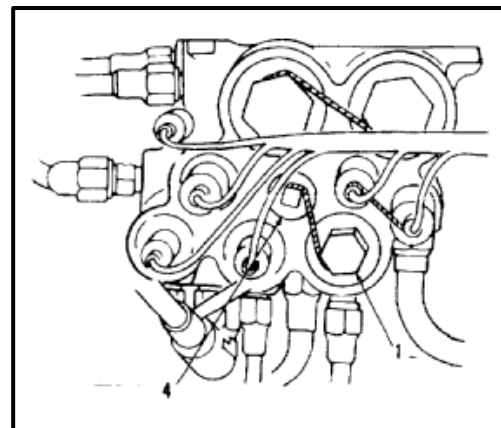
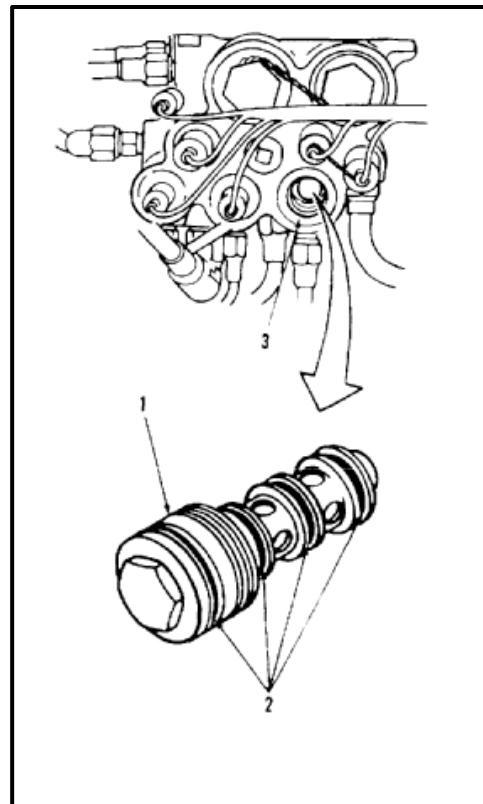

END OF TASK

7-714

7-171.1 INSPECT AND REPAIR PRESSURE CONTROL MODULE PTU VALVE

7-171.1

INITIAL SETUP**Applicable Configurations:**

All

Tools:

As Required

Materials:

None

Parts:Preformed Packings
Packing Retainers**Personnel Required:**Medium Helicopter Repairer
Inspector**Equipment Condition:**

Off Helicopter Task

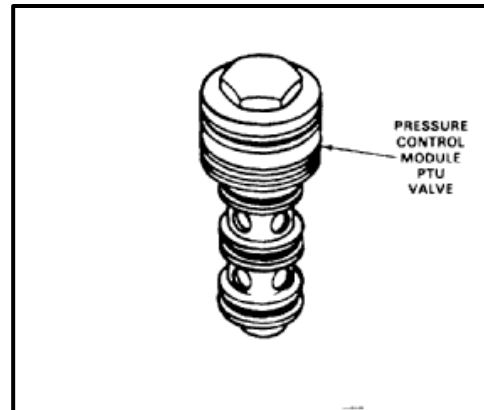

Three-way valve contains three packing/packing retainer sets which appear to be the same size but are not. Ensure valve has correct size packing/packing retainers in each location. Incorrect size packing/packing retainers may cause failure of the flight boost system.

NOTE

Repair of three-way valve consists of replacement of packing and packing retainers only.

1. Inspect valve (1) for damaged, protruding, or incorrect size packings and packing retainers.
2. Replace packings (3, 5, 7, and 9) and/or packing retainers (2, 4, 6, and 8) as required.

PART		INDEX
MS28774-129	Retainer	2
MS28775-129	Packing	3
MS28774-122	Retainer	4
MS28775-122	Packing	5
MS28774-121	Retainer	6
MS28775-121	Packing	7
MS28774-120	Retainer	8
MS28775-120	Packing	9

INSPECT

FOLLOW-ON MAINTENANCE:

None

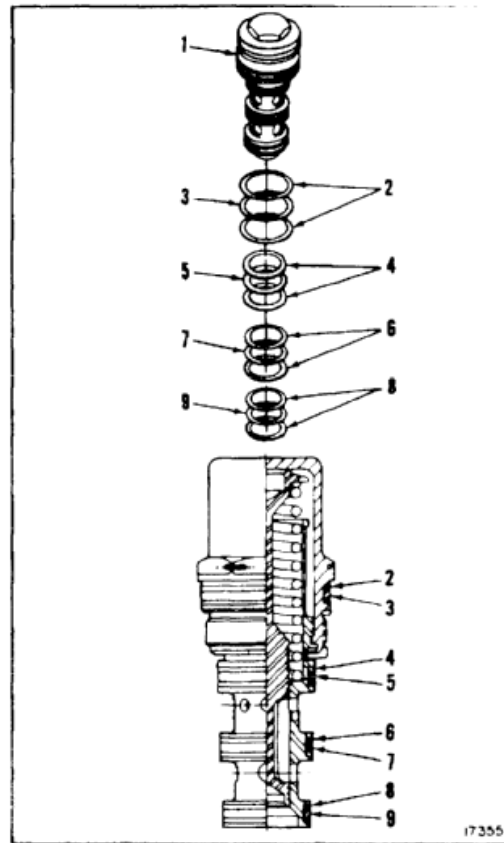

END OF TASK

INITIAL SETUP

Applicable Configurations:

All

Tools:

Aircraft Mechanic's Tool Kit, NSN 51 80-00-323-4692
Container, 2 Quart

Materials:

Cloths (E135)
Gloves (E186)

Personnel Required:

Medium Helicopter Repairer

Equipment Condition:

Battery Disconnected (Task 1-39)
Electrical Power Off
Hydraulic Power Off
Cargo Ramp Open and Level (TM 55-1520-240-10)
Utility Hydraulic System Depressurized (Task 7-135.1)
APU Start Module Accumulator Depressurized (Task 1-65)

General Safety Instructions:**WARNING**

Hydraulic fluid (E199) is toxic. It can irritate skin and cause burns. Avoid inhaling. Use only with adequate ventilation. Avoid contact with skin, eyes, or clothing. In case of contact, immediately flush skin or eyes with water for at least **15 minutes**. Get medical attention for eyes.

WARNING

Hydraulic fluid ejected under pressure can cause injury to personnel. Hydraulic fluid sprayed into the air is a fire hazard.

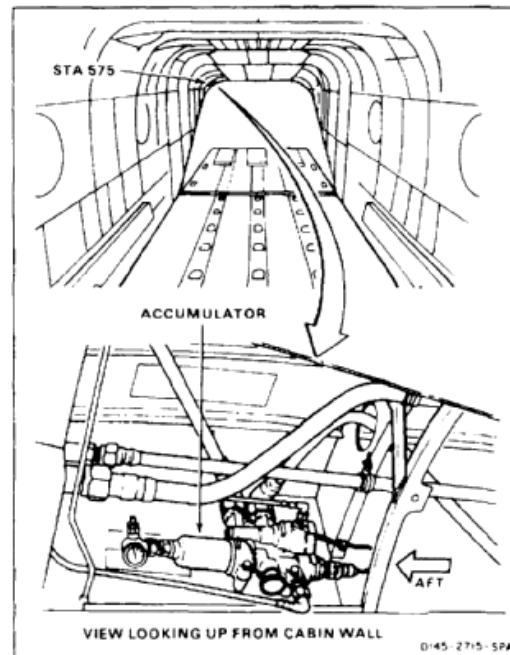

1. Remove lockwire from accumulator (1) and valve and gage (2). Loosen nut (3).
2. Completely loosen nut (3). Remove valve and gage (2) and two packings (4) from accumulator (1). Use gloves (E186).

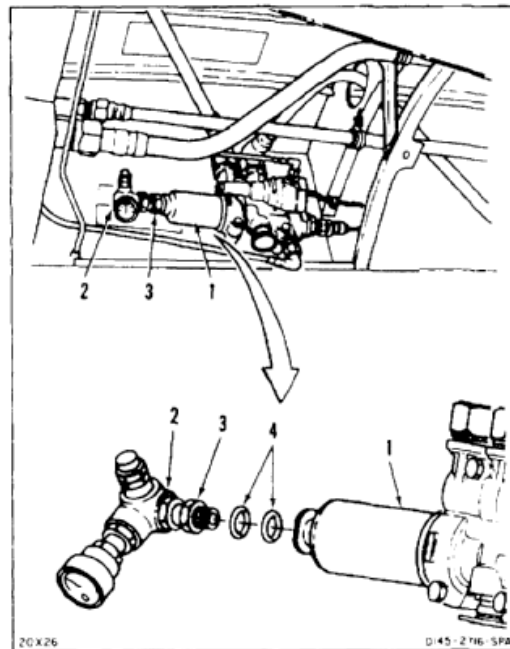

CAUTION

Hold valve and gage to protect it when removing accumulator. Otherwise, damage can occur.

3. Remove accumulator (1), packing (5), and two retainers (6) from module (7). Use container and cloths (E135) for spilled fluid. Use gloves (E186).

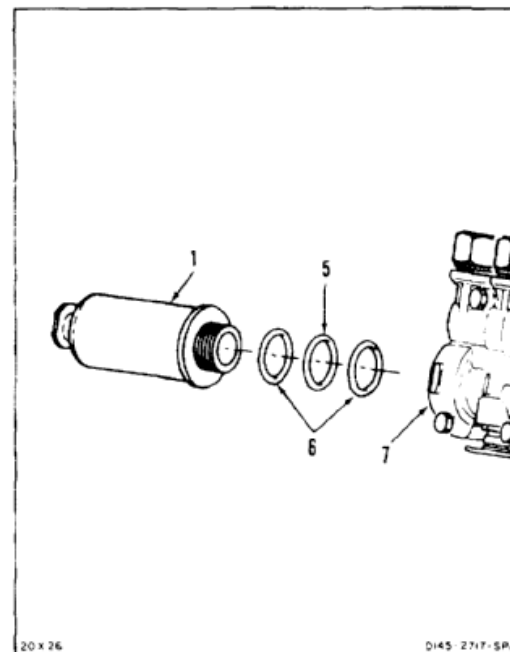

FOLLOW-ON MAINTENANCE:

None

END OF TASK

7-718

INITIAL SETUP

Applicable Configurations:

All

Tools:

Hydraulic Repairer's Tool Kit, NSN 5180-00-323-4891
 Aluminum Rod, 3/8 Inch X 9 Inches
 Retaining Ring Pliers
 Soft Jawed Vise
 Heater Gun
 Technical Inspection Tool Kit, NSN 5180-00-323-5114
 Outside Micrometer Caliper, 1 to 2 Inch
 Telescoping Gage Set

Materials:

None

Personnel Required:

Aircraft Pneudraulics Repairer
 Inspector

References:

Task 7-1.1

Equipment Condition:

Off Helicopter Task

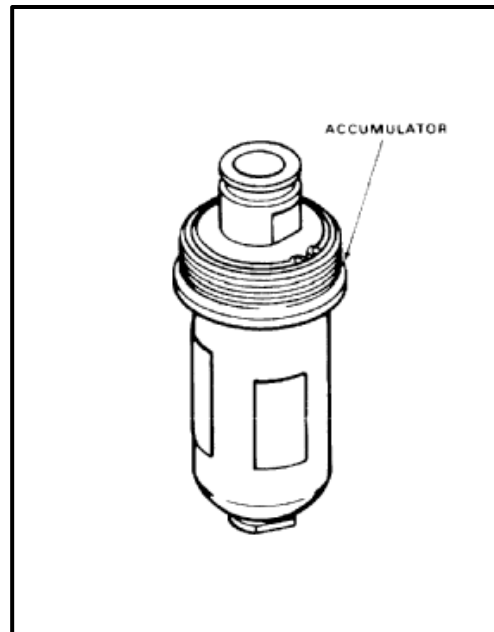
**NOTE**

General inspection criteria (Task 7-1.1) for obvious damage applies unless otherwise stated.

Inspection steps cover parts that are subject to wear.

1. Install housing (1) in vise (2).
2. Remove ring (3) from housing (1). Use retaining ring pliers.
3. Remove retainer (4) from housing (1). Turn counterclockwise.
4. Remove two rings (5) and packing (6) from retainer (4).
5. Remove two threadlocks (7) from retainer (4).
- 5.1. Inspect lands (7.1 and 7.2) at each end of retainer. There shall be no nicks or burrs.
6. Remove housing (1) from vise (2).

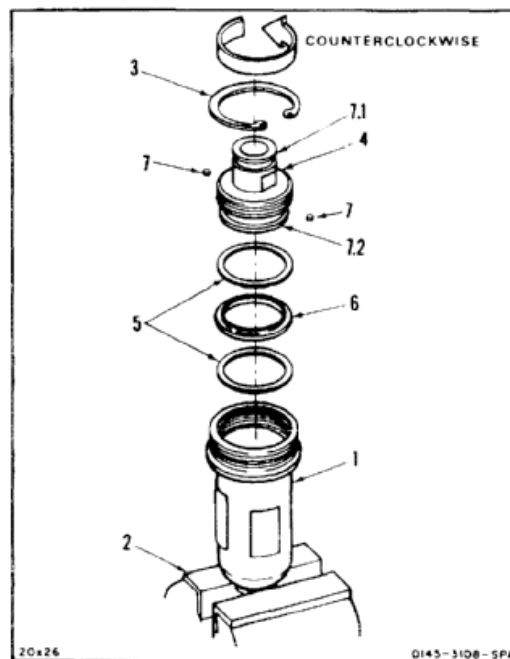

7. Push piston (8) out of housing (1). Use rod (9).
- 7.1. Measure inside diameter (9.1) of housing (1). On accumulator HP1323100-1 (145HS656-1), diameter shall not be more than **1.555 inches**. On accumulator HP1323100-2 (114HS656-2), diameter shall not be more than **1.994 inches**.
8. If two plates (10) are damaged, remove plates. Use heater gun. Record data on plate for transfer.

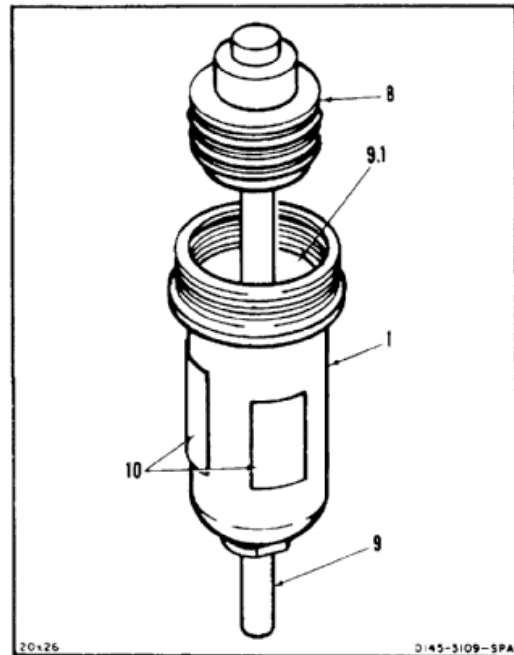

9. Remove four rings (11) and two packings (12) from piston (8).
10. Measure diameter of three lands (13) of piston (8). On accumulator HP1323100-1 (145HS656-1), diameter shall not be less than **1.550 inches**. On accumulator HP1323100-2 (145HS656-2), diameter shall not be less than **1.988 inches**.

FOLLOW-ON MAINTENANCE:

None

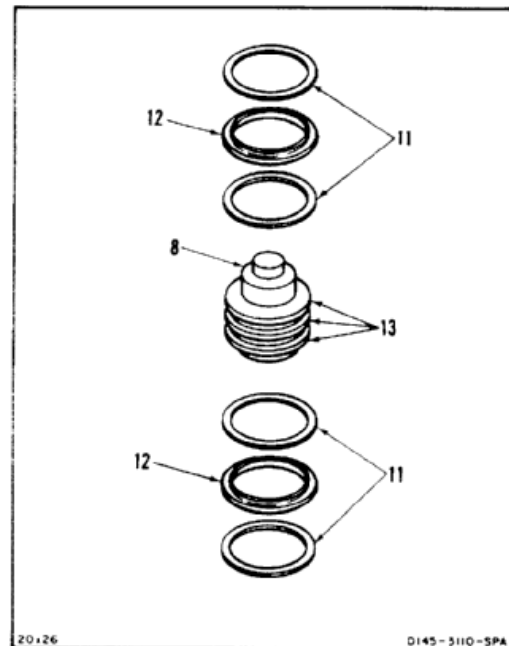

END OF TASK

7-720

7-173.1 DISASSEMBLE AND INSPECT ACCUMULATOR (AD-B1301D390) (AVIM)

7-173.1

INITIAL SETUP**Applicable Configurations:**

All

Tools:

Hydraulic Repairer's Tool Kit, NSN 5180-00-323-4891
 Wrench, 3/4 Inch, Open End
 Wood Dowel, 3/8 Inch X 6 Inches
 Soft Jawed Vise
 Technical Inspection Tool Kit, NSN 5180-00-323-5114

Materials:

None

Personnel Required:

Machinist
 Aircraft Pneudraulics Repairer
 Inspector

References:

Task 7-1.1

Equipment Condition:

Off Helicopter Task

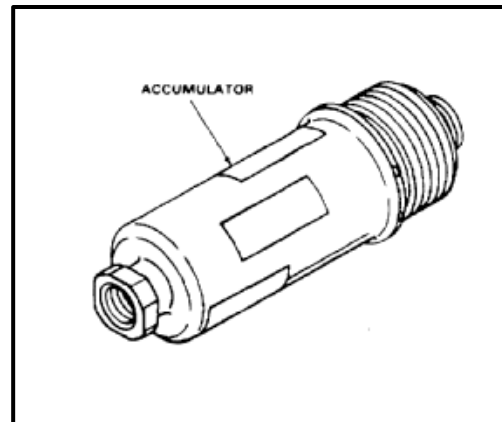
**WARNING**

Release gas and fluid pressures before diaassambling, storing or shipping accumulator. Maximum operating pressure: **3350 psi**.

NOTE

General inspection criteria (Task 7-1.1) for obvious damage applies unless otherwise stated.

Inspection steps cover parts that are subject to wear.

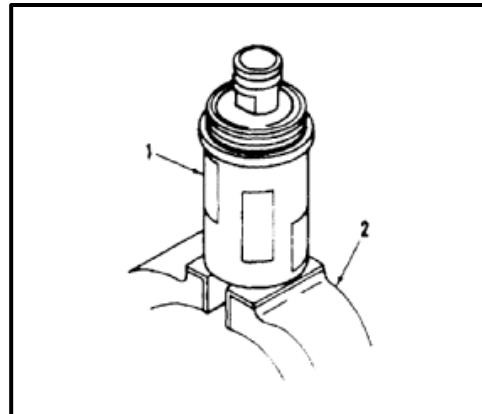

1. Install gas port end of accumulator (1) in vise (2).

2. Remove spiral retaining ring (3) from housing (4).
3. Remove retainer (5) from housing (4).

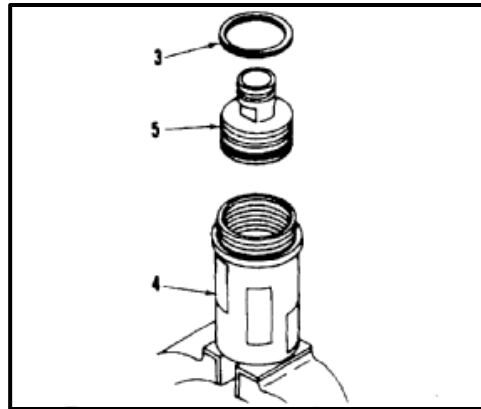

4. Remove packings (6 and 8) and retainer rings (7 and 9) from retainer (5).

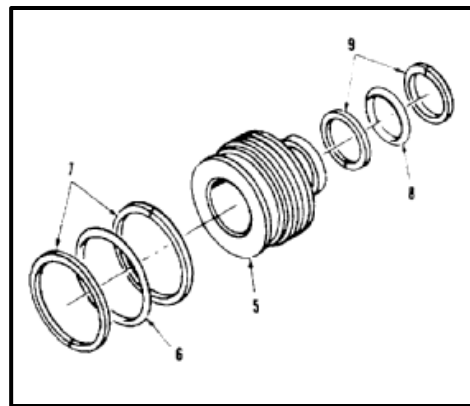

5. Remove housing (4) from vise (2).

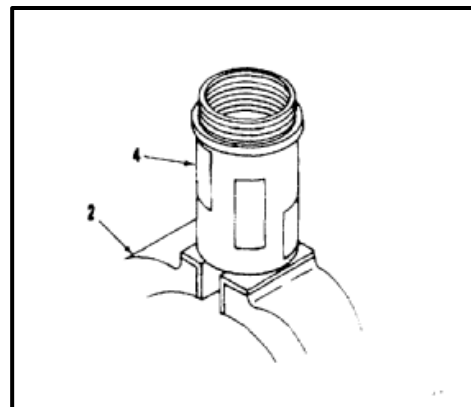



Use care to avoid damage to piston (11) when removing from housing (4).

6. Remove piston (11) from housing (4). Use dowel (10) placed through gas port end of housing (4).

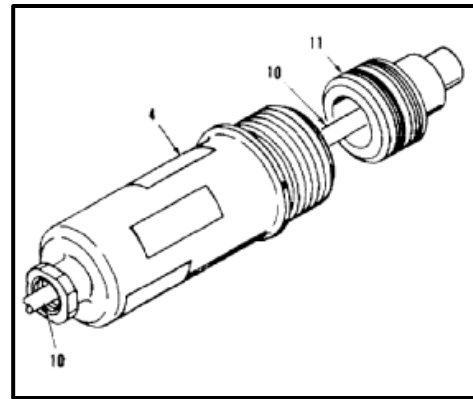

7. Remove packing (12) and retainer rings (13) from piston (11).
8. Measure outside diameter of piston (11) at three lands (14). Diameter shall not be less than **1.486 inches**.
9. Measure inside diameter of housing (4). Diameter shall not be more than **1.493 inches**.
10. Inspect all parts for wear and damage (cracks, nicks, burrs, etc.). Carefully inspect inside wall of housing for scoring. Replace parts as required.

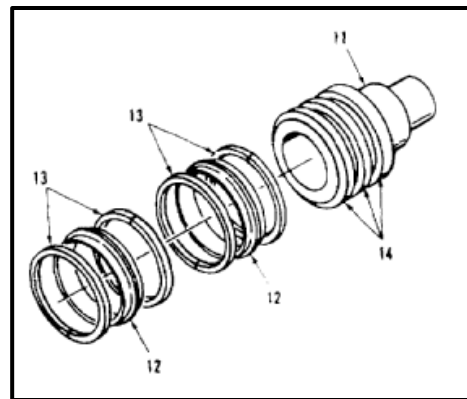

FOLLOW-ON MAINTENANCE:

None

END OF TASK

INITIAL SETUP

Applicable Configurations:

All

Tools:

Hydraulic Repairer's Tool Kit, NSN 5180-00-323-4891
 Wood Dowel, 3/8 Inch X 9 Inches
 Soft Jawed Vise
 Technical Inspection Tool Kit, NSN 5180-00-323-5114
 Outside Micrometer Caliper, 1 to 2 Inch
 Telescoping Gage Set
 Drift Pin, 1/16 Inch

Materials:

None

Personnel Required:

Aircraft Pnedraulics Repairer
 Inspector

References:

Task 7-1.1

Equipment Condition:

Off Helicopter Task

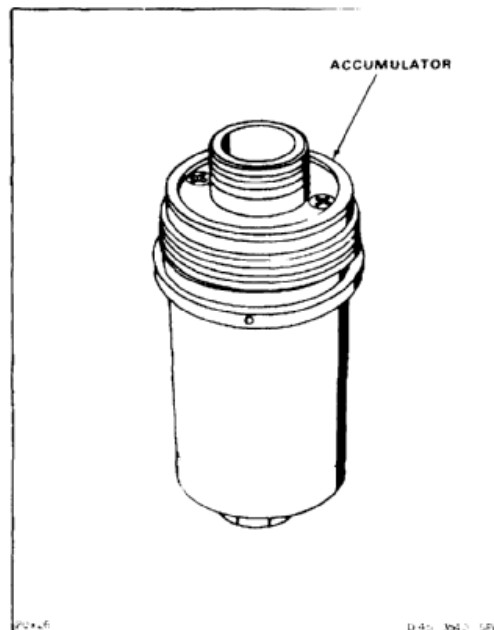
**NOTE**

General inspection criteria (Task 7-1.1) for obvious damage applies unless otherwise stated.

Inspection steps cover parts that are subject to wear.

1. Position housing (1) in vise (2).
2. Remove two screws (3) from plate (4). Remove plate.

WARNING

Wear goggles when removing retainer to prevent injury to eyes.

3. Remove retainer (5). Align one end of retainer and hole (6) in housing (1). Insert **1/16 inch** drift pin (7) through hole (6) and push end of retainer inward. Insert thin bladed screwdriver (8) between retainer and housing. Pry retainer from housing. Use goggles for eyes.
4. Remove housing (1) from vise (2).

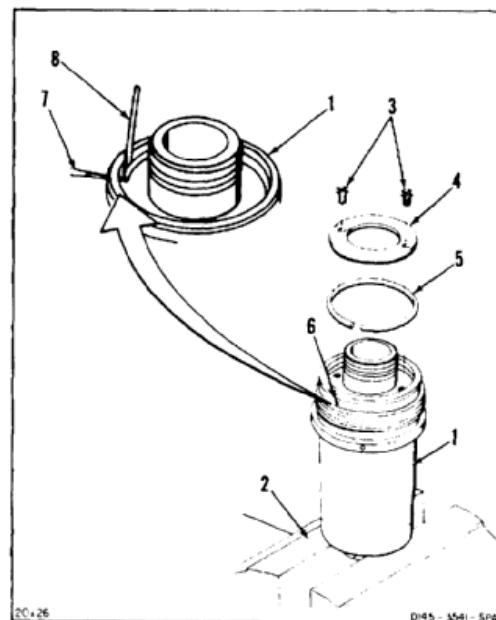

7-174 DISASSEMBLE AND INSPECT ACCUMULATOR (60910) (AVIM) (Continued)

7-174

5. Push cap (9) and separator (10) from housing (1). Use **3/8 inch** rod (11).
6. Remove cap (9) from separator (10).
7. Remove rod (11) from housing (1).
8. Measure inside diameter of housing (1). Inside diameter shall not be more than **1.618 inches**.

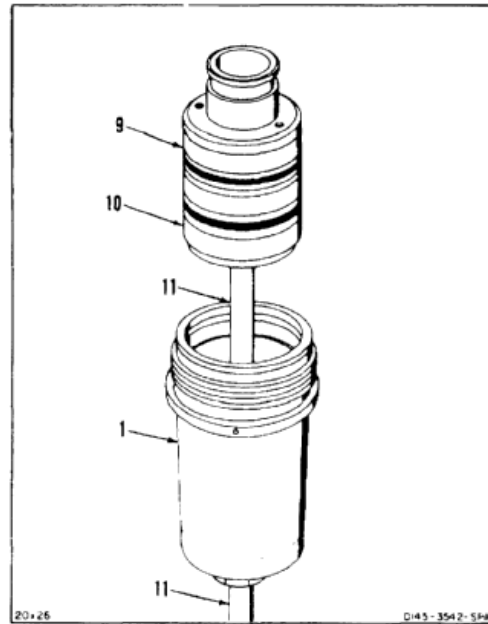

9. Remove two retainers (12) and packing (13) from cap (9).
10. Inspect lands (14 and 15) of cap (9). There shall be no nicks or burrs.
11. Remove two retainers (16) and packing (17) from separator (10).
12. Measure outside diameter of separator (10) at two lands (18). Outside diameter shall not be more than **1.612 inches**.

FOLLOW-ON MAINTENANCE:

None

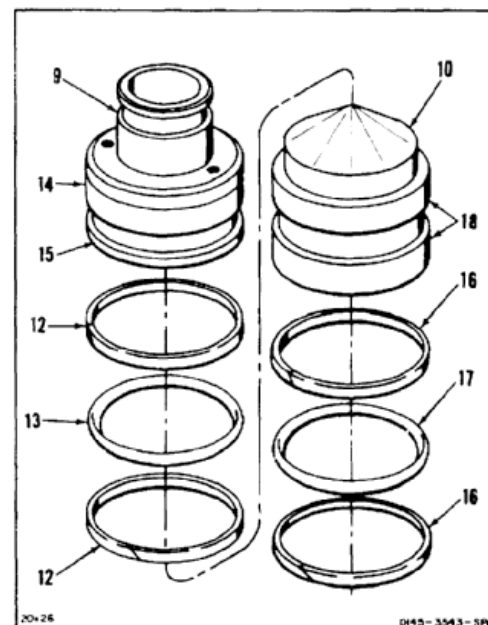

END OF TASK

7-725

INITIAL SETUP

Applicable Configurations:

All

Tools:

- Hydraulic Repairer's Tool Kit, NSN 5180-00-323-4891
- Aluminum Rod, 3/8 Inch X 9 Inches
- Retaining Ring Pliers
- Soft Jawed Vise
- Wrench, Open End, 15/16 Inch

Materials:

- Cloth (E120)
- Adhesive (E43)
- Methyl-Ethyl-Ketone (E244)
- Gloves (E186)

Parts:

- Rings
- Preformed Packings
- Threadlocks

Personnel Required:

- Aircraft Pneudraulics Repairer
- Inspector

References:

TM 55-1520-240-23P

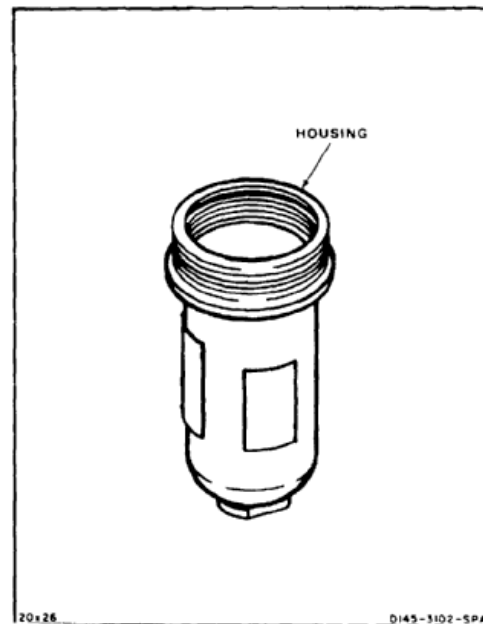

1. Install two packings (1) and four rings (2) on piston (3).

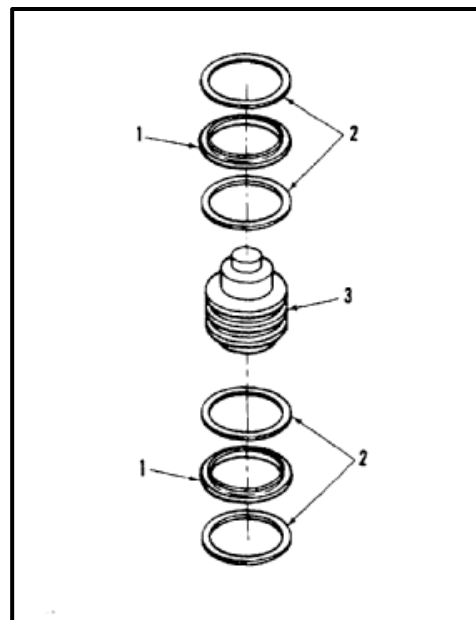

2. Install piston (3) in housing (4), large end first. Push to bottom of housing. Use rod (5).

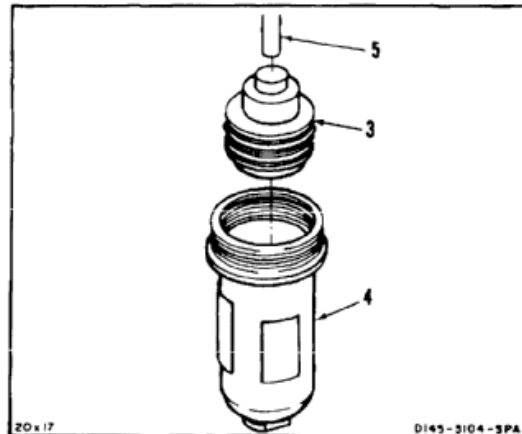

3. Install housing (4) in vise (6).
4. Install two threadlocks (7) in retainer (8). Threadlocks shall be trimmed flush with large diameter of thread in retainer.
5. Install packing (9) and two rings (10) on retainer (8).
6. Install retainer (8) in housing (4). Turn clockwise until entire groove (11) can be seen.
7. Install ring (12) in groove (11).
8. Remove housing (4) from vise (6).
9. If plates (13) are being replaced, transfer data to plates. Install plates as follows:

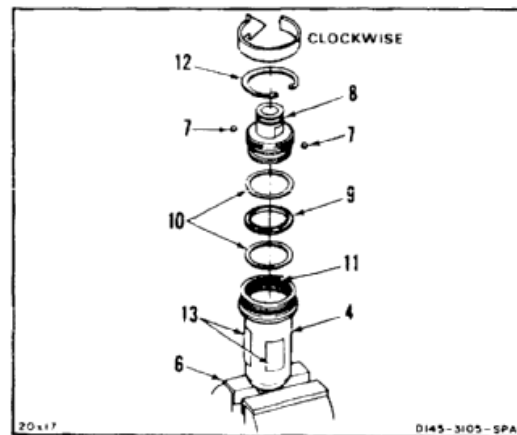

WARNING

Methyl-ethyl-ketone (E244) is flammable and toxic. It can irritate skin and cause burns. Use only in well-ventilated area, away from heat and open flame. In case of contact, immediately flush skin or eyes with water for at least **15 minutes**. Get medical attention.

- a. Clean housing (4) and plates (13) with methyl-ethyl-ketone (E244). Use cloth (E120) and gloves (E186).
- b. Apply adhesive (E43) to all contact surfaces between plate (13) and housing (4).
- c. Install plate (13) on housing (4).

INSPECT

FOLLOW-ON MAINTENANCE:

Perform functional test (Task 7-177).

END OF TASK

INITIAL SETUP

Applicable Configurations:

All

Tools:

Hydraulic Repairer's Tool Kit, NSN 5180-00-323-4891
Wrench, 3/4 Inch Open End
Torque Wrench, 0 to 100 Foot-Pounds
Source of Low Pressure Compressed Air
Soft Jawed Vise

Materials:

Dry Cleaning Solvent (E162)
Hydraulic Fluid (E199)
Cloth (E120)
Gloves (E186)

Parts:

Packings
Retaining Rings

Personnel Required:

Aircraft Pneudraulics Repairer (2)
Inspector

References:

TM 55-1520-240-23P

WARNING

Dry cleaning solvent (E162) is flammable and toxic. It can irritate skin and cause burns. Use only in well-ventilated area, away from heat and open flame. In case of contact, immediately flush skin or eyes with water for at least **15 minutes**. Get medical attention for eyes.

1. Clean all parts (1 thru 3) with dry cleaning solvent (E162). Dry with low pressure compressed air. Use goggles for eyes. Use gloves (E186).

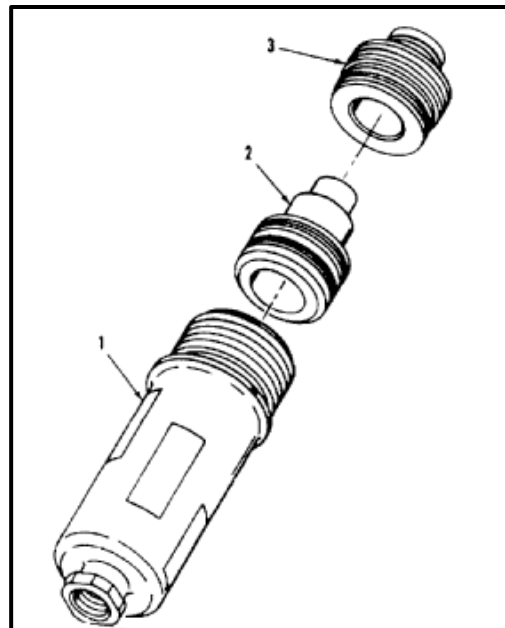

2. Lightly coat packing (4) and retainer rings (5) with hydraulic fluid (E199). Use cloth (E120).



Ensure retainer rings (5) for packing (4) are installed with radius of retainer rings (5) in corner of packing (4).

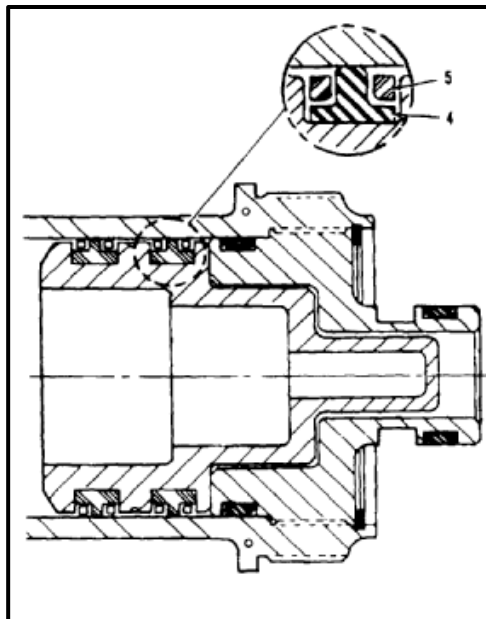

3. Install packings (4) and retainer rings (5) in grooves of piston (2).

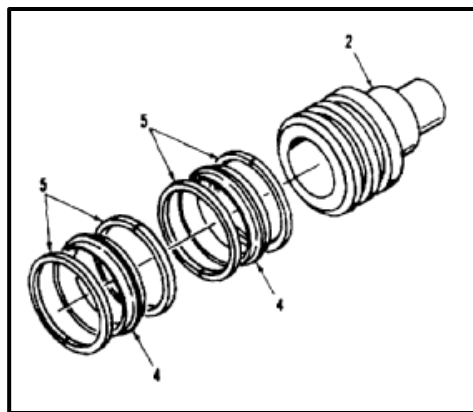

4. Lightly coat packing (6) and retainer rings (7) with hydraulic fluid (E199).
5. Install packing (6) and retainer rings (7) in groove of retainer (3).

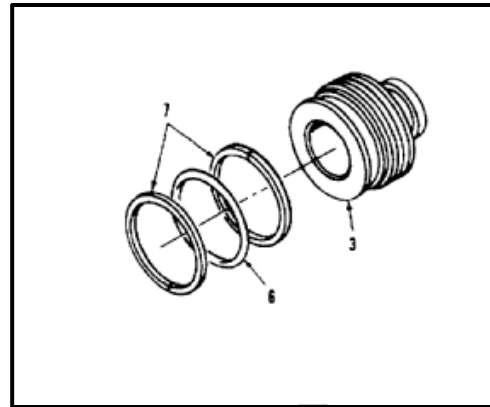

6. Apply light coat of hydraulic fluid (E199) to inside wall of housing (1) and OD of piston (2) in area of packing (4). Use cloth (E120).

NOTE

The **two inches** will allow enough space to insert retainer (3).

7. Install large end of piston (2) into housing (1) for a distance of approximately **two inches**.

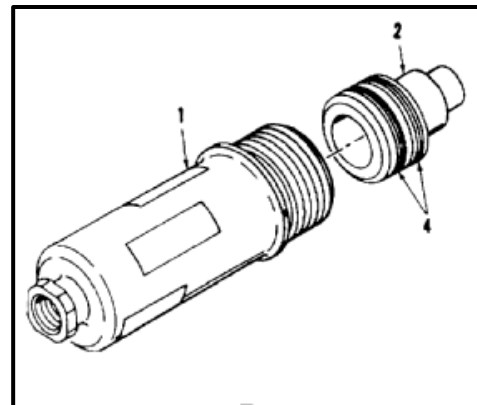

8. Place gas port end of housing (1) in vise (10).
9. Apply light coat of hydraulic fluid (E199) in retainer area of packing (6). Use cloth (E120).
10. Thread retainer (3) into housing (1) and torque to **20 to 30 foot-pounds**.

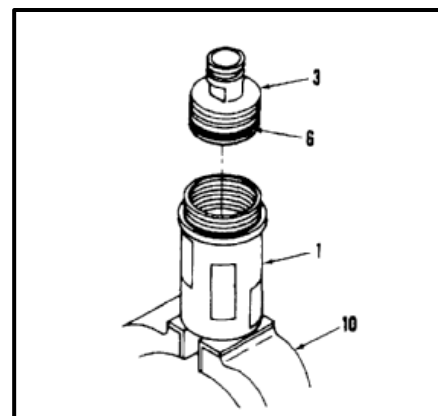

7-175.1 ASSEMBLE ACCUMULATOR (AD-B130-1D390) (AVIM) (Continued)**7-175.1**

11. Install spiral retaining ring (11) into retaining ring groove of housing (1).
12. Lightly lubricate with hydraulic fluid (E199) and install packing (12) and retainer rings (13) on port end of retainer (3).
13. Remove accumulator (1) from vise (10).

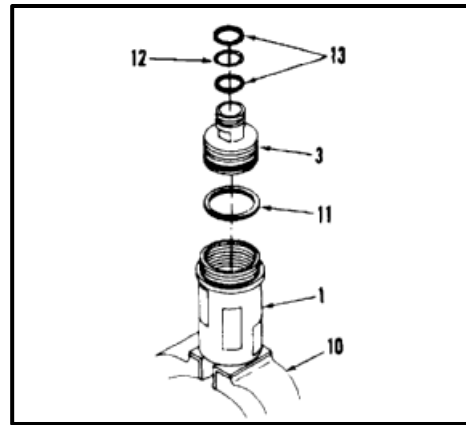
INSPECT**FOLLOW-ON MAINTENANCE:**

Test accumulator (Task 7-50).

END OF TASK

INITIAL SETUP

Applicable Configurations:

All

Tools:

Hydraulic Repairer's Tool Kit, NSN 5180-00-323-4891
Soft Jawed Vise

Materials:

None

Parts:

Retainers
Preformed Packings
Screws

Personnel Required:

Aircraft Pneudraulics Repairer
Inspector

References:

TM 55-1520-240-23P

1. Install packing (1) and two retainers (2) on separator (3). Position slots in retainers **180°** apart.
2. Install two retainers (4) and packing (5) on cap (6).

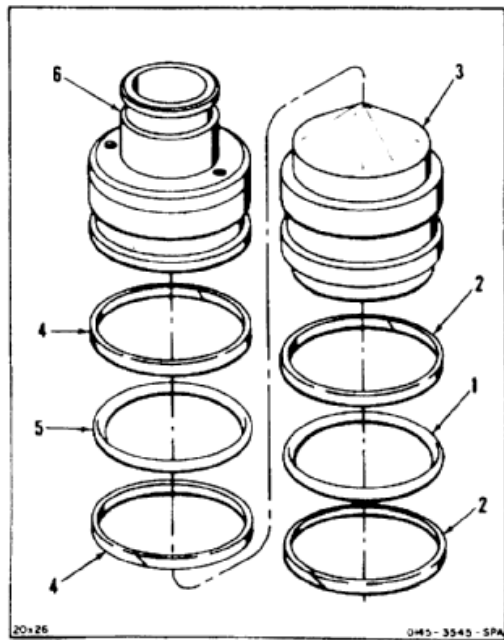
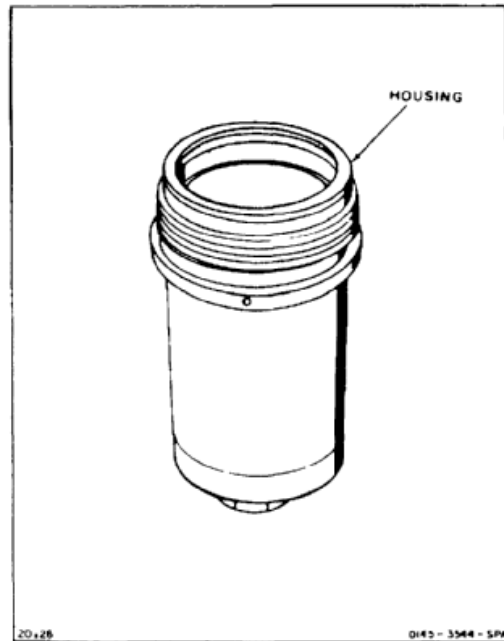

3. Install separator (3) in housing (7), coned end (8) outward. Push separator to bottom of housing.
4. Install cap (6) in housing (7), large end first. Push cap until bottomed.

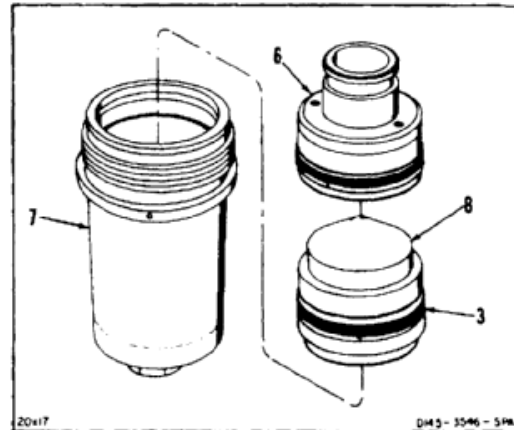

5. Install housing (7) in vise (9).

WARNING

Wear goggles when removing retainer to prevent injury to eyes.

6. Install retainer (10) in groove (11) of housing (7). Wear goggles for eyes.
7. Position plate (12) in housing (7). Install two new screws (13). Screws are self-locking. If screws turn freely, replace screws.
8. Remove housing (7) from vise (9).

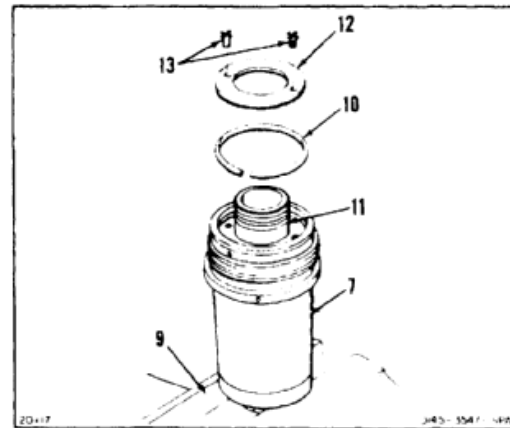

INSPECT

FOLLOW-ON MAINTENANCE:

Perform functional test (Task 7-177).

END OF TASK

INITIAL SETUP

Applicable Configurations:

All

Tools:

- Hydraulic Repairer's Tool Kit, NSN 5180-00-323-4891
- Reservoir (APP E-11)
- Test Block (1323TF100 Hydra Power)
- Hydraulic Test Stand
- Nitrogen Supply
- Soft Jawed Vise
- Wood Dowel, 1/2 Inch X 9 Inches
- Container, 2 Quart
- Graduate, 5 cc and 100 cc (2)
- Pressure Gage, 10 psi
- Pressure Gage, 2000 psi
- Pressure Gage, 5000 psi
- Restrictor Valve (2)
- Shutoff Valve (4)
- Nipple, 1/4 Inch (2)
- Tube, 1/4 Inch, 0 to 5000 psi
- Tee, 1/4 Inch (5)
- Stop Watch

Materials:

- Cloths (E120)
- Hydraulic Fluid (E199)
- Gloves (E186)

Parts:

- Packing
- Retainers

Personnel Required:

- Aircraft Pneudraulics Repairer
- Inspector

References:

Appendix E

Equipment Condition:

- Off Helicopter Task
- Accumulator Installed In Crash Proof Box
- Test Setup

General Safety Instructions:

WARNING

Use suitable crash box to shield personnel and equipment in case of failure during test.

WARNING

Hydraulic fluid (E199) is toxic. It can irritate skin and cause burns. Avoid inhaling. Use only with adequate ventilation. Avoid contact with skin, eyes, or clothing. In case of contact, immediately flush skin or eyes with water for at least **15 minutes**. Get medical attention for eyes.

WARNING

Hydraulic fluid ejected under pressure can cause injury to personnel. Hydraulic fluid sprayed into the air is a fire hazard.

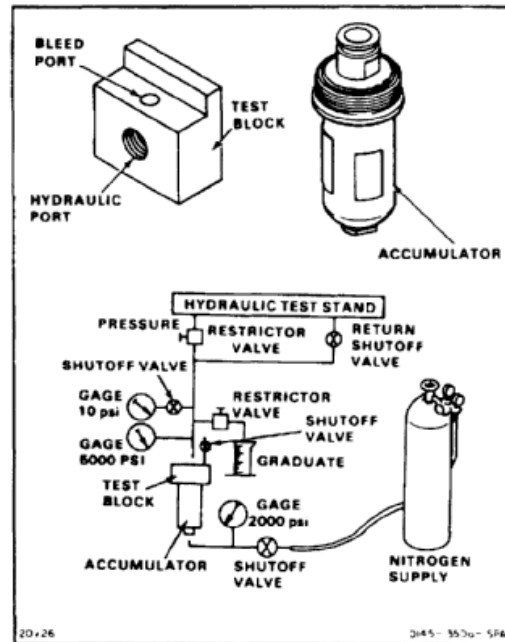

**7-177 TEST ACCUMULATORS (60910, HP1323100, OR AD-B130-7-177 1D390)
(AVIM) (Continued)**

7-177

NOTE

There are three accumulators 60910, HP1323100 and AD-B130-1D390. Procedure is same to test each accumulator. Accumulator HP1323100 is shown here.

INTEGRITY PRESSURE TEST

1. Insert wood dowel (1) through gas port (2), to contact piston of accumulator (3). Push dowel until piston bottoms. Remove dowel.
2. Insert wood dowel (1) through fluid port (4) to contact piston. Push dowel to move piston about **2 inches**. Remove dowel.
3. Position accumulator (3) with port (2) up. Fill accumulator with fluid (E199) through port (2). Use gloves (E186).
4. Install plug (5) in port (2).

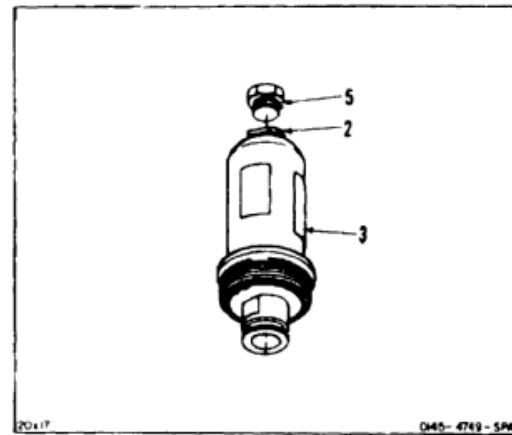
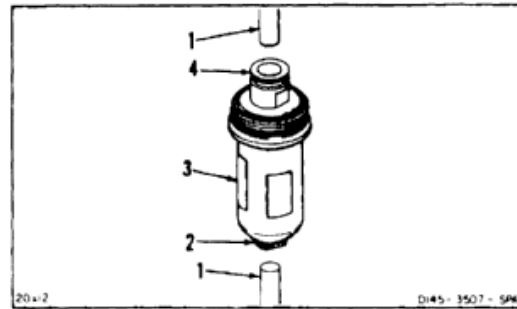

5. Position accumulator (3) with port (4) up. Fill accumulator (3) through port (4) with fluid (E199).
6. Install two retainers (6) and packing (7) in groove of retainer (4).
7. Install accumulator (3) in test block (8).

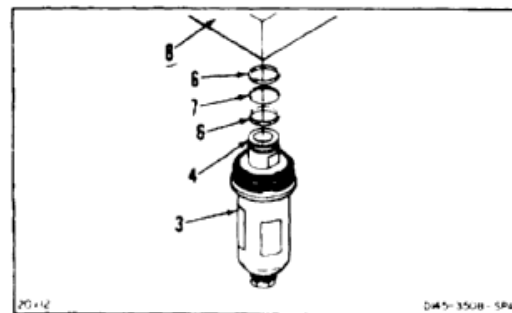

8. Connect fluid port (9) of test block (8) to test setup (10) as shown.
9. Connect valve (11) to bleed port (12) of test block (8).
10. Close valves (11, 13, 14, and 15).
11. Apply **4500 psi** pressure to port (9). Adjust valve (16) for **4500 psi** on gage (17). Maintain pressure for **2 minutes**.
12. Check accumulator (3) for leakage. There shall be no leakage.
13. Release pressure to **0 psi** on gage (17). Close valve (16). Open valve (15).
14. Close valve (15).
15. Repeat steps 11 thru 14. Then perform step 16.

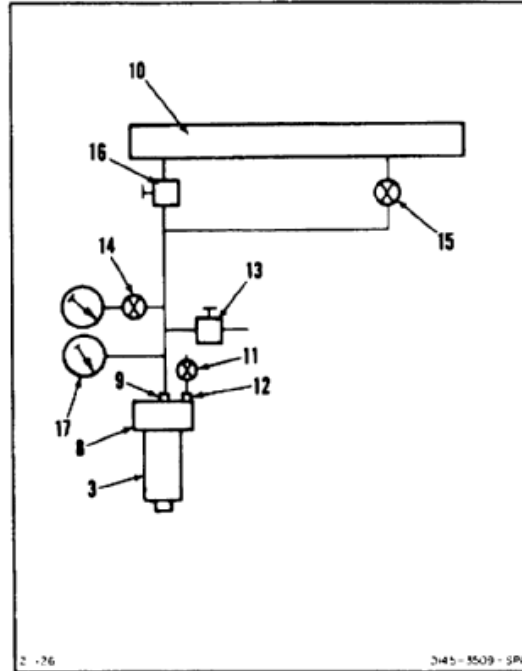

FLUID LEAK TEST

16. Open valve (14). Apply **2 psi** pressure to port (9). Adjust valve (16) for **2 psi** on gage (23). Maintain pressure for **30 minutes**.
17. Check for leakage at port (2). Leakage at port (2) shall be insufficient to form a drop.
18. Release pressure to **0 psi** on gage (23). Close valve (16). Open valve (15).
19. Close valves (14 and 15).
20. Apply **3000 psi** pressure to port (9). Adjust valve (16) for **3000 psi** on gage (17). Maintain pressure for **3 minutes**.
21. Check for leaks at port (2). Leakage at port (2) shall be insufficient to form a drop.
22. Release pressure to **0 psi** on gage (17). Close valve (16). Open valve (15).
23. Disconnect test setup (10) from port (9).

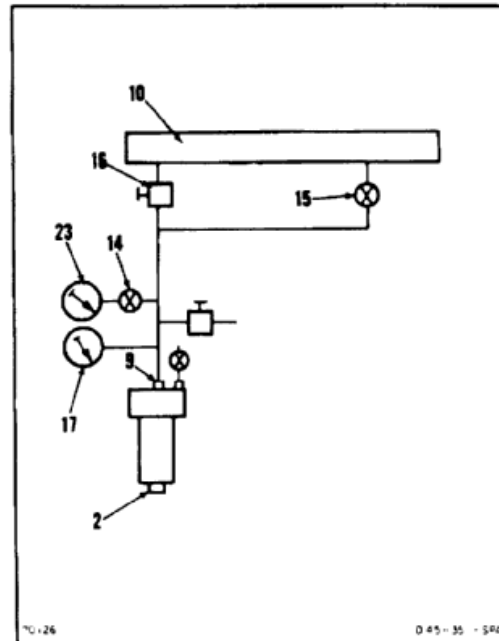

**7-177 TEST ACCUMULATORS (60910, HP1323100, OR AD-B130-7-177 1D390)
(AVIM) (Continued)**

7-177

GAS LEAK TEST

24. Insert wood dowel (1) through port (2) to contact piston of accumulator (3). Push dowel until piston bottoms. Remove dowel.
25. Connect reservoir (24) to port (9).
26. Fill reservoir (24) with fluid (E199) until tube (25) is covered.
27. Bleed air from block (8). Open valve (11). Use cloths (E120) for spilled fluid.
28. Close valve (11).

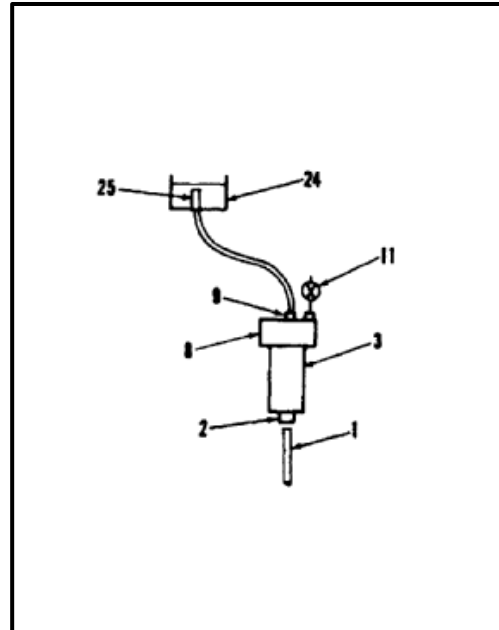

29. Position accumulator (3) on its side.
30. Connect tube (18) to valve (19) and connect valve (19) to port (2).
31. Apply **200 psi** pressure to port (2). Open valve (19) for **200 psi** on gage (17). Close valve (19).
32. Fill graduate (26) with fluid (E199). Place graduate over tube (25) in reservoir (24). Fluid level in graduate must be above fluid level in reservoir. Use **5 cc** graduate.
33. Record fluid level in graduate (26). Check fluid level after **3 minutes**. Fluid level shall not change by more than **0.25 cc**.
34. Open valve (19). Adjust for **2000 psi** on gage (17). Close valve (19).
35. Repeat step (33). Then perform step 36.
36. Release pressure to **0 psi** on gage (17). Open regulator (22).
37. Remove graduate (26) from reservoir (24).
38. Disconnect reservoir (24) from port (9). Use container for spilled fluid.
39. Disconnect valve (11) from port (12).

WARNING

Deplete air pressure before disconnecting tubes or hoses. Otherwise, injury to personnel can occur.

40. Disconnect tube (18) from port (2).

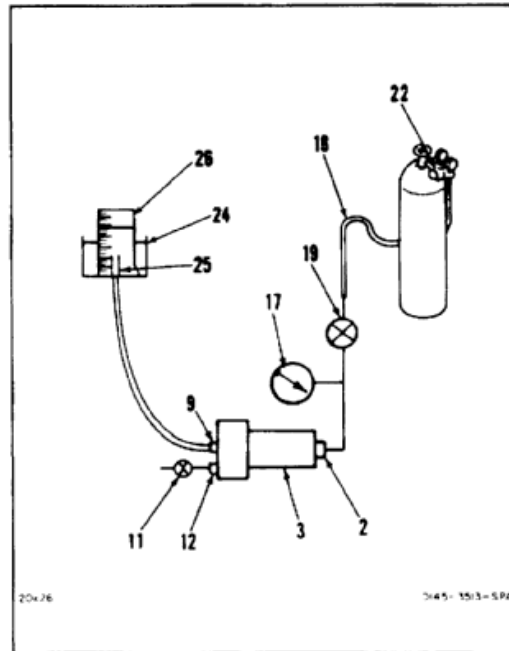

**7-177 TEST ACCUMULATORS (60910, HP1323100, OR AD-B130-7-177 1D390)
(AVIM) (Continued)**

7-177

41. Remove accumulator (3) from block (8).
42. Remove two retainers (6) and packing (7) from accumulator (3).

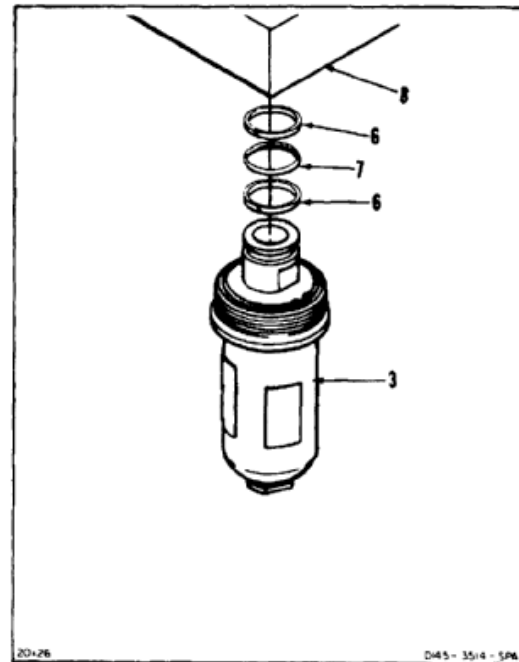
INSPECT**FOLLOW-ON MAINTENANCE:**

None

END OF TASK

INITIAL SETUP

Applicable Configurations:

All

Tools:

Aircraft Mechanic's Tool Kit, NSN 5180-00-323-4692
Torque Wrench, 150 to 750 Inch-Pounds

Materials:

Lockwire (E231)

Parts:

Preformed Packings
Retainers

Personnel Required:

Medium Helicopter Repairer
Inspector

References:

TM 55-1520-240-23P

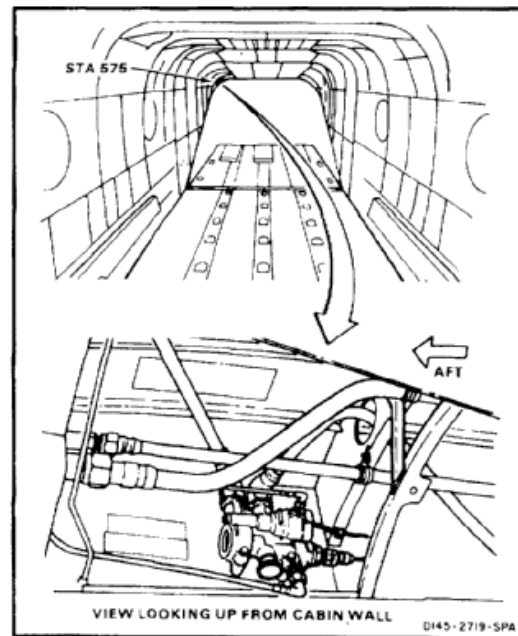

1. Install packing (2) and two retainers (3) on accumulator (1).
2. Install accumulator (1) in ACCUM port (4). Torque accumulator (1) to **250 to 300 inch-pounds**.

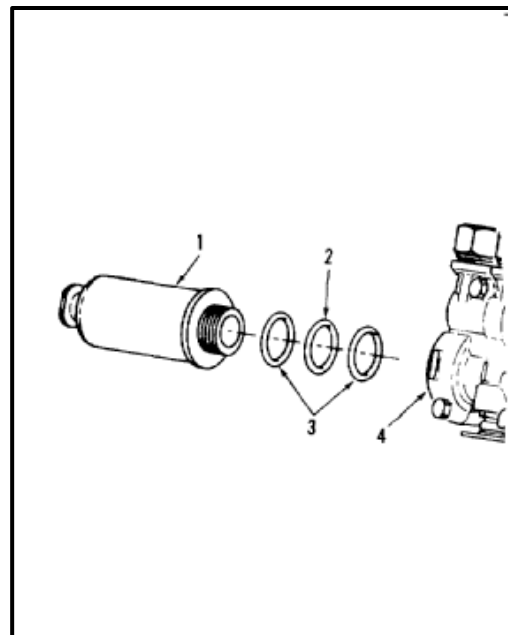

7-178 INSTALL APU START MODULE ACCUMULATOR (Continued)

7-178

3. Install valve and gage (5) and two packings (6) in accumulator (1).
4. Tighten nut (7) against accumulator (1).
5. Lockwire valve and gage (5) and accumulator (1). Use lockwire (E231).

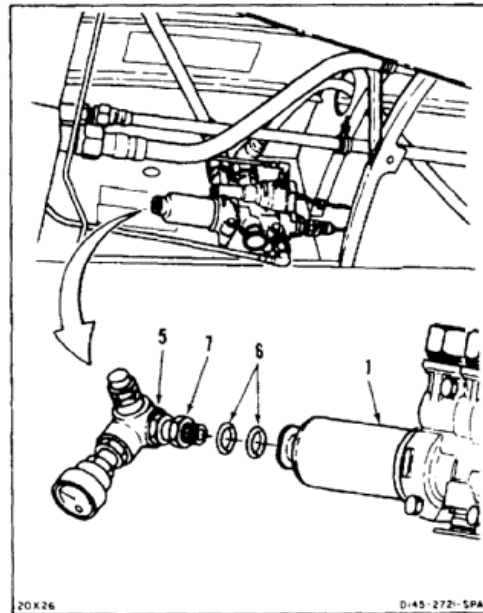
INSPECT**FOLLOW-ON MAINTENANCE:**

- Service APU accumulator (Task 1-65).
- Bleed utility hydraulic system (Task 7-336).
- Perform operational check (TM 55-1520-240-T).
- Close cargo ramp (TM 55-1520-240-T).

END OF TASK

7-741

INITIAL SETUP

Applicable Configurations:

All

Tools:

Aircraft Mechanic's Tool Kit, NSN 5180-00-323-4692
 Container, 2 Quart

Materials:

Cloths (E135)
 Gloves (E186)

Personnel Required:

Medium Helicopter Repairer

Equipment Condition:

Battery Disconnected (Task 1-39)
 Electrical Power Off
 Hydraulic Power Off
 Cargo Ramp Open and Level (TM 55-1520-240-T)
 Utility Hydraulic System Depressurized (Task 7-135.1)

General Safety Instructions:**WARNING**

Hydraulic fluid (E199) is toxic. It can irritate skin and cause burns. Avoid inhaling. Use only with adequate ventilation. Avoid contact with skin, eyes, or clothing. In case of contact, immediately flush skin or eyes with water for at least **15 minutes**. Get medical attention for eyes.

WARNING

Hydraulic fluid ejected under pressure can cause injury to personnel.
 Hydraulic fluid sprayed into the air is a fire hazard.

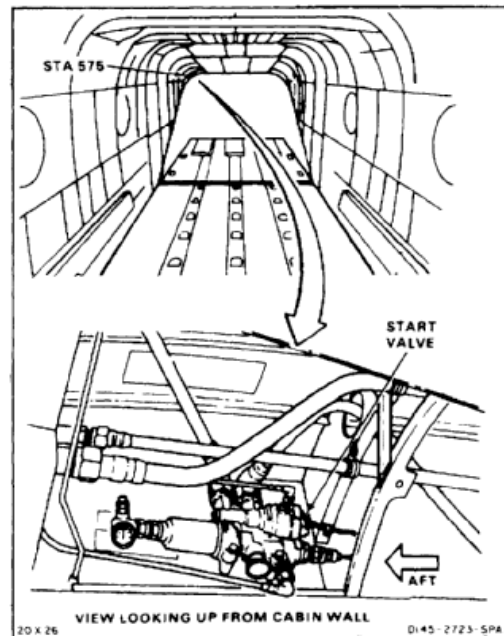

1. Remove lockwire from valve (1). Remove valve, four packings (2), and eight retainers (3) from APU START V port (4). Use container and cloths (E135) for spilled fluid. Use gloves (E186).

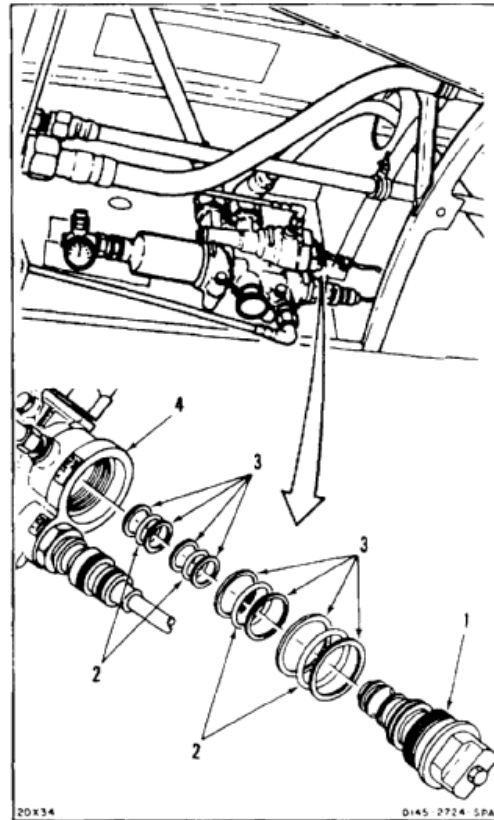
**FOLLOW-ON MAINTENANCE:**

None

END OF TASK

INITIAL SETUP

Applicable Configurations:

All

Tools:

Aircraft Mechanic's Tool Kit, NSN 5180-00-323-4692

Materials:

Lockwire (E231)

Parts:Preformed Packings
Retainers**Personnel Required:**Medium Helicopter Repairer
Inspector**References:**

TM 55-1520-240-23P

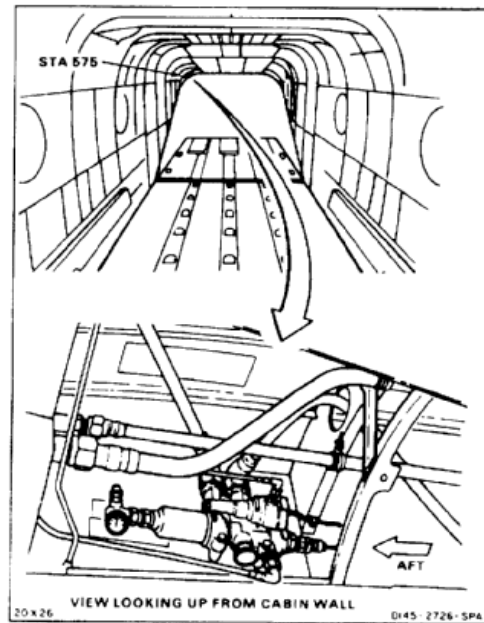

7-180 INSTALL APU START MODULE START VALVE (Continued)

7-180

1. Install valve (1) packing (2), two retainers (3), packing (4), two retainers (5), two packings (6), and four retainers (7) in APU START V port (8).
2. Lockwire valve (1). Use lockwire (E231).

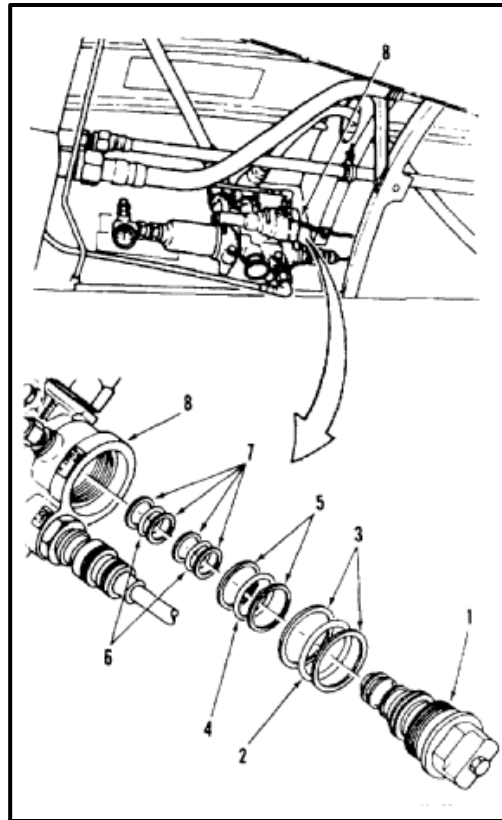
INSPECT**FOLLOW-ON MAINTENANCE:**

- Bleed utility hydraulic system (Task 7-336).
- Perform operational check (TM 55-1520-240-T).
- Close cargo ramp (TM 55-1520-240-T).

END OF TASK

INITIAL SETUP

Applicable Configurations:

All

Tools:

Aircraft Mechanic's Tool Kit, NSN 5180-00-323-4692
 Open-End Wrench, 1-1/4 Inch
 Container, 2 Quart

Materials:

Cloths (E135)

Personnel Required:

Medium Helicopter Repairer

Equipment Condition:

Battery Disconnected (Task 1-39)
 Electrical Power Off
 Hydraulic Power Off
 Cargo Ramp Open and Level (TM 55-1520-240-T)
 Utility Hydraulic System Depressurized (Task 7-135.1)

General Safety Instructions:**WARNING**

Hydraulic fluid (E199) is toxic. It can irritate skin and cause burns. Avoid inhaling. Use only with adequate ventilation. Avoid contact with skin, eyes, or clothing. In case of contact, immediately flush skin or eyes with water for at least **15 minutes**. Get medical attention for eyes.

WARNING

Hydraulic fluid ejected under pressure can cause injury to personnel.
 Hydraulic fluid sprayed into the air is a fire hazard.

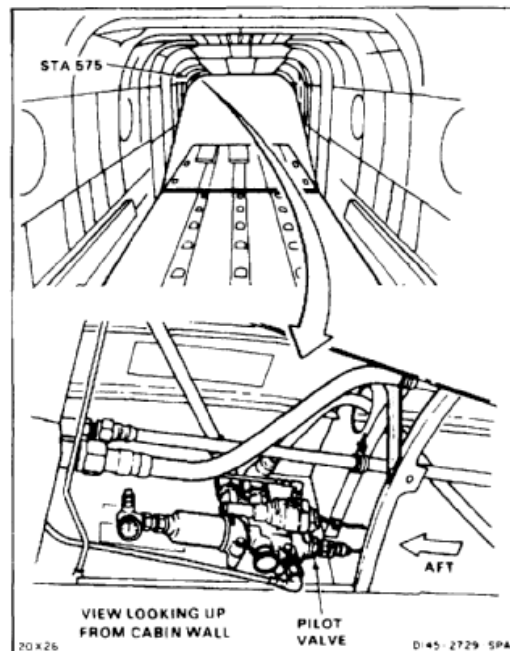

7-181 REMOVE APU START SOLENOID PILOT VALVE (Continued)

7-181

1. Disconnect connector (1) from valve (2).
2. Remove lockwire from valve (2). Remove valve, three packings (3) and six retainers (4) from START PLT V port (5). Use container and cloths (E135) for spilled fluid. Use gloves (E186).

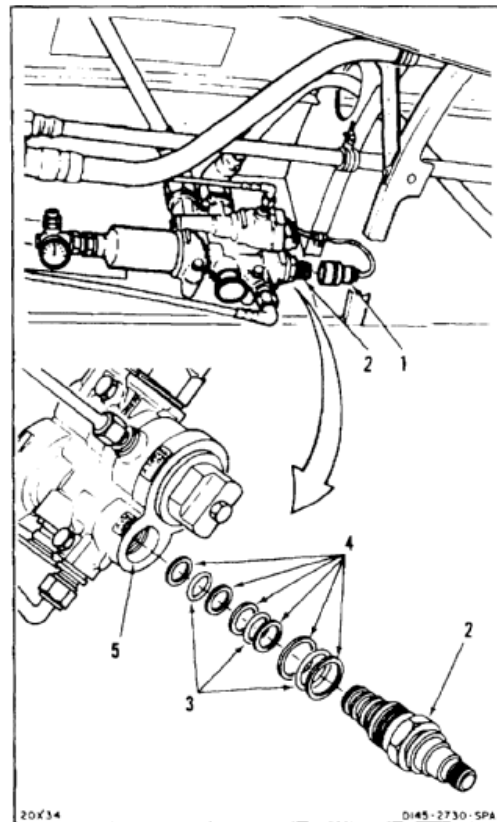
**FOLLOW-ON MAINTENANCE:**

None

END OF TASK

7-747

INITIAL SETUP

Applicable Configurations:

All

Tools:

Aircraft Mechanic's Tool Kit, NSN 5180-00-323-4692
 Crowfoot Attachment, 1 Inch
 Torque Wrench, 30 to 150 Inch-Pounds

Materials:

Lockwire (E231)

Parts:

Packings
 Retainers

Personnel Required:

Medium Helicopter Repairer
 Inspector

References:

TM 55-1520-240-23P

1. Install packing (1), packing (2), two retainers (3), packing (4), and two retainers (5) on valve (6).
2. Install valve (6) in START PLT V port (7). Torque valve to **60 inch-pounds**.
3. Lockwire valve (6). Use lockwire (E231).
4. Connect connector (8) to valve (6).

INSPECT**FOLLOW-ON MAINTENANCE:**

Perform operational check (TM 55-1520-240-T).
 Bleed utility hydraulic system (Task 7-335).
 Close cargo ramp TM 55-1520-240-T).

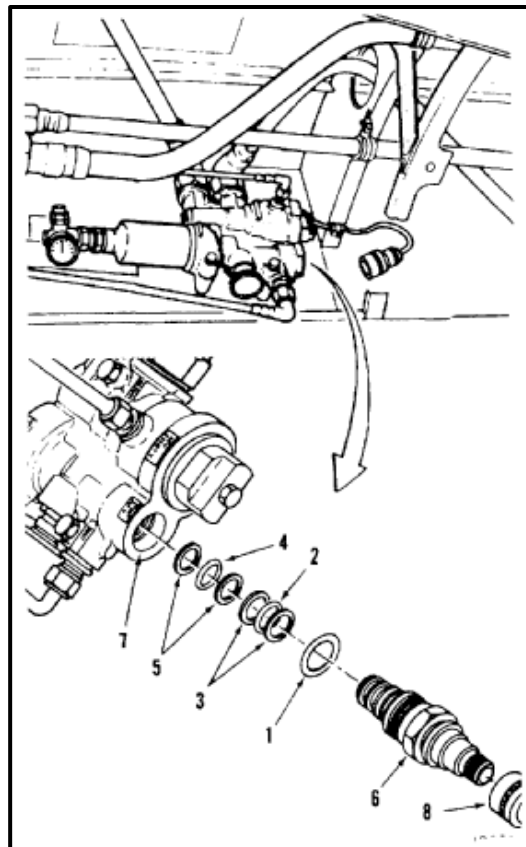
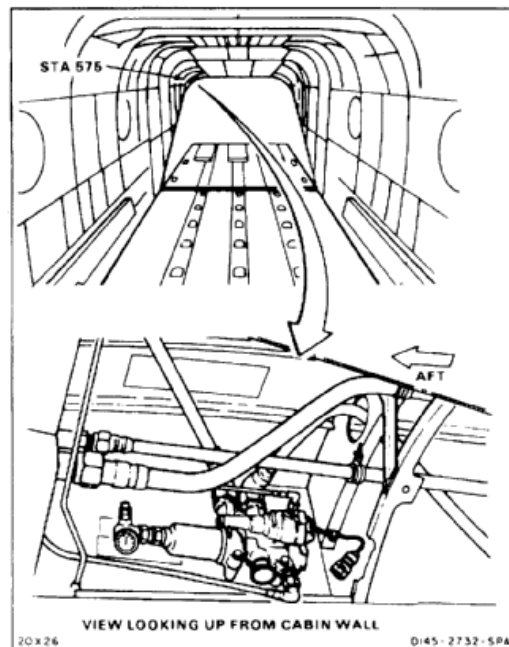

END OF TASK

7-748

INITIAL SETUP

Applicable Configurations:

All

Tools:

Aircraft Mechanic's Tool Kit, NSN 51 80-00-323-4692
Container, 2 Quart

Materials:

Cloths (E135)
Gloves (E186)

Personnel Required:

Medium Helicopter Repairer

Equipment Condition:

Battery Disconnected (Task 1-39)
Electrical Power Off
Hydraulic Power Off
Cargo Ramp Open and Level (TM 55-1520-240-T)
Utility Hydraulic System Depressurized (Task 7-135.1)

General Safety Instructions:**WARNING**

Hydraulic fluid (E199) is toxic. It can irritate skin and cause burns. Avoid inhaling. Use only with adequate ventilation. Avoid contact with skin, eyes, or clothing. In case of contact, immediately flush skin or eyes with water for at least **15 minutes**. Get medical attention for eyes.

WARNING

Hydraulic fluid ejected under pressure can cause injury to personnel. Hydraulic fluid sprayed into the air is a fire hazard.

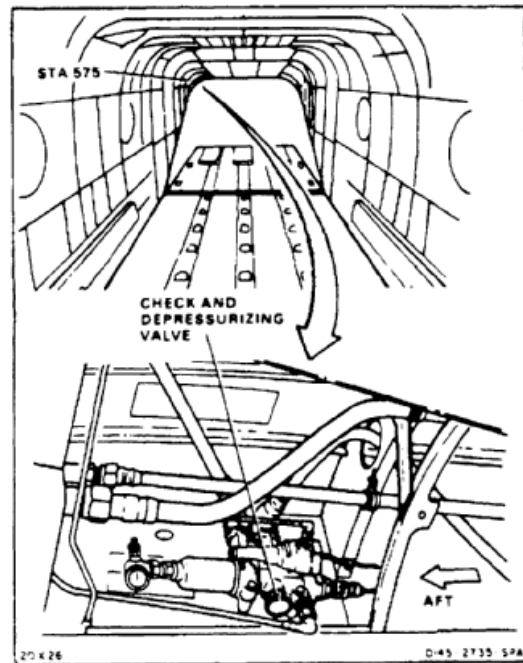

1. Remove lockwire from valve (1). Remove valve, three packings (2), and four retainers (3) from DEPRESS VALVE port (4). Use container and cloths (E135) for spilled fluid. Use gloves (E186).

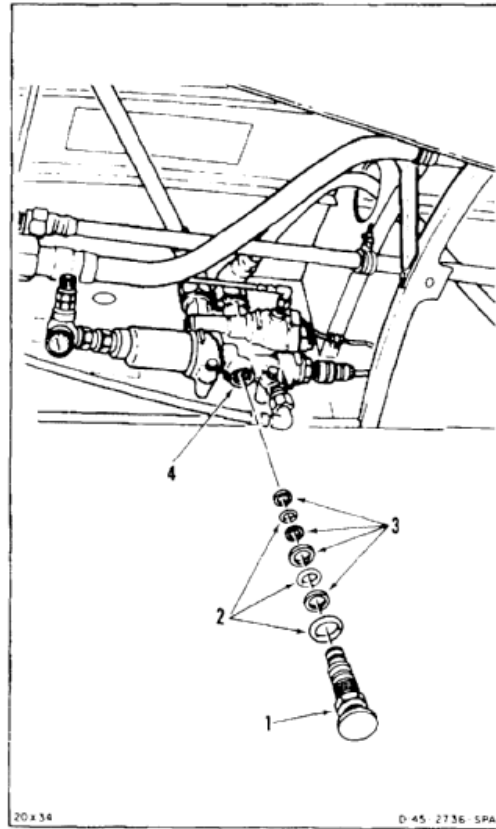
**FOLLOW-ON MAINTENANCE:**

None

END OF TASK

7-750

INITIAL SETUP

Applicable Configurations:

All

Tools:

Aircraft Mechanic's Tool Kit, NSN 5180-00-323-4692
Torque Wrench, 100 to 750 Inch-Pounds
Crowfoot Attachment, 7/8 Inch

Materials:

Lockwire (E231)

Parts:

Packings
Retainers

Personnel Required:

Medium Helicopter Repairer
Inspector

References:

TM 55-1520-240-23P

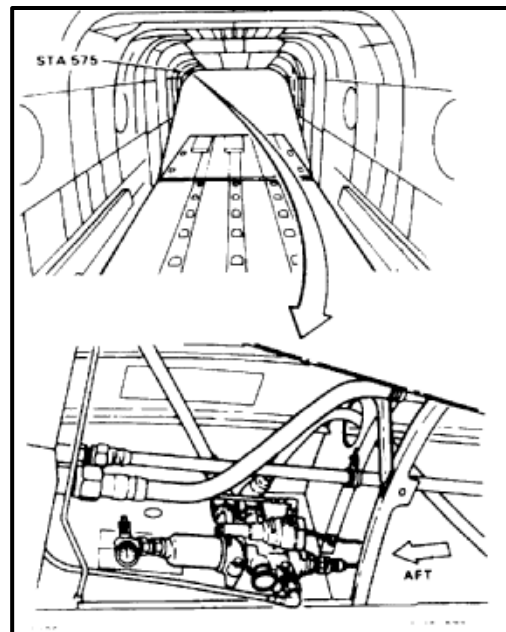

1. Install packing (1), four retainers (2), and two packings (3) on valve (4).
2. Install valve (4) in DEPRESS VALVE port (5). Torque valve to **175 inch-pounds**.
3. Lockwire valve (4). Use lockwire (E231).

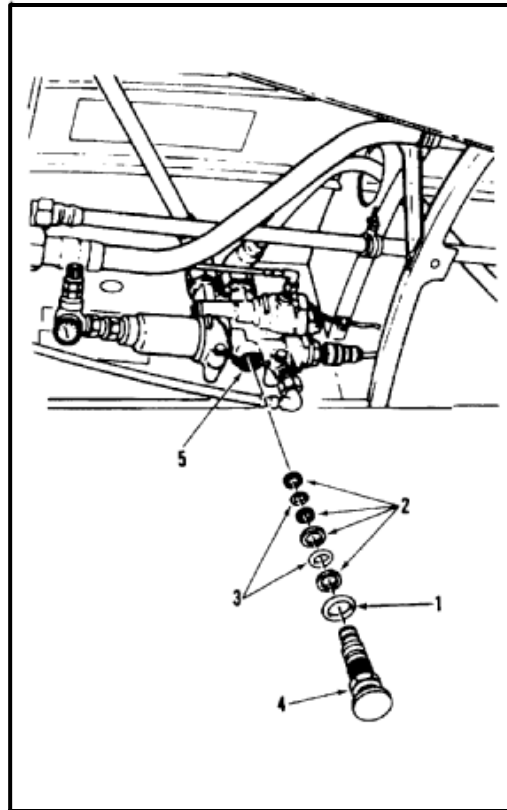
INSPECT**FOLLOW-ON MAINTENANCE:**

- Service APU accumulator (Task 1-64).
- Bleed utility hydraulic system (Task 7-335).
- Perform operational check (TM 55-1520-240-T).
- Close cargo ramp (TM 55-1520-240-T).

END OF TASK

7-752

INITIAL SETUP

Applicable Configurations:

All

Tools:

Aircraft Mechanic's Tool Kit, NSN 51 80-00-323-4692
Container, 2 Quart

Materials:

Cloths (E135)
Gloves (E186)

Personnel Required:

Medium Helicopter Repairer

Equipment Condition:

Battery Disconnected (Task 1-39)
Electrical Power Off
Hydraulic Power Off
Cargo Ramp Open and Level (TM 55-1520-240-10)
Utility Hydraulic System Depressurized (Task 7-135.1)
APU Start Module Accumulator Depressurized (Task 1-65)

General Safety Instructions:**WARNING**

Hydraulic fluid (E199) is toxic. It can irritate skin and cause burns. Avoid inhaling. Use only with adequate ventilation. Avoid contact with skin, eyes, or clothing. In case of contact, immediately flush skin or eyes with water for at least **15 minutes**. Get medical attention for eyes.

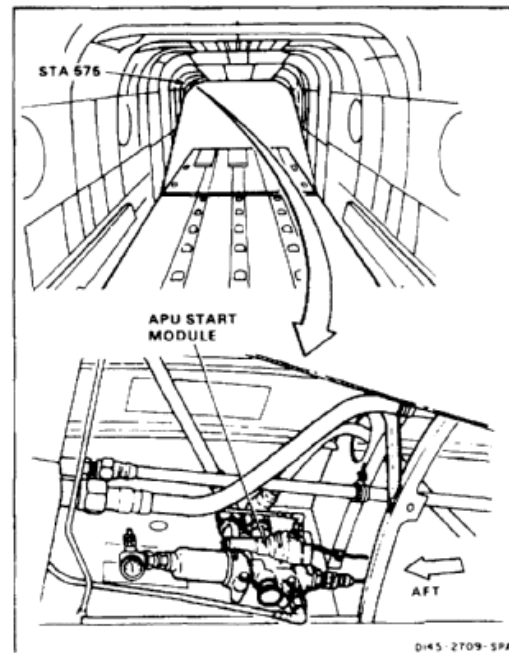

1. Disconnect connector (1) from module (2).
2. Tag and disconnect four tubes (3). Use container and cloths (E135) for spilled fluid. Use gloves (E186).
3. Remove three bolts (4) and washers (5).
4. Remove module (2).

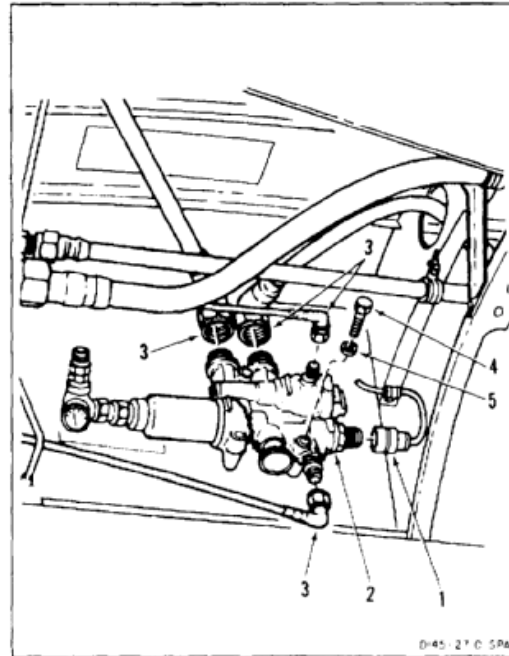
**FOLLOW-ON MAINTENANCE:**

None

END OF TASK

7-754

INITIAL SETUP

Applicable Configurations:

All

Tools:

Aircraft Mechanic's Tool Kit, NSN 5180-00-323-4692
Torque Wrench, 0 to 150 Inch-Pounds

Materials:

Cloths (E135)

Personnel Required:

Medium Helicopter Repairer
Inspector

References:

TM 55-1520-240-23P

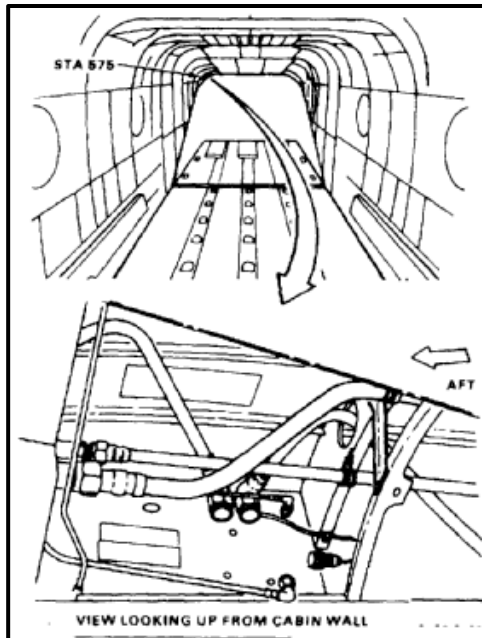

1. Position module (1). Install three bolts (2) and washers (3).

NOTE

Use cloths (E135) for spilled fluid.

2. Torque bolts (2) to **60 inch-pounds**.
3. Connect tube (4) to SUCT port (5). Remove tag.
4. Connect tube (6) to APU PRESS port (7). Remove tag.
5. Connect tube (8) to ACCUM port (9). Remove tag.
6. Connect tube (10) to SIG PRESS port (11). Remove tag.



Electrical connectors are to be tightened no more than **1/16 to 1/8 turn** beyond finger-tight during installation, otherwise they will be damaged.

7. Connect connector (12) to valve (13).

INSPECT

FOLLOW-ON MAINTENANCE:

Service APU accumulator (Task 1-64).
Bleed utility hydraulic system (Task 7-338).
Perform operational check (TM 55-1520-240-T).
Close cargo ramp (TM 55-1520-240-10).

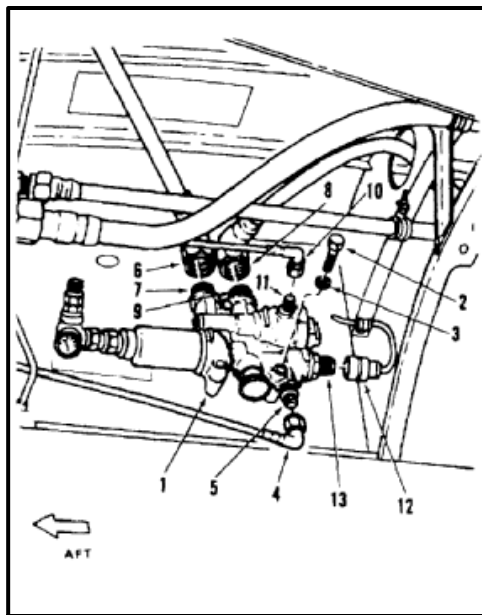

END OF TASK

INITIAL SETUP

Applicable Configurations:

All

Tools:

Aircraft Mechanic's Tool Kit, NSN 5180-00-323-4692
 Open-End Wrench, 1 Inch
 Open-End Wrench, 1-1/4 Inch
 Container, 2 Quart

Materials:

Cloths (E135)
 Paper Tags (E264)
 Gloves (E186)

Personnel Required:

Medium Helicopter Repairer (2)

References:

Task 7-349

Equipment Condition:

Battery Disconnected (Task 1-39)
 Electrical Power Off
 Hydraulic Power Off
 Utility Hydraulic System Depressurized (Task 7-135.1)
 Cargo Ramp Open and Level (TM 55-1520-240-10)

General Safety Instructions:**WARNING**

Hydraulic fluid (E199) is toxic. It can irritate skin and cause burns. Avoid inhaling. Use only with adequate ventilation. Avoid contact with skin, eyes, or clothing. In case of contact, immediately flush skin or eyes with water for at least **15 minutes**. Get medical attention for eyes.

WARNING

Hydraulic fluid ejected under pressure can cause injury to personnel. Hydraulic fluid sprayed into the air is a fire hazard.

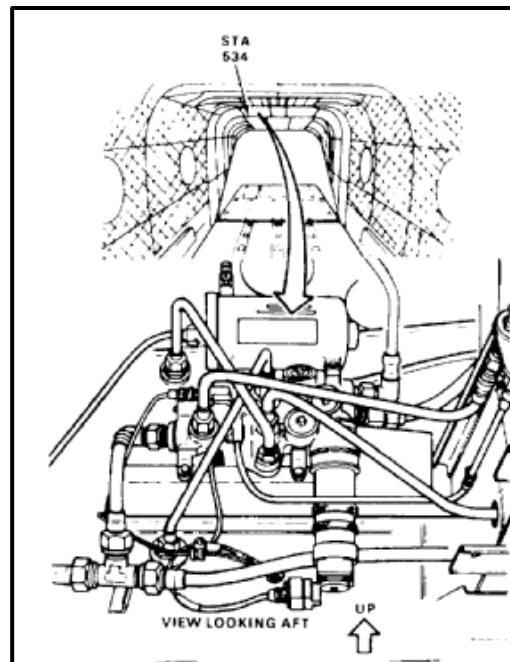

NOTE

If diaphragm must be removed, refer to Task 7-349.

1. Tag and disconnect three connectors (1) from module (2).
2. Tag and disconnect seven tubes (3) from module (2). Use container and cloths (E135) for spilled fluid. Use gloves (E186).
3. Tag and disconnect two tubes (4) from module (2). Use container and cloths (E135) for spilled fluid.
4. Have helper support module (2). Remove three bolts (5) and washers (6). Remove module (2).

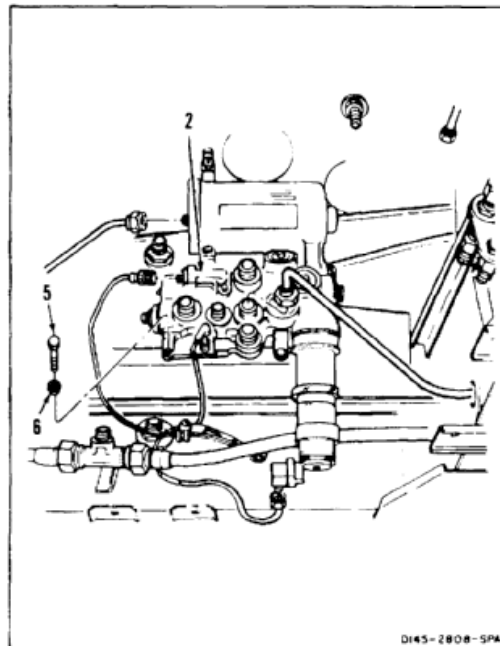
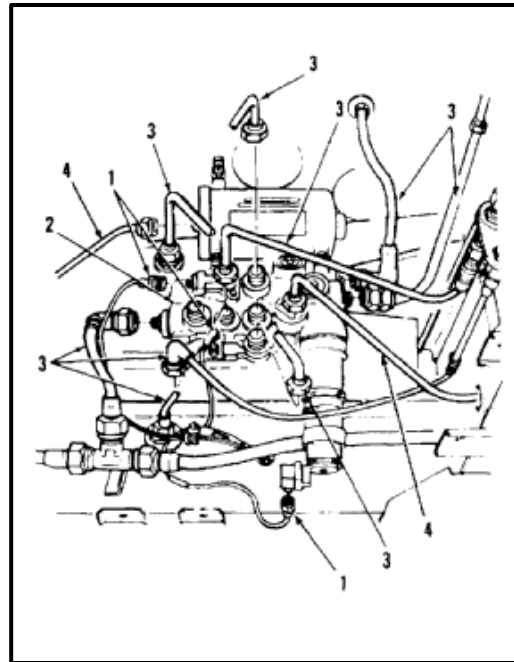
**FOLLOW-ON MAINTENANCE:**

None

END OF TASK

INITIAL SETUP

Applicable Configurations:

All

Tools:

Aircraft Mechanic's Tool Kit, NSN 5180-00-323-4692
 Open-End Wrench, 1 Inch
 Open-End Wrench, 1-1/4 Inch
 Torque Wrench, 100 to 750 Inch-Pounds

Materials:

Cloths (E135)

Personnel Required:

Medium Helicopter Repairer (2)
 Inspector

References:

TM 55-1520-240-23P
 Task 7-349

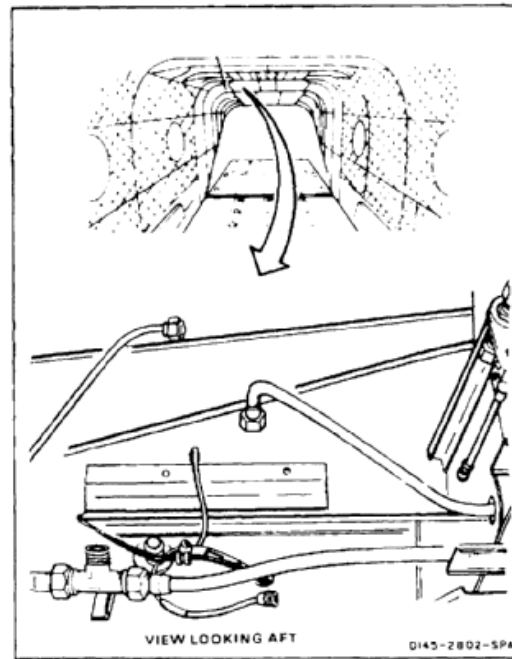
**NOTE**

If diaphragm was removed, refer to Task 7-349 for proper installation.

1. Position module (1). Have helper support module. Install three bolts (2) and washers (3). Torque to **145 to 200 inch-pounds**.
2. Connect tube (4) to cylinder (5). Connect opposite end. Remove tag.
3. Connect tube (6) to UTL CONT RTN port (7). Remove tag.
4. Connect tube (8) to FILL port (9) and fitting (10). Remove tag.
5. Connect tube (11) to FILTER RV port (12) and tube (13). Remove tag.
6. Connect tube (14) to UTIL PMP CD port (15) and fitting (16). Remove tag.

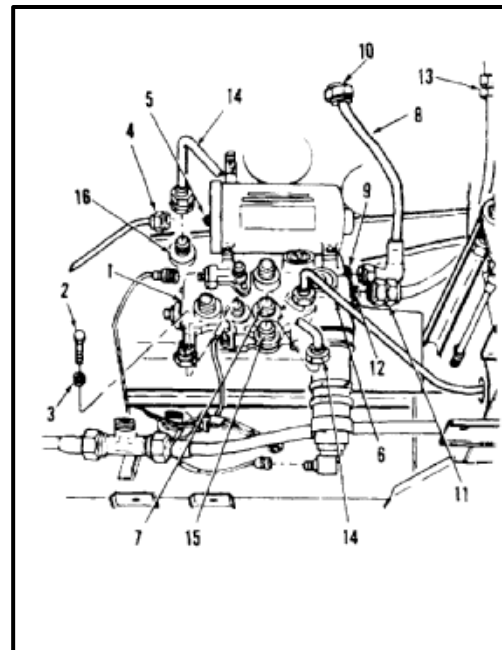

7. Connect tube (17) to PTU RTN port (18) and fitting (19). Remove tag.
8. Connect tube (20) to ENG ST RTN port (21) and tee (22). Remove tag.
9. Connect tube (23) to PWR STR RTN port (24) and fitting (25). Remove tag.
10. Connect tube (26) to APU CD port (27) and fitting (28). Connect opposite end. Remove tag.
11. Wipe up any spilled fluid. Use cloths (E135).



Electrical connectors are to be tightened no more than **1/16 to 1/8 turn** beyond finger-tight during installation, otherwise they will be damaged.

12. Connect connector (29) to receptacle (30). Remove tag.
13. Connect connector (24) to receptacle (31). Remove tag.
14. Connect connector (33) to receptacle (34). Remove tag.

INSPECT

FOLLOW-ON MAINTENANCE:

Perform operational check (TM 55-1520-240-T).
 Service utility hydraulic reservoir (Task 1-59 or 1-62).
 Close cargo ramp (TM 55-1520-240-10).

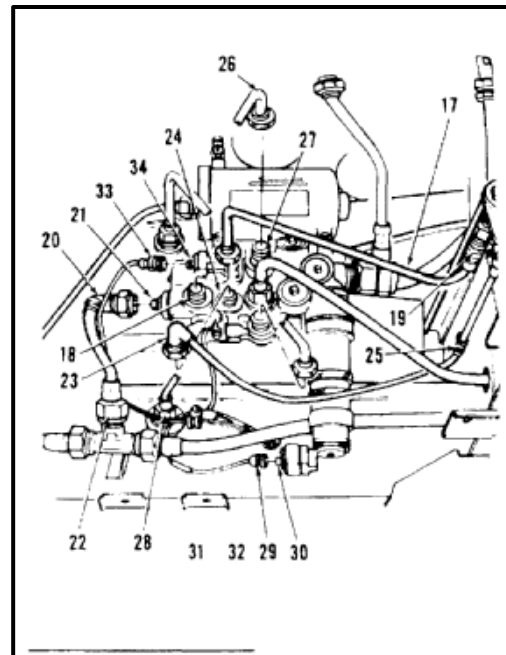

END OF TASK

INITIAL SETUP

Applicable Configurations:

All

Tools:

Aircraft Mechanic's Tool Kit, NSN 5180-00-323-4692
 Rubber Mallet
 Container, 14 Quart
 Hose, 6 Foot, 1/2 Inch Bore

Materials:

Cloths (E135)
 Gloves (E186)

Personnel Required:

Medium Helicopter Repairer (2)

Equipment Condition:

Battery Disconnected (Task 1-39)
 Electrical Power Off
 Hydraulic Power Off
 Utility Hydraulic System Depressurized (Task 7-135.1)
 Cargo Ramp Closed (TM 55-1520-240-10)

General Safety Instructions:**WARNING**

Hydraulic fluid (E199) is toxic. It can irritate skin and cause burns. Avoid inhaling. Use only with adequate ventilation. Avoid contact with skin, eyes, or clothing. In case of contact, immediately flush skin or eyes with water for at least **15 minutes**. Get medical attention for eyes.

WARNING

Hydraulic fluid ejected under pressure can cause injury to personnel. Hydraulic fluid sprayed into the air is a fire hazard.

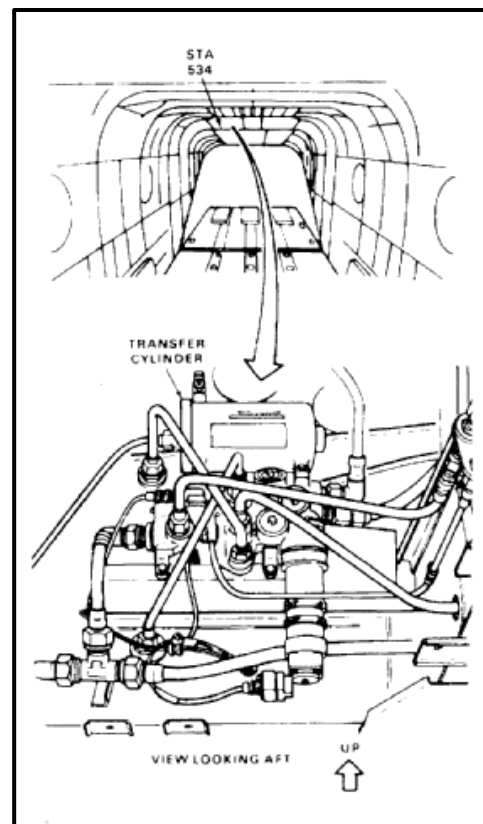

7-189 REMOVE UTILITY RETURN CONTROL MODULE TRANSFER CYLINDER (Continued)

7-189

1. Loosen standoff on tube (1). Disconnect tube (1) from cylinder (2).
2. Connect hose (3) from container (4) to port (5).
3. Force piston (6) into cylinder (2). Push piston or strike it with rubber mallet. Drain fluid into container (4). Use gloves (E186).
4. Remove hose (3) and container (4).
5. Remove lockwire from two bolts (7).
6. Have helper support cylinder (2). Remove two bolts (7) and washers (8).
7. Remove cylinder (2). Use cloths (E135) for spilled fluid.

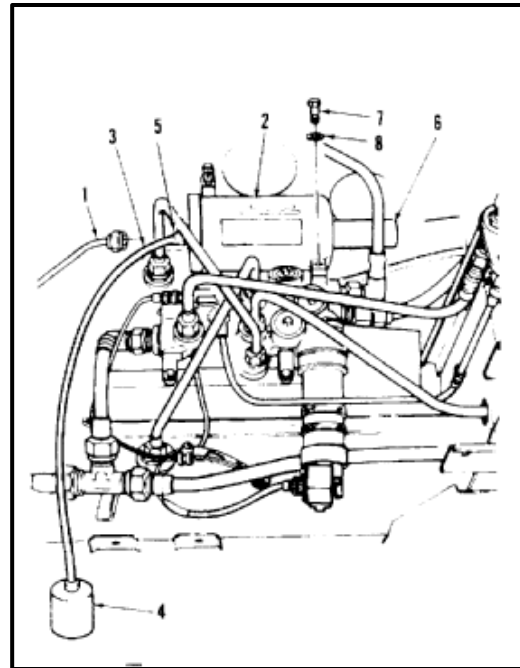

8. Remove lockwire from valve (9).
9. Remove valve (9) and packing (10) from port (11).
10. Remove two packings (12) from ports (13).

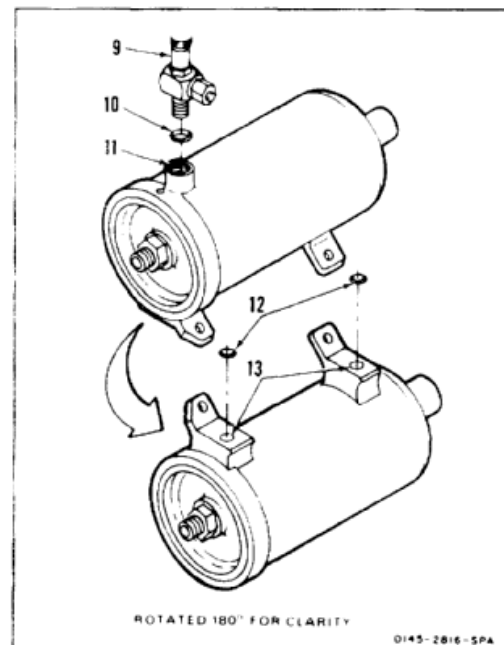
**FOLLOW-ON MAINTENANCE:**

None

END OF TASK

INITIAL SETUP

Applicable Configurations:

All

Tools:

Hydraulic Repairer's Tool Kit, NSN 5180-00-323-4891
 Deep Well Socket, 7/8 Inch
 Adapter, 3/8 to 1/2 Inch
 Container, 2 Quart
 Soft Jawed Vise
 Arbor Press
 Aluminum Rod, 1/2 Inch X 12 Inch
 Technical Inspection Tool Kit, NSN 5180-00-323-5114
 Outside Micrometer Calipers, 1 to 2 Inch and 3 to 4
 Inch
 Telescoping Gage Set

Materials:

Cloths (E120)

Personnel Required:

Aircraft Pneudraulics Repairer
 Inspector

References:

Task 7-1.1

Equipment Condition:

Off Helicopter Task

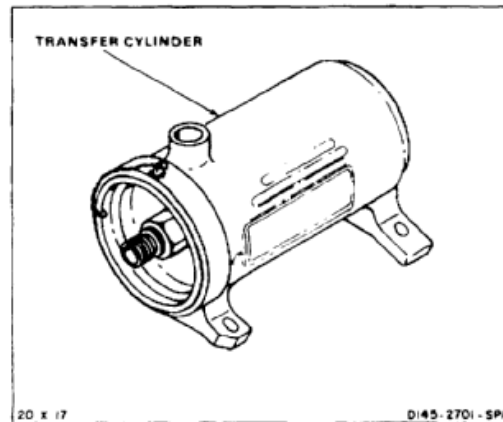
**NOTE**

General inspection criteria (Task 7-1.1) for obvious damage applies unless otherwise stated.

Inspection steps cover parts that are subject to wear.

1. Install cylinder (1) in vise (2).
2. Remove lockwire from cap (3) and cylinder (1).
3. Remove cap (3). Use **7/8 inch** deep well socket. Use container and cloths (E120) for spilled fluid.
4. Remove packing (4) from cap (3).

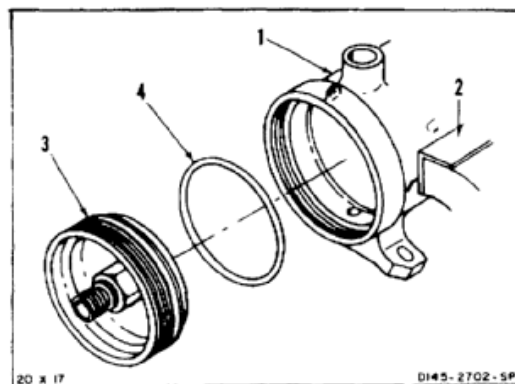

7-190 DISASSEMBLE AND INSPECT TRANSFER CYLINDER (AVIM) (Continued)

7-190

5. Remove piston (5) from cylinder (1). Push piston and shaft (6) from end of cylinder with rod (7) as shown. Use arbor press.
6. Remove two rings (8) and packing (9).
- 6.1. Inspect shaft (6). There shall be no nicks, scratches, or other damage.
- 6.2. Measure diameter of shaft (6). Diameter shall not be less than **1.246 inches**.
- 6.3. Measure diameter of two lands (6.1) of piston (5). Diameter shall not be less than **3.488 inches**.
7. Remove scraper ring (10) from end of cylinder (1).
8. Remove packing (11) from ring (10).
9. Remove two rings (12) and packing (13) from end of cylinder (1).
- 9.1. Measure inside diameter of cylinder (1). Diameter shall not be more than **3.495 inches**.
- 9.2. Measure diameter of two lands (14) in bore at end of cylinder (1). Diameter shall not be more than **1.253 inches**.
10. Remove cylinder (1) from vise (2).

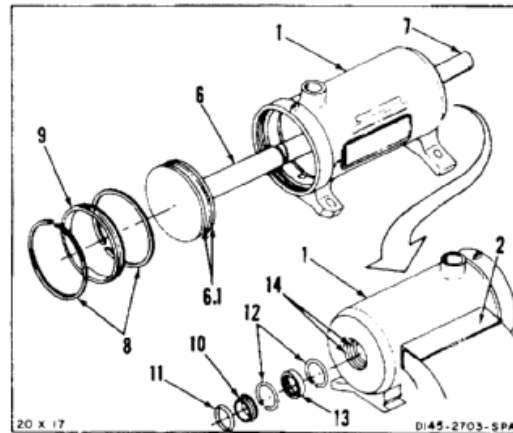
**INSPECT****FOLLOW-ON MAINTENANCE:**

None

END OF TASK

INITIAL SETUP

Applicable Configurations:

All

Tools:

Hydraulic Repairer's Tool Kit, NSN 5180-00-323-4891
 Deep Well Socket, 7/8 Inch
 Soft Jawed Vise
 Aluminum Rod, 1/2 Inch X 12 Inches

Materials:

Lockwire (E229)
 Hydraulic Fluid (E199)
 Cloths (E120)

Parts:

Preformed Packings
 Ring
 Scraper Ring

Personnel Required:

Aircraft Pneudraulics Repairer
 Inspector

References:

TM 55-1520-240-23P

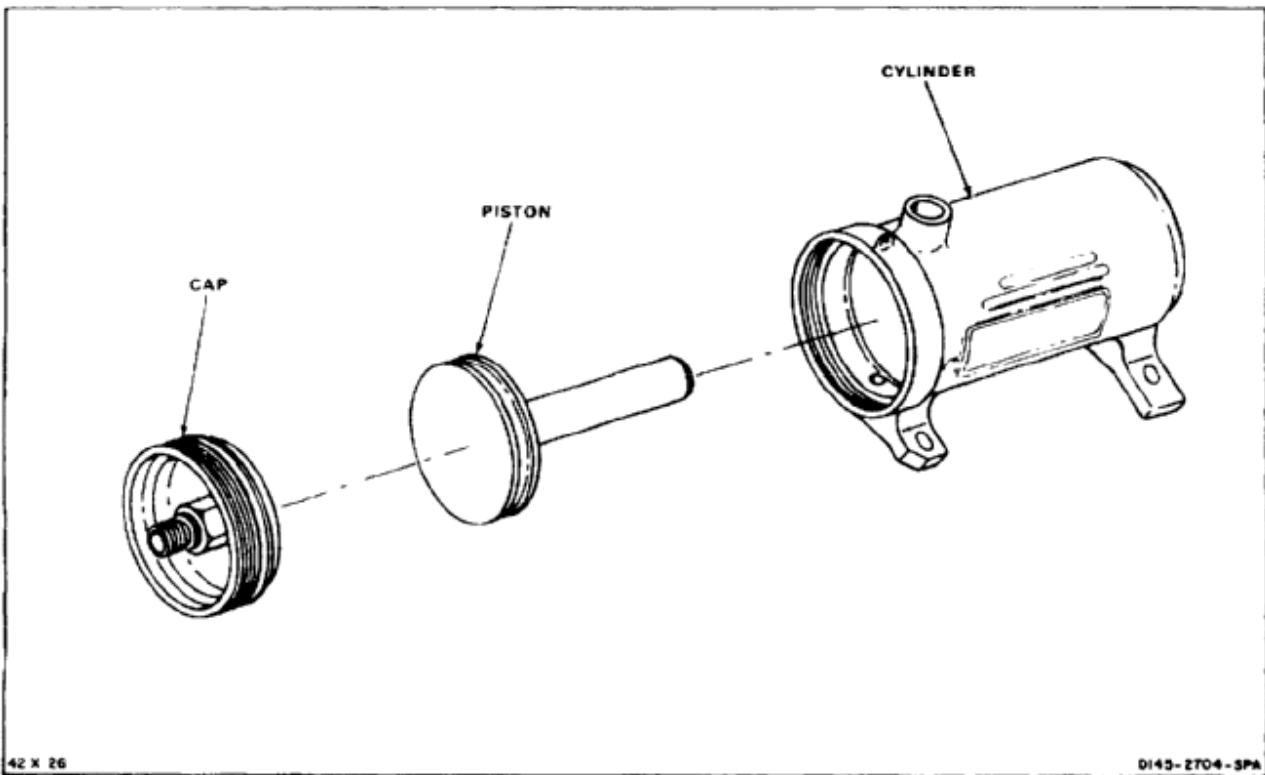

7-191 ASSEMBLE TRANSFER CYLINDER (AVIM) (Continued)

7-191

1. Install cylinder (1) in vise (2).
2. Install packing (3), two rings (4 and 5). Position slots in rings **180°** apart.
3. Install packing (6) on scraper ring (7).
4. Install ring (7) in end of cylinder (1), large diameter inward.

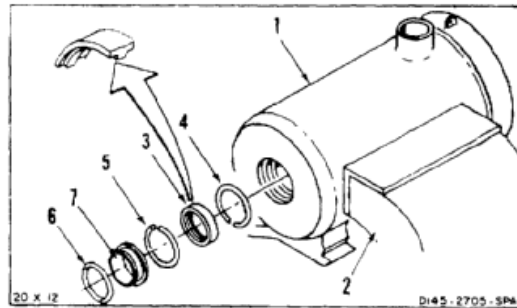

5. Install packing (8) and two rings (9 and 10) on piston (11). Position slots in rings **180°** apart.
6. Lubricate shaft (12) and walls of cylinder (1) with hydraulic fluid (E199). Use cloth (E120) for spilled fluid.
7. Install piston (11) in cylinder (1) until shaft (12) extends past other end of cylinder. Use rod (13) or wood hammer handle to push piston.

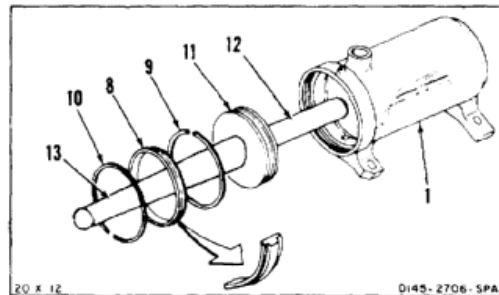

8. Install packing (14) on cap (15).
9. Install cap (15) in cylinder (1), until cap is flush to **0.010 inch** from end of cylinder as shown. Use **7/8 inch** deep well socket and adapter. Use feeler gage to check cap height.
10. Lockwire cap (15) to lug (16) on cylinder (1). Use lockwire (E229).
11. Remove cylinder (1) from vise (2).

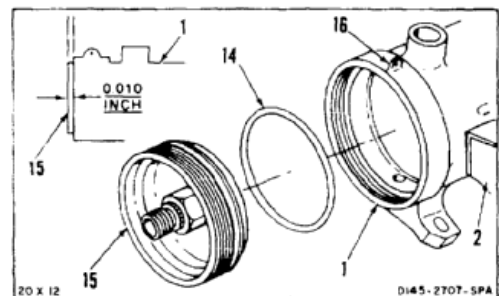
**INSPECT****FOLLOW-ON MAINTENANCE:**

Perform operational test (Task 7-192).

END OF TASK

INITIAL SETUP

Applicable Configurations:

All

Tools:

- Hydraulic Repairer's Tool Kit, NSN 5180-00-323-4891
- Test Manifold (145G0054)
- Hydraulic Test Stand
- Soft Jawed Vise
- Container, 2 Quart
- Shutoff Valve (4)
- Pressure Gage, 500 psi (2)
- Regulator Valve
- Regulator Valve, Three-Way
- Tube, 1/4 Inch, 400 psi
- Tee, 1/4 Inch (4)
- Nipples, 1/4 Inch
- Stop Watch

Materials:

- Hydraulic Fluid (E199)
- Cloths (E120)
- Gloves (E186)

Parts:

- Preformed Packing
- Nuts
- Bolts
- Washers
- Plugs

Personnel Required:

- Aircraft Pneudraulics Repairer
- Inspector

Equipment Condition:

- Off Helicopter Task
- Transfer Cylinder Installed In Crash Proof Box
- Test Setup

General Safety Instructions:

WARNING

Use suitable crash box to shield personnel and equipment in case of failure during test.

WARNING

Hydraulic fluid (E199) is toxic. It can irritate skin and cause burns. Avoid inhaling. Use only with adequate ventilation. Avoid contact with skin, eyes, or clothing. In case of contact, immediately flush skin or eyes with water for at least **15 minutes**. Get medical attention for eyes.

WARNING

Hydraulic fluid ejected under pressure can cause injury to personnel. Hydraulic fluid sprayed into the air is a fire hazard.

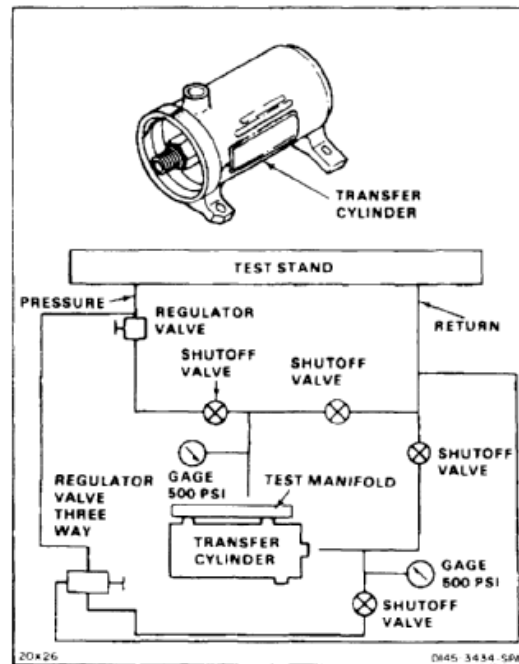

1. Install cylinder (1) in vise (2) with ports (3 and 4) up.
2. Install plug (5) in port (6).
3. Connect test setup to port (7) of cylinder (1).
4. Close valves (8, 9, and 10).
5. Open valve (11).
6. Adjust valve (12) to supply fluid (E199) to port (7) until fluid at port (4) is air free. Use cloth (E120) for spilled fluid. Use gloves (E186).
7. Close valve (11).
8. Fill cylinder (1) with fluid (E199) through port (3). Use container.
9. Install two packings (13 and 14) in ports (3 and 4).
10. Position manifold (15) on cylinder (1). Install two bolts (16), washers (17), and nuts (18).

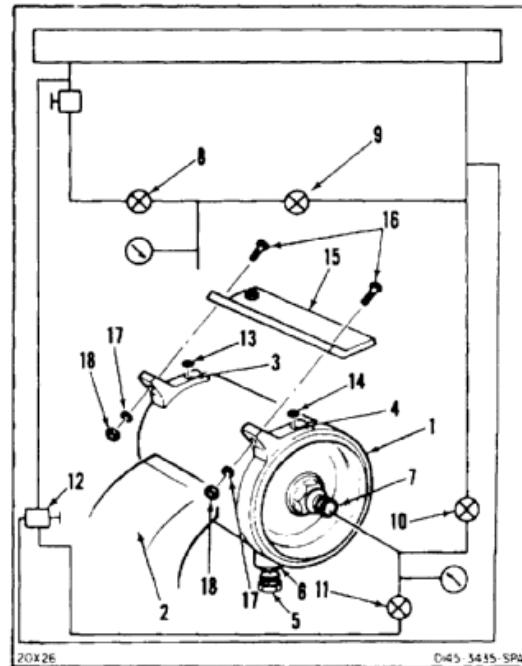

INTEGRITY PRESSURE AND LEAKAGE TEST

11. Connect test setup to port (19) of manifold (15).
12. Open valves (8 and 11).
13. Apply **375 psi** pressure to port (7 and 19). Adjust valves (12 and 20) for **375 psi** on gages (21 and 22). Maintain pressure for **2 minutes**.
14. Check for leaks at seals (23 and 24). There shall be no leaks.

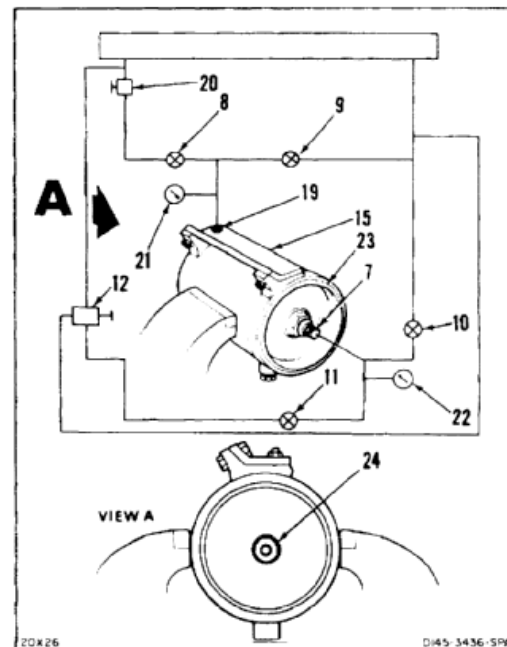

OPERATIONAL AND LEAKAGE TEST

15. Apply **50 psi** pressure to port (7 and 19). Adjust valves (12 and 20) for **50 psi** on gages (21 and 22). Maintain pressure until rod (25) stops moving.
16. Adjust valve (12) for **30 psi** on gage (22). Maintain pressure until (25) stops moving.
17. Repeat steps 15 and 16 **twenty-five times**, then go to step 18.
18. Check for leaks at seal (24). There shall be no leaks.
19. Close valve (8). Open valve (9). Check for **0 psi** on gage (21).

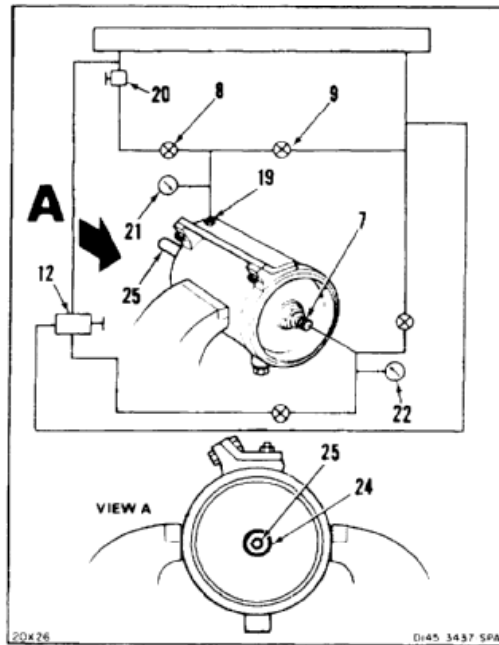

20. Close valve (9). Disconnect test setup from port (19). Use cloths (E120) for spilled fluid.
21. Apply **50 psi** pressure to port (7). Adjust valve (12) for **50 psi** on gage (22). Maintain pressure for **30 minutes**.
22. Check for leaks at port (19). Leaks shall not exceed **1 drop**.
23. Connect test setup to port (19).

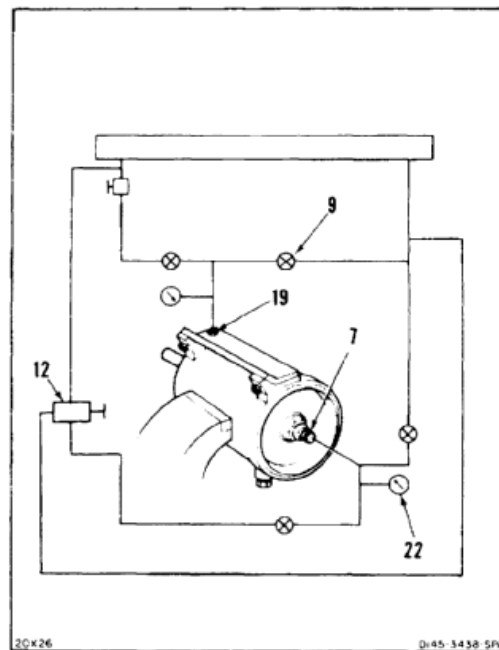

24. Open valve (8).
25. Close valve (11). Open valve (10). When rod (25) stops moving, check for **0 psi** on gage (22).
26. Close valve (10). Disconnect test setup from port (7). Use cloths (E120) for spilled fluid.
27. Apply **50 psi** pressure to port (19). Adjust valve (20) for **50 psi** on gage (21). Maintain pressure for **30 minutes**.
28. Check for leaks at seal (24) and port (7). Leak shall not exceed **1 drop**.
29. Close valve (8). Open valve (9). Check for **0 psi** on gage (21).
30. Disconnect test setup from port (19). Use cloths (E120) for spilled fluid.

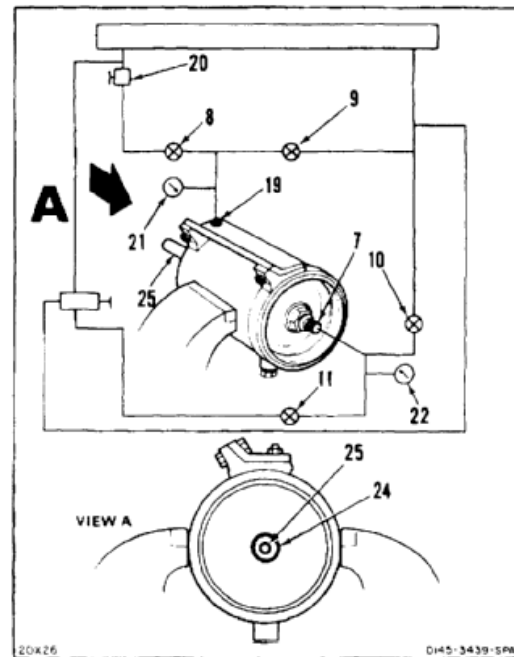

31. Remove two bolts (16), washers (17), and nuts (18). Remove manifold (15) from cylinder (1).
32. Remove two packings (13 and 14) from ports (3 and 4) of cylinder (1).
33. Remove plugs (5) from port (6).
34. Remove cylinder (1) from vise (2).

INSPECT

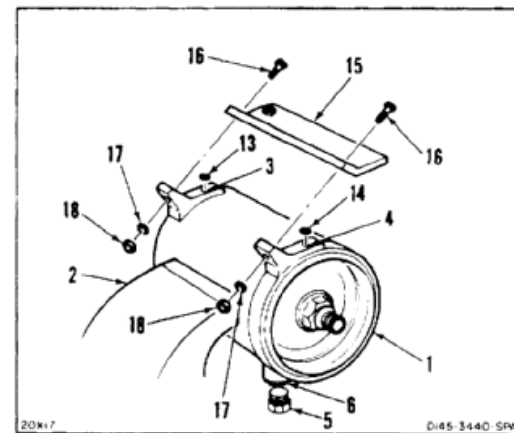

FOLLOW-ON MAINTENANCE:

None

END OF TASK

INITIAL SETUP

Applicable Configurations:

All

Tools:

Aircraft Mechanic's Tool Kit, NSN 5180-00-323-4692
Torque Wrench, 5 to 50 Inch-Pounds

Materials:

Cloths (E135)
Lockwire (E231)

Parts:

Preformed Packings

Personnel Required:

Medium Helicopter Repairer (2)
Inspector

References:

TM 55-1520-240-23P

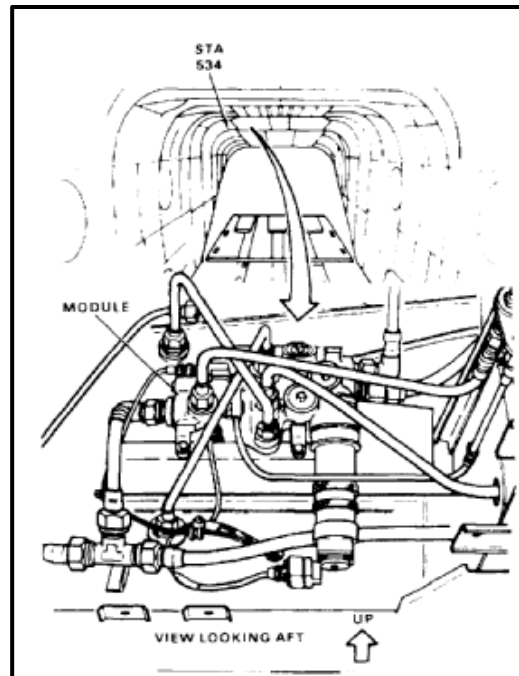

1. Install valve (1) and packing (2) in port (3).
2. Lockwire valve (1) to cylinder (4). Use lockwire (E231).
3. Install packing (5) in port (6) and packing (7) in port (8).

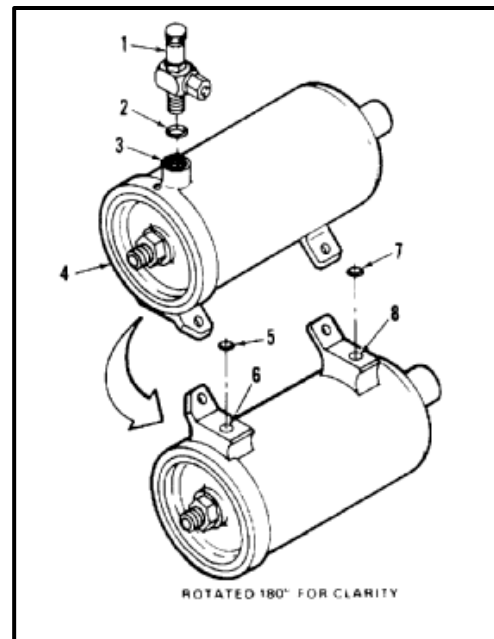

7-193 INSTALL RAMP TRANSFER CYLINDER (Continued)

7-193

4. Position cylinder (4) on module (9). Have helper hold cylinder.
5. Install two bolts (10) and washers (11). Torque bolts to **28 inch-pounds**. Check for gap between cylinder (4) and module (9).
6. Lockwire bolts (10) to module (9). Use lockwire (E231).
7. Connect tube (12) to port (13). Tighten tube clamp.

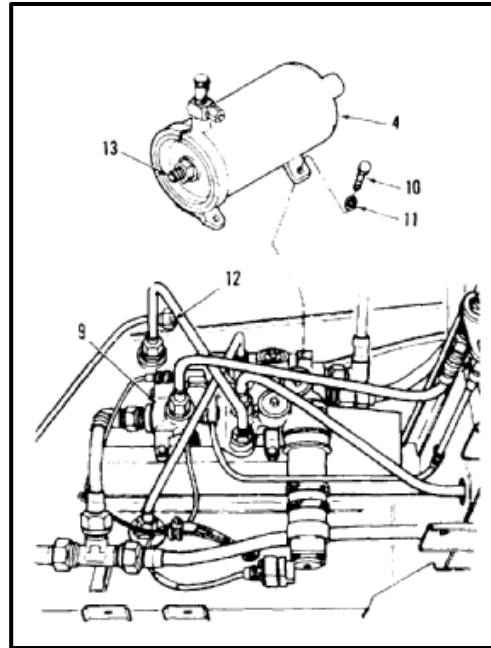
INSPECT**FOLLOW-ON MAINTENANCE:**

- Perform operational check (TM 55-1520-240-T).
- Service utility hydraulic reservoir (Task 1-59 or 1-62).
- Close cargo ramp (TM 55-1520-240-10).

END OF TASK

INITIAL SETUP

Applicable Configurations:

All

Tools:

Aircraft Mechanic's Tool Kit, NSN 5180-00-323-4692
 Container, 2 Quart
 Strap Wrench

Materials:

Cloths (E135)
 Gloves (E186)

Personnel Required:

Medium Helicopter Repairer

Equipment Condition:

Battery Disconnected (Task 1-39)
 Electrical Power Off
 Hydraulic Power Off
 Utility Hydraulic System Depressurized (Task 7-135.1)
 Cargo Ramp Open and Level (TM 55-1520-240-10)

General Safety Instructions:**WARNING**

Hydraulic fluid (E199) is toxic. It can irritate skin and cause burns. Avoid inhaling. Use only with adequate ventilation. Avoid contact with skin, eyes, or clothing. In case of contact, immediately flush skin or eyes with water for at least **15 minutes**. Get medical attention for eyes.

WARNING

Hydraulic fluid ejected under pressure can cause injury to personnel. Hydraulic fluid sprayed into the air is a fire hazard.

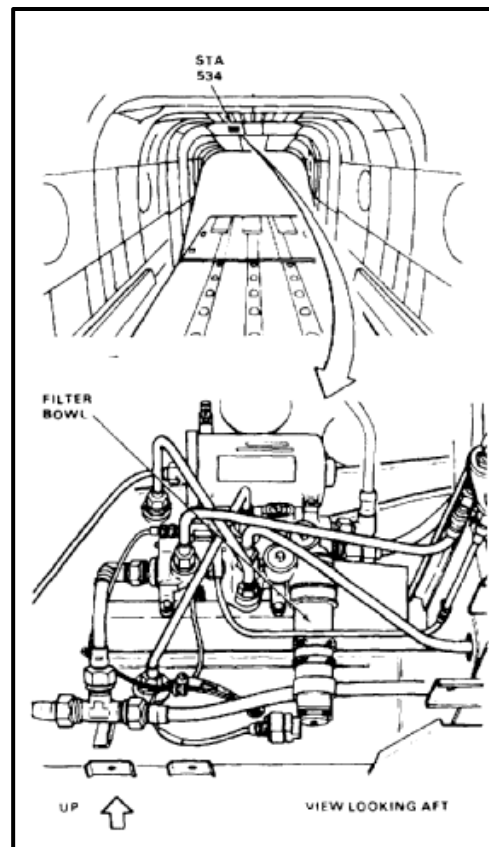

7-194 REMOVE UTILITY RETURN CONTROL MODULE FILTER ELEMENT (Continued)

7-194

1. Disconnect connector (1) from indicator (2).
2. Remove lockwire from bowl (3). Remove bowl from module (4). Use strap wrench. Use container and cloths (E135) for spilled fluid. Wear gloves (E186).
- 2.1. Remove retainer (4.1) and packings (4.2 and 4.3).

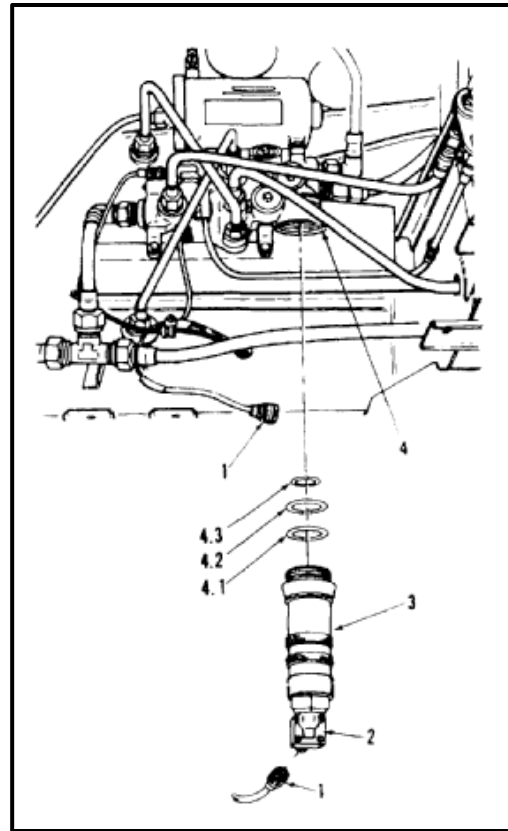

3. Remove filter element (5) from bowl (3).

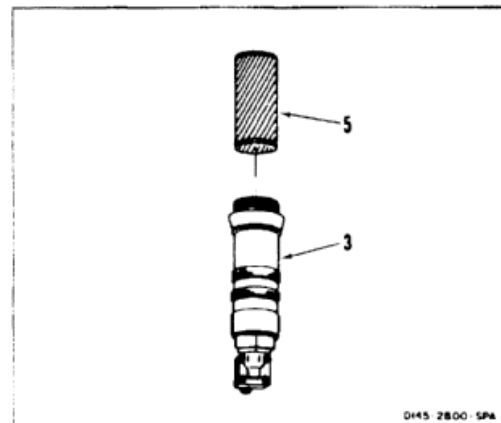
**FOLLOW-ON MAINTENANCE:**

None

END OF TASK

7-773

INITIAL SETUP

Applicable Configurations:

All

Tools:

Aircraft Mechanic's Tool Kit, NSN 5180-00-323-4692

Materials:

Lockwire (E230)

Parts:

Preformed Packings
 Retainer
 Filter Element
 Medium Helicopter Repairer
 Inspector

References:

TM 55-1520-240-23P

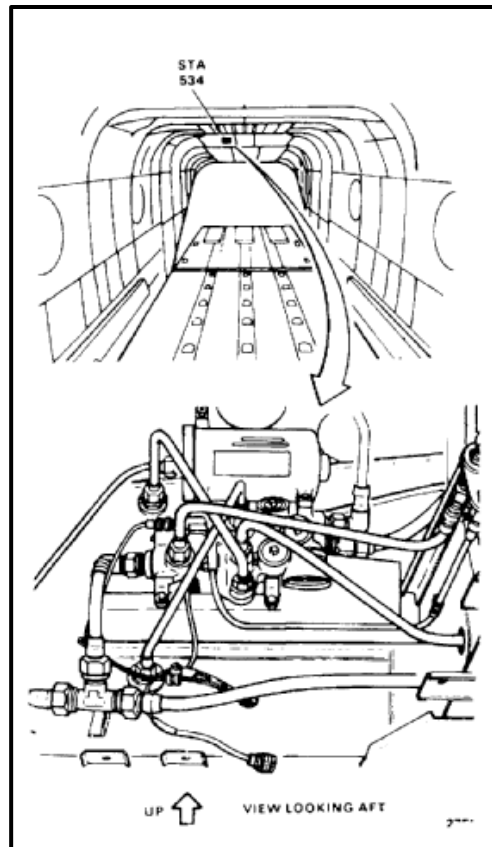

1. Install filter element (1) in bowl (2).

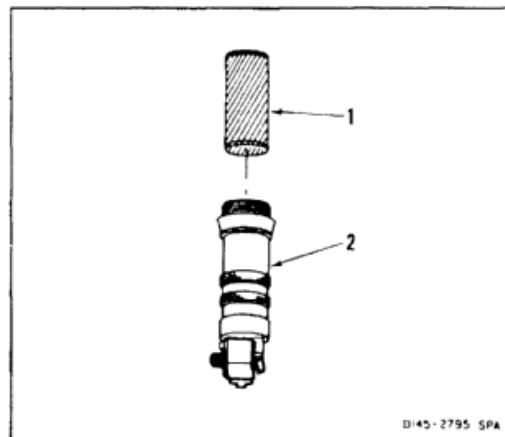

7-195 INSTALL UTILITY RETURN CONTROL MODULE FILTER ELEMENT (Continued)

7-195

- 1.1. Install packings (2.1 and 2.2) and retainer (2.3), in FILTER port (3).
2. Install bowl (2) in FILTER port (3). Lockwire bowl. Use lockwire (E230).
3. Connect connector (4) to indicator (5).

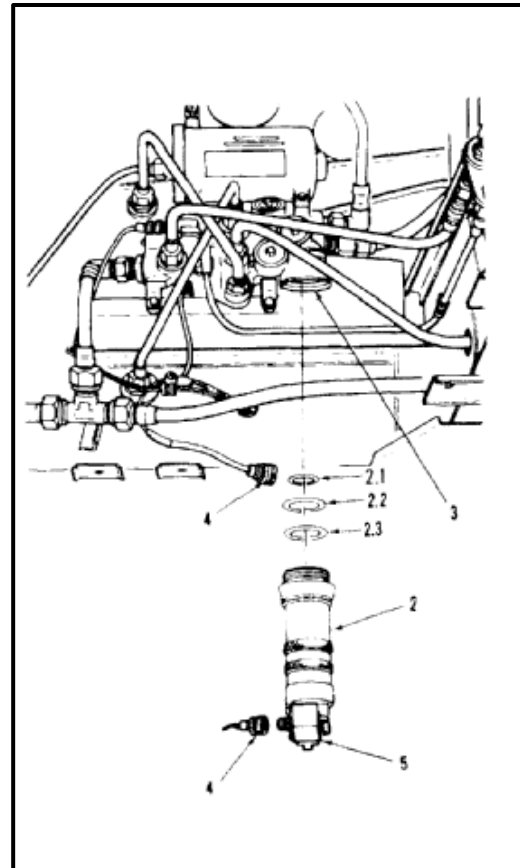
INSPECT**FOLLOW-ON MAINTENANCE:**

- Perform operational check (TM 55-1520-240-T).
- Service utility hydraulic reservoir (Task 1-59 or 1-62).
- Perform operational check (TM 55-1520-240-T).
- Close cargo ramp (TM 55-1520-240-10).

END OF TASK

INITIAL SETUP

Applicable Configurations:

All

Tools:

Aircraft Mechanic's Tool Kit, NSN 5180-00-323-4692
Container, 2 Quart

Materials:

Cloths (E135)
Gloves (E186)

Personnel Required:

Medium Helicopter Repairer

Equipment Condition:

Battery Disconnected (Task 1-39)
Electrical Power Off
Hydraulic Power Off
Utility Hydraulic System Depressurized (Task 7-135.1)
Cargo Ramp Open and Level (TM 55-1 520-240-10)

General Safety Instructions:**WARNING**

Hydraulic fluid (E199) is toxic. It can irritate skin and cause burns. Avoid inhaling. Use only with adequate ventilation. Avoid contact with skin, eyes, or clothing. In case of contact, immediately flush skin or eyes with water for at least **15 minutes**. Get medical attention for eyes.

WARNING

Hydraulic fluid ejected under pressure can cause injury to personnel. Hydraulic fluid sprayed into the air is a fire hazard.

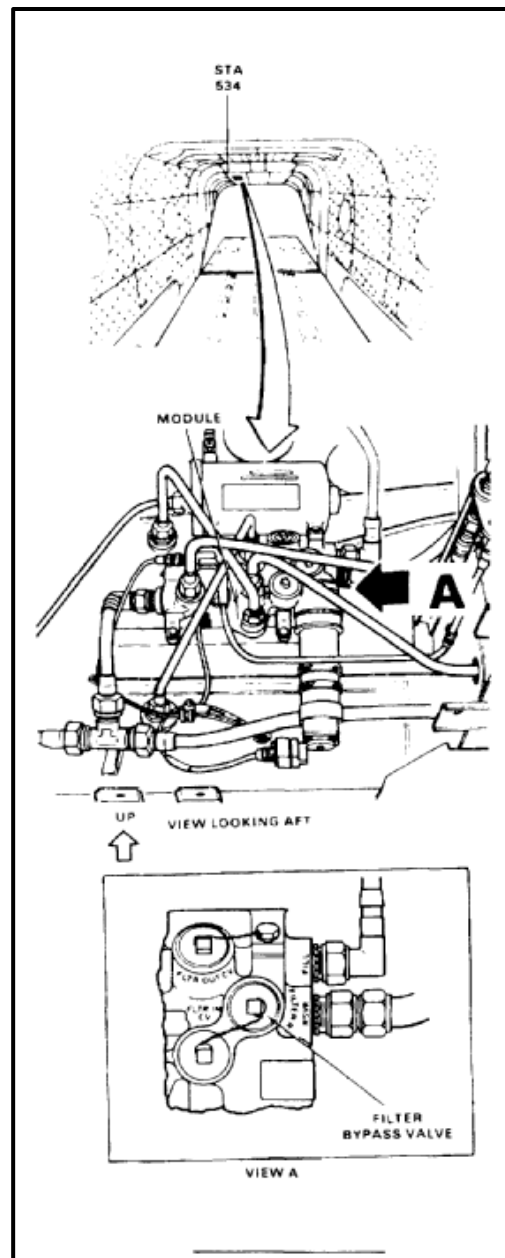

7-196 REMOVE UTILITY RETURN CONTROL MODULE FILTER BYPASS VALVE (Continued)**7-196**

1. Remove lockwire from valve (1).
2. Remove valve (1) and two packings (2) from FILTER RV port (3). Use container and cloths (E135) for spilled fluid. Use gloves (E186).

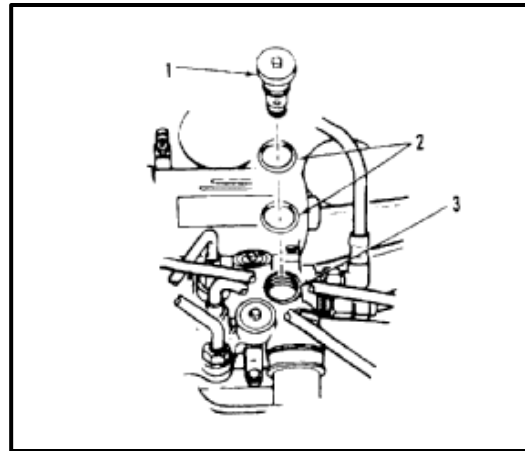
***FOLLOW-ON MAINTENANCE:***

None

END OF TASK

INITIAL SETUP

Applicable Configurations:

All

Tools:

Aircraft Mechanic's Tool Kit, NSN 5180-00-323-4692

Materials:

Lockwire (E231)

Parts:

Preformed Packings

Personnel Required:Medium Helicopter Repairer
Inspector**References:**

TM 55-1520-240-23P

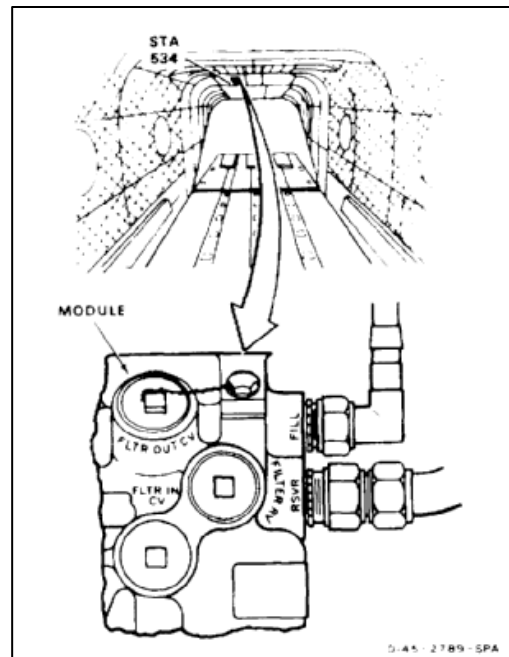

1. Install valve (1) and two packings (2) in FILTER RV port (3). Tighten snug but do not overtighten.
2. Lockwire valve (1) to FLTR INC CV VALVE (4). Use lockwire (E231).

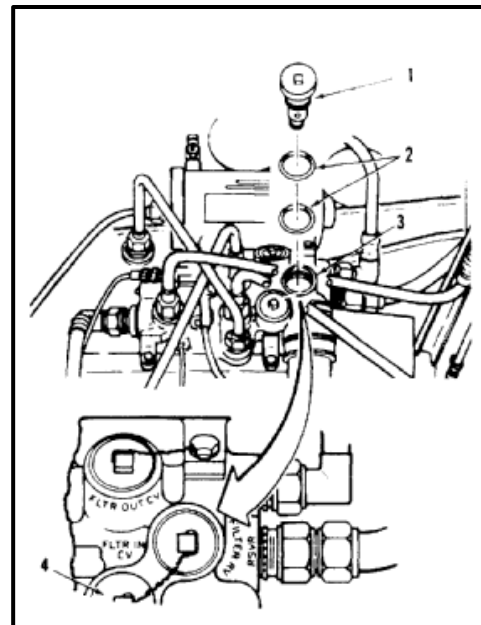
INSPECT**FOLLOW-ON MAINTENANCE:**

Service utility hydraulic reservoir (Task 1-59 or 1-62).
 Perform operational check (TM 55-1520-240-T).
 Close cargo ramp (TM 55-1520-240-10).

END OF TASK

7-778

INITIAL SETUP

Applicable Configurations:

All

Tools:

Aircraft Mechanic's Tool Kit, NSN 51 80-00-323-4692
 Container, 2 Quart
 Socket Key, 9/16 Inch

Materials:

Cloths (E135)
 Gloves (E186)

Personnel Required:

Medium Helicopter Repairer

General Safety Instructions:**WARNING**

Hydraulic fluid (E199) is toxic. It can irritate skin and cause burns. Avoid inhaling. Use only with adequate ventilation. Avoid contact with skin, eyes, or clothing. In case of contact, immediately flush skin or eyes with water for at least **15 minutes**. Get medical attention for eyes.

WARNING

Hydraulic fluid ejected under pressure can cause injury to personnel. Hydraulic fluid sprayed into the air is a fire hazard.

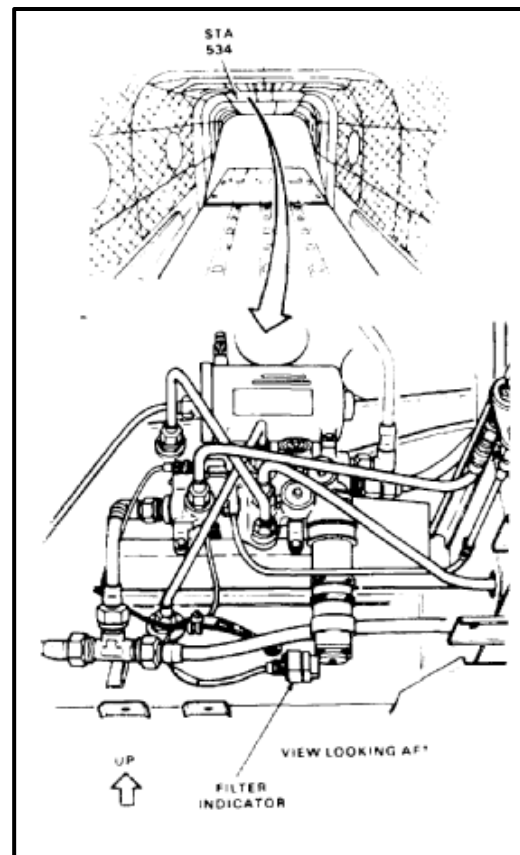

1. Disconnect connector (1) from indicator (2). Use gloves (E186).
2. Remove lockwire from four screws (3).
3. Remove four screws (3) from indicator (2).
4. Remove indicator (2), two retainers (4), and packing (5).

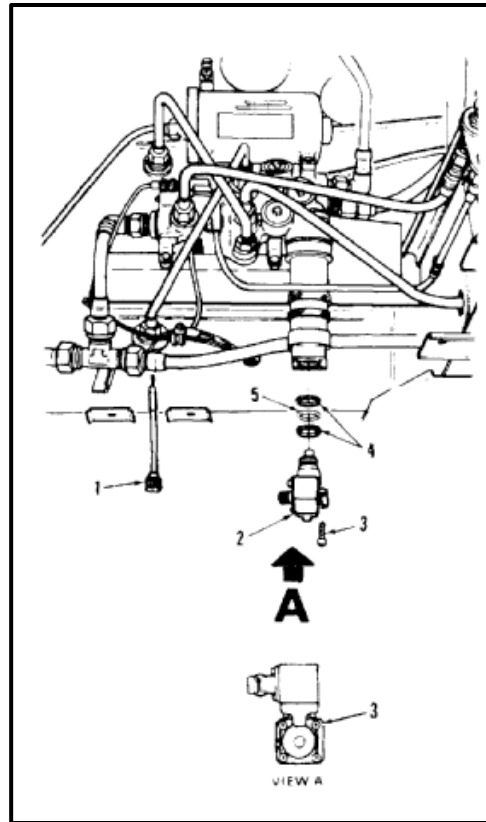
**FOLLOW-ON MAINTENANCE:**

None

END OF TASK

7-780

7-199 INSTALL UTILITY RETURN CONTROL MODULE FILTER INDICATOR

7-199

INITIAL SETUP**Applicable Configurations:**

All

Tools:

Aircraft Mechanic's Tool Kit, NSN 5180-00-323-4692
Torque Wrench, 5 to 50 Inch-Pounds
Socket Key, 9/64 Inch

Materials:

Cloths (E135)
Lockwire (E231)

Parts:

Preformed Packing
Retainers

Personnel Required:

Medium Helicopter Repairer
Inspector

References:

TM 55-1520-240-23P

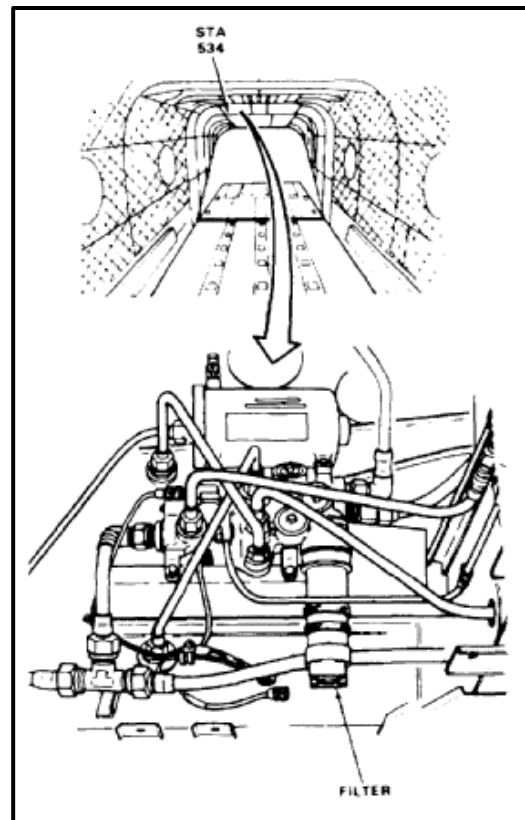

1. Install retainers (1) and packing (2) on indicator (3).
2. Position indicator (3) in filter (4). Install four screws (5). Torque screws to **35 inch-pounds** using diagonal sequence.
3. Lockwire screws (5) in pairs. Use lockwire (E231).
4. Connect connector (6) to indicator (3).

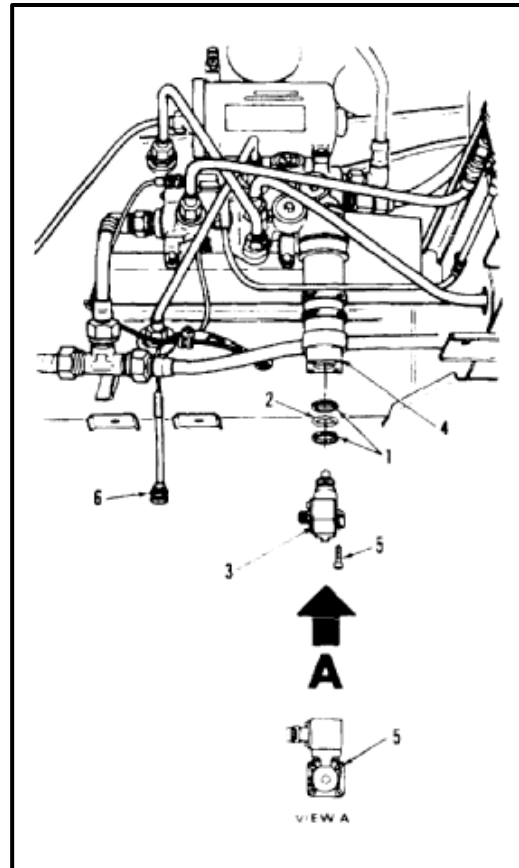
INSPECT**FOLLOW-ON MAINTENANCE:**

- Perform operational check (TM 55-1520-240-T).
- Service utility hydraulic reservoir (Task 1-59 or 1-62).
- Close cargo ramp (TM 55-1520-240-10).

END OF TASK

7-782

7-200 REMOVE UTILITY RETURN CONTROL MODULE FILTER CHECK VALVES**7-200****INITIAL SETUP****Applicable Configurations:**

All

Tools:

Aircraft Mechanic's Tool Kit, NSN 51 80-00-323-4692
Container, 2 Quart

Materials:

Cloths (E135)
Gloves (E186)

Personnel Required:

Medium Helicopter Repairer

Equipment Condition:

Battery Disconnected (Task 1-39)
Electrical Power Off
Hydraulic Power Off
Utility Hydraulic System Depressurized (Task 7-135.1)
Cargo Ramp Closed (TM 55-1520-240-10)

General Safety Instructions:**WARNING**

Hydraulic fluid (E199) is toxic. It can irritate skin and cause burns. Avoid inhaling. Use only with adequate ventilation. Avoid contact with skin, eyes, or clothing. In case of contact, immediately flush skin or eyes with water for at least **15 minutes**. Get medical attention for eyes.

WARNING

Hydraulic fluid ejected under pressure can cause injury to personnel. Hydraulic fluid sprayed into the air is a fire hazard.

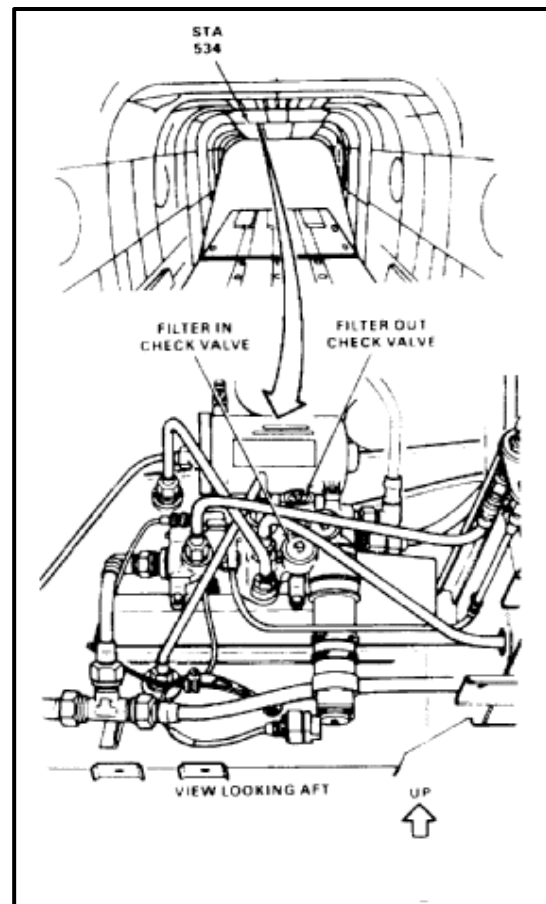

NOTE

Procedure is the same to remove the filter check valves. Filter check valve out is shown here.

1. Remove lockwire from valve (1).
2. Remove valve (1), two packings (2), and four retainers (3) from FLTR OUT CV port (4). Use container and cloths (E135) for spilled fluid. Use gloves (E186).

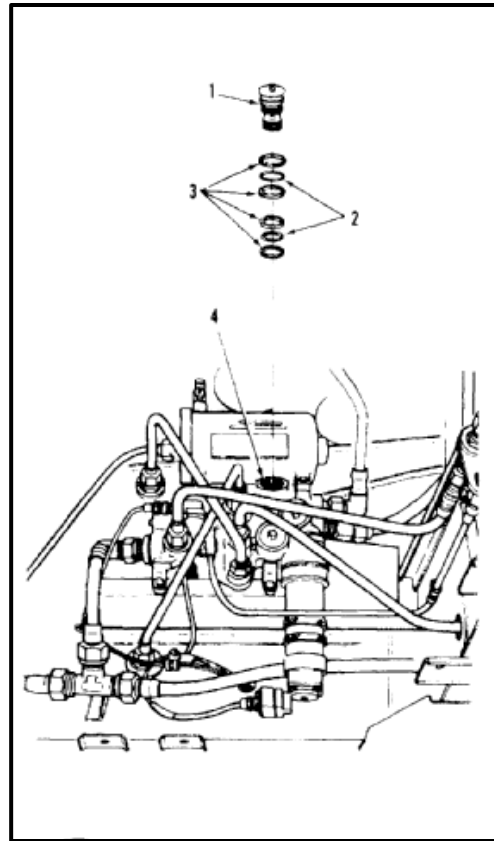
**FOLLOW-ON MAINTENANCE:**

None

END OF TASK

7-784

7-201 INSTALL UTILITY RETURN CONTROL MODULE FILTER CHECK VALVES

7-201

INITIAL SETUP**Applicable Configurations:**

All

Tools:

Aircraft Mechanic's Tool Kit, NSN 51 80-00-323-4692

Materials:

Lockwire (E231)

Parts:Preformed Packings
Retainers**Personnel Required:**Medium Helicopter Repairer
Inspector**References:**

TM 55-1520-240-23P

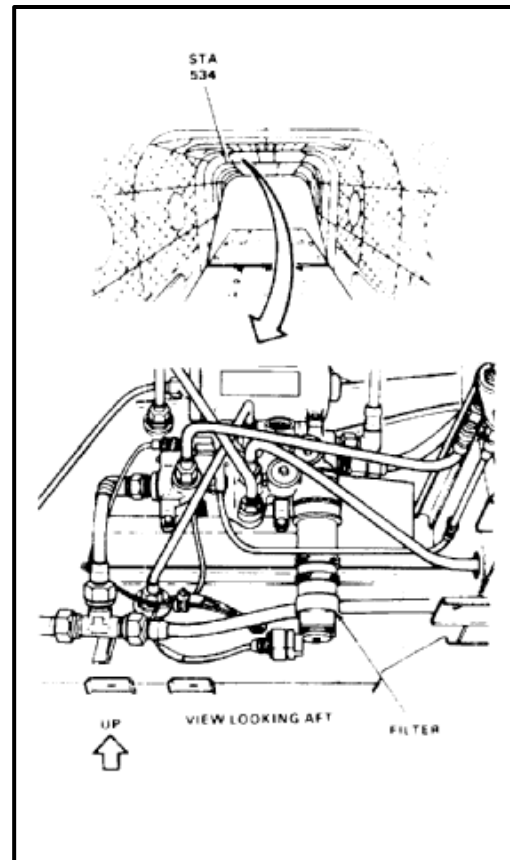

NOTE

Procedure is the same to install the filter check valves. Filter check valve out is shown here.

1. Install two packings (1) and four retainers (2) on valve (3).
2. Install valve (3) in FLTR OUT CV port (4) of module (5).
3. Lockwire valve (4) to FILTER RV bolt (6). Use lockwire (E231).

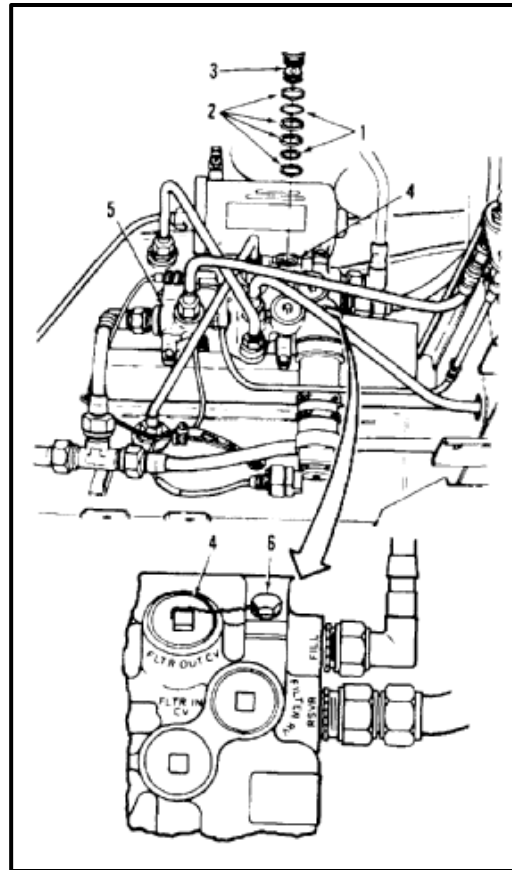
INSPECT**FOLLOW-ON MAINTENANCE:**

- Perform operational check (TM 55-1 520-240-T).
- Service utility hydraulic reservoir (Task 1-59 or 1-62).
- Close cargo ramp (TM 55-1520-240-10).

END OF TASK

7-786

INITIAL SETUP

Applicable Configurations:

All

Tools:

Aircraft Mechanic's Tool Kit, NSN 51 80-00-323-4692
Container, 2 Quart

Materials:

Cloths (E135)
Gloves (E186)

Personnel Required:

Medium Helicopter Repairer

Equipment Condition:

Battery Disconnected (Task 1-39)
Electrical Power Off
Hydraulic Power Off
Utility Hydraulic System Depressurized (Task 7-135.1)
Cargo Ramp Open (TM 55-1520-240-10)

General Safety Instructions:**WARNING**

Hydraulic fluid (E199) is toxic. It can irritate skin and cause burns. Avoid inhaling. Use only with adequate ventilation. Avoid contact with skin, eyes, or clothing. In case of contact, immediately flush skin or eyes with water for at least **15 minutes**. Get medical attention for eyes.

WARNING

Hydraulic fluid ejected under pressure can cause injury to personnel.
Hydraulic fluid sprayed into the air is a fire hazard.

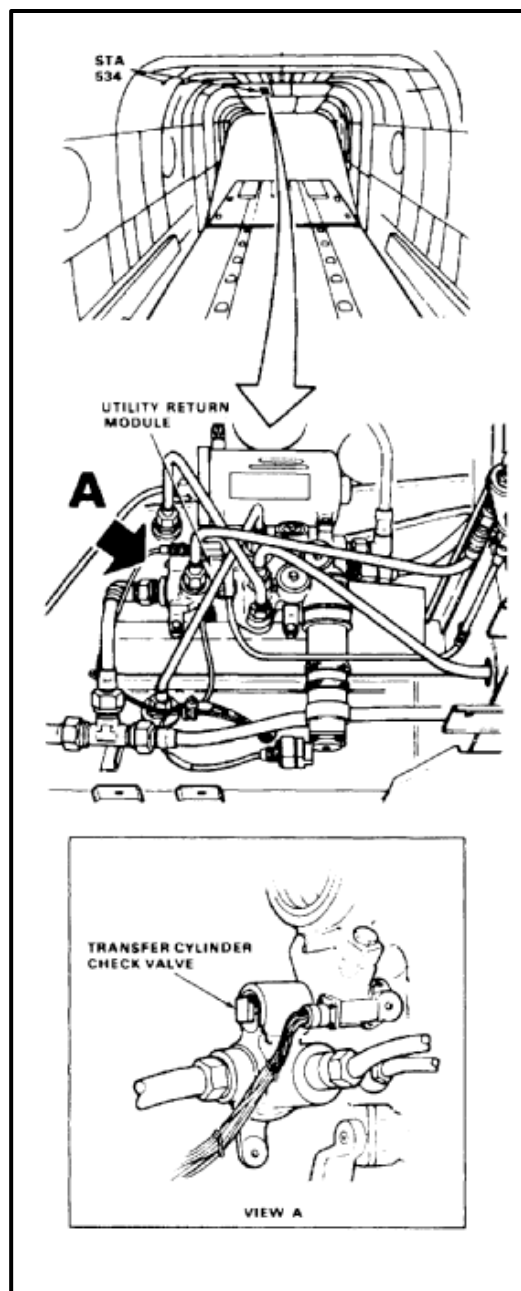

1. Remove lockwire from valve (1).
2. Remove valve (1), four retainers (2), and two packings (3) from XFR CYL CV port (4). Use container and cloths (E135) for spilled fluid. Use gloves (E186).

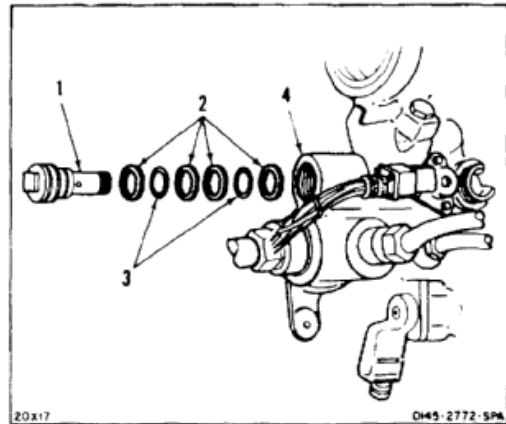
**FOLLOW-ON MAINTENANCE:**

None

END OF TASK

7-788

INITIAL SETUP

Applicable Configurations:

All

Tools:

Aircraft Mechanic's Tool Kit, NSN 51 80-00-323-4692

Materials:

Lockwire (E231)

Parts:

Preformed Packings
Retainers

Personnel Required:

Medium Helicopter Repairer
Inspector

References:

TM 55-1520-240-23P

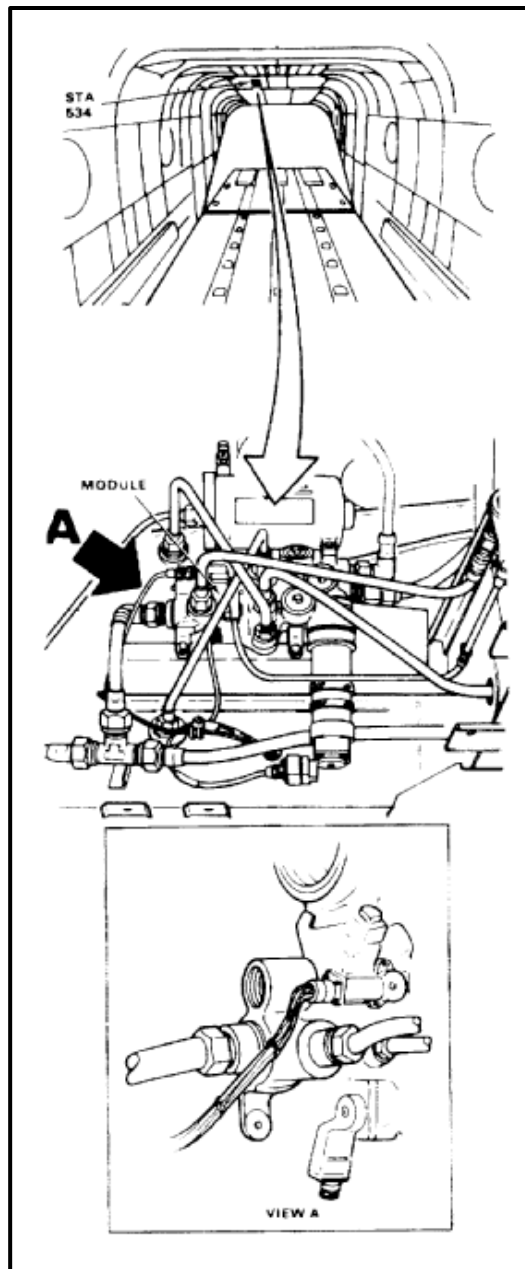

1. Install four retainers (1) and two packings (2) on valve (3).
2. Install valve (3) in XFR CYL CV port (4) of module (5).
3. Lockwire valve (3) to module (5). Use lockwire (E231).

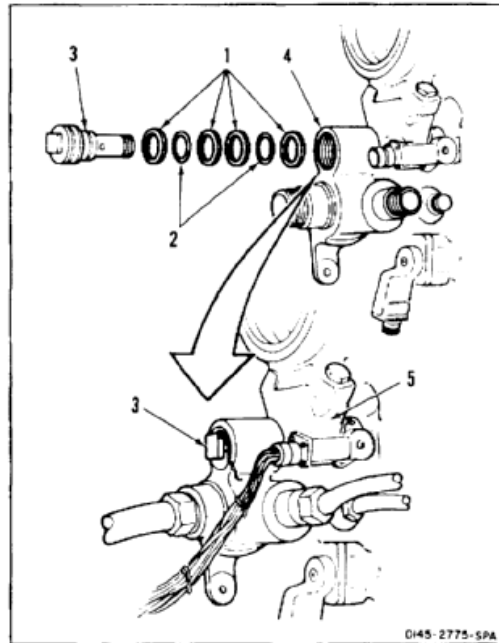
INSPECT**FOLLOW-ON MAINTENANCE:**

- Perform operational check (TM 55-1520-240-T).
- Service utility hydraulic reservoir (Task 1-59 or 1-62).
- Close cargo ramp (TM 55-1520-240-10).

END OF TASK

7-790

INITIAL SETUP

Applicable Configurations:

All

Tools:

Aircraft Mechanic's Tool Kit, NSN 51 80-00-323-4692
 Container, 2 Quart

Materials:

Cloths (E135)
 Gloves (E186)

Personnel Required:

Medium Helicopter Repairer

Equipment Condition:

Battery Disconnected (Task 1-39)
 Electrical Power Off
 Hydraulic Power Off
 Utility Hydraulic System Depressurized (Task 7-135.1)
 Cargo Ramp Open and Level (TM 55-1520-240-10)

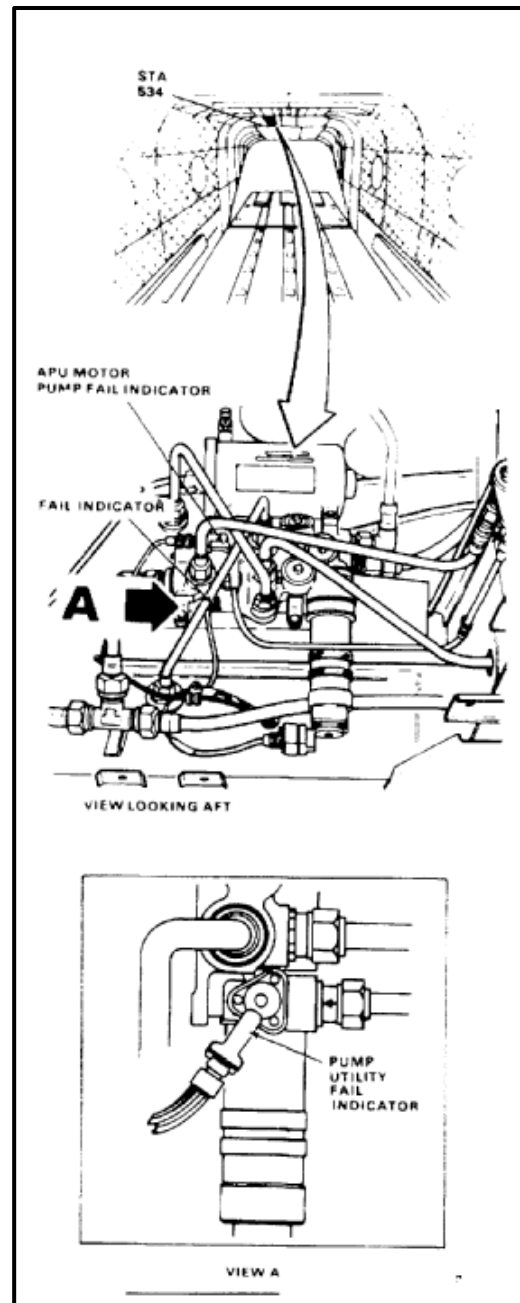

NOTE

There are two fail indicators on the module, APU motor pump, and utility pump. Utility pump fail indicator is shown here.

1. Disconnect connector (1) from indicator (2).
2. Remove lockwire and three screws (3).
3. Remove indicator (2), retainer (4), and two packings (5) from module (6). Use container and cloths (E135) for spilled fluid. Use gloves (E186).

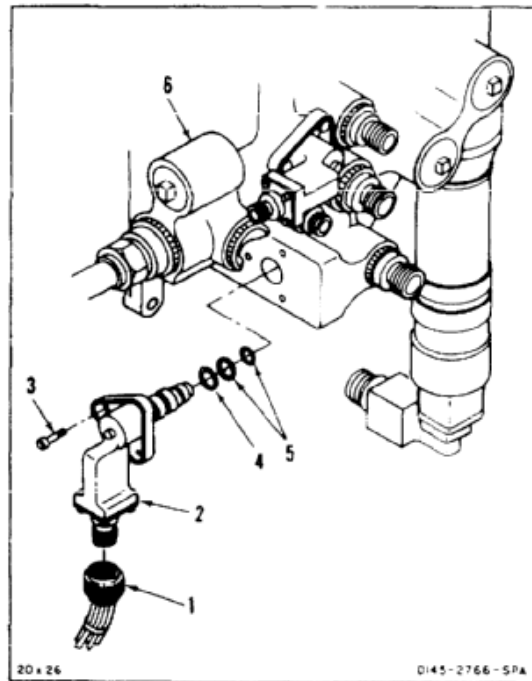
**FOLLOW-ON MAINTENANCE:**

None

END OF TASK

7-792

INITIAL SETUP

Applicable Configurations:

All

Tools:

Aircraft Mechanic's Tool Kit, NSN 5180-00-323-4692
 Torque Wrench, 5 to 50 Inch-Pounds
 Socket Key, 9/64 Inch

Materials:

Cloths (E135)
 Lockwire (E231)
 Gloves (E186)

Parts:

Preformed Packings
 Retainer

Personnel Required:

Medium Helicopter Repairer
 Inspector

References:

TM 55-1520-240-23P

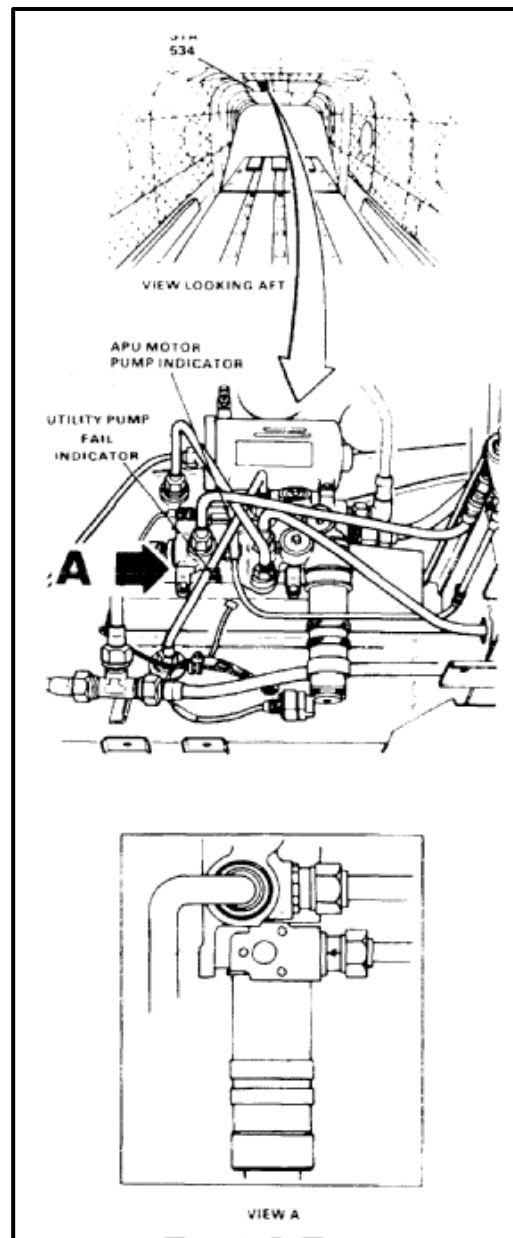

NOTE

There are two fail indicators on the module, APU motor pump and utility pump. Installation is same. Utility pump indicator is shown here.

1. Install retainer (1) and two packings (2) on indicator (3).
2. Install indicator (3) and three screws (4) in module (5). Use cloths (E135) for spilled fluid. Use gloves (E186).
3. Torque screws (4) to **35 inch-pounds**. Lockwire three screws (4). Use lockwire (E231).
4. Connect connector (6) to indicator (3).

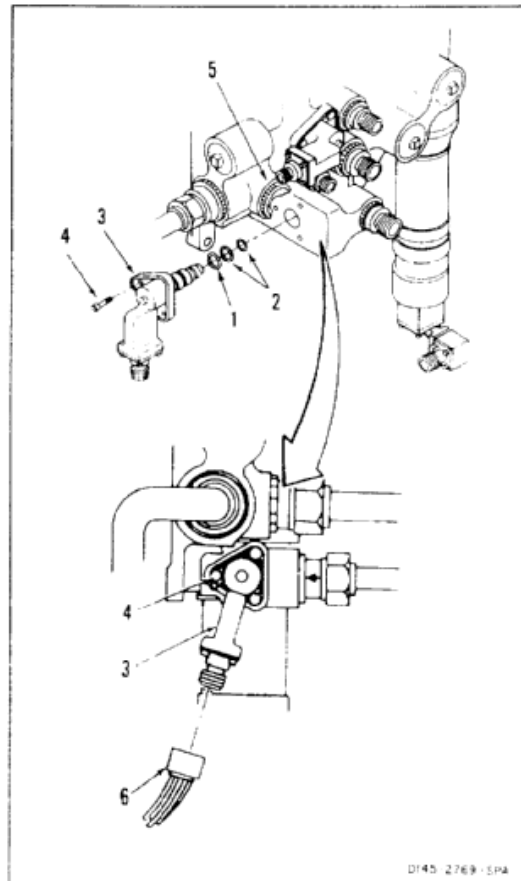
INSPECT**FOLLOW-ON MAINTENANCE:**

Perform operational check (TM 55-1520-240-T).
 Service utility hydraulic reservoir (Task 1-59 or 1-62).
 Close cargo ramp (TM 55-1520-240-10).

END OF TASK

7-794

7-206 REMOVE UTILITY RESERVOIR/COOLER RELIEF VALVE

7-206

INITIAL SETUP**Applicable Configurations:**

All

Tools:

Aircraft Mechanic's Tool Kit, NSN 5180-00-323-4692
 Container, 2 Quart

Materials:

Cloths (E135)

Personnel Required:

Medium Helicopter Repairer

Equipment Condition:

Battery Disconnected (Task 1-39)
 Electrical Power Off
 Hydraulic Power Off
 Utility Hydraulic System Depressurized (Task 7-135.1)
 Right Aft Pylon Access Door Open (Task 2-2)
 Temperature Switch Removed (Task 7-210)

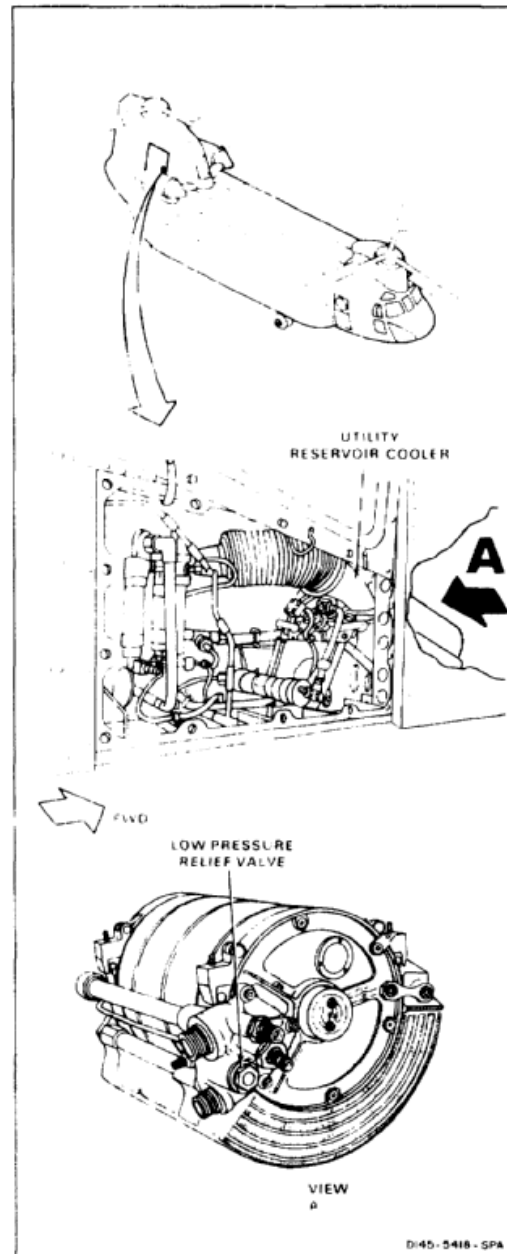

1. Loosen clamp (1) and disconnect duct (2) from reservoir/cooler (3).
2. Loosen clamp (4) and disconnect hose (5) from elbow (6).
3. Open valve (7) and drain fluid reservoir/cooler (3). Use container and cloths (E135) for spilled fluid.
4. Connect hose (5) to elbow (6). Tighten clamp (4).

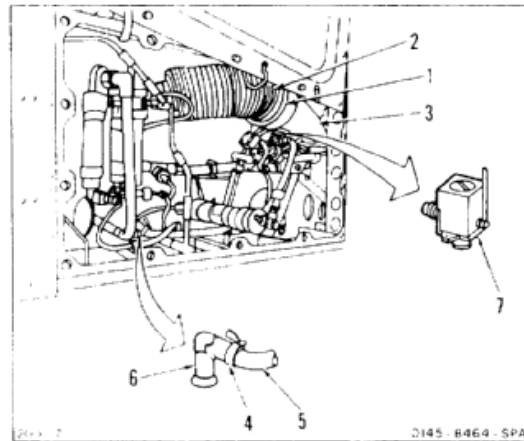

5. Remove lockwire from valve (8), switch (9), and bulb (10).
6. Remove valve (8), two packings (11), and retainers (12) from reservoir/cooler (3). Use cloths (E135) for spilled fluid.

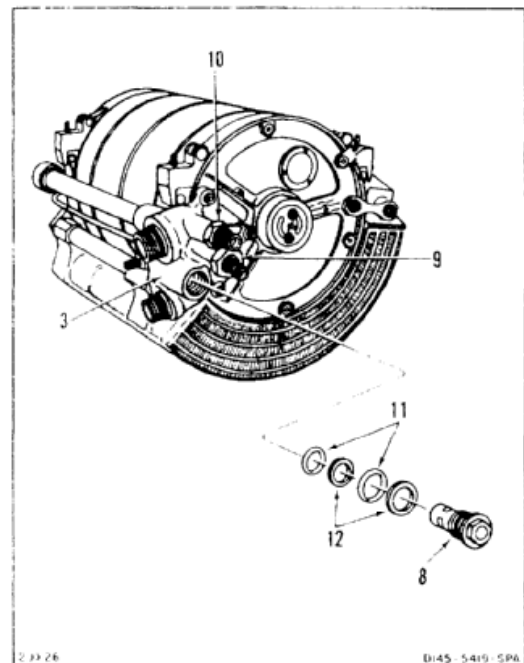
**FOLLOW-ON MAINTENANCE:**

None

END OF TASK

7-796

INITIAL SETUP

Applicable Configurations:

All

Tools:

Aircraft Mechanic's Tool Kit, NSN 5180-00-323-4692

Materials:

Lockwire (E231)

Parts:

Preformed Packings
Retainers

Personnel Required:

CH-47 Helicopter Repairer
Inspector

References:

TM 55-1520-240-23P

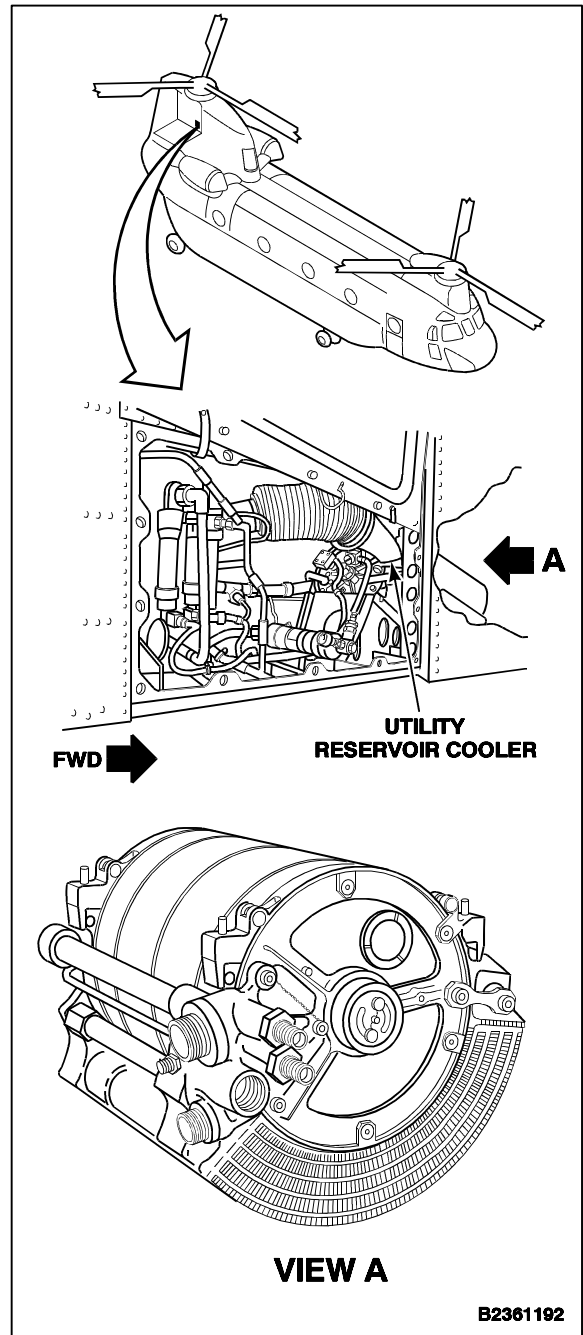

1. Install valve (1), retainer (2), packing (3), retainer (4), and packing (5) in port (6).
2. Lockwire valve (1), switch (7), and bulb (8). Use lockwire (E231).

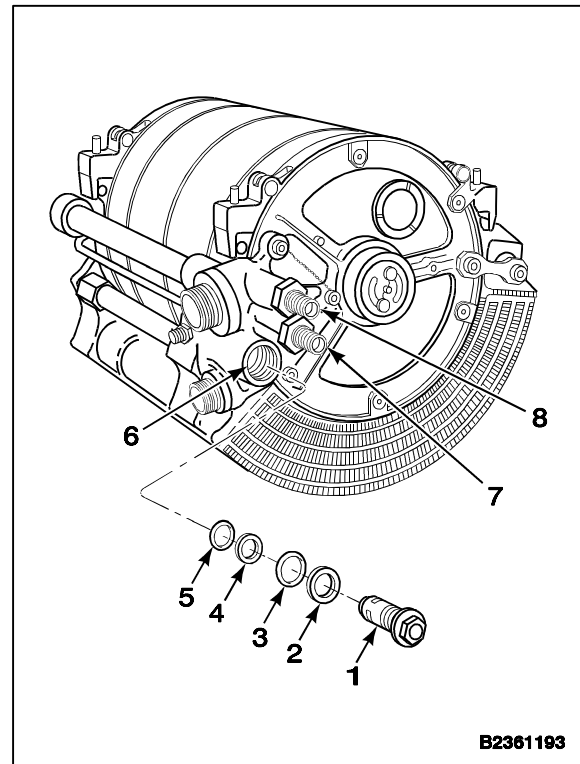
INSPECT**FOLLOW-ON MAINTENANCE:**

- Service reservoir (Task 1-59 or 1-62).
- Bleed utility hydraulic system (Task 7-335).
- Perform operational check (TM 55-1520-240-T).
- Close right aft pylon access door (Task 2-2).

END OF TASK

7-208 REMOVE UTILITY RESERVOIR/COOLER TEMPERATURE BULB

7-208

INITIAL SETUP**Applicable Configurations:**

All

Tools:

Aircraft Mechanic's Tool Kit, NSN 51 80-00-323-4692
Container, 2 Quart

Materials:

Cloths (E135)
Gloves (E184.1)
Paper Tags (E264)

Personnel Required:

Medium Helicopter Repairer

Equipment Condition:

Battery Disconnected (Task 1-39)
Electrical Power Off
Hydraulic Power Off
Utility Hydraulic System Depressurized (Task 7-135.1)
Right and Left Aft Pylon Access Door Open (Task 2-2)

General Safety Instructions:**WARNING**

Hydraulic fluid (E199) is toxic. It can irritate skin and cause burns. Avoid inhaling. Use only with adequate ventilation. Avoid contact with skin, eyes, or clothing. In case of contact, immediately flush skin or eyes with water for at least **15 minutes**. Get medical attention for eyes.

WARNING

Hydraulic fluid ejected under pressure can cause injury to personnel. Hydraulic fluid sprayed into the air is a fire hazard.

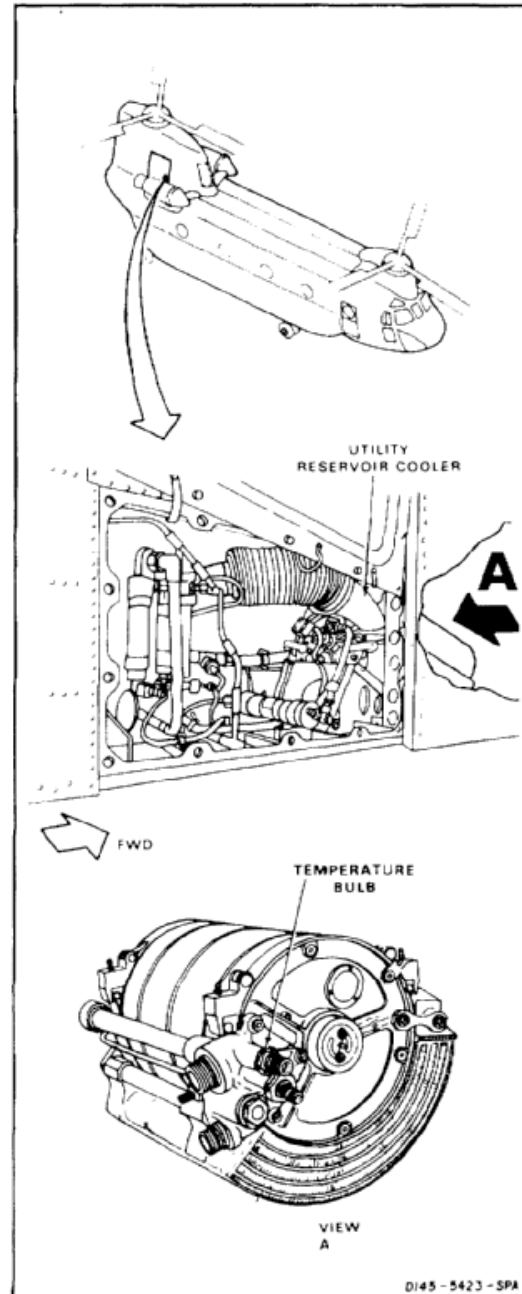

1. Loosen clamp (1) and disconnect duct (2) from reservoir/cooler (3).
2. Loosen clamp (4) and disconnect hose (5) from elbow.
3. Open valve (7) and drain fluid reservoir/cooler (3). Use container and cloths (E135) for spilled fluid. Wear gloves (E184.1).
4. Connect hose (5) to elbow (6). Tighten clamp (4).

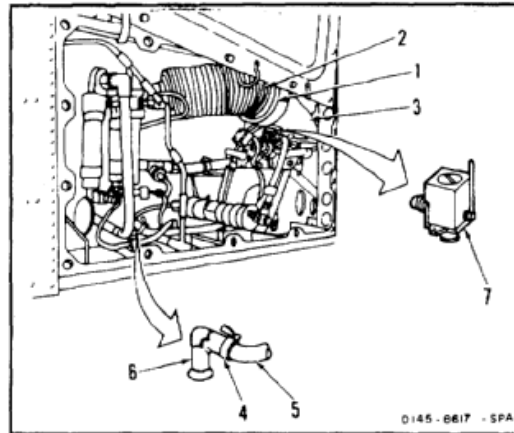

5. Tag and disconnect cable plug (11.1). Use paper tag (E264).
6. Remove lockwire from bulb (8), switch (9), and valve (10).
7. Remove bulb (8) and packing (11) from reservoir/cooler (3). Use cloths (E135) for spilled fluid. Wear gloves (E184.1).

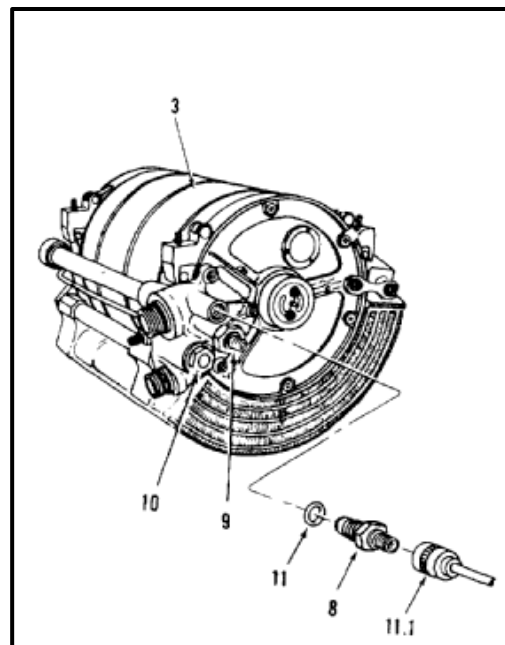
**FOLLOW-ON MAINTENANCE:**

None

END OF TASK

7-800

INITIAL SETUP

Applicable Configurations:

All

Tools:

Aircraft Mechanic's Tool Kit, NSN 51 80-00-323-4692

Materials:

Lockwire (E231)

Personnel Required:

Medium Helicopter Repairer
Inspector

References:

TM 55-1520-240-23P

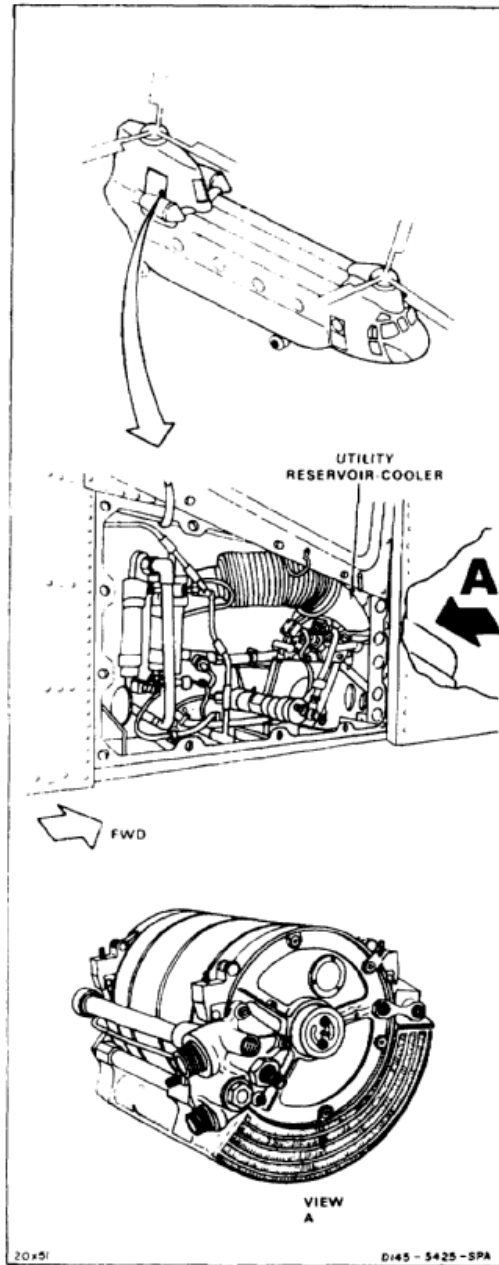

1. Install bulb (1) and packing (2) in port (3).
2. Lockwire bulb (1), switch (4), and valve (5). Use lockwire (E231).
3. Connect electrical connector (6) to bulb (1).

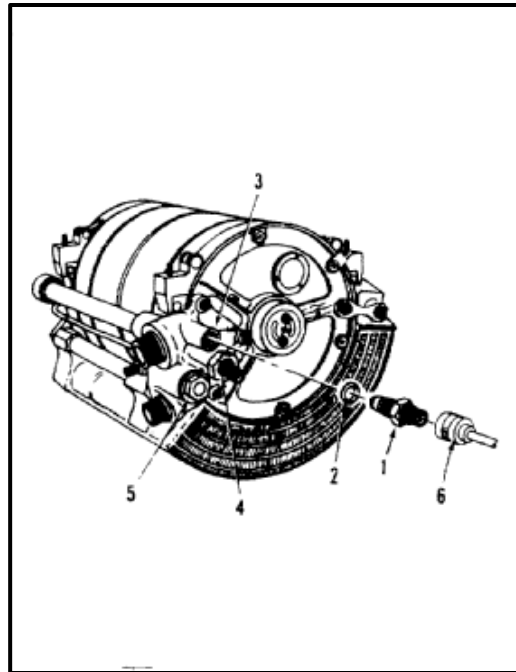
INSPECT***FOLLOW-ON MAINTENANCE:***

- Service reservoir (Task 1-59 or 1-62).
- Bleed utility hydraulic system (Task 7-335).
- Perform operational check (TM 55-1520-240-T).
- Close right and left aft pylon access door (Task 2-2).

END OF TASK

7-802

INITIAL SETUP

Applicable Configurations:

All

Tools:

Aircraft Mechanic's Tool Kit, NSN 5180-00-323-4692
Container, 2 Quart

Materials:

Cloths (E135)
Paper Tags (E264)

Personnel Required:

Medium Helicopter Repairer

Equipment Condition:

Battery Disconnected (Task 1-39)
Electrical Power Off
Hydraulic Power Off
Utility Hydraulic System Depressurized (Task 7-135.1)
Right and Left Aft Pylon Access Door Open (Task 2-2)

General Safety Instructions:**WARNING**

Hydraulic fluid (E199) is toxic. It can irritate skin and cause burns. Avoid inhaling. Use only with adequate ventilation. Avoid contact with skin, eyes, or clothing. In case of contact, immediately flush skin or eyes with water for at least **15 minutes**. Get medical attention for eyes.

WARNING

Hydraulic fluid ejected under pressure can cause injury to personnel.
Hydraulic fluid sprayed into the air is a fire hazard.

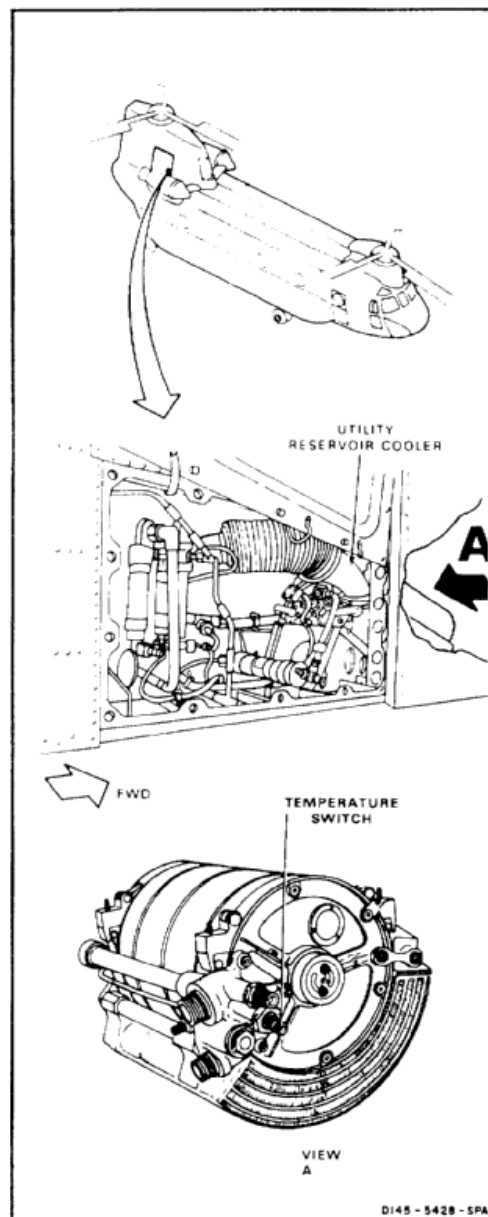

1. Loosen clamp (1) and disconnect duct (2) from reservoir/cooler (3).
2. Loosen clamp (4) and disconnect hose (5) from elbow (6).
3. Open valve (7) and drain fluid reservoir/cooler (3). Use container and cloths (E135) for spilled fluid. Wear gloves (E184.1).
4. Connect hose (5) to elbow (6). Tighten clamp (4).

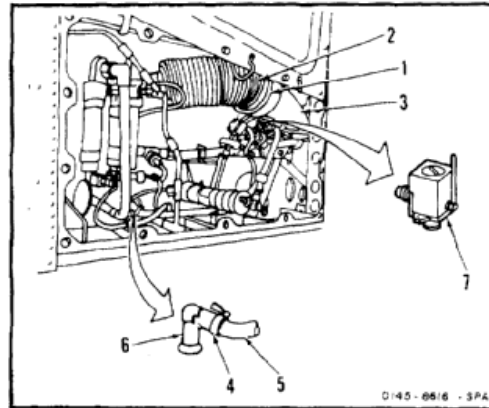

5. Tag and disconnect cable plug (11.1). Use paper tag (E264).
6. Remove lockwire from switch (8), valve (9), and bulb (10).
7. Remove switch (8) and packing (11) from reservoir/cooler (3). Use cloths (E135) for spilled fluid. Wear gloves (E184.1).

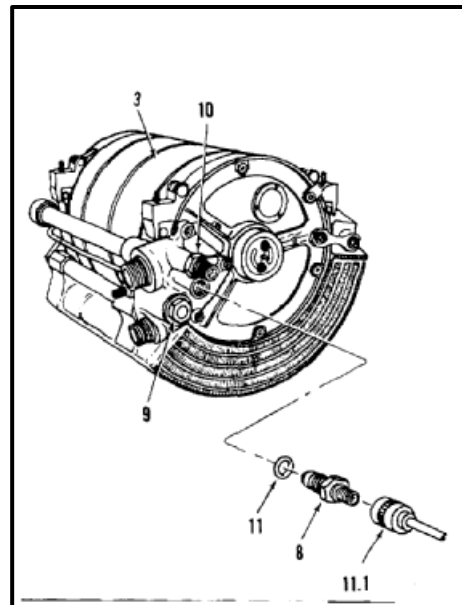
**FOLLOW-ON MAINTENANCE:**

None

END OF TASK

7-804

7-211 INSTALL UTILITY RESERVOIR/COOLER TEMPERATURE SWITCH

7-211

INITIAL SETUP

Applicable Configurations:

All

Tools:

Aircraft Mechanic's Tool Kit, NSN 51 80-00-323-4692

Materials:

Lockwire (E231)

Parts:

Preformed Packing

Personnel Required:

Medium Helicopter Repairer
Inspector

References:

TM 55-1520-240-23P

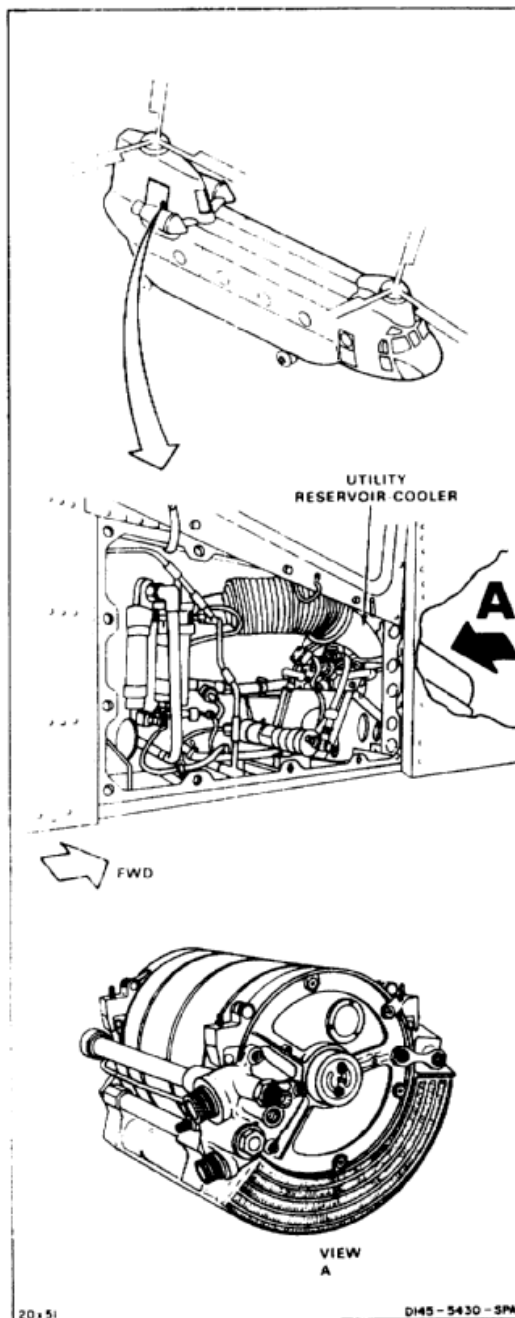

1. Install switch (1) and packing (2) in port (3).
2. Lockwire switch (1), valve (4), and bulb (5). Use lockwire (E231).
3. Connect electrical connector (6) to switch (1).

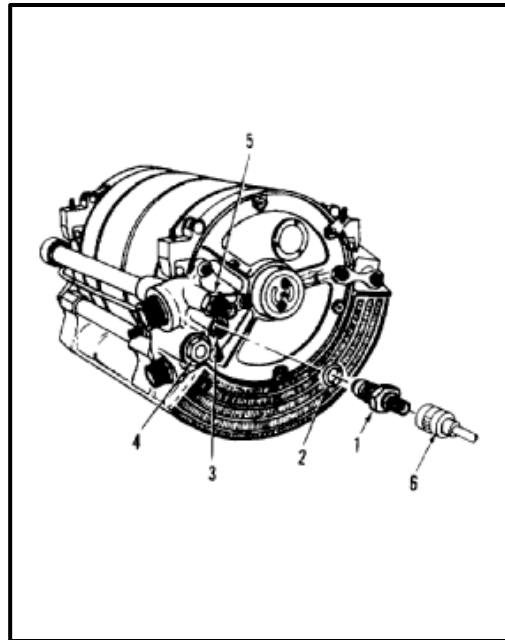
INSPECT***FOLLOW-ON MAINTENANCE:***

- Service reservoir (Task 1-59 or 1-62).
- Bleed utility hydraulic system (Task 7-335).
- Perform operational check (TM 55-1520-240-T).
- Close left and right aft pylon access door (Task 2-2).

END OF TASK

INITIAL SETUP

Applicable Configurations:

All

Tools:

Aircraft Mechanic's Tool Kit, NSN 5180-00-323-4692
 Container, 2 Quart
 Open-End Wrench, 1-1/4 Inch
 Open-End Wrench, 1-1/2 Inch

Materials:

Cloths (E135)
 Paper Tags (E264)
 Gloves (E186)

Personnel Required:

Medium Helicopter Repairer

Equipment Condition:

Battery Disconnected (Task 1-39)
 Electrical Power Off
 Hydraulic Power Off
 Utility Hydraulic System Depressurized (Task 7-135.1)
 Left or Right Aft Pylon Access Door Open (Task 2-2)

General Safety Instructions:**WARNING**

Hydraulic fluid (E199) is toxic. It can irritate skin and cause burns. Avoid inhaling. Use only with adequate ventilation. Avoid contact with skin, eyes, or clothing. In case of contact, immediately flush skin or eyes with water for at least **15 minutes**. Get medical attention for eyes.

WARNING

Hydraulic fluid ejected under pressure can cause injury to personnel. Hydraulic fluid sprayed into the air is a fire hazard.

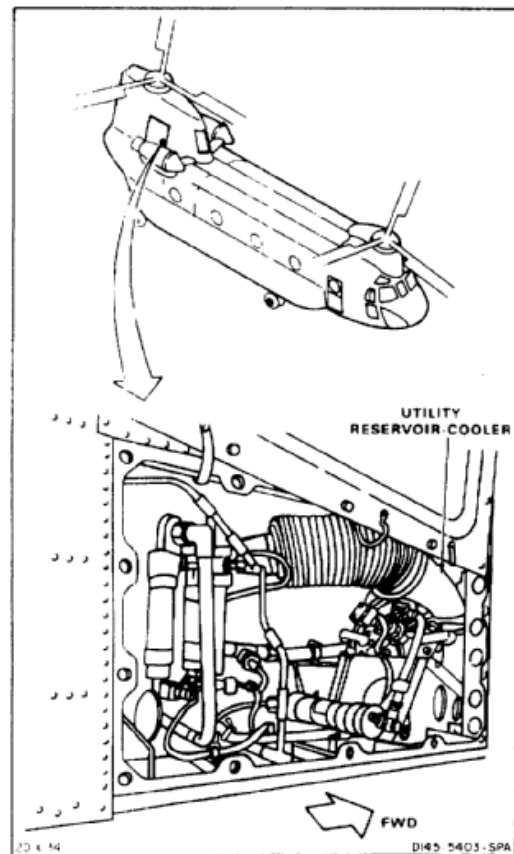

1. Loosen clamp (1) and disconnect duct (2) from reservoir/cooler (3).
2. Loosen clamp (4) and disconnect hose (5) from elbow (6).
3. Open valve (7) and drain fluid reservoir/cooler (3). Use container and cloths (E135) for spilled fluid. Use gloves (E186).
4. Connect hose (5) to elbow (6). Tighten clamp (4).

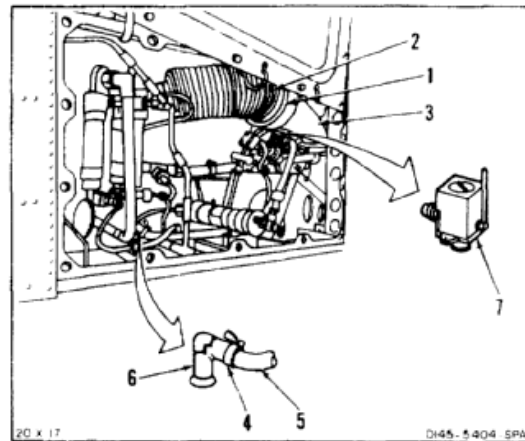

5. Loosen clamps (8) and disconnect hose (5) from valve (7).
6. Tag and disconnect three tubes (9).
7. Tag and disconnect three cable plugs (10).
8. Remove four nuts (11) and washers (12).
9. Remove reservoir/cooler (3).

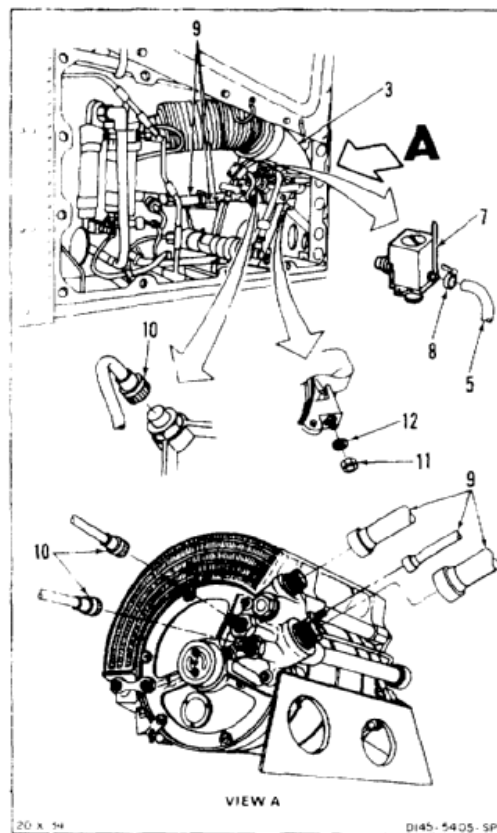

7-212 REMOVE UTILITY RESERVOIR/COOLER (Continued)

7-212

10. If reservoir/cooler (3) is being replaced do the following:
 - a. Remove lockwire from two screws (13).
 - b. Remove two screws (13), valve (7) and packing (14). Use cloths (E135) for spilled fluid. Use gloves (E186).
 - c. Remove lockwire from valve (15), switch (16), and bulb (17).
 - d. Remove valve (15), two packings (18), and two retainers (19). Use cloths (E135) for spilled fluid. Use gloves (E186).
 - e. Remove switch (16) and packing (20). Use cloths (E135) for spilled fluid. Use gloves (E186).
 - f. Remove bulb (17) and packing (21). Use cloths (E135) for spilled fluid. Use gloves (E186).

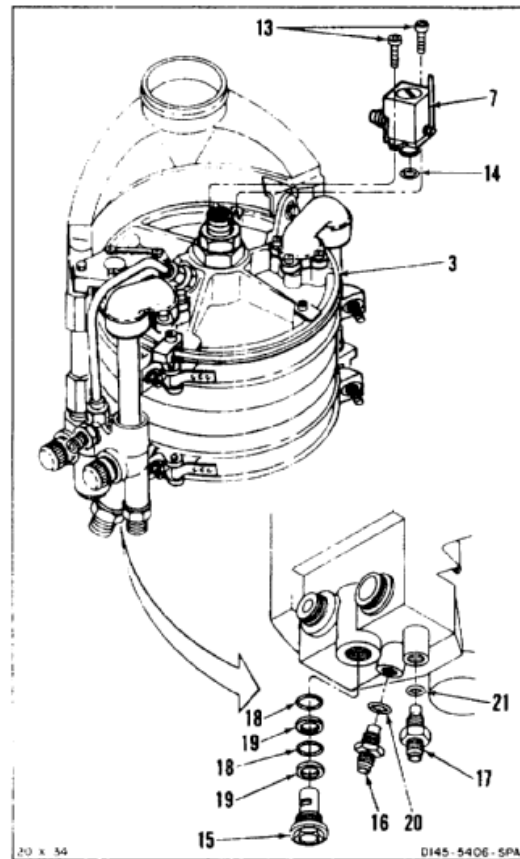
**FOLLOW-ON MAINTENANCE:**

None

END OF TASK

INITIAL SETUP

Applicable Configurations:

All

Tools:

Aircraft Mechanic's Tool Kit, NSN 5180-00-323-4692

Materials:Cloths (E135)
Gloves (E186)**Personnel Required:**

Medium Helicopter Repairer

Equipment Condition:

Off Helicopter Task

General Safety Instructions:**WARNING**

Hydraulic fluid (E199) is toxic. It can irritate skin and cause burns. Avoid inhaling. Use only with adequate ventilation. Avoid contact with skin, eyes, or clothing. In case of contact, immediately flush skin or eyes with water for at least **15 minutes**. Get medical attention for eyes.

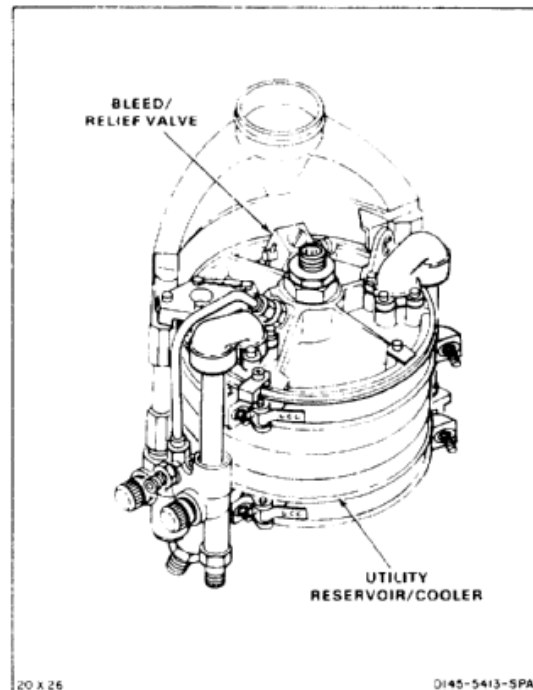

7-213 REMOVE UTILITY RESERVOIR/COOLER BLEED/RELIEF VALVE (Continued)

7-213

1. Remove lockwire from two screws (1).
2. Remove two screws (1) from valve (2).
3. Remove valve (2) and packing (3). Use cloths (E135) for spilled fluid. Use gloves (E186).

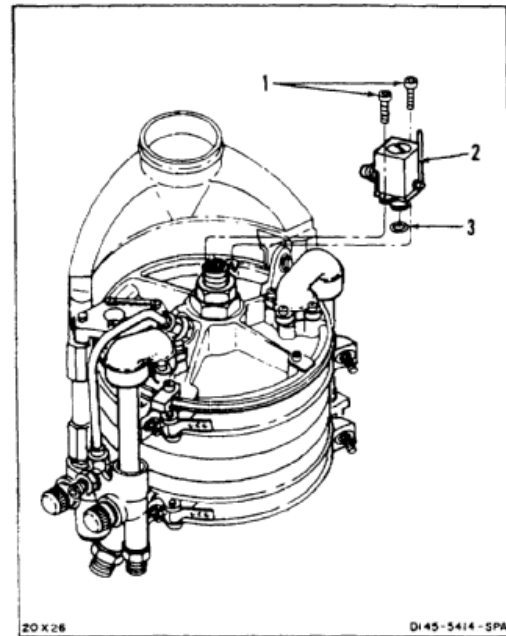
**FOLLOW-ON MAINTENANCE:**

None

END OF TASK

INITIAL SETUP

Applicable Configurations:

All

Tools:

Hydraulic Repairer's Tool Kit, NSN 5180-00-323-4891
 Deep Well Socket, 7/16 Inch
 Technical Inspection Tool Kit, NSN 5180-00-323-5114
 Outside Micrometer Caliper, 1 to 2 Inch

Materials:

Cloths (E120)
 Gloves (E186)

Personnel Required:

Aircraft Pneudraulics Repairer
 Inspector

References:

TM 1-1520-253-23
 Task 7-1.1

Equipment Condition:

Off Helicopter Task

General Safety Instructions:**WARNING**

Hydraulic fluid (E199) is toxic. It can irritate skin and cause burns. Avoid inhaling. Use only with adequate ventilation. Avoid contact with skin, eyes, or clothing. In case of contact, immediately flush skin or eyes with water for at least **15 minutes**. Get medical attention for eyes.

NOTE

General inspection criteria (Task 7-1.1) for obvious damage applies unless otherwise stated.

Inspection steps cover parts that are subject to wear.

1. Remove tube (1) between reservoir (12) and manifold (3). Use gloves (E186).
 - 1.1. Check tube (1) for dents and scratches. Dents shall not be deeper than **0.050 inch**. Scratches shall not be deeper than **0.004 inch**.
2. Remove lockwire, three screws (4), three washers (5), and manifold (3) with supply tube (6) from reservoir (2).

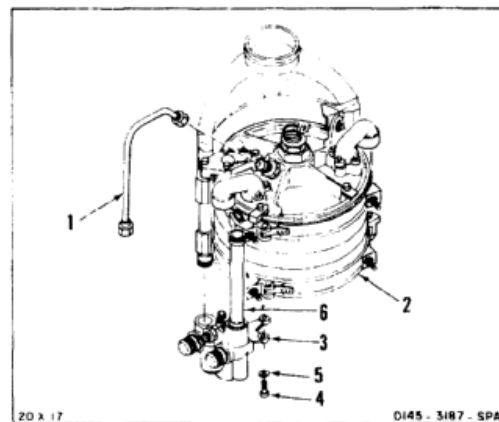
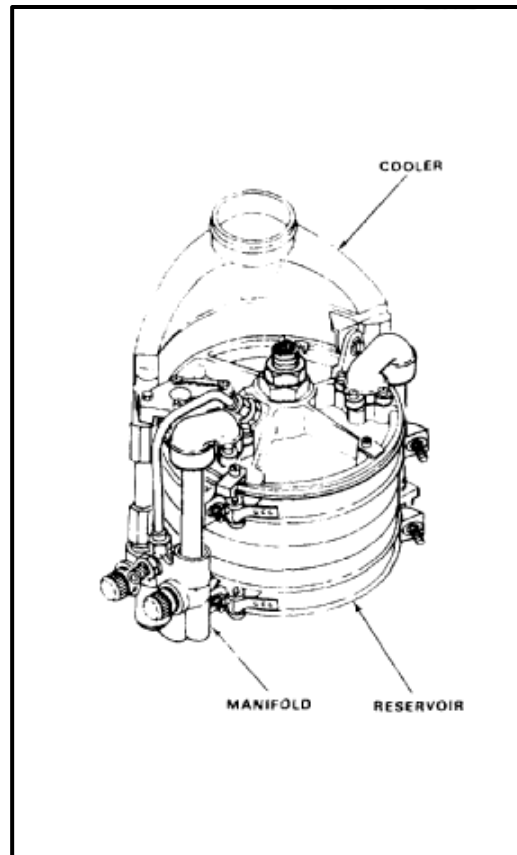

3. Remove nut (7), and elbow (8) from manifold (3).
4. Remove cotter pin (9), pin (10), and supply tube (6) from manifold (3).
5. Remove two packings (11) from tube (6).
- 5.1. Measure outside diameter of ends of tube (6). Diameter shall not be less than **1.13 inches**. Ends shall not be out of round more than **0.003 inch**.
- 5.2. Check tube (6) for dents and scratches. Dents shall not be deeper than **0.180 inch**. Scratches shall not be deeper than **0.010 inch**.

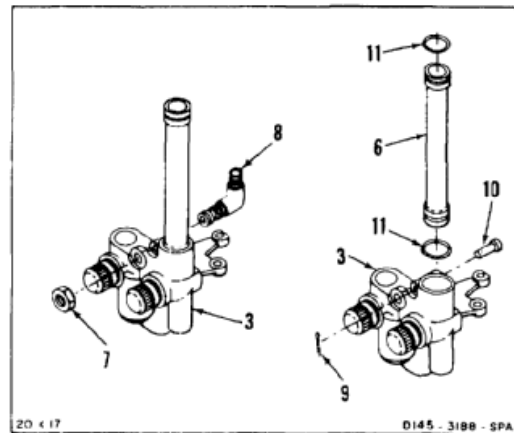

6. Remove lockwire, six screws (12), two joints (13), and two transfer tubes (14) from reservoir (2).
7. Remove two packings (15) from each tube (14).

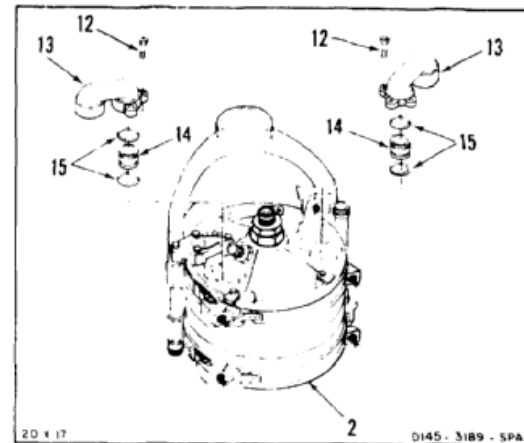

8. Remove nut (16), three washers (17), and screw (18) from reservoir (2) and cooler (19).
9. Remove lockwire, three screws (20), and three washers (21) from bracket (22).
10. Remove two screws (23), two washers (24), and link (25).
11. Remove nipple (26) from reservoir (2).
12. Remove packing (27) from nipple (26).
13. Remove cooler (19) from reservoir (2).

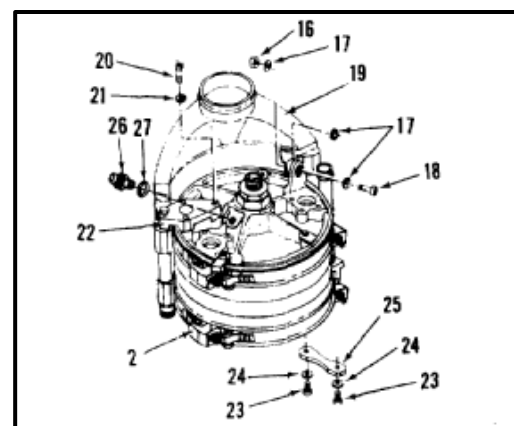

14. Remove cotter pin (28), pin (29), and return tube (30) from cooler (19). Use **7/16 inch** deep well socket.
15. Remove two packings (31) from tube (30). Inspect tube. (Refer to steps 5.1 and 5.2.)
16. Remove packing (32) from cooler (19).
17. Drain fluid from cooler (19). Use container for fluid. Use cloths (E120) to clean up spills.
18. Remove bolt (33) and bracket (22) from cooler (19).
- 18.1. Check mounting flanges (33.1 and 31.2) of cooler (19). Flanges shall not be bent.
- 18.2. Check welds on cooler (19) for cracks. There shall be no cracks. If a crack is suspected, refer to TM 1-1520-253-23.
- 18.3. Check fins (33.3) at bottom of cooler (19). Straighten bent fins.

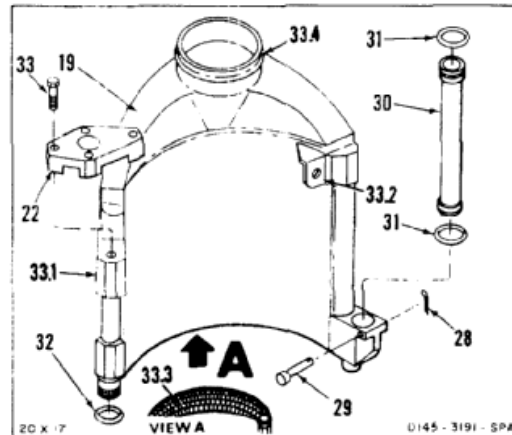

Heat will damage cooler.

- 18.4. Check neck (33.4) of cooler (19) for cracks and distortion. There shall be no cracks. Smooth distorted neck back to original shape. Do not apply heat. If a crack is suspected, refer to TM 1-1520-253-23.
- 18.5. Check strap mounts (34 and 35). There shall be no cracks or kinks. There shall be no broken welds. If a crack is suspected, refer to TM 1-1520-253-23.
19. If strap mount (34 or 35) is damaged, remove as follows:
 - a. Loosen one side of strap mount (34 or 35) enough to clear timing clamp (36).
 - b. Lift strap mount (34 or 35) to clear timing clamp (36). Remove strap mount from reservoir (2).
20. Check reservoir (2) for condition. There shall be no cracks or dents. If a crack is suspected, refer to TM 1-1520-253-23.

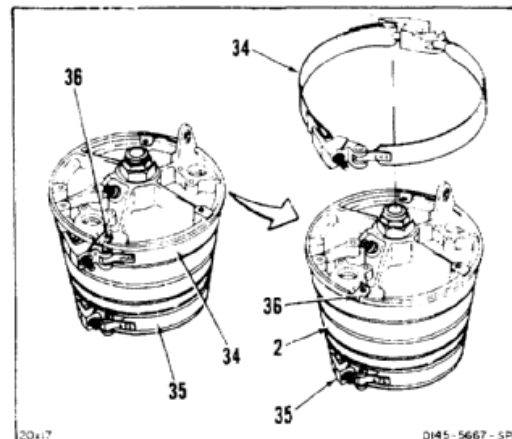

FOLLOW-ON MAINTENANCE:

None

END OF TASK

INITIAL SETUP

Applicable Configurations:

All

Tools:

Hydraulic Repairer's Tool Kit, NSN 5180-00-323-4891
 Torque Wrench, 30 to 150 Inch-Pounds
 Deep Socket, 7/16 Inch

Materials:

Lockwire (E231)

Parts:

Cotter Pins
 Preformed Packings

Personnel Required;

Aircraft Pneudraulics Repairer
 Inspector

References:

TM 55-1520-240-23P

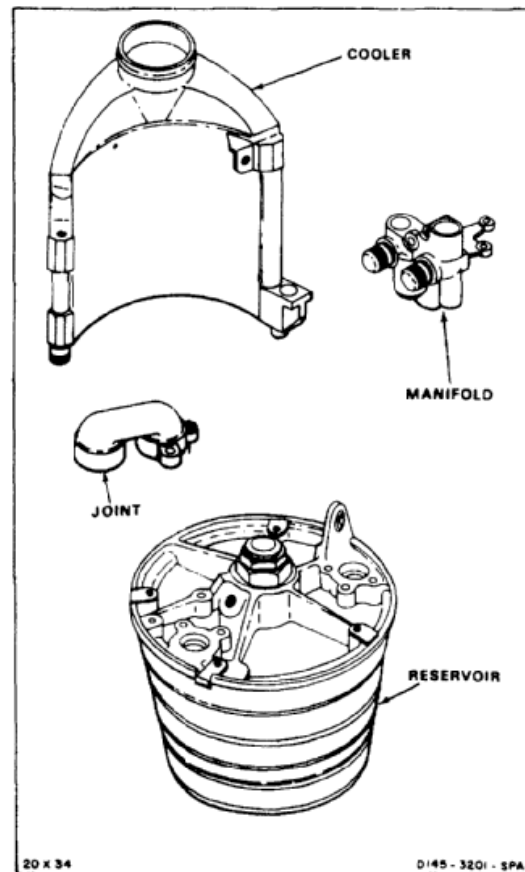

1. If strap mount (1 or 2) was removed from reservoir (3). Install as follows:
 - a. Slide strap mounts (1 or 2) over timing clamp (3) and onto reservoir (4).
 - b. Align notch in strap mount (1 and 2) with timing clamp (3).



Improper torque will crack clamps.

- c. Use deep socket to alternately tighten nuts on each side of strap mount (1 or 2). Torque strap mount nuts to **50 to 60 inch-pounds**.
2. Measure length of thread extending through the nuts on each side of strap mount (1 or 2). Length shall be **0.75 to 0.95 inch**.
3. Install packing (5) on nipple (6).
4. Install nipple (6) in reservoir (4).
5. Install packing (7) on cooler (8).
6. Install two packings (9) on short return tube (10).
7. Install short return tube (10), pin (11), and cotter pin (12) in cooler (8).

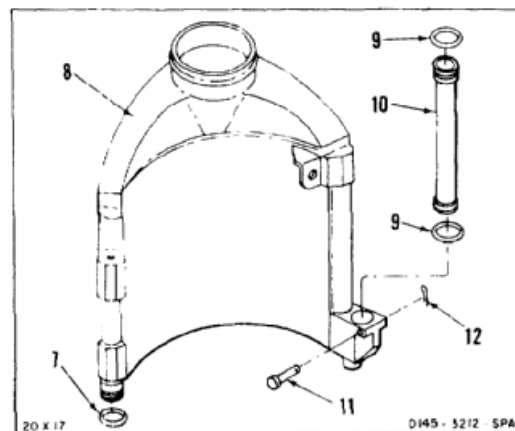
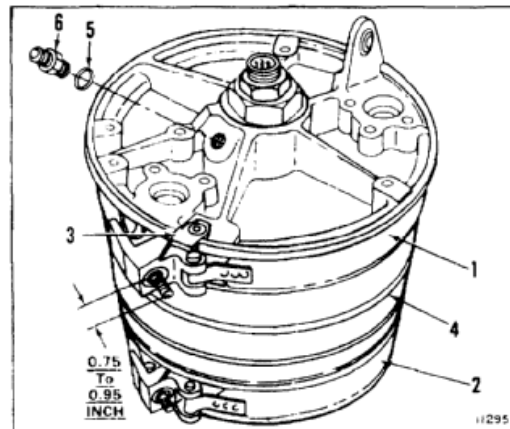

8. Position reservoir (4) on cooler (8).
9. Install link (13), two washers (14), and two screws (15) in reservoir (4) and cooler (8).
10. Install screw (16), three washers (17) and nut (18) in reservoir (4) and cooler (8).
11. Position bracket (19) on reservoir (4) and cooler (8). Install bolt (20).
12. Install three screws (21) in bracket (19) and reservoir (4). Torque bolt (20) to **30 inch-pounds**. Torque screws (21) to **55 inch-pounds**.
13. Lockwire screws (21). Use lockwire (E231).

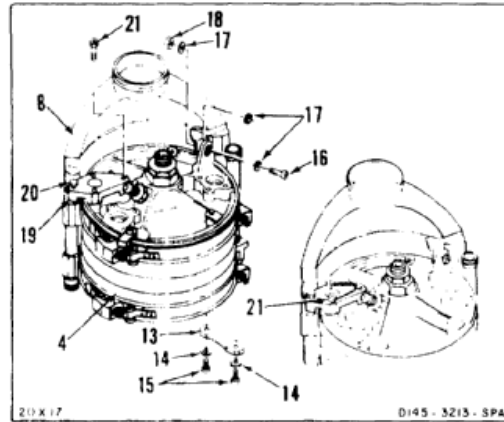

14. Install two packings (22), supply tube (23), pin (24), and cotter pin (25) in manifold (26).
15. Install elbow (27), and nut (28) in manifold (26).

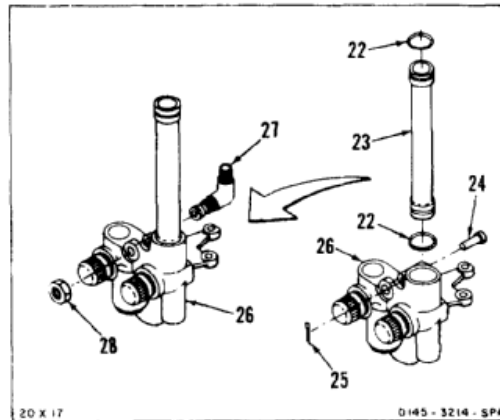

16. Install manifold (26), three screws (29), and three washers (38) on reservoir (4). Torque screws to **30 inch-pounds**.
17. Lockwire screws (29). Use lockwire (E231).
18. Install tube (31) between reservoir (4) and manifold (26).

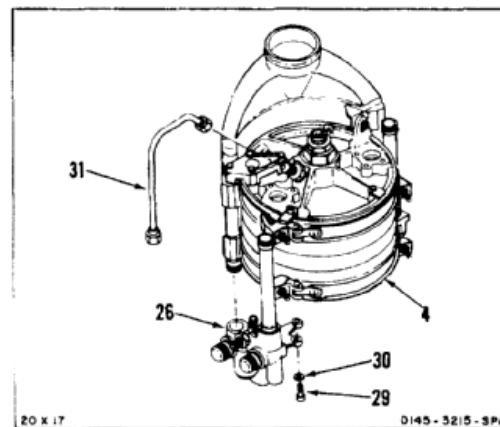

19. Install two packings (32) on each transfer tube (33).
20. Install two transfer tubes (33) in cover (34).
21. Position one joint (35) between cover (34) and supply tube (23). Install three screws (36).
22. Position other joint (35) between cover (34) and cooler return tube (10). Install three screws (36).
23. Torque six screws (36) to **20 inch-pounds**. Lockwire screws (36). Use lockwire (E231).

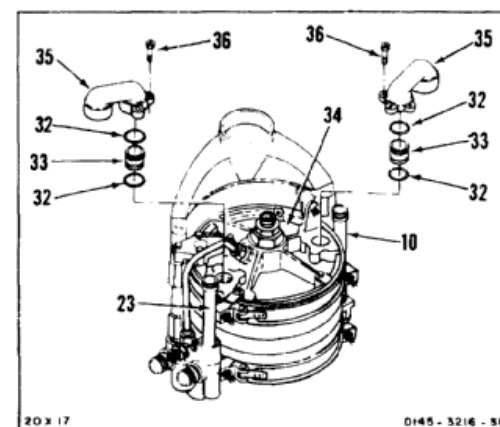

FOLLOW-ON MAINTENANCE:

Test utility reservoir/cooler (Task 7-217).

END OF TASK

7-216 INSTALL UTILITY RESERVOIR/COOLER BLEED/RELIEF VALVE

7-216

INITIAL SETUP**Applicable Configurations:**

All

Tools:

Aircraft Mechanic's Tool Kit, NSN 51 80-00-323-4692

Materials:

Lockwire (E231)

Parts:

Preformed Packing

Personnel Required:Medium Helicopter Repairer
Inspector**References:**

TM 55-1520-240-23

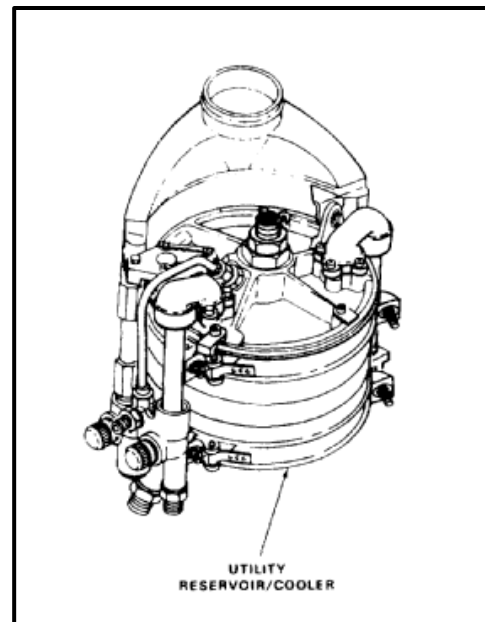

1. Install packing (1) and valve (2) in port (3).
2. Install two screws (4) in valve (2).
3. Lockwire two screws (4). Use lockwire (E231).

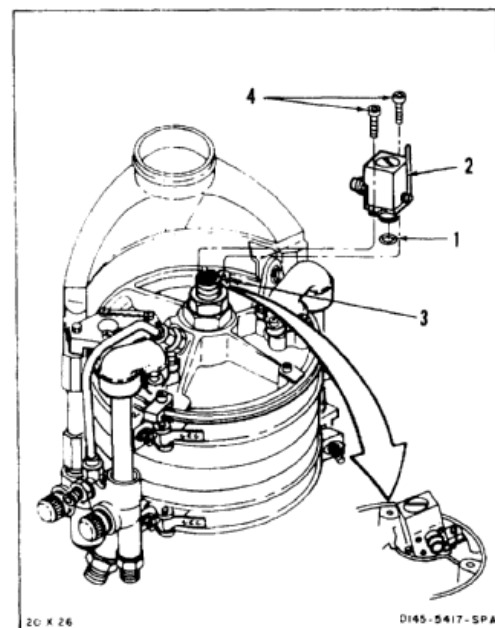
INSPECT**FOLLOW-ON MAINTENANCE:**

None

END OF TASK

INITIAL SETUP

Applicable Configurations:

All

Tools:

- Hydraulic Repairer's Tool Kit, NSN 5180-00-323-4891
- Signal Generator (Capable of 5 Volts, 10 ma at 450 Hz)
- Hydraulic Test Stand (0 to 4500 psi)
- Hydraulic Hand Pump
- Torque Wrench, 5 to 50 Inch-Pounds
- Container, 2 Quart
- Digital Voltmeter
- Milliammeter
- Resistor, 100,000 Ohms
- Shutoff Valve (3)
- Gage, 0 to 200 psi
- Bleed Relief Valve, 145HS211-1
- Relief Valve, 145HS207-1
- Temperature Bulb, 1122153
- Thermal Switch, A15HS015-2
- Flexible Hose, 1/4 Inch, 0 to 4500 psi
- Flexible Hose, 3/4 Inch OD, 0 to 150 psi
- Flexible Hose, 1 Inch OD, 0 to 150 psi

Materials:

- Cloths (E120)
- Lockwire (E231)
- Marking Pencil (E271)
- Gloves (E186)

Parts:

- Packings

Personnel Required:

- Aircraft Electrician
- Aircraft Pneudraulics Repairer
- Inspector

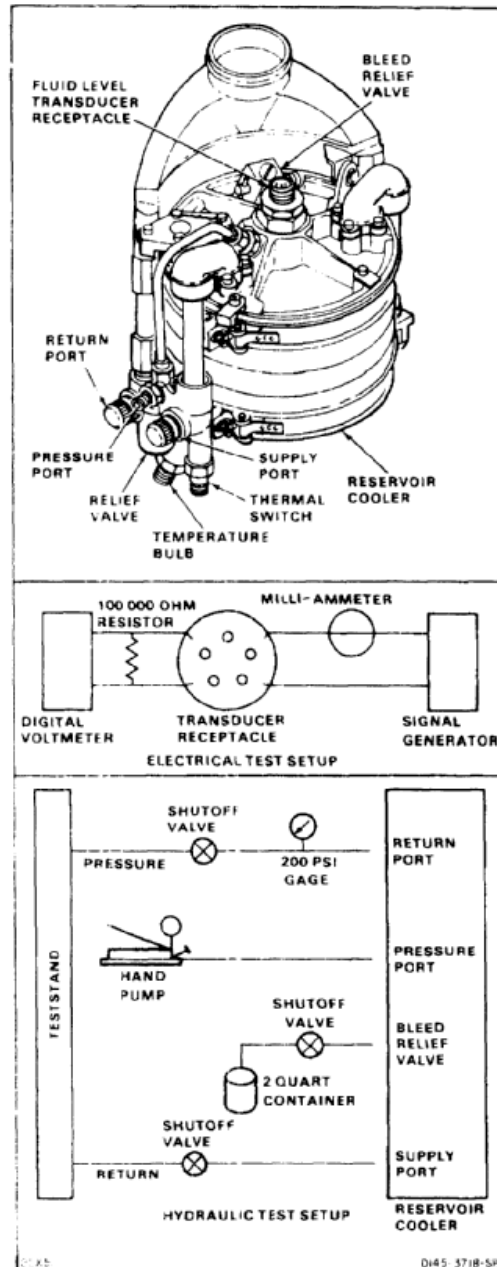

Equipment Condition:

- Off Helicopter Task
- Hydraulic Test Setup
- Electrical Test Setup
- Reservoir/Cooler Installed In Crast Proof Box
- Bleed Relief Valve, Relief Valve, Temperature Bulb And Temperature Switch Installed in Reservoir/Cooler

General Safety Instructions:

WARNING

Reservoir/cooler must be installed in crash proof box before performing test. Otherwise, injury to personnel can occur.

WARNING

Hydraulic fluid (E199) is toxic. It can irritate skin and cause burns. Avoid inhaling. Use only with adequate ventilation. Avoid contact with skin, eyes, or clothing. In case of contact, immediately flush skin or eyes with water for at least **15 minutes**. Get medical attention for eyes.

WARNING

Hydraulic fluid ejected under pressure can cause injury to personnel. Hydraulic fluid sprayed into the air is a fire hazard.

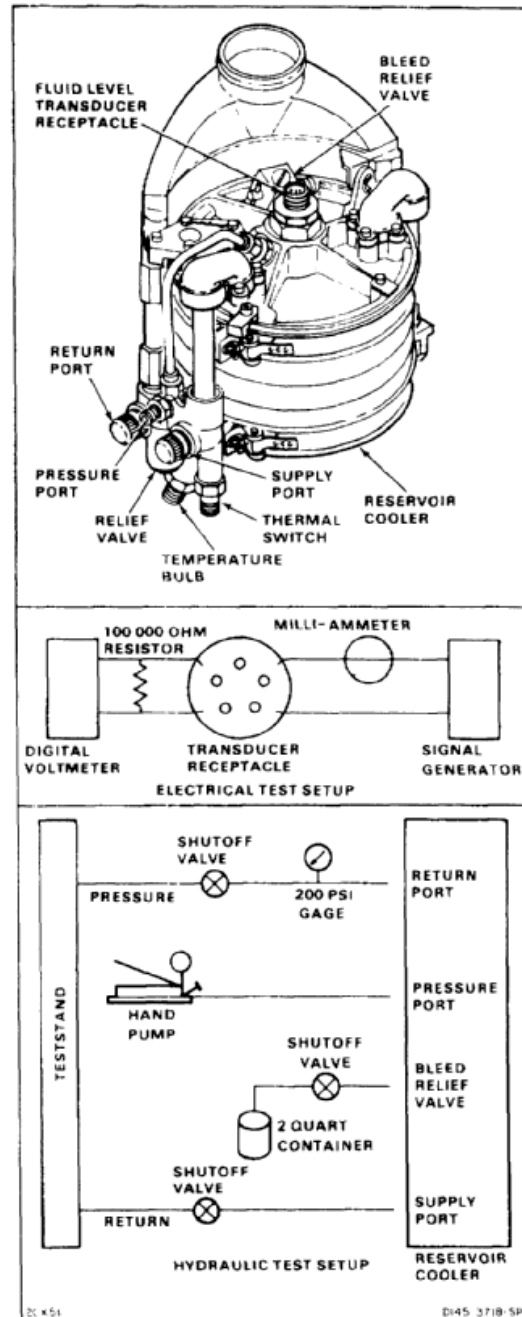

INTEGRITY PRESSURE TEST LOW-PRESSURE SIDE

1. Connect test setup pressure hose (1) to reservoir return port (2).
2. Connect hand pump pressure hose (3) to reservoir pressure port (4).
3. Connect test setup return hose (5) to reservoir supply port (6).
4. Connect drain hose (7) to reservoir bleed relief valve (8).
5. Close shutoff valve (9).
6. Close shutoff valve (10).

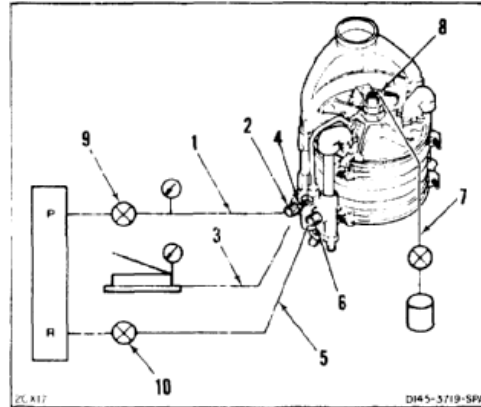

7. Open valve (9) and apply **5 to 20 psi** to return port (2) to fill reservoir (11). Open shutoff valve (12) and hold bleed valve (13) open until reservoir is free of air. Use cloths (E120) for spilled fluid. Use gloves (E186).
8. Close shutoff valve (12).
9. Open valve (9) and apply **20 psi** to return port (2). Maintain pressure for **2 minutes**.
10. Check reservoir (11) for leaks. There shall be no external leaks.

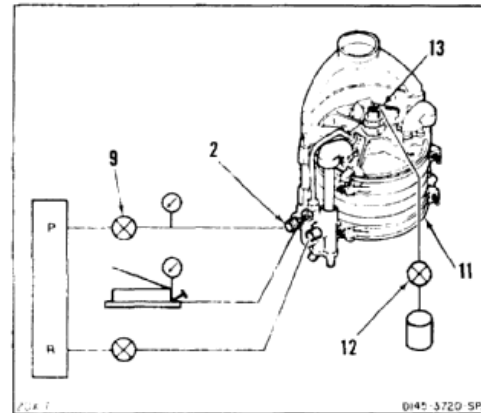

11. Make sure valve (14) is closed and apply **2000 psi** to pressure port (4).
12. Close and open valve (9) to lower and raise pressure at return port (2) from **120 to 0 psi** twice.
13. Check reservoir (11) for leaks and smooth operation of cylinder (15). There shall be no leaks, erratic movement or sticking of cylinder.
14. Repeat steps 12 and 13 twice, then go to step 15.
15. Open valve (10) to reduce pressure at return port (2) to **0 psi**.
16. Open valve (14) to reduce pressure at pressure port (4) to **0 psi**.

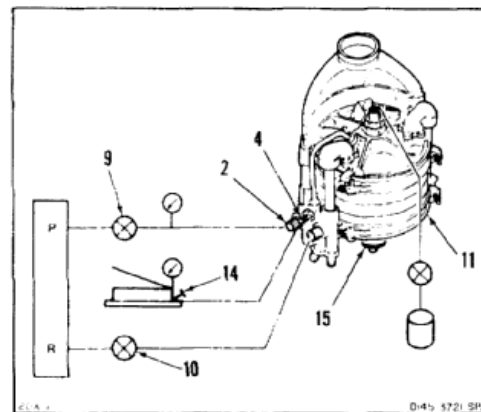

FLUID LEVEL TRANSDUCER ADJUSTMENT

26. Close valve (14).
27. Apply pressure to pressure port (4) until cylinder (15) bottoms in reservoir (11).
28. Mark line on cylinder (15) where cylinder enters housing (16). Use marking pencil (E271).
29. Open valve (14).
30. Close valve (10).
31. Open valve (9) and fill reservoir (11) until line on cylinder (15) is **1 inch** from empty position. Close valve.
32. Connect signal generator (17) to transducer receptacle (18). Pin numbers 1 and 2.
33. Connect voltmeter (19) to transducer receptacle (18). Pin numbers 3 and 4.
34. Apply **5 volts at 450 Hz** to transducer receptacle (18). Then adjust the milliammeter reads **10 ma**.

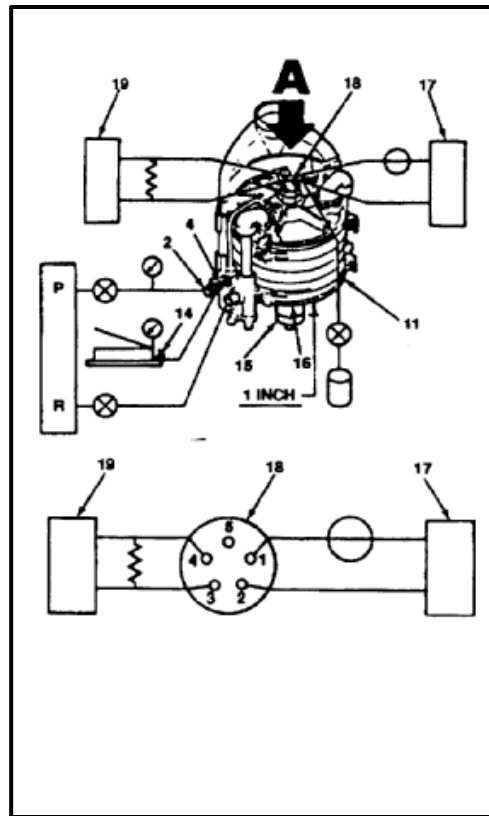

35. Open valve (9) and apply **60 psi** pressure to return port (2) until line on cylinder (15) is **4 inches** from housing (16).
36. Close valve (9).
37. Check reservoir (11) fluid level. Fluid level shall not change.
38. Remove two screws (20) from cylinder (15).
39. Turn square end of LVDT core (21) until voltmeter (19) reads **1.473 volts** rms.

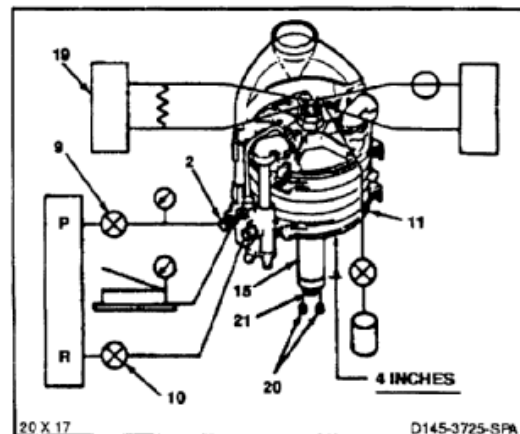

- 40. Install two screws (20) in cylinder (15). Torque screws to **20 inch-pounds**.
- 41. Lockwire screws (20) Use lockwire (E231).

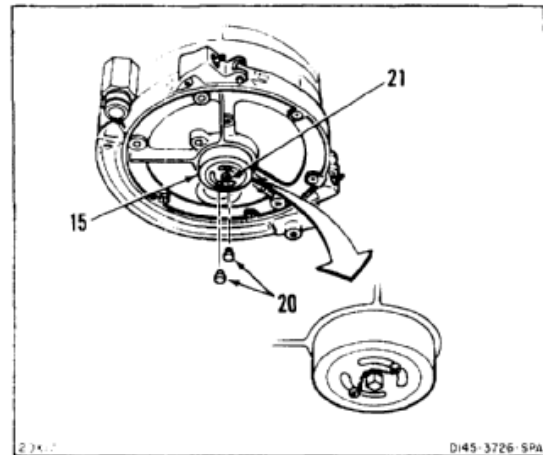

- 42. Open shutoff valve (10).
- 43. Close valve (14).
- 44. Apply pressure to port (4) until line on cylinder (15) aligns with housing (16).
- 45. Check voltmeter (19) readings. Voltmeter shall read **0 to 0.10 volt** rms.
- 46. Close valve (10).
- 47. Open valve (14).

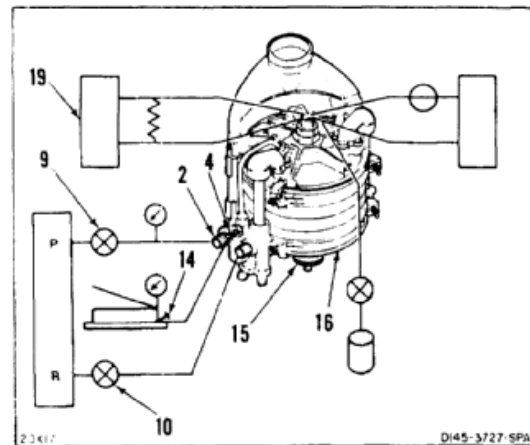

- 48. Open valve (9) and apply pressure to return port (2) until line on cylinder (15) is **5 inches** from housing (16).
- 49. Close shutoff valve (9).
- 50. Check that reservoir (11) fluid level does not change.
- 51. Check reading on voltmeter (19). Voltmeter shall read **1.801 to 1.881 volts** rms.
- 52. Open valve (10) to reduce pressure at return port (2) to **0 psi**.
- 53. Disconnect voltmeter (19) and signal generator (17) from transducer receptacle (18).

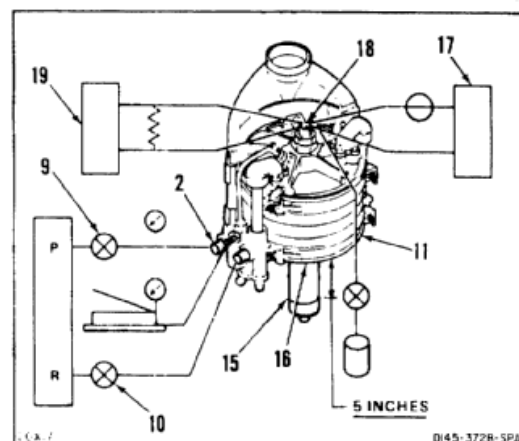

INTERNAL LEAKAGE TEST

54. Close shutoff valve (10).
55. Open shutoff valve (9) and apply **5 to 20 psi** to fill reservoir (11). Hold bleed relief valve (8) open until reservoir is free of air.
56. Close shutoff valves (9 and 12).
57. Close valve (14).
58. Check pressure gage (20) while applying **3000 psi** pressure to pressure port (4). Maintain pressure for **3 minutes**. There shall be no pressure increase during **3 minutes**.
59. Open shutoff valve (10) to reduce pressure at return port (2) to **0 psi**.
60. Open valve (14) to reduce pressure at pressure port (4) to **0 psi**.
61. Disconnect hose (1) from return port (2).
62. Disconnect hose (3) from pressure port (4).
63. Disconnect hose (5) from supply port (6).
64. Disconnect hose (7) from bleed relief value (8).
65. Use cloths (E120) for any spilled fluid.
66. Remove bleed relief valve (8) relief valve (21), thermal switch (22), and temperature bulb (23) from reservoir (11).

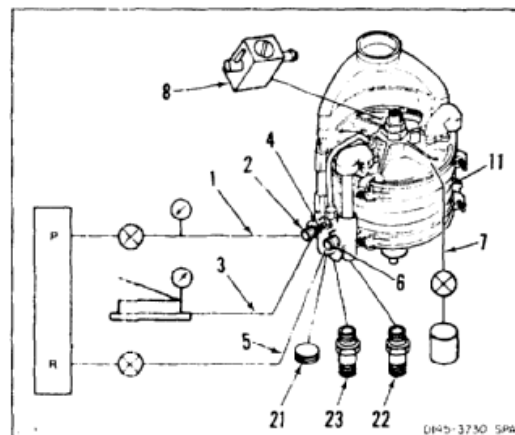
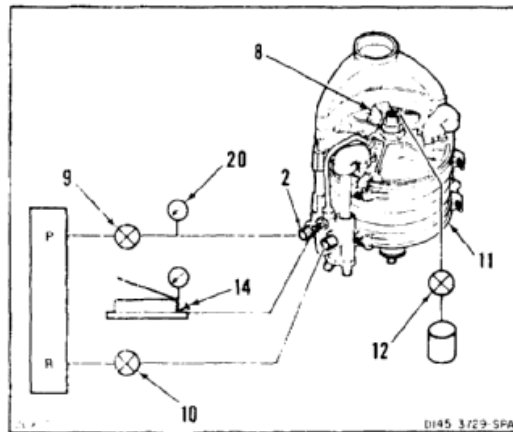
**INSPECT****FOLLOW-ON MAINTENANCE:**

None

END OF TASK

7-826

INITIAL SETUP

Applicable Configurations:

All

Tools:

Aircraft Mechanic's Tool Kit, NSN 51 80-00-323-4692
 Open-End Wrench, 1-1/4 Inch
 Open-End Wrench, 1/2 Inch

Materials:

Lockwire (E231)

Parts:

Preformed Packings
 Retainers

Personnel Required:

Medium Helicopter Repairer
 Inspector

References:

TM 55-1520-240-23

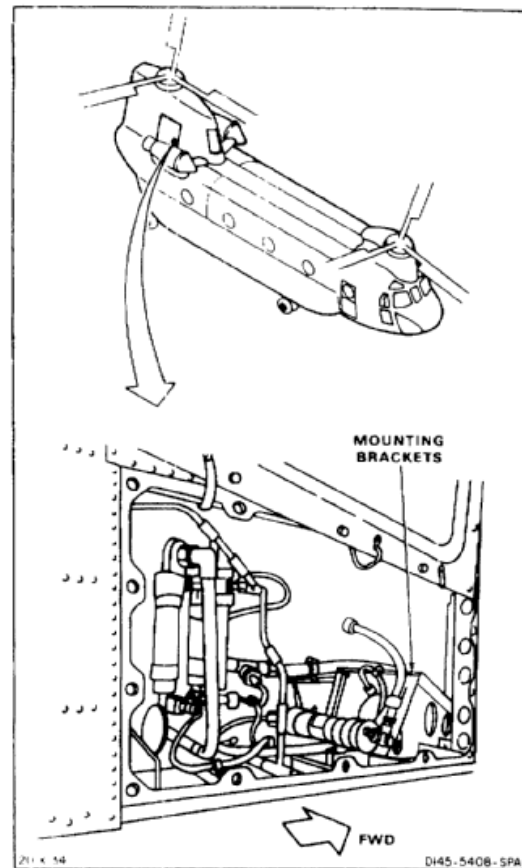

1. If reservoir/cooler (1) is a replacement, do the following:
 - a. Install bulb (2) and packing (3) in port (4).
 - b. Install switch (5) and packing (6) in port (7).
 - c. Install valve (8), retainer (9), packing (10), retainer (11), and packing (12) in port (13).
 - d. Lockwire bulb (2), switch (5), and valve (8). Use lockwire (E231).

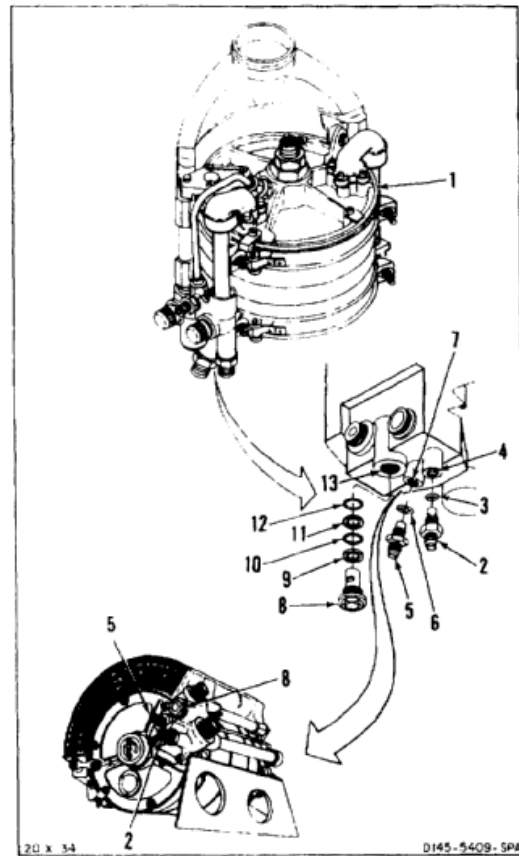

7-218 INSTALL UTILITY RESERVOIR/COOLER (Continued)**7-218**

- e. Install valve (14) and packing (15) in port (16).
- f. Install two screws (17) in valve (14).
- g. Lockwire screws (17). Use lockwire (E231).

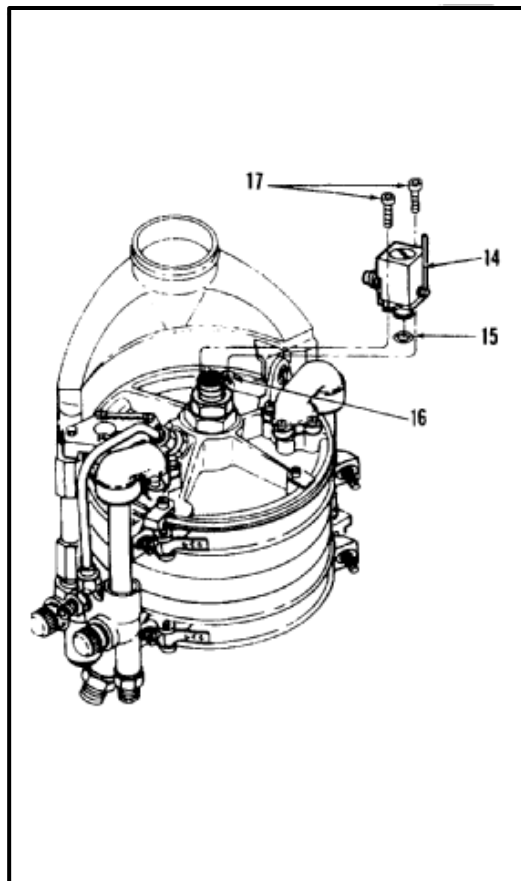
INSPECT

2. Position reservoir/cooler (1) on brackets (18). Install four nuts (19) and washers (20).
3. Connect tube (21) to RTN port (22). Remove tag.
4. Connect tube (23) to SPLY port (24). Remove tag.
5. Connect tube (25) to port (26). Remove tag.
6. Connect cable plug (27) to bulb (2). Remove tag.
7. Connect cable plug (28) to switch (4). Remove tag.
8. Connect cable plug (29) to receptacle (30). Remove tag.
9. Connect hose (31) to valve (13). Tighten clamp (32). Remove tag.
10. Position duct (33) to reservoir/cooler (17). Tighten clamp (34).
11. Lockwire clamp (34). Use lockwire (E231).

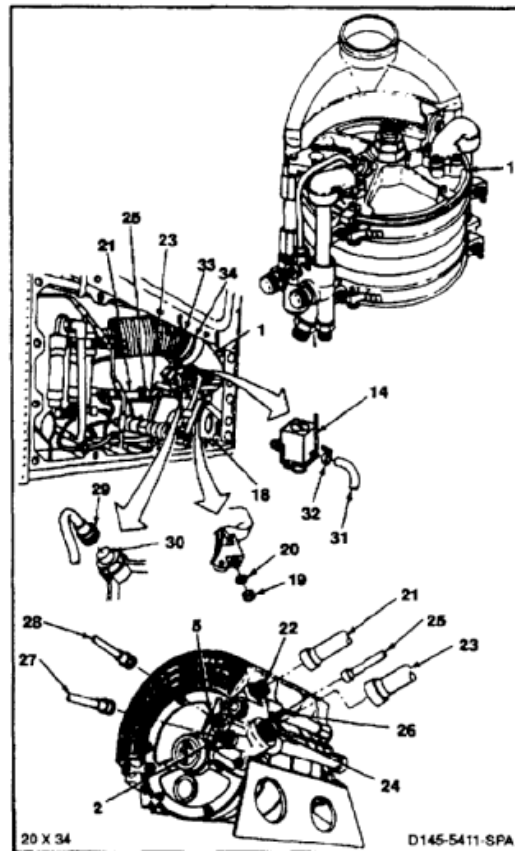
INSPECT**FOLLOW-ON MAINTENANCE:**

- Service reservoir (Task 1-60 or 1-63).
- Bleed utility hydraulic system (Task 7-336).
- Perform operational check (TM 55-1520-240-T).
- Close right aft pylon access doors (Task 2-2).

END OF TASK

7-830

7-218.1 REMOVE UTILITY HYDRAULIC SYSTEM ACCUMULATOR

7-218.1

INITIAL SETUP**Applicable Configurations:**

All

Tools:

Aircraft Mechanic's Tool Kit, NSN 5180-00-323-4692
Soft Jawed Vise

Materials:

Cloths (E135)

Personnel Required:

Medium Helicopter Repairer

References:

TM 1-1520-253-23

Equipment Condition:

Battery Disconnected (Task 1-39)
Electrical Power Off
Hydraulic Power Off
Utility Hydraulic System and Accumulator
Depressurized (Task 7-135.1)
Pylon Right Access Door Open (Task 2-2.1)

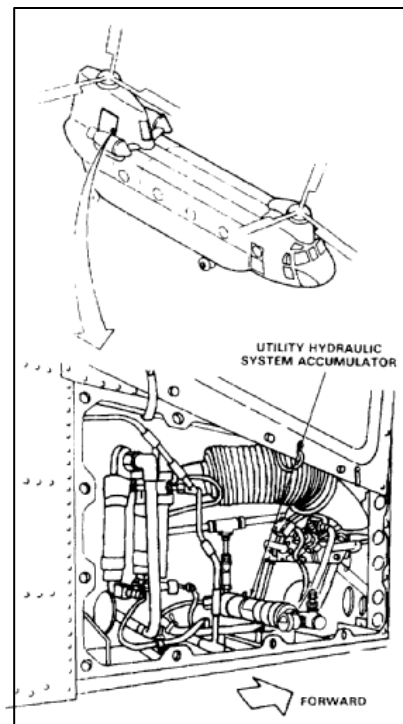
**NOTE**

If a crack in the accumulator is suspected during removal, refer to TM 1-1520-253-23.

1. Disconnect tube (1) from tee (2). Use cloths (E135) for spilled fluid.
2. Disconnect relief valve (3) from tee (2).
3. Remove lockwire from two clamps (4).
4. Remove two nuts (5) from clamps (4). Open clamps.
5. Remove accumulator (6).

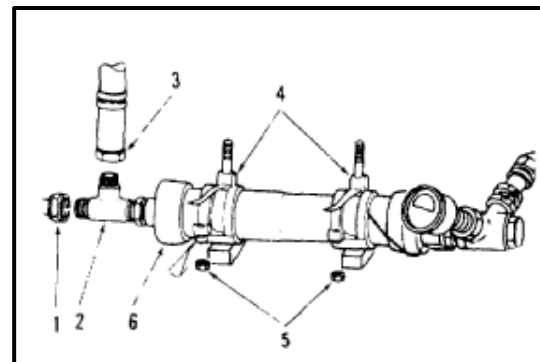

6. Clamp accumulator (6) in vise (7). Use soft jawed vise.
7. Loosen nut (8) of tee (2). Remove tee, washer (9), and packing (10) from accumulator (6).
8. Loosen nut (11) of fitting (12). Remove fitting, packing (13), and washer (14) from accumulator (6).
9. Remove accumulator (6) from vise (7).

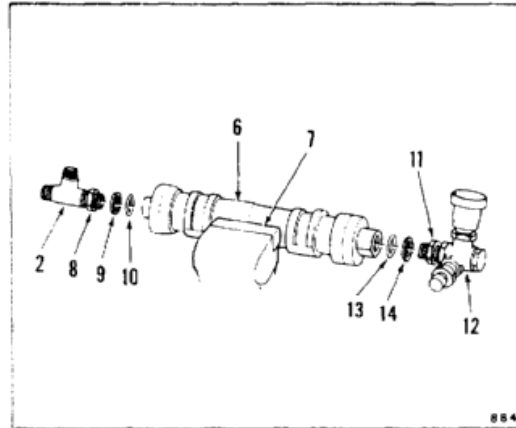
**FOLLOW-ON MAINTENANCE:**

None

END OF TASK

7-832

7-218.2 INSTALL UTILITY HYDRAULIC SYSTEM ACCUMULATOR

7-218.2

INITIAL SETUP**Applicable Configurations:**

All

Tools:

Aircraft Mechanic's Tool Kit, NSN 51 80-00-323-4692
Soft Jawed Vise

Materials:

Lockwire (E231)

Parts:

Preformed Packings
Washers

Personnel Required:

Medium Helicopter Repairer
Inspector

References:

TM 55-1520-240-T

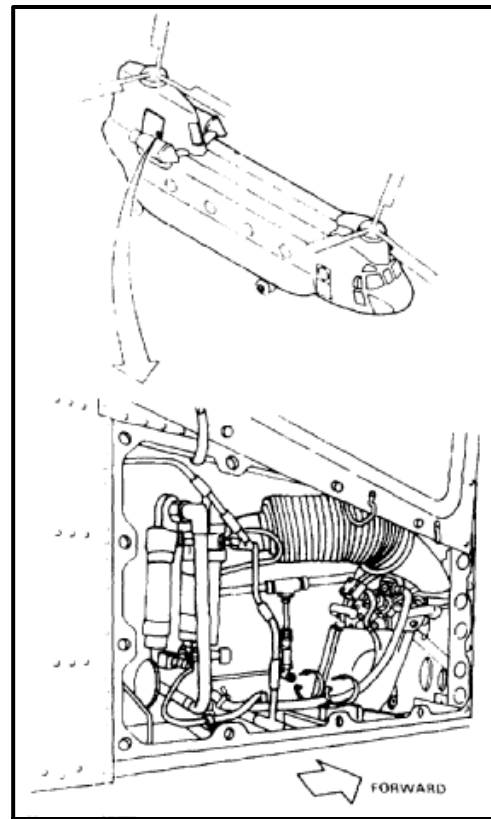

1. Clamp accumulator (1) in vise (2). Use soft jawed vise.
2. Install packing (3), washer (4), and fitting (5) in GAS port (6) of accumulator (1). Tighten nut (7).
3. Install packing (8), washer (9), and tee (10) in HYD port (11) of accumulator (1). Do not tighten nut (12) at this time.
4. Remove accumulator (1) from vise (2).

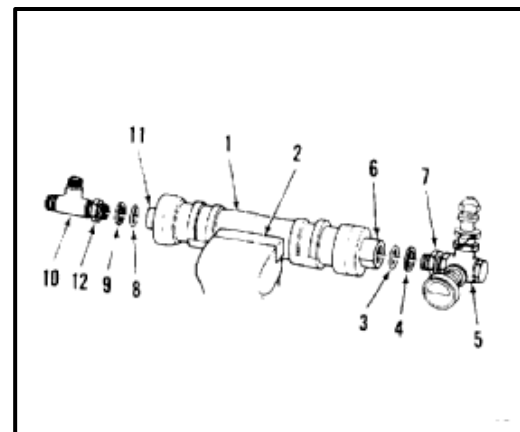

5. Working from pylon right access door, position accumulator (1) in two clamps (13), fitting (5) outboard, and valve (14) upright.
6. Close clamps (13) and install two nuts (15). Do not tighten nuts at this time.
7. Connect valve (16) to tee (10) of accumulator (1).
8. Connect tube (17) to tee (10).
9. Tighten nuts (15).
10. Tighten nut (12).
11. Lockwire clamps (13). Use lockwire (E231).
12. Lockwire nut (18) to accumulator (1). Use lockwire (E231).

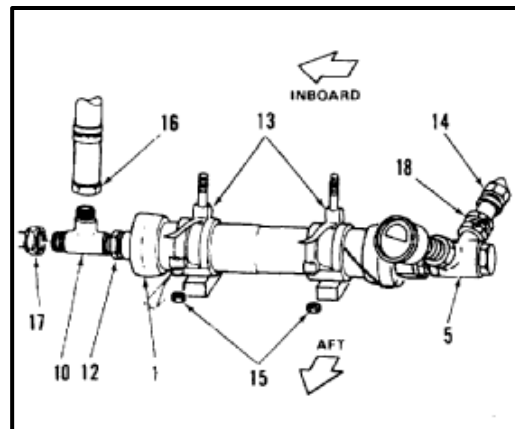
**INSPECT****FOLLOW-ON MAINTENANCE:**

- Service utility hydraulic system and accumulator (Task 1-59 and 1-68).
- Bleed hydraulic system (refer to Index).
- Perform operational check (TM 55-1520-240-T).
- Close pylon right access door (Task 2-2).

END OF TASK

7-218.3 REMOVE UTILITY SYSTEM ACCUMULATOR RELIEF VALVE

7-218.3

INITIAL SETUP**Applicable Configurations:**

All

Tools:

Aircraft Mechanic's Tool Kit, NSN 5180-00-323-4692

Materials:Cloths (E135)
Paper Tags (E264)**Personnel Required:**

Medium Helicopter Repairer

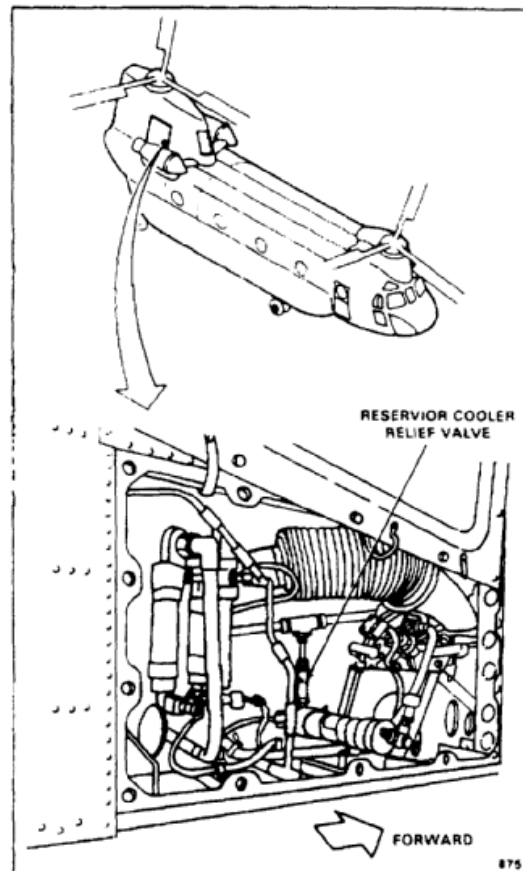
Equipment Condition:Battery Disconnected (Task 1-39)
Electrical Power Off
Hydraulic Power Off
Utility Hydraulic System Depressurized (Task 7-135.1)
Pylon Right Access Door Open (Task 2-2)

1. Tag and disconnect tube (1) from tee (2) and return port of relief valve (3). Use paper tags (E264). Remove tube. Use cloths (E135) for spilled fluid.
2. Disconnect pressure port of valve (3) from tee (4) on accumulator (5). Remove valve.

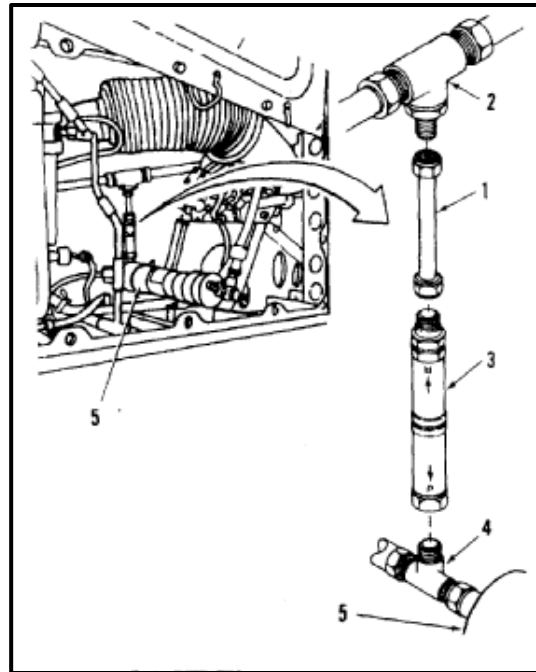

3. Remove nipple (5) and packing (6) from valve (3).

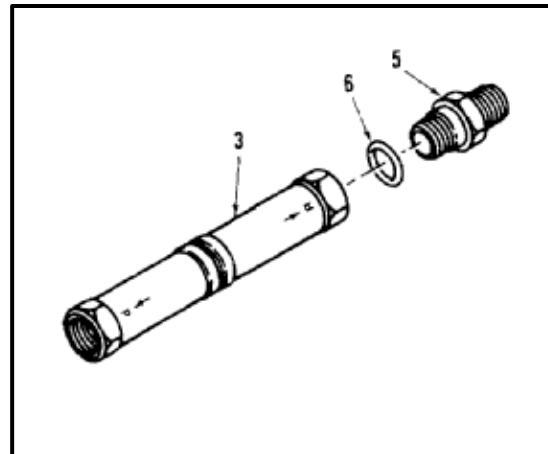
**FOLLOW-ON MAINTENANCE:**

None

END OF TASK

7-836

7-218.4 INSTALL UTILITY SYSTEM ACCUMULATOR RELIEF VALVE

7-218.4

INITIAL SETUP

Applicable Configurations:

All

Tools:

Aircraft Mechanic's Tool Kit, NSN 51 80-00-323-4692

Materials:

None

Parts:

Preformed Packings

Personnel Required:

Medium Helicopter Repairer
Inspector

References:

TM 55-1520-240-23P

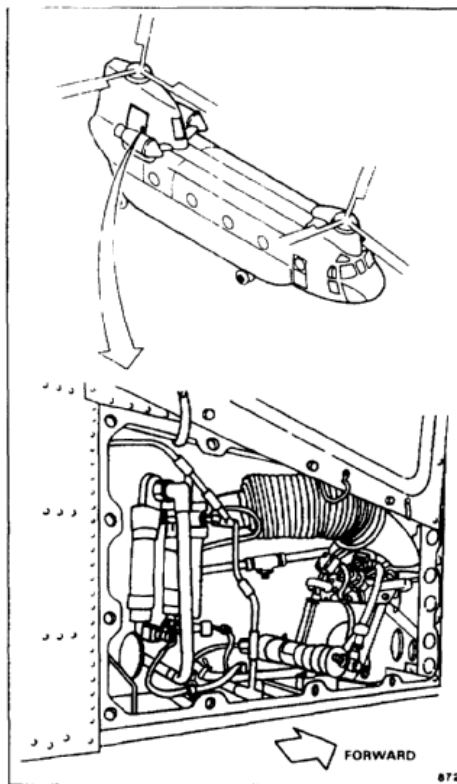

1. Install packing (1) and nipple (2) in relief valve (3).

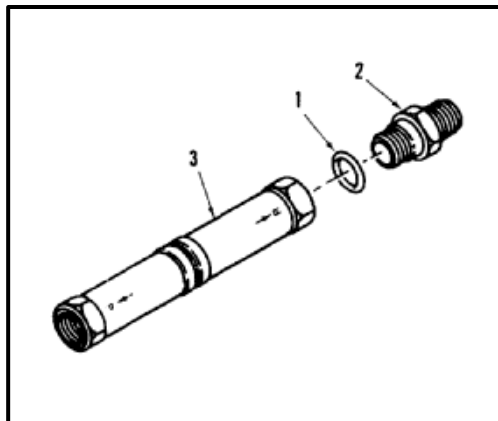

2. Connect pressure port of valve (3) to tee (4) on accumulator (5).
3. Connect tube (6) to return port of valve (3) and tee (7). Remove tag from tube (6).

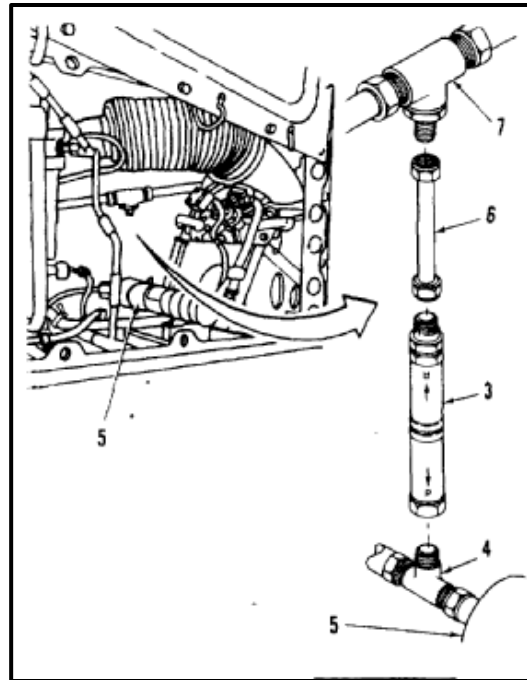
INSPECT***FOLLOW-ON MAINTENANCE:***

- Service utility hydraulic system (Task 1-62).
- Perform operational check (TM 55-1520-240-T).
- Close pylon right access door (Task 2-2).

END OF TASK

7-838

7-219 REMOVE UTILITY COOLING FAN

7-219

INITIAL SETUP**Applicable Configurations:**

All

Tools:

Aircraft Mechanic's Tool Kit, NSN 51 80-00-323-4692

Materials:

None

Personnel Required:

Medium Helicopter Repairer

Equipment Condition:

Battery Disconnected (Task 1-39)

Electrical Power Off

Right Pylon Access Panels Open (Task 2-2)

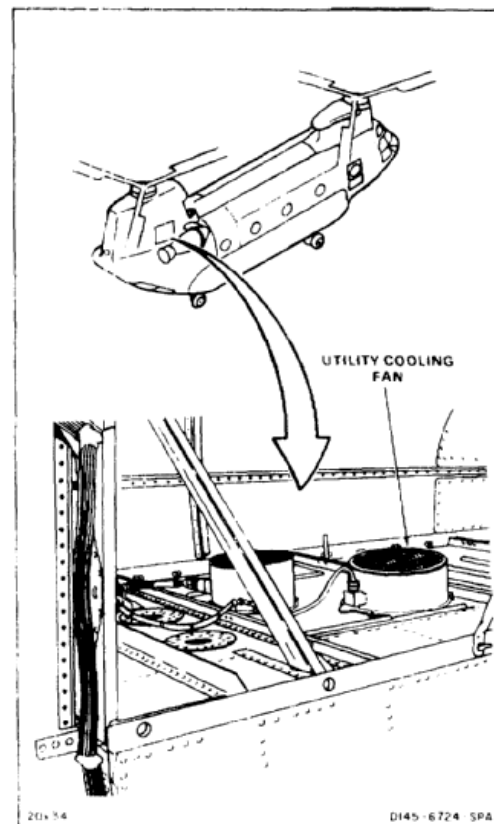

1. Loosen nut (1) on clamp (2). Slide clamp over duct (3).
2. Remove duct (3) from fan (4).

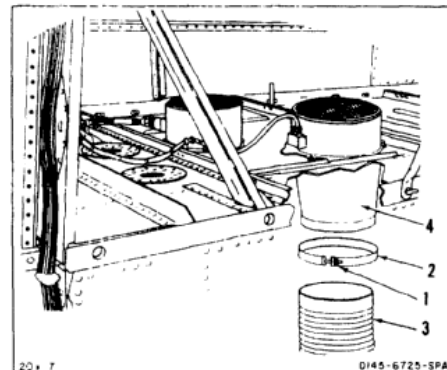

3. Disconnect electrical plug (5) from fan (4).
4. Remove four bolts (6) and washers (7).
5. Remove fan (4).

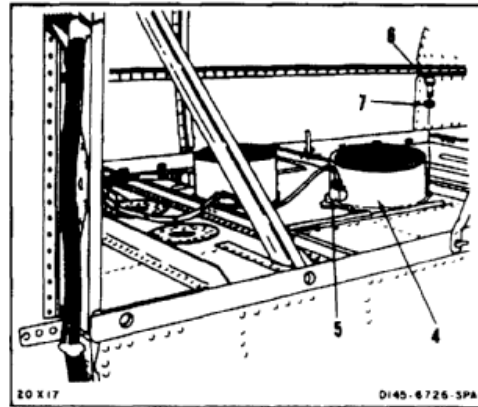

6. Remove four screws (8) and washers (9) from screen (10). Remove screen.

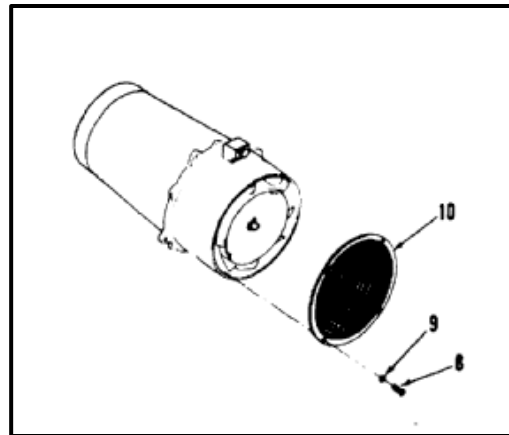
**FOLLOW-ON MAINTENANCE:**

None

Tasks 7-220 thru 7-222 have been deleted.

END OF TASK

7-840

INITIAL SETUP

Applicable Configurations:

All

Tools:

Aircraft Mechanic's Tool Kit, NSN 51 80-00-323-4692

Materials:

Lockwire (E231)

Personnel Required:

Medium Helicopter Repairer
Inspector

References:

TM 55-1520-240-23P

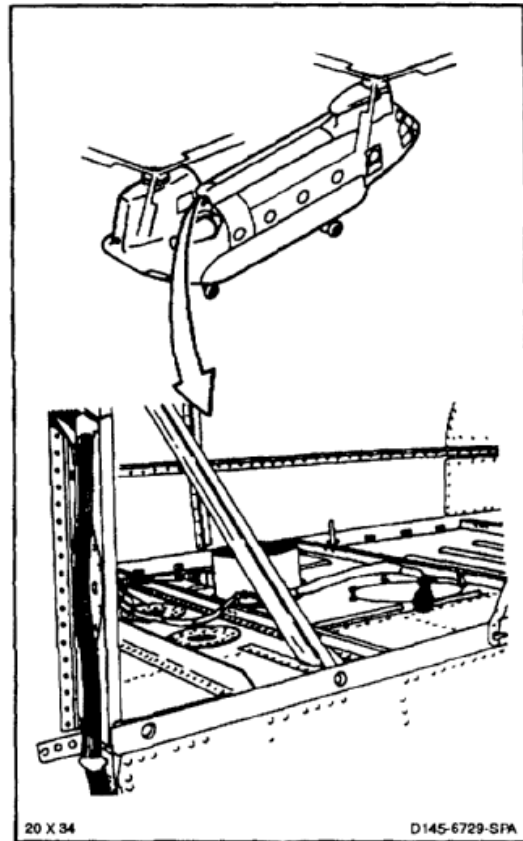

1. Position screen (1) on fan (2). Install four screws (3) and washers (4).

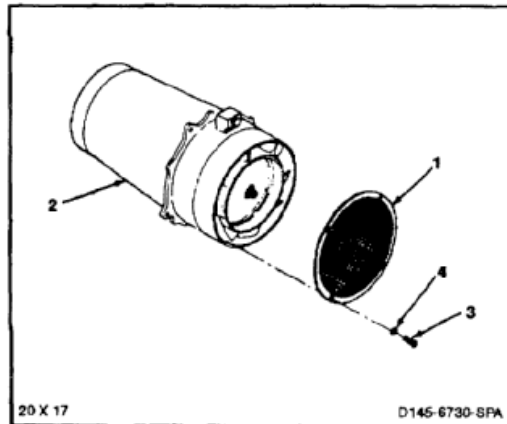

CAUTION

Damage to lugs may occur if lugs are not set flat against structure during tightening.

2. Position fan (2) on structure (5) with receptacle (6) facing outboard. Make sure lugs (4.1) are set flat against structure.
3. Install four bolts (7) and washers (8). Torque bolts to **70 inch-pounds**.
4. Connect electrical plug (9) to receptacle (6).
5. Install duct (10) and clamp (11) on fan (3). Tighten nut (12).
6. Lockwire clamp (11). Use lockwire (E231).

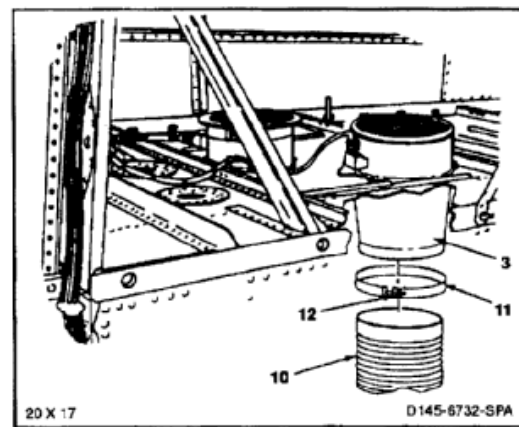
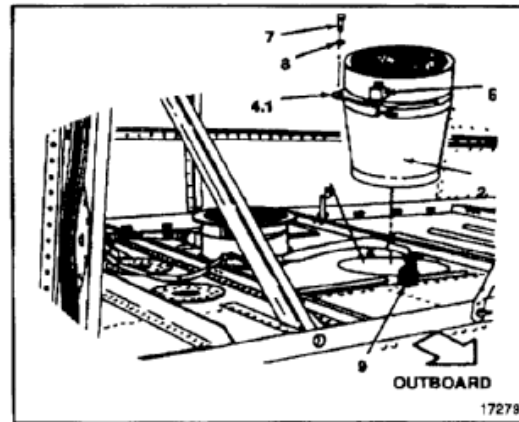
INSPECT**FOLLOW-ON MAINTENANCE:**

- Perform operational check of cooling fan (TM 55-1520-240-T).
- Close right pylon access panels (Task 2-2).

END OF TASK

7-842

INITIAL SETUP

Applicable Configurations:

All

Tools:

Aircraft Mechanic's Tool Kit, NSN 5180-00-323-4692

Materials:

Cloths (E120)
 Paper Tags (E264)
 Gloves (E186)

Personnel Required:

Medium Helicopter Repairer

Equipment Condition:

Battery Disconnected (Task 1-39)
 Electrical Power Off
 Hydraulic Power Off
 Utility Hydraulic System Depressurized (Task 7-135.1)
 Pilot's or Copilot's Seat Fully Aft

General Safety Instructions:**WARNING**

Hydraulic fluid (E199) is toxic. It can irritate skin and cause burns. Avoid inhaling. Use only with adequate ventilation. Avoid contact with skin, eyes, or clothing. In case of contact, immediately flush skin or eyes with water for at least **15 minutes**. Get medical attention for eyes.

WARNING

Hydraulic fluid ejected under pressure can cause injury to personnel. Hydraulic fluid sprayed into the air is a fire hazard.

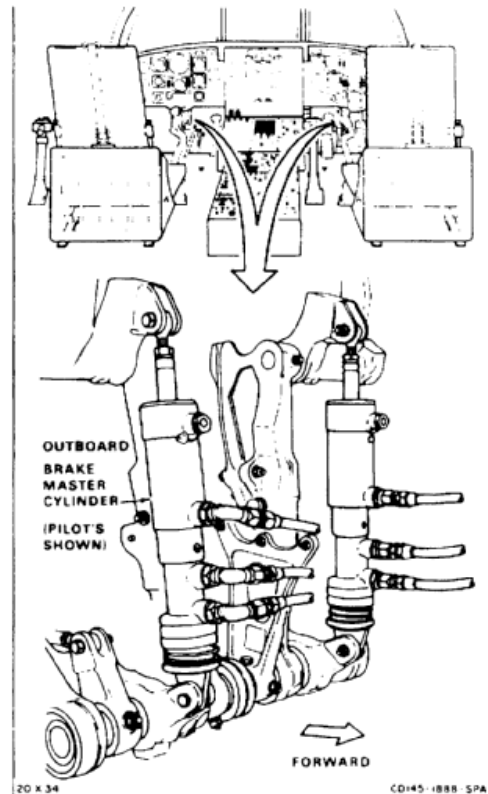

NOTE

Procedure is same to remove pilot's or copilot's outboard cylinder. Pilot's cylinder is shown here.

1. Operate cockpit foot brake pedals ten times to relieve system pressure.
 - 1.1. Tag and disconnect three hydraulic hoses (1) from cylinder (2). Use cloths (E120) for spilled fluid. Use gloves (E186).
2. Remove cotter pin (3), nut (4), two washers (5), and bolt (6).
3. Hold cylinder (2). Remove cotter pin (7), nut (8), two washers (9), and bolt (10). Remove cylinder.
 4. Loosen three nuts (11). Remove three elbows (12), washers (13), and packings (14) from cylinder (2).
 5. Remove scupper (15) from shaft.

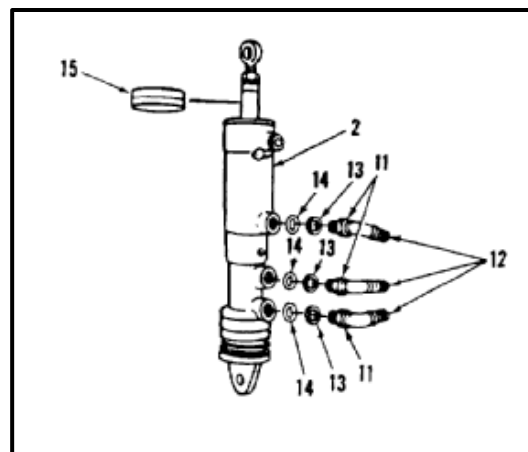
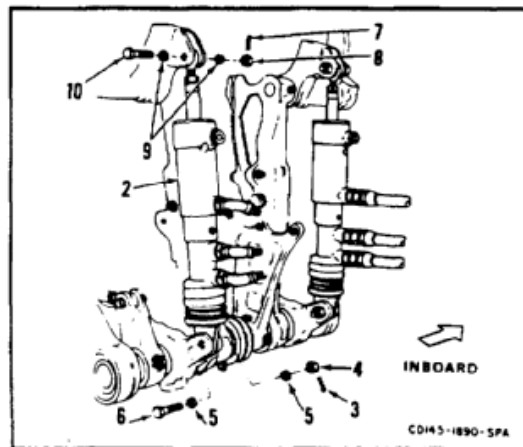
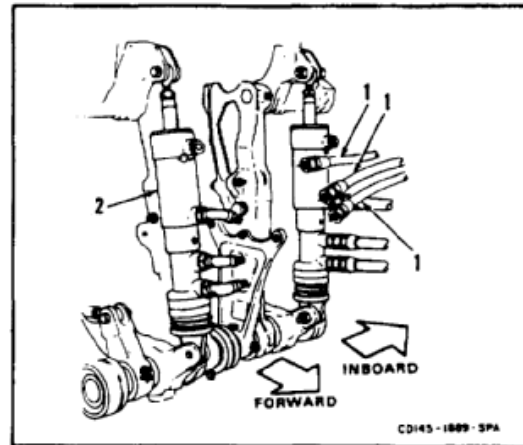
**FOLLOW-ON MAINTENANCE:**

None

END OF TASK

7-844

7-225 REMOVE INBOARD BRAKE MASTER CYLINDER

7-225

INITIAL SETUP**Applicable Configurations:**

All

Tools:

Aircraft Mechanic's Tool Kit, NSN 51 80-00-323-4692
Container, 2 Quart

Materials:

Cloths (E120)
Paper Tags (E264)
Gloves (E186)

Personnel Required:

Medium Helicopter Repairer

Equipment Condition:

Battery Disconnected (Task 1-39)
Electrical Power Off
Hydraulic Power Off
Utility Hydraulic System Depressurized (Task 7-135.1)
Pilot's or Copilot's Seat Fully Aft

General Safety Instructions:**WARNING**

Hydraulic fluid (E199) is toxic. It can irritate skin and cause burns. Avoid inhaling. Use only with adequate ventilation. Avoid contact with skin, eyes, or clothing. In case of contact, immediately flush skin or eyes with water for at least **15 minutes**. Get medical attention for eyes.

WARNING

Hydraulic fluid ejected under pressure can cause injury to personnel. Hydraulic fluid sprayed into the air is a fire hazard.

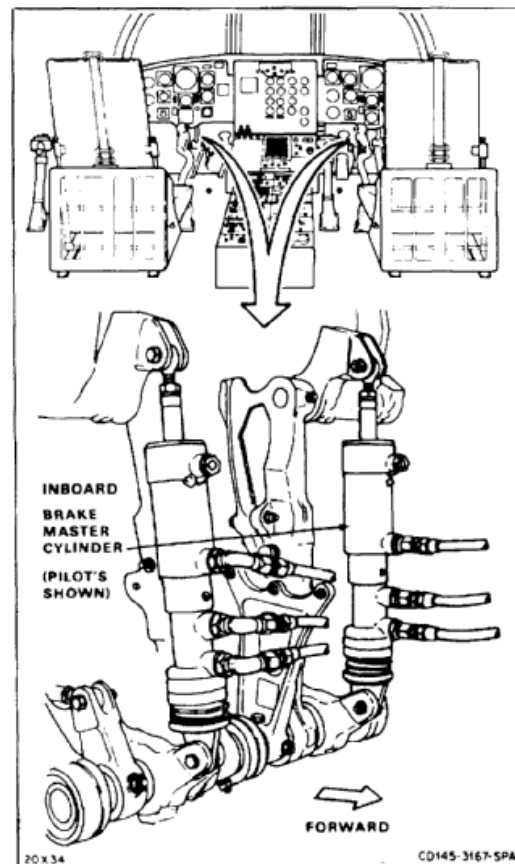

NOTE

Procedure is same to remove pilot's or copilot's inboard cylinder. Pilot's inboard cylinder is shown here.

1. Operate cockpit foot brake pedals ten times to relieve system pressure.
- 1.1. Tag and disconnect three hydraulic hoses (1) from cylinder (2). Use container and cloths (E120) for spilled fluid. Use gloves (E186).
2. Remove cotter pin (3), nut (4), two washers (5), and bolt (6).
3. Hold cylinder (2). Remove cotter pin (7), nut (8), two washers (9), and bolt (10). Remove cylinder.

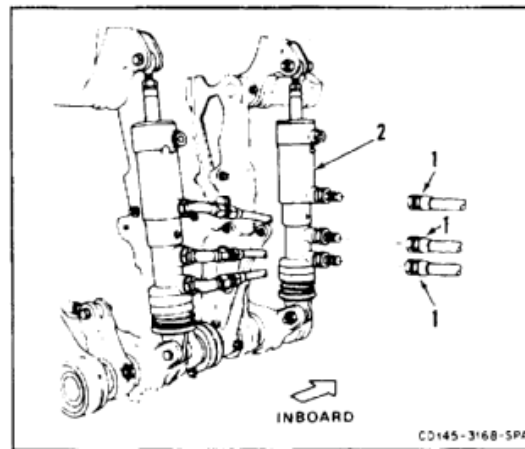
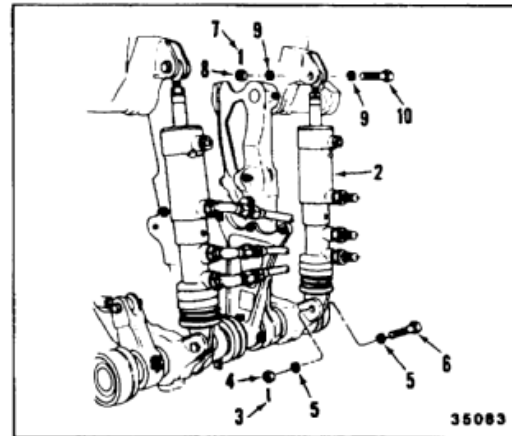

4. Remove three nipples (11) and packings (12) from cylinder (2).
5. Remove scupper (13) from shaft.

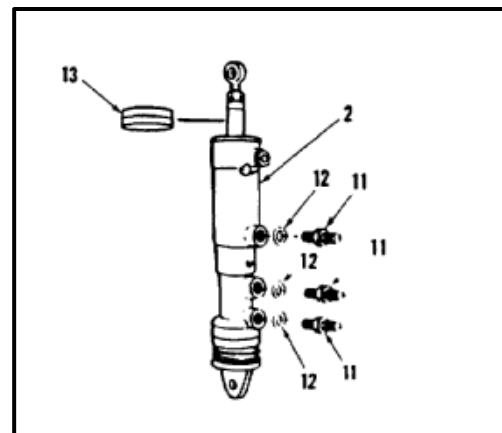

FOLLOW-ON MAINTENANCE:

None

END OF TASK

INITIAL SETUP

Applicable Configurations:

All

Tools:

Hydraulic Repairer's Tool Kit, NSN 5180-00-323-4891
Open End Wrench, 1-3/4 Inch
Blind Hole Puller Set, NSN 5180-01-008-7974
Strap Wrench
Technical Inspection Tool Kit, NSN 5180-00-323-5114
Outside Micrometer Caliper Set
Telescoping Gage Set

Materials:

Dry Cleaning Solvent (E162)
Gloves (E184.1)
Cloths (E120)
Barrier Material (E80)

Personnel Required:

Aircraft Pseudraulics Repairer (2)
Inspector

References:

TM 55-1500-322-24

Equipment Condition:

Off Helicopter Task

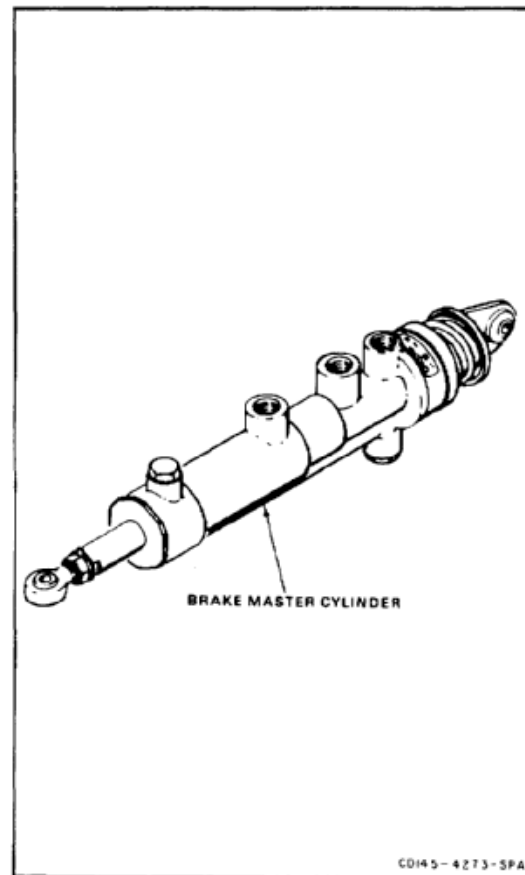

NOTE

Inspection steps in this task cover only those parts of the brake master cylinder that are most subject to wear. All parts shall also be inspected for obvious damage such as cracks, corrosion, and damaged threads.

1. Remove lockwire and loosen nut (1).

WARNING

Rod end bearing is spring-loaded. Remove rod end bearing carefully to prevent injury to personnel.

2. Turn rod end bearing (2) counterclockwise and remove it from rod (3).
3. Remove washer (4) and nut (1) from rod end bearing (2).
- 3.1. Inspect rod end bearing (2) (TM 55-1500-322-24).
4. Turn cylinder upside down and remove spring (5) and pin (6).

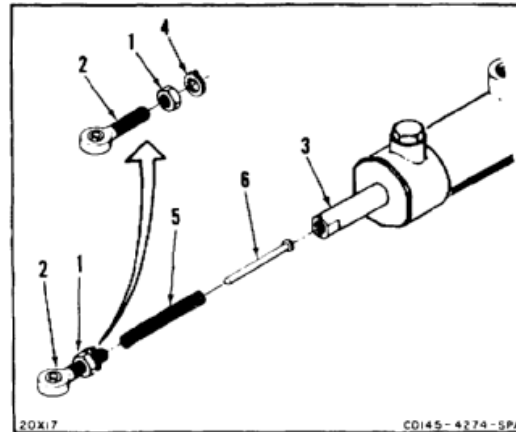
**WARNING**

End cap is spring-loaded. Remove end cap carefully to prevent injury to personnel.

5. Remove lockwire and end cap (7) from housing (8).
6. Remove packings (9, 10 and 11) from end cap (7).
- 6.1. Measure diameter of bore (11.1) in end cap (7). Diameter shall not be more than **0.627 inch**.

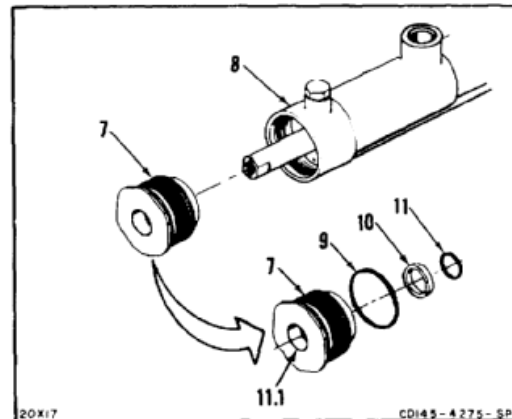

7. Remove rod (3) and spring (12) from housing (8).
8. Remove guide (13) from housing (8). Use blind hole puller. If blind hole puller is not available, remove guide from housing as follows:

WARNING

Dry cleaning solvent (E162) is flammable and toxic. It can irritate skin and cause burns. Use only in well-ventilated area, away from heat and open flame. In case of contact, immediately flush skin or eyes with water for at least **15 minutes**. Get medical attention for eyes.

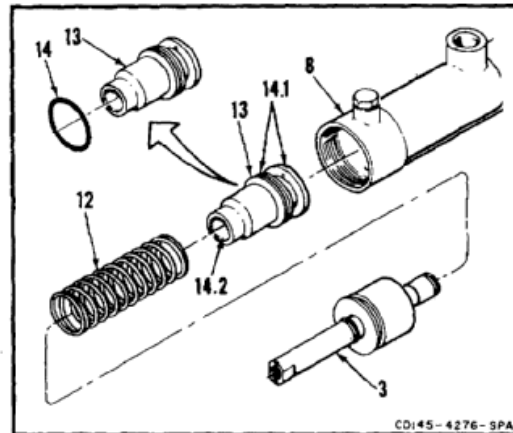

- a. Flush housing (8) with dry cleaning solvent (E162). Wear goggles and gloves (E184.1).
 - b. Spread barrier material (E80) on workbench.
 - c. Tap housing (8) on workbench to remove guide (13).
9. Remove packing (14) from guide (13).
 - 9.1. Measure diameter of lands (14.1) and bore (14.2) of guide (13). Lands shall not be less than **1.185 inches**. Bore shall not be more than **0.626 inch**.
 10. Remove packing (15), seat (16), retaining ring (17), and piston (18) from rod (3).
 11. Remove packing (19) from piston (18).
 - 11.1. Measure outside diameter of rod (3) at two places (19.1). Diameter shall not be less than **0.623 inch**.
 - 11.2. Measure outside diameter of piston (18). Diameter shall not be less than **1.516 inches**.

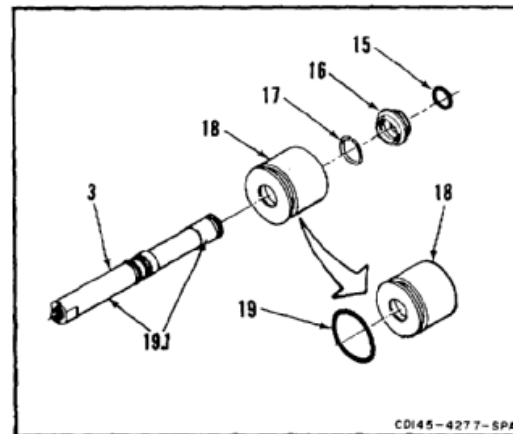

12. Have helper depress guide (20) against spring (21) and remove retaining ring (22).
13. Remove guide (20), spring (21), and spacer (23) from rod end connector (24).
14. If data plate (25) is damaged, remove it from cap (26).

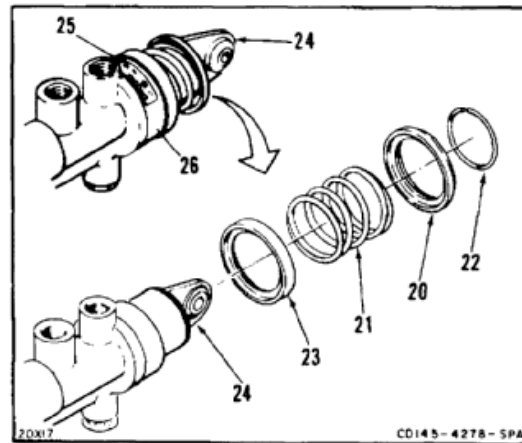

15. Remove cap (26). Use strap wrench. Remove rod end connector (24) and pin (27) from housing (8).
16. If bearing (28) is damaged, remove it from connector (24) (TM 55-1520-322-24).
- 16.1. Measure inside diameter of connector (24). Diameter shall not be more than **1.377 inches**.
17. Turn sleeve (29) counterclockwise and remove it from housing (8).
18. Remove sleeve (29), piston (30), shim (31), spring (32), and guide (33) from housing (8).
- 18.1. Measure outside diameter of piston (30). Diameter shall not be less than **0.872 inch**.
19. Remove packing (34) from sleeve (29).
- 19.1. Measure inside diameter of sleeve (29). Diameter shall not be more than **0.876 inch**.

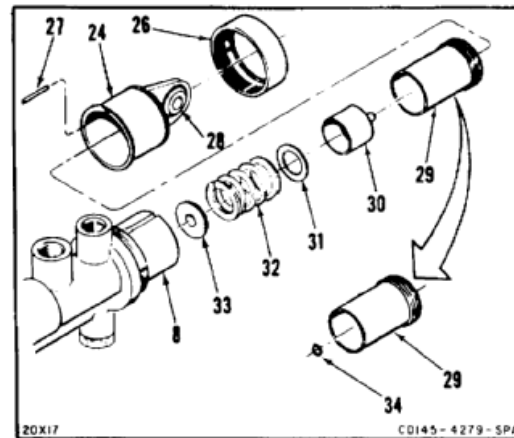

CAUTION

Handle selector set with care to prevent damage to mating surfaces.

20. Tap housing (8) on workbench to remove selector set (35).
21. Remove three packings (36) and two retainers (37) from selector set (35).

NOTE

Piston and sleeve are a matched set. If one is damaged, both must be replaced.

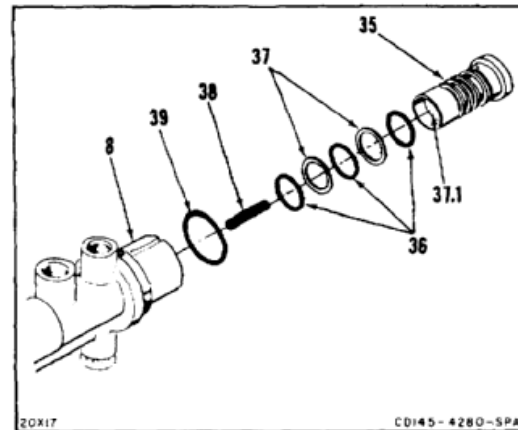

22. Check that piston (37.1) slides easily in bore of selector set (35). Do not remove piston.
23. Remove spring (38) and packing (39) from housing (8).
24. Remove lockwire from plug (40). Remove plug, spring (41), and poppet (42) from housing (8).
25. Check poppet (42) and mating seat in housing (8). There shall be no nicks or scratches.
26. Remove packing (43) from plug (40).
27. Remove lockwire and plug (44) from housing (8).
28. Remove packing (45) and plug (44).
29. Measure inside diameter of housing (8) at two places (46 and 47). Large diameter (46) shall not be more than **1.521 inches**. Small diameter (47) shall not be more than **1.191 inches**.
30. Measure outside diameter of housing (8) at end (48). Diameter shall not be less than **1.372 inches**.

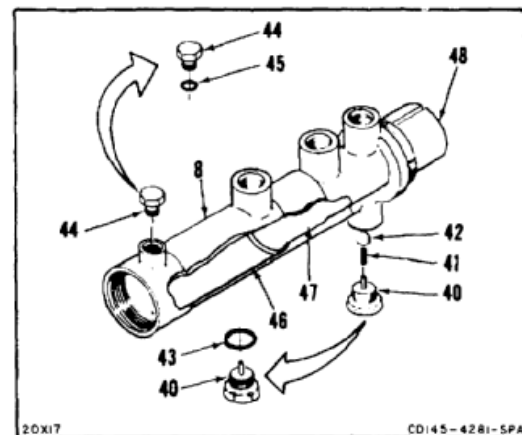

FOLLOW-ON MAINTENANCE:

None

END OF TASK

INITIAL SETUP

Applicable Configurations:

All

Tools:

Hydraulic Repairer's Tool Kit, NSN 5180-00-323-4891
 Open End Wrench, 1-3/4 Inch
 Strap Wrench

Materials:

Lockwire (E231)

Parts:

Preformed Packings
 Retainers

Personnel Required:

Aircraft Pneudraulics Repairer (2)
 Inspector

References:

TM 55-1520-240-23P
 TM 55-1500-322-24

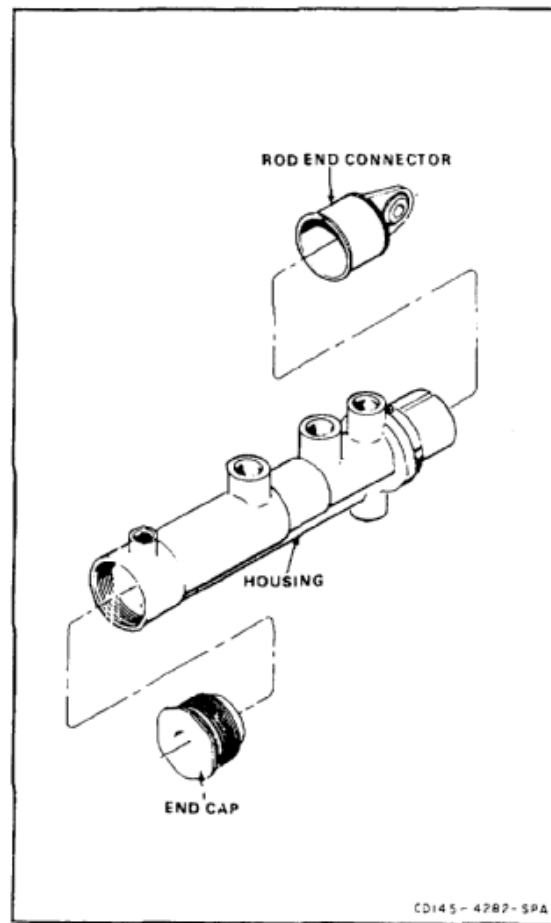

1. Install packing (1) on plug (2).
2. Install plug (2) in housing (3).
3. Lockwire plug (2). Use lockwire (E231).
4. Install packing (4), spring (5), and poppet (6) on plug (7).
5. Install plug (7) in housing (3).
6. Lockwire plug (7) to housing (3). Use lockwire (E231).

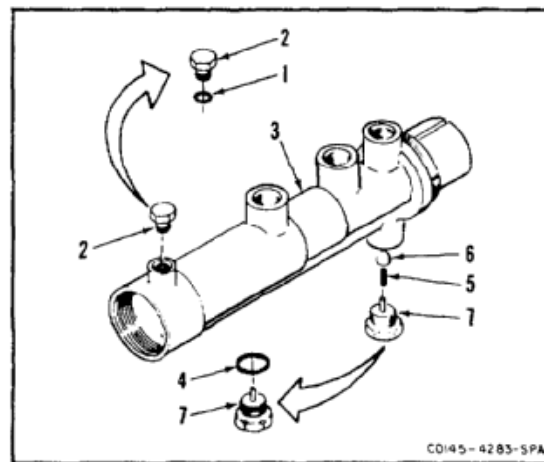

7. Install three packings (8) and two retainers (9) on selector set (10).
8. Install packing (11) and spring (12) in housing (3).
9. Install selector set (12) in housing (3).

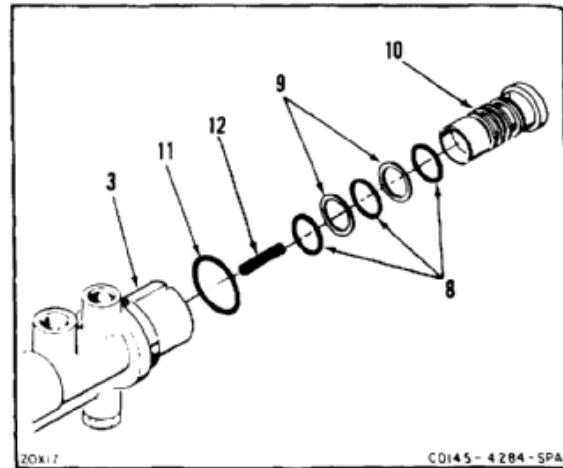

10. Install packing (13) in sleeve (14).
11. Install guide (15), spring (16), shim (17), piston (18), and sleeve (14) in housing (3).

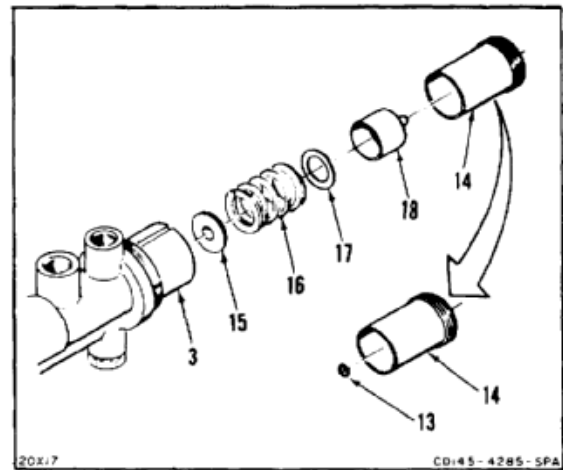

12. If bearing (19) was removed from rod end connector (20). Install bearing in end (TM 55-1520-322-24).
13. Install pin (21) in groove of housing (3).
14. Align groove in rod end connector (20) with pin (21) in housing (3). Install connector on housing.
15. Slide cap (22) over connector (20). Using strap wrench install cap on housing (3).

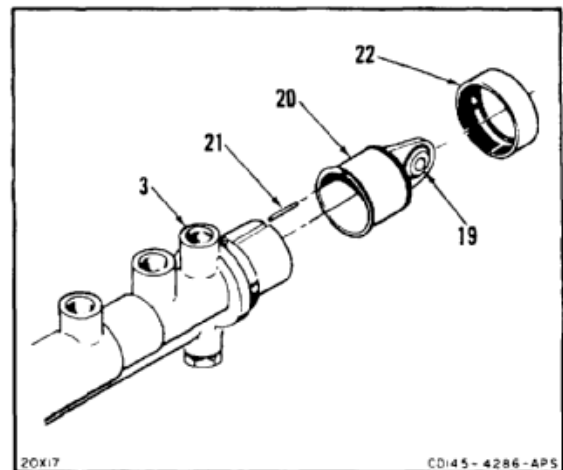

16. If data plate (23) was removed, install it on cap (22).
17. Install spacer (24), spring (25), and guide (26) on connector (20).
18. Have helper press down on guide (26) and install retaining ring (27) on connector (20).

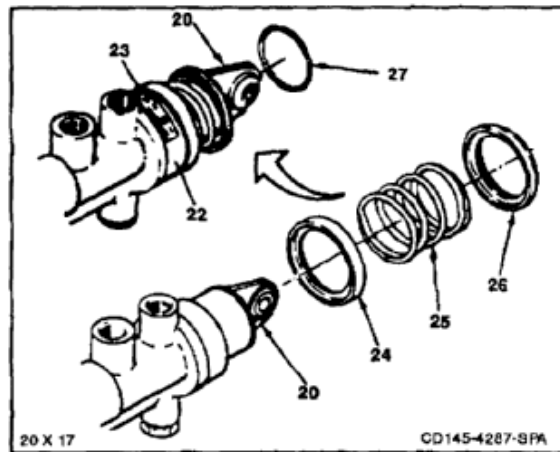

19. Install packing (28) on piston (29).
- 19.1. Install retaining ring (30) into ring groove in rod (33).
20. Install piston (29) and seat (31) on rod (33). Ensure that the large protruding lip of the seat is positioned to the bottom of housing (3) bore.
- 20.1. Install packing (32) on rod (33).

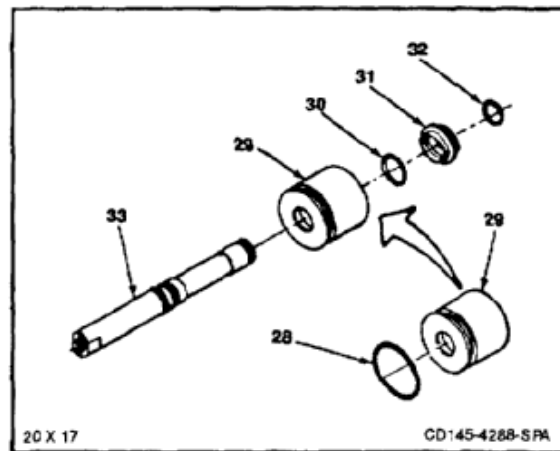

21. Install packing (34) on guide (35).
22. Install guide (35), spring (36), and rod (33) in housing (3).

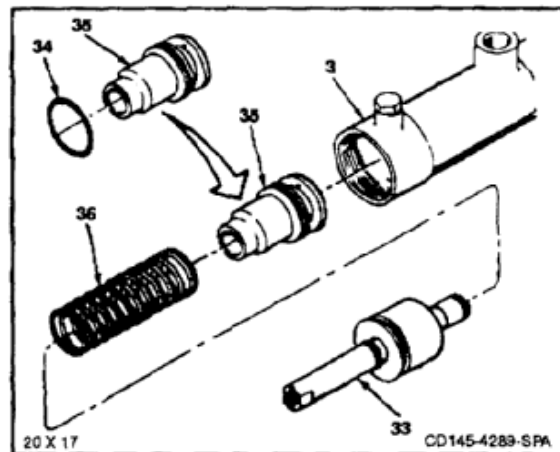

7-227 ASSEMBLE BRAKE MASTER CYLINDER (AVIM) (Continued)**7-227**

23. Install packings (37 and 38) in cap (39).
24. Install packing (40) on cap (39).
25. Install cap (39) on rod (33).
26. Have helper hold down on rod (33) and install end cap (39) in housing (3).
27. Lockwire cap (39) to housing (3). Use lockwire (E231).

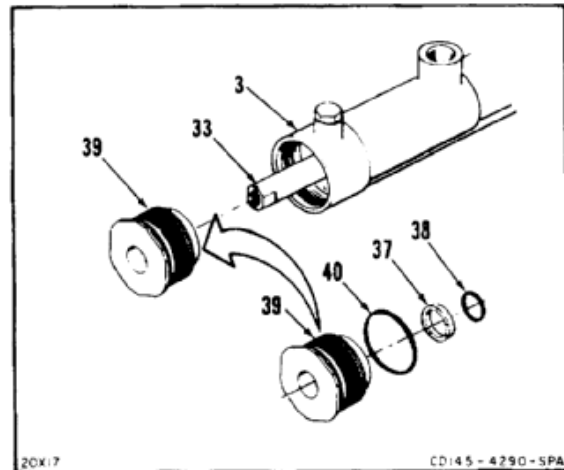

28. Hold housing (3), rod (33) down, and install pin (41) and spring (42) in rod.
29. Install nut (42) and washer (44) on rod end bearing (45).
30. Push spring (42) into rod (33) and install rod end bearing (45).

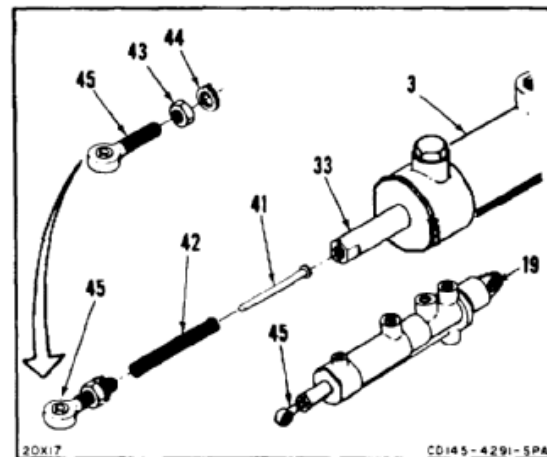
**INSPECT****FOLLOW-ON MAINTENANCE:**

Test brake master cylinder (Task 7-228).

END OF TASK

INITIAL SETUP

Applicable Configurations:

All

Tools:

- Hydraulic Repairer's Tool Kit, NSN 5180-00-323-4891
- Stopwatch
- Hydraulic Test Stand
- Hand Pump, 0 to 4500 psi
- Pressure Gage, 0 to 4500 psi
- Pressure Gage, 0 to 1500 psi
- Flowmeter
- Shutoff Valve (2)
- Flexible Hose, 1/4 Inch Diameter, 4500 psi
- Pressure Plugs
- Container, 2 Quart
- Brake Master Cylinder Test Fixture (APP E-19)
- Graduate 50 cc
- Weight, 25 Pounds
- Weight, 50 Pounds
- Weight, 94 Pounds
- Weight, 160 Pounds

Materials:

None

Personnel Required:

- Aircraft Pneudraulics Repairer (2)
- Inspector

References:

Appendix E

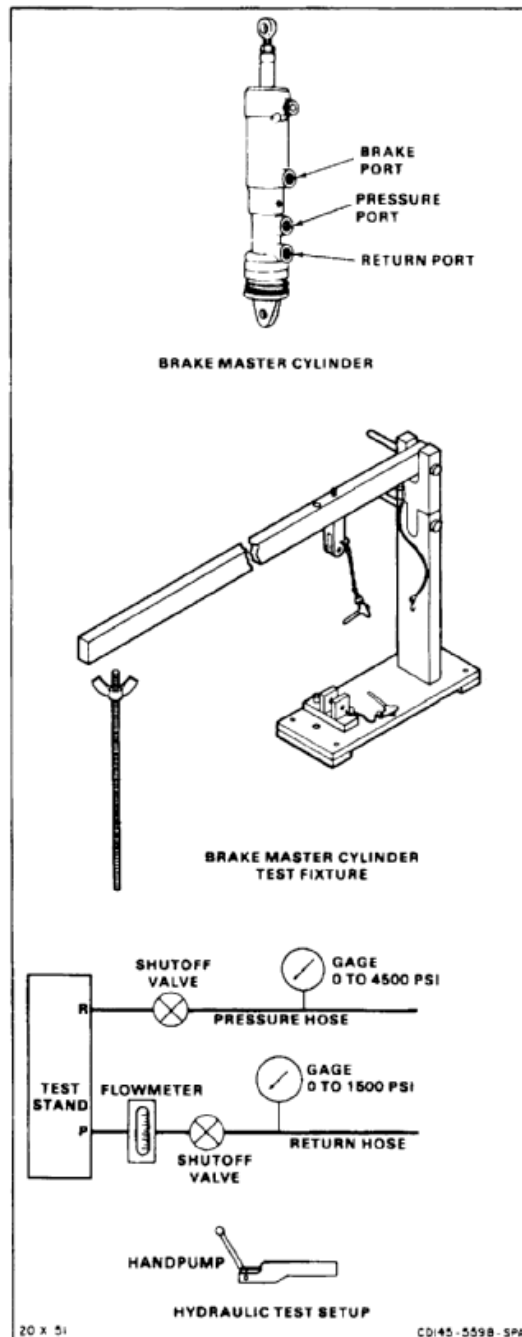

Equipment Condition:

Off Helicopter Task
Cylinder Installed In Crash Box

General Safety Instructions:

WARNING

Use suitable crash box to shield personnel and equipment in case of failure during test.

WARNING

Hydraulic fluid (E199) is toxic. It can irritate skin and cause burns. Avoid inhaling. Use only with adequate ventilation. Avoid contact with skin, eyes, or clothing. In case of contact, immediately flush skin or eyes with water for at least **15 minutes**. Get medical attention for eyes.

WARNING

Hydraulic fluid ejected under pressure can cause injury to personnel. Hydraulic fluid sprayed into the air is a fire hazard.

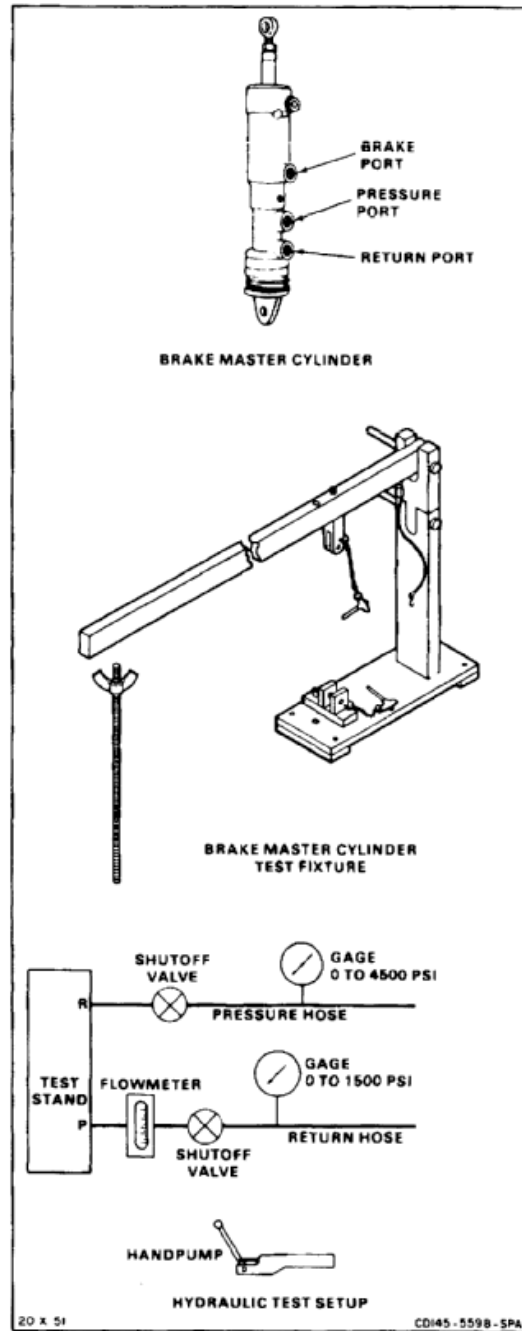

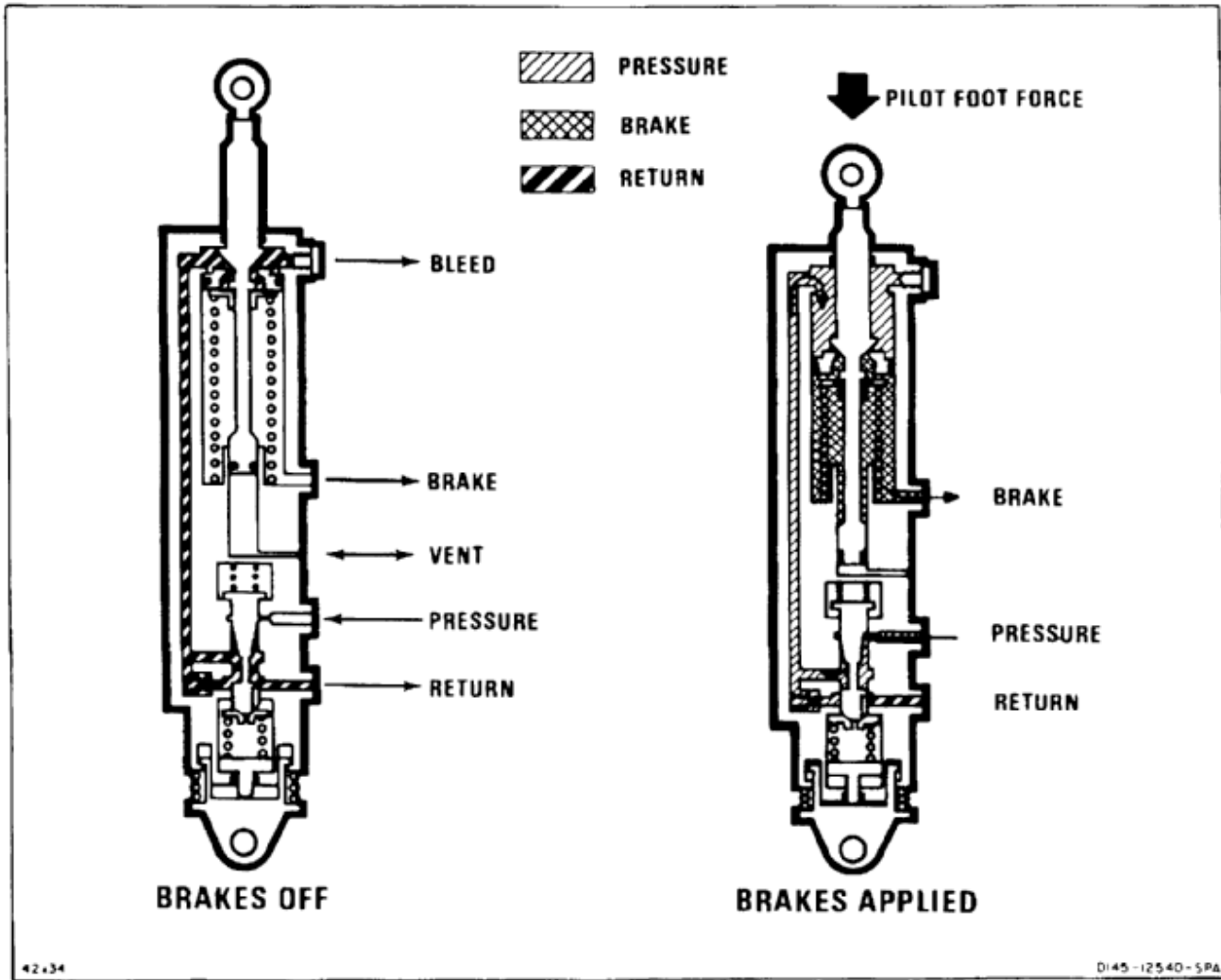

42x34

D145-12540-5PA

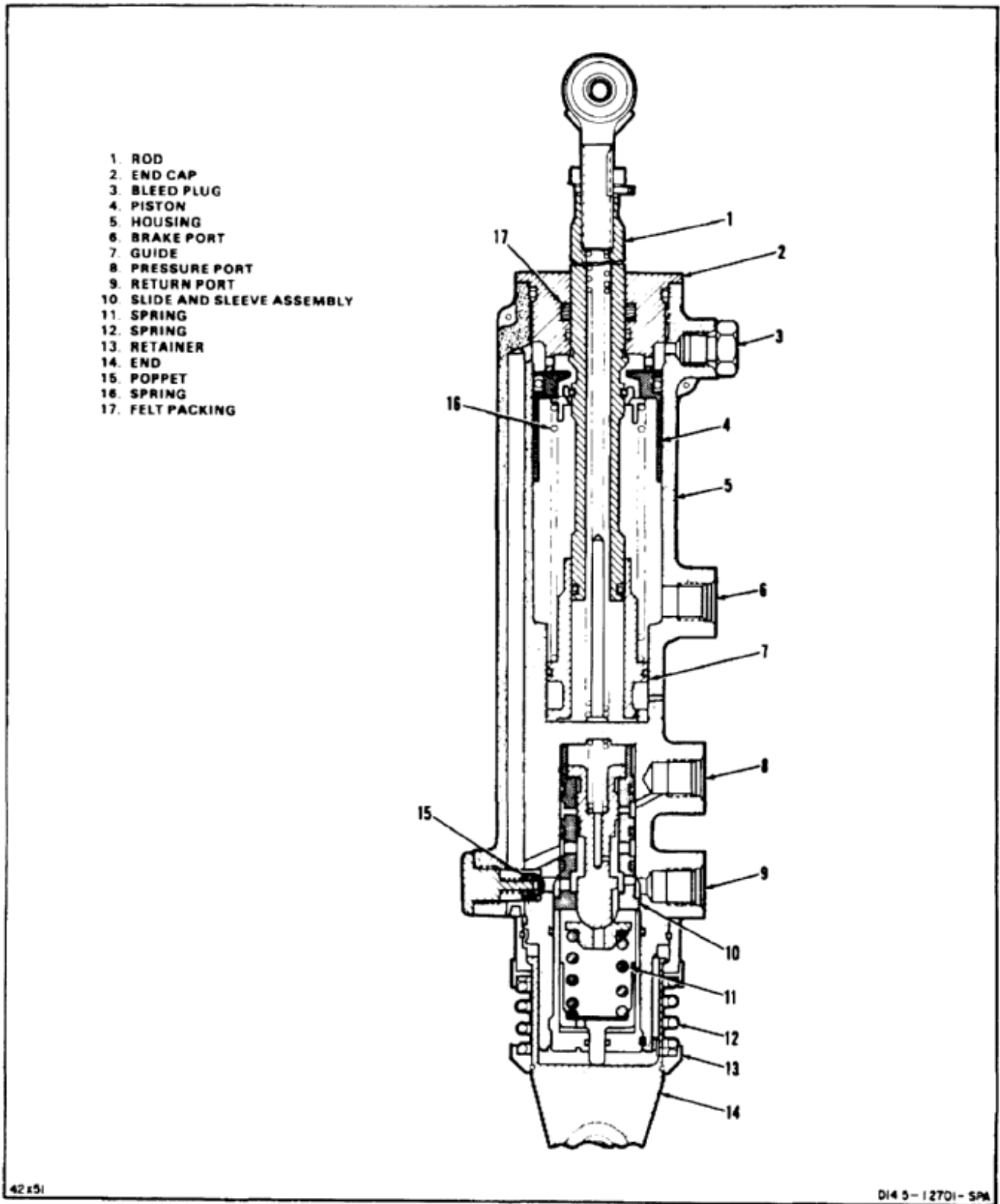

1. Position brake master cylinder (1) in test fixture (2) and install two pins (3).
2. Connect pressure hose (4) to PRESS port (5). Remove pressure plugs from BRAKE port (6) and RETURN port (7).

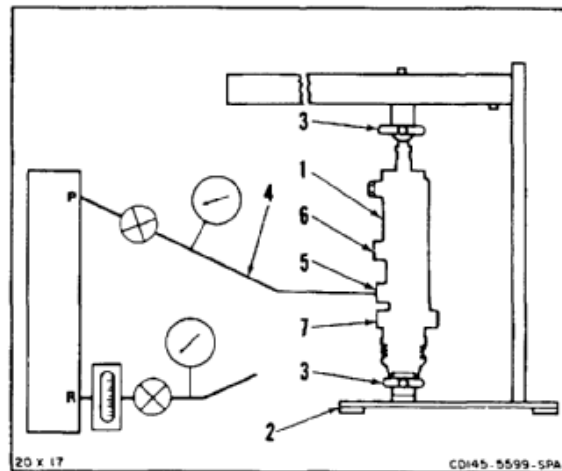

3. Adjust handle (8) until distance from center of bearing (9) to center of bearing (10) is **13 inches (13 inch position)**.
4. Check that shutoff valves (11 and 12) are closed.
5. Hold handle (8) in **13 inch** position.
6. Open shutoff valve (11). Apply **25 psi** to PRESS port (5). Maintain pressure for **3 minutes**.
7. Check cylinder (1) for leaks. There shall be no external leaks. Internal leaks from ports (6 and 7) shall not exceed **2 drops per minute**.
8. Increase pressure at PRESS port (5) to **4500 psi**. Maintain pressure for **3 minutes**.
9. Check cylinder (1) for leaks. There shall be no external leaks. Internal leaks from ports (6 and 7) shall not exceed **30 drops per minute**.

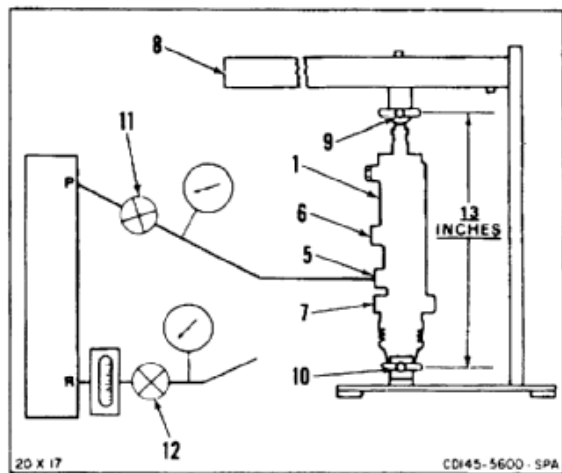

10. Close shutoff valve (11) to reduce pressure to **0 psi**.
11. Disconnect hose from PRESS port (5).
12. Install rod (13) and thumb screw (14) on test fixture (2).

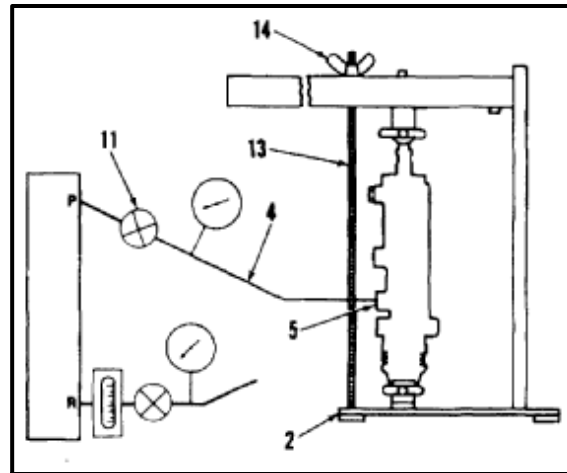

13. Connect hose (4) to BRAKE Port (6).
14. Adjust handle (8) until distance from center of rod end bearing (9) to center of bearing (10) is **12.25 inches (12.25 inch position)**. Tighten thumb screw (14).
15. Open shutoff valve (11) and apply **10 psi** to BRAKE Port (6). Maintain pressure for **1 minute**.
16. Check cylinder (1) for leaks. There shall be no external leaks. Internal leaks from ports (5 and 7) shall not exceed **2 drops per minute**.
17. Increase pressure at BRAKE port (6) to **1950 psi**. Maintain pressure for **1 minute**.
18. Check cylinder (1) for leaks. There shall be no external leaks. Internal leaks from ports (5 and 7) shall not exceed **2 drops per minute**.

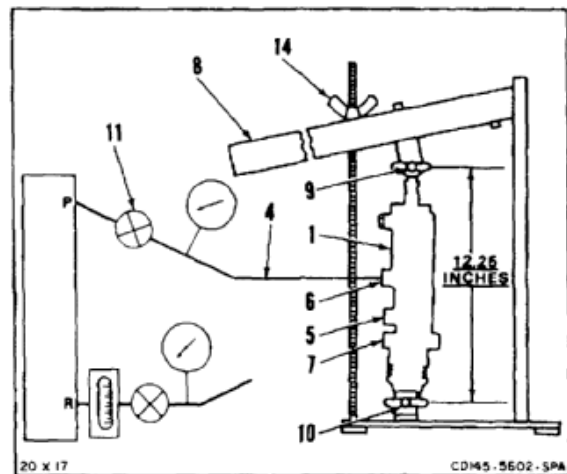

19. Reduce pressure at BRAKE port (6) to **10 psi**.
20. Hold handle (8) and remove thumb screw (14).
21. Position container (15) under RETURN port (7).
22. Release handle (8) and check RETURN port (7). When cylinder (1) extends to **13 inch** position, hydraulic fluid shall flow from RETURN port.
23. Close shutoff valve (11) to reduce pressure to **0 psi**.

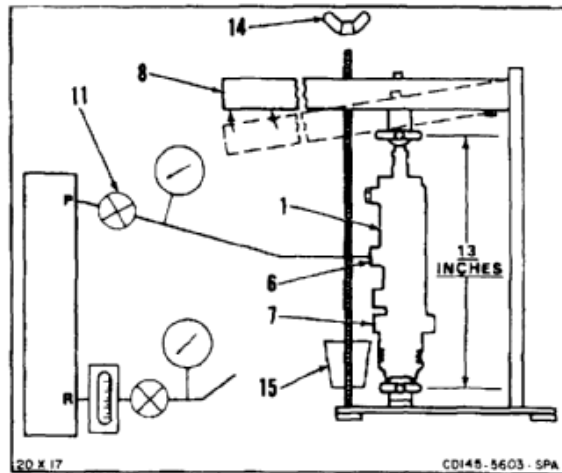

24. Disconnect hose (4) from BRAKE port (6).
25. Install pressure plugs in ports (5 and 6).
26. Connect hose (4) to RETURN port (7).
27. Adjust handle (8) until distance from center of rod end bearing (9) to center of bearing (10) is **11.5 inches (11.5 inch position)**. Tighten thumb screw (14).
28. Open shutoff valve (11) and apply **25 psi** to RETURN port (7). Maintain pressure for **2 minutes**.
29. Check cylinder (1) for leaks. There shall be no external leaks.
30. Increase pressure to RETURN port (7) to **1950 psi**. Maintain pressure for **2 minutes**.
31. Check cylinder (1) for leaks. There shall be no external leaks.
32. Close shutoff valve (11) to reduce pressure to **0 psi**.

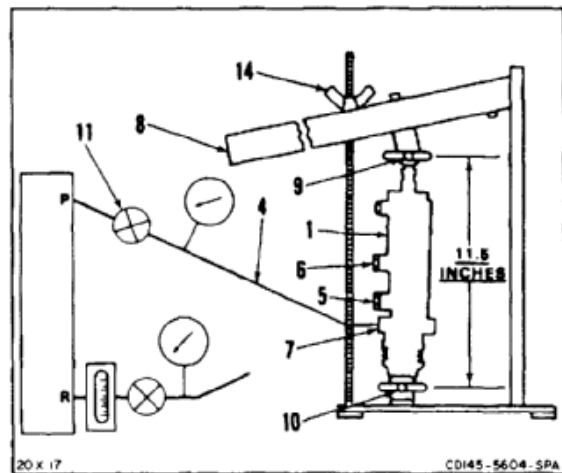

33. Remove rod (13) and thumb screw (14) from test fixture (2).
34. Remove pressure plugs from ports (5 and 6).
35. Disconnect hose (4) from RETURN port (7).
36. Connect hose (4) to PRESS port (5).
37. Connect return hose (16) to BRAKE port (6).
38. Make sure valve (17) is closed.

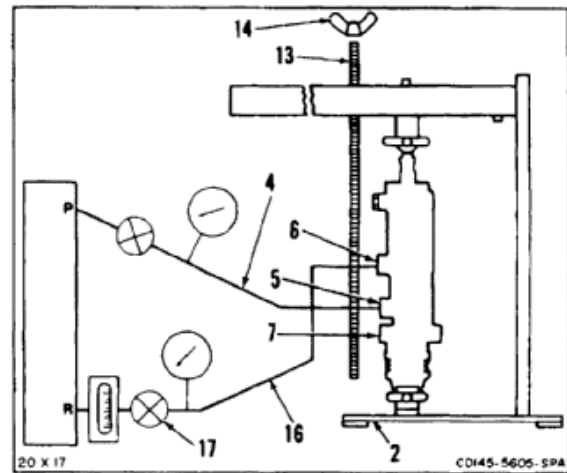

39. Open shutoff valve (11). Apply **4500 psi** to PRESS port (5).
40. With aid of helper, attach **160 pound** weight (18) to handle (8) of test fixture (2).
41. Open shutoff valve (17) until bearings (9 and 10) are **12.25 inch** apart. Close shutoff valve (17).
42. Hold handle (8) in **12.25 inch** position for **3 minutes**.
43. Check cylinder (1) for leaks. There shall be no external leaks
44. Close shutoff valve (11) to reduce pressure to **0 psi**.
45. With aid of helper, remove **160 pound** weight (18) from handle (8).

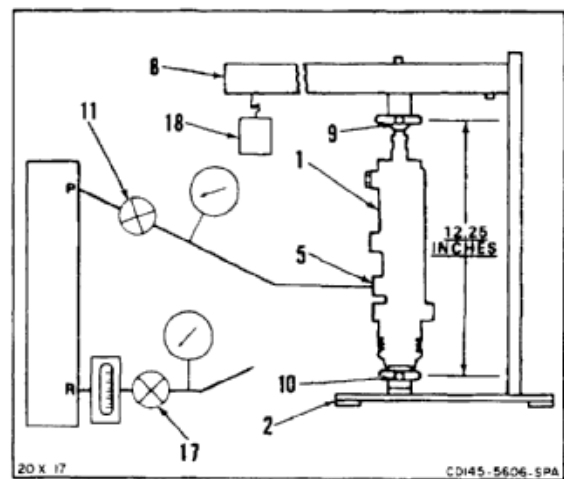

46. Open shutoff valve (11). Apply **3000 psi** to PRESS port (5).
47. Attach **25 pound** (19) weight to handle (8).
48. Position graduate (20) under RETURN port (7).
49. After **1 minute**, check RETURN port (7) for leaks. Leaks shall not exceed **32 cc per minute**.
50. Check pressure gage (21) for **2 minutes**. Gage shall read **320 to 575 psi**. Pressure reading shall not vary more than **30 psi** during **2 minutes**.
51. Remove **25 pound** (19) weight from handle (8).

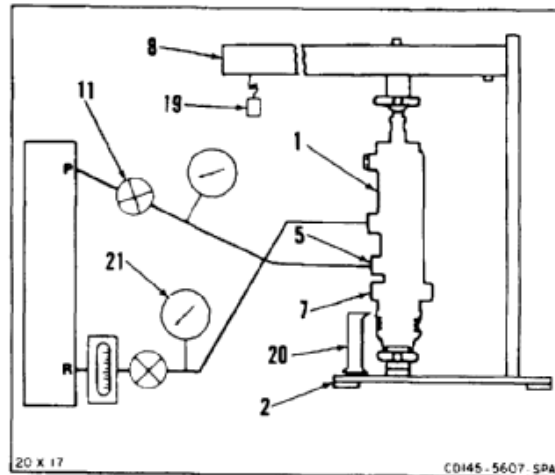

52. With aid of helper, attach **94 pound** weight (22) to handle (8). Maintain **3000 psi** pressure.
53. After **1 minute**, check RETURN port (7) for leaks. Leaks shall not exceed **32 cc per minute**.
54. Check pressure gage (21) for **2 minutes**. Gage shall read **935 to 1090 psi**. Pressure reading shall not vary more than **30 psi** during **2 minutes**.
55. With aid of helper, remove **94 pound** weight (22) from handle (8). Check cylinder (1). Cylinder shall extend until bearings (9 and 10) are **13 inches** apart.
56. Close shutoff valve (11) to reduce pressure to **0 psi**.
57. Remove graduate (20).

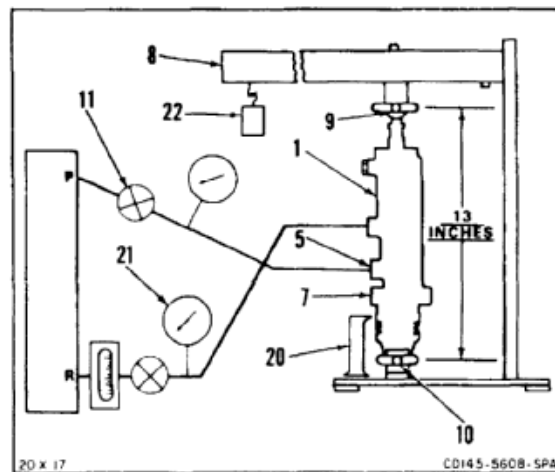

- 58. Connect handpump pressure hose (23) to RETURN port (7).
- 59. Open shutoff valve (11). Apply **3000 psi** to PRESS port (5).
- 60. Apply **50 psi** to RETURN port (7).

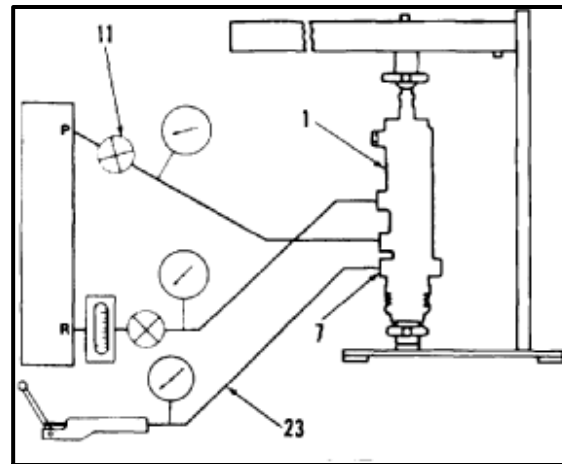

- 61. With aid of helper, attach **50 pound weight** (24) to handle (8).
- 62. Open shutoff valve (17) and bleed fluid from cylinder (1) until bearings (9 and 10) are **11.5 inch** apart. Close shutoff valve (17).
- 63. Check pressure gage (21). Gage shall read **725 to 825 psi**.
- 64. Push up handle (8) until bearings (9 and 10) are **13 inches** apart.
- 65. Check pressure gage (21). Gage shall read **790 to 950 psi**.
- 66. With aid of helper, remove **50 pound weight** (24) from handle (8).

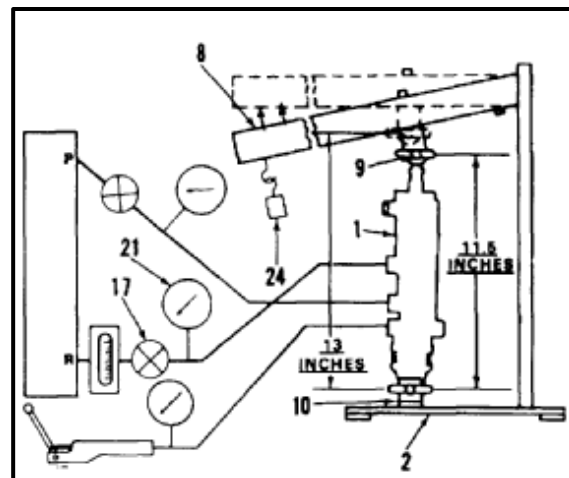

NOTE

Cylinder is cycled by moving cylinder between **13 inch** position and **11.5 inch** position.

- 67. Cycle cylinder (1) **25 times**.
- 68. After **25 cycles** check cylinder (1). External leakage shall not exceed **1 drop**. There shall be no chattering or vibration.

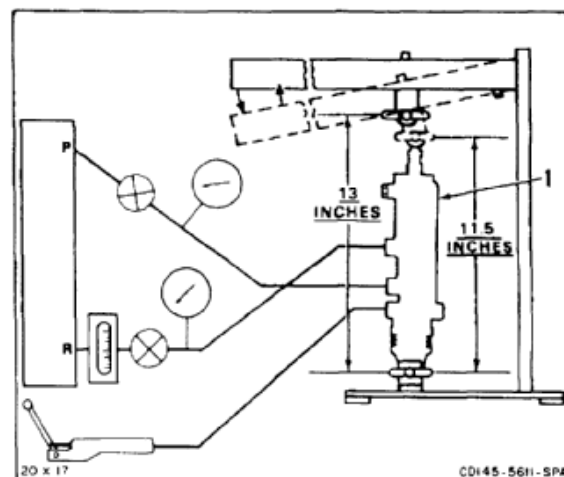

69. Open shutoff valve (17).
70. Pull handle (8) down until bearings (9 and 10) are **11.5 inches** apart.
71. Check BRAKE port (6). There shall be a steady flow of fluid from BRAKE port (6).
72. Release handle (8).
73. Close shutoff valve (11) to reduce pressure at PRESS Port (5) to **0 psi**.

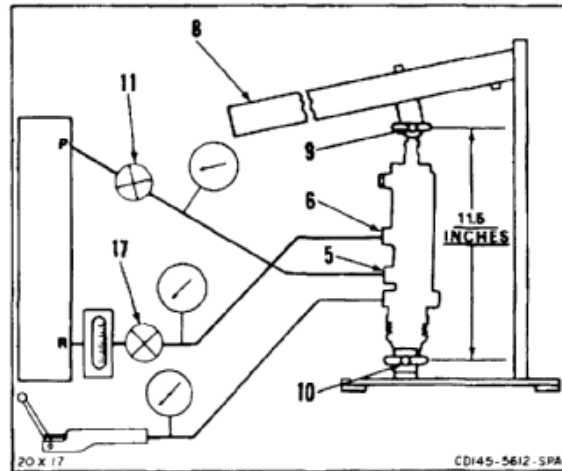

74. Reduce pressure at RETURN port (7) to **0 psi**.
75. Remove hose (4) from PRESS port (5).
76. Remove hose (23) from RETURN port (7).
77. Remove return hose (16) from BRAKE port (6).
78. Remove two pins (3) and cylinder (1) from test fixture (2).

FOLLOW-ON MAINTENANCE:

None

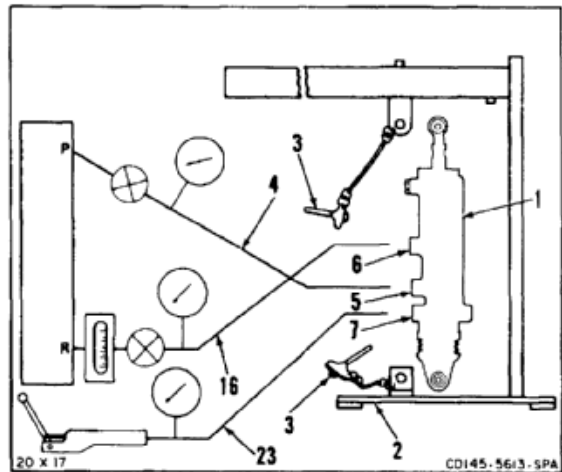

END OF TASK

INITIAL SETUP

Applicable Configurations:

All

Tools:

Aircraft Mechanic's Tool Kit, NSN 51 80-00-3234692
Torque Wrench, 30 to 150 Inch-Pounds

Materials:

None

Parts:

Preformed Packings
Cotter Pins
Washers

Personnel Required:

Medium Helicopter Repairer
Inspector

References:

TM 55-1520-240-23P

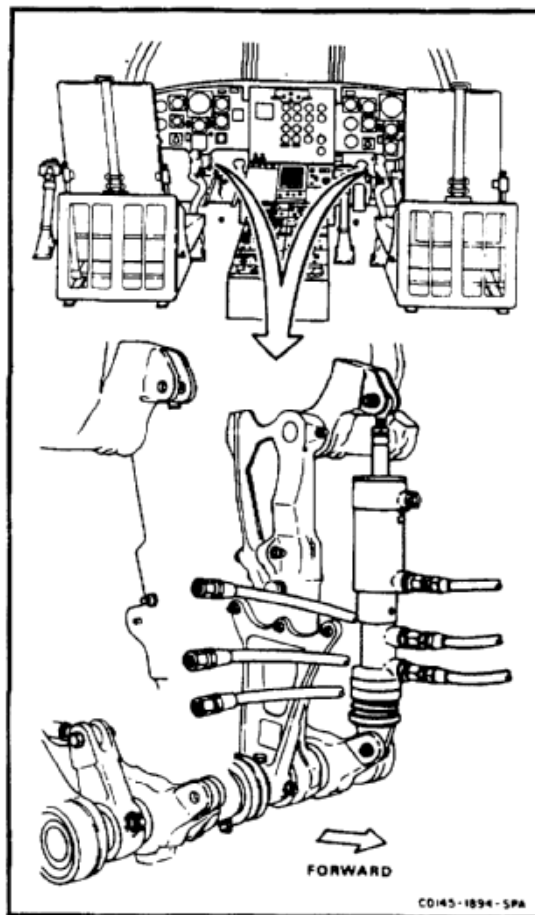

NOTE

Procedure is same to install pilot's or copilot's outboard cylinder. Pilot's cylinder is shown here.

1. Install three washers (1), packings (2), and elbows (3) in cylinder (4). Do not tighten nuts (5).
- 1.1. Install scupper (5.1) on cylinder (4).

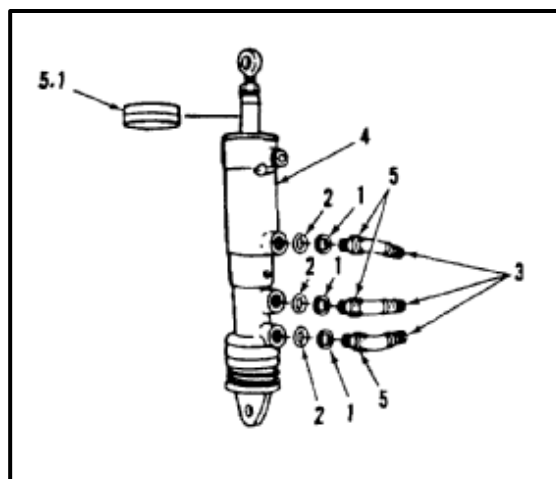

2. Position cylinder (4) in upper mount (6).
3. Install bolt (7) with head outboard washer (8), washer (9), and nut (10). Torque nut **30 to 60 inch-pounds**. Install cotter pin (11).

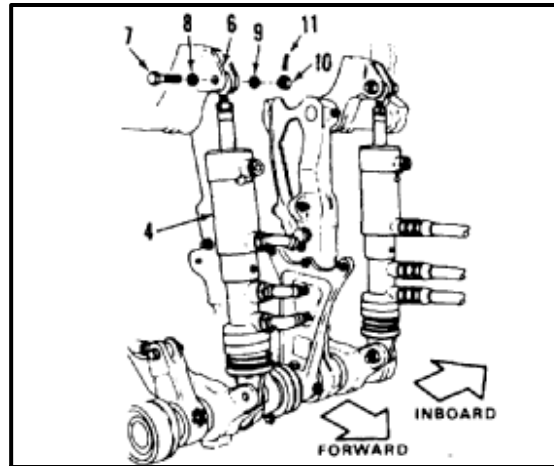

4. Position cylinder (4) in lower mount (12).
5. Install washer (13), bolt (14) with head outboard washer (15), and nut (16). Torque nut **30 to 60 inch-pounds**. Install cotter pin (17).

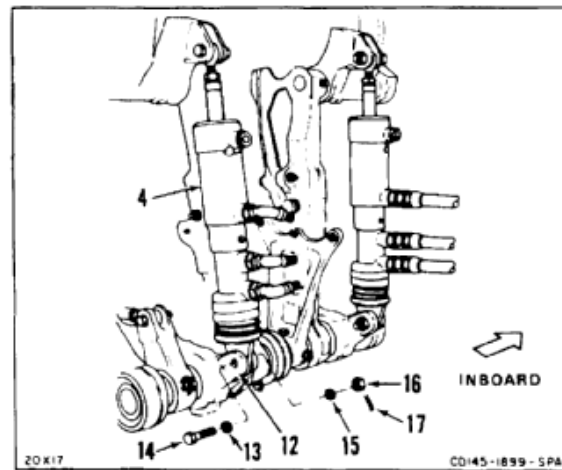

6. Connect BRAKE hose (18). Remove tag.
7. Connect PRESS hose (19). Remove tag.
8. Connect RET hose (20). Remove tag.
9. Tighten three nuts (5).

INSPECT

FOLLOW-ON MAINTENANCE:

Bleed brake hydraulic system (Task 7-330).
 Perform operational check of brake master cylinder (TM 55-1520-240-T).

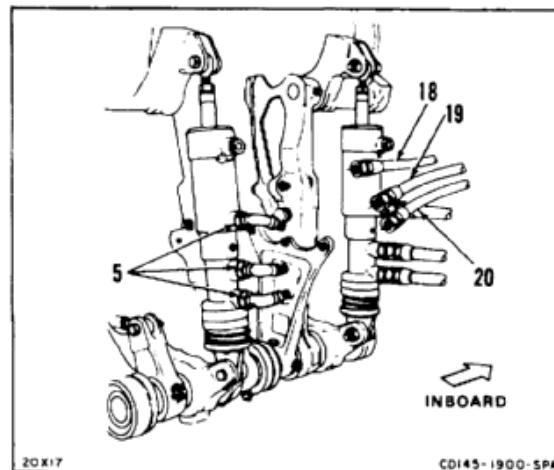

END OF TASK

INITIAL SETUP

Applicable Configurations:

All

Tools:

Aircraft Mechanic's Tool Kit, NSN 5180-00-323-4692
Torque Wrench, 30 to 150 Inch-Pounds

Materials:

None

Parts:

Preformed Packings
Cotter Pins

Personnel Required:

Medium Helicopter Repairer
Inspector

References:

TM 55-1520-240-23P

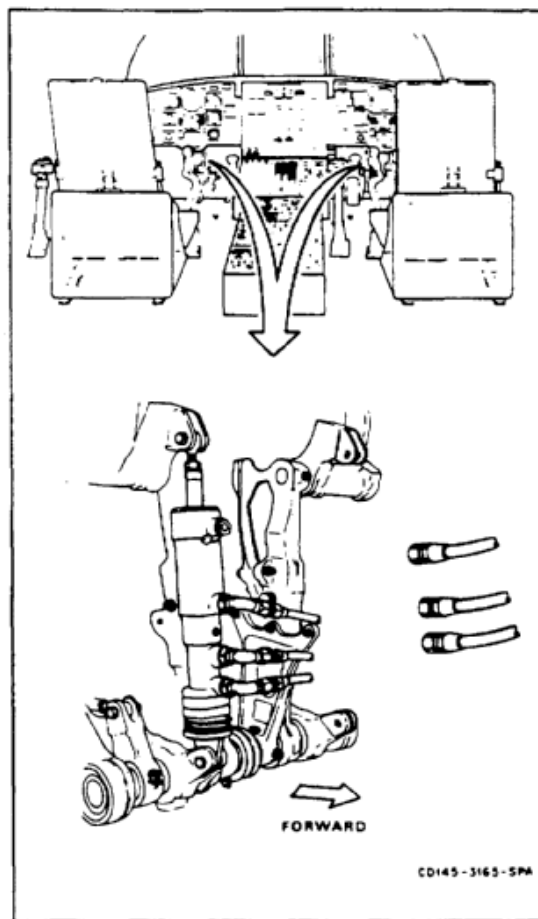

NOTE

Procedure is same to install pilot's or copilot's inboard cylinder. Pilot's inboard cylinder is shown here.

1. Install three packings (1) and nipples (2) in cylinder (3).
- 1.1. Install scupper (3.1) on cylinder (4).

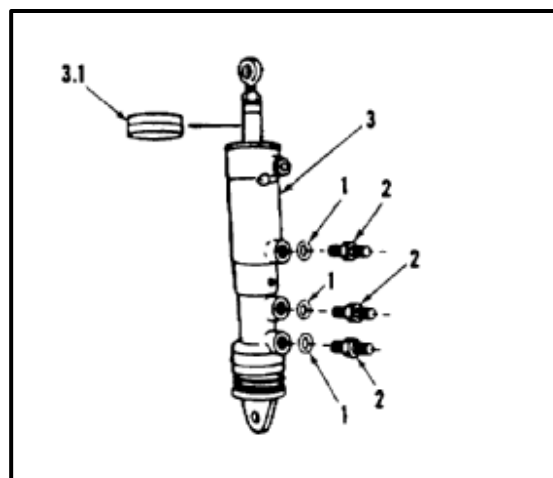

2. Position cylinder (3) in upper mount (4).
3. Install washer (5), bolt (6) with head inboard, washer (7), and nut (8). Torque nut **30 to 60 inch-pounds**. Install cotter pin (9).

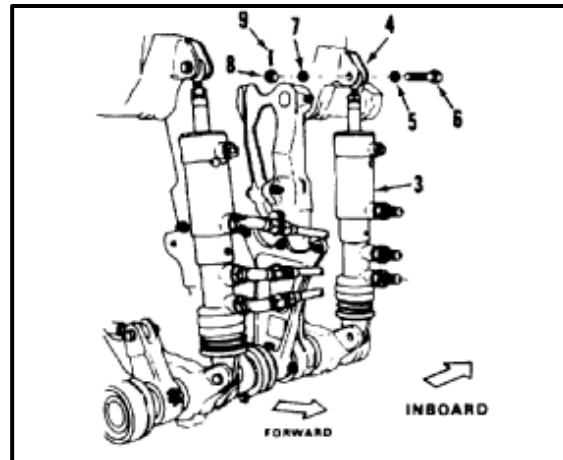

4. Position cylinder (3) in lower mount (10).
5. Install washer (11), bolt (12) with head inboard, washer (13), and nut (14). Torque nut **30 to 60 inch-pounds**. Install cotter pin (15).

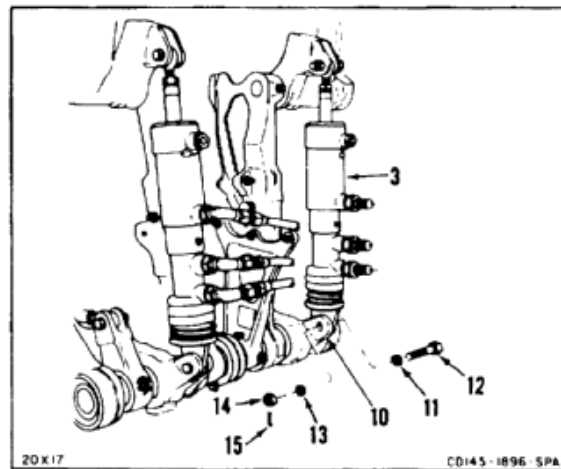

6. Connect BRAKE hose (16). Remove tag.
7. Connect PRESS hose (17). Remove tag.
8. Connect RET hose (18). Remove tag.

FOLLOW-ON MAINTENANCE:

Bleed brake hydraulic system (Task 7-330).
 Perform operational check of brake master cylinder (TM 55-1520-240-T).

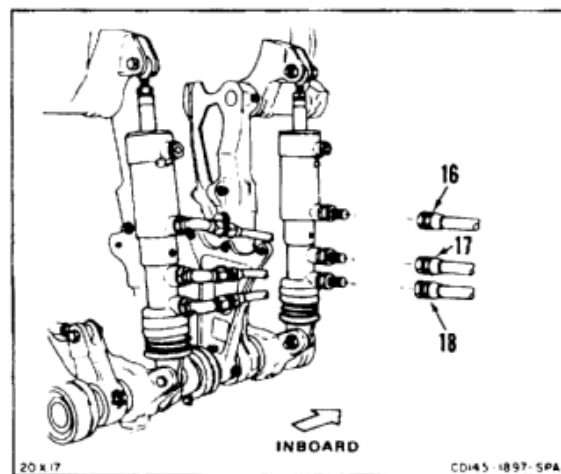

END OF TASK

7-870

7-231 REMOVE BRAKE TRANSFER VALVE

7-231

INITIAL SETUP**Applicable Configurations:**

All

Tools:

Aircraft Mechanic's Tool Kit, NSN 51 80-00-323-4692

Materials:Cloths (E135)
Gloves (E186)**Personnel Required:**

Medium Helicopter Repairer (2)

Equipment Condition:Battery Disconnected (Task 1-39)
Electrical Power Off
Hydraulic Power Off
Utility Hydraulic System Depressurized (Task 7-135.1)
Pilot's and Copilot's Seats Fully Aft (Task 2-115)**General Safety Instructions:****WARNING**

Hydraulic fluid (E199) is toxic. It can irritate skin and cause burns. Avoid inhaling. Use only with adequate ventilation. Avoid contact with skin, eyes, or clothing. In case of contact, immediately flush skin or eyes with water for at least **15 minutes**. Get medical attention for eyes.

WARNING

Hydraulic fluid ejected under pressure can cause injury to personnel. Hydraulic fluid sprayed into the air is a fire hazard.

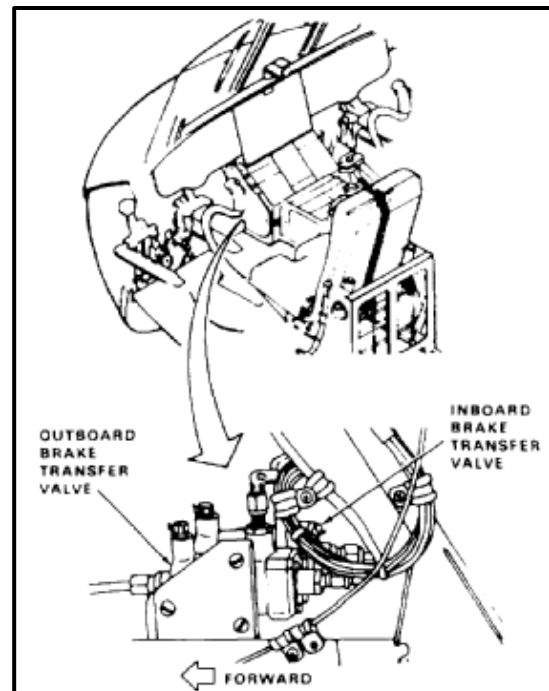

NOTE

To remove outboard brake transfer valve, perform steps 1 thru 3. To remove inboard brake transfer valve, perform steps 4 thru 6.

OUTBOARD VALVE

1. Operate cockpit foot brake pedals ten times to relieve system pressure.
- 1.1. Disconnect three hydraulic tubes (1) from valve (2). Use cloths (E135) for spilled fluid. Use gloves (E186).
2. Remove three screws (3), six washers (4), and three nuts (5). Remove valve (2).

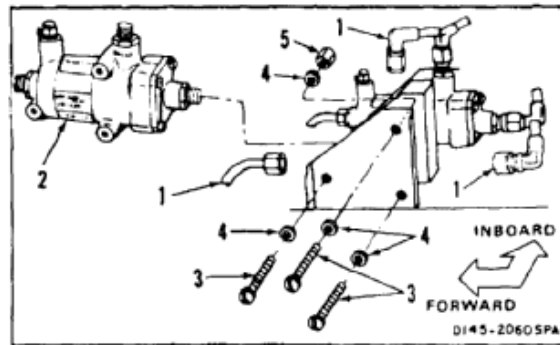

3. Remove three nipples (6) and packings (7) from valve (2).

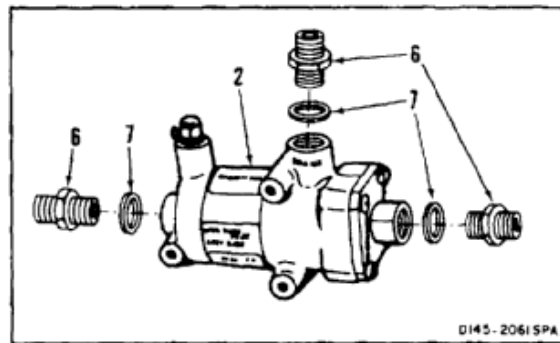

INBOARD VALVE

4. Operate cockpit foot brake pedals ten times to relieve system pressure.
- 4.1. Disconnect three hydraulic tubes (8) from valve (9). Use cloths (E135) for spilled fluid. Use gloves (E186).
5. Remove three screws (10), six washers (11), and three nuts (12). Have helper hold screw heads from turning when removing nuts. Use screwdriver.
6. Remove valve (9).

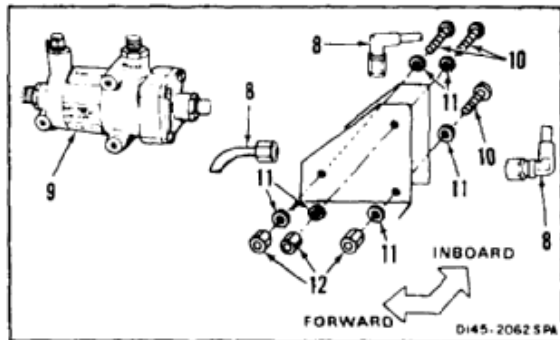

7. Remove three nipples (13) and packings (14).

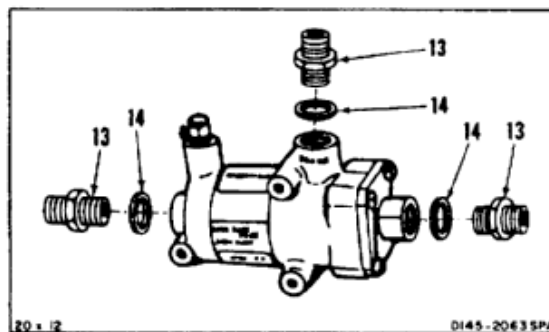

FOLLOW-ON MAINTENANCE:

None

END OF TASK

INITIAL SETUP

Applicable Configurations:

All

Tools:

Hydraulic Repairer's Tool Kit, NSN 5180-00-323-4891
Strap Wrench

Materials:

None

Personnel Required:

Aircraft Pneudraulics Repairer

Equipment Condition:

Off Helicopter Task

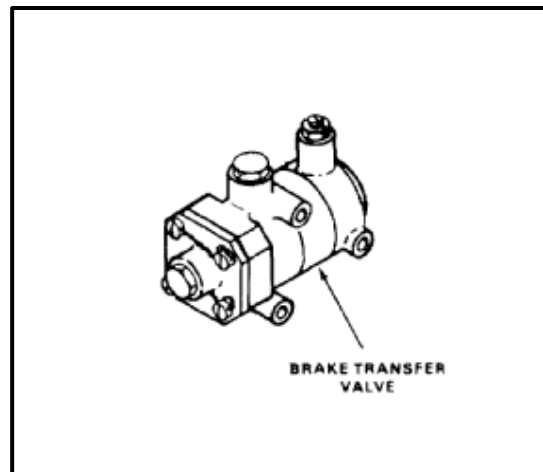

1. Remove lockwire, screw (1), and bleeder valve (2) from body (3).

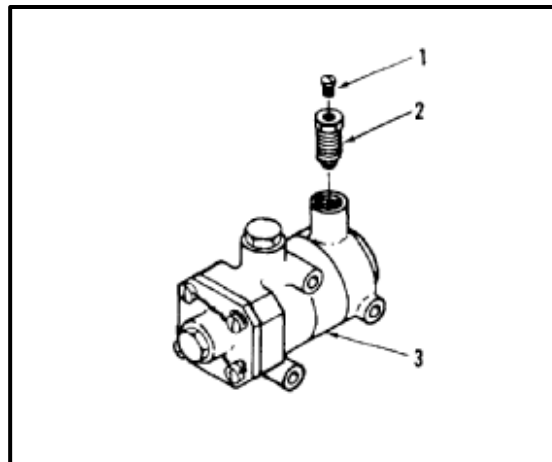

WARNING

Brake transfer valve is spring-loaded. Remove cap carefully to prevent injury to personnel.

2. Remove lockwire, four screws (4), cap (5), and packing (6) from body (3).
3. Remove spring (7) and piston (8) from body (3). Remove packing (9) from piston (8).

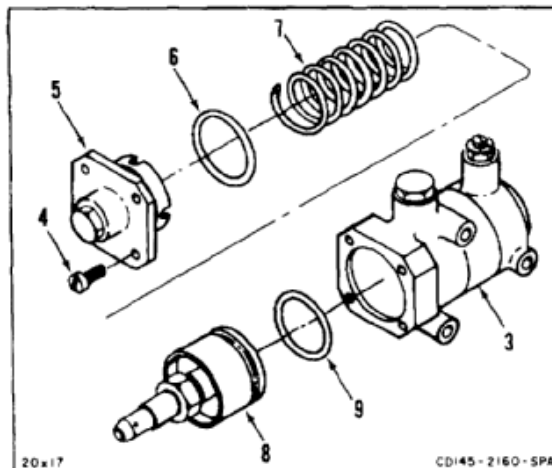

7-232 DISASSEMBLE BRAKE TRANSFER VALVE (AVIM) (Continued)

7-232

4. Hold piston (8) with strap wrench (10) and remove cap (11).
5. Remove guide (12), poppet (13), spring (14), and pin (15) from piston (8).

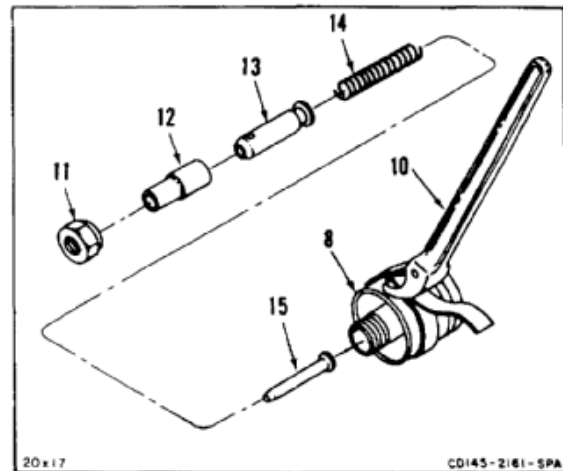
***FOLLOW-ON MAINTENANCE:***

None

END OF TASK

INITIAL SETUP

Applicable Configurations:

All

Tools:

- Technical Inspection Tool Kit, NSN 5180-00-323-5114
- Torque Wrench, 0 to 15 Inch-Ounces
- Torque Wrench, 5 to 50 Inch-Pounds
- Outside Micrometer Caliper Set
- Hole Gage, 0.300 to 0.400 Inch
- Hole Gage, 0.400 to 0.500 Inch
- Spring Compression Tester

Materials:

None

Personnel Required:

Inspector

References:

Task 7-1.1

Equipment Condition:

- Off Helicopter Task
- Brake Transfer Valve Disassembled (Task 7-232)

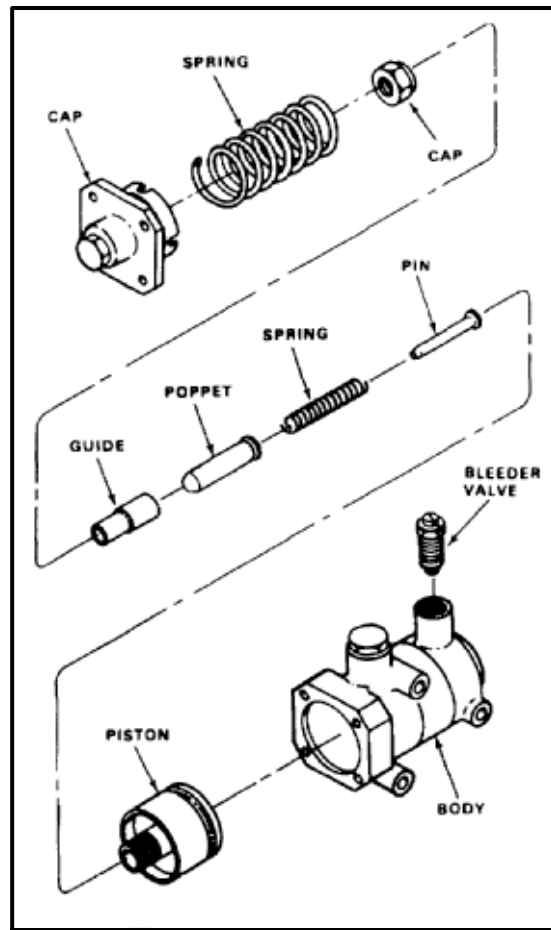

NOTE

General inspection criteria (Task 7-1.1) for obvious damage applies unless otherwise stated.

Inspection steps cover parts that are subject to wear.

1. Measure diameter of bore (1) in body (2). Diameter shall not be more than **1.501 inch**.
2. Measure bore (3) and outside diameter of piston (4). Bore shall not be more than **0.469 inch**. Outside diameter shall not be less than **1.497 inches**.

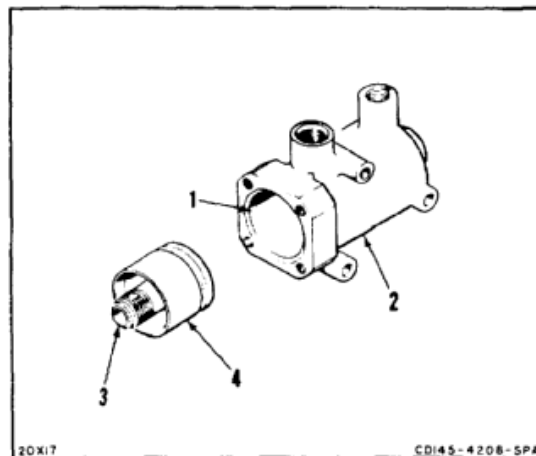

3. Measure diameter of poppet (5). Diameter shall not be less than **0.308 inch**. Rounded end of poppet shall have no nicks or scratches.
4. Measure bore (6) and large outside diameter of guide (7). Bore shall not be more than **0.310 inch**. Diameter shall not be less than **0.467 inch**.

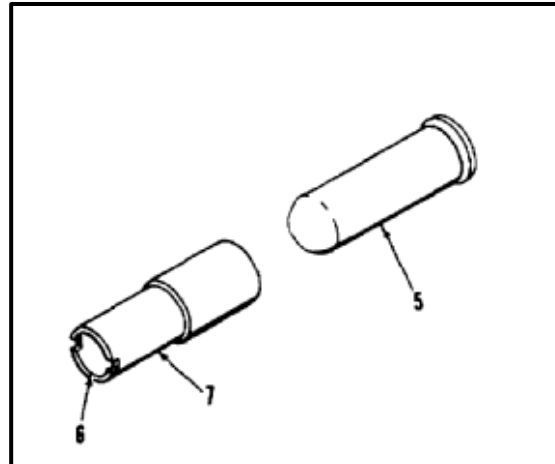

5. Measure free length of spring (8). Free length shall be **6.63 to 6.87 inches**.
6. Install spring (8) in compression tester (9).
7. Compress spring (8) to **2.440 inches**. Force needed to compress spring shall be **11 to 13 pounds**.
8. Remove spring (8) from tester (9).

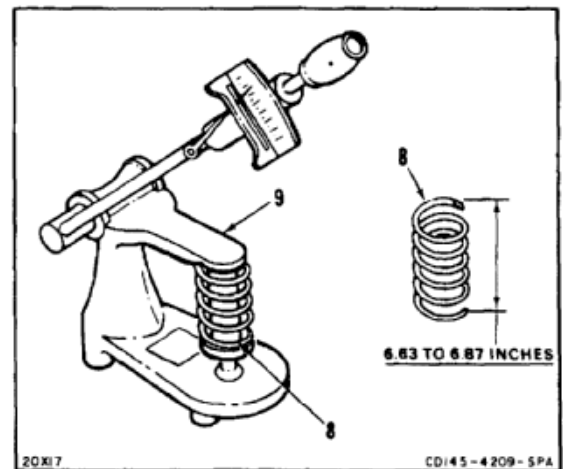

9. Measure free length of spring (10). Free length shall be **3.09 to 3.21 inches**.
10. Install spring (10) in tester (9).
11. Compress spring (10) to **2.312 inches**. Force needed to compress spring shall be **5 to 7 ounces**.
12. Remove spring (10) from tester (9).

FOLLOW-ON MAINTENANCE:

None

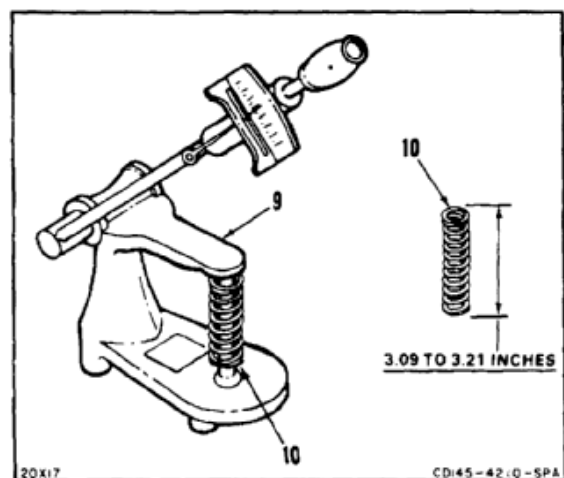

END OF TASK

INITIAL SETUP

Applicable Configurations:

All

Tools:

Hydraulic Repairer's Tool Kit, NSN 5180-00-323-4891
Strap Wrench

Materials:

Lockwire (E231)

Parts:

Preformed Packings

Personnel Required:

Aircraft Pneudraulics Repairer
Inspector

References:

TM 55-1520-240-23P

Equipment Condition:

Brake Transfer Valve Inspection (Task 7-233)

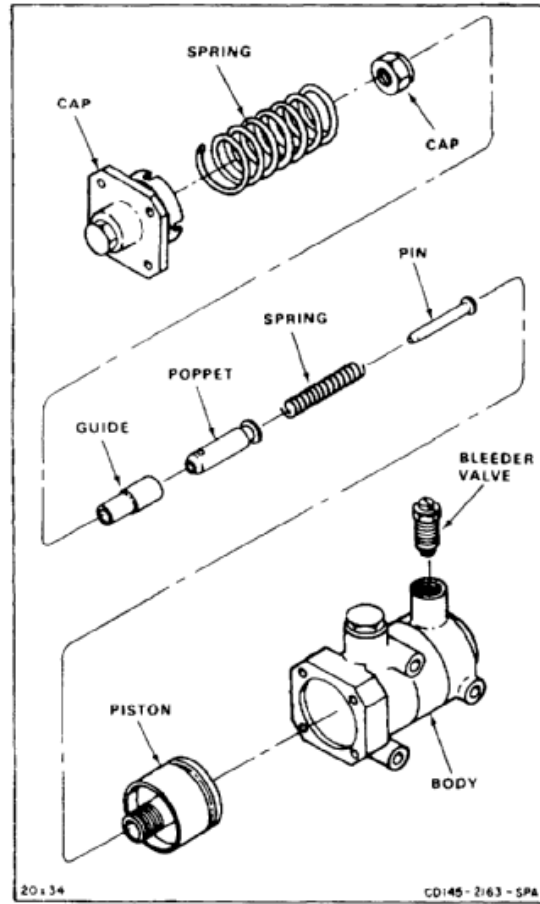

1. Install bleeder valve (1) and screw (2) in body (3).

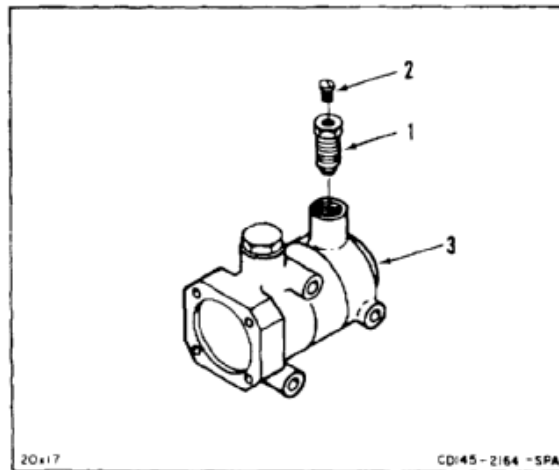

2. Hold piston (4) with strap wrench (5).
3. Install pin (6), spring (7), poppet (8), guide (9), and cap (10) in piston (4).

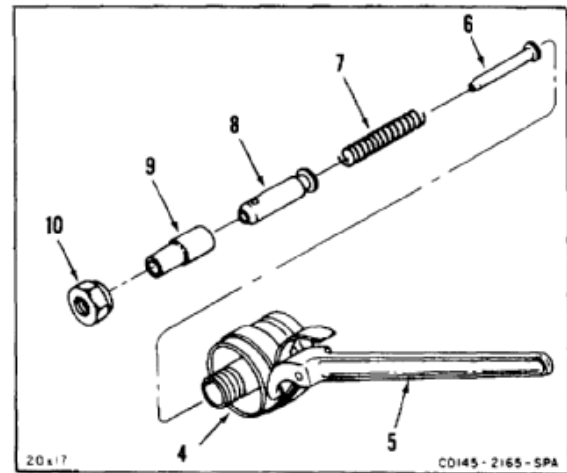

4. Install packing (11) on piston (4). Install piston (4) in body (3).
5. Install spring (12) in body (3).
6. Install packing (13) on cap (14). Position cap and packing on body (3).
7. Install four screws (15) in cap (14). Lockwire screws. Use lockwire (E231).

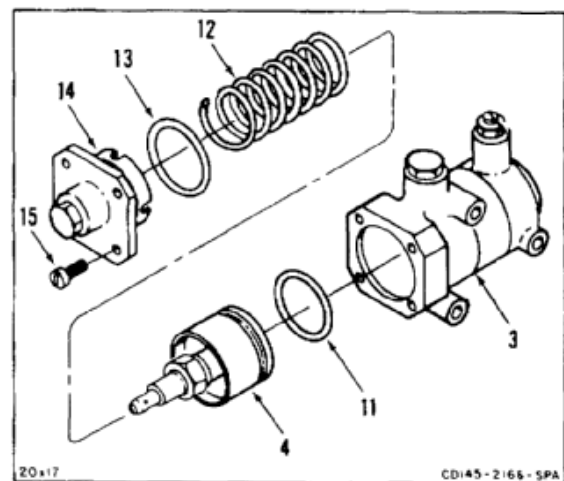

INSPECT

FOLLOW-ON MAINTENANCE:

Test brake transfer valve (Task 7-235).

END OF TASK

INITIAL SETUP

Applicable Configurations:

All

Tools:

- Hydraulic Repairer's Tool Kit, NSN 5180-00-323-4891
- Hydraulic Test Stand
- Flexible Hoses, 1/4 Inch OD Capable of 0 to 3000 psi
- Shutoff Valve (5)
- Pressure Gage, 0 to 3000 psi (2)
- Nylon Rod, 1/4 Inch X 6 Inches
- Container, 2 Quart
- Graduate Cylinder, 0 to 50 cc

Materials:

- Cloths (E120)
- Hydraulic Fluid (E199)
- Lockwire (E231)
- Gloves (E186)

Personnel Required:

- Aircraft Pneudraulics Repairer
- Inspector

Equipment Condition:

- Off Helicopter Task
- Hydraulic Test Setup
- Brake Transfer Valve Installed in Crash Box

General Safety Instructions:

WARNING

Brake transfer valve must be installed in crash-proof box before test is performed. Otherwise, injury to personnel can occur.

WARNING

Hydraulic fluid (E199) is toxic. It can irritate skin and cause burns. Avoid inhaling. Use only with adequate ventilation. Avoid contact with skin, eyes, or clothing. In case of contact, immediately flush skin or eyes with water for at least **15 minutes**. Get medical attention for eyes.

WARNING

Hydraulic fluid ejected under pressure can cause injury to personnel. Hydraulic fluid sprayed into the air is a fire hazard.

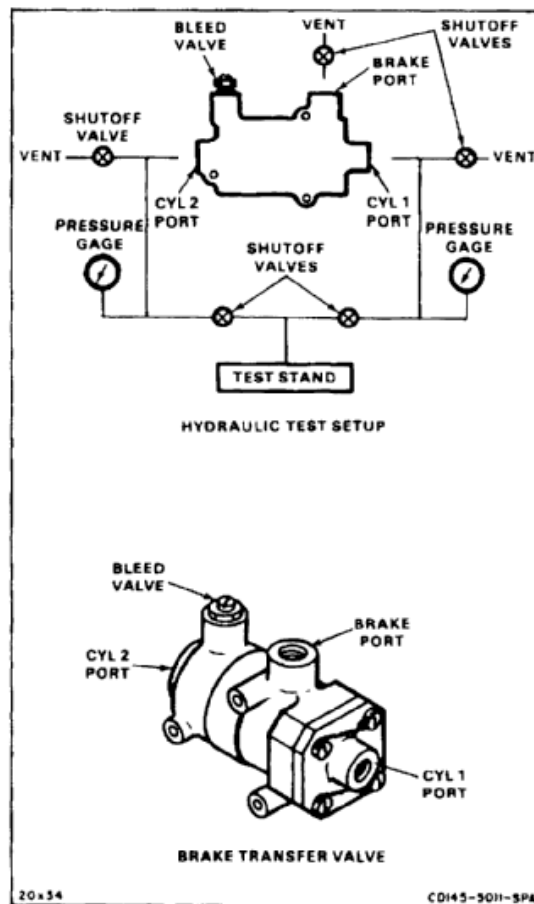

1. Connect hose (1) to CYL 1 port (2) of transfer valve (3).
2. Connect hose (4) to CYL 2 port (5) of transfer valve (3).
3. Connect hose (6) to BRAKE port (7) of transfer valve (3).

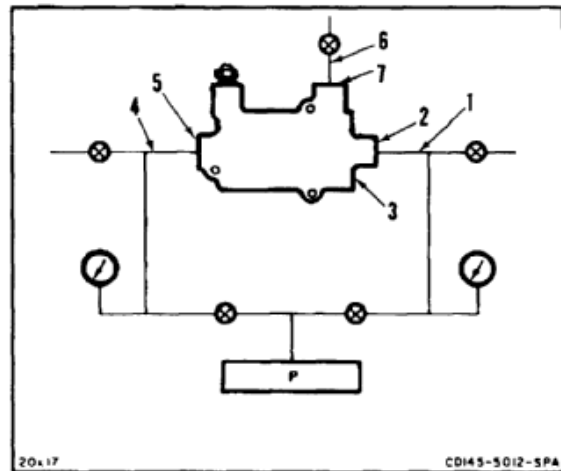

4. Close shutoff valves (8, 9 and 10).
5. Open shutoff valves (11 and 12).
6. Fill transfer valve (3) by applying **30 psi** pressure to CYL 1 port (2).
7. Position container (13) under hose (6).
8. Open shut off valve (8) until transfer valve (3) is free of air. Close shutoff valve. Use gloves (E186).
9. Raise pressure at CYL 1 port (2) to **2250 psi**. Maintain pressure for **3 minutes**.
10. Check transfer valve (3). There shall be no external leaks.
11. Check CYL 2 port (5). There shall be no leaks.
12. Reduce pressure at CYL 1 port (2) to **0 psi**.

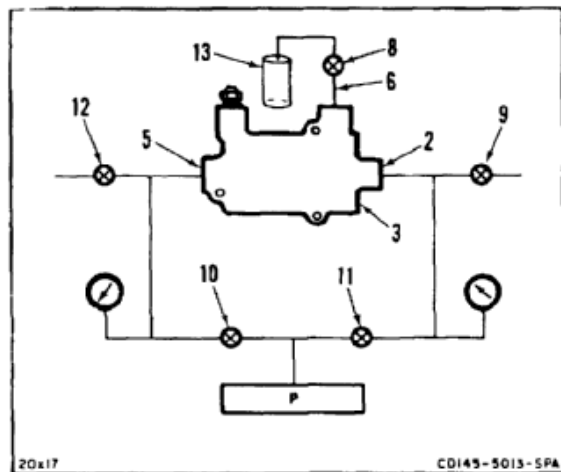

13. Close shutoff valves (11 and 12).
14. Open shutoff valves (9 and 10).
15. Fill transfer valve (3) by applying **30 psi** pressure to CYL 2 port (5).
16. Open BLEED valve (14) until transfer valve (3) is free of air. Close BLEED valve. Clean up spilled fluid with cloths (E120). Use gloves (E186).
17. Raise pressure at CYL 2 port (5) to **2250 psi**. Maintain pressure for **3 minutes**.
18. Check transfer valve (3). There shall be no external leaks.
19. Check CYL 1 port (2). There shall be no leaks.
20. Remove container (13).
21. Reduce pressure at CYL 2 port (5) to **0 psi**.

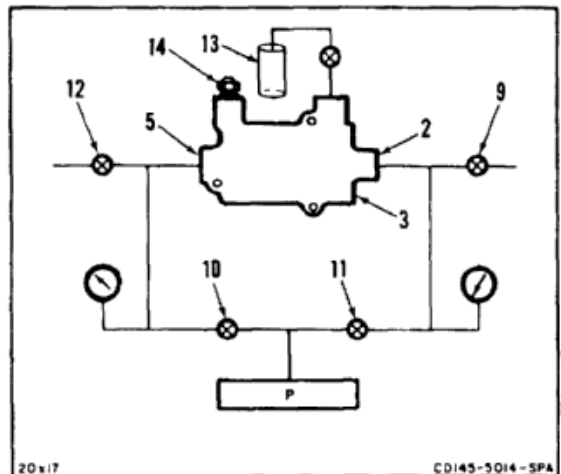

22. Position graduate cylinder (15) under hose (6).
23. Apply **100 psi** pressure to CYL 2 port (5).
24. Close shutoff valve (9).
25. Slowly open shutoff valve (11) until gage (16) reads **30 psi**.
26. Open shutoff valve (8) for **1 minute**, then close shutoff valve.
27. Check fluid level in graduate cylinder (15). Fluid level shall be more than **20 cc**.
28. Reduce pressure at CYL 2 port (5) to **0 psi**.
29. Remove graduate cylinder (15).

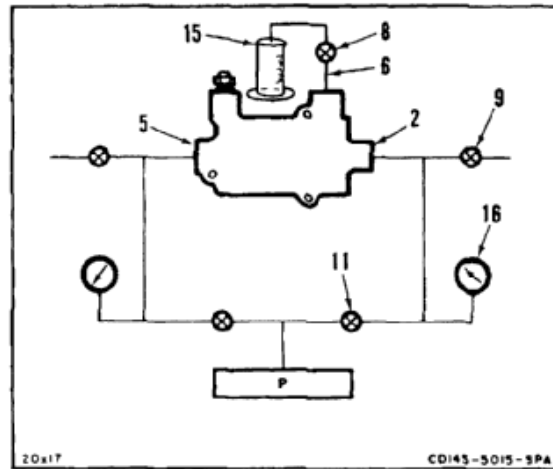

30. Open shutoff valves (8 and 9).
31. Close shutoff valve (11).
32. Apply **5 psi** pressure to CYL 2 port (5). Maintain pressure for **3 minutes**.
33. Check CYL 1 port (2) and brake port (7). There shall be no leaks.
34. Apply **500 psi** pressure to CYL 2 port (5). Maintain pressure for **3 minutes**.
35. Check CYL 1 port (2) and brake port (7). There shall be no leaks.
36. Apply **1200 psi** pressure to CYL 2 port (5). Maintain pressure for **3 minutes**.
37. Check CYL 1 port (2) and brake port (7). There shall be no leaks.
38. Reduce pressure at CYL 2 port (5) to **0 psi**.

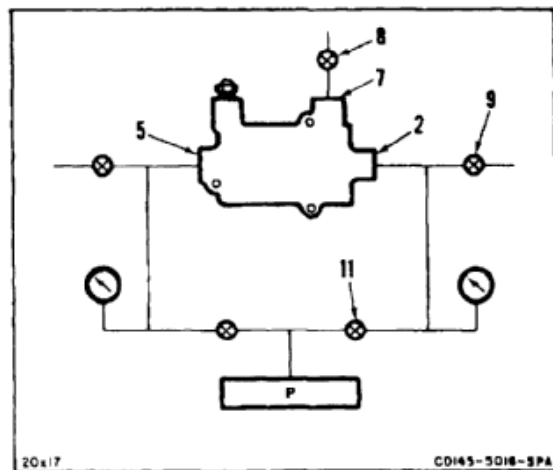

39. Fill brake port (7) with hydraulic fluid (E199).
40. Close shutoff valve (8).
41. Disconnect hose (1) from CYL 1 port (2).
42. Apply **10 psi** pressure to CYL 2 port (5). Maintain pressure for **3 minutes**.
43. Check CYL 1 port (2). Leaks shall not exceed **1 drop per minute**.
44. Apply **500 psi** pressure to CYL 2 port (5). Maintain pressure for **3 minutes**.
45. Check CYL 1 port (2). Leaks shall not exceed **1 drop per minute**.
46. Apply **1200 psi** pressure to CYL 2 port (5). Maintain pressure for **3 minutes**.
47. Check CYL 1 port (2). Leaks shall not exceed **1 drop per minute**.
48. Reduce pressure at CYL 2 port (5) to **0 psi**.

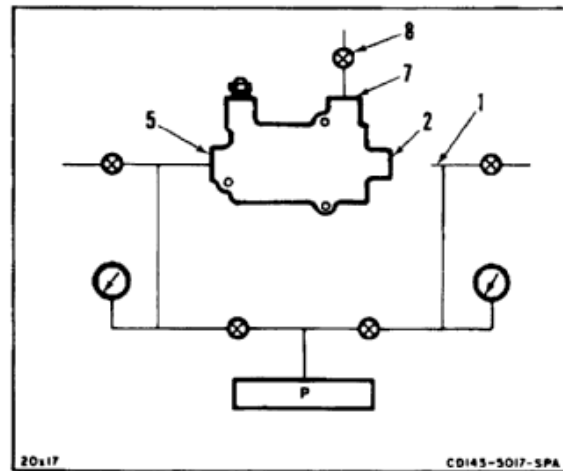

49. Insert nylon rod (17) into CYL 1 port (2) until it touches end of poppet (18).
50. Open shutoff valve (8).
51. Slowly apply pressure to CYL 2 port (5) until nylon rod (17) starts to move.
52. Check pressure needed to start nylon rod (17) moving. Pressure needed to start nylon rod moving shall not exceed **12 psi**.
53. Reduce pressure at CYL 2 port (5) to **0 psi**.

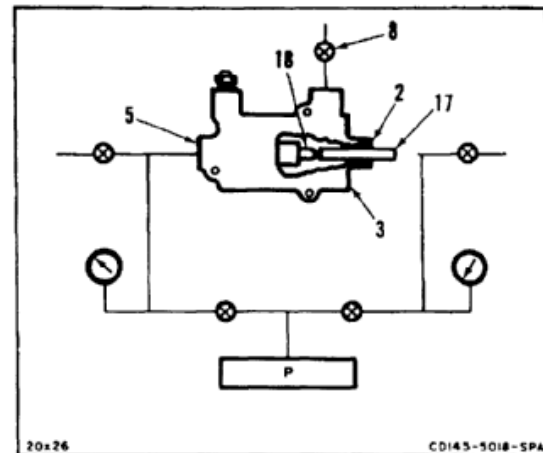

54. Disconnect hoses (4 and 6) from transfer valve (3).
55. Wipe up spills with cloths (E120). Use gloves (E186).
56. Lockwire BLEED valve (14). Use lockwire (E231).

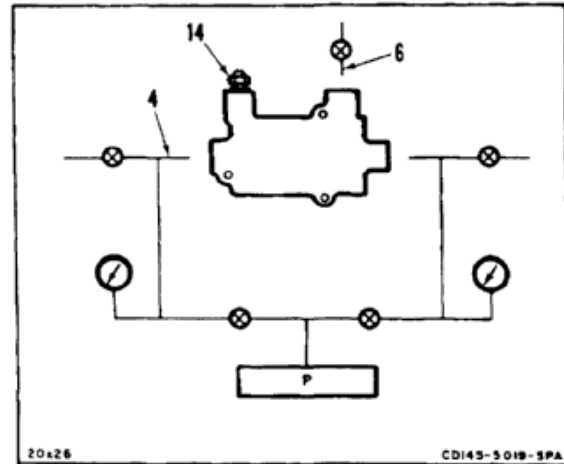
INSPECT**FOLLOW-ON MAINTENANCE:**

None

END OF TASK

7-884

INITIAL SETUP

Applicable Configurations:

All

Tools:

Aircraft Mechanic's Tool Kit, NSN 51 80-00-323-4692

Materials:

None

Parts:

Performed Packings

Personnel Required:

Medium Helicopter Repairer (2)
Inspector

References:

TM 55-1520-240-23P

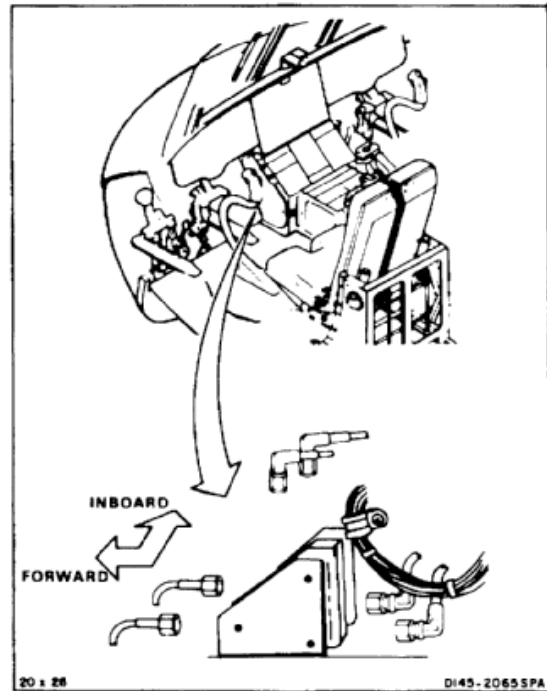

NOTE

To install inboard brake transfer valve, perform steps 1 thru 5. To install outboard brake transfer valve, perform steps 6 thru 10.

INBOARD VALVE

1. Install three packings (1) and nipples (2) in valve (3).
2. Position valve (3) between mounts (4).
3. Install six washers (5), three screws (6), and nuts (7). Have helper hold screw heads when installing nuts.
4. Connect three hydraulic tubes (8). Remove tags.

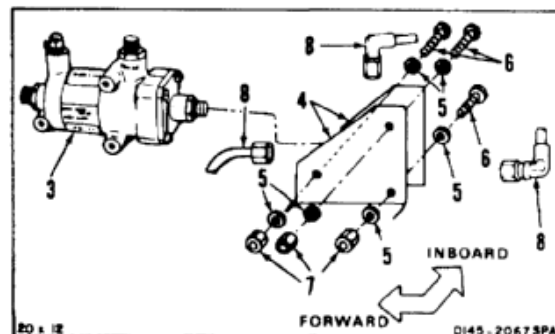
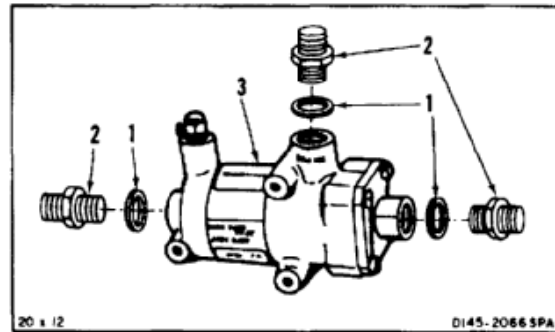

OUTBOARD VALVE

5. Install three packings (9) and nipples (10).

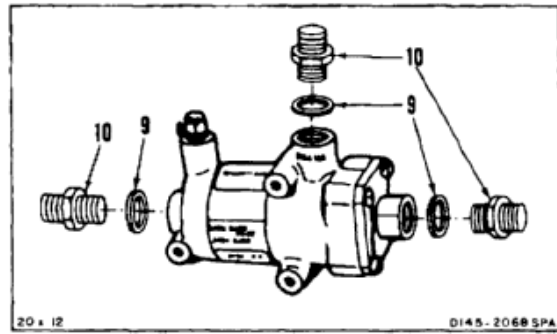

6. Position valve (11) between mounts (12).
 7. Install six washers (13), three screws (14), and nuts (15).
 8. Connect three hydraulic tubes (16). Remove tags.

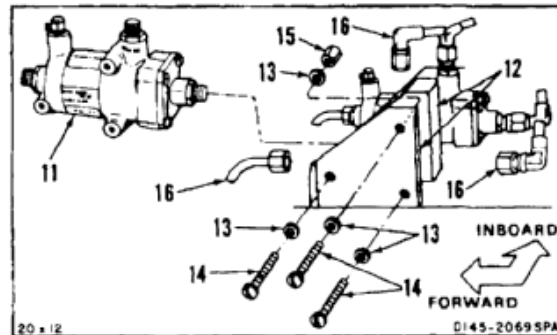
**INSPECT****FOLLOW-ON MAINTENANCE:**

Bleed brake hydraulic system (Task 7-330).
 Perform operational check of brake hydraulic system
 (TM 55-1520-240-T).

END OF TASK

7-886

7-237 REMOVE PARKING BRAKE VALVE

7-237

INITIAL SETUP**Applicable Configurations:**

All

Tools:

Aircraft Mechanic's Tool Kit, NSN 5180-00-323-4692

Materials:Cloths (E135)
Gloves (E186)**Personnel Required:**

Medium Helicopter Repairer (2)

Equipment Condition:Battery Disconnected (Task 1-39)
Electrical Power Off
Hydraulic Power Off
Utility Hydraulic System Depressurized (Task 7-135.1)
Pilot's Seat Fully Aft (Task 2-115)**General Safety Instructions:****WARNING**

Hydraulic fluid (E199) is toxic. It can irritate skin and cause burns. Avoid inhaling. Use only with adequate ventilation. Avoid contact with skin, eyes, or clothing. In case of contact, immediately flush skin or eyes with water for at least **15 minutes**. Get medical attention for eyes.

WARNING

Hydraulic fluid ejected under pressure can cause injury to personnel. Hydraulic fluid sprayed into the air is a fire hazard.

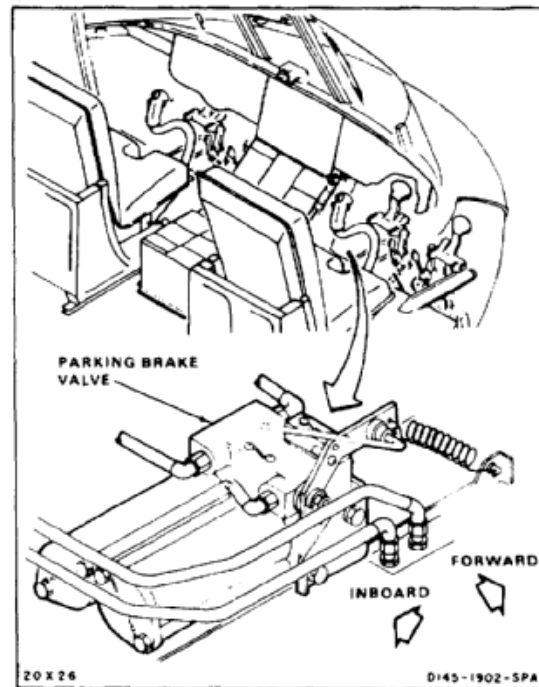

1. Operate cockpit foot brake pedals ten times to relieve system pressure.
- 1.1. Disconnect four hydraulic tubes (1) from parking brake valve (2). Use cloths (E135) for spilled fluid. Use gloves (E186).
2. Remove lockwire, two screws (3) and washers (4) from switch (5).
3. Remove switch (5) and spacer (6) from valve (2).

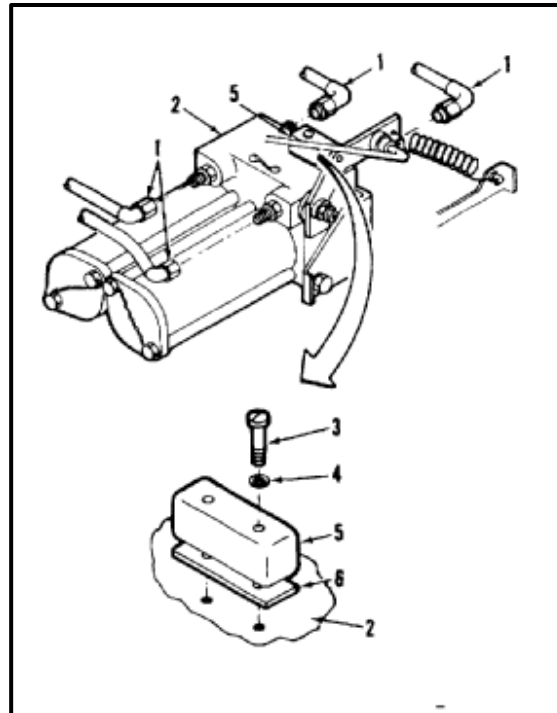

4. Disconnect spring (7) from mount (8) and lever (9).
5. Remove cotter pin (10), washer (11), two bushings (12), washer (13), and bushing (14) from rod (15). Disconnect rod from lever (9).

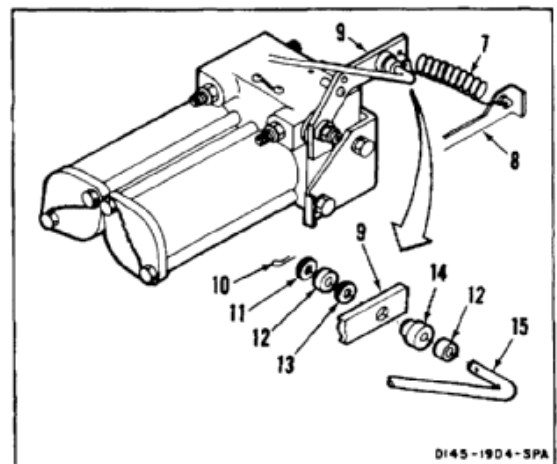

7-237 REMOVE PARKING BRAKE VALVE (Continued)

7-237

6. Remove two nuts (16), four washers (17), and two bolts (18). Remove valve (2).
7. Remove two nipples (19) and packings (20) from valve (2).

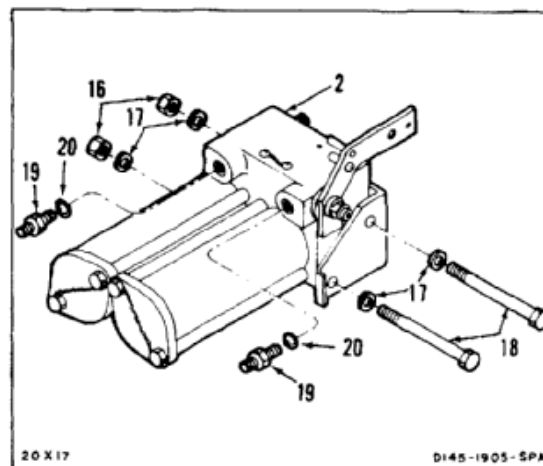
**FOLLOW-ON MAINTENANCE:**

None

END OF TASK

INITIAL SETUP

Applicable Configurations:

All

Tools:

Aircraft Mechanic's Tool Kit, NSN 5180-00-323-4692

Materials:

Lockwire (E231)

Parts:

Preformed Packings
 Nonmetallic Washers
 Cotter Pin

Personnel Required:

Medium Helicopter Repairer (2)
 Inspector

References:

TM 55-1520-240-23P

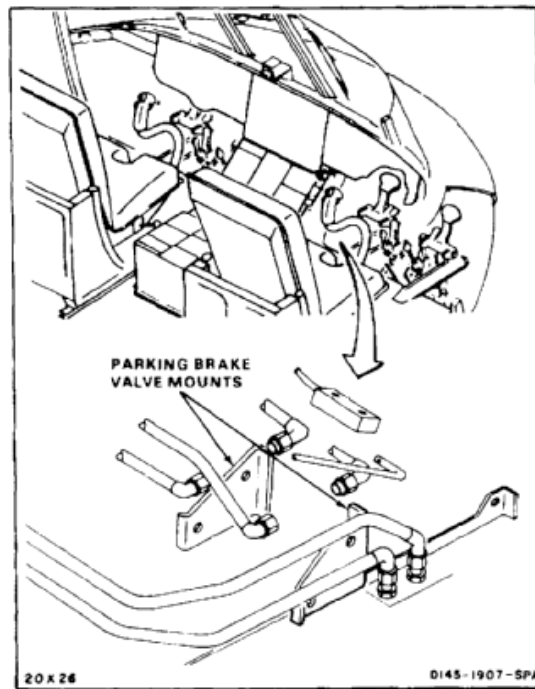

1. Install two packings (1) and nipples (2).
2. Position valve (3) between mounts (4) as shown.
3. Install four washers (5), two bolts (6), and nuts (7).

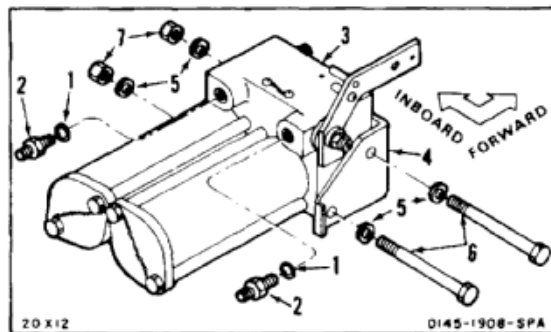

4. Connect four hydraulic tubes (8).
5. Connect spring (9) to lever (10) and mount (11).

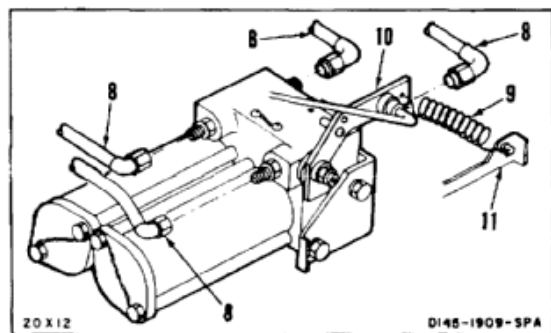

6. Position spacer (12) and switch (13) on valve (3) as shown.
7. Install two washers (14) and screws (15).
8. Install lockwire on screws (15). Use lockwire (E231).

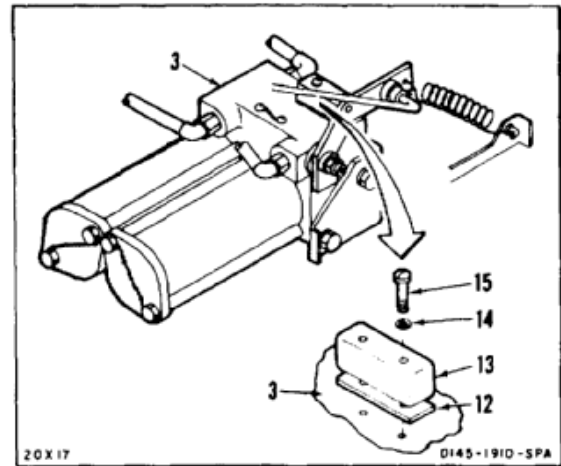

9. Install bushing (16), bushing (17) and rod (18) in lever (10).
10. Install washer (19), bushing (17) and washer (20) on rod (18).
11. Install cotter pin (21) in rod (18).

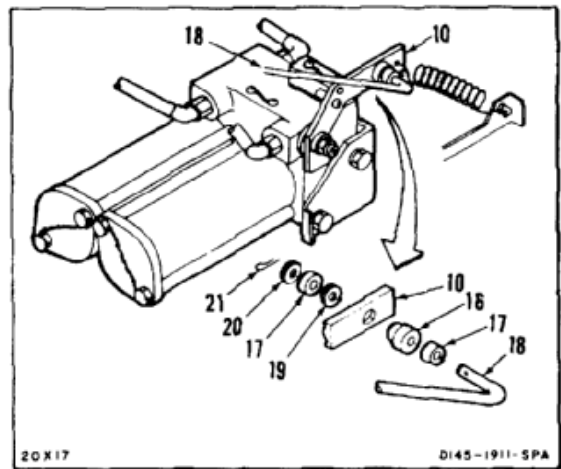
**INSPECT****FOLLOW-ON MAINTENANCE:**

- Bleed brake hydraulic system (Task 7-330).
- Perform operational check (TM 55-1520-240-T).

END OF TASK

INITIAL SETUP

Applicable Configurations:

All

Tools:

Aircraft Mechanic's Tool Kit, NSN 5180-00-323-4692
Torque Wrench, 30 to 150 Inch-Pounds

Materials:

None

Parts:

Cotter Pin

Personnel Required:

Medium Helicopter Repairer (2)
Inspector

Equipment Condition:

Battery Disconnected (Task 1-39)
Electrical Power Off
Hydraulic Power Off

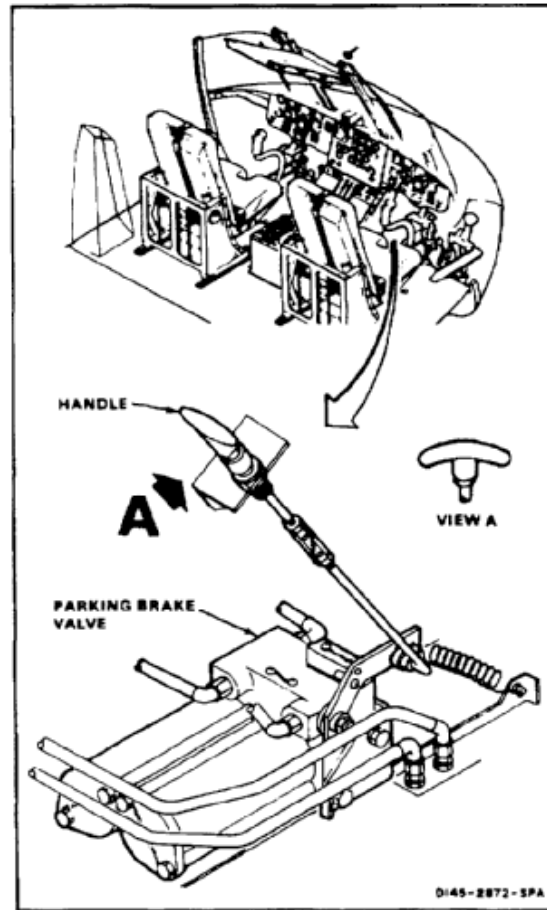

1. Hold handle (1) in full on position.
2. Press pilot's pedals (2).
3. Return handle (1) slowly to full off position.
Release pedals (2).

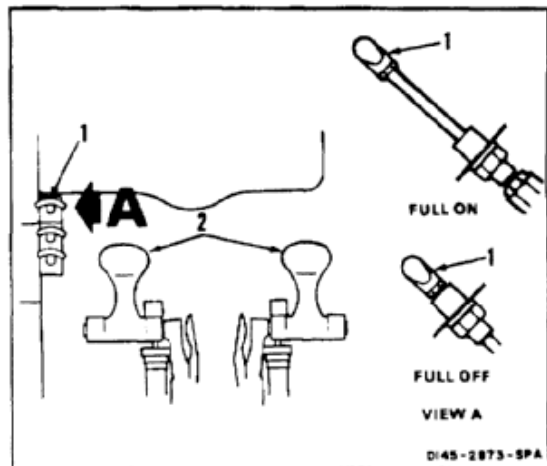

4. Remove cotter pin (3) and three washers (4) from rod (5).
5. Disconnect rod (5) from lever (6). Leave spacer (7) and bushing (8) on rod.

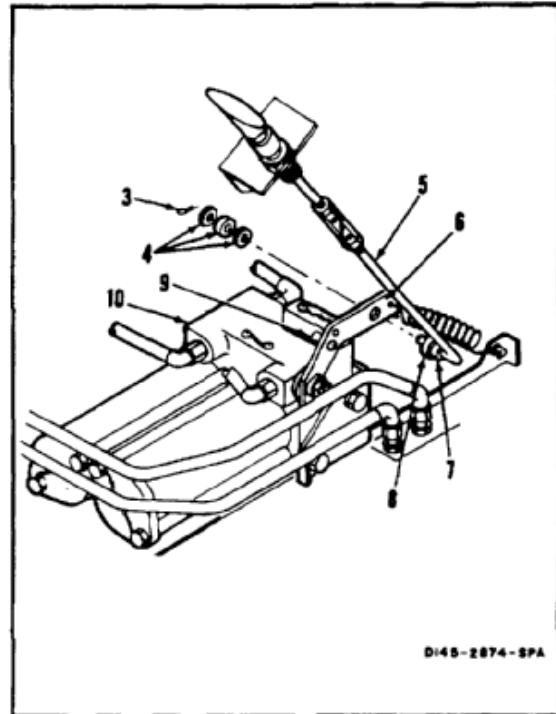

6. Loosen nuts (11 and 12).
7. Hold handle (1). Loosen nut (13). Turn handle clockwise until it bottoms on rod (14). Tighten nut.
8. Have helper press and hold handle (1) against fitting (15).
9. Turn turnbuckle (16) and nut (11) until distance between nut (11) and fitting (15) is **2.32 inches**. Tighten turnbuckle (16) against nut (11).
10. Check that thread of rod (14) can be seen in inspection hole (17).

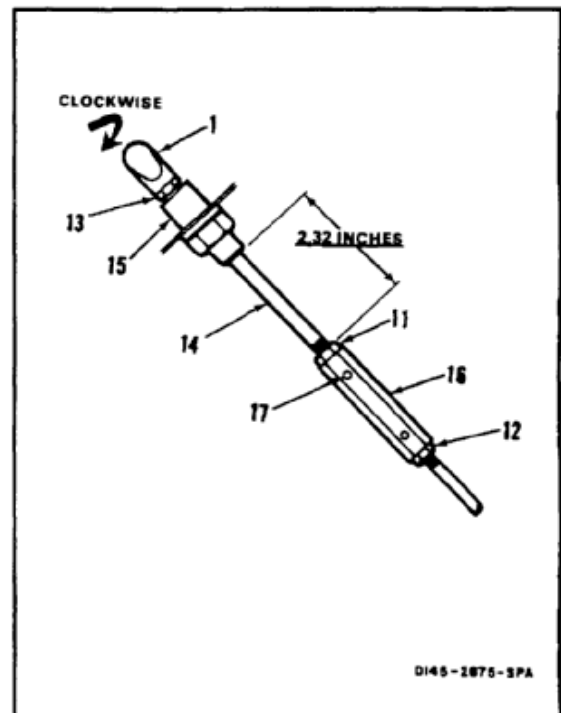

11. Keep handle (1) pressed against fitting (15).
12. Slide bushing (8) from rod (5). Install bushing in hole (18) of lever (6).
13. Hold turnbuckle (16). Turn rod (5) until rod end aligns with bushing (8) in lever (6). Turn rod clockwise to lengthen. Turn rod counterclockwise to shorten.
14. Install rod (5) in bushing (8). Install three washers (4) and cotter pin (3).
15. Tighten nut (12) against turnbuckle (16).
16. Check that thread of rod (5) can be seen in inspection hole (19).
17. Deleted.

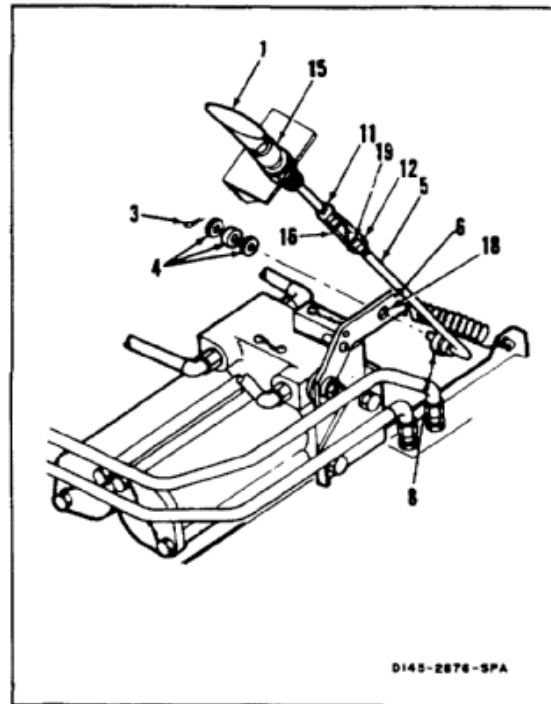

18. Hold handle (1). Loosen nut (13). Turn handle and nut counterclockwise until distance between nut and fitting (15) is **0.03 to 0.04 inch**.
19. Position handle as shown. Torque nut to **80 inch-pounds**.

INSPECT

FOLLOW-ON MAINTENANCE:

Perform operational check (TM 55-1520-240-T).

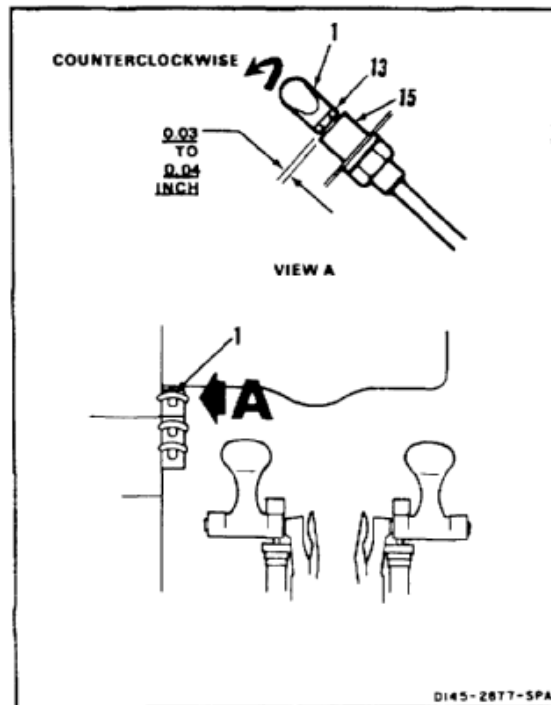

END OF TASK

INITIAL SETUP

Applicable Configurations:

All

Tools:

Aircraft Mechanic's Tool Kit, NSN 5180-00-323-4692
Container, 2 Quart

Materials:

Cloths (E120)
Gloves (E186)

Personnel Required:

Medium Helicopter Repairer

Equipment Condition:

Battery Disconnected (Task 1-39)
Electrical Power Off
Hydraulic Power Off
Utility Hydraulic System Depressurized (Task 7-135.1)
Forward Fairing Left Work Platform Open (Task 2-2)
Brake Accumulator Depressurized (Task 1-67)

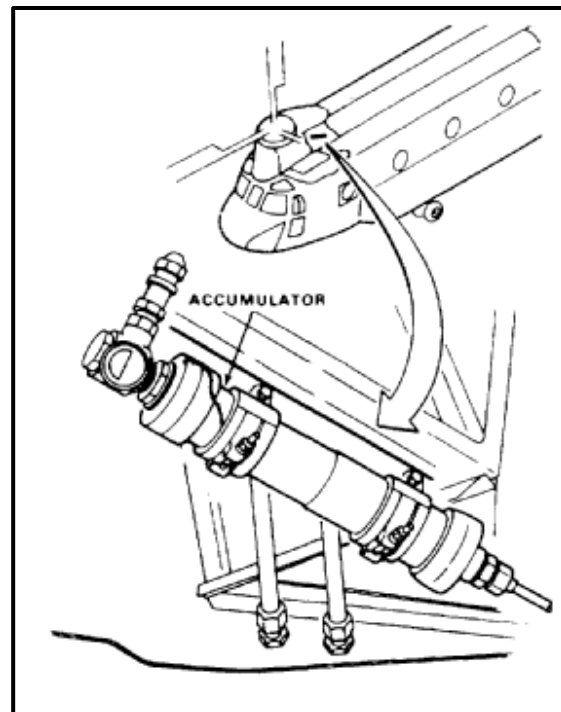
**General Safety Instructions:****WARNING**

Hydraulic fluid (E199) is toxic. It can irritate skin and cause burns. Avoid inhaling. Use only with adequate ventilation. Avoid contact with skin, eyes, or clothing. In case of contact, immediately flush skin or eyes with water for at least **15 minutes**. Get medical attention for eyes.

WARNING

Hydraulic fluid ejected under pressure can cause injury to personnel. Hydraulic fluid sprayed into the air is a fire hazard.

1. Carefully remove cap (1) from air-charge valve (2), allowing any trapped air to escape.
2. Hold body of valve (2) with wrench. Turn outer nut (2.1) counterclockwise slowly to open valve.
3. Disconnect tube (3) from reducer (4). Use cloths (E120) for spilled fluid. Use gloves (E186).

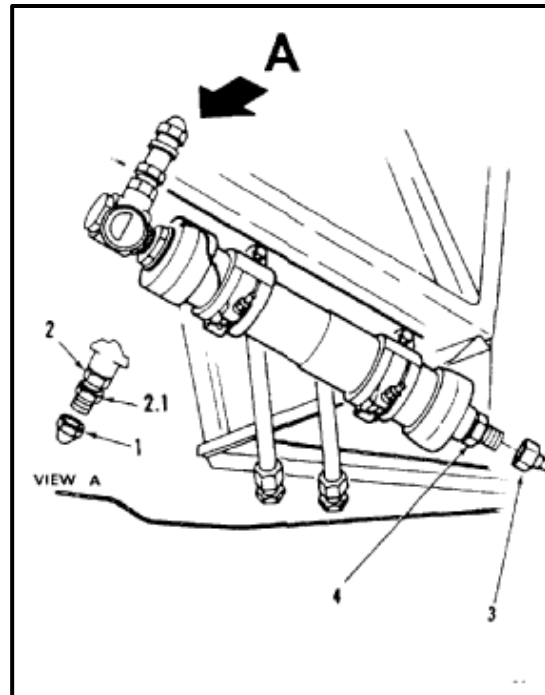

4. Remove two nuts (5) from two clamps (6).
5. Open two clamps (6).
6. Remove accumulator (7).

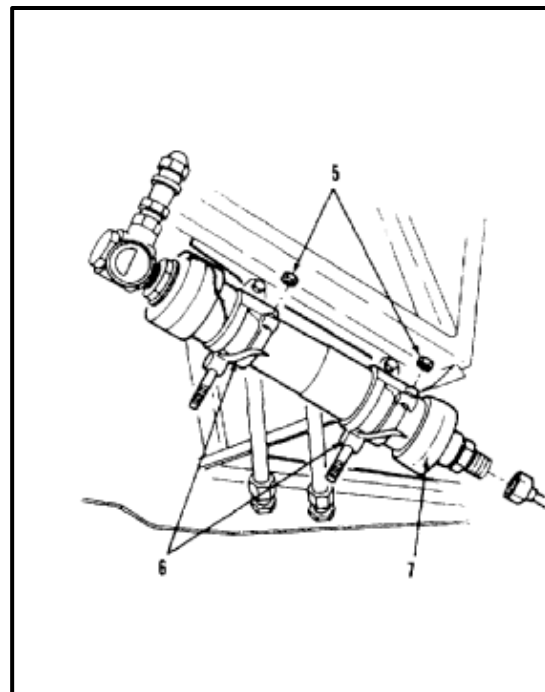

7-240 REMOVE EMERGENCY BRAKE ACCUMULATOR (Continued)**7-240**

7. Remove union (8), valve and gage assembly (9), and packing (10) from accumulator (7).
8. Remove reducer (11) and packing (12) from accumulator (7).

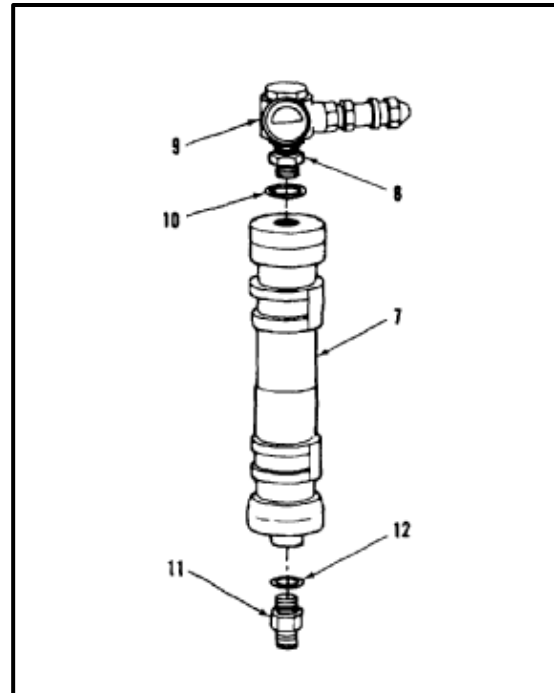
***FOLLOW-ON MAINTENANCE:***

None

END OF TASK

INITIAL SETUP

Applicable Configurations:

All

Tools:

- Hydraulic Repairer's Tool Kit, NSN 5180-00-323-4891
- Strap Wrench, 1-5/16 to 5-9/16 Inch
- Heat Gun
- Arbor Press
- Aluminum Dowel, 3/8 Inch X 16 Inches
- Technical Inspection Tool Kit, NSN 5180-00-323-5114
- Outside Micrometer Caliper, 1 to 2 Inch
- Telescoping Gage Set

Personnel Required:

- Aircraft Pneudraulics Repairer
- Inspector

References:

Task 7-1.1

Equipment Condition:

Off Helicopter Task

NOTE

General inspection criteria (Task 7-1.1) for obvious damage applies unless otherwise stated.

Inspection steps cover parts that are subject to wear.

1. Remove lockwire from mounting rings (1). Remove four mounting rings from shell (2). Pull outward.

2. Remove lockwire from end caps (3 and 4).
3. Hold shell (2). Use strap wrench.

NOTE

End caps are marked HYD and GAS.

4. Remove two end caps (3 and 4). Turn counterclockwise. Use wrench on flats of ports (5 and 6).

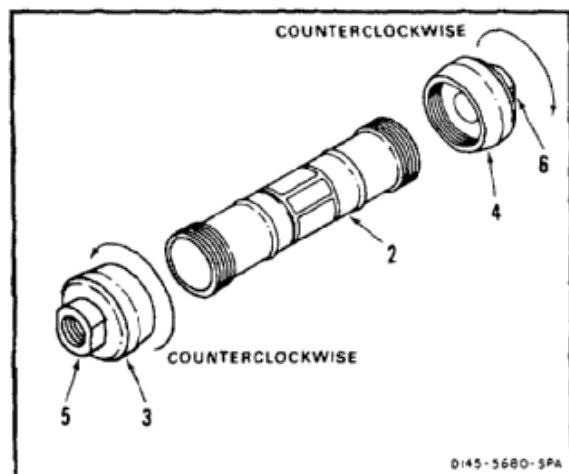
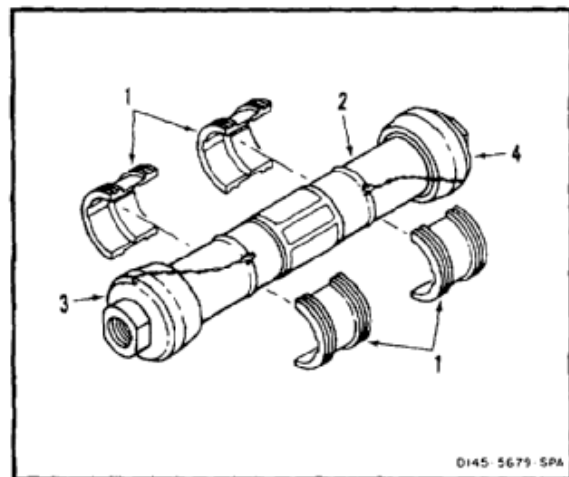
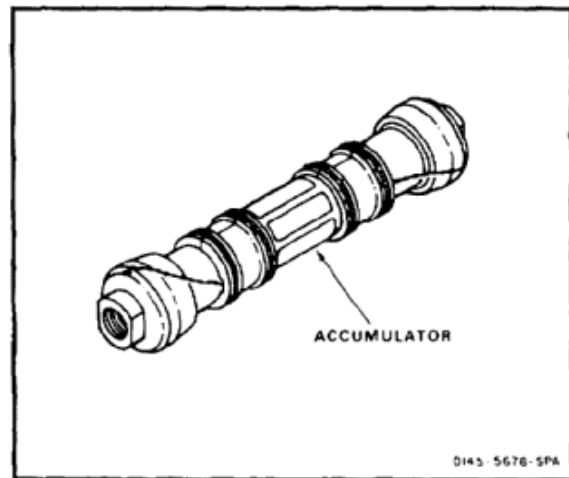

7-241 DISASSEMBLE AND INSPECT ACCUMULATOR (1356-643887M1)(AVIM) (Continued)

5. Remove lockwire from two screws (7) in end cap (3). Remove screws.
6. Remove retainer (8) and packing (9) from cap (3).

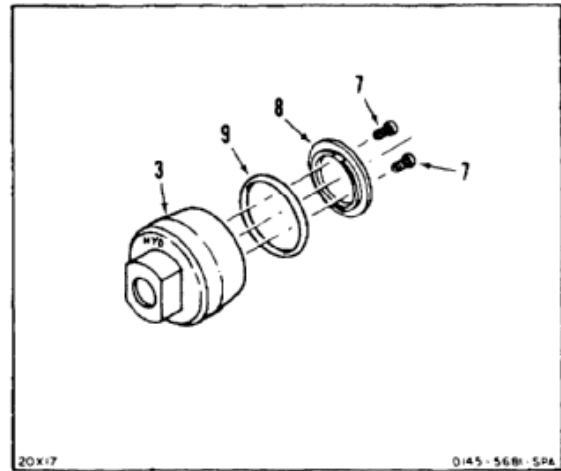

7. Remove lockwire from two screws (10) in end cap (4). Remove screws.
8. Remove retainer (11) and packing (12) from cap (4).

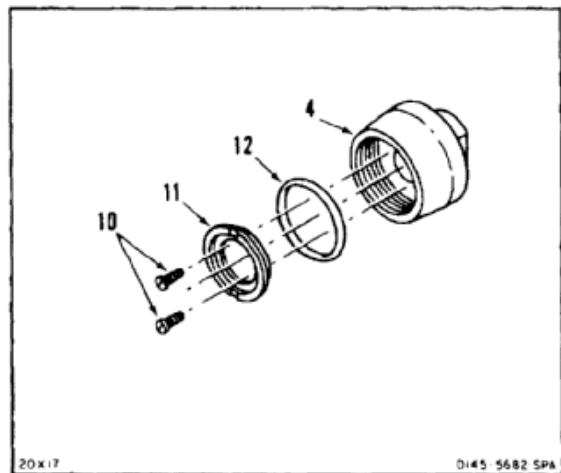

9. Push piston (13) from shell (2). Use rod (14) and arbor press. Remove piston.

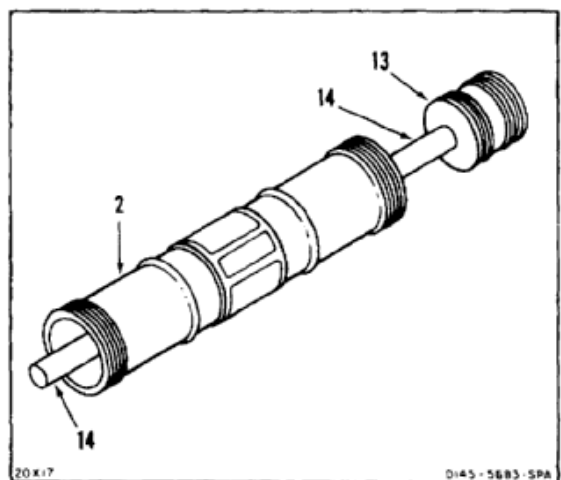

10. Remove four rings (15) and packing (16) from piston (13).
11. Measure outside diameter of piston (13) at six lands (17). Diameter shall not be less than **1.854+.000/-.002 inches**.

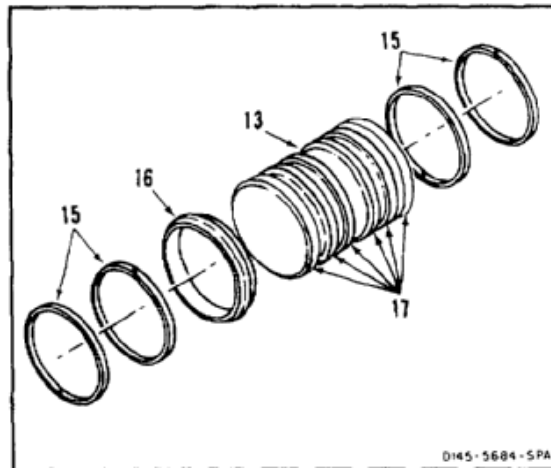

12. If nameplate (18) is damaged or shell (2) is to be replaced, remove nameplate and strap (18). Use heat gun.
13. Measure inside diameter of shell (2). Diameter shall not be more than **1.859+.002/-.000 inches**.

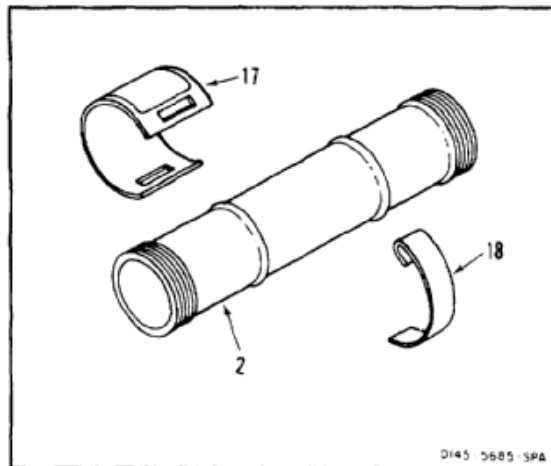
**FOLLOW-ON MAINTENANCE:**

None

END OF TASK

7-900

7-241.1 DISASSEMBLE AND INSPECT ACCUMULATOR (08-8421-020) (AVIM)

7-241.1

INITIAL SETUP**Applicable Configurations:**

All

Tools:

Hydraulic Repairer's Tool Kit, NSN 5180-00-323-4891
 Open End Wrench, 1-1/8 Inch
 Strap Wrench, 1-5/16 X 5-9/16 Inch
 Arbor Press
 Teflon Dowel, 3/8 Inch X 16 Inches
 Technical Inspection Tool Kit, NSN 5180-00-323-5114

Materials:

None

Personnel Required:

Aircraft Pneudraulics Repairer
 Inspector

References:

Task 7-1.1

Equipment Condition:

Off Helicopter Task

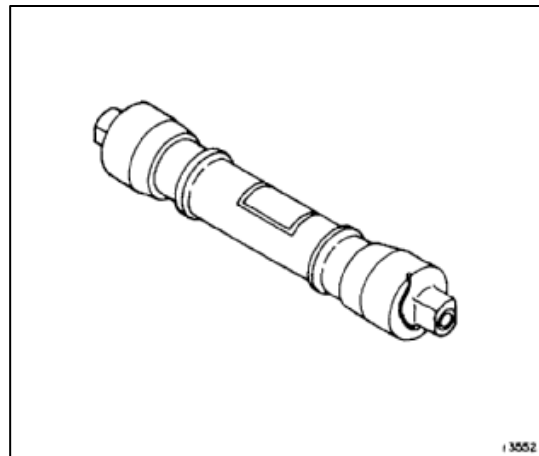
**NOTE**

General inspection criteria (Task 7-1.1) for obvious damage applies unless otherwise stated.

Inspection steps cover parts that are subject to wear.

1. Remove lockwire from end caps (1 and 2) and screw caps (3).
2. Hold screw cap (3). Use strap wrench.

NOTE

End caps are marked FLUID and AIR.

3. Remove end caps (1 and 2). Turn counterclockwise. Use **1-1/8 inch** open end wrench on flats of ports (5 and 6).
4. Remove packing (7) and backup ring (8) from end caps (1 and 2).

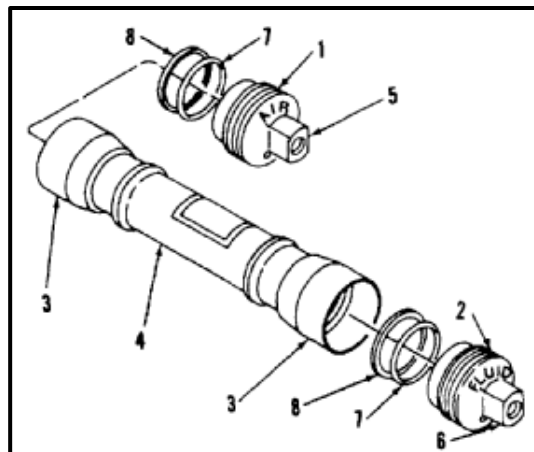

5. Push piston (9) from cylinder (4). Use rod (10) and arbor press.

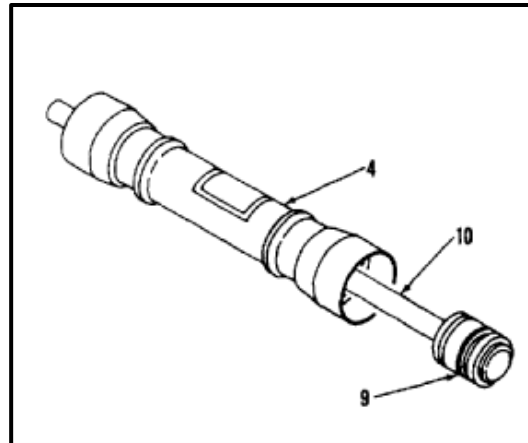

6. Remove two rings (11), packing (12), and bearing (13) from piston (9).
7. Measure outside diameter of piston (9) at lands (14 and 15). Diameter of land (14) shall not be less than **1.818 inches**; diameter of lands (15) shall not be less than **1.837 inches**.

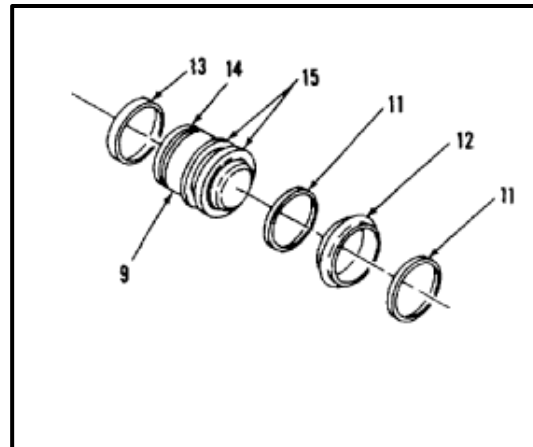

8. Remove screw cap (3) and shoulder ring (16) from each end of cylinder (4) by sliding screw cap (3) down cylinder until shoulder ring (16) releases.

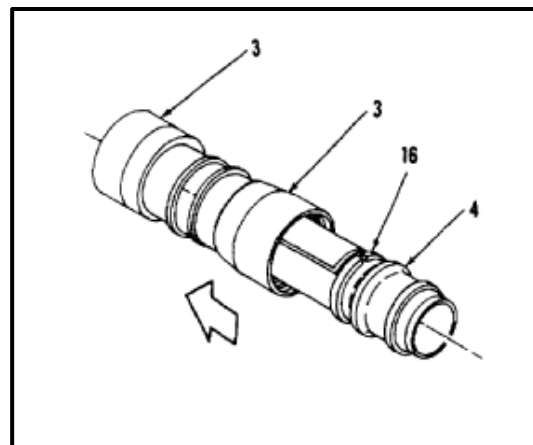

7-241.1 DISASSEMBLE AND INSPECT ACCUMULATOR (08-8421-020) (AVIM) (Continued)

7-241.1

9. Measure inside diameter of cylinder (4).
Diameter shall not be more than **1.846 inches**.

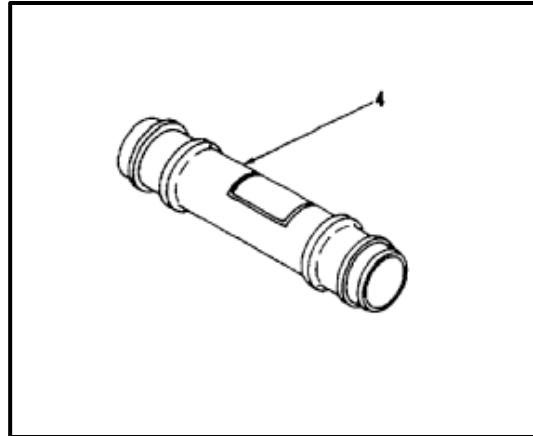
***FOLLOW-ON MAINTENANCE:***

None

END OF TASK

INITIAL SETUP

Applicable Configurations:

All

Tools:

Hydraulic Repairer's Tool Kit, NSN 5180-00-323-4891
 Strap Wrench, 1-5/16 to 5-9/16 Inches
 Crow Foot Wrench, 1 Inch
 Torque Wrench, 700 to 1600 Inch-Pounds

Materials:

Cloth (E120)
 Lockwire (E227)
 Adhesive (E43)
 Methyl-Ethyl-Ketone (E244)
 Gloves (E186)

Parts:

Packing
 Rings

Personnel Required:

Aircraft Pneudraulics Repairer
 Inspector

References:

TM 55-1520-240-23P

1. Install packing (1) on piston (2).
2. Install two rings (3), one on each side of packing (1). Make sure chamfer on rings is toward packing. Position slots in rings **180°** apart.
3. Install two rings (4), one on each end of piston (2). Position slots in rings **180°** apart.

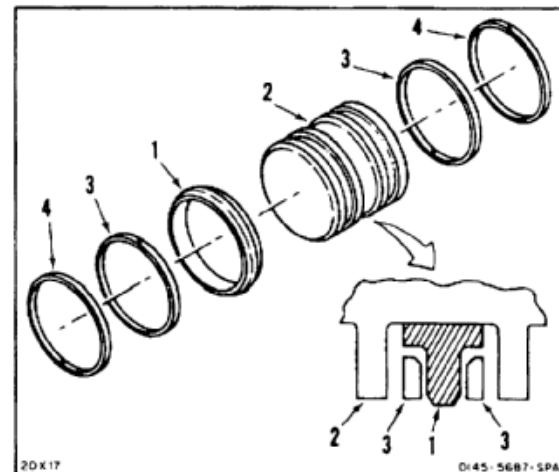
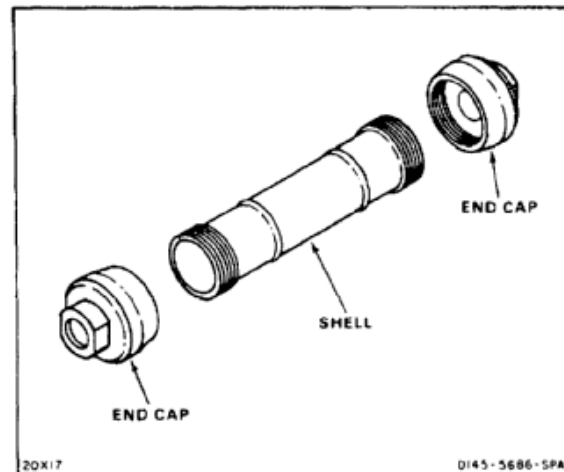
INSPECT

4. Install piston (2) in shell (5).

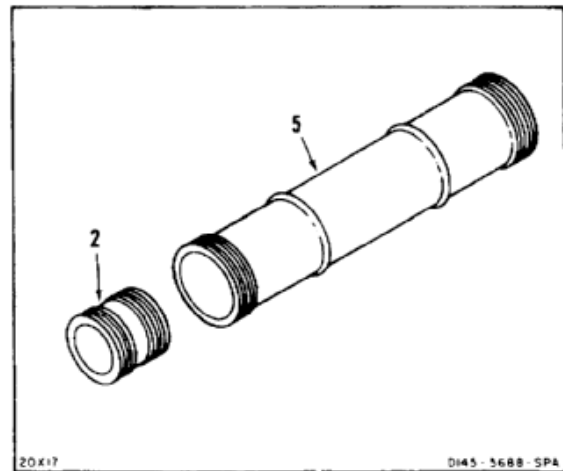

5. Install packing (7) on flange (8) of retainer (9).

NOTE

End caps are marked HYD and GAS.

6. Position retainer (9) in center of HYD cap (10), packing (7) toward cap. Install two screws (11). Torque screws to **12 inch-pounds**.
7. Lockwire two screws (11). Position lockwire around port (12). Use lockwire (E227).

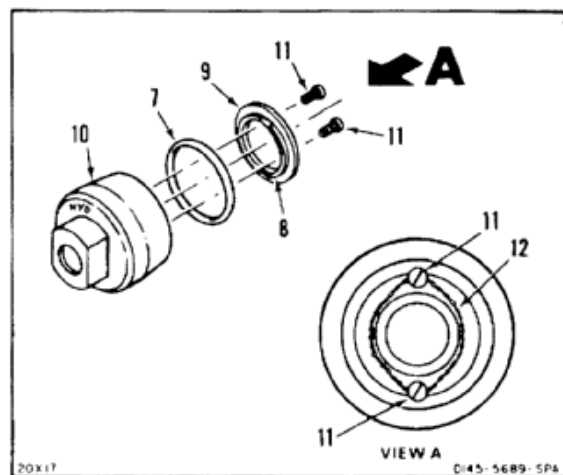

8. Install packing (13) on flange (14) of retainer (15).
9. Position retainer (15) in center of GAS cap (16), packing (13) toward cap. Install two screws (17). Torque screws to **12 inch-pounds**.
10. Lockwire two screws (17). Position lockwire around port (18). Use lockwire (E227).

INSPECT

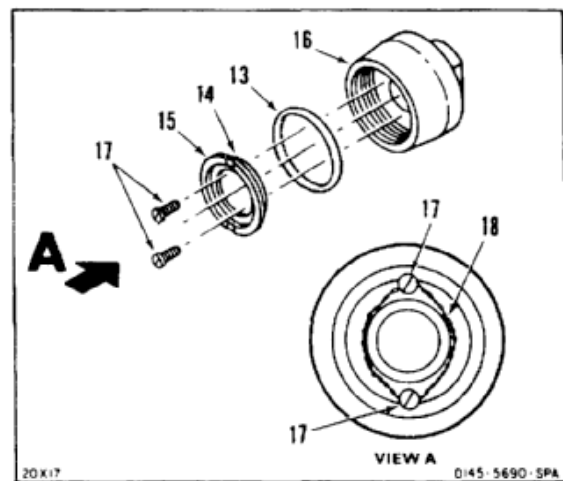

11. Install GAS cap (16) on shell (5). Make sure cap is toward hollow end of piston (2).
12. Install HYD cap (10) on shell (5).
13. Torque caps (10 and 16) to **1500 inch-pounds**. Use crow foot wrench.

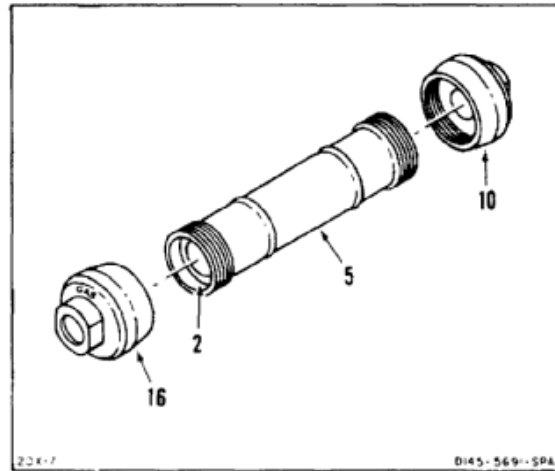

14. Lockwire end caps (10 and 16) to shell (5) with lockwire (E227) as follows:
 - a. Position loop (19) of lockwire in slots (20) of shell.
 - b. Install four mounting rings (21) on shell, with lockwire positioned in slots (22) of mounts.
 - c. Lockwire rings on shell.

INSPECT

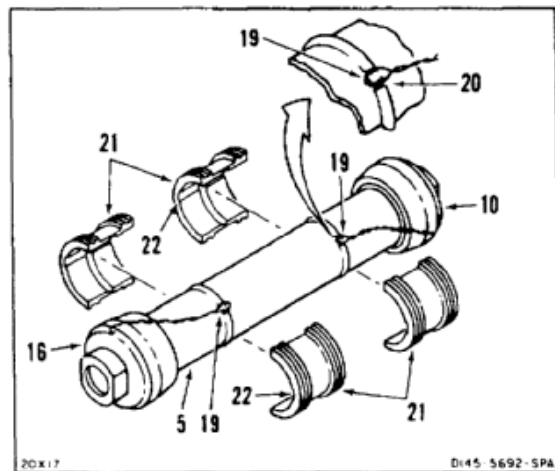

15. If shell (5) is a replacement or nameplate (23) was removed, install nameplate as follows:

WARNING

Methyl-ethyl-ketone (E244) is flammable and toxic. It can irritate skin and cause burns. Use only in well-ventilated area, away from heat and open flame. In case of contact, immediately flush skin or eyes with water for at least **15 minutes**. Get medical attention for eyes.

- a. Clean shell (5), nameplate (23), and strap (24) with methyl-ethyl-ketone (E244). Use cloth (E120) and gloves (E186).

WARNING

Adhesive (E43) can irritate skin and cause burns. Avoid contact with skin, eyes, and clothing. In case of contact, immediately flush skin or eyes with water for at least **15 minutes**. Get medical attention for eyes.

- b. Apply adhesive (E43) to all contact surfaces between shell (5), nameplate (23), and strap (24).
- c. Wrap nameplate (23) and strap (24) around shell (5). Interlock by running strap through nameplate and bending.

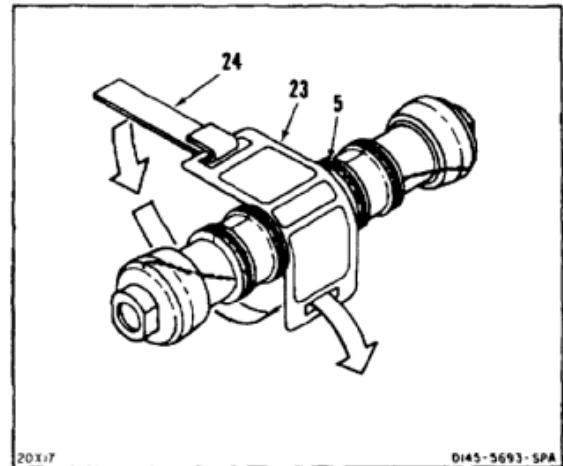
**FOLLOW-ON MAINTENANCE:**

Test accumulator (Task 7-243).

END OF TASK

INITIAL SETUP

Applicable Configurations:

All

Tools:

Hydraulic Repairer's Tool Kit, NSN 5180-00-323-4891
 Strap Wrench, 1-5/16 X 5-9/16 Inch
 Open End Wrench, 1-1/8 Inch

Materials:

Lockwire (E231)

Parts:

Packing
 Rings

Personnel Required:

Aircraft Pneudraulics Repairer

References:

TM 55-1520-240-23P

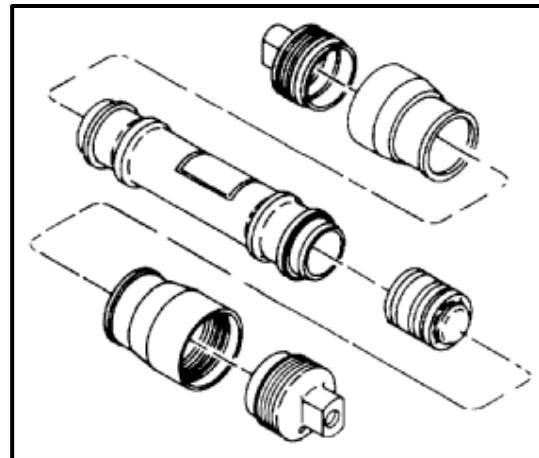

1. Install packing (1) on piston (2).
2. Install one ring (3) on each side of packing (1). Make sure chamfer on rings is toward packing. Position slots in rings **180°** apart.
3. Install bearing (4) on piston (2).
4. Install piston (2) in cylinder (5). Use an arbor press.

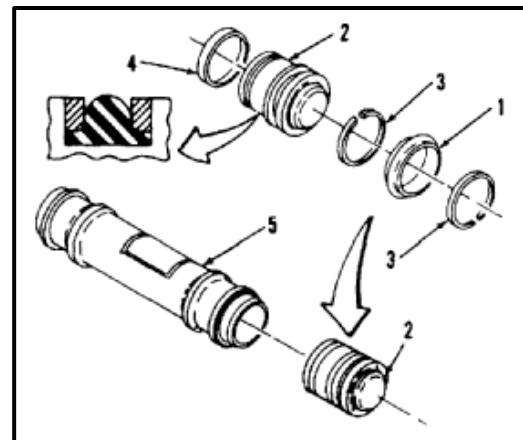

5. Install a shoulder ring (6) on end of cylinder (5) with piston (2). Install screw cap (7) over opposite end of cylinder (5) and pull in place against shoulder ring (6).
6. Slide second screw cap (7) over cylinder (5). Install second shoulder ring (6) and pull screw cap (7) into place.

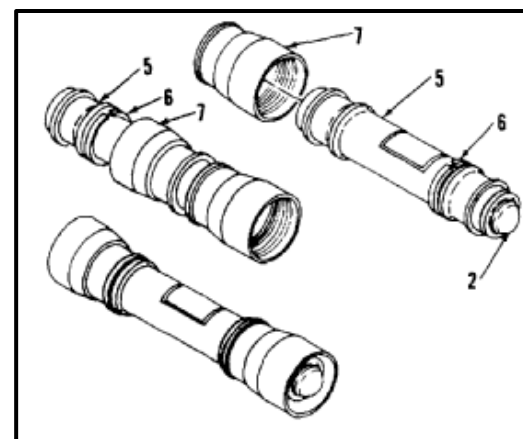

7-242.1 ASSEMBLE ACCUMULATOR (08-8421-020) (AVIM) (Continued)

7-242.1

7. Install backup ring (8) and packing (9) in end caps (10 and 11).

NOTE

End caps are marked FLUID and AIR.

8. Install end cap (10) marked FLUID in end of cylinder (5) toward closed end of piston (2). Install end cap (11) marked AIR in opposite end of cylinder (toward open end of piston).
9. Hold screw caps with strap wrench and tighten end caps. Use **1-1/8 inch** open end wrench.

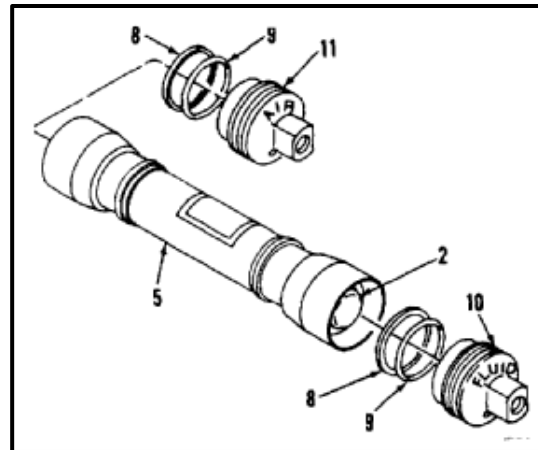

10. Lockwire end caps (10 and 11) to screw caps (7). Use lockwire (E231).

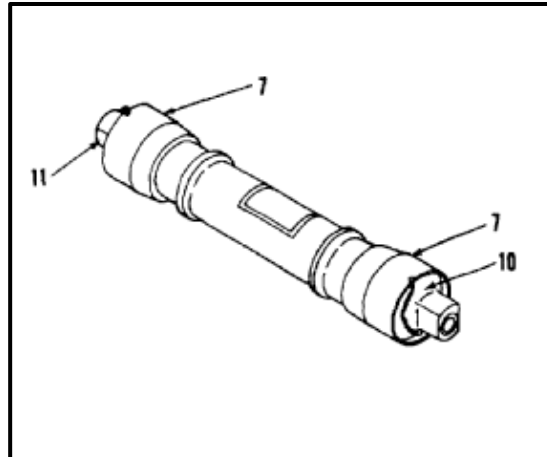
**FOLLOW-ON MAINTENANCE:**

None

END OF TASK

INITIAL SETUP

Applicable Configurations:

All

Tools:

- Hydraulic Repairer's Tool Kit, NSN 5180-00-323-4891
- Container, 2 Quart
- Hydraulic Test Stand
- Aluminum Dowel 3/8 Inch X 6 Inches
- Nitrogen Supply With Regulator
- Graduate, 10 cc
- Pressure Gage, 10 psi
- Pressure Gage, 2000 psi
- Pressure Gage, 5000 psi
- Shutoff Valve (4)
- Restrictor Valve
- Reservoir (APP E-11)
- Tube, 1/4 Inch, 0 to 5000 psi
- Nipples, 1/4 Inch (2)
- Tee, 1/4 Inch (4)
- Stop Watch

Materials:

- Hydraulic Fluid (E199)
- Cloth (E120)
- Gloves (E186)

Personnel Required:

- Aircraft Pneudraulics Repairer
- Inspector

References:

- TM 55-1520-240-23P
- Appendix E

Equipment Condition:

- Off Helicopter Task
- Accumulator Installed In Crash Proof Box
- Test Setup

General Safety Instructions:

WARNING

Use suitable crash box to shield personnel and equipment in case of failure during test.

WARNING

Hydraulic fluid (E199) is toxic. It can irritate skin and cause burns. Avoid inhaling. Use only with adequate ventilation. Avoid contact with skin, eyes, or clothing. In case of contact, immediately flush skin or eyes with water for at least **15 minutes**. Get medical attention for eyes.

WARNING

Hydraulic fluid ejected under pressure can cause injury to personnel. Hydraulic fluid sprayed into the air is a fire hazard.

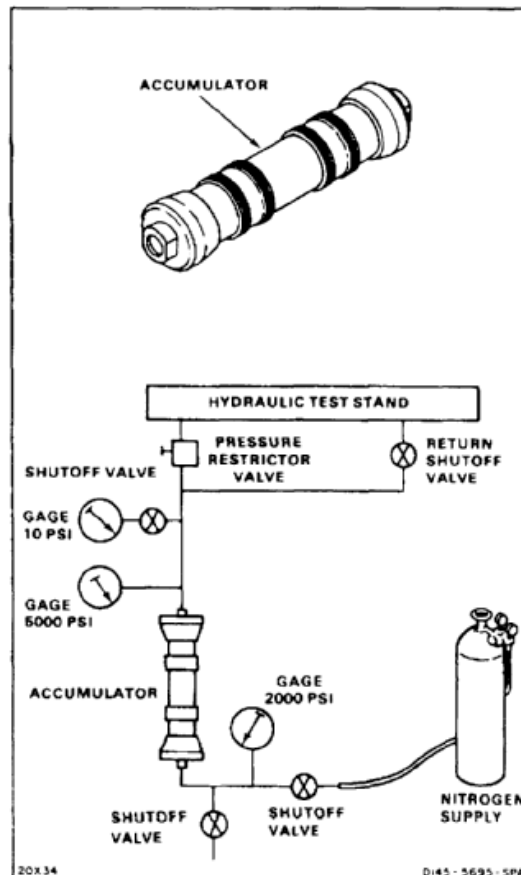

INTEGRITY PRESSURE TEST

1. Connect HYD port (1) of accumulator (2) to test setup (3).
2. Close valves (4 and 5).
3. Apply pressure to port (1). Adjust valve (6) for **4500 psi** on gage (7). Maintain pressure for **2 minutes**.
4. Check accumulator (2) for leaks. There shall be no leaks.
5. Reduce pressure to **0 psi** on gage (7). Close valve (6). Open valve (5).
6. Close valve (5).
7. Repeat steps 3 thru 6. Then perform step 8.

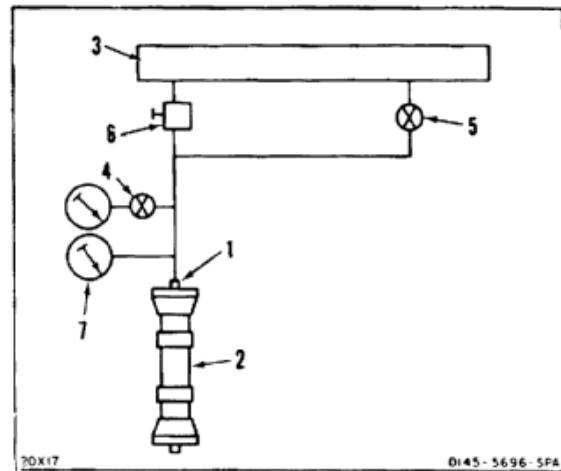
**FLUID LEAKAGE TEST**

8. Open valve (4). Apply pressure to HYD port (1). Adjust valve (6) for **2 psi** on gage (8). Maintain pressure for **2 hours**.
9. Check for leaks at port (9). Leaks shall not be more than **2 drops**.
10. Reduce pressure to **0 psi** on gage (8). Close valve (6). Open valve (5).
11. Close valves (4 and 5).
12. Apply pressure to port (1). Adjust valve (6) for **3000 psi** on gage (7). Maintain pressure for **30 minutes**.
13. Check for leaks at port (9). Leaks shall not be more than **1 drop**.
14. Reduce pressure to **0 psi** on gage (7). Close valve (6). Open valve (5).
15. Disconnect test setup (3) from port (1).

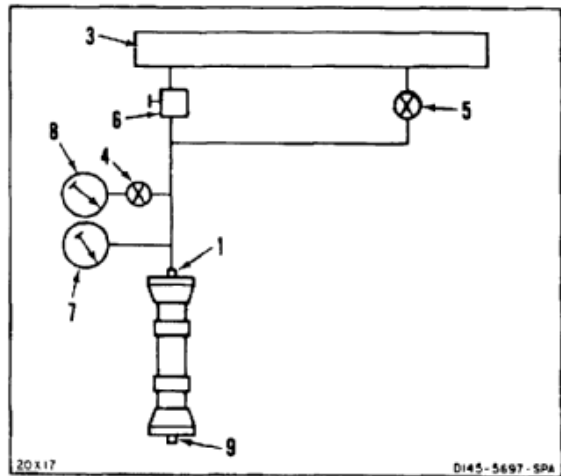

GAS LEAKAGE TEST

16. Insert dowel (10) through gas port (9) to contact piston of accumulator (2). Push dowel until piston bottoms. Remove dowel.
17. Connect reservoir (11) to port (1).
18. Fill reservoir (11) with fluid (E199) until tube (12) is covered. Use gloves (E186).

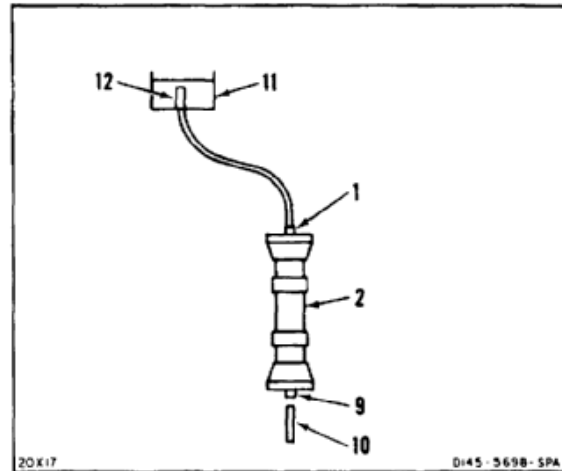

19. Position accumulator (2) on its side.
20. Connect nitrogen supply (13) to port (9).
21. Apply pressure to port (9). Open valve (14). Close valve (15). Adjust regulator (16) for **200 psi** on gage (17). Close valve (14).
22. Fill **10 cc** graduate (18) with fluid (E199). Place graduate over tube (12) in reservoir (11). Fluid level in graduate must be above fluid level in reservoir.
23. Record fluid level in graduate (18). Check fluid level after **1 hour**. Fluid level shall not change by more than **0.5 cc**.
24. Open valve (14). Adjust regulator (16) for **2000 psi** on gage (17). Close valve (14).
25. Repeat step 23. Then perform step 26.
26. Adjust regulator (16). Reduce pressure to **0 psi** on gage (17). Adjust regulator (15).
27. Remove graduate (18) from reservoir (11).
28. Disconnect reservoir (11) from port (1). Use container and cloths (E120) for spilled fluid.

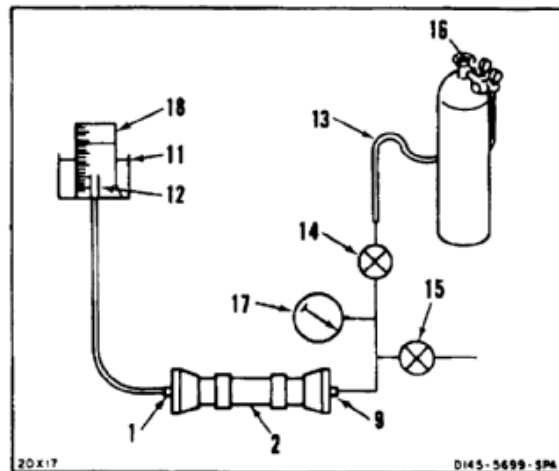
**WARNING**

Deplete air pressure before disconnecting tubes or hoses. Otherwise, injury to personnel can occur.

29. Open valve (15). Disconnect supply (13) from port (9).

INSPECT**FOLLOW-ON MAINTENANCE:**

None

END OF TASK

INITIAL SETUP

Applicable Configurations:

All

Tools:

Aircraft Mechanic's Tool Kit, NSN 1580-00-323-4692
 Crowfoot Attachment, 3/4 Inch
 Crowfoot Attachment, 1 Inch
 Torque Wrench, 30 to 150 Inch-Pounds

Materials:

Lockwire (E231)

Parts:

Preformed Packing

Personnel Required:

Medium Helicopter Repairer
 Inspector

References:

TM 55-1520-240-23P

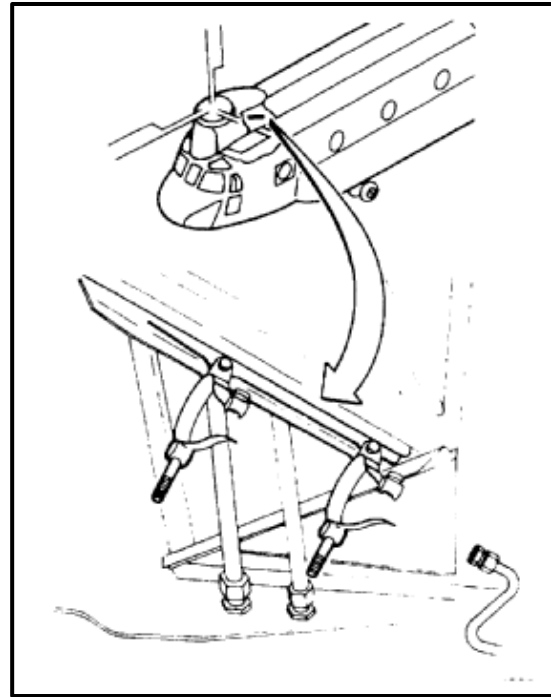

1. Install valve and gage assembly (1), union (2), and packing (3) in accumulator (4).
2. Install reducer (5) and packing (6) in accumulator (4). Torque reducer to **135 inch-pounds**.

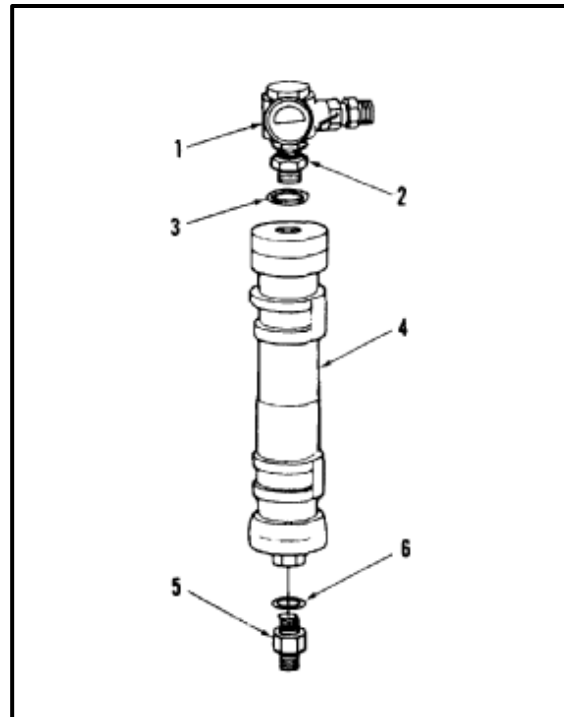

3. Position accumulator (4) in two clamps (7).
4. Close two clamps (7) and install two nuts (8). Do not tighten nuts at this time.
5. Connect tube (9) to reducer (5).
6. Torque nuts (8) to **22 inch-pounds**. Lockwire clamps (7). Use lockwire (E231).
7. Loosen nut (10).
8. Position valve and gage assembly (1) so that valve (11) faces outboard at **4 o'clock** position.
9. Torque nut (10) to **135 inch-pounds**.

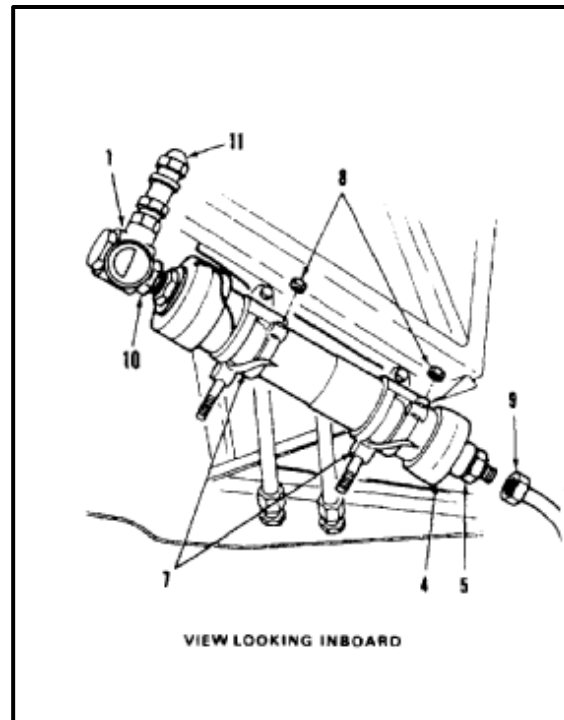
INSPECT**FOLLOW-ON MAINTENANCE:**

- Service utility hydraulic system (Task 1-59 or 1-62).
- Service wheel brake accumulator (Task 1-67).
- Bleed brake hydraulic system (Task 7-330).
- Perform operational check (TM 55-1520-240-T).
- Close left forward fairing work platform (Task 2-2).

END OF TASK

INITIAL SETUP

Applicable Configurations:

All

Tools:

Aircraft Mechanic's Tool Kit, NSN 51 80-00-323-4692
Workstand

Materials:

Cloths (E120)
Paper Tags (E264)
Gloves (E186)

Personnel Required:

Medium Helicopter Repairer

Equipment Condition:

Battery Disconnected (Task 1-39)
Electrical Power Off
Hydraulic Power Off
Utility Hydraulic System Depressurized (Task 7-135.1)
Cargo Ramp Open and Level (TM 55-1520-240-T)

General Safety Instructions:**WARNING**

Hydraulic fluid (E199) is toxic. It can irritate skin and cause burns. Avoid inhaling. Use only with adequate ventilation. Avoid contact with skin, eyes, or clothing. In case of contact, immediately flush skin or eyes with water for at least **15 minutes**. Get medical attention for eyes.

WARNING

Hydraulic fluid ejected under pressure can cause injury to personnel. Hydraulic fluid sprayed into the air is a fire hazard.

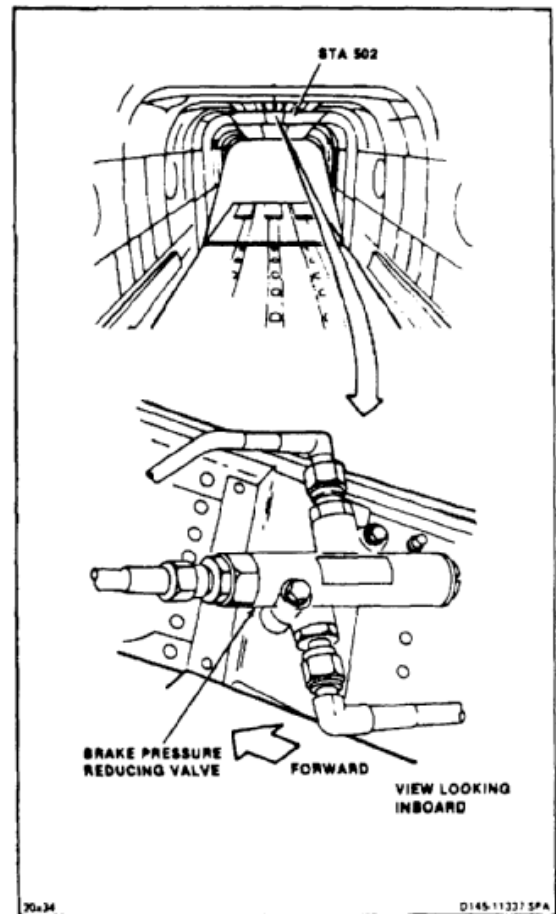

1. Tag and disconnect three tubes (1) from brake pressure reducing valve (2). Use cloths (E120) for spilled fluid. Use gloves (E186).
2. Remove two bolts (3) washers (4), and spacers (5) from valve (2). Remove valve.

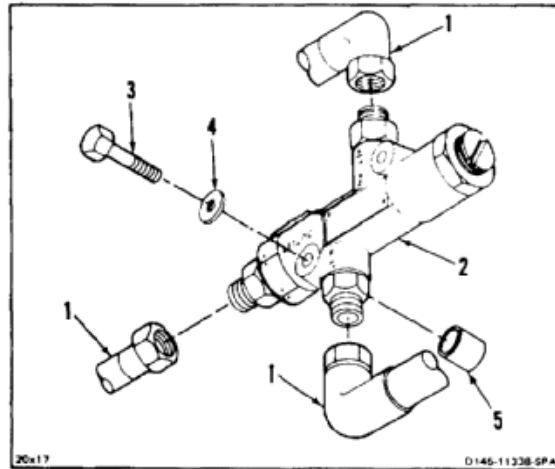

3. Remove three nipples (6) and packings (7) from valve (2).

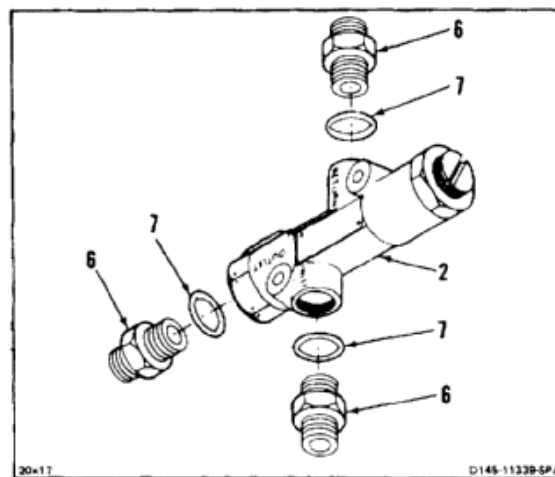

FOLLOW-ON MAINTENANCE:

None

END OF TASK

INITIAL SETUP

Applicable Configurations:

All

Tools:

Aircraft Mechanic's Tool Kit, NSN 51 80-00-323-4692
Workstand

Materials:

None

Parts:

Preformed Packing

Personnel Required:

Medium Helicopter Repairer
Inspector

References:

TM 55-1520-240-23P

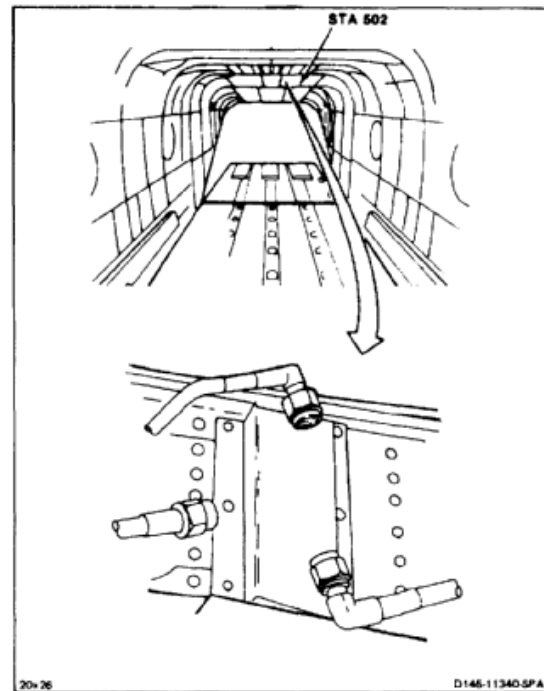

1. Install packing (1) and nipple (2) in OUTLET port (3) of valve (4).
2. Install packing (5) and nipple (6) in INLET port (7) of valve (4).
3. Install packing (8) and nipple (9) in RETURN port (10) of valve (4).

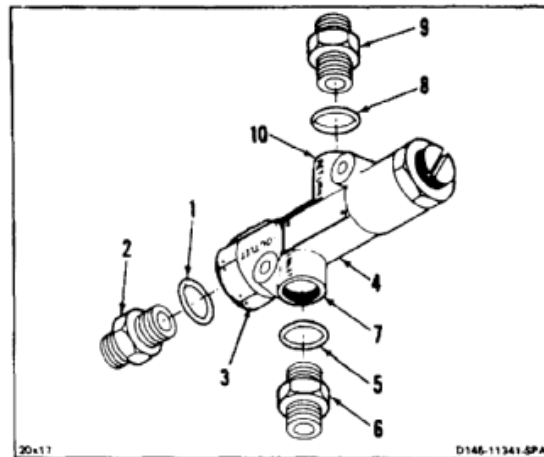

4. Position valve (4) on mount (11), OUTLET port (3) forward, and RETURN port (10) up. Install two bolts (12), spacers (13), and washers (14) in mount.
5. Connect tube (15) to port (3). Remove tag.
6. Connect tube (16) to port (7). Remove tag.
7. Connect tube (17) to port (10). Remove tag.

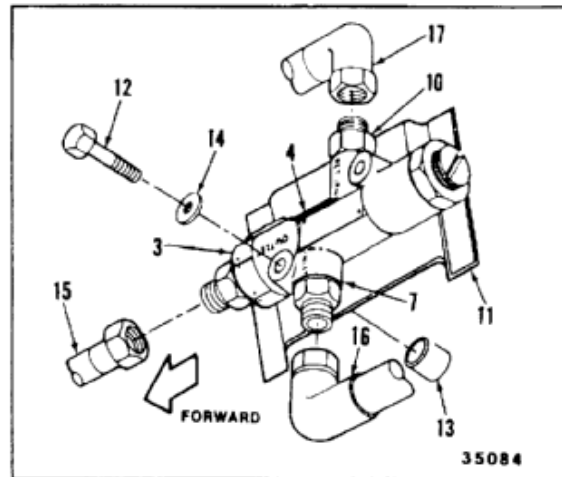
INSPECT**FOLLOW-ON MAINTENANCE:**

- Service utility hydraulic system (Task 1-59 or 1-62).
- Perform operational check of hydraulic brake system (TM 55-1520-240-T).
- Close ramp (TM 55-1520-240-10).

END OF TASK

7-918

7-247 REMOVE WINCH MOTOR

7-247

INITIAL SETUP**Applicable Configurations:**

All

Tools:

Aircraft Mechanic's Tool Kit, NSN 51 80-00-323-4692
Container, 2 Quart

Materials:

Cloths (E135)
Gloves (E186)

Personnel Required:

Medium Helicopter Repairer (2)

Equipment Condition:

Battery Disconnected (Task 1-39)
Electrical Power Off
Hydraulic Power Off
Utility Hydraulic System Depressurized (Task 7-135.1)
Heater Compartment Acoustic Blanket Removed
(Task 2-208)

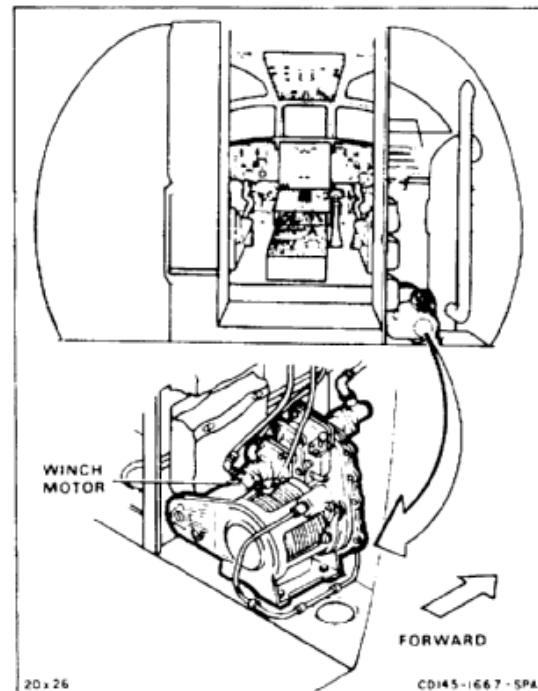
**General Safety Instructions:****WARNING**

Hydraulic fluid (E199) is toxic. It can irritate skin and cause burns. Avoid inhaling. Use only with adequate ventilation. Avoid contact with skin, eyes, or clothing. In case of contact, immediately flush skin or eyes with water for at least **15 minutes**. Get medical attention for eyes.

WARNING

Hydraulic fluid ejected under pressure can cause injury to personnel. Hydraulic fluid sprayed into the air is a fire hazard.

1. Tag and disconnect three hoses (1) from motor (2). Use container and cloth (E135) for spilled fluid. Use gloves (E186).
2. Loosen three nuts (3) on elbows (4).

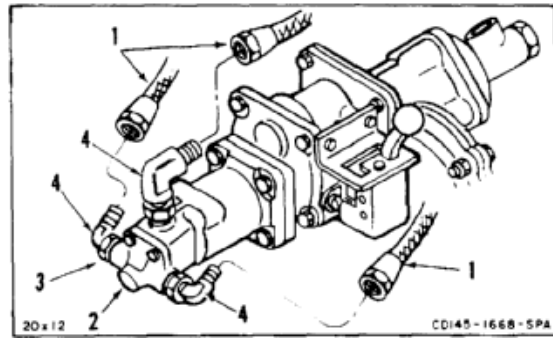

3. Remove three elbows (4), packing (5), and washers (6).

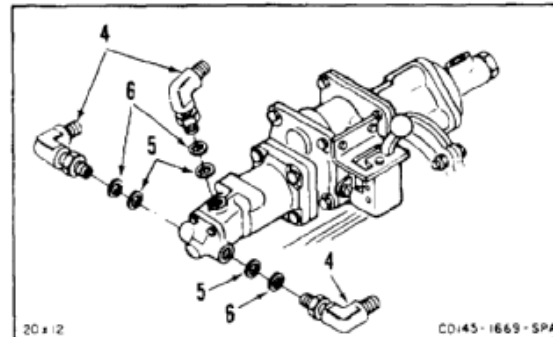

4. Remove four nuts (7), eight washers (8), and four bolts (9). Remove motor (2).

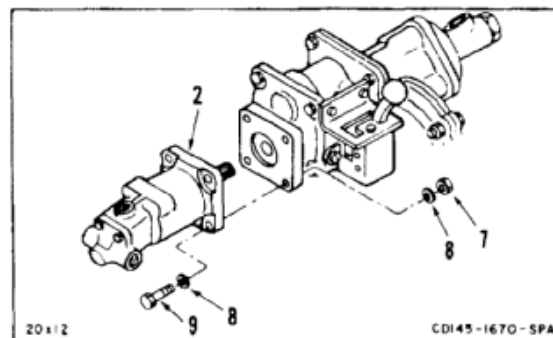

FOLLOW-ON MAINTENANCE:

None

END OF TASK

7-920

INITIAL SETUP

Applicable Configurations:

All

Tools:

Aircraft Mechanic's Tool Kit, NSN 5180-00-323-4692

Materials:

Dry Cleaning Solvent (E162)
 Sealant (E330)
 Cloth (E135)
 Grease (E189)
 Gloves (E186)

Parts:

Preformed Packings
 Nonmetallic Washers

Personnel Required:

Medium Helicopter Repairer (2)
 Inspector

References:

TM 55-1520-240-23-P

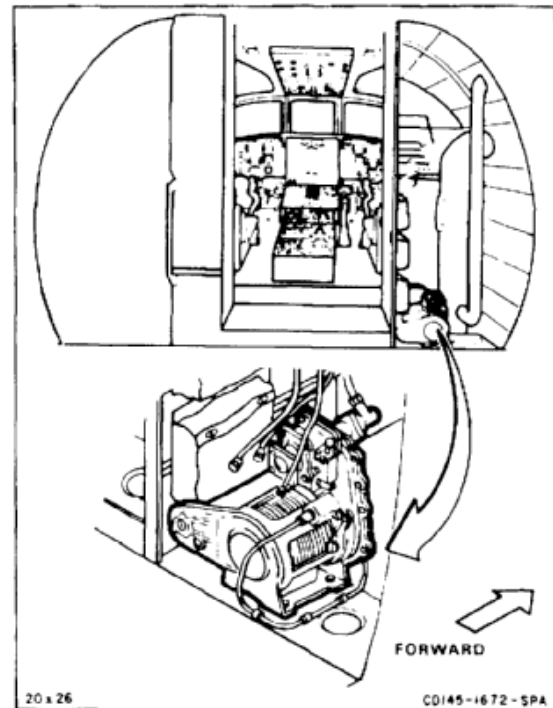
**WARNING**

Solvent (E162) is flammable and toxic. It can irritate skin and cause burns. Avoid contact with skin and eyes. Use only in well-ventilated area away from heat and open flame. In case of contact, immediately flush skin or eyes with water for at least **15 minutes**. Get medical attention for eyes.

1. Clean mounting surface of flange (1) and surface of winch motor (2). Use solvent (E162) and cloths (E135). Wear gloves (E186).

WARNING

Sealant (E330) can irritate skin and cause burns. Avoid contact with skin, eyes, and clothing. In case of contact, immediately flush skin or eyes with water for at least **15 minutes**. Get medical attention for eyes.

2. Lightly coat mounting surface of winch motor (2) and flange (1) with sealant (E330).
3. Lightly coat spline (3) with grease (E189).

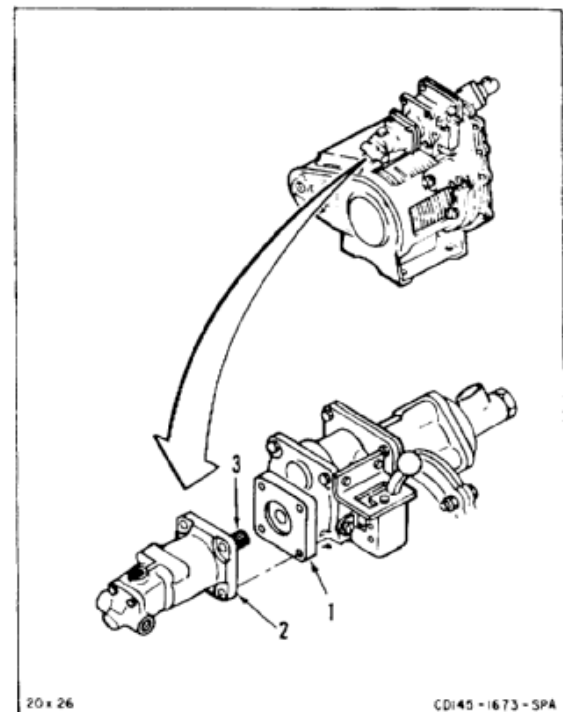

4. Position motor (2) on flange (1) as shown. Install four bolts (4), eight washers (5), and four nuts (6).

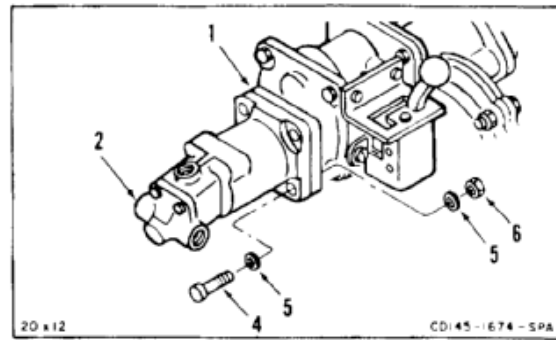

5. Install washers (7) and packings (8) on three elbows (9).
6. Install three elbows (9). Do not tighten nuts (10) at this time.

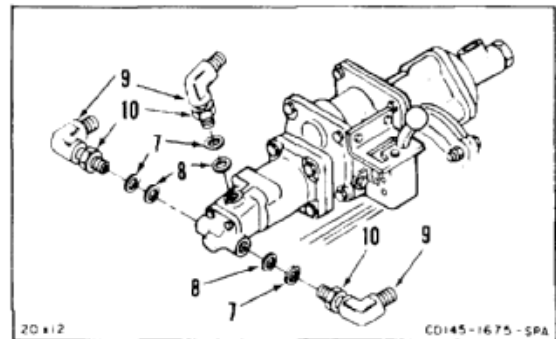

7. Connect three hoses (11). Remove tags.
8. Tighten nuts (10).

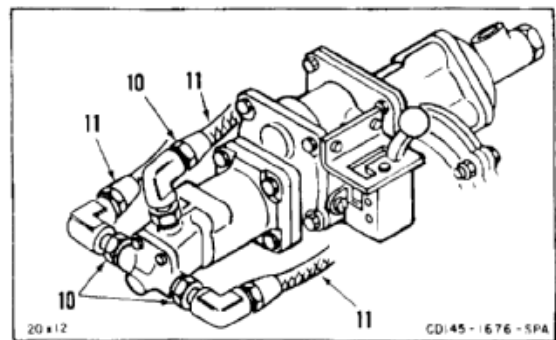

INSPECT

FOLLOW-ON MAINTENANCE:

Bleed utility hydraulic winch system (Task 7-333).
 Check operation of winch motor (TM 55-1520-240-T).
 Install heater compartment acoustic blanket (Task 2-210).

END OF TASK

7-922

7-249 REMOVE HOIST CONTROL VALVE

7-249

INITIAL SETUP**Applicable Configurations:**

All

Tools:

Aircraft Mechanic's Tool Kit, NSN 51 80-00-323-4692
Container, 2 Quart

Materials:

Cloths (E135)
Paper Tags (E264)
Gloves (E186)

Personnel Required:

Medium Helicopter Repairer

Equipment Condition:

Battery Disconnected (Task 1-39)
Electrical Power Off
Hydraulic Power Off
Utility Hydraulic System Depressurized (Task 7-135.1)
Heater Compartment Acoustic Blanket Removed
(Task 2-208)

General Safety Instructions:**WARNING**

Hydraulic fluid (E199) is toxic. It can irritate skin and cause burns. Avoid inhaling. Use only with adequate ventilation. Avoid contact with skin, eyes, or clothing. In case of contact, immediately flush skin or eyes with water for at least **15 minutes**. Get medical attention for eyes.

WARNING

Hydraulic fluid ejected under pressure can cause injury to personnel. Hydraulic fluid sprayed into the air is a fire hazard.

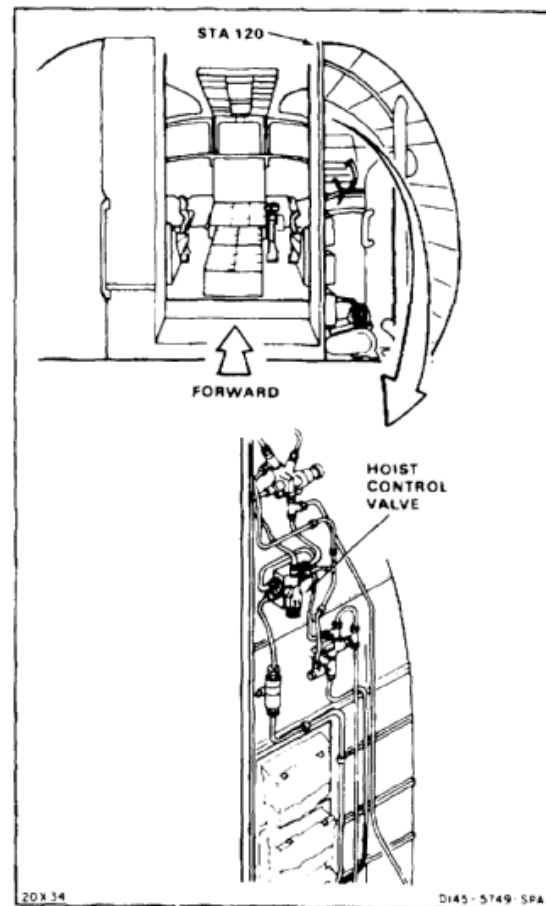

1. Disconnect electrical plug (1) from valve (2).
2. Tag and disconnect four tubes (3). Use container and cloths (E135) for spilled fluid.
3. Remove two bolts (4) and washers (5).
4. Remove valve (2).

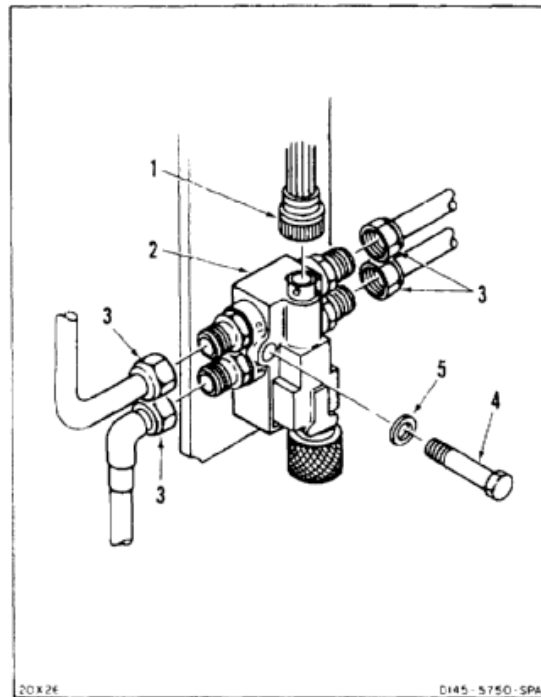

5. Remove four nipples (6), and packings (7).

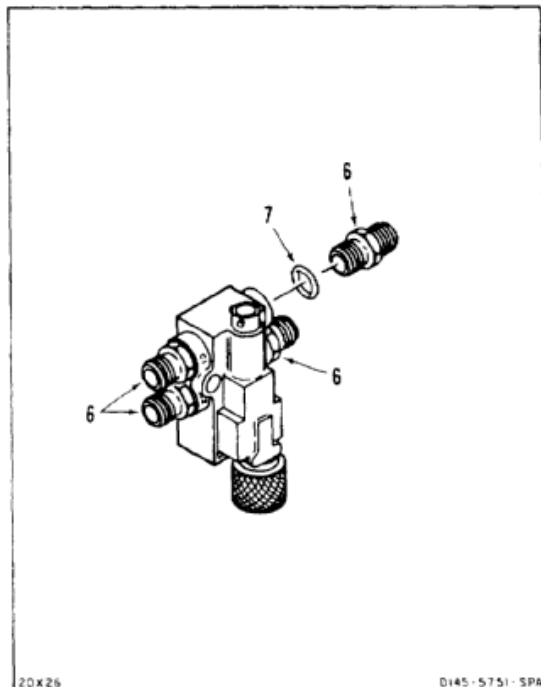
**FOLLOW-ON MAINTENANCE:**

None

END OF TASK

7-924

INITIAL SETUP

Applicable Configurations:

All

Tools:

Aircraft Mechanic's Tool Kit, NSN 51 80-00-323-4692

Materials:

None

Parts:

Preformed Packings

Personnel Required:

Medium Helicopter Repairer
Inspector

References:

TM 55-1520-240-23P

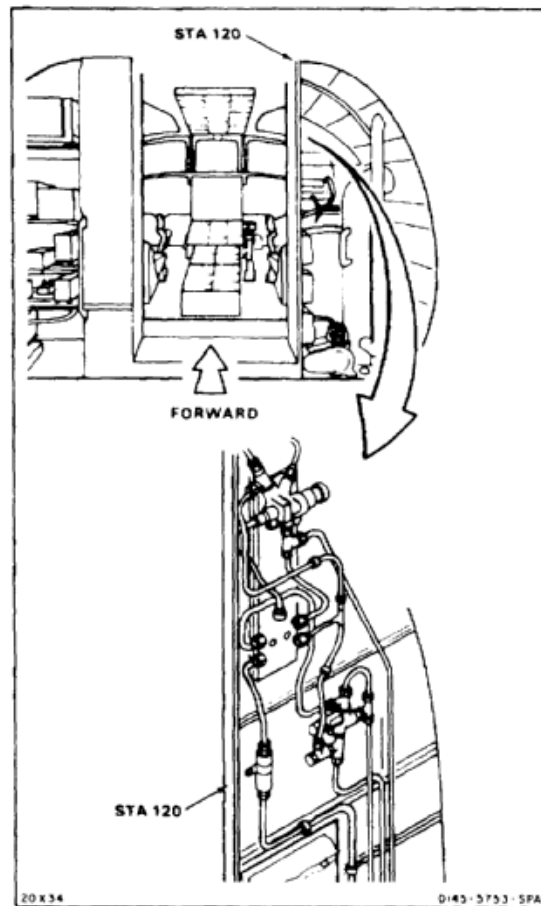

1. Install four nipples (1) and packings (2), one of each in port C1 (3), port C2 (4), port P (5), and port R (6).

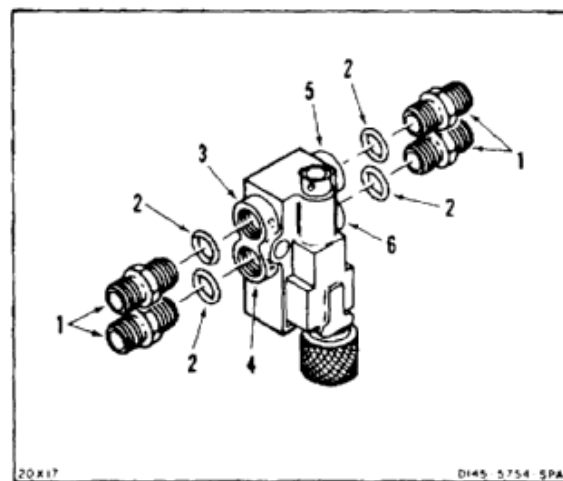

2. Position valve (7) on structure with receptacle (8) up. Install two bolts (9) and washers (10).

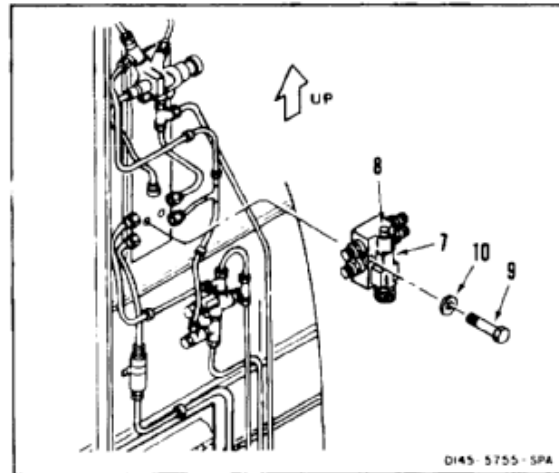

3. Connect electrical plug (11) to receptacle (8).
4. Connect tube (12) to port C1 (3). Remove tag.
5. Connect tube (13) to port C2 (4). Remove tag.
6. Connect tube (14) to port P (5). Remove tag.
7. Connect tube (15) to port R (6). Remove tag.

INSPECT

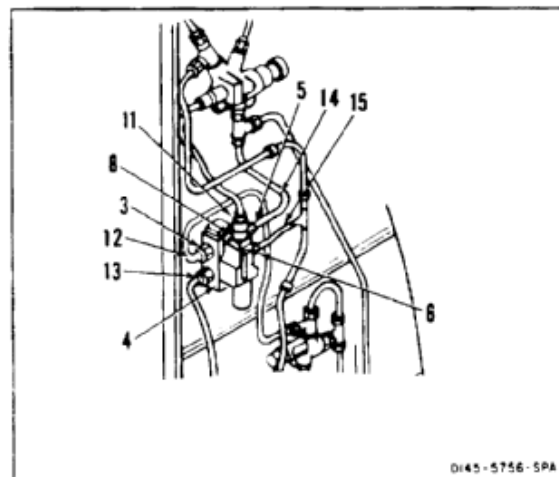

FOLLOW-ON MAINTENANCE:

- Service utility hydraulic system (Task 1-59 or 1-62).
- Perform operational check of hoist (TM 55-1520-240-T).
- Install heater compartment acoustic blanket (Task 2-210).

END OF TASK

7-251 REMOVE HOIST CONTROL SHUTOFF VALVE

7-251

INITIAL SETUP**Applicable Configurations:**

All

Tools:

Aircraft Mechanic's Tool Kit, NSN 51 80-00-323-4692
Container, 2 Quart

Materials:

Cloths (E135)
Paper Tags (E264)
Gloves (E186)

Personnel Required:

Medium Helicopter Repairer

Equipment Condition:

Battery Disconnected (Task 1-39)
Electrical Power Off
Hydraulic Power Off
Utility Hydraulic System Depressurized (Task 7-135.1)
Heater Compartment Acoustic Blanket Removed
(Task 2-208)

General Safety Instructions:**WARNING**

Hydraulic fluid (E199) is toxic. It can irritate skin and cause burns. Avoid inhaling. Use only with adequate ventilation. Avoid contact with skin, eyes, or clothing. In case of contact, immediately flush skin or eyes with water for at least **15 minutes**. Get medical attention for eyes.

WARNING

Hydraulic fluid ejected under pressure can cause injury to personnel. Hydraulic fluid sprayed into the air is a fire hazard.

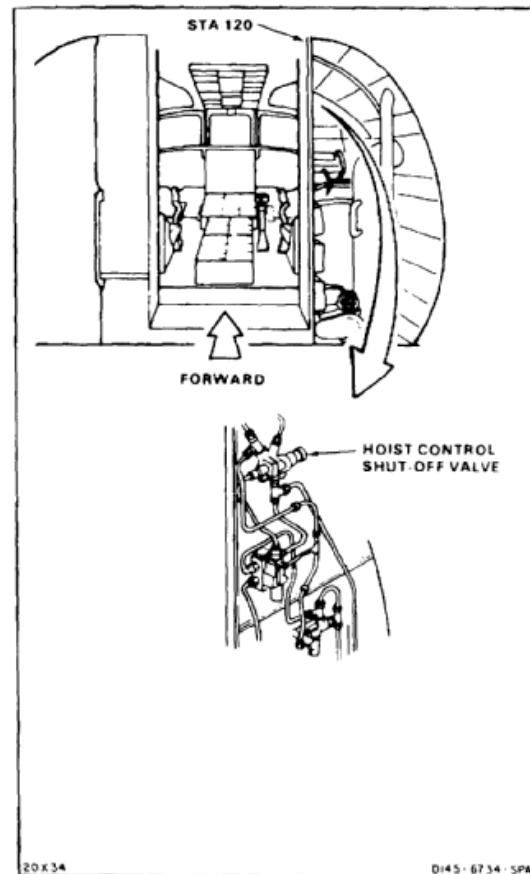

1. Tag and disconnect electrical plug (1) from valve (2).
2. Tag and disconnect tube (3) from tee (4). Use container and cloths (E135) for spilled fluid. Use gloves (E186).
3. Tag and disconnect tube (5) from valve (6). Use container and cloths (E135) for spilled fluid.
4. Tag and disconnect tube (7) from valve (2). Use container and cloths (E135) for spilled fluid.
5. Tag and disconnect tee (8) from valve (2). Use container and cloths (E135) for spilled fluid.
6. Remove three bolts (9) and washers (10).
7. Remove valve (2).

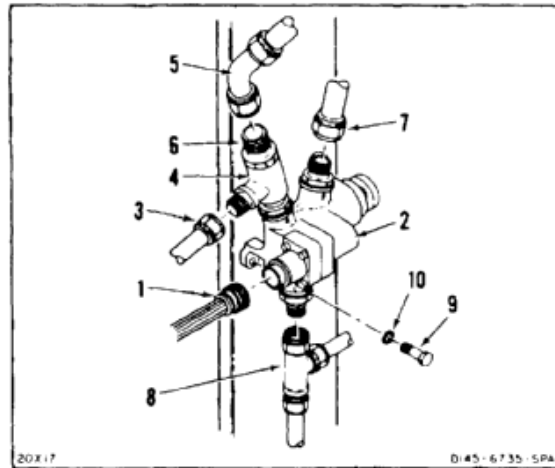

8. Loosen nut (11). Remove tee (4), packing (12), and retainer (13) from R port (14).
9. Remove nipple (15) and packing (16) from port P (17).
10. Remove nipple (18) and packing (19) from port C (20).

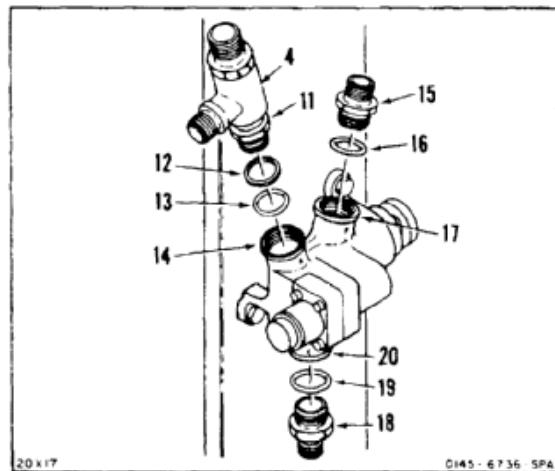

FOLLOW-ON MAINTENANCE:

None

END OF TASK

INITIAL SETUP

Applicable Configurations:

All

Tools:

Aircraft Mechanic's Tool Kit, NSN 51 80-00-323-4692

Materials:

None

Parts:

Preformed Packings
Retainer

Personnel Required:

Medium Helicopter Repairer
Inspector

References:

TM 55-150-240-23P

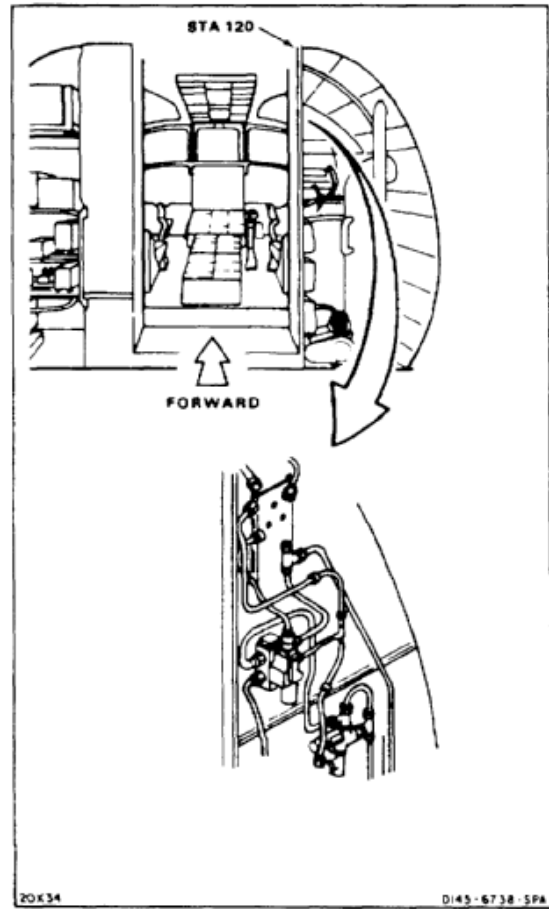

1. Install tee (1), packing (2), and retainer (3) in port R (4). Tighten nut (5).
2. Install nipple (6) and packing (7) in port P (8).
3. Install nipple (9) and packing (10) in port C (11).

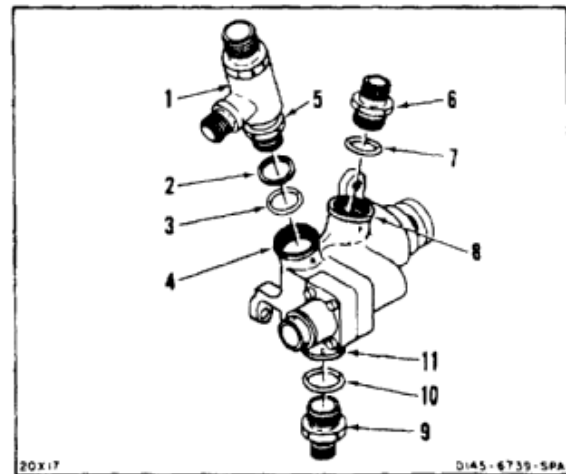

4. Position valve (12) on mount (13). Install three bolts (14) and washers (15).
5. Connect tube (16) to nipple (6). Remove tag.
6. Connect tee (17) to nipple (9). Remove tag.
7. Connect tube (18) to tee (1). Remove tag.
8. Connect tube (19) to valve (20). Remove tag.
9. Connect electrical plug (21) to valve (12). Remove tag.

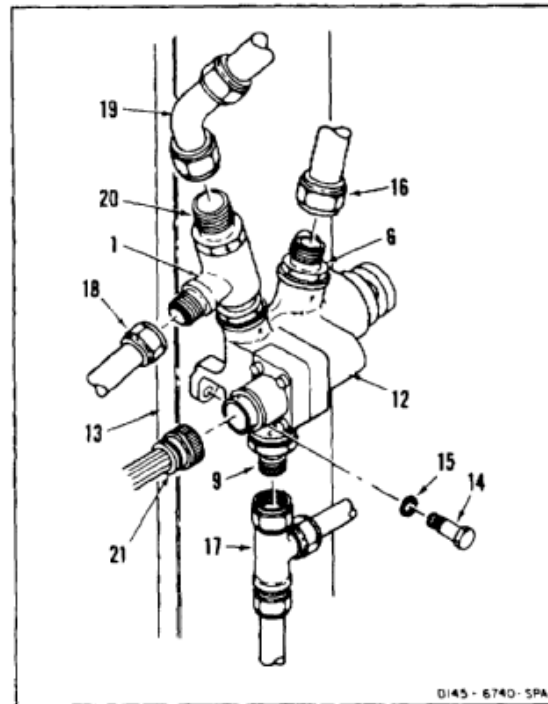
INSPECT**FOLLOW-ON MAINTENANCE:**

- Service utility hydraulic system (Task 1-59 or 1-62).
- Perform operational check of hoist (TM 55-1520-240-T).
- Install heater compartment acoustic blanket (Task 2-210).

END OF TASK

INITIAL SETUP

Applicable Configurations:

All

Tools:

Aircraft Mechanic's Tool Kit, NSN 51 80-00-323-4692

Materials:Cloths (E120)
Gloves (E186)**Personnel Required:**

Medium Helicopter Repairer

Equipment Condition:Battery Disconnected (Task 1-39)
Electrical Power Off
Hydraulic Power Off
Utility Hydraulic System Depressurized (Task 7-135.1)
Heater Compartment Acoustic Blanket Removed
(Task 2-208)**General Safety Instructions:****WARNING**

Hydraulic fluid (E199) is toxic. It can irritate skin and cause burns. Avoid inhaling. Use only with adequate ventilation. Avoid contact with skin, eyes, or clothing. In case of contact, immediately flush skin or eyes with water for at least **15 minutes**. Get medical attention for eyes.

WARNING

Hydraulic fluid ejected under pressure can cause injury to personnel. Hydraulic fluid sprayed into the air is a fire hazard.

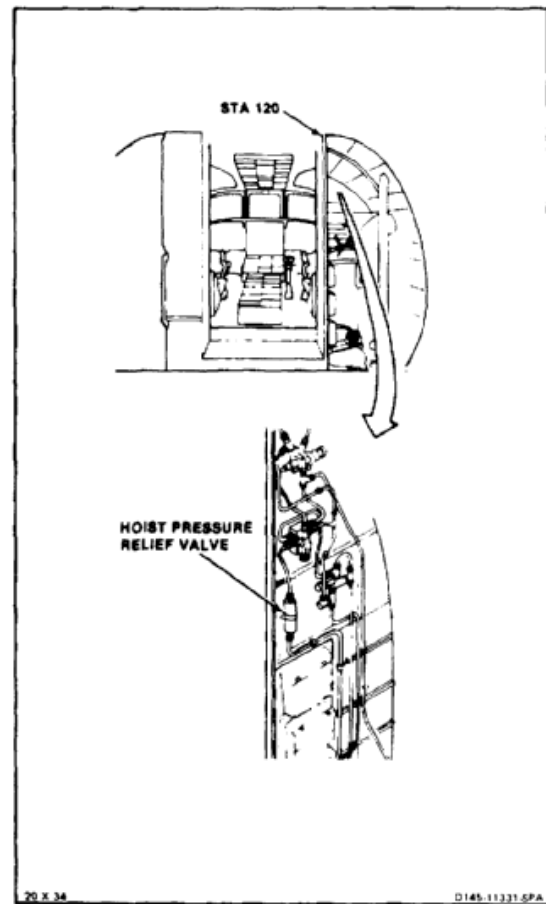

1. Remove two tubes (1) from pressure relief valve (2). Use cloths (E120) for spilled fluid. Use gloves (E186).
2. Remove screw (3) and washer (4) from clamp (5). Remove valve (2).

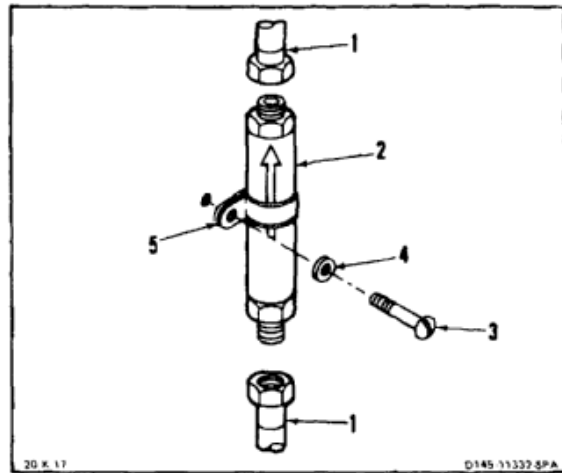

3. Remove two reducers (6) and packings (7) from valve (2).
4. Remove clamp (5) from valve (2).

FOLLOW-ON MAINTENANCE:

None

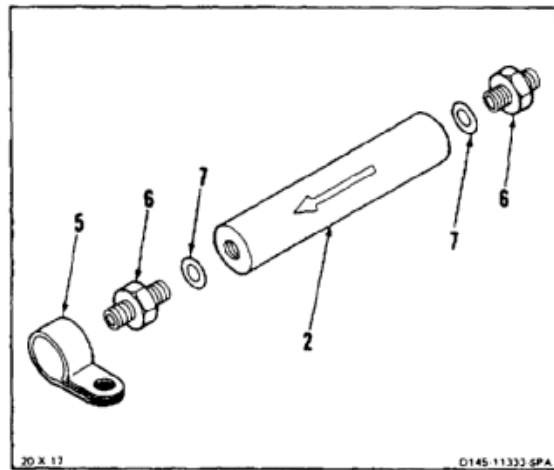

END OF TASK

7-932

INITIAL SETUP

Applicable Configurations:

All

Tools:

Aircraft Mechanic's Tool Kit, NSN 51 80-00-323-4692

Materials:

None

Parts:

Preformed Packing

Personnel Required:

Medium Helicopter Repairer
Inspector

References:

TM 55-1520-240-23P

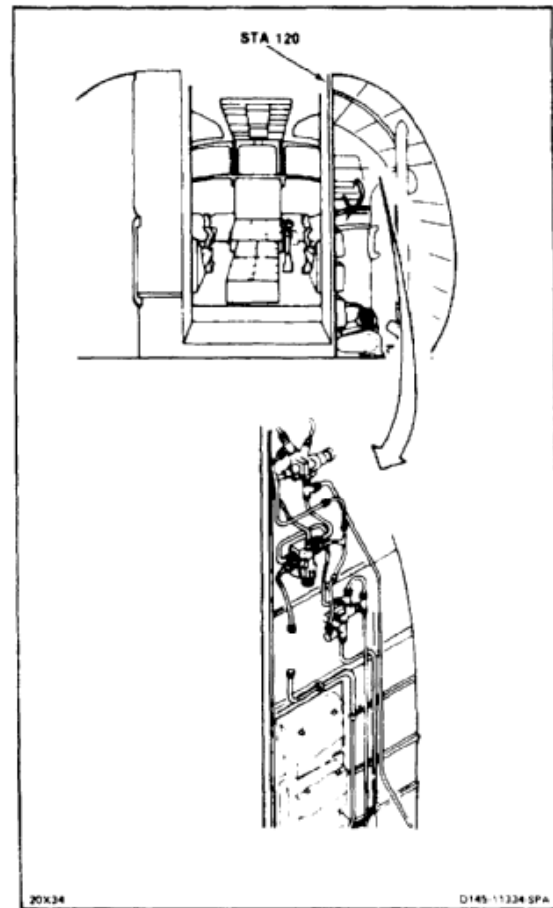

1. Slide clamp (1) on pressure relief valve (2).
2. Install two reducers (3) and packings (4) on valve (2).

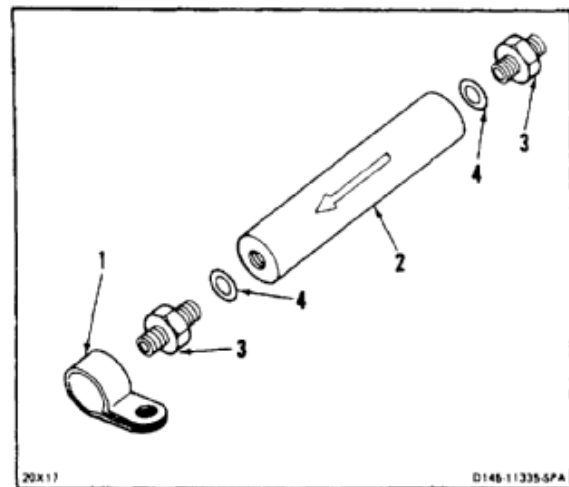

3. Position valve (2) on structure (5), clamp (1) pointing aft and arrow (6) up. Connect two tubes (7 and 8) to valve.
4. Install screw (9) and washer (10) in clamp (1) and structure (5).

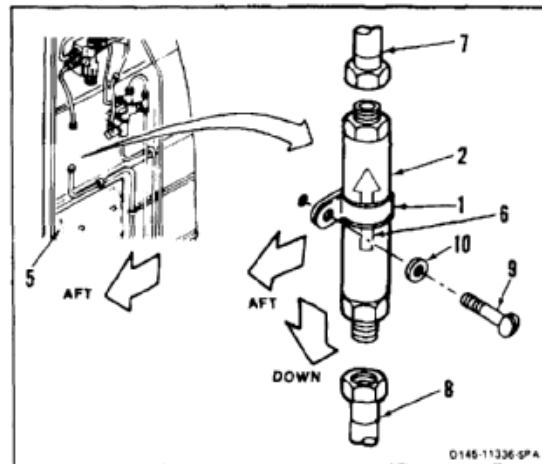
INSPECT**FOLLOW-ON MAINTENANCE:**

- Service utility hydraulic system (Task 1-59 or 1-62).
- Perform operational check of hoist (TM 55-1520-240-T).
- Install heater compartment acoustic blanket (Task 2-210).

END OF TASK

7-934

INITIAL SETUP

Applicable Configurations:

All

Tools:

Aircraft Mechanic's Tool Kit, NSN 51 80-00-323-4692

Materials:

Cloths (E120)
 Paper Tags (E264)
 Gloves (E186)

Personnel Required:

Medium Helicopter Repairer

Equipment Condition:

Battery Disconnected (Task 1-39)
 Electrical Power Off
 Hydraulic Power Off
 Utility Hydraulic System Depressurized (Task 7-135.1)
 Heater Compartment Acoustic Blanket Removed
 (Task 2-208)

General Safety Instructions:**WARNING**

Hydraulic fluid (E199) is toxic. It can irritate skin and cause burns. Avoid inhaling. Use only with adequate ventilation. Avoid contact with skin, eyes, or clothing. In case of contact, immediately flush skin or eyes with water for at least **15 minutes**. Get medical attention for eyes.

WARNING

Hydraulic fluid ejected under pressure can cause injury to personnel. Hydraulic fluid sprayed into the air is a fire hazard.

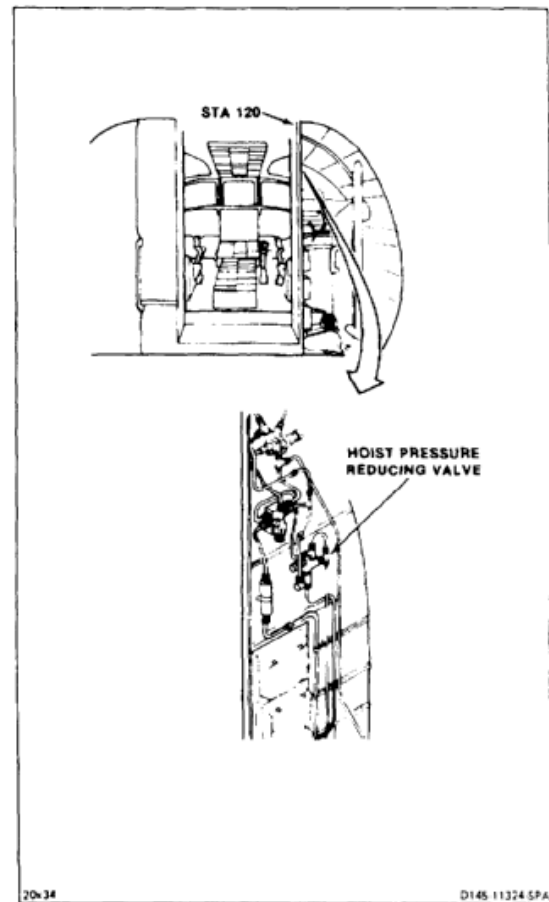

1. Tag and disconnect five tubes (1) from reducing valve (2). Use cloths (E120) for spilled fluid. Use gloves (E186).
2. Remove two bolts (3) and washers (4) from valve (2).
3. Remove valve (2).

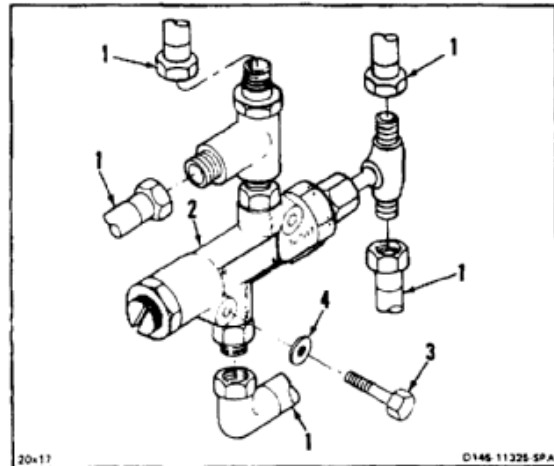

4. Loosen nut (5). Remove tee (6), packing (7), and washer (8) from valve (2).
5. Remove nipple (9) and packing (10) from valve (2).
6. Disconnect tee (11) from valve (2).

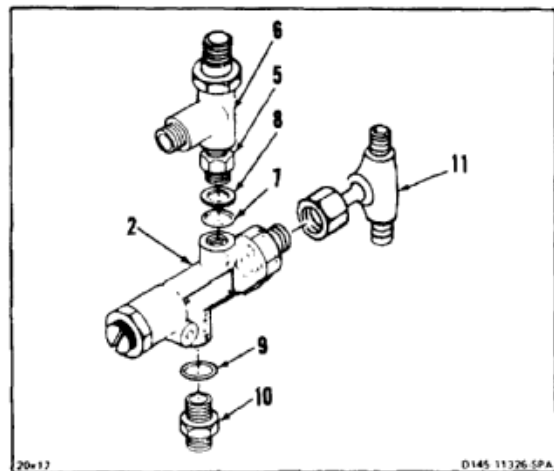

FOLLOW-ON MAINTENANCE:

None

END OF TASK

7-936

INITIAL SETUP

Applicable Configurations:

All

Tools:

- Hydraulic Repairer's Tool Kit, NSN 5180-00-323-4891
- Soft Jawed Vise
- Open End Wrench, 1 Inch
- Wood Dowel, 5/16 Inch X 6 Inches
- Technical Inspection Tool Kit, NSN 5180-00-323-5114

Materials:

None

Personnel Required:

- Aircraft Pneudraulics Repairer
- Inspector

References:

Task 7-1.1

Equipment Condition:

Off Helicopter Task

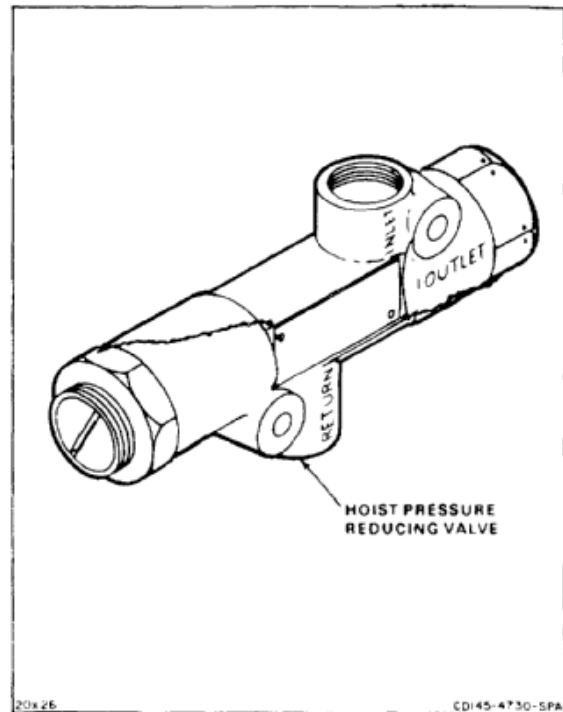

NOTE

General inspection criteria (Task 7-1.1) for obvious damage applies unless otherwise stated.

Inspection steps cover parts that are subject to wear.

1. Remove lockwire from fitting (1).
2. Position valve body (2) in soft jawed vise (3), fitting (1) up.
3. Remove fitting (1) and spring (4) from body (2).
4. Remove washer (5), packings (6 and 7), and retainer (8) from fitting (1).

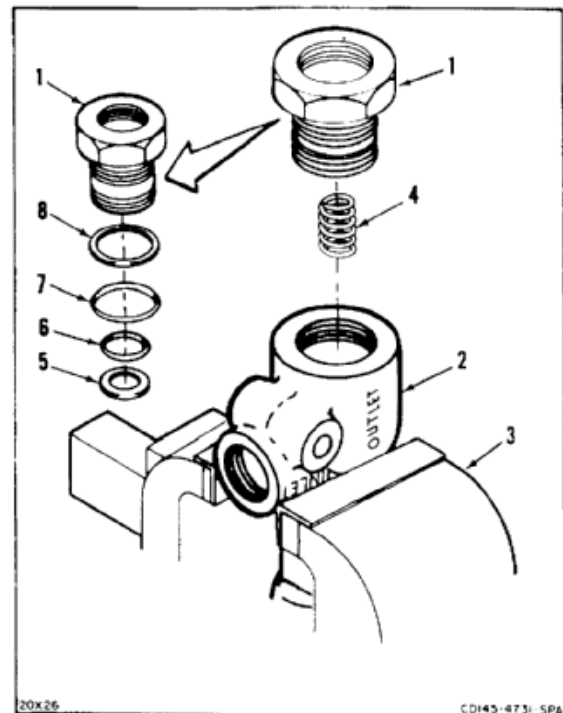

7-256 DISASSEMBLE AND INSPECT HOIST PRESSURE REDUCING VALVE (AVIM) (Continued)

5. Remove body (2) from vise (3). Turn body **180°** and position it in vise, valve cap (9) up.
6. Remove sealant from slot in cap (9).
7. Remove lockwire from locknut (10). Loosen nut and remove cap (9) from body (2).
8. Remove locknut (10), packing (11), and retainer (12) from cap (9).
9. Remove spring (13), washer (14), and seat (15) from body (2).
10. Remove body (2) from vise (3).

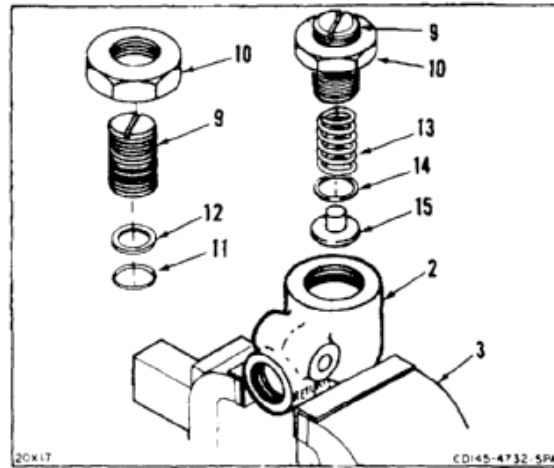

11. Insert wood dowel (16) into port (17).
12. Press dowel (16) against plunger (18) and remove selector sleeve (19) from outlet port (20). Remove dowel.

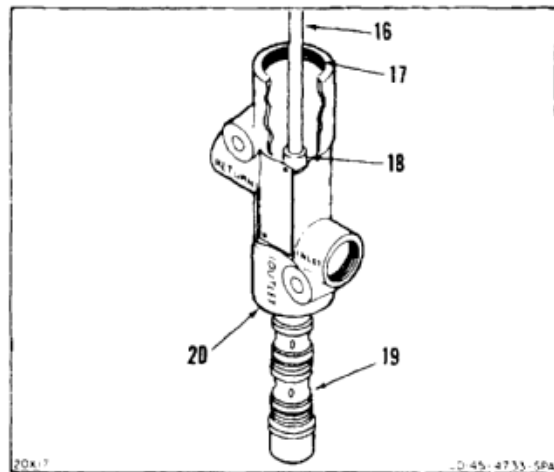

7-256 DISASSEMBLE AND INSPECT HOIST PRESSURE REDUCING VALVE (AVIM) (Continued)

7-256

13. Remove selector slide (21) and retainer (22) from selector sleeve (19).
14. Remove plunger (18), ball (23), and seat (24) from selector sleeve (19).
15. Remove retainer (25) and packing (26) from seat (24).
16. Remove three retainers (27) and two packings (28) from selector sleeve (19).
17. Insert seat (24) and plunger (18) in selector sleeve (19). Seat and plunger shall move freely in bore of sleeve.

NOTE

Selector slide and selector sleeve are a matched set. If one is damaged, both must be replaced.

18. Insert selector slide (21) in selector sleeve (19). Slide shall move freely in bore of sleeve.
19. Inspect large diameter (29) and tapered shoulder (30) of selector slide (21). There shall be no nicks or scratches.

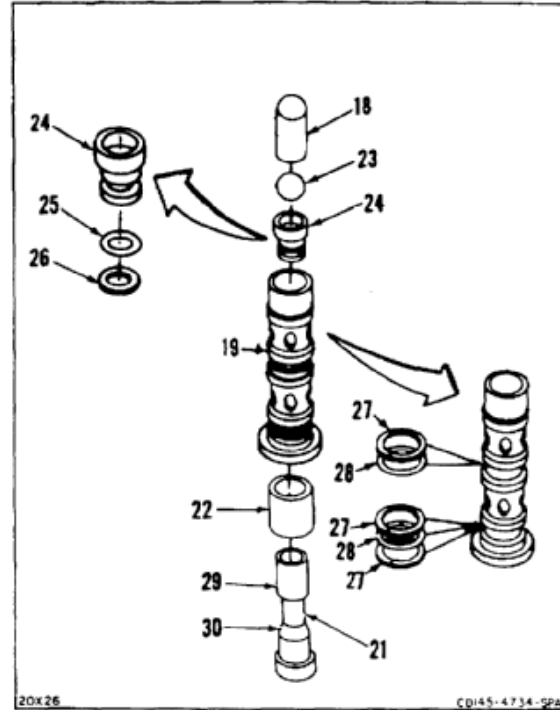
FOLLOW-ON MAINTENANCE:

None

END OF TASK

INITIAL SETUP

Applicable Configurations:

All

Tools:

- Hydraulic Repairer's Tool Kit, NSN 5180-00-323-4891
- Soft Jawed Vise
- Open End Wrench, 1 Inch
- Torque Wrench, 100 to 750 Inch-Pounds

Materials:

Lockwire (E231)

Parts:

- Packings
- Retainers

Personnel Required:

- Aircraft Pneudraulics Repairer
- Inspector

References:

TM 55-1520-240-23P

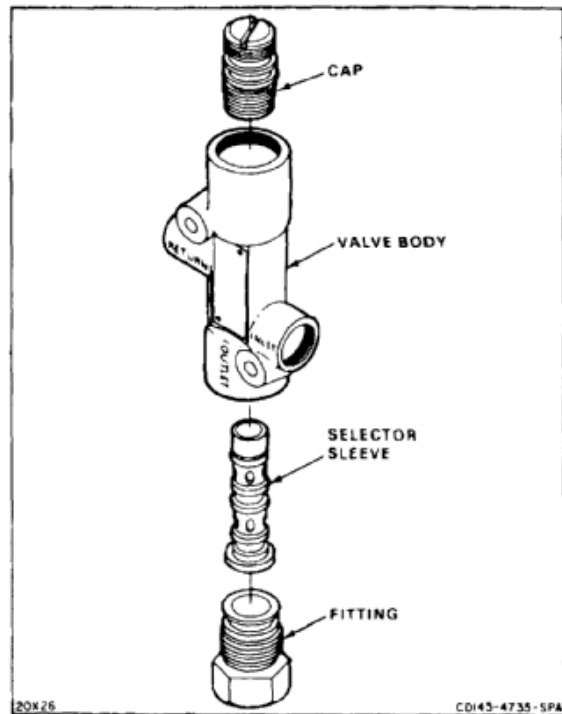

1. Install two packings (1) and three retainers (2) on selector sleeve (3).
2. Install retainer (4) and packing (5) on seat (6).
3. Install seat (6), ball (7), and plunger (8) in selector sleeve (3).

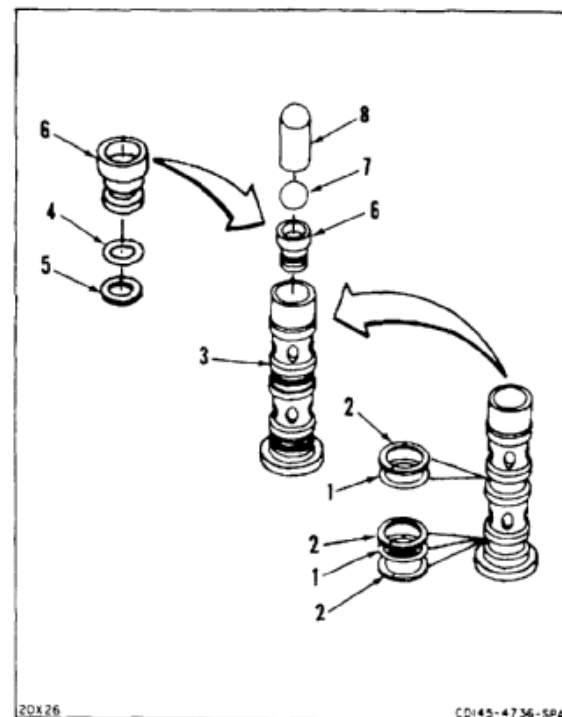

4. Install retainer (9) on selector slide (10).
5. Measure distance from end of retainer (9) to recessed end of selector slide (10). Distance shall be **1/16 inch**. If distance is not **1/16 inch**, remove retainer, rotate **180°** and install on selector slide.

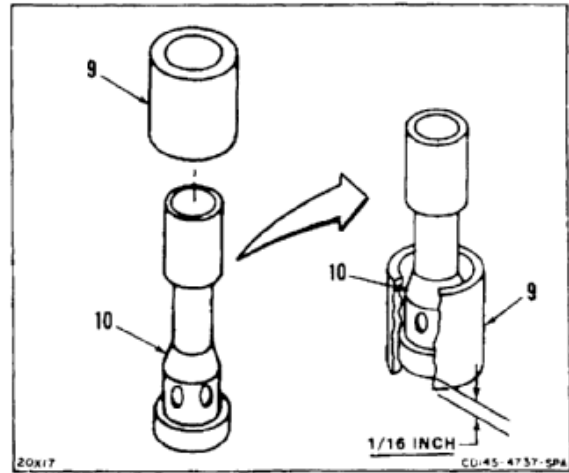

6. Install selector slide (10) in selector sleeve (3).
7. Press plunger (8) into selector sleeve (3) until top of plunger is flush with top of selector sleeve.

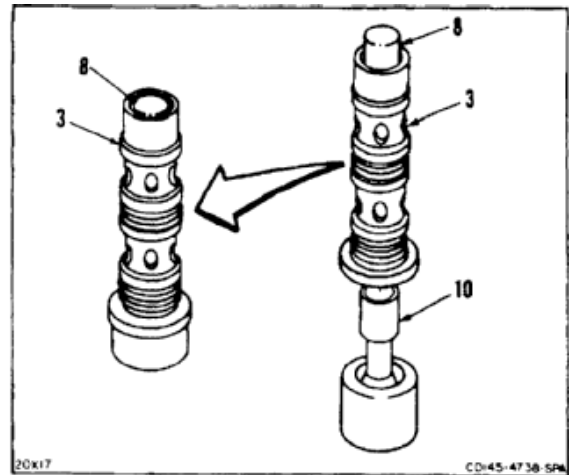

8. Install packing (11) on washer (12).
9. Install washer (12), small end first, in fitting (13).
10. Install retainer (14) and packing (15) on fitting (13).
11. Install selector sleeve (3), spring (16), and fitting (13) in OUTLET port (17) of valve body (18).

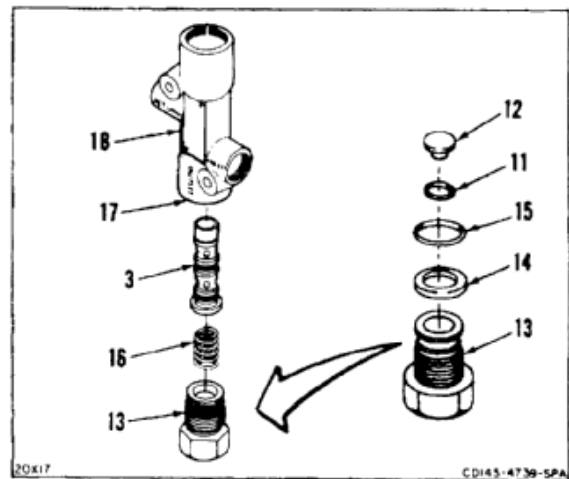

12. Install locknut (19), retainer (20), and packing (21) on cap (22).
13. Install seat (23), washer (24), spring (25), and cap (22) in valve body (18).

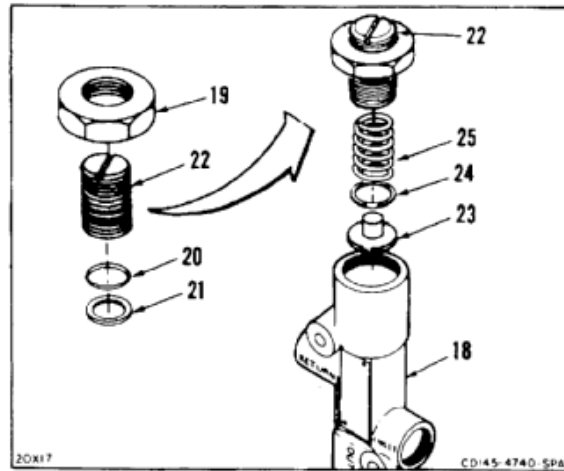

14. Position valve body (18) in soft jawed vise (19), fitting (13) up.
15. Torque fitting (13) to **250 inch-pounds**.
16. Lockwire fitting (13) to body (18). Use lockwire (E231).
17. Remove body (18) from vise (19).

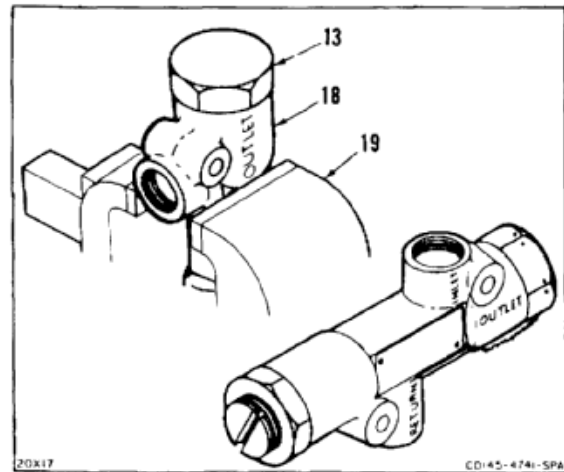
INSPECT**FOLLOW-ON MAINTENANCE:**

Test pressure reducing valve (Task 7-258).

END OF TASK

7-942

INITIAL SETUP

Applicable Configurations:

All

Tools:

- Hydraulic Repairer's Tool Kit, NSN 5180-00-323-4891
- Hydraulic Test Stand
- Hydraulic Hand Pump, 0 to 4500 psi
- Graduate Cylinder, 50 cc
- Stopwatch
- Flowmeter, 0 to 5 gpm
- Shutoff Valve (3)
- Gage, 0 to 4500 psi
- Gage, 0 to 1800 psi
- Shutoff Valve, Solenoid Operated
- Pressure Plug (2)
- Flexible Hose, 0 to 4500 psi
- Hydraulic Tube, 0 to 4500 psi
- DC Power Supply, Capable of 28 Volts
- Switch
- Torque Wrench, 100 to 750 Inch-Pounds

Materials:

- Lockwire (E231)

Personnel Required:

- Aircraft Pneudraulics Repairer
- Inspector

Equipment Condition:

- Off Helicopter Task
- Valve Installed in Crash Proof Box
- Hydraulic Test Setup No. 1 (Flexible Hose)
- Hydraulic Test Setup No. 2 (Flexible Hose)
- Hydraulic Test Setup No. 3 (Hydraulic Tube)

General Safety Instructions:

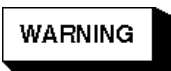

Use suitable crash box to shield personnel and equipment in case of failure during test.

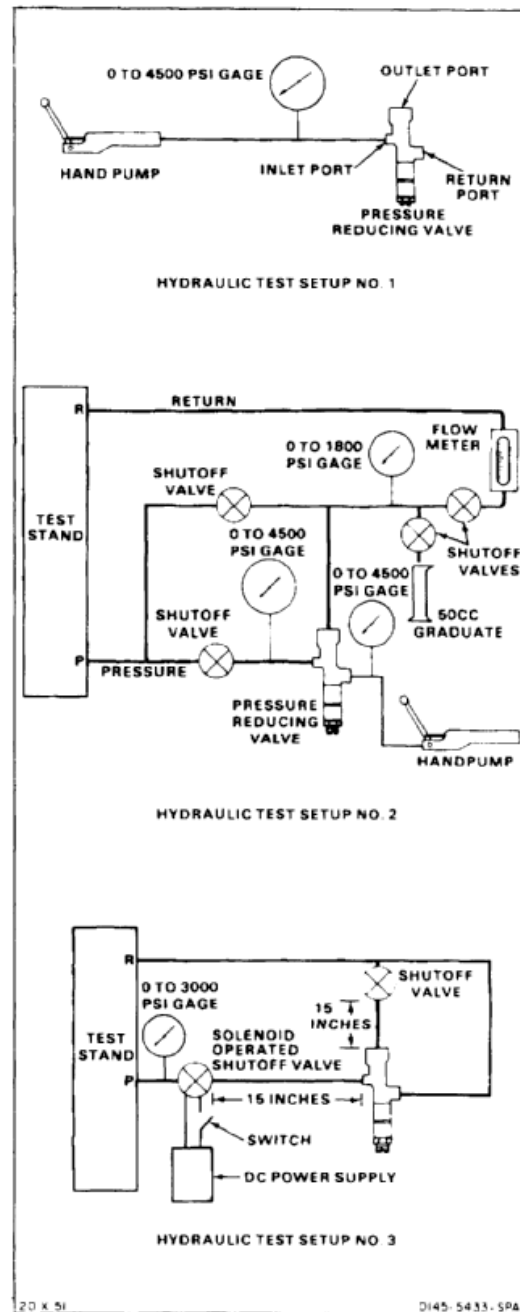

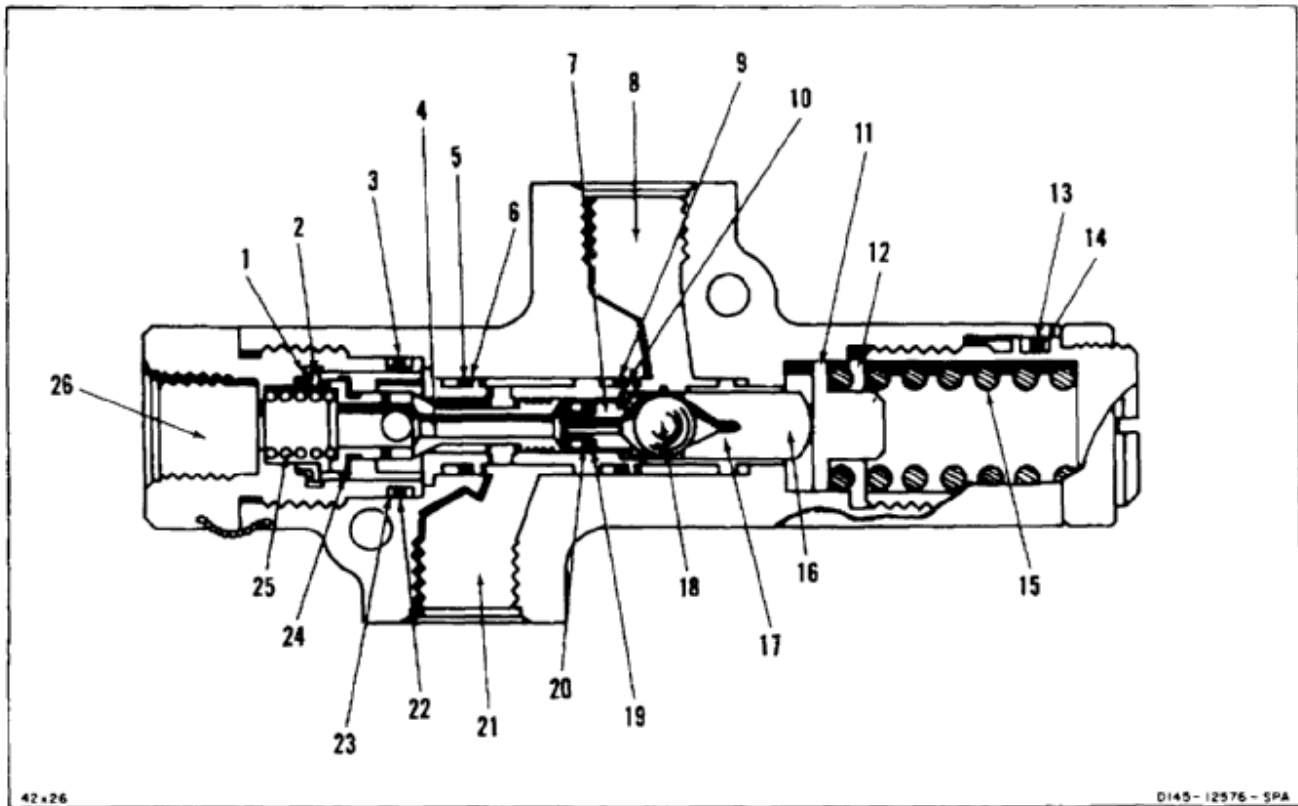

- | | |
|---------------------|-----------------------------|
| 1. Packing | 14. Backup ring |
| 2. Washer | 15. Spring |
| 3. Packing | 16. Push rod |
| 4. Reducer assembly | 17. Relief assembly |
| 5. Packing | 18. Ball |
| 6. Backup ring | 19. Packing |
| 7. Ball seat | 20. Backup ring |
| 8. Return | 21. Inlet |
| 9. Packing | 22. Packing |
| 10. Backup ring | 23. Backup ring |
| 11. Retainer | 24. Dashpot |
| 12. Shim washer | 25. Spring |
| 13. Packing | 26. Reduced pressure outlet |

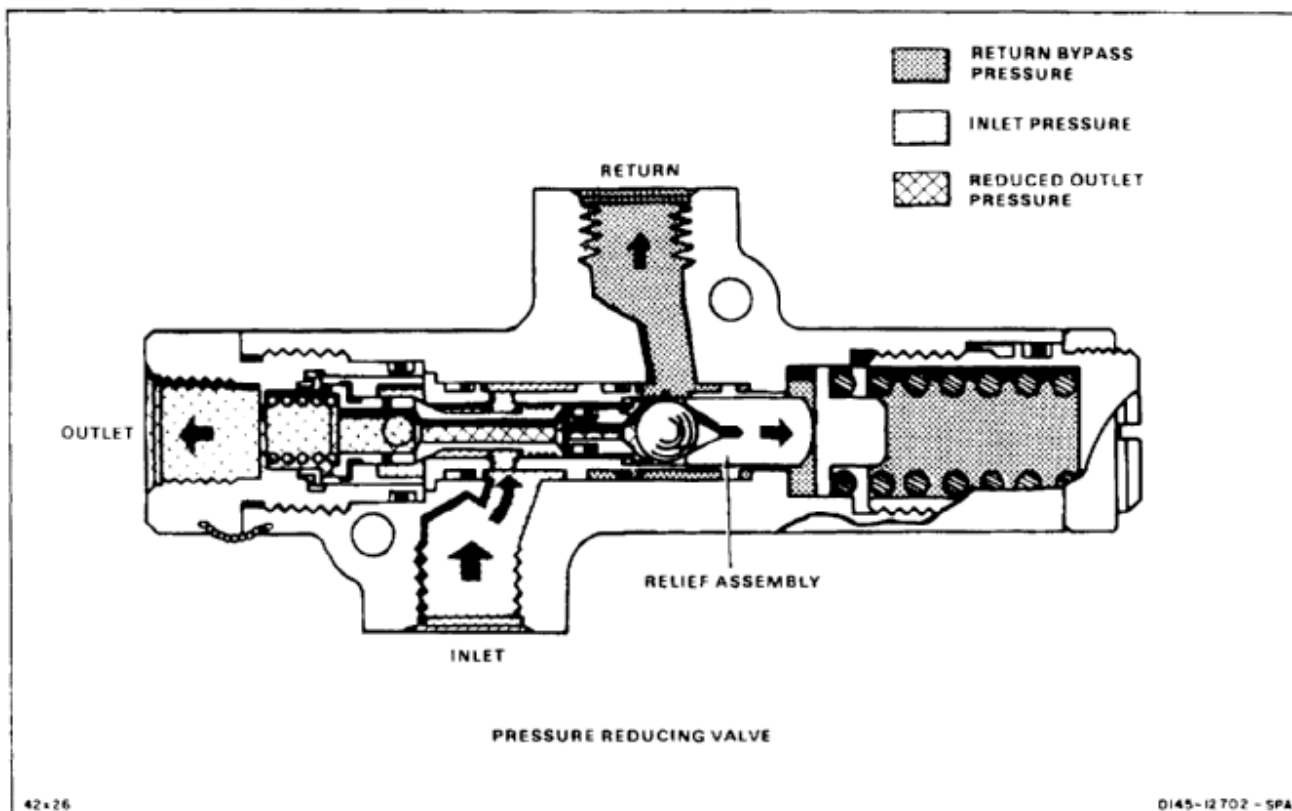

INTEGRITY PRESSURE TEST

1. Connect test setup No. 1 to INLET port (1) of valve (2).
2. Apply pressure to INLET port (1) until valve (2) is free of air.
3. Reduce pressure at INLET port (1) to **0 psi**.

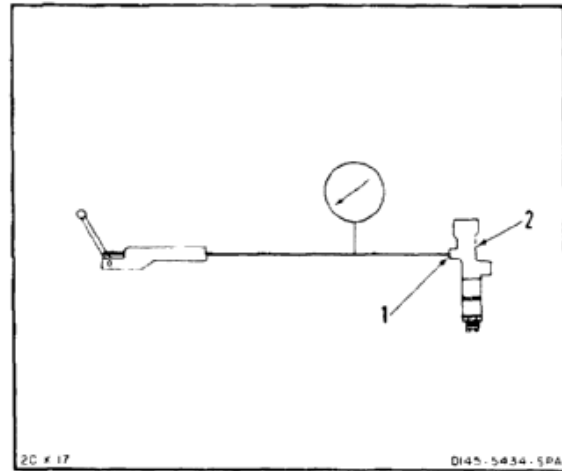

4. Install pressure plugs in OUTLET port (3) and RETURN port (4).
5. Apply **4500 psi** pressure to INLET port (1). Maintain pressure for **2 minutes**. Check valve (2). There shall be no external leaks.
6. Reduce pressure at port (1) to **0 psi**.
7. Disconnect test setup from port (1).

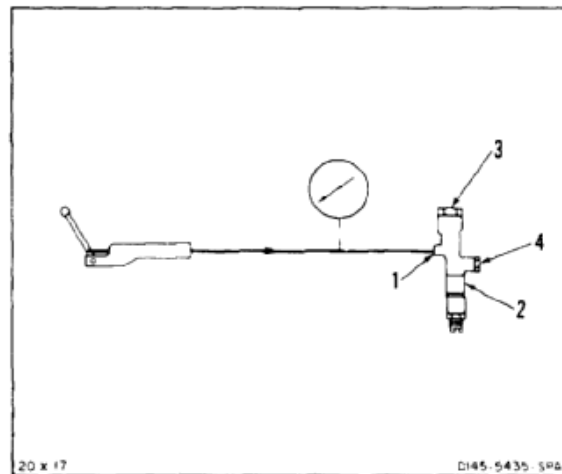

PRESSURE SETTING TEST

8. Connect hoses (5, 6, and 7) to INLET port (1), OUTLET port (3), and RETURN port (4) of valve (2).
9. Close shutoff valves (8, 9, and 10).
10. Apply **100 psi** pressure to RETURN port (4).
11. Open shutoff valve (10) and apply **3,000 psi** pressure to INLET port (1).
12. Adjust shutoff valve (11) for flow **20 cc per minute** from OUTLET port (3).
13. Check pressure gage (12). Pressure shall be **1450 psi**. If reading is not **1450 psi**, adjust end cap (13) to obtain reading.
14. Close shutoff valve (11).

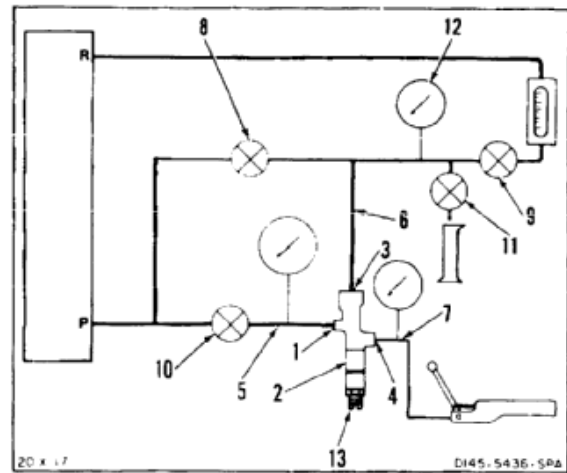
**PRESSURE REDUCING AND FLOW TEST**

15. Adjust valve (9) for flow of **3.5 gpm** on flowmeter (14).
16. Check pressure gage (12). Pressure gage shall read **1230 psi** or more. If pressure reading is not **1230 psi** or more, adjust end cap (13) to obtain reading.
17. If end cap (13) is adjusted, repeat steps 9 thru 14. All pressure readings must be obtained at one setting of end cap.
18. Reduce pressure at return port (4) to **0 psi**.
19. Close valve (10) to reduce pressure at INLET port (1) to **0 psi**.

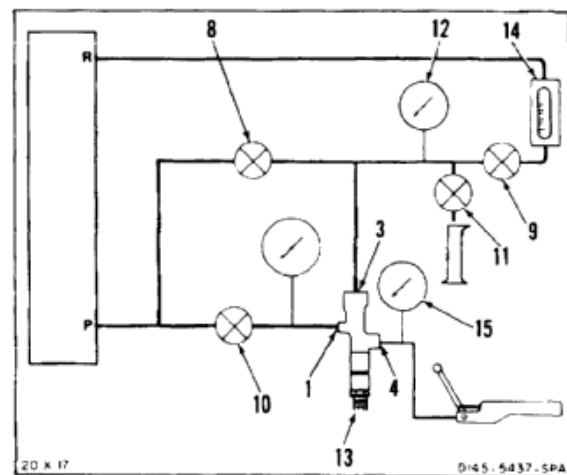
**RELIEF CRACKING PRESSURE TEST**

20. Close shutoff valves (9 and 11).
21. Open shutoff valve (8) slowly. Apply pressure to outlet port (3) until cracking flow (rise in pressure) at gage (15) is observed.

22. When pressure at gage (15) starts to rise, check pressure at gage (12). Pressure shall be less than **1630 psi**. If reading is more than **1630 psi**, adjust end cap (13) for a reading below **1630 psi**.
23. If end cap (13) is adjusted, repeat steps 9 thru 22. All pressure readings must be obtained at one setting of end cap.
24. Close shutoff valve (8) to reduce pressure at outlet port (3) to **0 psi**.

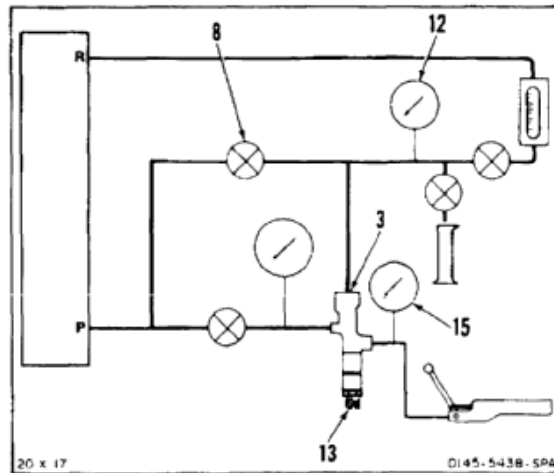

MAXIMUM REGULATED PRESSURE TEST

25. Open shutoff valve (10) and apply **3000 psi pressure** to INLET port (1).
26. Adjust shutoff valve (11) for flow of **10 cc per minute**.
27. Check pressure gage (12). Pressure gage shall read less than **1500 psi**. If reading is more than **1500 psi**, adjust end cap (13) to obtain reading.
28. If end cap (13) is adjusted, repeat steps 9 thru 28. All pressure readings must be obtained at one setting of end cap.
29. Reduce pressure at RETURN port (4) to **0 psi**.
30. Close shutoff valve (10) to reduce pressure at INLET port (1) to **0 psi**.
31. Disconnect hoses (5, 6, and 7) from ports (1, 3 and 4).

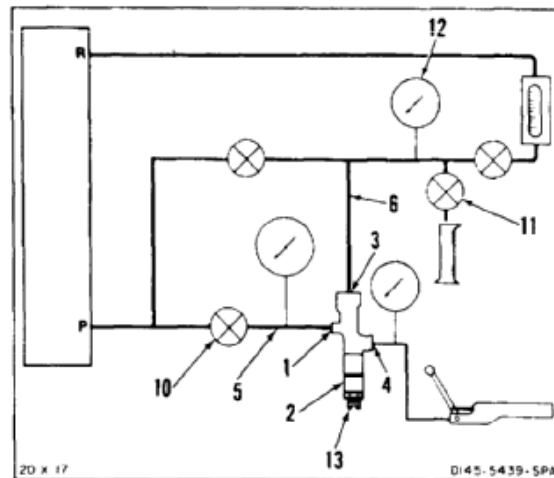

INSTABILITY TEST

32. Connect tube (16) of test setup No. 3 to INLET port (1) of valve (2).
33. Connect tube (17) to OUTLET port (3).
34. Connect tube (18) to RETURN port (4).
35. Open shutoff valve (19). Close switch (20) to open solenoid shutoff valve (21).
36. Apply pressure to INLET port (1) of valve (2). Bleed valve until valve is air free.
37. Close shutoff valve (19). Open switch (20) to close solenoid shutoff valve (21).
38. Raise pressure to solenoid shutoff valve (21) to **3,000 psi**.
39. Close and open switch (20) to actuate solenoid shutoff valve (21).
40. Check valve (2) for squeals, chattering or other signs of instability. There shall be no squeals or chattering.
41. Repeat steps 39 and 40 **10 times**.
42. Reduce pressure to solenoid shutoff valve (21) to **0 psi**.
43. Disconnect tubes (16, 17, and 18) from ports (1, 3, and 4).
44. Torque locknut (22) to **200 inch-pounds**.
45. Lockwire locknut (22) to valve (2). Use lockwire (E231).

FOLLOW-ON MAINTENANCE:

None

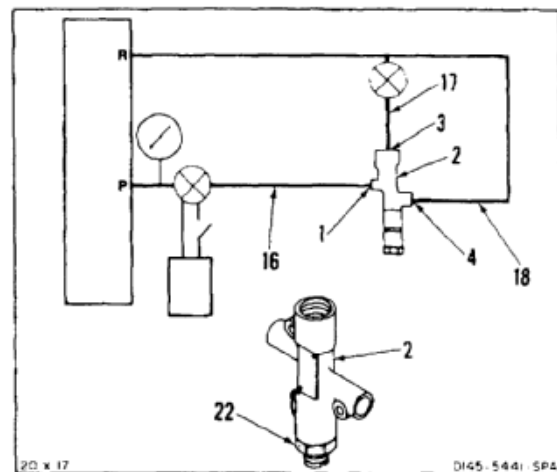
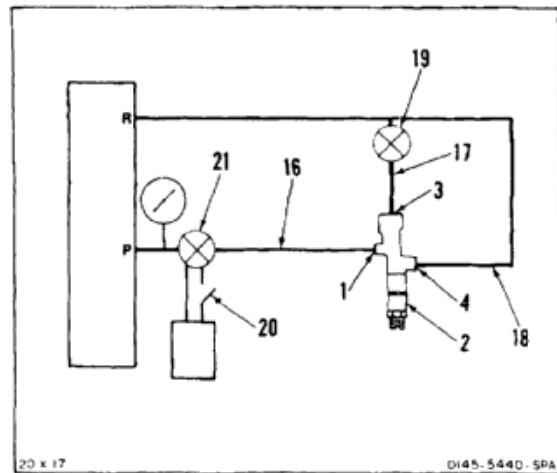

END OF TASK

INITIAL SETUP

Applicable Configurations:

All

Tools:

Aircraft Mechanic's Tool Kit, NSN 5180-00-323-4692

Materials:

None

Parts:

Preformed Packings
Washers

Personnel Required:

Medium Helicopter Repairer
Inspector

References:

TM 55-1520-240-23P

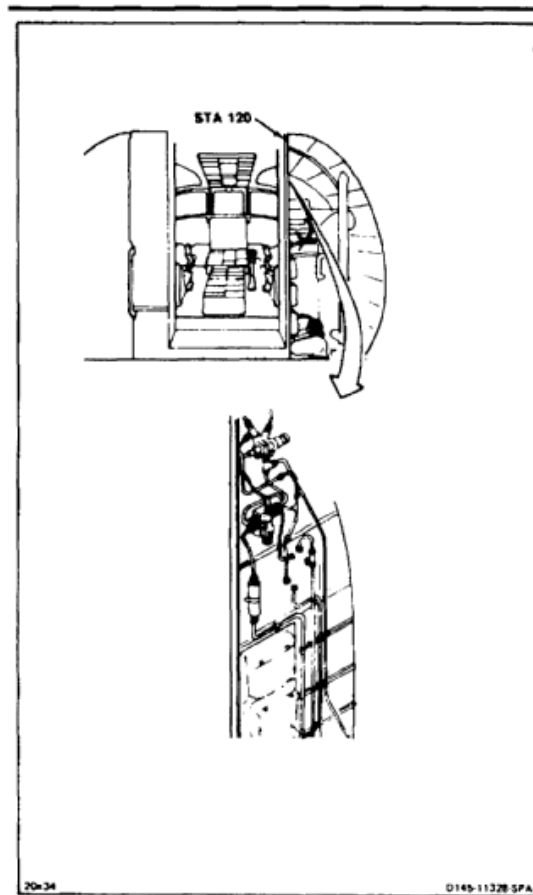

1. Connect tee (1) to OUTLET port (2) of valve (3). Do not tighten nut (4) at this time.
2. Install tee (5), packing (6), and washer (7) in INLET port (8) of valve (3). Do not tighten nut (9) at this time.
3. Install nipple (10) and packing (11) in RETURN port (12) of valve (3).

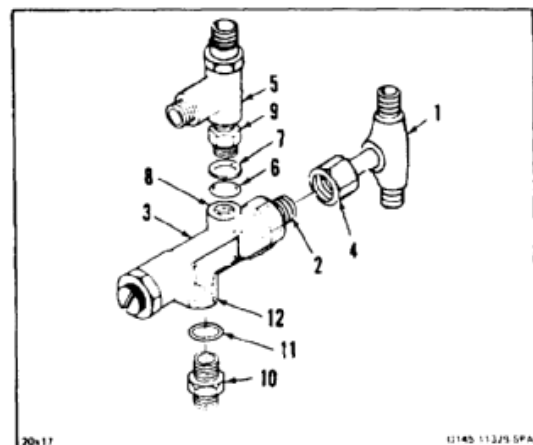

4. Position valve (3) on structure (13). Install two bolts (14) and washers (15).
5. Connect two tubes (16 and 17) to tee (1). Tighten nut (4). Remove tag from tubes.
6. Connect two tubes (18 and 19) to tee (5). Tighten nut (9). Remove tag from tubes.
7. Connect tube (20) to nipple (10). Remove tag from tube.

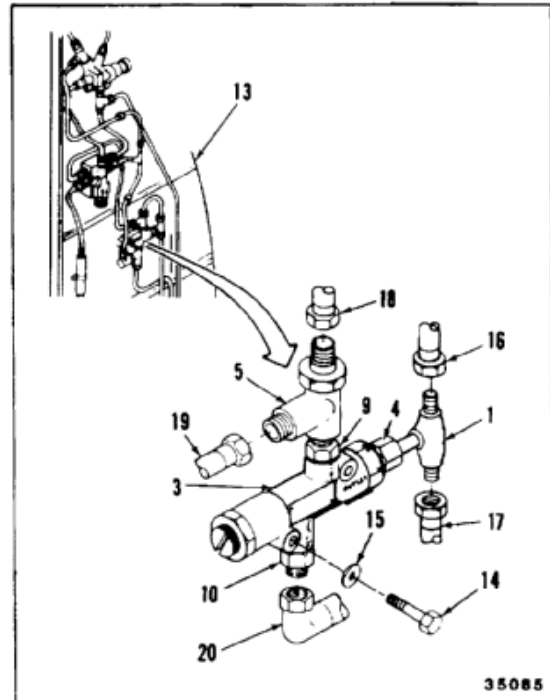
INSPECT**FOLLOW-ON MAINTENANCE:**

- Service utility hydraulic system (Task 1-59 or 1-62).
- Perform operational check of hoist (TM 55-1520-240-T).
- Install heat compartment acoustic blanket (Task 2-210).

END OF TASK

INITIAL SETUP

Applicable Configurations:

All

Tools:

Aircraft Mechanic's Tool Kit, NSN 5180-00-323-4692

Materials:

Cloths (E135)
 Paper Tags (E264)
 Gloves (E186)

Personnel Required:

Medium Helicopter Repairer (2)

Equipment Condition:

Battery Disconnected (Task 1-39)
 Electrical Power Off
 Hydraulic Power Off
 Utility Hydraulic System Depressurized (Task 7-135.1)
 Tunnel Access Doors Open (Task 2-2)
 Flight Control Rod Removed (Task 11-236)

General Safety Instructions:**WARNING**

Hydraulic fluid (E199) is toxic. It can irritate skin and cause burns. Avoid inhaling. Use only with adequate ventilation. Avoid contact with skin, eyes, or clothing. In case of contact, immediately flush skin or eyes with water for at least **15 minutes**. Get medical attention for eyes.

WARNING

Hydraulic fluid ejected under pressure can cause injury to personnel. Hydraulic fluid sprayed into the air is a fire hazard.

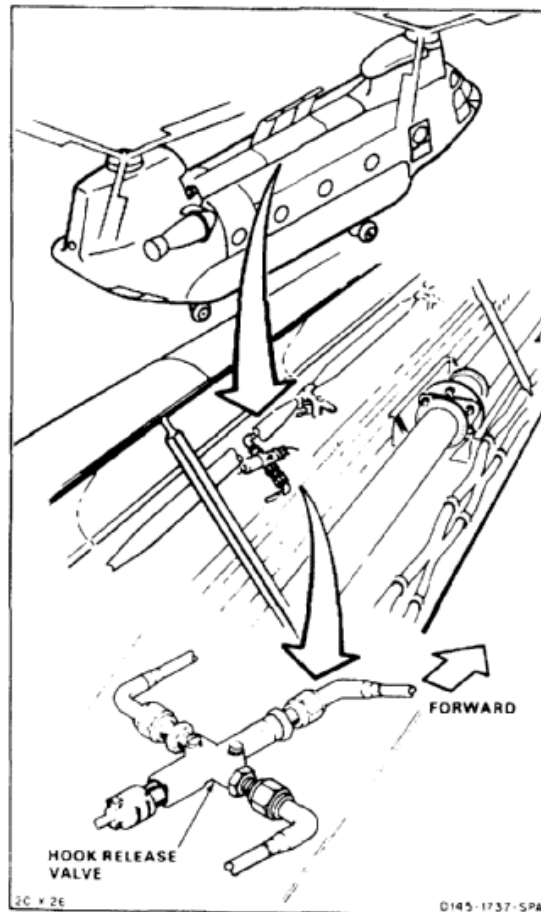

7-260 REMOVE HOOK RELEASE VALVE (Continued)

7-260

1. Remove lockwire from electrical plug (1).
2. Disconnect electrical plug (1) from valve (2).
3. Tag and disconnect three hydraulic tubes (3). Use cloths (E135) for spilled fluid. Use gloves (E186).

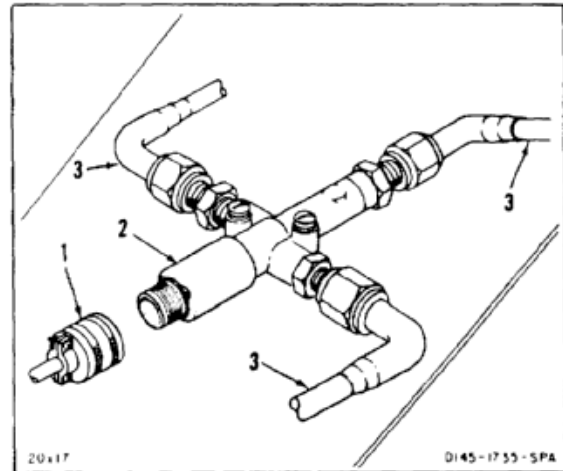

4. Remove two bolts (4) and washers (5) from valve (2). Remove valve.
5. Remove reducer (6) and packing (7).
6. Remove two nipples (8) and packings (9).

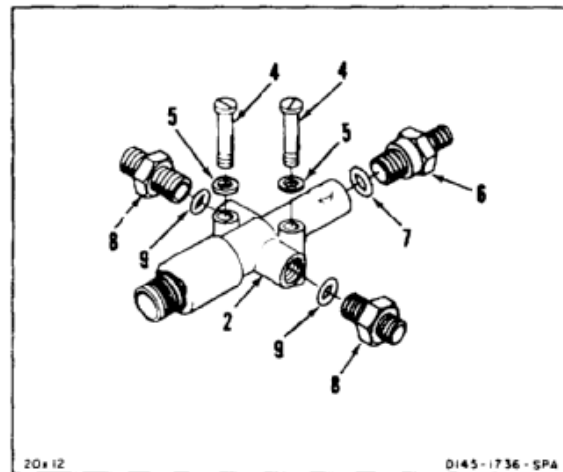
**FOLLOW-ON MAINTENANCE:**

None

END OF TASK

7-953

INITIAL SETUP

Applicable Configurations:

All

Tools:

Hydraulic Repairer's Tool Kit, NSN 5180-00-323-4891
 Fiber Rod, 1/8 Inch X 6 Inches
 Soft Jawed Vise
 Strap Wrench

Materials:

None

Personnel Required:

Aircraft Pneudraulics Repairer

Equipment Condition:

Off Helicopter Task

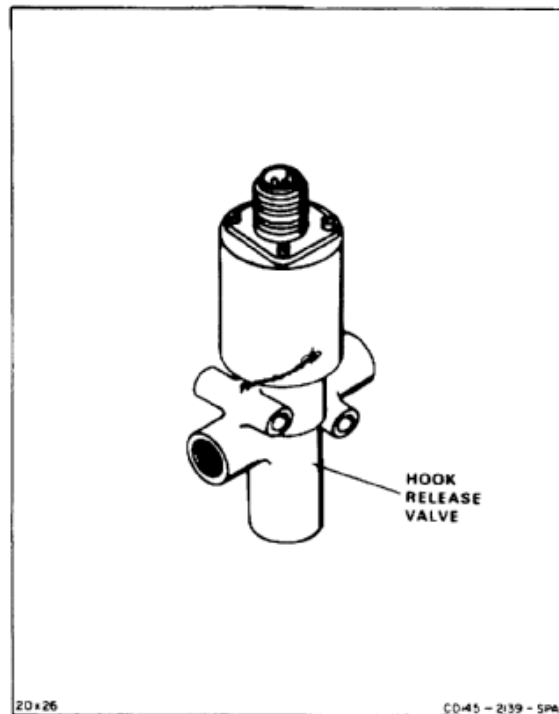

1. Position body (1) with solenoid (2) up in vise (3).
2. Remove lockwire from solenoid (2). Remove solenoid (2) from body (1). Use strap wrench.
3. Remove retainer (4) and packing (5) from solenoid (2).
4. Remove body (1) from vise (3).

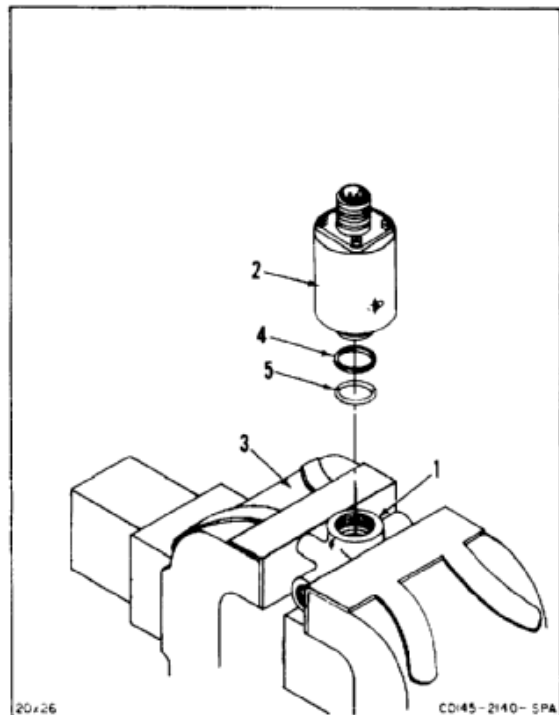

5. Insert rod (6) into port (7) of body (1).
6. Remove sleeve (8), poppet (9), spacer (10), seat (11), and spring (12) from body (1).
7. Remove packings (13 and 14) from sleeve (8).
8. Remove packing (15) from seat (11).

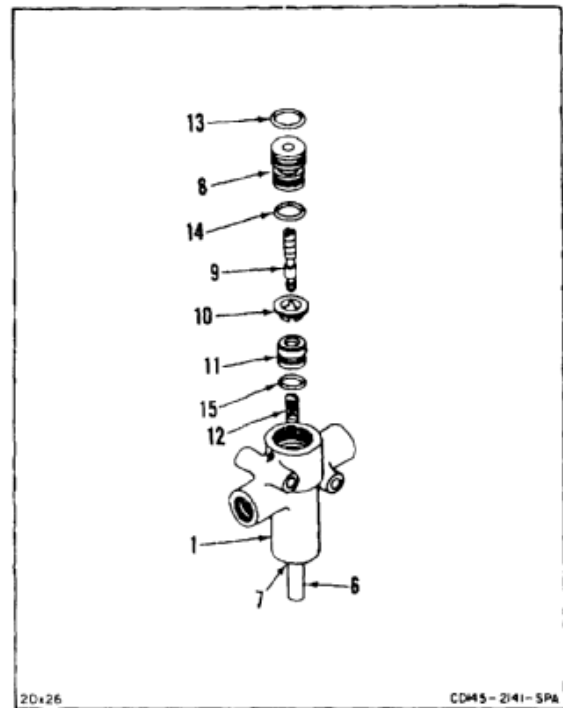
**FOLLOW-ON MAINTENANCE:**

None

END OF TASK

INITIAL SETUP

Applicable Configurations:

All

Tools:

Technical Inspection Tool Kit, NSN 5180-00-323-5114
Hole Gage, 0.200 to 0.300 Inch
Outside Micrometer, 0 to 1 Inch
Spring Compression Tester

Materials:

None

Personnel Required:

Inspector

Equipment Condition:

Off Helicopter Task
Hook Release Valve Disassembled (Task 7-261)

References:

Task 7-1.1

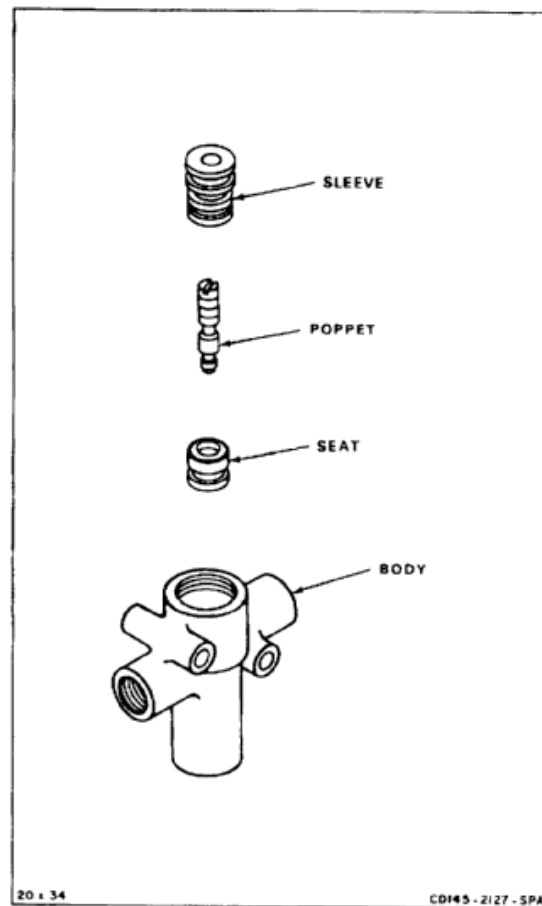

NOTE

General inspection criteria (Task 7-1.1) for obvious damage applies unless otherwise stated.

Inspection steps cover parts that are subject to wear.

1. Inspect outside diameter of two lands (1) on seat (2). There shall be no scratches or scoring.
2. Measure outside diameter of two lands (1) on seat (2). Diameter shall not be less than **0.499 inch**.
3. Inspect bores (3 and 4) in valve body (5). There shall be no nicks or scratches.
4. Measure diameter of small bore (3). Diameter shall not be less than **0.500 inch**.
5. Measure diameter of large bore (4). Diameter shall not be less than **0.625 inch**.
6. Inspect solenoid (5). There shall be no damaged thread or pin connections.

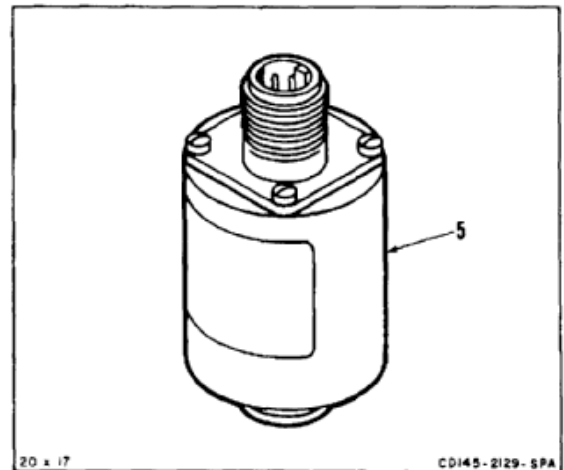
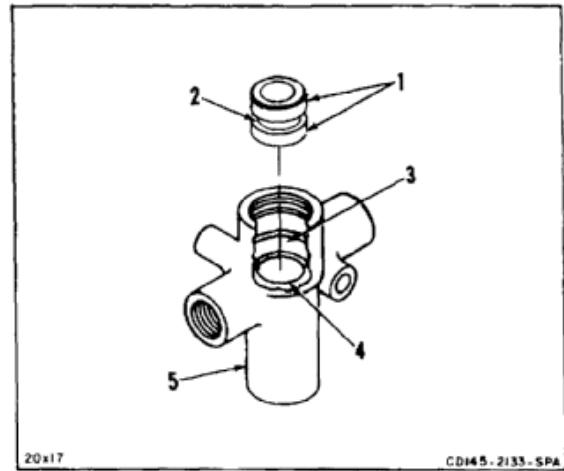

7. Measure inside diameter of sleeve (6). Diameter shall not be more than **0.219 inch**.
8. Measure outside diameter of four lands (7) of sleeve (6). Diameter shall not be less than **0.624 inch**.

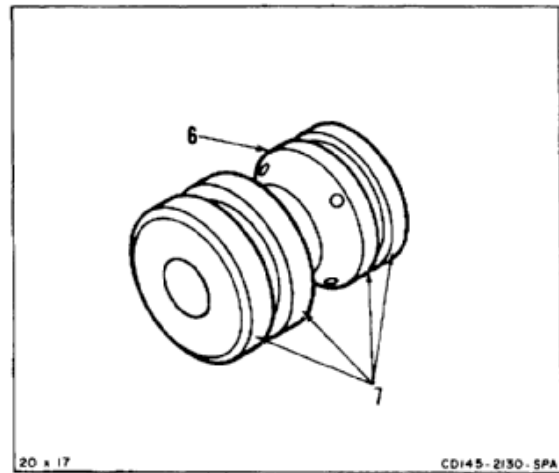

9. Measure outside diameter of upper part (8) of popper (9). Diameter shall not be less than **0.218 inch**.

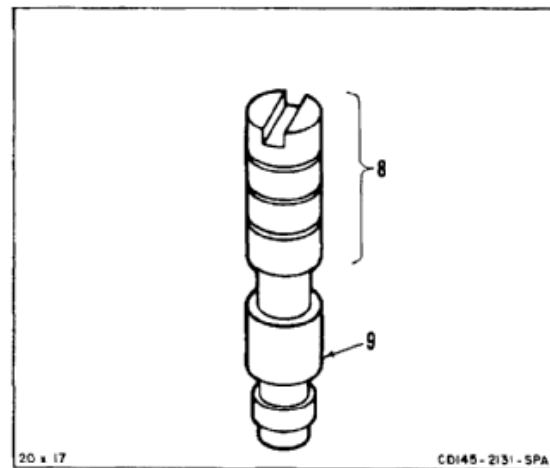

10. Install spring (10) in spring compression tester (11).
11. Compress spring (10) to **0.312 inch**. Force needed to compress spring shall be **5.4 to 6.6 pounds**.

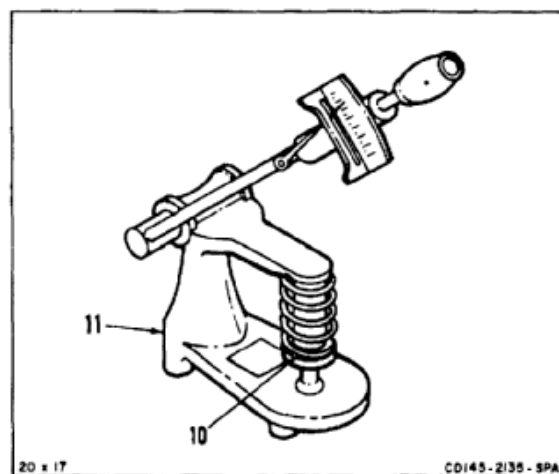
**FOLLOW-ON MAINTENANCE:**

None

END OF TASK

7-958

7-263 ASSEMBLE HOOK RELEASE VALVE (AVIM)

7-263

INITIAL SETUP**Applicable Configurations:**

All

Tools:

Hydraulic Repairer's Tool Kit, NSN 5180-00-323-4891
 Soft Jawed Vise
 Torque Wrench, 30 to 150 Inch-Pounds
 Strap Wrench

Materials:

Lockwire (E231)

Parts:

Preformed Packings
 Retainers

Personnel Required:

Aircraft Pneudraulics Repairer
 Inspector

References:

TM 55-1520-240-23P

1. Position spring (1) in valve body (2).
2. Install packing (3) on seat (4).
3. Install seat (4), spacer (5), and poppet (6) in body (2). Pilot end of poppet shall engage in spring (1).
4. Install two packings (7) on sleeve (8).
5. Install sleeve (8) in body (2).

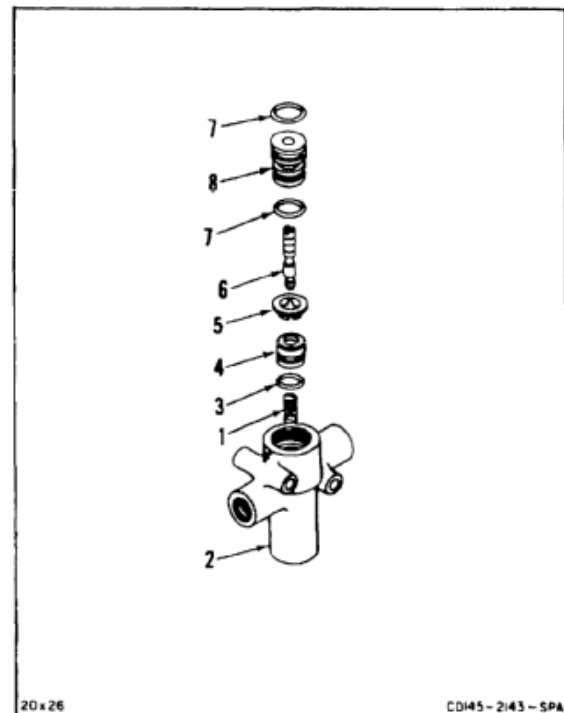

6. Position body (2) with solenoid port (9) UP in vise (10).
7. Install retainer (11), and packing (12), on solenoid (13).
8. Install solenoid (13) in body (2). Torque solenoid to **50 inch-pounds**. Use strap wrench.
9. Remove body (2) from vise (10).

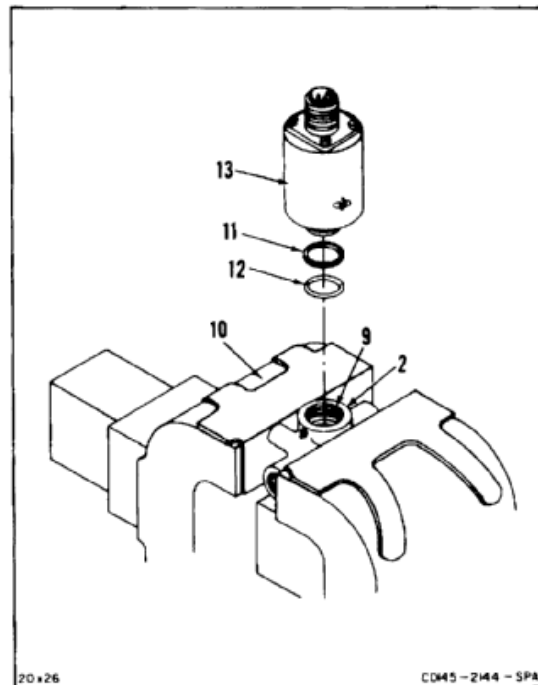

10. Lockwire solenoid (13) to valve body (2). Use lockwire (E231).

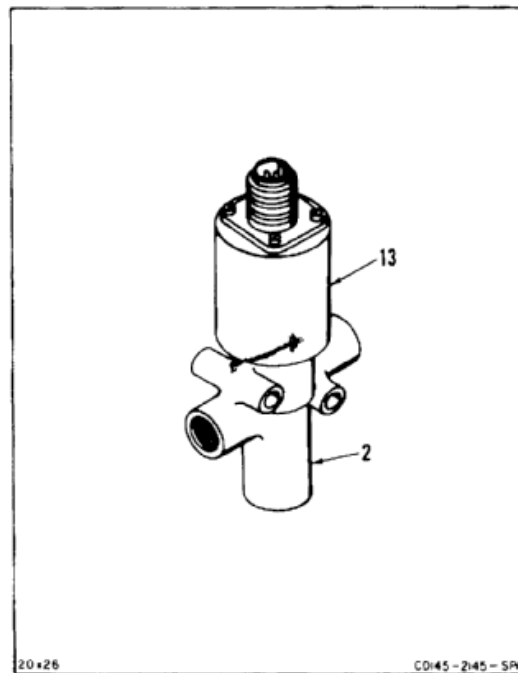
**FOLLOW-ON MAINTENANCE:**

Test hook release valve (Task 7-264).

END OF TASK

7-960

INITIAL SETUP

Applicable Configurations:

All

Tools:

Hydraulic Repairer's Tool Kit, NSN 5180-00-323-4891
 Hydraulic Test Stand
 DC Power Supply, 0 to 28 Volts
 Gages, 0 to 3,000 psi (2)
 Ammeter
 Graduate Cylinder, 0 to 50 cc
 Stop Watch

Materials:

None

Personnel Required:

Aircraft Pneudraulics Repairer
 Aircraft Electrician
 Inspector

Equipment Condition:

Off Helicopter Task
 Hydraulic Test Setup
 Electrical Test Setup
 Valve Installed in Crash Box

General Safety Instructions:**WARNING**

Use suitable crash box to shield personnel and equipment in case of failure during test.

WARNING

Hydraulic fluid (E199) is toxic. It can irritate skin and cause burns. Avoid inhaling. Use only with adequate ventilation. Avoid contact with skin, eyes, or clothing. In case of contact, immediately flush skin or eyes with water for at least **15 minutes**. Get medical attention for eyes.

WARNING

Hydraulic fluid ejected under pressure can cause injury to personnel. Hydraulic fluid sprayed into the air is a fire hazard.

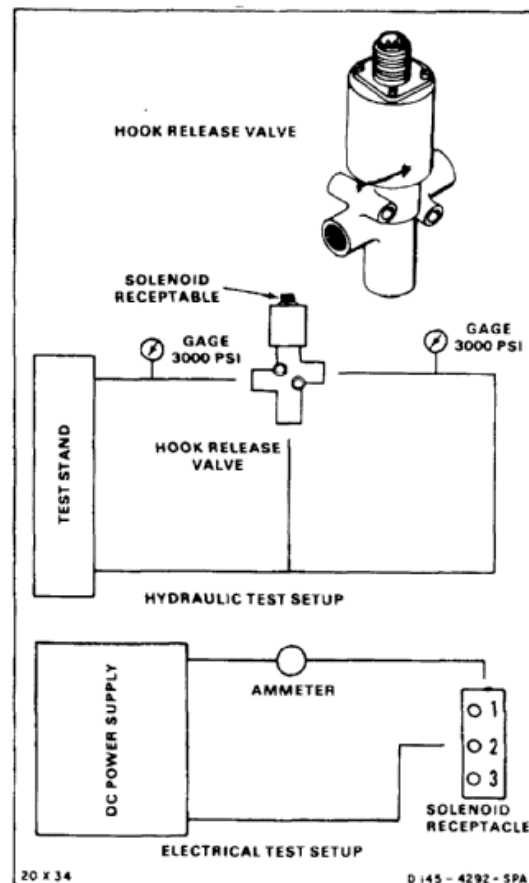

1. Connect pressure hose (1) to port (2) of hook release valve (3).
2. Connect return hose (4) to port (5) of valve (3).
3. Connect return hose (6) to port (7) of valve (3).
4. Connect dc power supply (8) to receptacle (9).

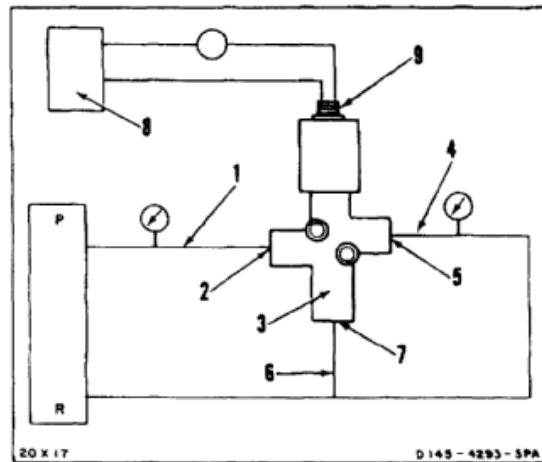

5. Adjust dc power supply (8) to **28 volts**. Maintain voltage for **3 minutes**.
6. Check current drain with ammeter (10). Current drain shall be no more than **1.4 amperes**.

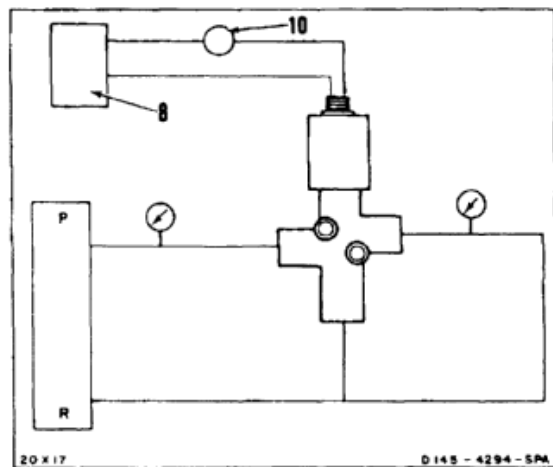

7. Reduce voltage at receptacle (9) to **0 volt**.
8. Adjust dc power supply (8) to **24 volts**.
9. Apply **3000 psi** pressure at **3 gpm** flow to port (2).
10. Check pressure reading at gage (11). Pressure reading at gage shall be **3000 psi**.

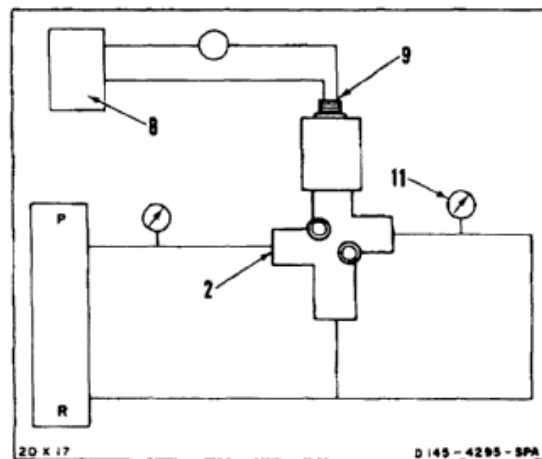

NOTE

Valve is cycled by turning dc power supply off and on one time.

11. Cycle valve (3) **5 times**.
12. Check valve (3) for external leaks. There shall be no external leaks.
13. Reduce pressure at port (2) to **0 psi**.
14. Reduce voltage at receptacle (9) to **0 volt**.

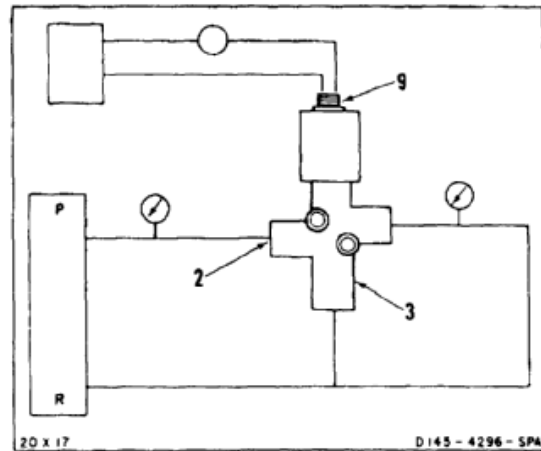

15. Disconnect hoses (4 and 6) from valve (3).
16. Install pressure cap (12) on port (7).
17. Position graduate cylinder (13) under port (5).
18. Apply **3,000 psi** pressure to port (2). Maintain pressure for **3 minutes**.
19. After **3 minutes**, check port (5) for leaks. Leaks at port (5) shall not exceed **5 cc per minute**.
20. Reduce pressure at port (2) to **0 psi**.
21. Allow valve (3) to cool for **5 minutes**.

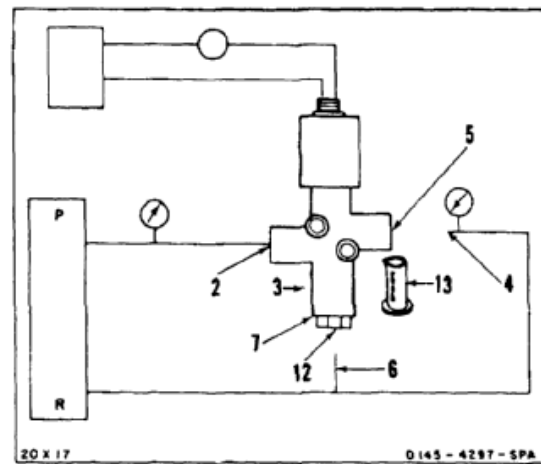

22. Remove cap (12) from port (7).
23. Install cap (12) on port (5).
24. Position graduate cylinder (13) under port (7).
25. Adjust dc power supply (8) to **22 volts**.
26. Apply **3000 psi** pressure to port (2). Maintain pressure for **3 minutes**.
27. After **3 minutes**, check port (7) for leaks. Leaks at port shall not exceed **5 cc per minute**.
28. Reduce pressure at port (2) to **0 psi**.
29. Reduce voltage at receptacle (9) to **0 volt**.

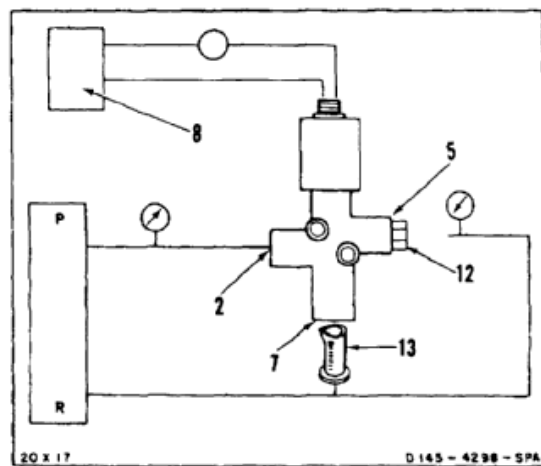

30. Disconnect hose (1) from port (2).
31. Disconnect dc power supply (8) from receptacle (9).
32. Remove cap (12) from port (5).

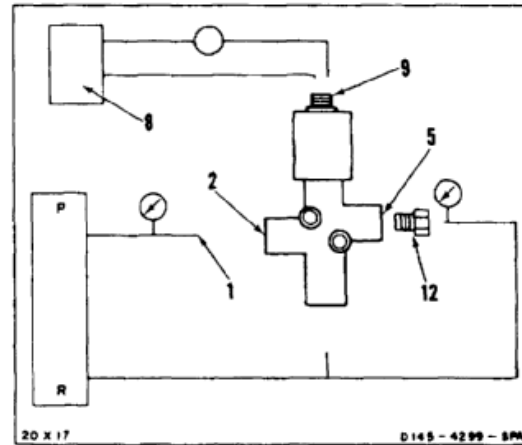
**FOLLOW-ON MAINTENANCE:**

None

END OF TASK

7-964

INITIAL SETUP

Applicable Configurations:

All

Tools:

Aircraft Mechanic's Tool Kit, NSN 51 80-00-323-4692

Materials:

Lockwire (E231)

Parts:

Preformed Packings

Personnel Required:

Medium Helicopter Repairer (2)
Inspector

References:

TM 55-1520-240-23P

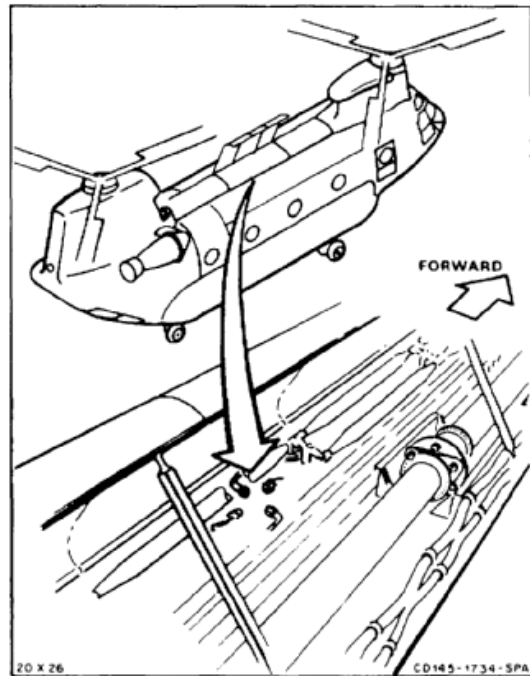

1. Install two packings (1) and nipples (2) in side ports (3).
2. Install packing (4) and reducer (5) in end port (6).

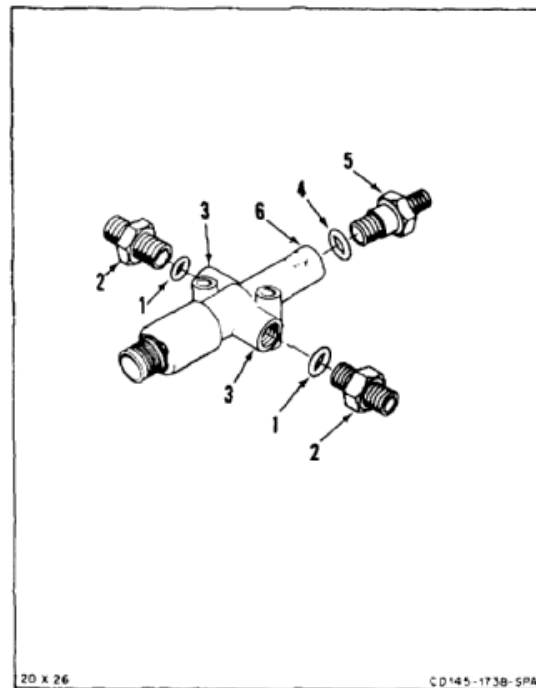

3. Position valve (7) on tunnel floor (8) as shown.
4. Install two washers (9) and bolts (10).

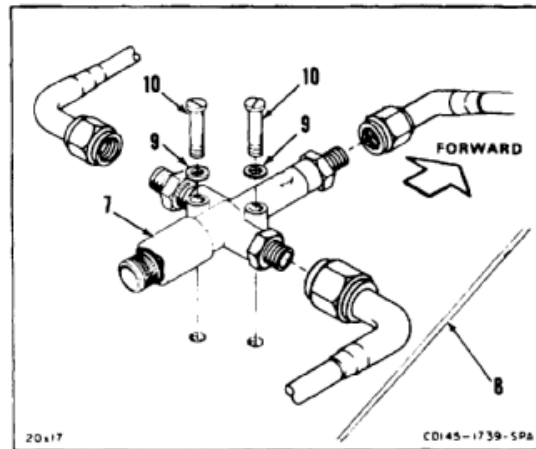

5. Connect three hydraulic tubes (11). Remove tags.
6. Connect electrical plug (12).
7. Lockwire plug (12) to valve (7). Use lockwire (E231).

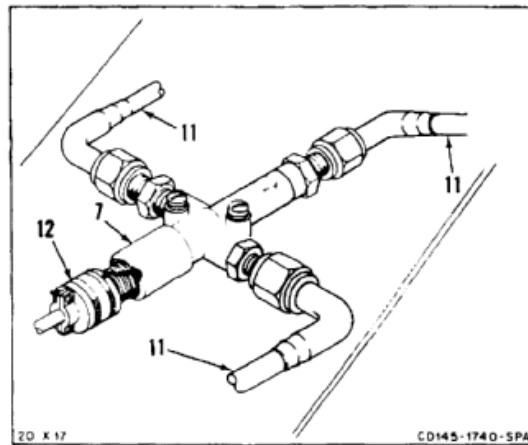
INSPECT**FOLLOW-ON MAINTENANCE:**

- Bleed utility hydraulic system (Task 7-337).
- Check operation of hook release valve (TM 55-1520-240-T).
- Install flight control rod (Task 11-237).
- Close tunnel access doors (Task 2-2).

END OF TASK

INITIAL SETUP

Applicable Configurations:

All

Tools:

Aircraft Mechanic's Tool Kit, NSN 51 80-00-323-4692

Materials:

- Cloths (E120)
- Paper Tags (E264)
- Gloves (E186)

Personnel Required:

Medium Helicopter Repairer

Equipment Condition:

- Battery Disconnected (Task 1-39)
- Electrical Power Off
- Hydraulic Power Off
- Cargo Ramp Down (TM 55-1520-240-T)
- Utility Hydraulic System Depressurized (Task 7-135.1)

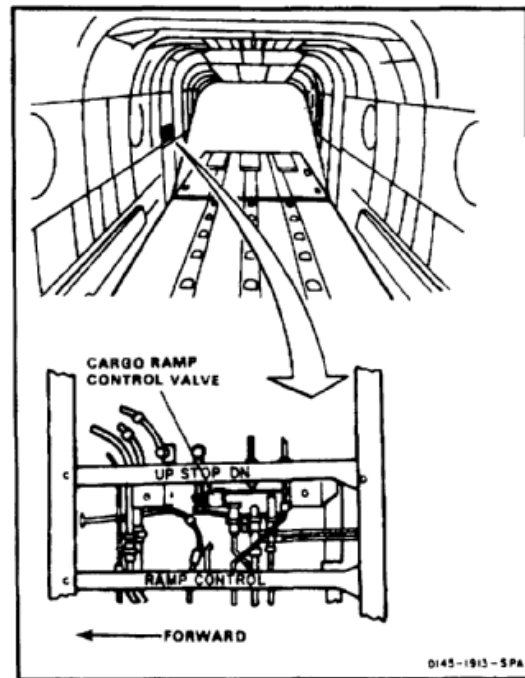

NOTE

Ramp control valves on aircraft without **65** are serviceable as described in Task 7-267. Ramp control valves on aircraft with **65**, shall be repaired per Task 7-267.1.

Tubing shown in illustration is same for both valves with or without **65**. For clarity, tubing is not shown under valve with **65**.

1. On valve with **65**, remove connector (5.1) from ramp control valve
- 1.1. Tag and disconnect seven hydraulic tubes (1). Use cloths (E120) under valve (2) and around tubes for spilled fluid. Use gloves (E186).
2. Remove lockwire, three bolts (3), washers (4), and spacers (5). Remove valve (2).

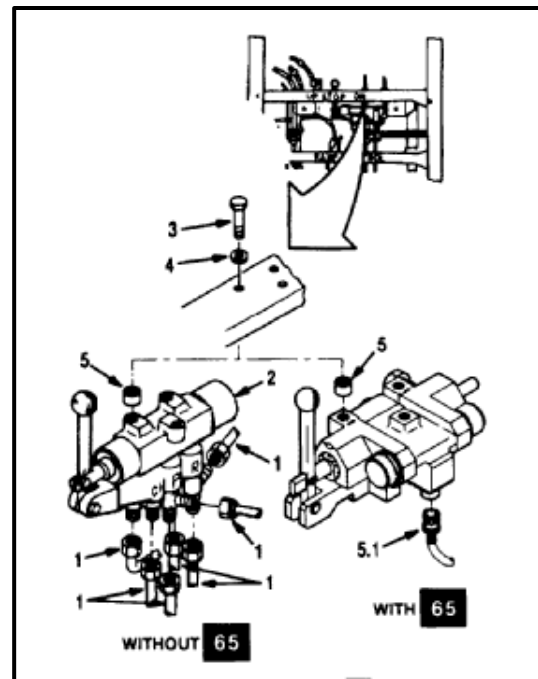

NOTE

Valve without **65** shown in view A, is typical to reflect basic installation of hardware.

3. Remove three nipples (6) and packings (7) from ports C1, G2, and C3.

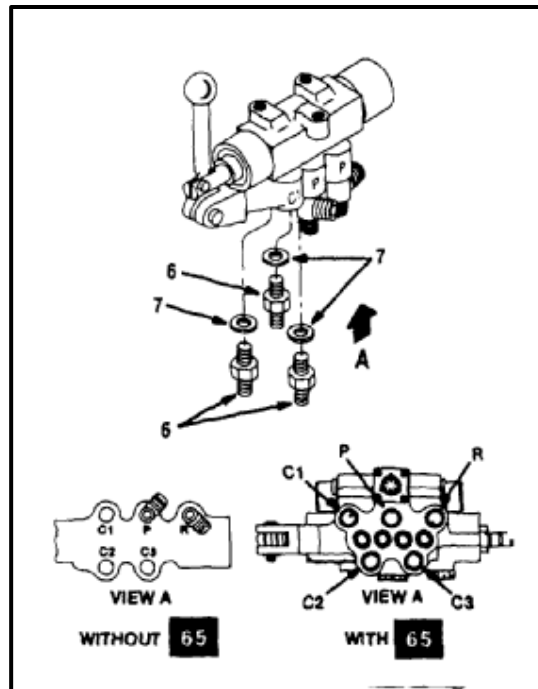

NOTE

Valve shown is without **65**. The valve is typical and reflects common locations of pressure (P) and return (R) ports and related components.

4. Loosen two nuts (8). Remove two tees (9), washers (10), and packings (11) from ports P and R.

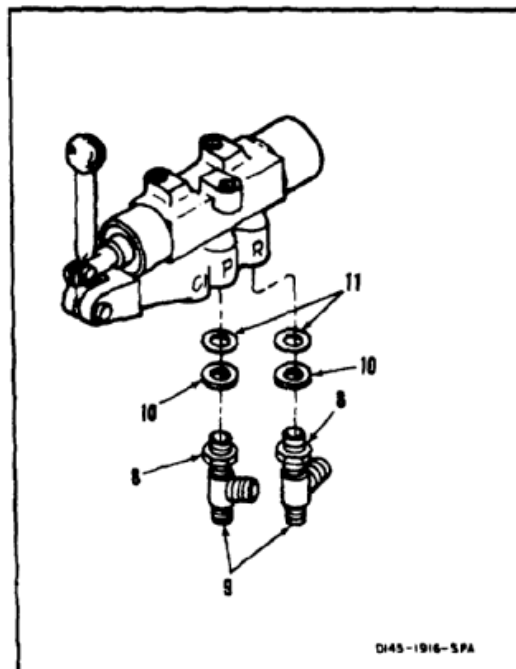

FOLLOW-ON MAINTENANCE:

None

END OF TASK

INITIAL SETUP

Applicable Configurations:

Aircraft Without **65**

Tools:

- Hydraulic Repairer's Tool Kit, NSN 5180-00-323-4891
- Spanner Wrench Set
- Spanner (APP E-3)
- Soft Jawed Vise
- Wood Dowel, 5/16 Inch X 6 Inches
- Technical Inspection Tool Kit, NSN 5180-00-323-5114

Materials:

Paper Tag (E264)

Personnel Required:

- Aircraft Pneudraulics Repairer
- Inspector

References:

- Task 7-1.1
- Appendix E

Equipment Condition:

Off Helicopter Task

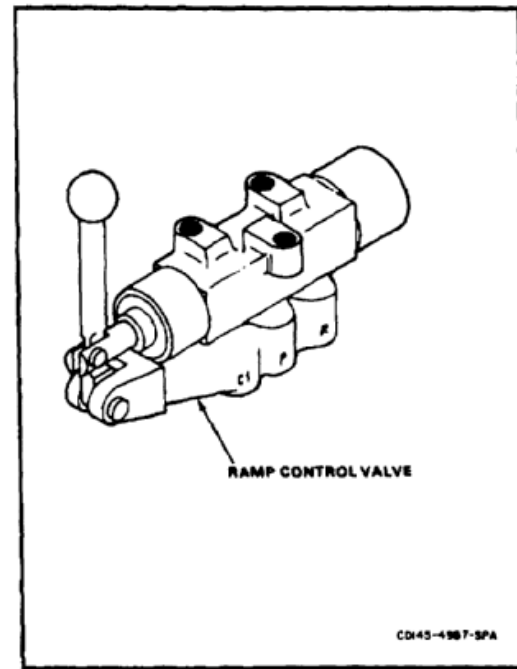

NOTE

General inspection criteria (Task 7-1.1) for obvious damage applies unless otherwise stated.

Inspection steps cover parts that are subject to wear.

1. Position handle (1) **90°** to clevis (2).
2. Remove lockwire from seat plug (3).
3. Remove plug (3), ball (4), seat (5), and spring (6) from valve body (7).
4. Remove pin (8), from plug (3).
5. Remove two retainers (9) and packing (10) from plug (3).
6. Remove two retainers (11) and packing (12) from plug (3).
- 6.1. Inspect ball (4). There shall be no nicks or scratches.
- 6.2. Inspect seat (5). There shall be no nicks or burrs.
- 6.3. Inspect seat (12.1) of plug (3). There shall be no nicks or burrs.

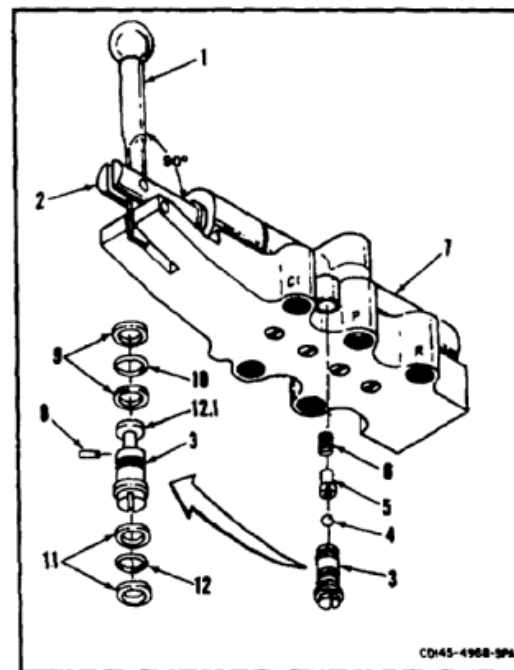

7. Remove cotter pin (13) and washer (14) from pin (15).
8. Remove pin (15) and washer (16) from handle (1).
9. Remove cotter pin (17) and washer (18) from pin (19).
10. Remove pin (19) and washer (20) from handle (1).

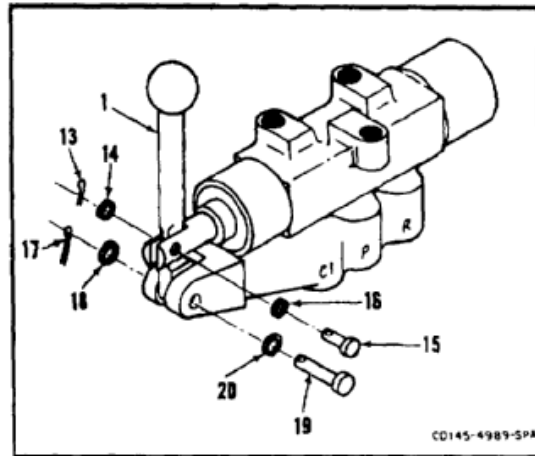

NOTE

Detent ball will fall from valve body when handle is removed.

11. Remove handle (1), detent bail (21), and spring (22) from body (7).
12. Turn knob (23) counterclockwise and remove from handle (1).

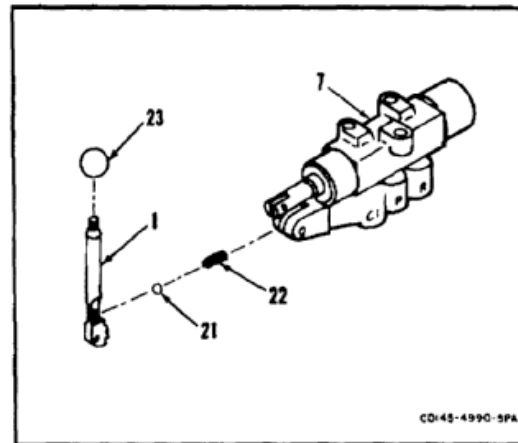

13. Turn valve cap (24) counterclockwise until thread disengages.
14. Push clevis (2) into body (7), while pulling on valve cap (24). Remove valve cap, with attached parts, from body.

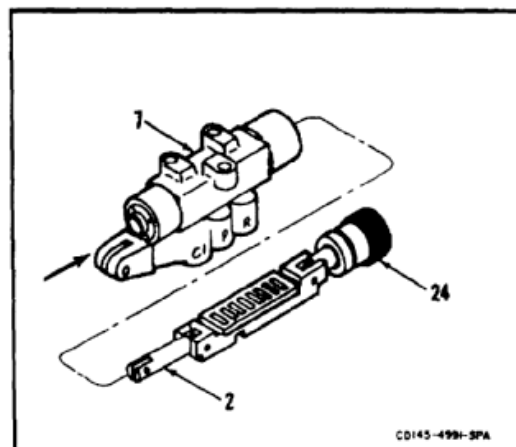

7-267 DISASSEMBLE AND INSPECT 114HS111 RAMP CONTROL VALVE (AVIM) (Continued)

7-267

15. Remove nine rollers (25) and space plate (26) from plate (27).
16. Remove valve cap (24) from guide shaft (28).
17. Remove packing (29) and retainer (30) from valve cap (24).
- 17.1. Inspect bore of valve cap (24). Bore shall have no nicks or scratches.
- 17.2. Insert guide shaft (28) in bore of valve cap (24). Shaft shall slide easily in bore, with no binding.

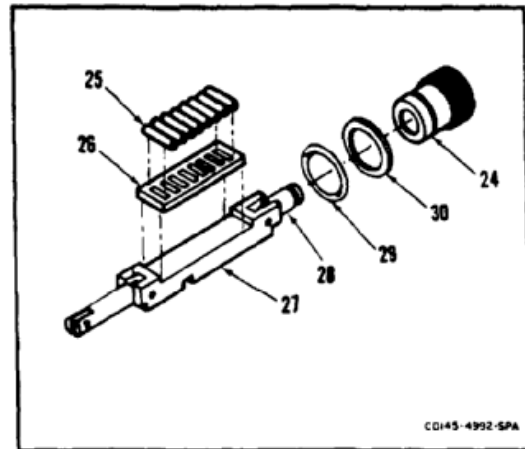

18. Remove pin (31) and guide shaft (28) from plate (27).
19. Remove packing (32) and two retainers (33) from guide shaft (28).
- 19.1. Inspect guide shaft (28). Shaft shall have no nicks or scratches.
- 19.2. Insert guide shaft (28) in bore of valve cap (24). Shaft shall slide easily in bore, with no binding.
20. Remove pin (34) and clevis (2) from plate (27).
- 20.1. Inspect bottom surface (34.1) of plate (27). There shall be no nicks or scratches.
- 20.2. Inspect clevis (2). Shaded area of clevis shall have no nicks or scratches.

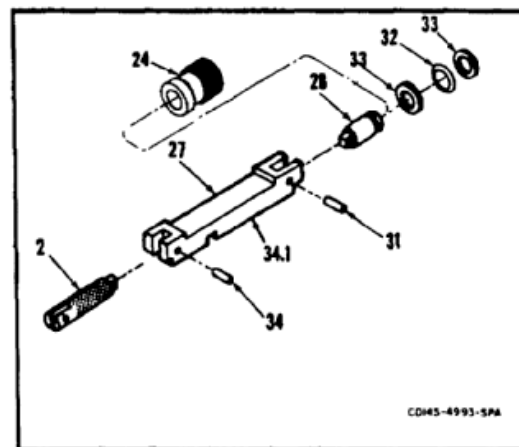

21. Remove bearing plate (35) from body (7).
22. Remove bearing and packing (36) from body (7). Use spanner (37) (APP E-3).
23. Remove two packings (38 and 39) and two retainers (40 and 41) from bearing and packing (36).

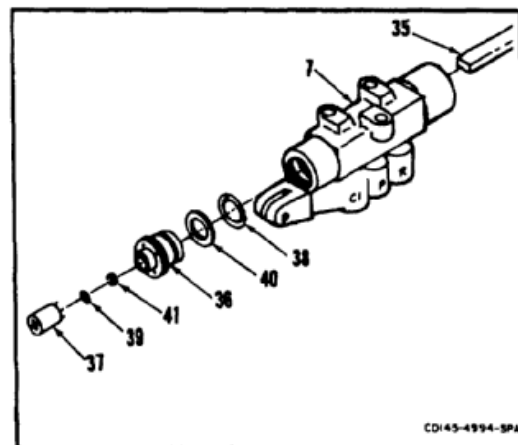

24. Position body (7) on work bench with caps (42) up.
25. Remove four valve caps (42) and four springs (43) from body (7).
26. Remove packing (44) and retainer (45) from each valve cap (42).

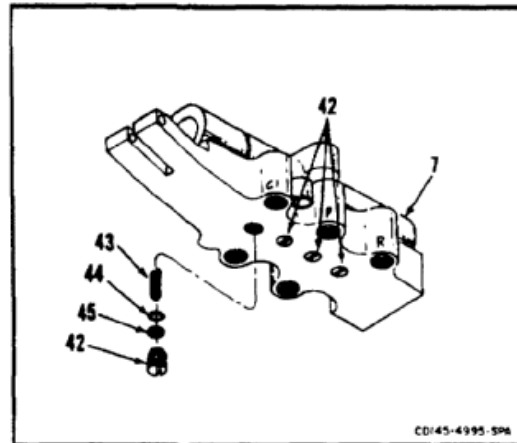

27. Insert dowel (46) into port (47), port (48), port (49), and port (50), in turn, and push poppets (51) from body (7).
28. Remove four poppets (51) from body (7).
29. Remove packing (52) and retainer (53) from each poppet (51).
30. Inspect face (54) of each poppet (51). Face shall have no nicks or scratches.

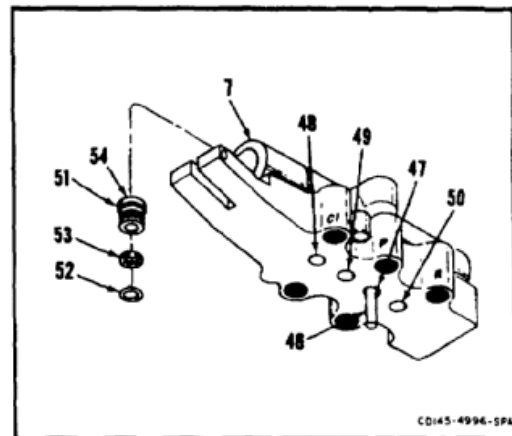

FOLLOW-ON MAINTENANCE:

None

END OF TASK

INITIAL SETUP**Applicable Configurations:**

Aircraft with **65**

Tools:

Hydraulic Repairer's Tool Kit, NSN 5180-00-323-4891
 Spanner Wrench Set
 Aircraft Mechanic's Tool Kit, NSN 5180-00-323-4692
 Soft Jawed Vise
 Wood or Plastic Dowel, 5/16 Inch X 6 Inches
 Technical Inspection Tool Kit, NSN 5180-00-323-5114

Materials:

Plastic Bags (E78)
 Barrier Material (E80)
 Dry Cleaning Solvent (E162)
 Paper Tag (E264)
 Locquick Primer (E295.1)
 Sealing Compound (E342.3)
 Masking Tape (E388)

Personnel Required:

Aircraft Pneudraulics Repairer
 Inspector

References:

Appendix E

Equipment Condition:

Off Helicopter Task

General Safety Instructions:**WARNING**

Dry cleaning solvent (E162) is combustible and toxic. Avoid contact with skin, eyes, or clothing. Avoid inhaling. Use only with adequate ventilation, away from open flame. In case of contact, immediately flush skin or eyes with water for at least **15 minutes**. Get medical attention for eyes.

WARNING

Sealing compound (E342.3) can irritate skin and cause burns. Avoid contact with skin, eyes, or clothing. In case of contact, immediately flush skin or eyes with water for at least **15 minutes**. Get medical attention for eyes.

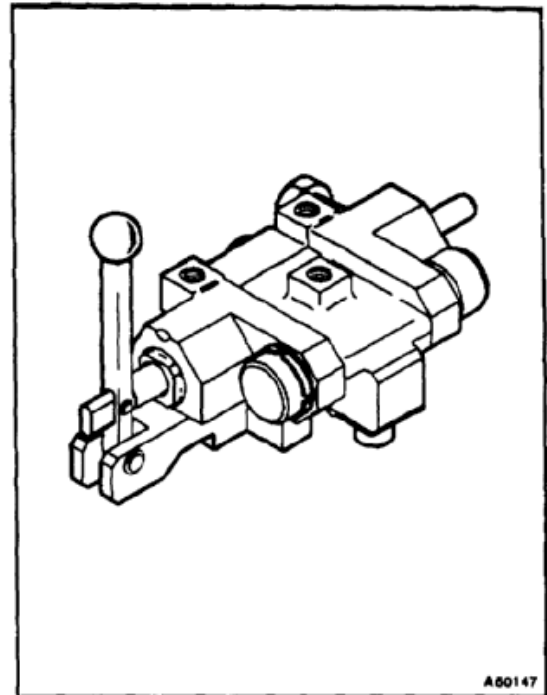
**WARNING**

Hydraulic fluids (E197 and E199) are toxic. They can irritate skin and cause burns. Avoid inhaling. Use only with adequate ventilation. Avoid contact with skin, eyes, or clothing. In case of contact, immediately flush skin or eyes with water for at least **15 minutes**. Get medical attention for eyes.

NOTE

General inspection criteria (Task 7-1.1) for obvious damage applies unless otherwise stated.

Make sure disassembled parts remain clean and free of any foreign matter. Place any parts to be left disassembled, in clean plastic bags (E78), or wrap in barrier material (E80).

Seal bearing surfaces are those surfaces against which packings and other seals ride, excluding seats in which they are installed.

1. Position handle (1) **90°** to input piston (2).
2. Remove safety wire from four seal glands (3), and remove seal glands and four springs (4) from valve body (5).
3. Remove packings (6) and backup rings (7) from inside valve body (5).
4. Inspect seal bearing surfaces of each seal gland (3). These surfaces must not be nicked, dented, or scratched.
5. Inspect seats inside valve body (5) that receive packings (6) and backup rings (7). The seats must be free of dents, nicks, or scratches.

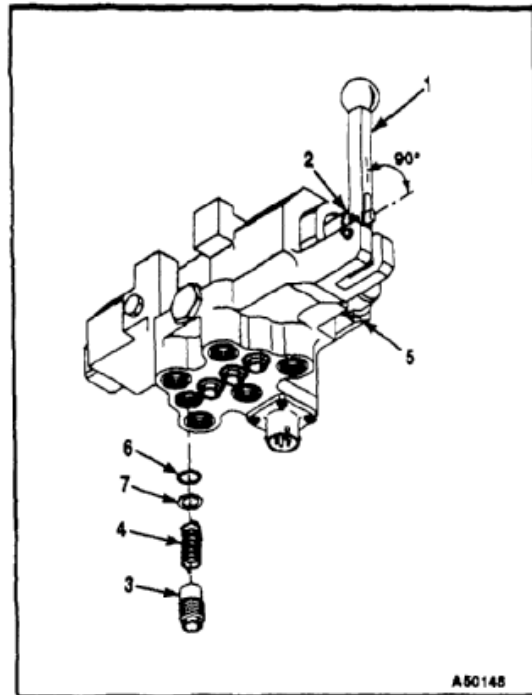

NOTE

It is not necessary to remove knob (8) if it is tight and secure on handle (1).

6. Check security of knob (8) on handle (1). If knob is loose, remove knob and check security of set screw (9). If set screw is loose, proceed as follows:
 - a. Remove set screw (9), and check condition of threads on set screw and inside handle (1). Replace set screw if threads are damaged.
 - b. Clean threads of set screw (9), handle (1), and knob (8), with dry cleaning solvent (E162). Threaded areas must be completely clean of dirt, oil, and any foreign matter.

NOTE

Sealing compound (E342.3) takes **24 hours** to cure. Cure time can be reduced using locquick primer (E295.1).

- c. Apply **one drop** of sealing compound (E342.3) to threads of set screw (9) that thread into handle (1).

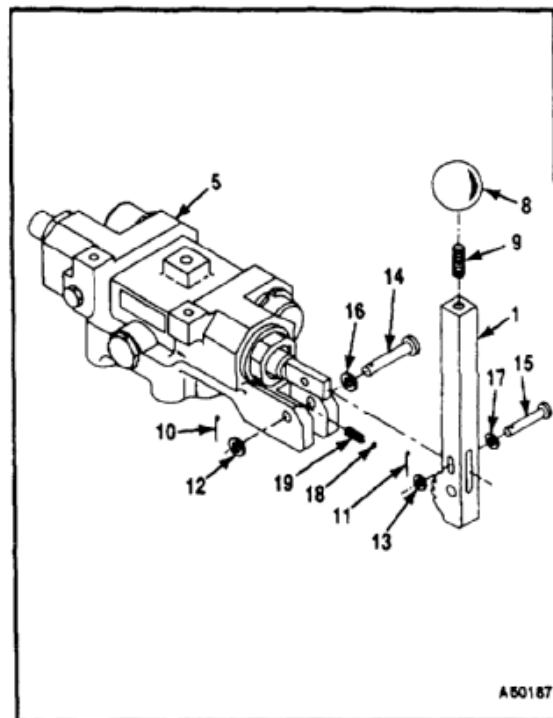

7-267.1 DISASSEMBLE AND INSPECT 145HS775 RAMP CONTROL VALVE (Continued)

7-267.1

- d. Thread set screw into handle until it bottoms.
 - e. Apply **one drop** of sealing compound (E342.3) to exposed threads of set screw (9) that will thread into knob (8).
 - f. Screw knob (8) onto handle until it bottoms.
7. Remove cotter pins (10 and 11) and washers (12 and 13) from pins (14 and 15).
 8. Remove pin (14) and washer (16) from handle (1).

NOTE

To prevent detent ball (18) from springing free, take care when removing pin (16) from handle (1).

9. Remove pin (15) and washer (17) and carefully remove handle (1) from between clevis of valve body (5). Grasp detent ball (18) if it exits valve body.
10. Remove bail (18) and spring (19) from valve body (5).

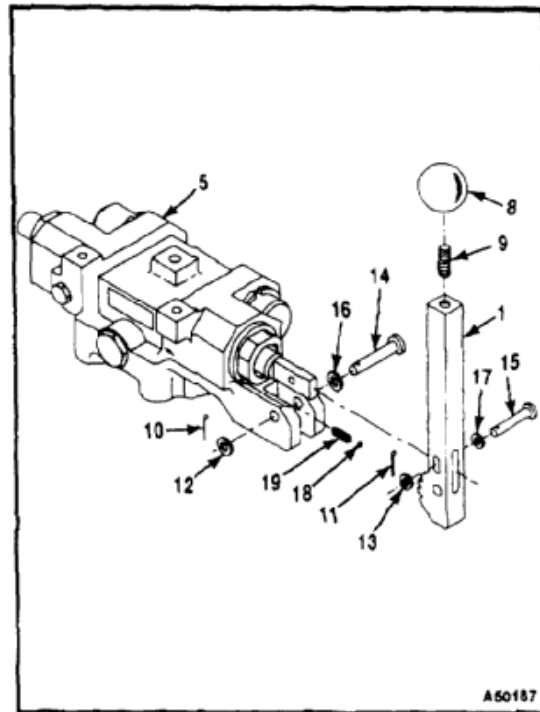

11. Remove lockwire from plug (20) and relief valve assembly (21).
12. Remove plug (20) and relief valve assembly (21) from valve body (5).
13. Remove packing (22) from plug (20).
14. Remove packings (23 and 24) and piston (cap) seal (25) from relief valve assembly (21).
15. Inspect seats that receive packings (23 and 24) and piston seal (25) on relief valve assembly (21). The seats shall be free of nicks or scratches.
16. Inspect plunger (26) on relief valve assembly (21) for condition and freedom of movement.

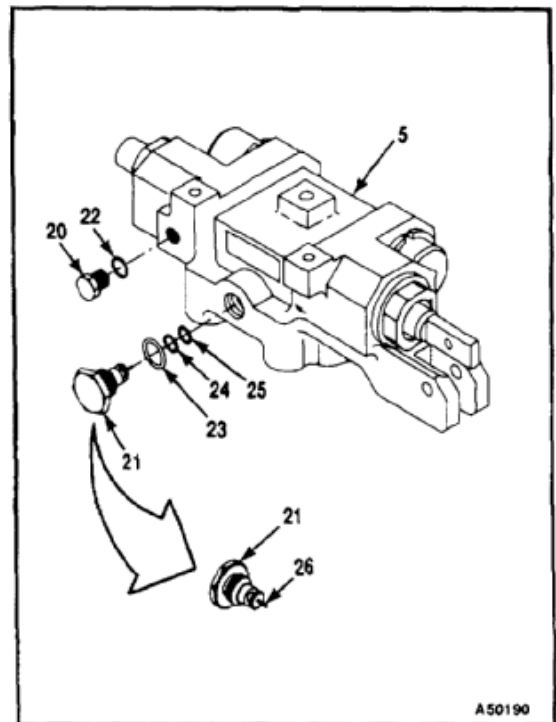

17. Remove lockwire from gland nuts (27 and 28).
18. Remove gland nuts (27 and 28) from each end of valve body (5). Take care not to scratch or nick surfaces of valve body or gland nuts against which packings slide.
19. Inside gland nuts (27 and 28), remove packings (29 and 30) and piston (cap) seals (31 and 32).
20. Inspect seats inside gland nuts (27 and 28) that receive piston seals (31 and 32). There shall be no nicks or scratches.
21. Remove rod scrapers (33 and 34) from gland nuts (27 and 28).
22. Inspect seats that receive rod scrapers (33 and 34). There shall be no nicks or scratches.
23. Remove T ring seals (35 and 36) from gland nuts (27 and 28).
24. Inspect seats that receive T ring seals (35 and 36). There shall be no nicks or scratches.
25. Remove packings (37, 38, 39, and 40) and backup rings (41, 42, 43, and 44) from gland nuts (27 and 28).
26. Inspect seats that receive packings (37, 38, 39, and 40) and backup rings (41, 42, 43, and 44). There shall be no nicks or scratches.

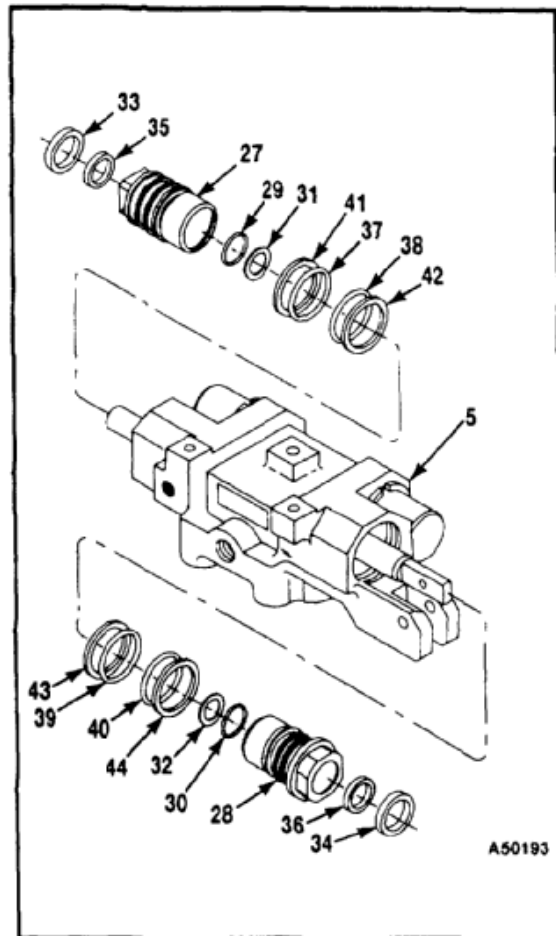



Special care must be taken when removing the piston and slide assemblies to ensure that bearing surfaces are not scratched, dented, or marred in any way.

To avoid damaging bearing surfaces of valve body (5), make sure to support rod and Input pistons (46 and 45) when performing the following procedures.

27. Remove rod piston as follows:
 - a. Carefully pull input piston (45) outward from valve body (5) until it reaches its limit (refer to position 1). This will move floating piston (47) to the end of its travel on rod piston (46).
 - b. While looking through port (48) in valve body assembly (7), carefully pull rod piston (46) back in opposite direction of input piston (45) (refer to position 2), until pin assembly (49) is observed through port (refer to view A).
 - c. Obtain a flat tip screw driver small enough to go through port (48) and into pin assembly (49). Put a small piece of masking tape (E388) on the tip of the screw driver to retain pin assembly (49).
 - d. Slide screw driver through port (48) and press into pin assembly (49). Unscrew pin assembly from rod piston (46) and slide assembly (50), and remove pin from inside valve body (5).
28. Remove rod piston (46) and floating piston (47) from valve body (5).
29. Remove retainer (51) from floating piston (47).
30. Remove floating piston (47) from rod piston (46).
31. Remove packing (52) and piston (cap) seal (53) from rod piston (46).
32. Inspect bearing surface (54) on rod piston (46), and seat (55) that receives packing and piston seal (52 and 53). There shall be no nicks, dents, or scratches.
33. Remove input piston (45), slide assembly (50), roller cage (56), and rollers (57) from valve body (5) by carefully pulling on input piston. To prevent damage to bearing surfaces of valve body and avoid dislodging rollers and cage, take care to support slide assembly as it leaves the valve body.

NOTE

Pins (58 and 59) are pressed into washers (60 and 61) to ensure proper orientation inside valve body (5) at installation. Pins need not be replaced unless they are loose.

34. Remove washers (60 and 61) with pins (58 and 59). Take care not to damage any bearing surfaces inside valve body (5).
35. Remove thrust plate (62) from inside valve body (5).
36. Remove roller cage (56) and rollers (57) from slide assembly (50).
37. Remove retainer (63) from floating piston (64), and slide floating piston off input piston (45).
38. Remove packing (65) and rod (cap) seal (66) from input piston (45).
39. Remove pin assembly (67) from input piston (45) and slide assembly (50).
40. Inspect bearing surface (68) of input piston (45) and seat (69) that receives packing and cap seals (65 and 66). There shall be no nicks, dents, or scratches.
41. Inspect slide assembly (50) as follows:
 - a. Inspect bearing surfaces of slide assembly (50). There shall be no nicks, dents, or scratches.
 - b. Check installation of threaded inserts (70 and 71) in slide assembly (50). Threads are to be undamaged and below surface **1/4 to 1/2 turn** below outer surface.

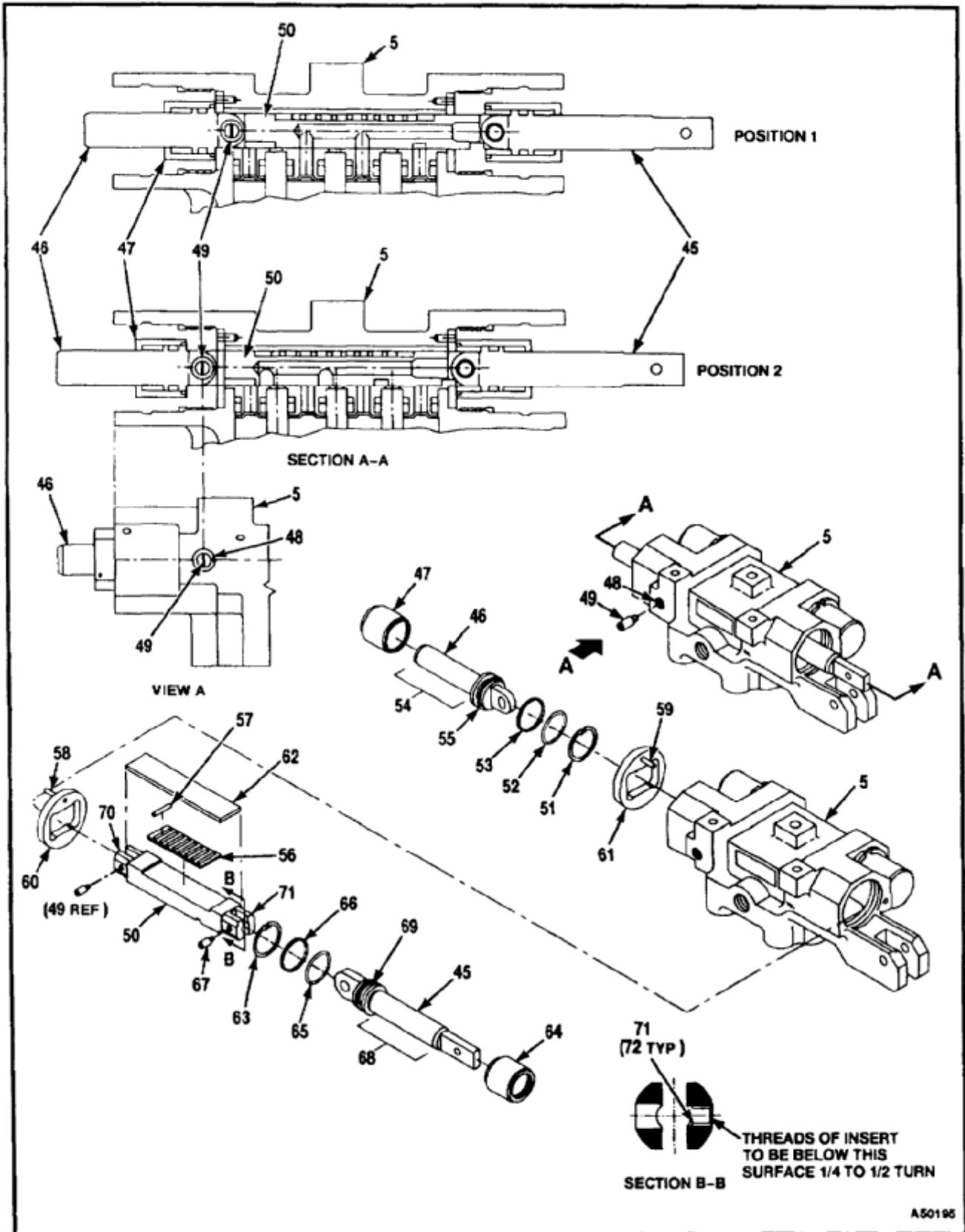

CAUTION

Be careful when removing shear seals. Do not mar bearing surfaces of valve body.

42. Insert wood or plastic dowel (72) into ports (73, 74, 75, and 76), and push four shear seals (77) into valve body (5). Remove seals from inside of valve.
43. Remove packings (78) and backup rings (79) from shear seals (77).
44. Inspect face (80) of each shear seal (77). Faces of shear seals shall be free of nicks or scratches.

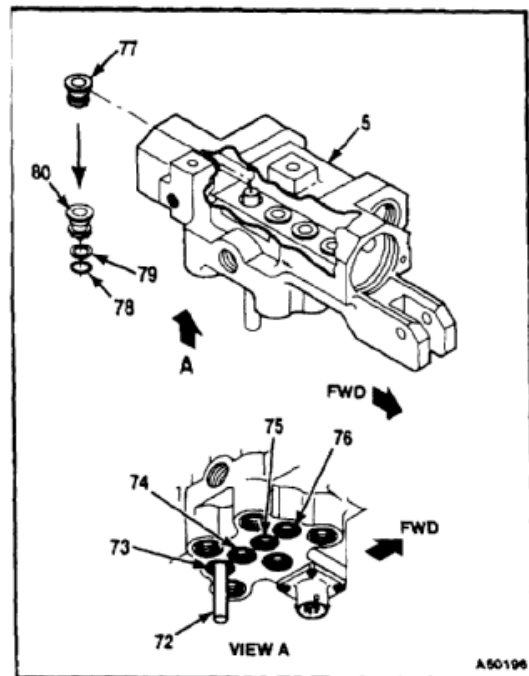
**NOTE**

If a solenoid valve must be replaced, go to step 45.

45. Remove seals from both solenoid valves (81) as follows:
 - a. Remove lockwire from locking ring (82) and remove locking ring.

CAUTION

Do not pull hard on solenoid valve as this could damage valve wiring.

- b. Withdraw solenoid valve (81) from valve body (5) until valve poppet (83) just clears body. Do not pull hard on valve.
- c. Remove T ring seals (84, 85, and 86). Inspect seal seats for nicks or scratches. None are permitted.

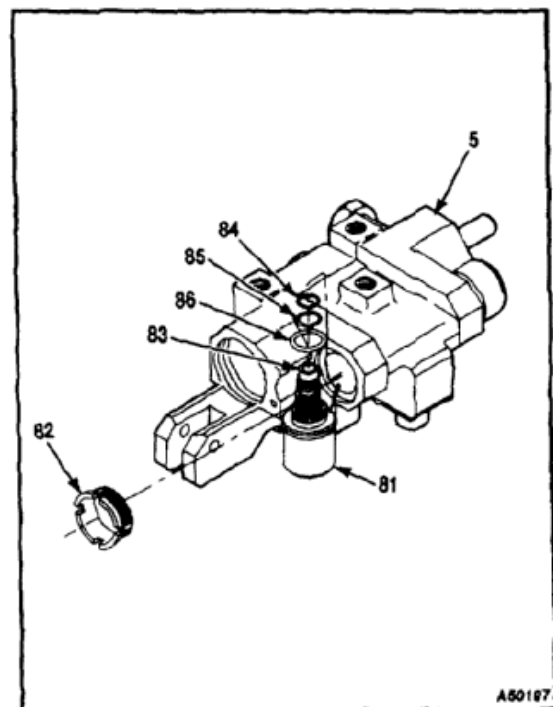

NOTE

Due to potting requirements, it may be necessary to replace connector and both diodes if it becomes necessary to remove wires from back of connector.

46. Proceed as follows to remove solenoid valves (81) and connector (87) from valve body (5).
 - a. Remove lockwire from four screws (88) and remove screws from connector and valve body.
 - b. Remove connector (87) from valve body (5). It may be necessary to pry connector from valve body due to use of potting compound to secure and insulate wires and diodes behind connector.
 - c. Remove potting compound from around wires, diodes (89 and 90), and back of connector (87).
 - d. Unsolder wires and diodes (89 and 90) from back of connector (87). Make sure all potting is removed from wires of solenoid valve (81) being removed.

- e. Remove lockwire from locking ring (82) and remove locking ring.



Do not pull hard on solenoid valve as this could damage valve wiring.

- f. Remove solenoid valve(s) (81) from valve body (5) and pull wires from body.
47. Inspect seal bearing surfaces (91, 92, 93, and 94), and threaded areas (95, 96, 97, and 98) inside valve body (5). Seal bearing surfaces shall be as smooth as possible and free of nicks or scratches. Threads shall be free of contamination and not damaged in any way.

FOLLOW-ON MAINTENANCE:

None

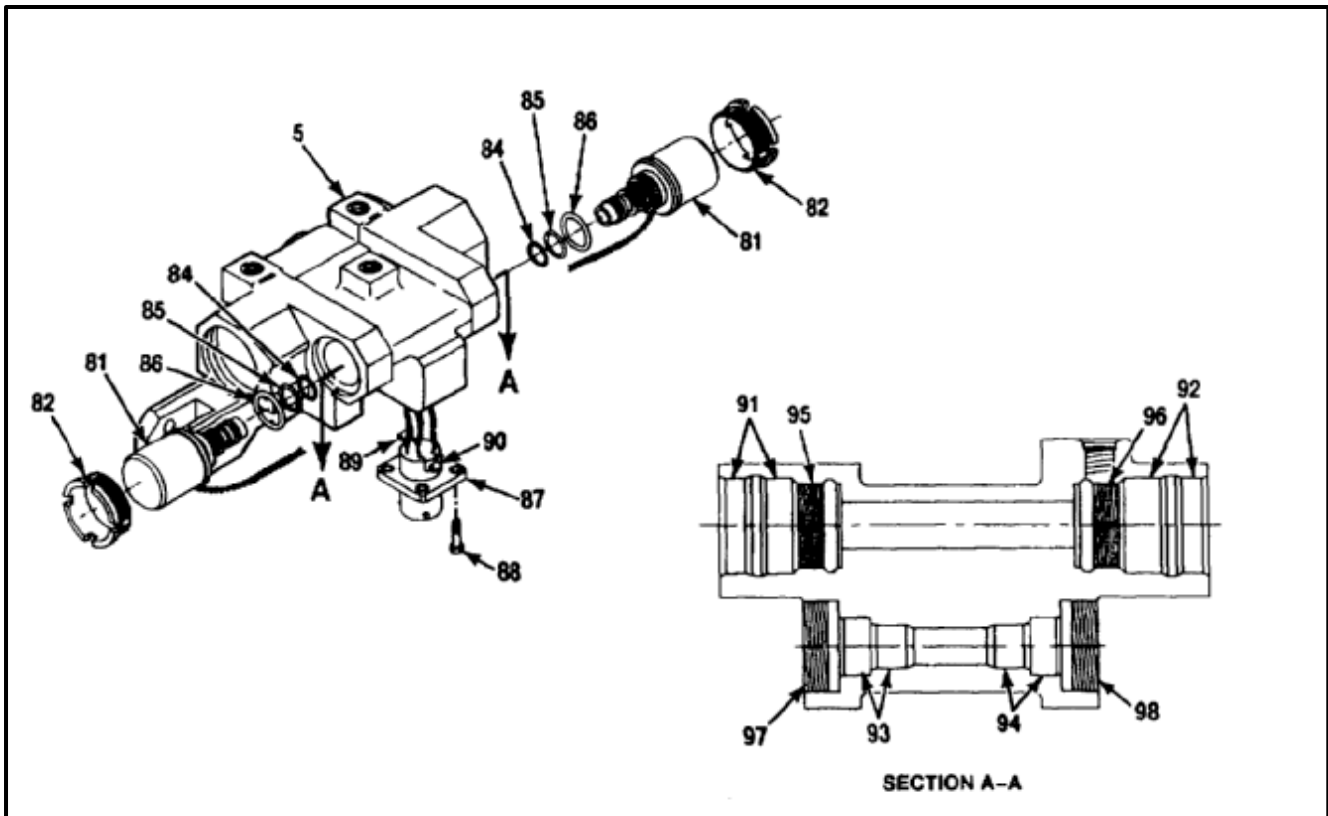

END OF TASK

INITIAL SETUP

Applicable Configurations:

Without **65**

Tools:

- Hydraulic Repairer's Tool Kit, NSN 5180-00-323-4891
- Spanner Wrench Set
- Spanner (APP E-3)
- Wood Dowel, 3/8 Inch X 8 Inches

Materials:

Lockwire (E229)

Parts:

- Packings
- Retainers
- Cotter Pins

Personnel Required:

Aircraft Pneudraulics Repairer
Inspector

References:

TM 55-1520-240-23P
Appendix E

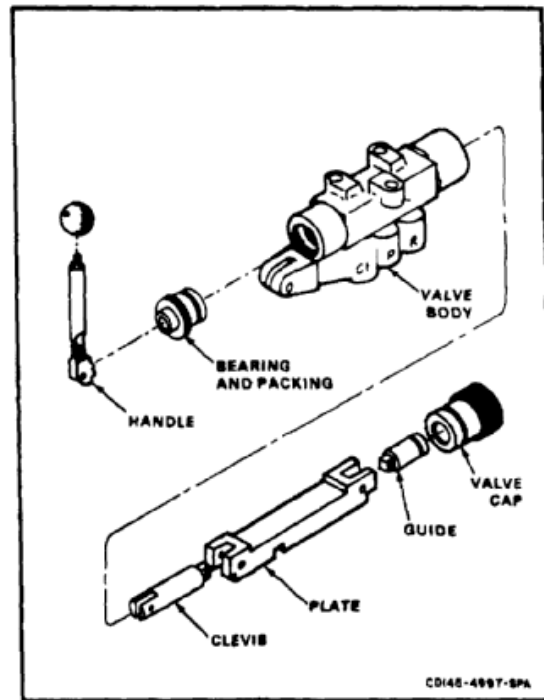

NOTE

Pressure port poppet has deeper bevel than cyl 1, cyl 2 and cyl 3 poppets.

1. Install retainer (1) and packing (2) on pressure port poppet (3).
2. Slide poppet (3) into bore of valve body (4) and position in pressure port (6).

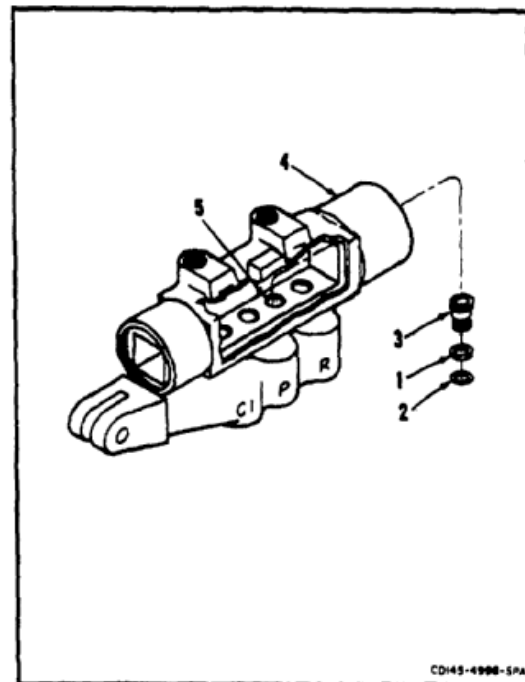

3. Press poppet (3) into pressure port (5). Use dowel (6).

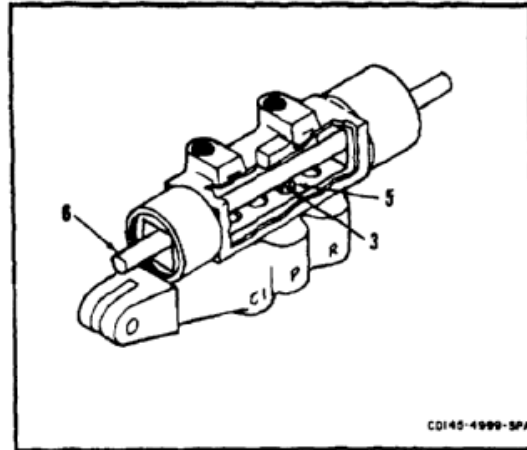

4. Install one retainer (7) and one packing (8) on each of three poppets (9).
5. Slide first poppet (9) into bore of body (4) and position in port (10).
6. Press poppet (9) into port (10). Use dowel (6).
7. Slide second poppet (9) into bore of body (4) and position in port (11).
8. Press poppet (9) into port (11). Use dowel (6).
9. Slide third poppet (9) into bore of body (4) and position in port (12).
10. Press poppet (9) into port (12). Use dowel (6).

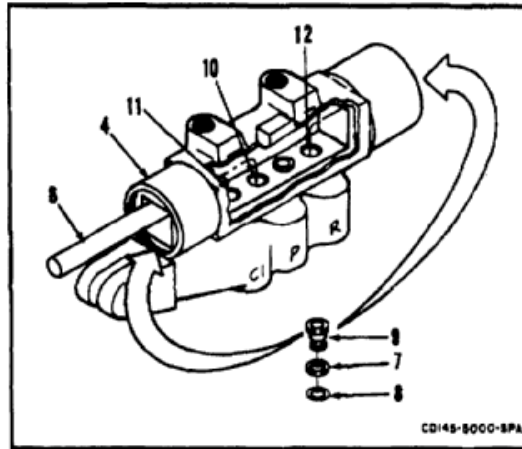

11. Install one retainer (13) and one packing (14) on each of four valve caps (15).
12. Install one spring (16) and one valve cap (16) in each of four ports (5, 10, 11, and 12).

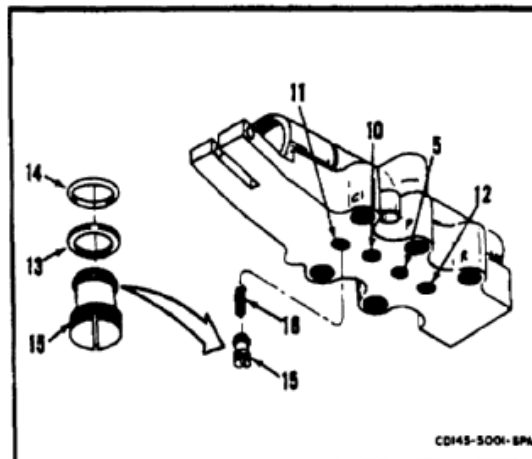

13. Position plate (17) with notch (18) to left.
14. Position clevis (19) in plate (17). Install pin (20).
15. Position guide (21) in plate (17). Install pin (22).
16. Install packing (23) and two retainers (24) on guide (21).

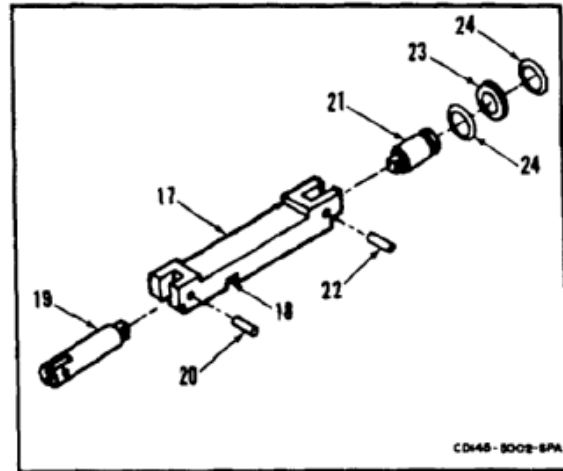

17. Install retainer (25) and packing (26) on valve cap (27).
18. Install valve cap (27) on guide (21).
19. Install space plate (28) on plate (17). Install nine rollers (29) in space plate (28).
20. Install bearing plate (30) on plate (17).

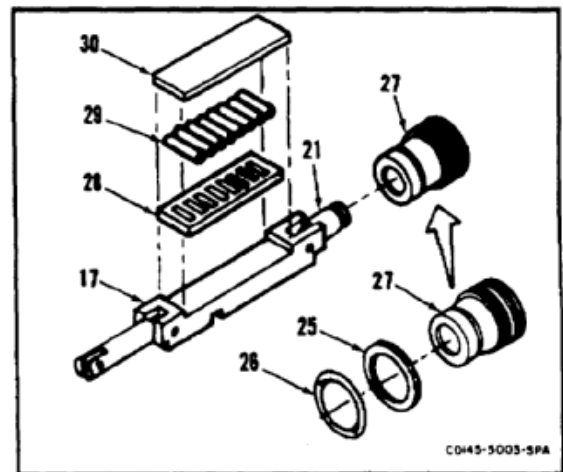

21. Install plate (17), clevis (19) end first, in body (4) until valve cap (27) contacts body.
22. Install valve cap (27) in body (4).

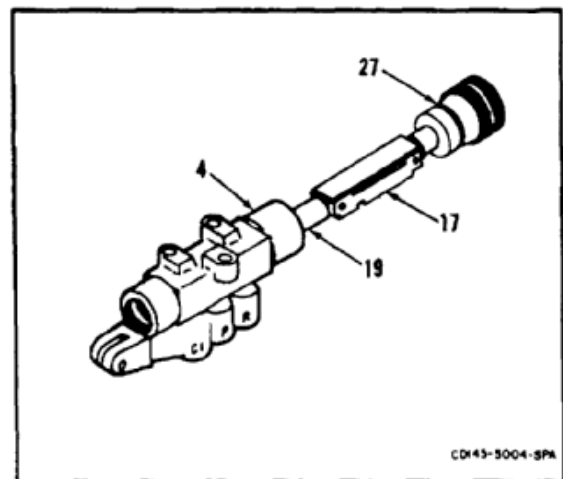

23. Install packing (31) and retainer (32) in bearing and packing (33).
24. Install retainer (34) and packing (35) on bearing and packing (33).
25. Slide bearing and packing (33) over clevis (19) and install in body (4). Use spanner (36) (APP E-3).

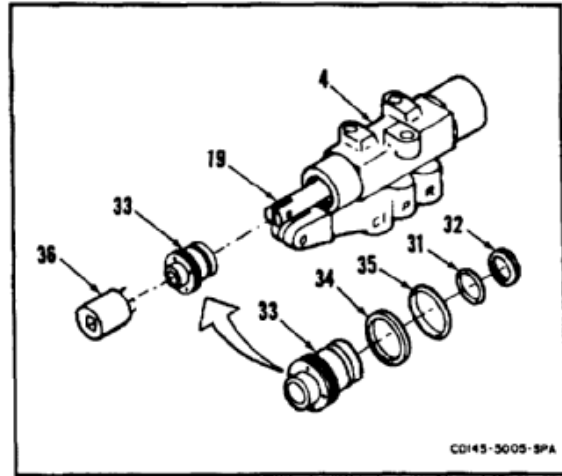

26. Install spring (37) and ball (38) in body (4).
27. Position handle (39) in body (4). Install washer (40) and pin (41) through body and bottom hole in handle.
28. Install washer (42) and cotter pin (43) on pin (41).
29. Align to hole in handle (39) with hole in clevis (19). Install washer (44) and pin (45).
30. Install washer (46) and cotter pin (47) on pin (45).

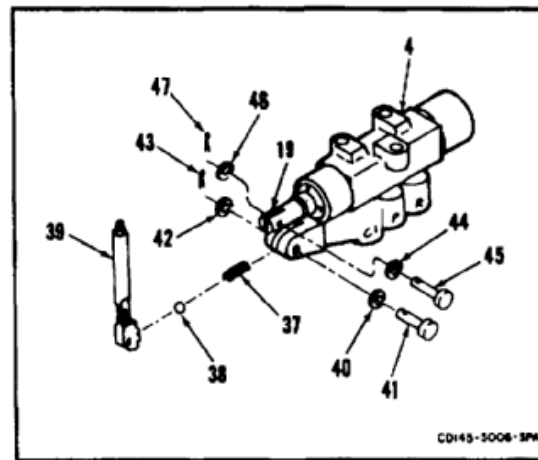

31. Install knob (48) on handle (39).
32. Position handle (39) **90°** to clevis (19).
33. Install two retainers (49) and packing (50) on plug (51).
34. Install two retainers (52) and packing (53) on plug (51).
35. Install pin (54) in plug (51).
36. Install spring (55), seat (56), ball (57), and plug (51) in port (58).
37. Lockwire plug (51). Use lockwire (E229).

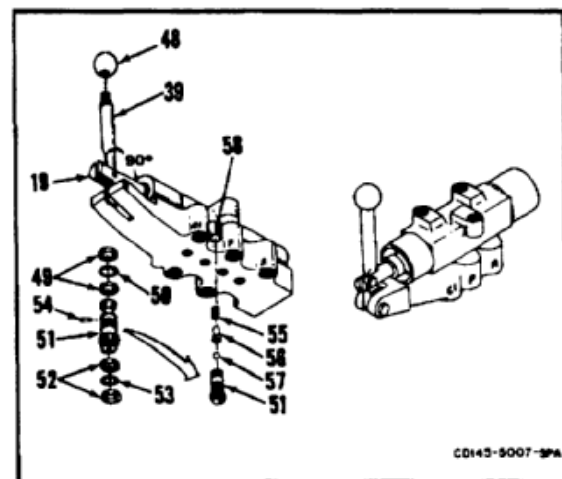

INSPECT

FOLLOW-ON MAINTENANCE:

Test ramp control valve (Task 7-269).

END OF TASK

INITIAL SETUP

Applicable Configurations:

Aircraft With **65**

Tools:

- Hydraulic Repairer's Tool Kit, NSN 5180-00-323-4891
- Spanner Wrench Set
- Seal Installation Tool, T-1FA13043-007 (T173)
- Seal Sizing Tool, T-1FA13043-007 (T174)
- Seal Installation Tool, TF1FA1305592 (T175)
- Seal Sizing Tool, TF1FA105593 (T176)
- Seal Sizing Tool, TF1FA1305594 (T177)
- Torque Wrench, 0 to 150 Inch-Pounds
- Wood Dowel, 3/8 Inch X 8 Inches

Materials:

- Plastic Bags (E78)
- Barrier Material (E80)

- Hydraulic Fluid (E199)
- Lockwire (E229)
- Petrolatum (E274)
- Sealant (E332.1)
- Sealant (E332.2)

Parts:

- Packings
- Retainers
- Ring Seals
- Piston (Cap) Seals
- Cotter Pins

Personnel Required:

- Aircraft Pneudraulics Repairer
- Inspector

References:

TM 55-1520-240-23P

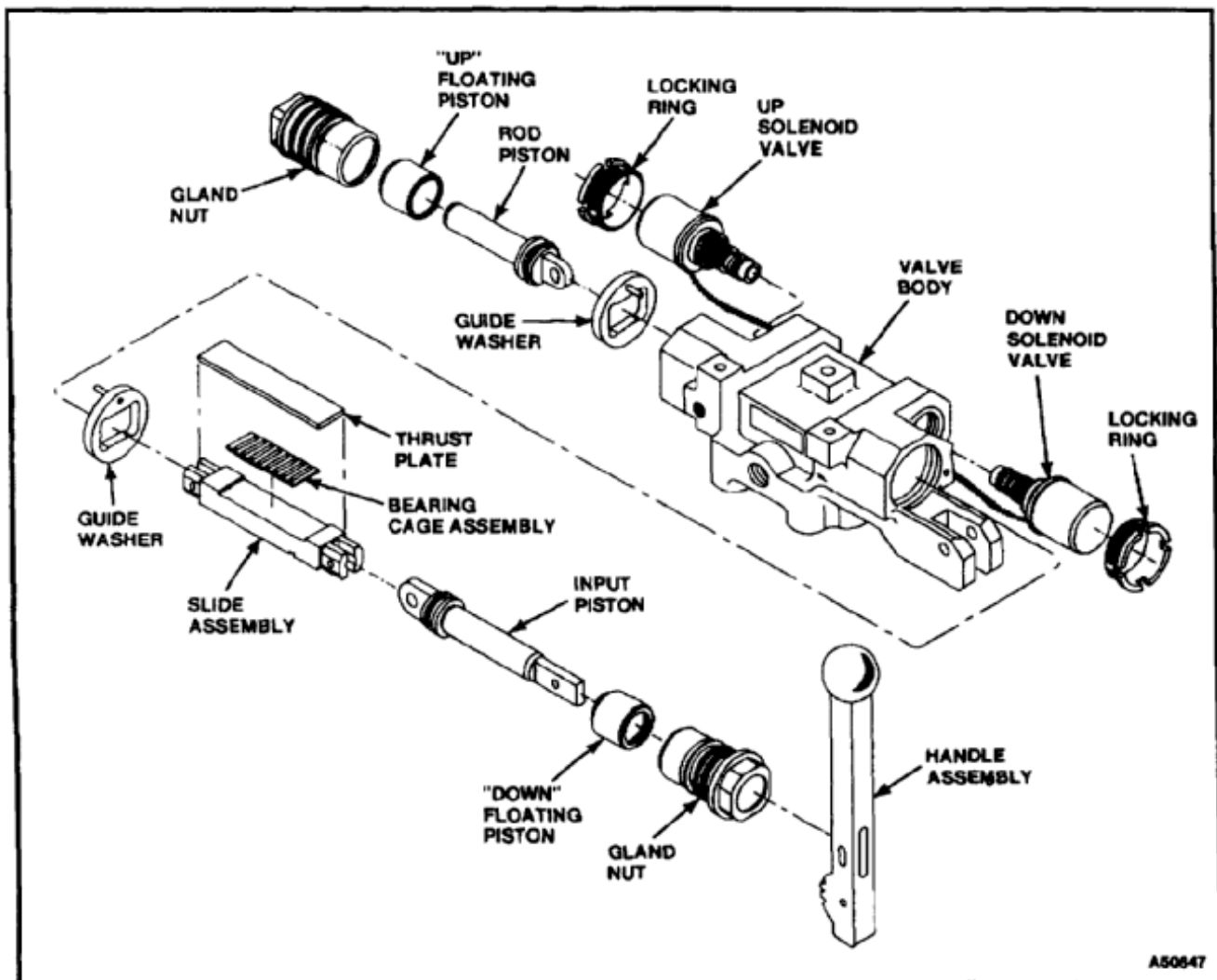

General Safety Instructions:

WARNING

Hydraulic fluids (E197 and E199) are toxic. They can irritate skin and cause burns. Avoid inhaling. Use only with adequate ventilation. Avoid contact with skin, eyes, or clothing. In case of contact, immediately flush skin or eyes with water for at least **15 minutes**. Get medical attention for eyes.

CAUTION

Work area where valve will be maintained must be clean and free of dirt and oil, and any other foreign matter that could contaminate components of the valve. If contaminated, valve will not operate properly.

1. Observe the following procedures throughout this task:
 - a. Unless only hydraulic fluid (E199) is specified, lubricate all packings and seals with hydraulic fluid (E199) or petrolatum (E274) before installation. Be careful not to damage seals or packings. Threaded components to be lubricated shall also have their threads lubricated prior to installation and torquing.
 - b. Make sure preassembled and loose parts remain clean and free of contamination by keeping them in clean plastic bags (E78), or wrapped in barrier material (E80) until needed.
 - c. Make sure that all seal bearing surfaces remain clean and free of any nicks or scratches. Seal bearing surfaces are those surfaces rubbed by packings and seals during operation.
2. Install four shear seals (1) as follows:
 - a. Install packing (2) and retainer (3) over packing on each shear seal (1).
 - b. Install shear seal (1) in bore of valve body (4) and position in applicable port (5).

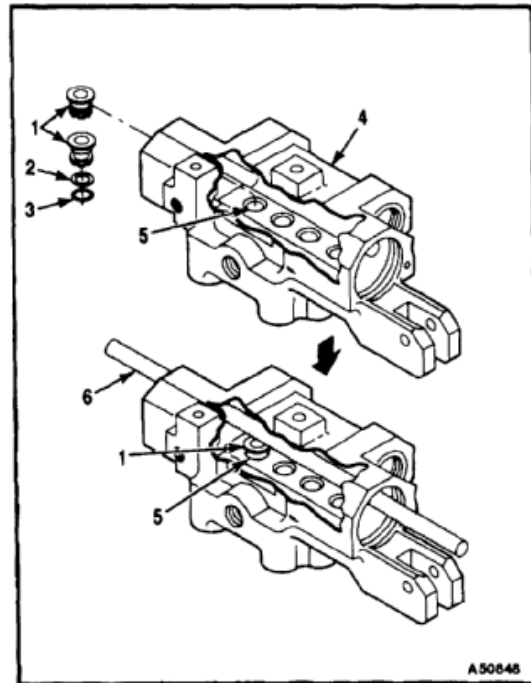

CAUTION

Do not mar face of shear seals during installation.

- c. Press shear seal (1) into port (5), using a plastic or hard wooden dowel (6). Apply even pressure on each side of dowel until shear seal seats in port.
3. Install plugs in shear seal and tubing ports on bottom of valve to prevent contamination.

4. Lubricate and install packing (7) on relief valve assembly (8) under head of relief valve.
5. Lubricate and install packing (9) in seat (10) of relief valve assembly (8).
6. Install piston (cap) seal (11) over packing (9) as follows:
 - a. Lubricate piston (cap) seal (11) and installation tool (T173) with hydraulic fluid (E199).
 - b. Slide piston (cap) seal (11) over tool (T173) until it reaches edge of tool.
 - c. Move tool (T173) over shaft of relief valve assembly (8). Hold piston (cap) seal (11) and pull back on tool. Make sure piston (cap) seal fits properly over packing (9).
 - d. Lubricate sizing tool (T174) with hydraulic fluid (E199), and slide sizing tool back and forth over shaft of relief valve assembly (8) and piston (cap) seal (11). Repeat as required to make sure seal is properly seated on packing (9).
7. Lubricate and install relief valve assembly (8). Torque valve **133 to 147 inch-pounds**.
8. Lockwire relief valve assembly (8) to valve body (4). Use lockwire (E229).
9. Lubricate seal flanges (12 and 13) of input and rod pistons (14 and 15), packings (16 and 17), and piston seals (18 and 19) with hydraulic fluid (E199).

CAUTION

Special care must be taken when installing packings and piston (cap) seals on input and rod pistons. If seals are damaged, valve will bypass internally and fail to work properly.

10. Install packings (16 and 17) in seats of seal flanges (12 and 13) on input and rod pistons (14 and 15).
11. Lubricate and install piston (cap) seals (18 and 19) over packings (16 and 17). Use installation and sizing tools (T175 and T176) to install piston seals in same manner as described in step 6.

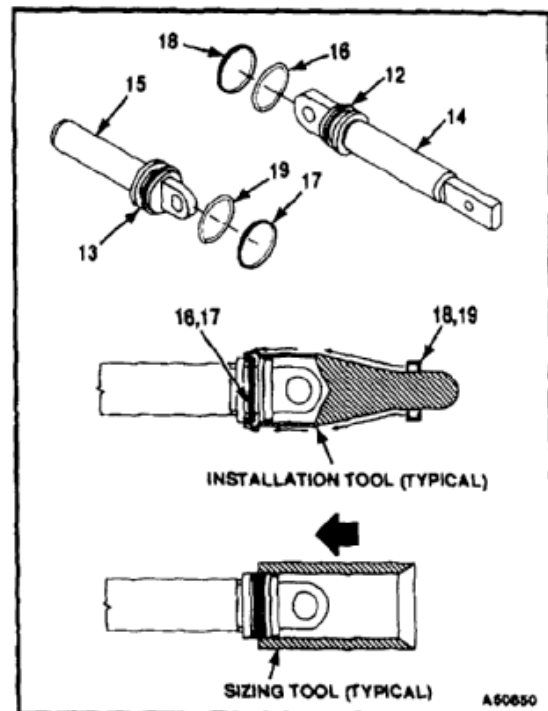
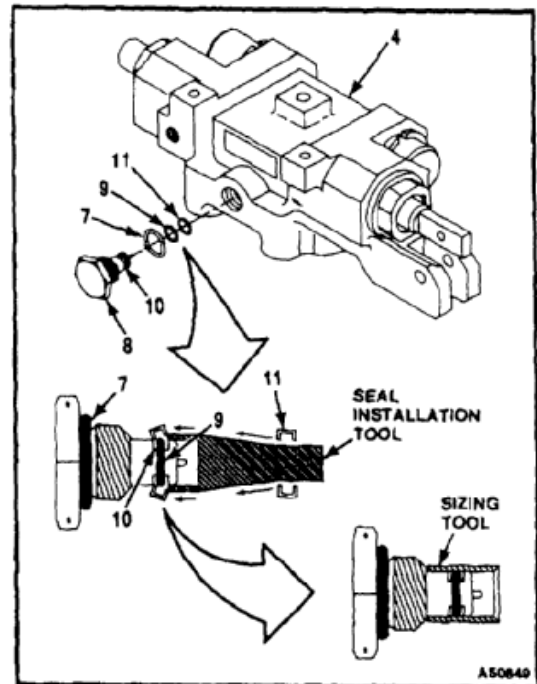

12. Install floating pistons (20 and 21) on input and rod pistons (14 and 15) as follows:
 - a. Lubricate input and rod pistons (14 and 15), floating pistons (20 and 21), and piston seals (18 and 19) with hydraulic fluid (E199).
 - b. Slide floating pistons (20 and 21) over input and rod pistons (14 and 15), until floating pistons contact seal flanges (12 and 13). Flanged end of floating pistons shall face opposite end of clevises of input and rod pistons.
13. Lubricate retainers (22 and 23) with hydraulic fluid (E199) and install retainers in seats (24 and 25) of floating pistons (20 and 21).
14. Lubricate rod piston assembly (15), and place in clean plastic bag (E78) or wrap in barrier material (E80) until needed.

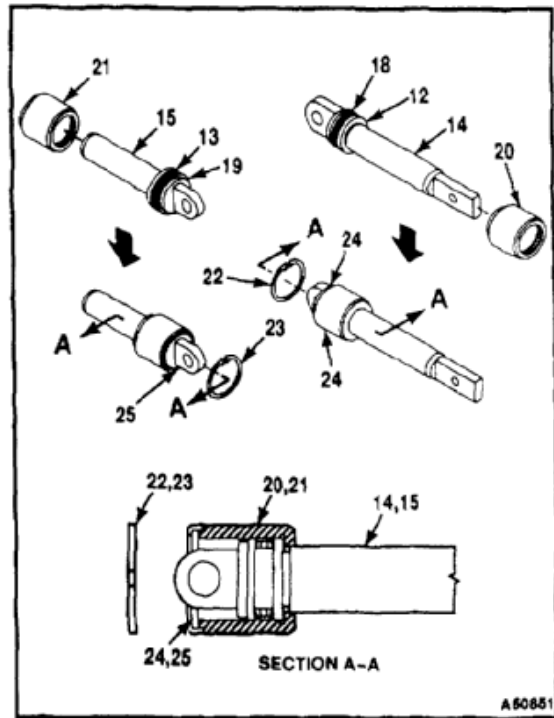

15. Connect slide assembly (26) to clevis (27) of input piston (14) as follows:
 - a. Move floating piston (20) towards handle end of input piston (14) until retainer (22) seats against seal flange (12).
 - b. Fit clevis (27) of input piston (14) between flanges at grooved end of slide assembly (26).
 - c. Install pin assembly (28) lubricated with hydraulic fluid (E199), through flanges of slide assembly (26), and clevis of input piston (14).
 - d. Torque pin assembly (28) **15 to 20 inch-pounds**.

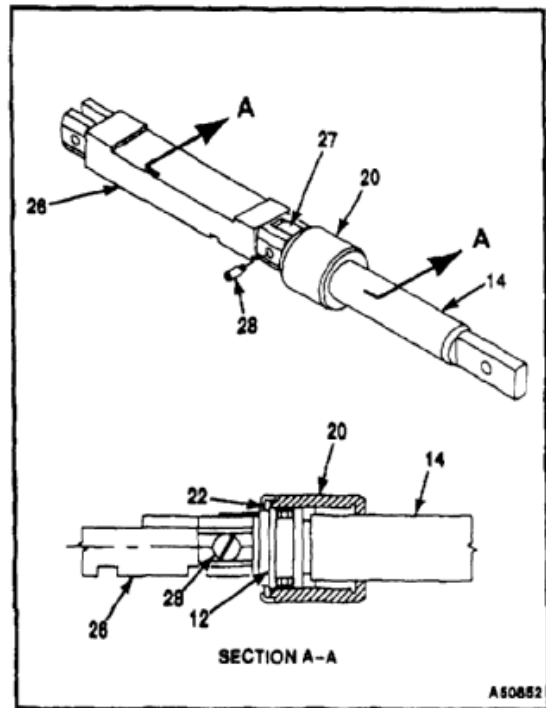

16. Lubricate guide washers (29 and 30) and thrust plate (31) with hydraulic fluid (E199).
 17. Install thrust plate (31) inside valve body (4). Temporarily lay valve on its side or top to keep thrust plate in place.
- NOTE**
- A dowel pin is pressed into each retaining washer. Replace pins only if loose or damaged. If new pin will not fit tight in washer, replace both washer and pin.
- Holes in valve body that receive dowel pins, are drilled for a clearance fit.
18. Install guide washers (29 and 30) in valve body (4). Make sure dowel pins (32 and 33) seat properly in holes (34 and 35).
 19. Lubricate eight roller bearings (36), bearing cage (37), input piston and slide assemblies (14 and 26), with hydraulic fluid (E199).
 20. Install eight roller bearings (36) in cage (37), on slide assembly (26).
 21. Lubricate and install backup rings (38 and 39) packings (40, 41, and 42), T ring (43), and gland seal (44) on and in gland nut (45).
 22. Lubricate and carefully install piston (cap) seal (46) over packing (42) inside gland nut (45).
 23. Lubricate sizing tool (T177) with hydraulic fluid (E199) and slide sizing tool (T177) into gland nut (45) to seat piston (cap) seal over packing.
 24. Upright valve body (4), and carefully install slide and input piston assemblies (14 and 26) with bearing cage (37) and bearings (36).
 25. Lubricate input piston (14), piston (cap) seal (46), T ring (43), gland seal (44), and surfaces inside valve body (4) with hydraulic fluid (E199).
 26. Install gland nut (45) and torque **195 to 215 inch-pounds**.
 27. Move input piston (14) back and forth to make sure parts operate without binding. If piston binds, disassemble and repair as necessary.
 28. Lockwire gland nut (45) to valve body (4). Use lockwire (E229).

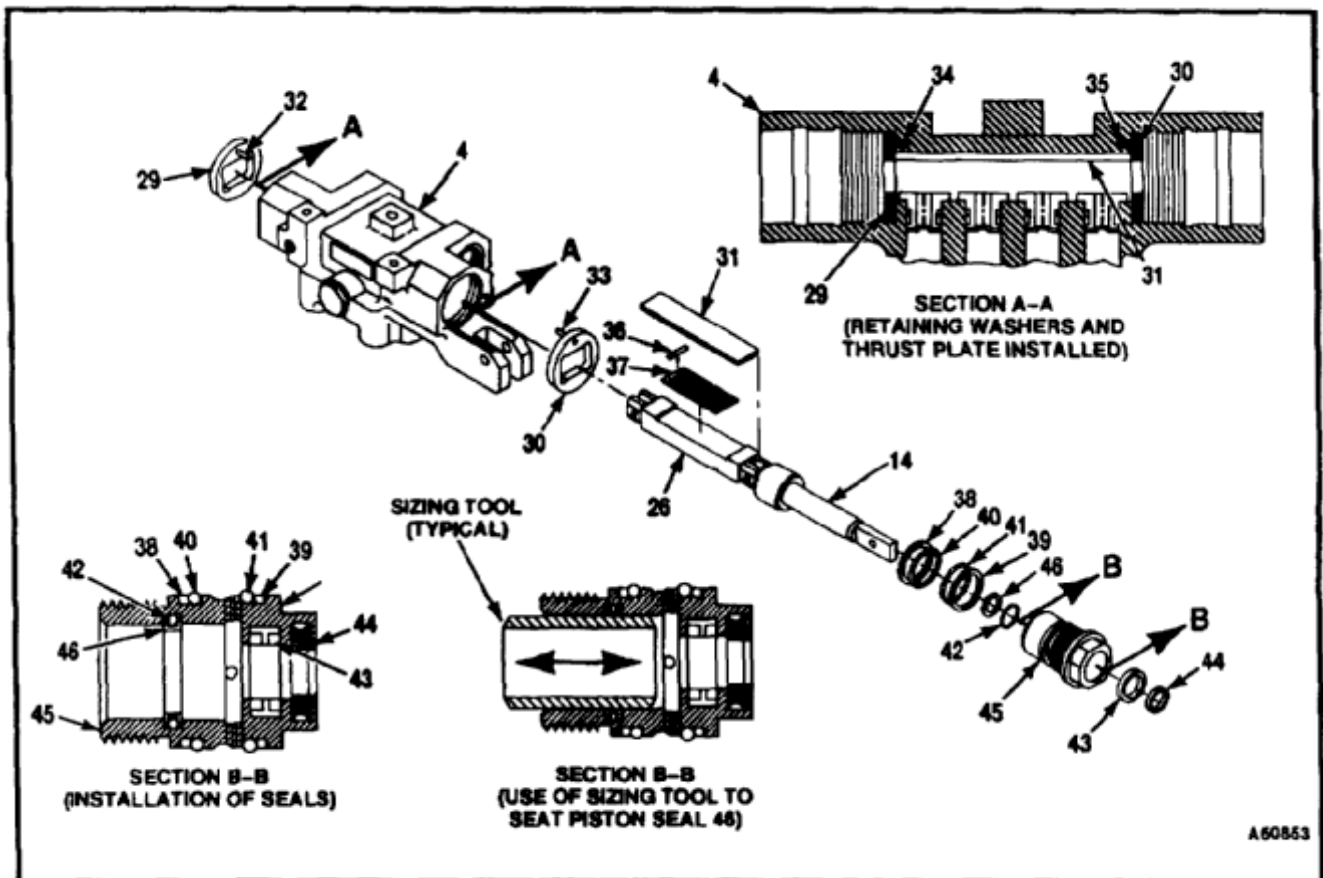

A60853

29. Install rod piston assembly (15) as follows:
 - a. Slide input piston (14) towards far end of valve body (4) until attachment flanges (47) of slide assembly (26) can be seen through port (48) in valve body.
 - b. Slide floating piston (21) on rod piston (15) back until retainer seats against seal flange (13).
 - c. Lubricate pin assembly (49) with hydraulic fluid (E199).
 - d. Install rod piston (15) with clevis (50) between flanges (47) of slide assembly (26). Looking through port (48) of valve body (4), line up hole in clevis with holes in flange of slide assembly and hold in position.
 - e. Install pin assembly (49) through port (48), and into flanges (47) of slide assembly (26), and clevis (50) of rod piston (15). Torque pin assembly **15 to 20 inch-pounds**.
30. Lubricate and install backup rings (51 and 52), packings (53, 54, and 55), T ring (56), and gland seal (57), on gland nut (58).
31. Lubricate and carefully install piston (cap) seal (59) over packing (55) inside gland nut (58). Lubricate sizing tool (T177) with hydraulic fluid (E199) and slide sizing tool into gland nut to seat piston (cap) seal over packing.
32. Lubricate shaft of rod piston (15), gland seal (57), T ring (56), piston (cap) seal (59), and internal surfaces of valve body (4) with hydraulic fluid (E199).
33. Install gland nut (58) and torque **195 to 215 inch-pounds**.
34. Lockwire gland nut (58) to valve body (4). Use lockwire (E229).

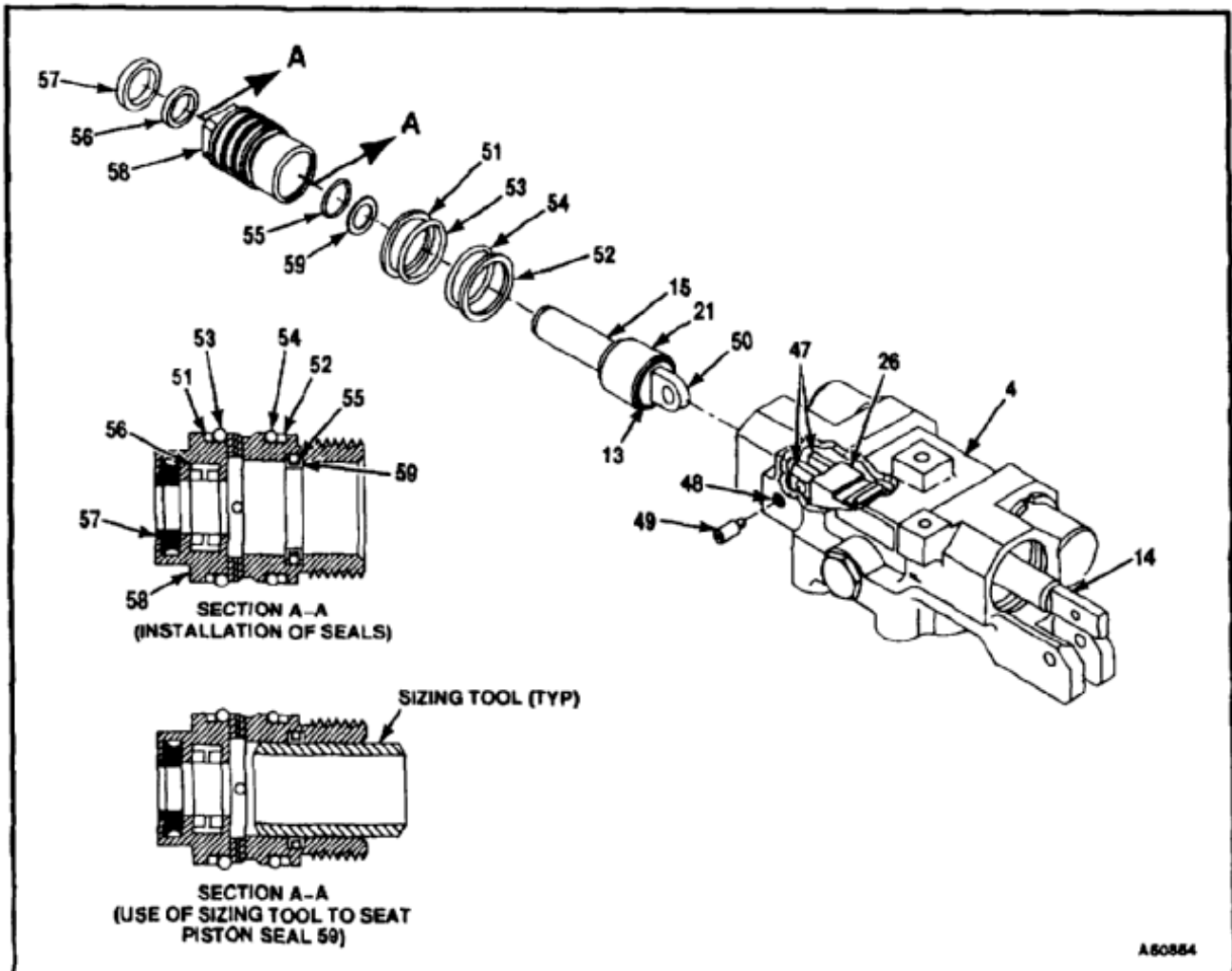

35. Lubricate four springs (60), packings (61), backup rings (62), and gland seals (63) with hydraulic fluid (E199).
36. Install four packings (61) and backup rings (62) in seats (64) of gland seal ports (65). Packings shall be on shear seal (1) side of backup ring.
37. Install springs (60) and gland seals (63) in valve body (4) wet with hydraulic fluid (E199). Torque gland seals **50 to 60 inch-pounds**.
38. Install lockwire across four gland seals (63). Use lockwire (E229).

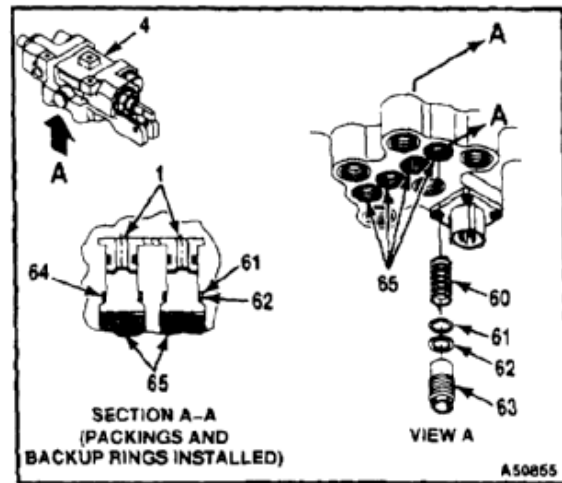

CAUTION

Do not pull on solenoid valves with wires installed, or damage to solenoids will occur.

NOTE

Do not disconnect solenoid valve wires from connector if only seals are to be replaced. Proceed to step 44 if a solenoid valve is being replaced.

39. Lubricate T rings (66, 67, and 68), poppet (69) of solenoid valve (70), locking ring (71), and inside of valve body (4) with hydraulic fluid (E199).
40. Install T rings (66, 67, and 68) in seats of poppet (69).
41. Install solenoid valve (70). Carefully feed extra wires into passage (72) of valve body (4) and make sure pin (73) of solenoid valve properly seats in valve body.
42. Install locking ring (71) lubricated with hydraulic fluid (E199). Torque locking ring **45 to 55 inch-pounds**.
43. Lockwire locking ring (71) to valve body (4). Use lockwire (E229).

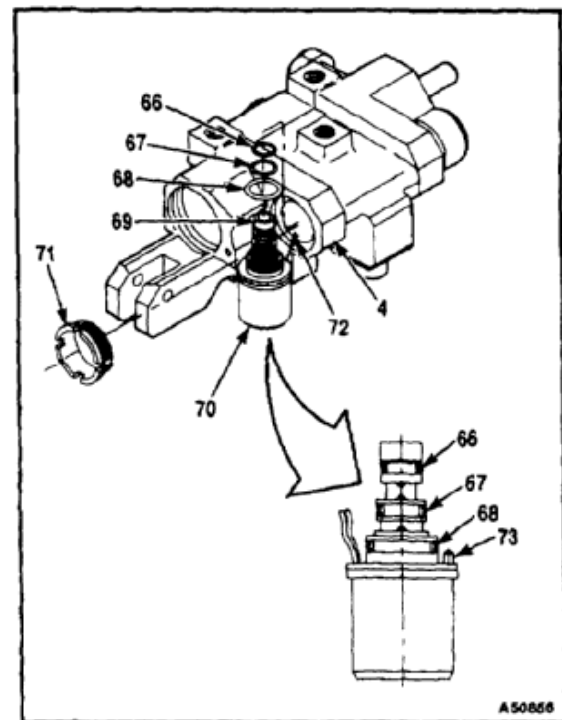

NOTE

If replacement of a solenoid valve is necessary, replacement of the connector may also be required if sealing compound around wires, diodes, and connector cannot be properly cleaned away.

44. Install new solenoid valve as follows:
 - a. Feed wires (74) through passage (72) in valve body (4) to connector (75), and install solenoid(s) (70) as described in steps 39 thru 43. Make sure pin (73) of solenoid housing (70) aligns with hole in valve body (4).
 - b. Solder wires and diode(s) to appropriate pins of connector (75).
 - c. Wrap masking tape (76) around back of connector (75). Form a pocket as high as the back of the connector, around wires and diodes.
 - d. Fill pocket with sealant (E332.1 or E332.2) and wait until sealant sets up enough to maintain its shape.
 - e. Peel off masking tape (76), and immediately install connector (75), forcing sealant and connector into cavity of valve body (4).
 - f. Lubricate and install four screws (77). Torque screws **15 to 20 inch-pounds**.
 - g. Lockwire screws (77). Use lockwire (E229).

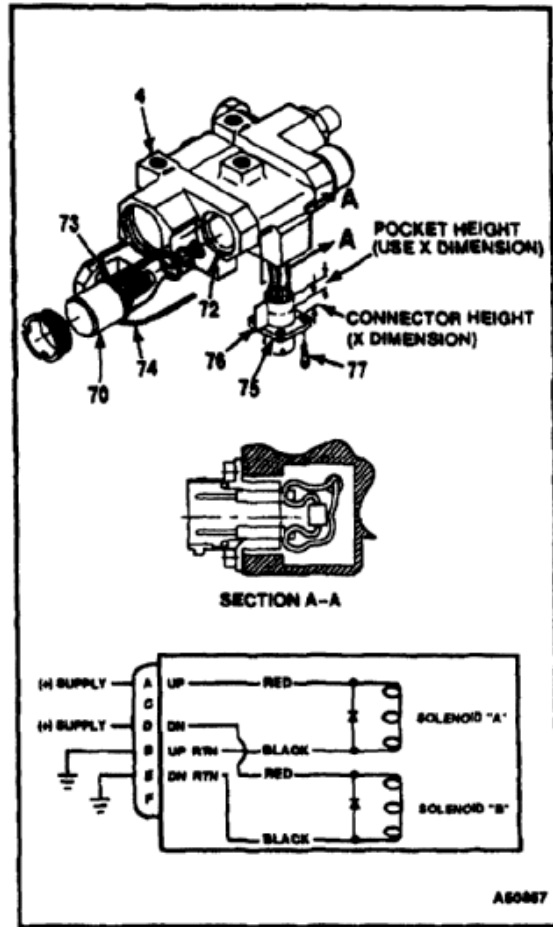

45. Lubricate spring (78) and detent ball (79) with hydraulic fluid (E199).
46. Install spring (78), detent ball (79), and handle (80) in valve body (4) between arms of valve body. Hold handle in place.
47. Install pin (81), washers (82 and 83), and cotter pin (84) through arms of valve body (4) and handle (80).
48. Install pin (85), washers (86 and 87), and cotter pin (88) through handle (80) and clevis of input piston (14).

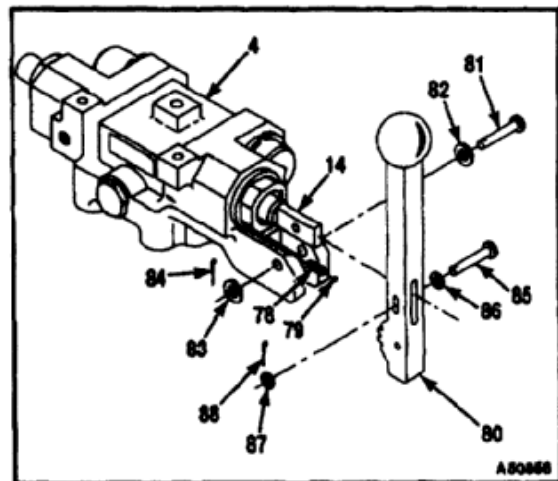

INSPECT

FOLLOW-ON MAINTENANCE:

Test ramp control valve (Task 7-269.1).

END OF TASK

INITIAL SETUP

Applicable Configurations:Without **65****Tools:**

Hydraulic Repairer's Tool Kit, NSN 5180-00-323-4891
 Hydraulic Test Stand
 Dial Indicating Scale, 0 to 25 Pounds
 Graduated Cylinder, 0 to 50 cc
 Flexible Hose, 1/4 Inch, 0 to 4500 psi

Materials:

None

Parts:

Pressure Caps

Personnel Required:

Aircraft Pneudraulics Repairer
 Inspector

Equipment Condition:

Off Helicopter Task
 Valve Installed in Crash Proof Box

General Safety Instructions:**WARNING**

Control valve must be installed in crash proof box before performing test. Otherwise, injury to personnel can occur.

WARNING

Hydraulic fluid (E199) is toxic. It can irritate skin and cause burns. Avoid inhaling. Use only with adequate ventilation. Avoid contact with skin, eyes, or clothing. In case of contact, immediately flush skin or eyes with water for at least **15 minutes**. Get medical attention for eyes.

WARNING

Hydraulic fluid ejected under pressure can cause injury to personnel. Hydraulic fluid sprayed into the air is a fire hazard.

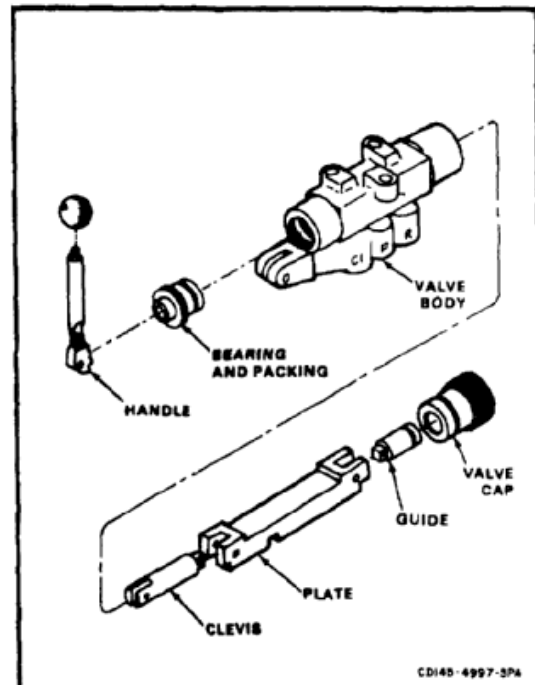

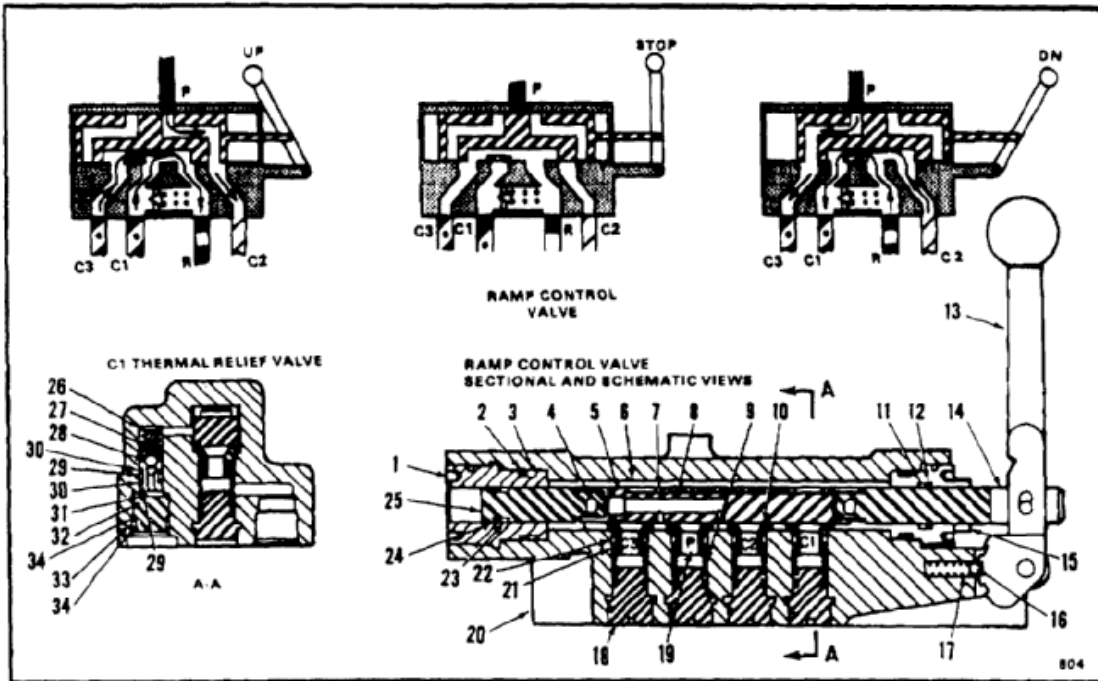

- | | | |
|-------------------|---------------------|---------------------|
| 1. End plug | 13. Handle | 24. Backup rings |
| 2. Backup rings | 14. Clevis rod | 25. Guide shaft |
| 3. Packing | 15. Plug | 26. Spring |
| 4. Dowel pin | 16. Detent ball | 27. Spring retainer |
| 5. Plate assembly | 17. Detent spring | 28. Ball |
| 6. Bearing plate | 18. Seal plug | 29. Packing |
| 7. Spacer | 19. Pressure poppet | 30. Backup rings |
| 8. Roller | 20. Body | 31. Pin |
| 9. Seal spring | 21. Backup rings | 32. Plug seat |
| 10. Poppet | 22. Packing | 33. Packing |
| 11. Packing | 23. Packing | 34. Backup rings |
| 12. Backup rings | | |

1. Connect test stand pressure hose (1) to pressure port (2) of valve (3).
2. Set handle (4) to position 2.
3. Install pressure caps on ports (5, 6, and 7).
4. Apply **3000 psi** to pressure port (2).

NOTE

Ramp control valve is cycled by setting handle from position 2, to position 1, to position 2, to position 3, to position 2.

5. Operate ramp control valve (3) through **25 cycles**. Check valve (3) for external leakage. Leakage shall not exceed **1 drop**.

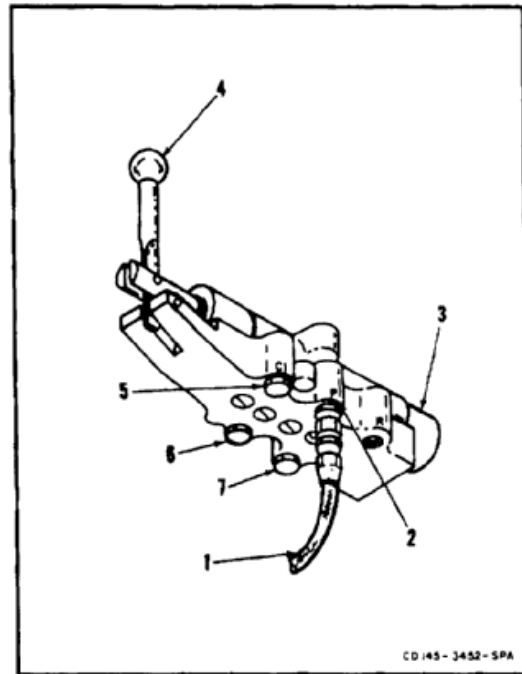

6. Connect test stand pressure hose (8) to return port (9).
7. Set handle (4) to position 1 or 3.
8. Apply **4500 psi** to ports (2 and 9). Check valve (3). There shall be no external leakage, failure, or permanent set.
9. Reduce pressure at ports (2 and 9) to **0 psi**.
10. Disconnect hose (1) from pressure port (2).
11. Disconnect hose (8) from test stand and return port (9).

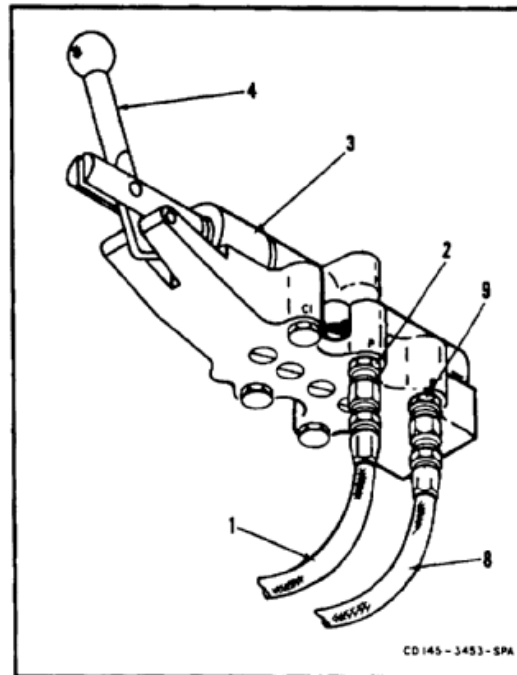

12. Remove pressure cap and connect pressure hose (1) to port C1 (5).
13. Set handle (4) to position 2.
14. Apply **3000 psi** to port C1 (5). Check return port (9) for leakage. Leakage at return port shall not be more than **1 drop per minute**.
15. Slowly increase pressure at port C1 (5) to **4350 psi**. Check leakage at return port (9). Leakage at return port shall not be more than **20 cc per minute**. Use graduated cylinder (10).
16. Reduce pressure at port C1 (5) to **3000 psi**. Check return port (9). Leakage at return port shall not exceed **1 drop per minute**.
17. Reduce pressure at port C1 (5) to **0 psi**.
18. Disconnect hose (1) from port C1 (5).

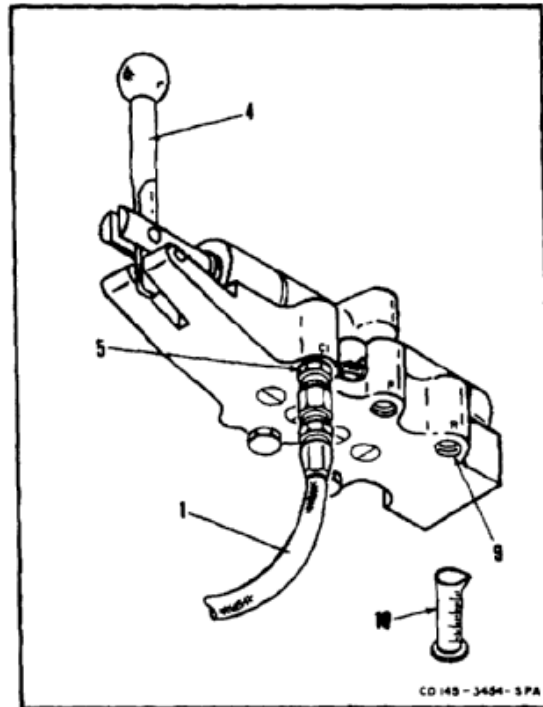

19. Remove pressure cap and connect pressure hose (1) to port C2 (6).
20. Make sure handle (4) is at position 2.
21. Apply **3000 psi** to port C2 (6). Check port (9). Leakage at return port shall not exceed **1 drop per minute**.
22. Reduce pressure at port C2 (6) to **0 psi**.

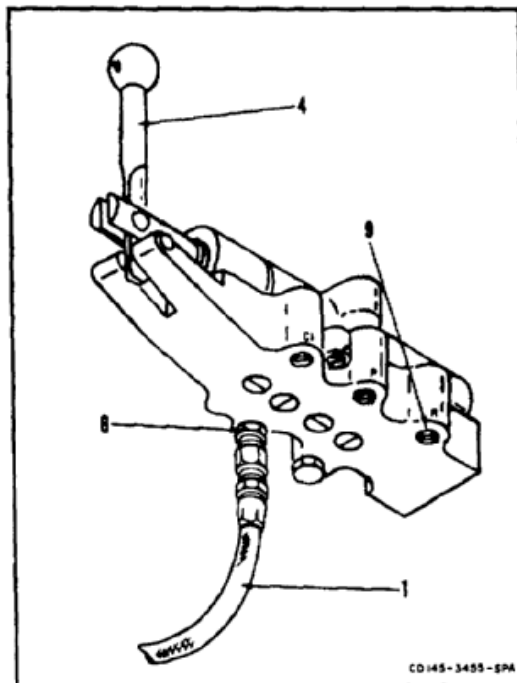

23. Disconnect pressure hose (1) from C2 port (6).
24. Connect pressure hose (1) to pressure port (2).
25. Make sure handle (4) is at position 2.
26. Apply **3000 psi** to pressure port (2). Check ports (5 and 6). Leakage at ports shall not exceed **1 drop per minute**.

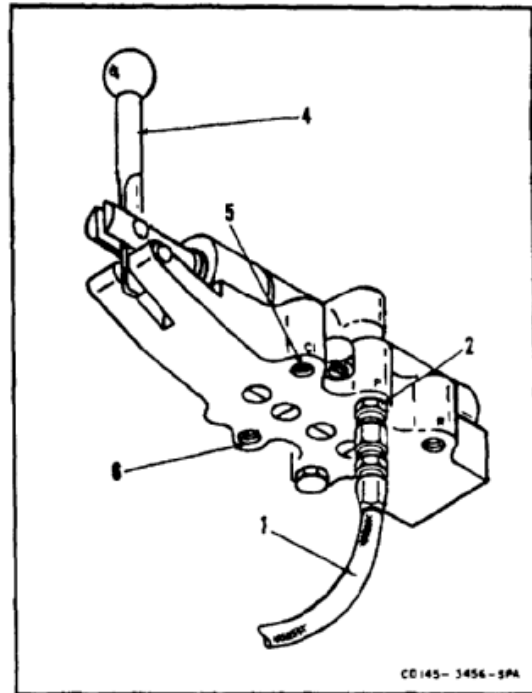

27. Install pressure cap on ports (5 and 6).
28. Set handle (4) to position 1.
29. Apply **3000 psi** to pressure port (2). Check return port (9). Leakage at return port shall not exceed **10 drops per minute**.
30. Reduce pressure at port (2) to **0 psi**.

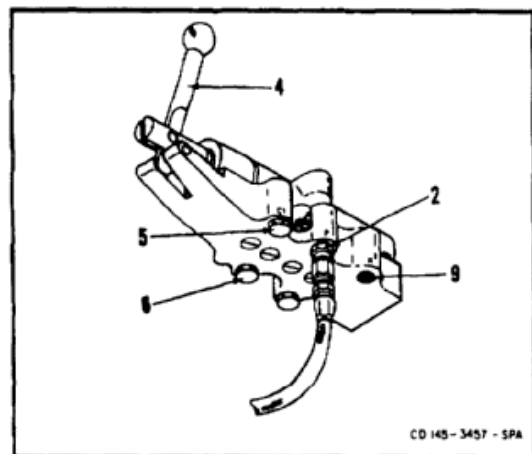

31. Set handle (4) to position 3.
32. Apply **3000 psi** to pressure port (2). Check return port (9) for leakage. Leakage at return port shall not exceed **10 drops per minute**.
33. Reduce pressure at port (2) to **0 psi**.

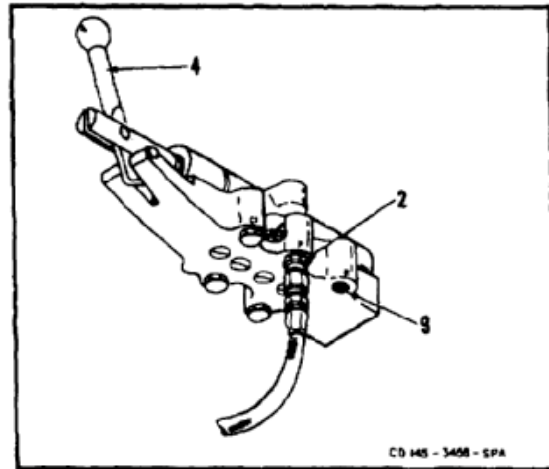

34. Install pressure cap on return port (9).
35. Set handle (4) to position 2.
36. Apply **3000 psi** to pressure port (2).
37. Place hook of scale (11) on handle (4). Pull handle and check force needed to move handle through all positions. Force needed to pull handle to each position shall be **5 to 20 pounds**.
38. Remove scale (11) from handle (4).
39. Reduce pressure at port (2) to **0 psi**.
40. Disconnect pressure hose (1) from pressure port (2).

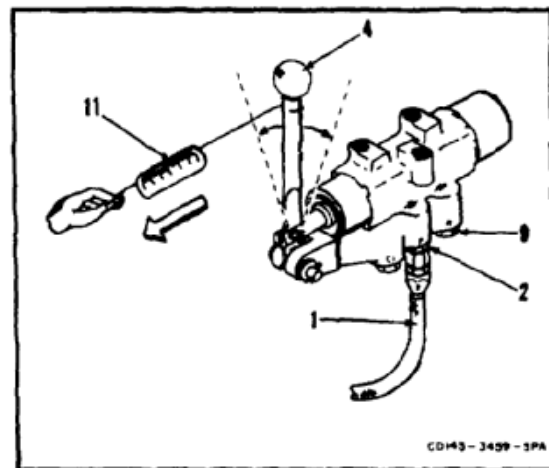
**INSPECT****FOLLOW-ON MAINTENANCE:**

None

END OF TASK

7-998

7-269.1 TEST 145HS775 RAMP CONTROL VALVE (AVIM)

7-269.1

INITIAL SETUP**Applicable Configurations:**Aircraft With **65****Tools:**

Hydraulic Repairer's Tool Kit, NSN 5180-00-323-4891
 Power Supply, 18 to 30 VDC
 Hydraulic Test Stand
 Dial Indicating Scale, 0 to 25 Pounds
 Graduated Cylinder, 0 to 50 cc
 Flexible Hose, 1/4 Inch, 0 to 4500 psi
 Ramp Control Valve Test Set (APP E-317)
 Test Fixture, Thermal Relief Valve (T178)
 Plug, Thermal Relief Valve Test (T179)
 Two Pressure Gages, 0 to 4500 psi
 Hand Valve
 Flowmeter

Materials:

Plastic Bags (E78)
 Barrier Material (E80)

Parts:

Pressure Caps

Personnel Required:

Aircraft Pneudraulics Repairer
 Inspector

References:

Task 7-268.1
 Appendix E

Equipment Condition:

Off Helicopter Task
 Valve Installed in Crash Proof Box

General Safety Instructions:**WARNING**

Control valve must be installed in crash proof box before performing test. Otherwise, injury to personnel can occur.

WARNING

Hydraulic fluid ejected under pressure can cause injury to personnel.
 Hydraulic fluid sprayed into the air is a fire hazard.

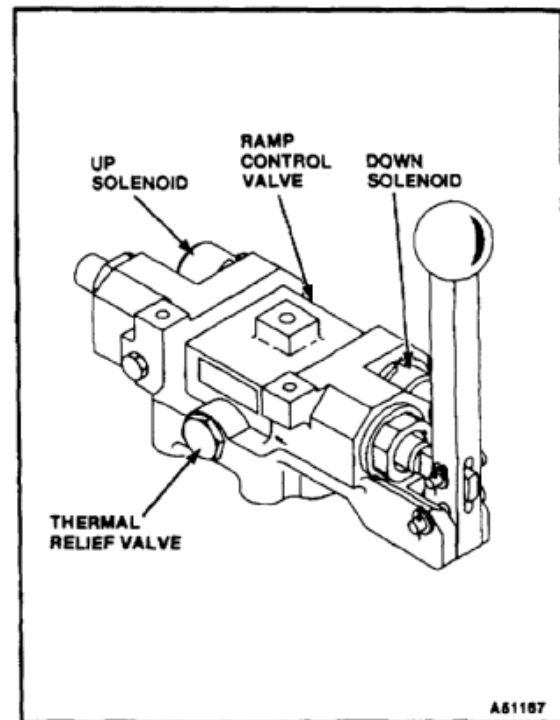
**WARNING**

Hydraulic fluid (E199) is toxic. It can irritate skin and cause burns. Avoid inhaling. Use only with adequate ventilation. Avoid contact with skin, eyes, or clothing. In case of contact, immediately flush skin or eyes with water for at least **15 minutes**. Get medical attention for eyes.

CAUTION

When applying pressure to the ramp control valve, do not exceed a rate of **25,000 psi per minute**, or damage to the valve could result.

NOTE

Same part number packings and piston seal are used on thermal relief valve and test plug. Refer to Task 7-268.1 for installation of seals.

1. Remove thermal relief valve (1) from ramp control valve (2).

NOTE

All tests assume that the ramp control valve is preconfigured with the appropriate unions in ports C1, C2, C3, F, and R. Pressure caps are to be installed on those unions.

2. Install new packings (3 and 4) and piston seal (5) on test plug (6) (T179).
3. Install test plug (6) (T179) in thermal relief valve port of ramp control valve (2). Torque plug to **133 to 147 inch-pounds**.

NOTE

Unions are shown in test block to clarify orientation of ports with thermal relief valve. Test block ports are manufactured to MS33649-04.

The thermal relief valve is not repairable and shall be replaced if it fails the following tests.

4. Install new packings (3 and 4) and piston seal (5) on thermal relief valve (1).
5. Install thermal relief valve (1) in port of test fixture (7) (T178). Torque thermal relief valve to **133 to 147 inch-pounds**.
6. Connect test stand pressure line (8) to inlet port (9) of test fixture (7) (T178).
7. Increase pressure to **3000 psig**. Leakage from test fixture outlet port (10), shall not exceed **1 drop per minute (dpm)**.
8. Continue to increase pressure until flow from outlet port (10) is **5 cc per min**. Inlet pressure shall be between **3850 and 4350 psig**.
9. Decrease inlet pressure to **3000 psig**, and measure leakage from outlet port (10). Leakage shall not exceed **1 drop per minute (dpm)**.
10. If the thermal relief valve (1) passes these tests, lubricate thermal relief valve with hydraulic fluid (E199) and place in plastic bag (E78). Replace thermal relief valve if it fails any of the above tests.

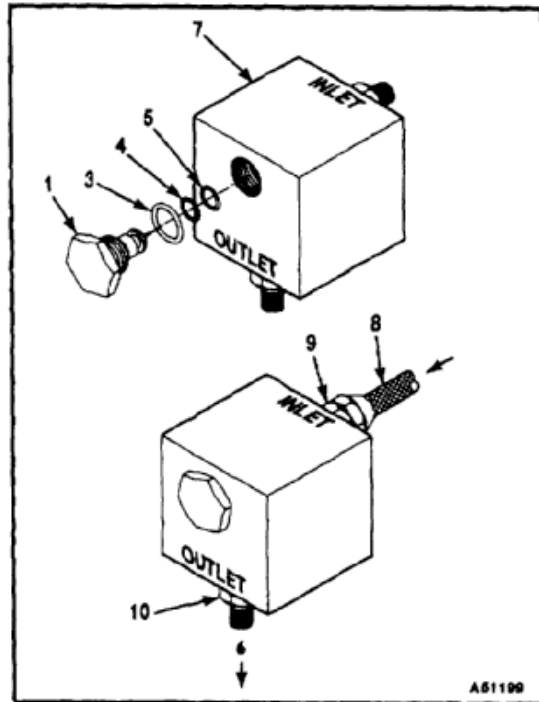
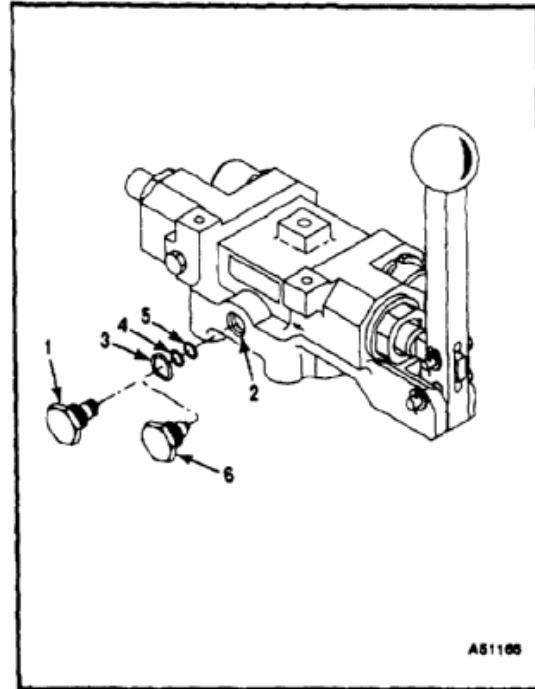

NOTE

During all tests, external static seal leakage shall not exceed a slight wetting insufficient to form a drop. Leakage from external dynamic piston seals shall not exceed **1 drop per 25 cycles** of motion.

Unless specified, the following tests shall be performed with test plug (T179) installed in place of thermal relief valve.

11. Install pressure caps (11, 12, 13, and 14) on ports C3, C2, C1, and P of ramp control valve (2).
12. Connect hydraulic pressure line (15) to return port R of ramp control valve (2).
13. Set handle (16) to position 2 (stop) with both solenoids de-energized, and apply **2515 psig** to pressure line (15) in return port R.
14. Hold pressure on return port R for **2 minutes** minimum. Check that external leakage is minimal with no permanent deformation of parts.
15. Remove pressure and disconnect pressure line (15) from return port R.
16. Remove caps (12, 13, and 14) from cylinder ports C2, and C1, and pressure port P.
17. Connect pressure lines (17, 18, and 19) to ports P, C1, and C2. Leave return port R (20) open to atmosphere and cap (11) on cylinder port C3.
18. Connect ramp control valve test set (E317) (21) to ramp control valve (2) and power supply. Set power supply to provide **30 vdc**.
19. Set PWR switch (22) to ON, ramp SOLENOID VALVE SELECT switch (23) to BOTH, and ramp control valve handle (16) to position 2 (stop). Both UP and DN SOLENOID lights (25 and 26) shall come on, indicating power is applied to both solenoids.
20. Apply **5025 psig** simultaneously to lines (17, 18, and 19) in ports P, C1, and C2. Ramp control valve handle (16) shall remain in position 2 (stop).
21. Hold pressure for **2 minutes**. Make sure external leakage is minimal with no permanent deformation of parts.
22. Remove pressure and remove pressure lines (18 and 19) from ports C1 and C2.

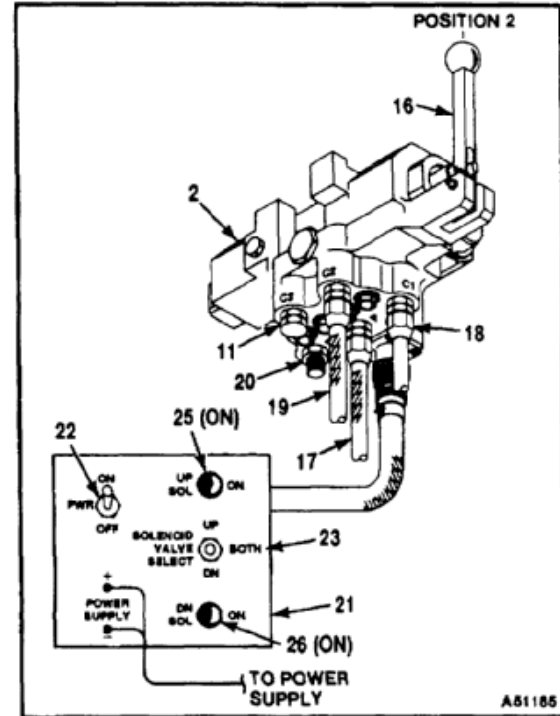
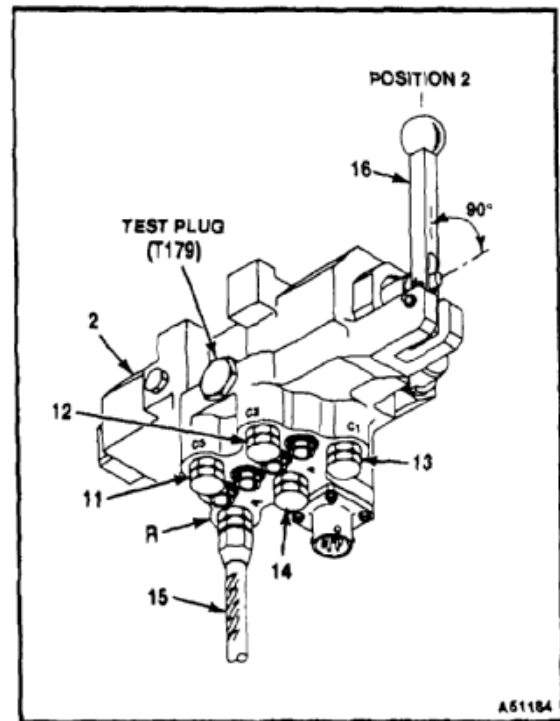

23. Set ramp control valve test set (21) (APP E-317) PWR switch (22) to OFF. UP and DN SOL lights (25 and 26) on test set shall go off.
24. Install pressure caps (12 and 13) on ports C2 and C1, and check security of pressure cap (11) on port C3. Return port R (20) shall remain open.
25. Move ramp control valve handle (16) to position 3 (up).
26. Apply **5025 psig** to pressure line (17) in pressure port P.
27. Hold pressure for **2 minutes**. Make sure external leakage is minimal and that no permanent deformation of parts occurs. Release pressure.

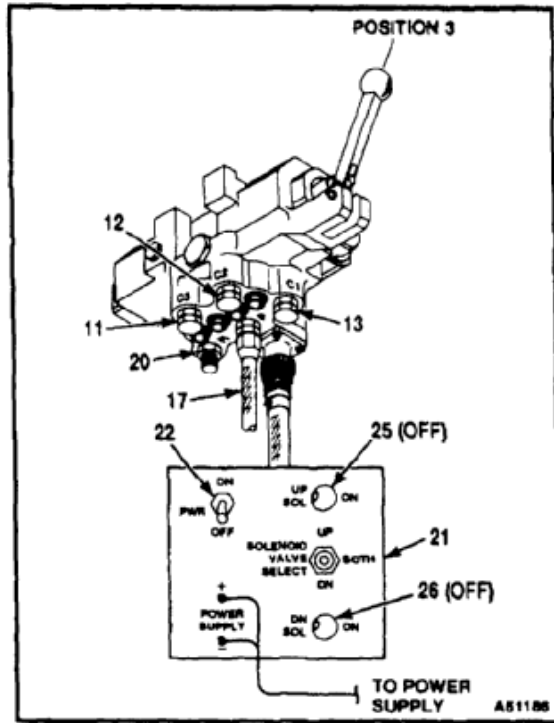

NOTE

Seals must be properly installed on thermal relief valve as described in Task 7-268.1, or ramp control valve will fail to operate properly.

28. Remove test plug (6) (T179).
29. Install new packings (3 and 4) and piston cap seal (5) on thermal relief valve (1) (Task 7-268.1).
30. Install thermal relief valve (1) in ramp control valve (2) as described in Task 7-268.1.
31. Move ramp control valve handle (16) to position 1 (down).
32. Check security of caps (11, 12, and 13) on ports C3, C2, and C1. Return port R (20) shall remain open, and test set PWR switch (22) set to OFF.
33. Apply **5025 psig** to pressure line (17) in pressure port P.
34. Hold pressure for **2 minutes**. Make sure external leakage is minimal and that no permanent deformation of parts occurs. Release pressure.

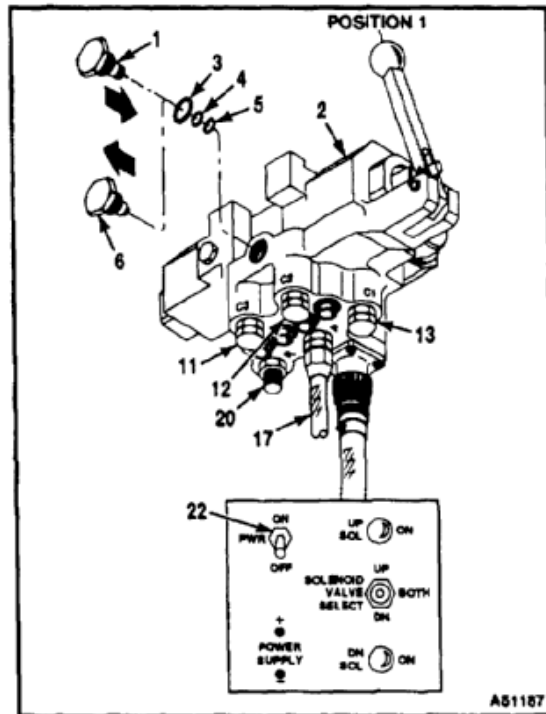

35. Prepare valve to perform functional tests as follows:
 - a. Connect two pressure gages (**0 to 4500 psig**), a hand valve, flowmeter, and system connections, to ramp control valve as shown.
 - b. Move ramp control valve handle (16) into position 3 (up).
 - c. Slowly increase pressure to ramp control valve, while simultaneously adjusting hand valve until system pressure is **3350 psig** (gage No. 1) and flow from ramp control valve is **1.5 to 1.7 gpm** (gage No. 2).
36. Move ramp control valve handle (16) from position 3 (up) to position 2 (stop).
37. Make sure PWR switch (22) on ramp control valve test set (21) (APP E-317), is set to OFF, both solenoids de-energized.
38. From position 2 (stop), make **five cycles** of the ramp control valve (2). Each cycle shall consist of manually moving ramp control valve handle (16) from position 2 (stop) to position 1 (down), to position 2 (stop), to position 3 (up), and back to position 2 (stop). There shall be no apparent binding or malfunction of ramp control valve.

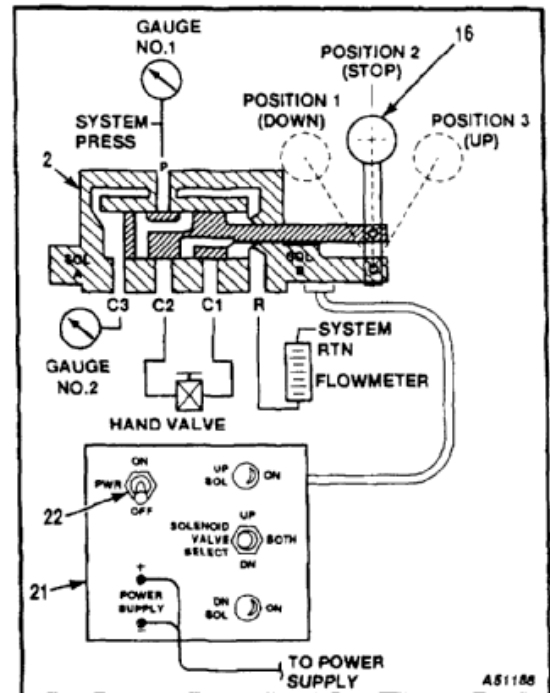

39. Configure ramp control valve as described in step 35 but with ramp control valve handle (16) set in position 2 (stop).
40. Set power supply to **18 vdc**.
41. On ramp control valve test set (21) (APP E-317), set SOLENOID VALVE SELECT switch (23) to BOTH, and PWR switch (22) to ON. Both UP and DN SOL lights (25 and 26) shall be on.
42. Operate ramp control valve through **five electrical cycles** using ramp control valve test set (21). Each cycle shall consist of steps a through d. Actuation shall be without hesitation or binding.
 - a. Set SOLENOID VALVE SELECT switch (23) to BOTH (see A). Both UP and DN SOL lights (25 and 26) of test set (21) (APP E-317) shall come on and ramp control valve handle (16) shall remain in position 2 (stop).
 - b. Set SOLENOID VALVE SELECT switch (23) to DN (see B). DN SOL light (26) shall remain on, UP SOL light (25) shall extinguish, and ramp control valve handle (16) shall move to position 1 (down).
 - c. Set SOLENOID VALVE SELECT switch (23) to BOTH (see C). Both UP and DN SOL lights (25 and 26) shall come on and ramp control valve handle (16) shall move from position 1 to position 2 (stop).
 - d. Set SOLENOID VALVE SELECT switch (23) to UP (see D). UP SOL light (25) shall come on, DN SOL light (26) shall extinguish, and ramp control valve handle (16) shall move to position 3 (up). Return to step a for beginning of next cycle.
43. Repeat step 42 while increasing voltage to **30 vdc**. Valve shall operate without binding.
44. Remove hydraulic pressure from ramp control valve (2), and set ramp control valve test set PWR switch (22) to OFF.

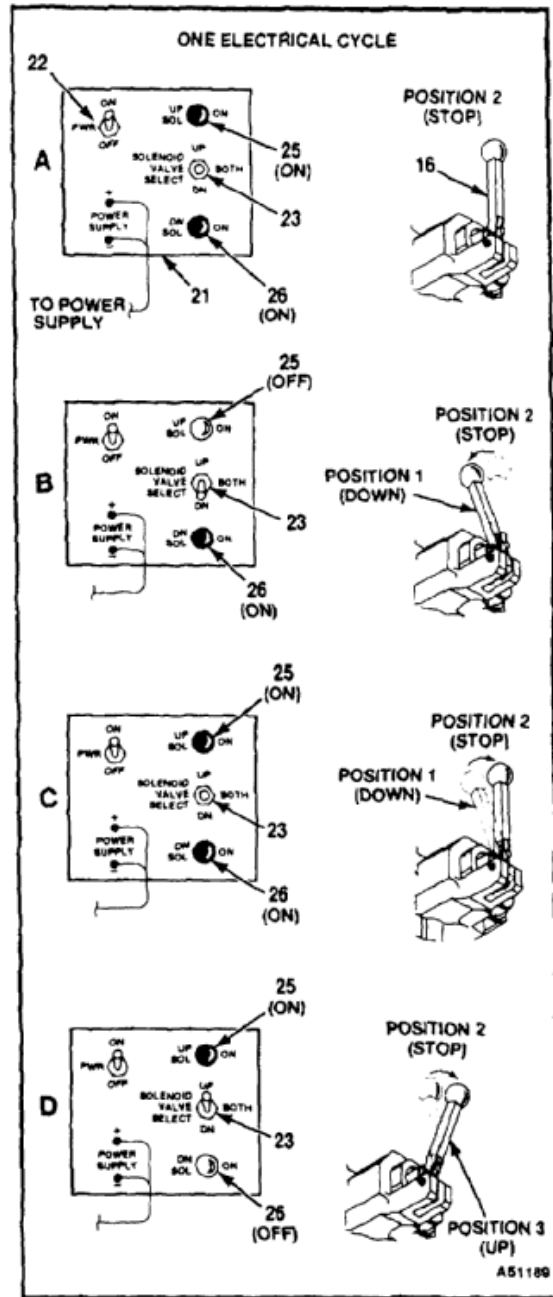

NOTE

The following tests must be made with hydraulic fluid (E199) at **80° to 120°F**.

45. Perform internal leakage checks as follows. Allow **2 minutes** following each pressure application before leakage rate is measured.

a. Check internal leakage with ramp control valve handle (16) in position 2 (stop) as follows:

- (1) Install pressure caps (13, 12, and 11) on ports C1, C2, and C3.
- (2) Connect pressure line (17) to pressure port P. Leave return port R (20) open.
- (3) Set power supply to **28 vdc**, ramp control valve test set PWR switch (22) to ON, and SOLENOID VALVE SELECT switch (23) to BOTH. Both UP and DN SOL lights (25 and 26) shall come on.
- (4) Apply **3350 psig** to pressure line (17) in pressure port P. Handle (16) shall remain in position 2. Leakage from return port R (20) shall not exceed **10 dpm**.

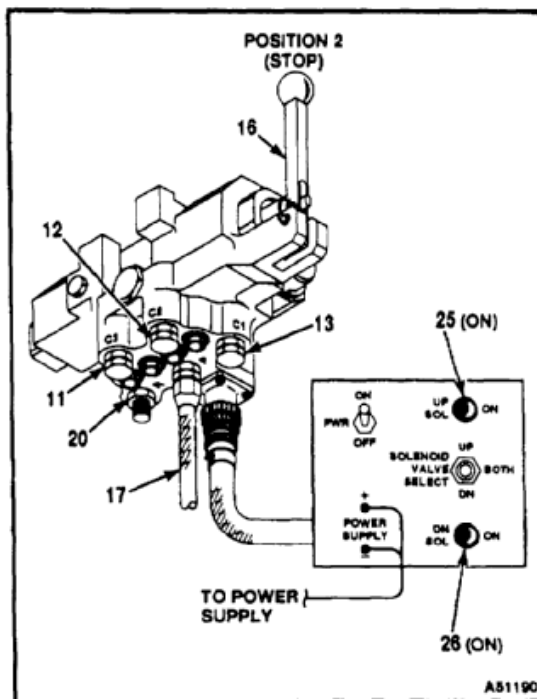

- (5) Remove pressure from ramp control valve (2), and remove caps from ports C1 (28) and C2 (29). Cap (11) shall remain on port C3.
- (6) Set ramp control valve test set PWR switch (22) to OFF. UP and DN SOL lights (25 and 26) shall go off.
- (7) Apply **3350 psig** to pressure line (17) in pressure port P. Leakage from ports C1 (28) and C2 (29) shall not exceed **1 dpm**.

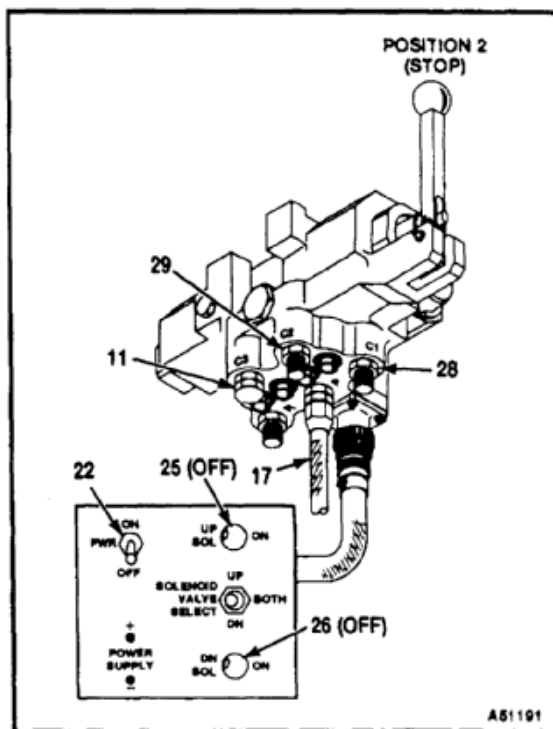

b. Check internal leakage of ramp control valve, with handle (16) in position 1 (down) as follows:

- (1) Install pressure caps (13, 12, and 11) on ports C1, C2, and C3, and connect pressure supply line (17) to pressure port P. Keep return port R (20) open.
- (2) Set ramp control valve test set PWR switch (22) to ON, and SOLENOID VALVE SELECT switch (23) to DN. DN SOL light (26) on test box shall come on.
- (3) Apply **3350 psig** to pressure line (17) in pressure port P. Ramp control valve handle (16) shall move into position 1. Leakage from return port R (20) shall not exceed **10 dpm**.
- (4) Keep ramp control valve handle (16) in position 1 and set PWR switch (22) to OFF. Leakage from return port R (20) shall not exceed **10 dpm**.

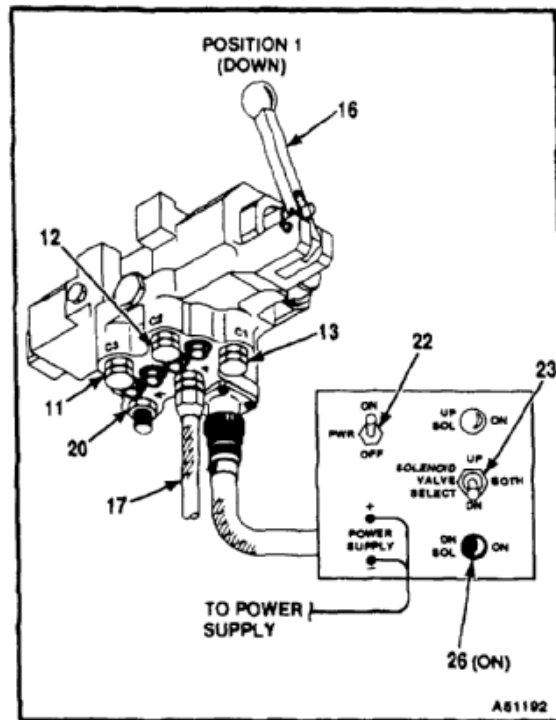

c. Continuing from last test, check internal leakage of ramp control valve with handle (16) in position 3 (up) as follows:

- (1) Set ramp control valve test set PWR switch (22) to ON, and SOLENOID VALVE SELECT switch (23) to UP. UP SOL light (25) on test set shall come on. Ramp control valve handle (16) shall move into position 3. Leakage from return port R (20) shall not exceed **10 dpm**.
- (2) Keep ramp control valve handle (16) in position 3 and set PWR switch (22) to OFF. UP SOL light (25) shall go off. Leakage from return port R (20) shall not exceed **10 dpm**.

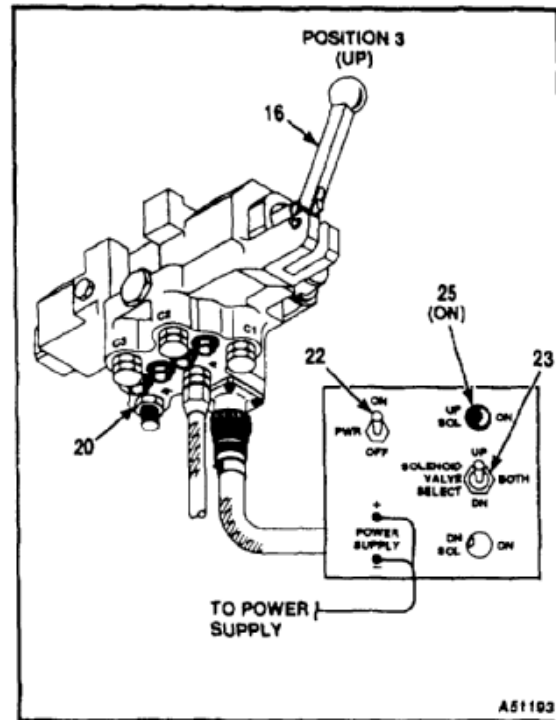

- d. Remove pressure from ramp control valve (2).
- e. Set PWR switch (22) to OFF.
- f. Move ramp control valve handle (16) to position 2 (stop).
- g. Check internal leakage of ramp control valve, with handle (16) in position 2 (stop) as follows:
 - (1) Remove cap from port C1 (28) and pressure line from pressure port P (24).
 - (2) Install pressure cap (14) over pressure port P (24) and connect pressure line (8) to port C1. Caps (11 and 12) shall remain on ports C3 and C2, and return port R (20) shall remain open.
 - (3) Apply **3350 psig** to pressure line (8) in port C1, and check leakage from return port R (20). Leakage rate shall not exceed **1 dpm**.

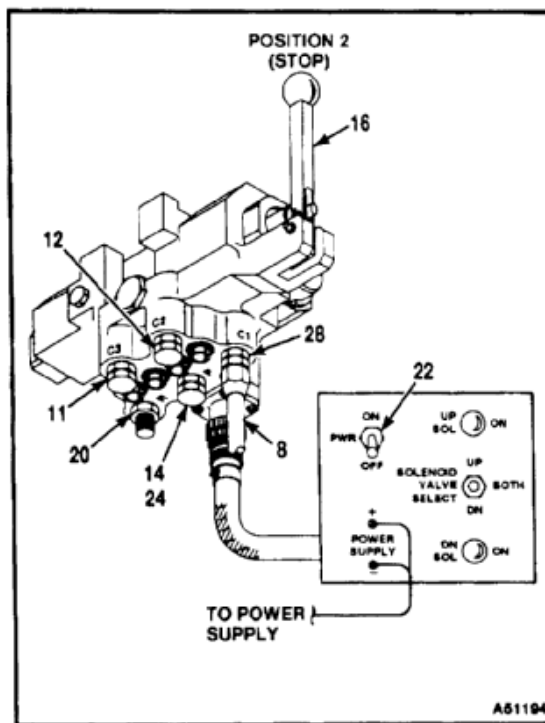

- (4) Remove pressure from ramp control valve (2).
- (5) Remove pressure cap from port C2 and install pressure line (19).
- (6) Install pressure cap (13) on port C1.
- (7) Apply **3350 psig** to port C2, and check leakage from return port R (20). Leakage rate shall not exceed **1 dpm**.

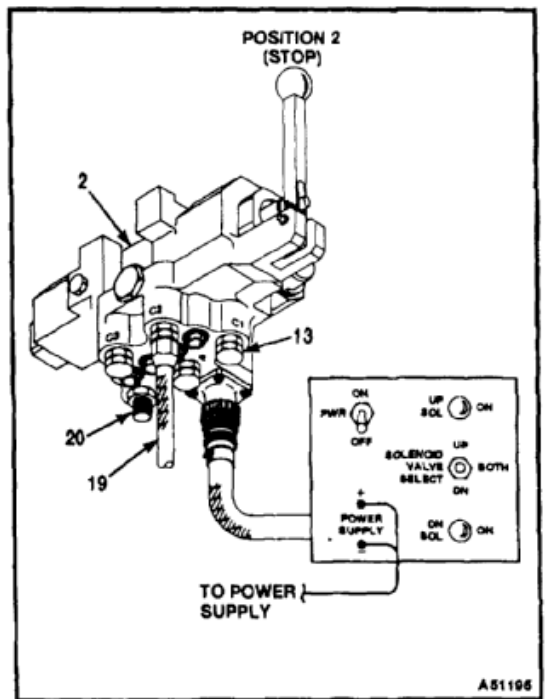

46. Configure and test ramp control valve to determine manual operating forces, as follows:
- Remove all pressure and electrical power from ramp control valve (2).
 - Remove pressure line from port C2 and install pressure cap (12). Caps (11 and 13) shall remain on ports C3 and C1.
 - Connect separate pressure lines (17 and 25) to pressure port P, and return port R.
 - Install ramp control valve in fixture (30).
 - Apply **3000 psig** to pressure line (17) in pressure port P and **80 psig** to pressure line (25) in return port R.
 - Place ramp control valve handle (16) in position 2 (stop).
 - Use a spring scale to apply a steadily increasing force perpendicular to ramp control valve handle (16) until handle moves to position 3 (up). Force required to actuate handle shall be **5 to 20 pounds** without apparent binding or malfunction.
 - Repeat previous step, moving handle (16) from position 2 (stop) to position 1 (down).

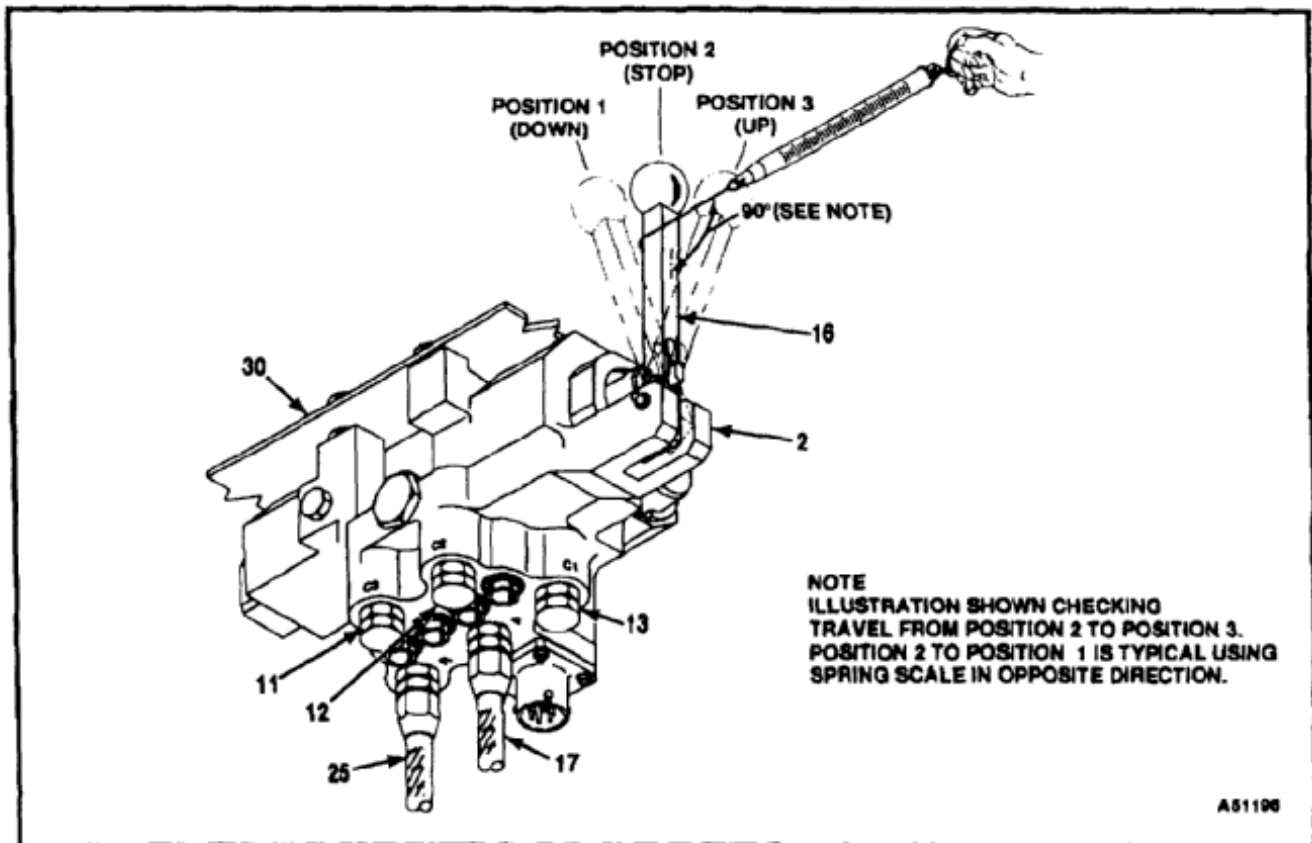
**FOLLOW-ON MAINTENANCE:**

None

END OF TASK

7-1008

INITIAL SETUP

Applicable Configurations:

All

Tools:

Aircraft Mechanic's Tool Kit, NSN 51 80-00-323-4692

Materials:

None

Parts:

Preformed Packings
Nonmetallic Washers

Personnel Required:

Medium Helicopter Repairer
Inspector

References:

TM 55-1520-240-23P

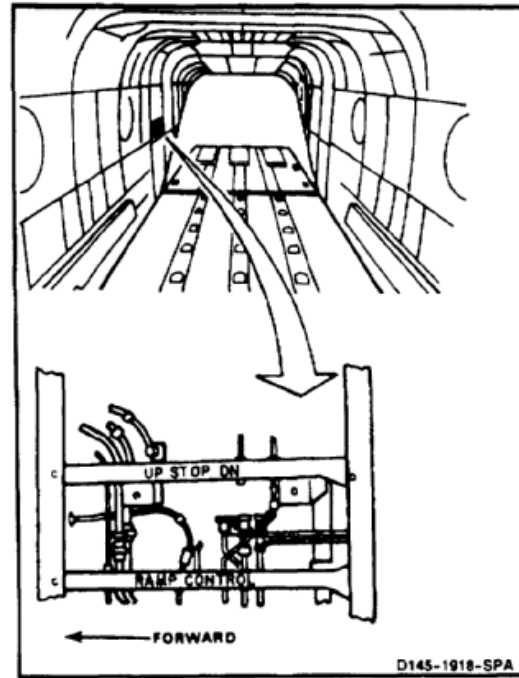

NOTE

Some illustrations that follow, show only a typical valve without **65** for descriptive purposes only. Where more information is necessary, bottom views are provided for both valves with and without **65**, even though the primary view reflects only the one configuration.

1. Install two nuts (1) on tees (2).
- 1.1 Install two packings (3), washers (3.1), and tees (2) in ports P and R. Point fittings as shown, and tighten nuts (1).

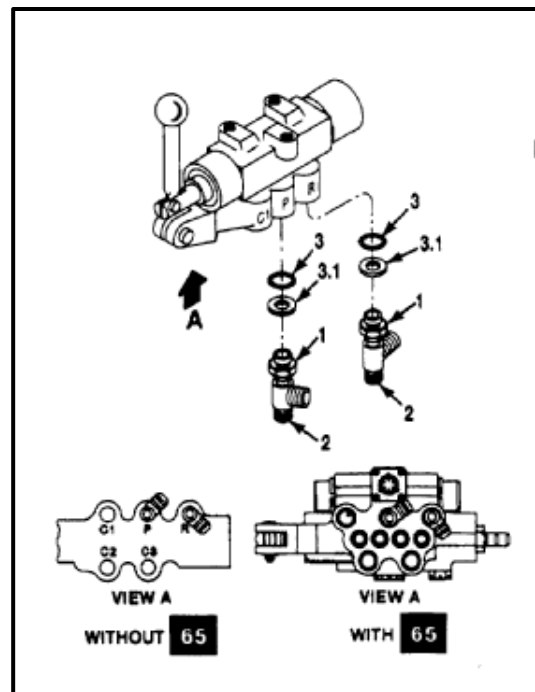

2. Install three packings (4) and nipples (5) in ports C1, C2, and C3.

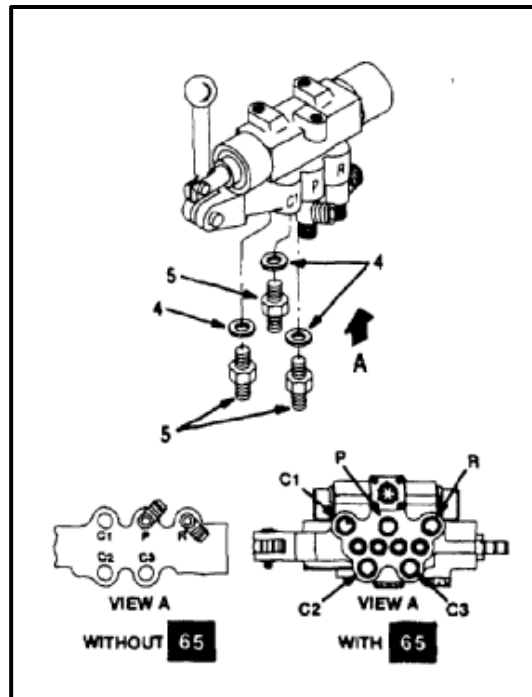

3. Position valve (6) as shown. Install three spacers (7), washers (8), and bolts (9) loosely.

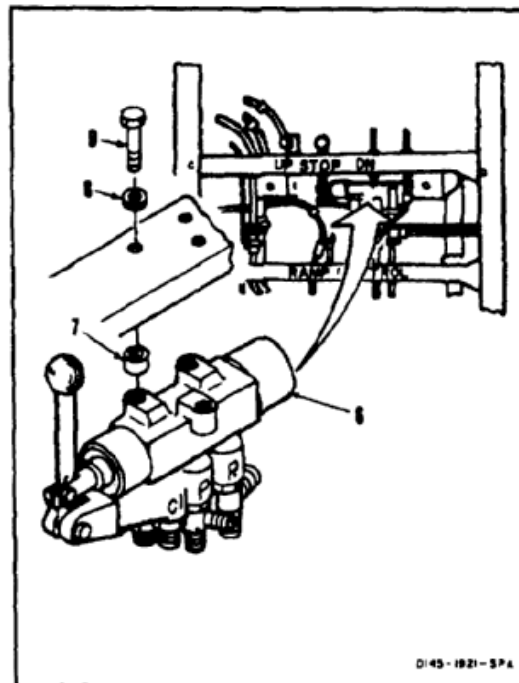

NOTE

Tubing shown under valve without **65** same tubing to be connected to valve with **65**. For ease of display, call-outs have been left off tubing under valve with **65**.

4. Connect seven hydraulic tubes (10). Remove tags.
5. Tighten bolts (9).
6. Tighten two nuts (11).
7. On valve with **65**, install connector (12).

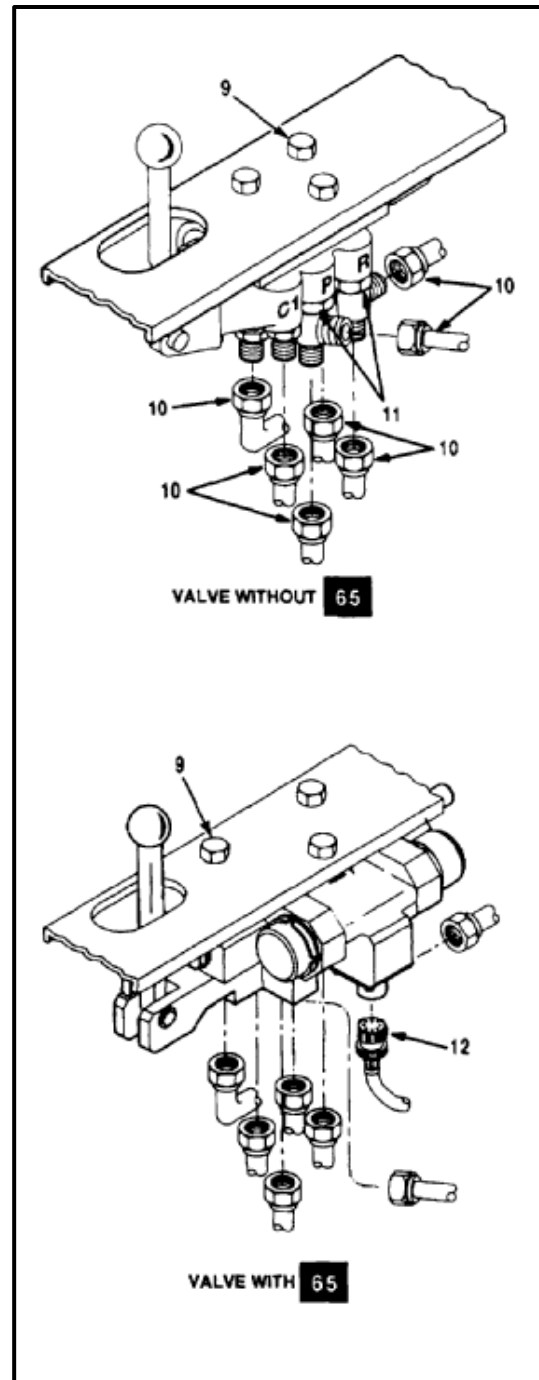
INSPECT**FOLLOW-ON MAINTENANCE:**

Bleed cargo ramp hydraulic system (Task 7-339).
Perform operational check of ramp control valve (TM 55-1520-240-T).

END OF TASK

INITIAL SETUP

Applicable Configurations:

All

Tools:

Aircraft Mechanic's Tool Kit, NSN 5180-00-323-4692
 Container, 2 Quart

Materials:

Cloths (E135)
 Paper Tags (E264)
 Gloves (E186)

Personnel Required:

Medium Helicopter Repairer (2)

Equipment Condition:

Battery Disconnected (Task 1-39)
 Electrical Power Off
 Hydraulic Power Off
 Cargo Ramp Fully Down (TM 55-1520-240-T)
 Utility Hydraulic System Depressurized (Task 7-135.1)

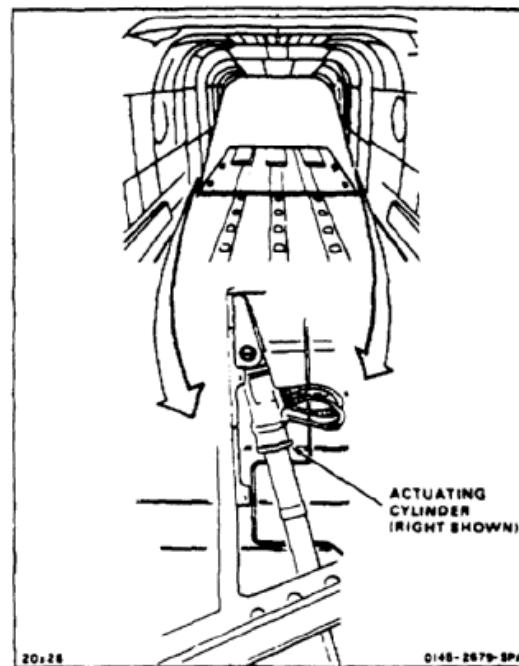
**General Safety Instructions:****WARNING**

Hydraulic fluid (E199) is toxic. It can irritate skin and cause burns. Avoid inhaling. Use only with adequate ventilation. Avoid contact with skin, eyes, or clothing. In case of contact, immediately flush skin or eyes with water for at least **15 minutes**. Get medical attention for eyes.

WARNING

Hydraulic fluid ejected under pressure can cause injury to personnel. Hydraulic fluid sprayed into the air is a fire hazard.

NOTE

Procedure is same to remove left or right ramp actuating cylinders. Right cylinder is shown here.

1. Remove bolt (1), washer (2), and packing (3) from ramp (4) at lower end of actuating cylinder (5).
2. Tag and disconnect three hoses (6) from cylinder (5). Use container and cloths (E135) for spilled fluid. Use gloves (E186).
3. Tag cylinder (5). Have helper hold cylinder (5). Remove nut (7), two washers (8), and bolt (9) from fitting (10). Depress and remove cylinder.
4. Remove three nipples (11) and packings (12) from cylinder (5).

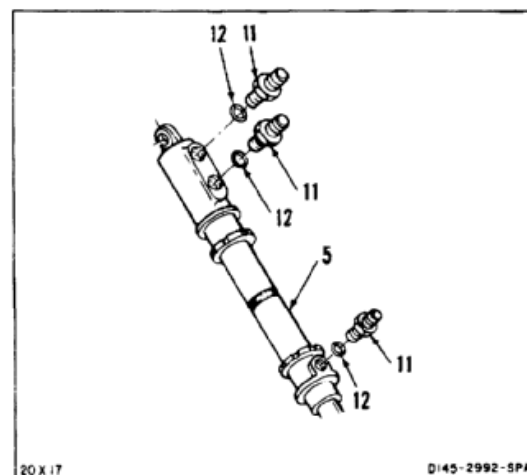
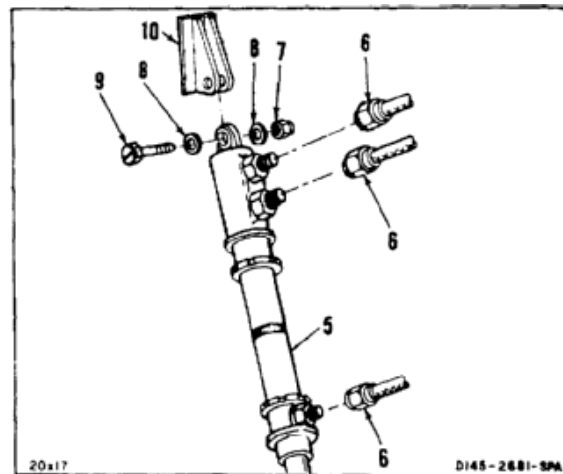
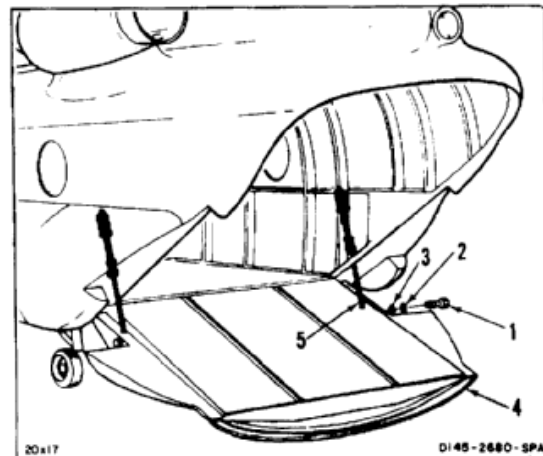
**FOLLOW-ON MAINTENANCE:**

None

END OF TASK

INITIAL SETUP

Application Configurations:

All

Tools:

Hydraulic Repairer's Tool Kit, NSN 5180-00-323-4891
 Torque Wrench, 700 to 1600 Inch-Pounds
 Arbor Press
 Staking Die (2)
 Crowfoot Wrench, 1 Inch
 Open End Wrench, 1 Inch

Materials:

Castor Oil (E93) or Grease (E189)
 Lockwire (E231)

Parts:

Bearing
 Rod End Bearing

Personnel Required:

Aircraft Pnedraulics Repairer
 Inspector

References:

TM 55-1500-322-24
 TM 55-1520-240-23P

Equipment Condition:

Off Helicopter Task

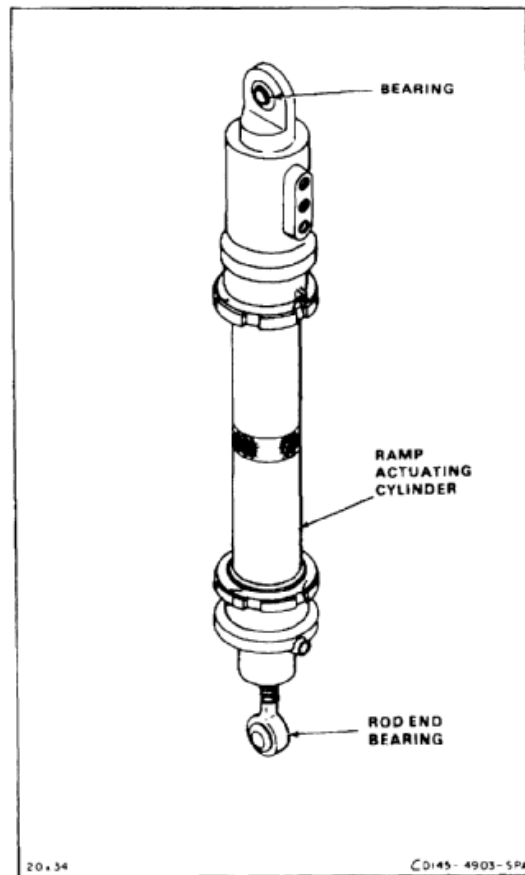
**REPLACE BEARING**

1. Install cylinder (1) in arbor press as shown.
2. Remove bearing (2) from bushing (3) (TM 55-1500-322-24).

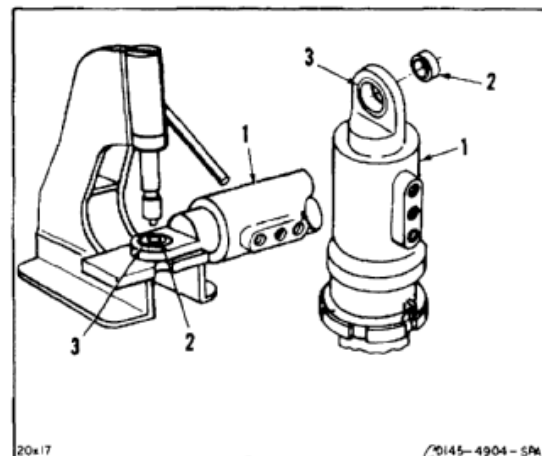

CAUTION

Liner of bearing must be kept free of grease and oil. Grease or oil on liner can result in damage to bearing.

3. Coat mating surfaces of new bearing (2) and bushing (3) with grease (E189) or castor oil (E93).
4. Position bearing (2) in bushing (3). Press bearing into bushing (3) (TM 55-1500-322-24).
5. Position staking dies (4) on both sides of bearing (2) so that six restaking indents in bushing (3) will be equally spaced between six original indents in bushing. If restaking of bearing will result in more than 12 indents in bushing, replace bushing.
6. Stake bushing (3) on both sides at same time, to depth of **0.020 inch** (TM 55-1500-322-24).
7. Remove cylinder (1) from arbor press.
8. Check bearing (2) for binding (TM 55-1500-322-24).

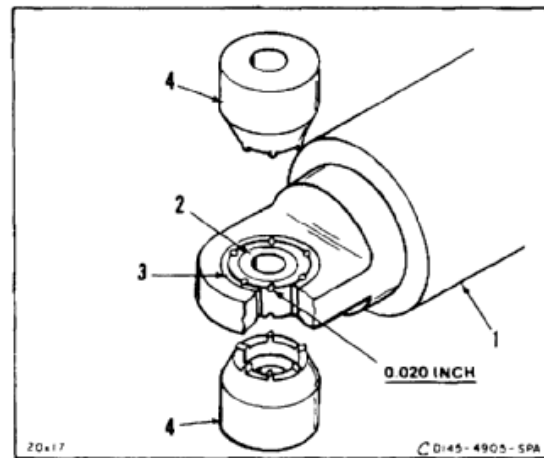

REPLACE ROD END BEARING

9. Remove lockwire from nut (5).
10. Measure and record dimension A, between end of piston (6) and center of rod end bearing (7).

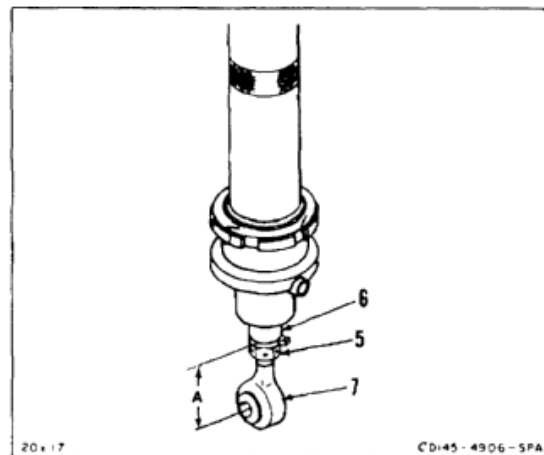

11. Loosen nut (5) and remove bearing (7) from piston (6).
12. Remove washer (8) and nut (5) from bearing (7).

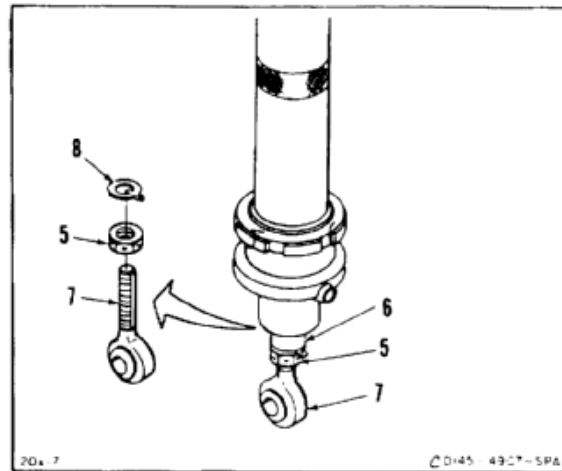

13. Install nut (5) and washer (8) on new bearing (7).
14. Install bearing (7) in piston (6), to dimension A, recorded in step 10.
15. Make sure tab of washer (8) fits into groove in piston (6). Tighten nut (5) and washer against piston.
16. Hold bearing (7) and torque nut (5) to **1200 inch-pounds**.
17. Lockwire nut (5) to washer (8). Use lockwire (E231).

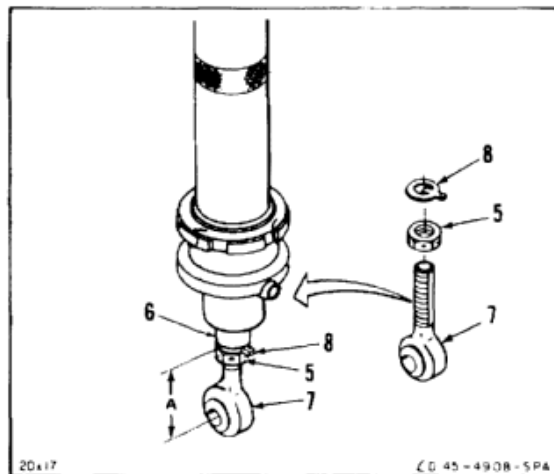
**FOLLOW-ON MAINTENANCE:**

None

END OF TASK

7-1016

7-273 INSTALL CARGO RAMP ACTUATING CYLINDER

7-273

INITIAL SETUP

Applicable Configurations:

All

Tools:

Aircraft Mechanic's Tool Kit, NSN 5180-00-323-4692
Torque Wrench, 700 to 1600 Inch-Pounds

Materials:

Lockwire (E231)

Parts:

Nuts
Preformed Packings

Personnel Required:

Medium Helicopter Repairer (2)
Inspector

References:

TM 55-1520-240-23P

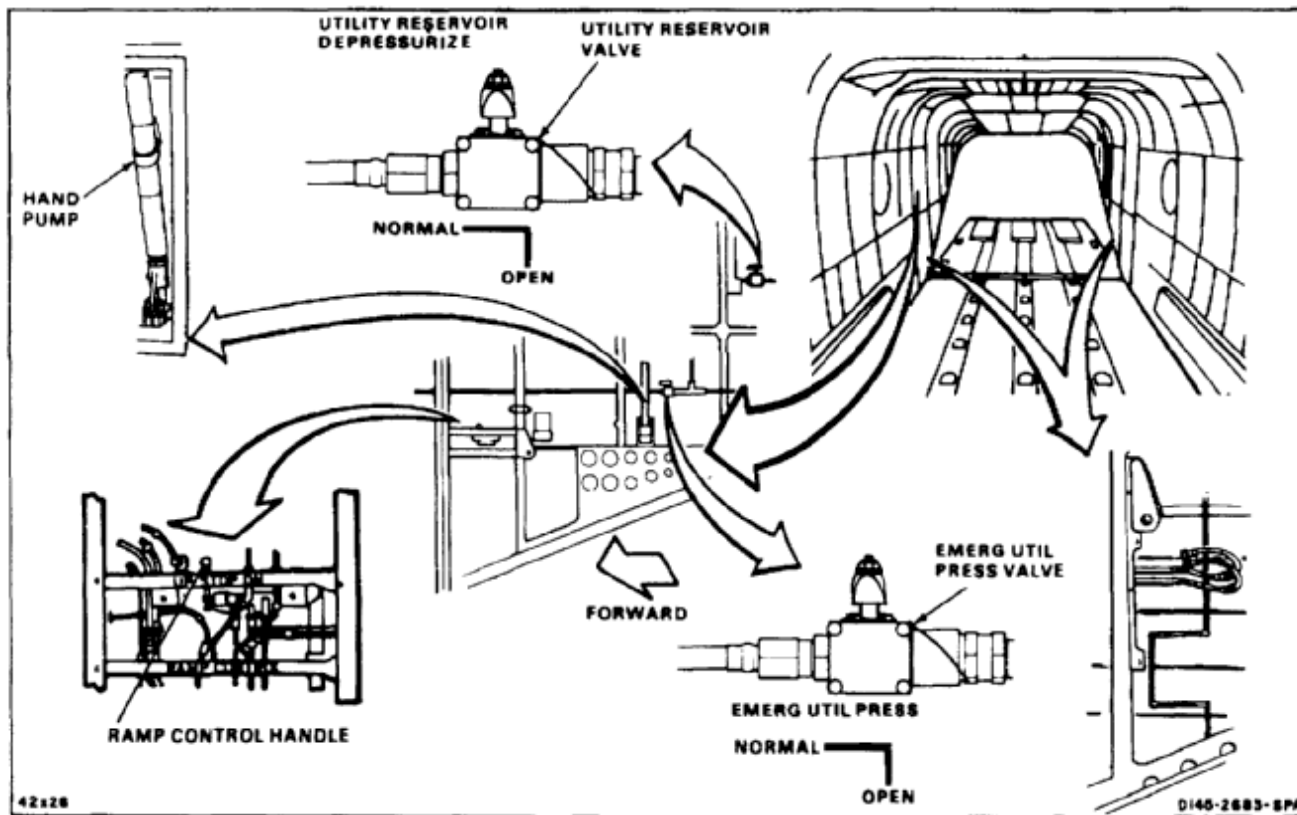

NOTE

Procedure is same to install left or right ramp actuating cylinders. Right cylinder shown here.

1. Install three packings (1) and nipples (2) in cylinder (3).

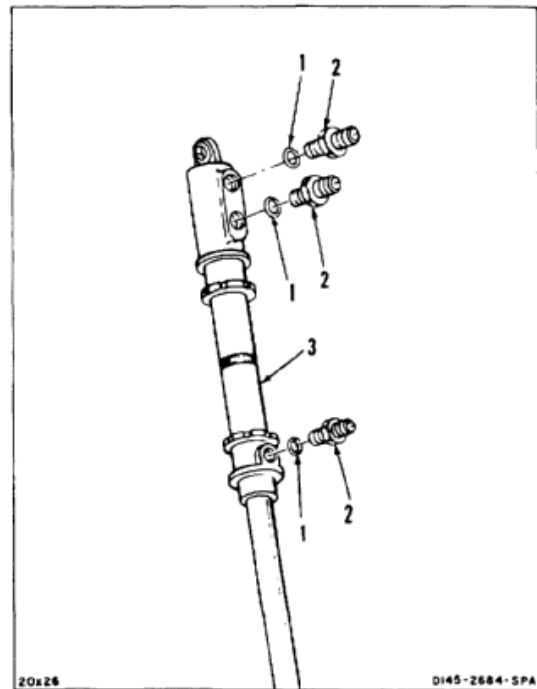

2. Position cylinder (3) in upper fitting (4). Make sure ports (5, 6, and 7) face aft.
3. Install bolt (8), head inboard, washers (9 and 10), and nut (11).
4. Connect hose (12) to ramp down port (5). Remove tag.
5. Connect hose (13) to return port (6). Remove tag.
6. Connect hose (14) to ramp up port (7). Remove tag.

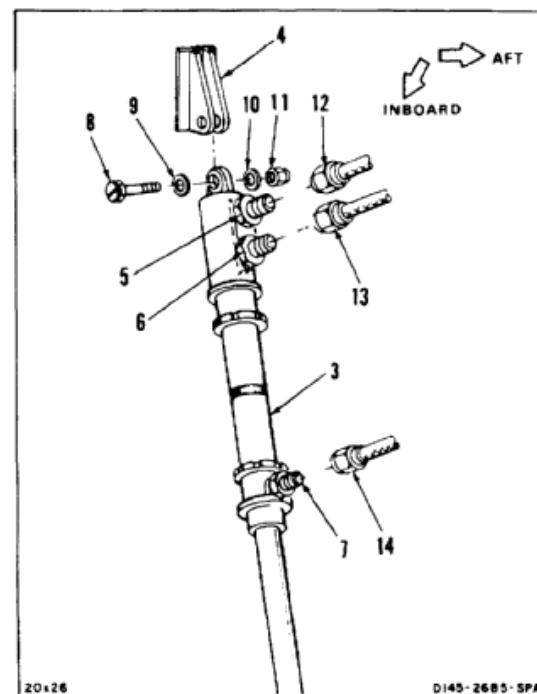

7. Set ramp control handle (15) to DN.

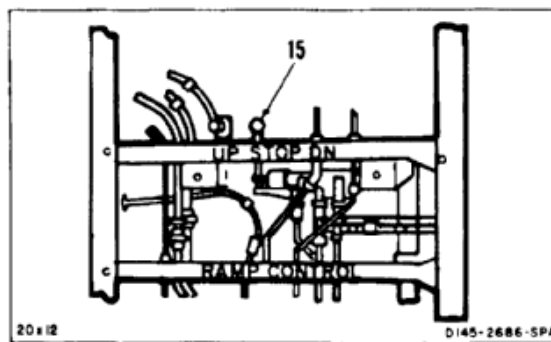

8. Set EMERG UTIL PRESS valve (16) to NORMAL.

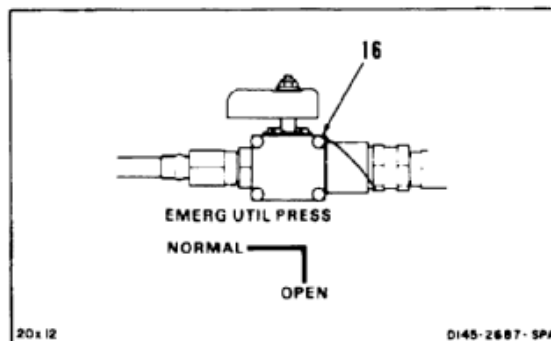

9. Set UTILITY RESERVOIR valve (17) to NORMAL.

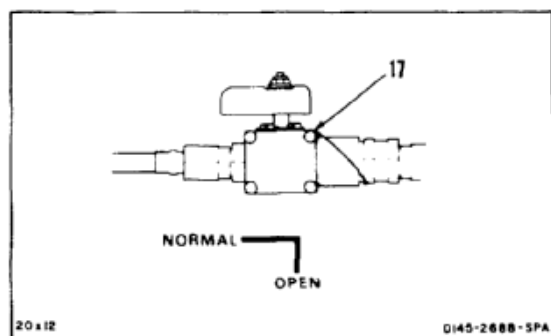

10. Operate hand pump (18) to extend cylinder (3). If more length is required, remove lockwire and loosen nut (19) at lower end of cylinder (3). Turn rod end (20). Do not tighten nut.

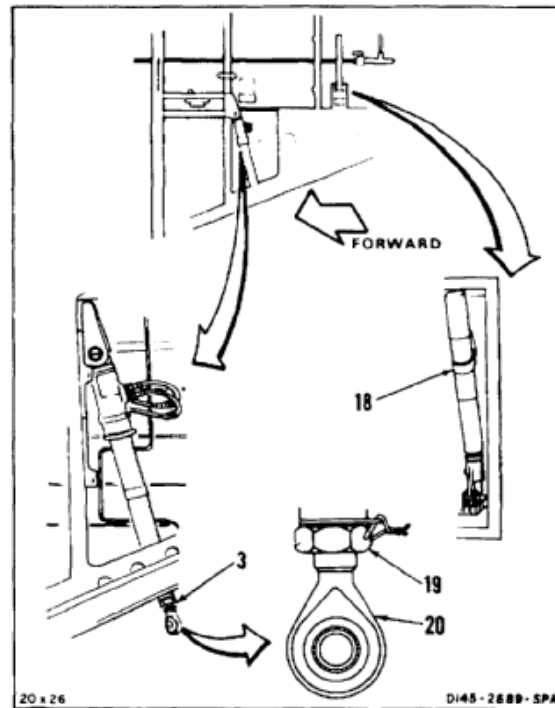

11. Position lower end of cylinder (3) in ramp slot (21) of ramp (4).
12. Install packing (22), washer (23), and bolt (24) in ramp (4). Adjust rod end (20) to align with bolt.

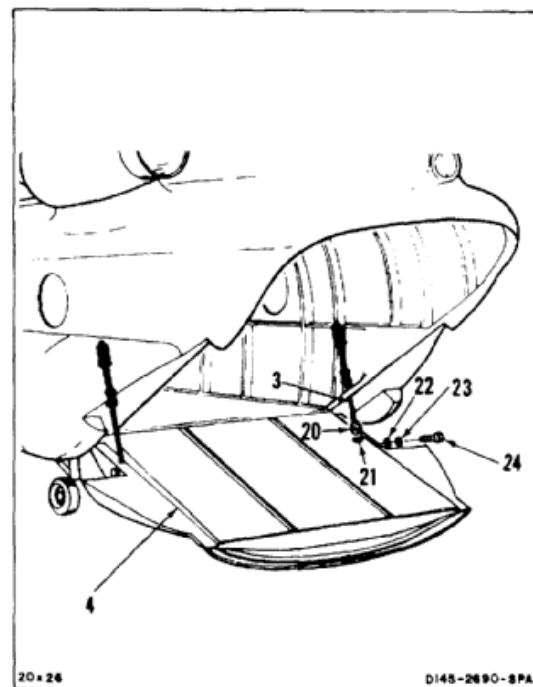

7-273 INSTALL CARGO RAMP ACTUATING CYLINDER (Continued)

7-273

13. Torque nut (19) to **1200 inch-pounds**. Lockwire nut to washer (25). Use lockwire (E231). Remove tag from cylinder (3).

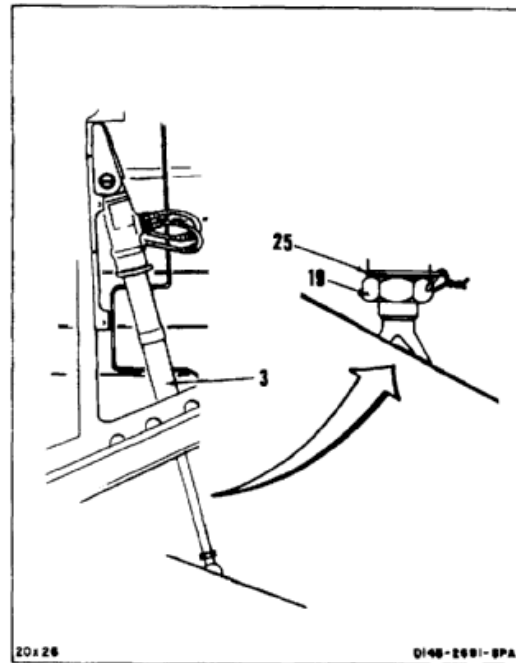
INSPECT**FOLLOW-ON MAINTENANCE:**

- Bleed ramp control system (Task 7-339).
- Adjust ramp (Task 7-274).
- Perform operational check (TM 55-1520-240-T).

END OF TASK

INITIAL SETUP

Applicable Configurations:

All

Tools:

Aircraft Mechanic's Tool Kit, NSN 5180-00-323-4692
Torque Wrench, 700 to 1600 Inch-Pounds

Materials:

Lockwire (E231)

Personnel Required:

Medium Helicopter Repairer
Inspector

Equipment Condition:

Battery Connected (Task 1-39)
Electrical Power On
Hydraulic Power On
Cargo Ramp Fully Down (TM 55-1520-240-T)
Utility Hydraulic System Pressurized (TM 55-1520-240-T)

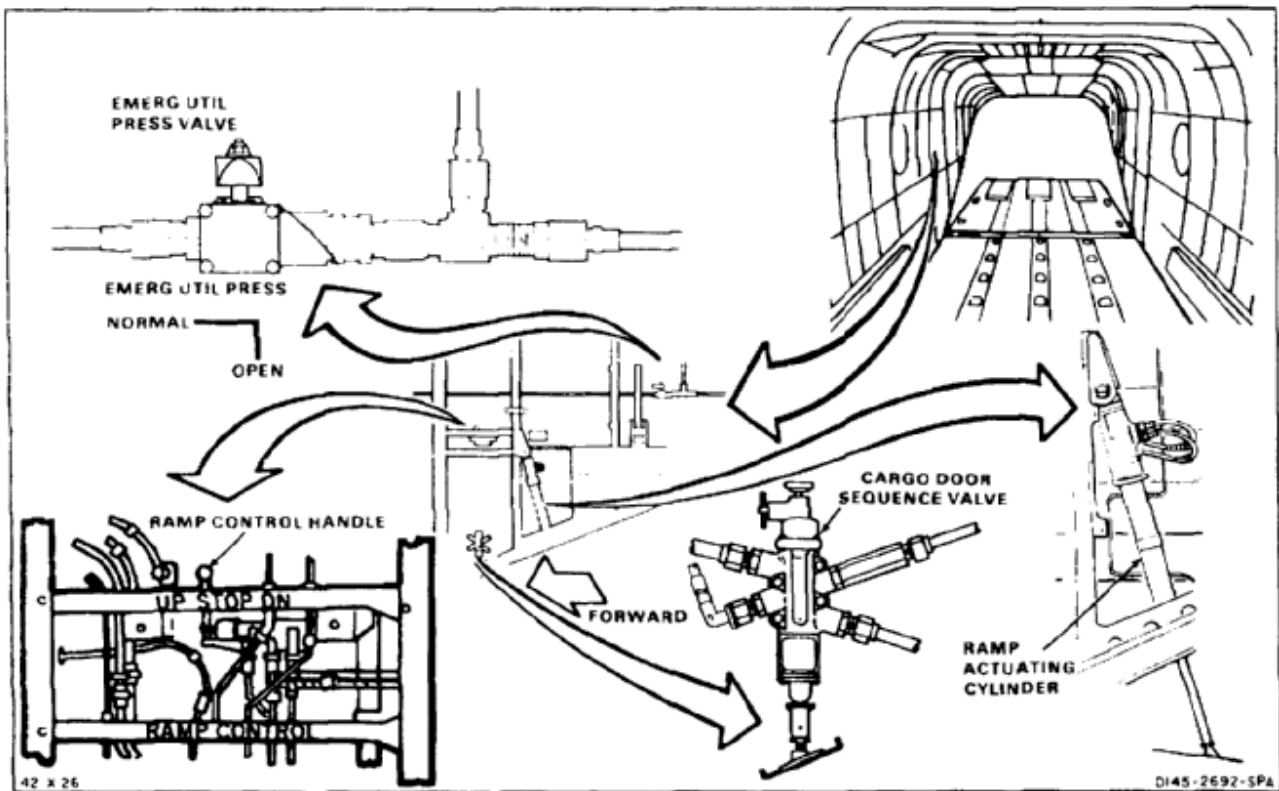

1. Set EMERG UTIL PRESS valve (1) to NORMAL.

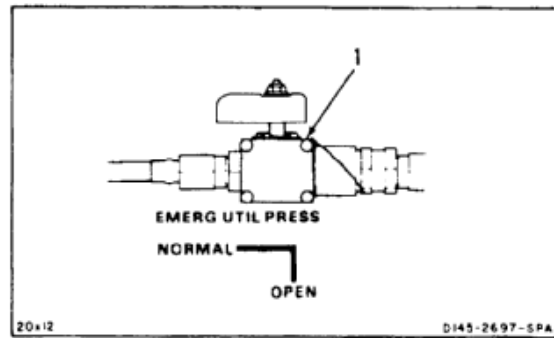

2. Press and hold MANUAL OPER knob (2) on sequence valve (3). Turn pin (4) 90° in either direction. Release knob.

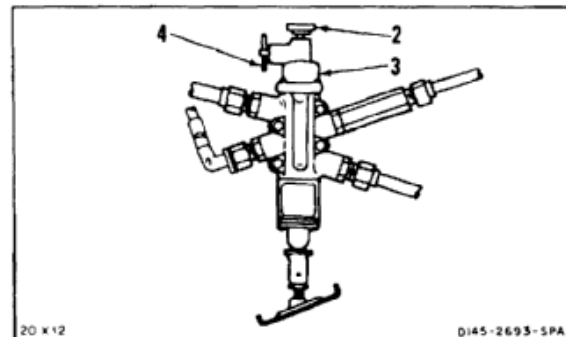

3. Set ramp control handle (5) to UP. Raise ramp to within **12 inches** approx. of fully closed position. Set handle to STOP.
4. Set handle (5) to UP and back to STOP. Repeat this procedure until ramp does not move.

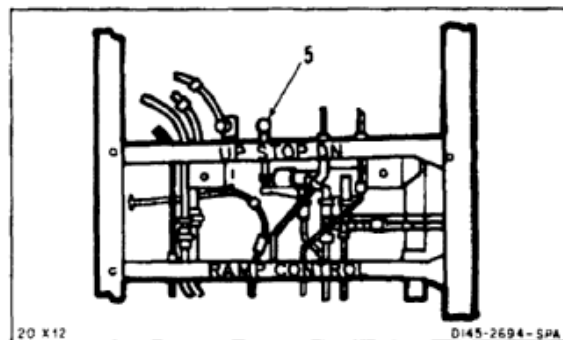

5. Check that sealing strip (6) is evenly compressed about **0.1 inch** against ramp (7) on both sides of ramp. If sealing strip is not compressed on one or both sides go to step 6. If sealing strip is compressed too much on one or both sides go to step 13.

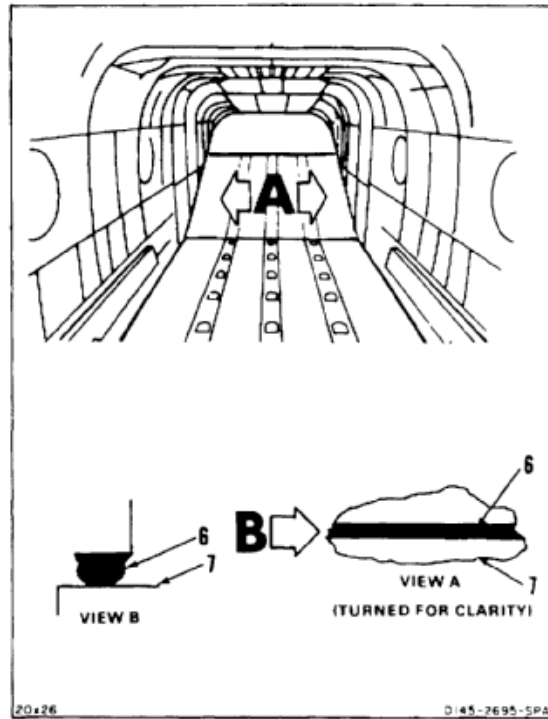

SEALING STRIP IS NOT COMPRESSED ON ONE OR BOTH SIDES

6. Set ramp control handle (5) to DN. Position ramp fully down.
7. Set ramp control handle (5) to STOP.

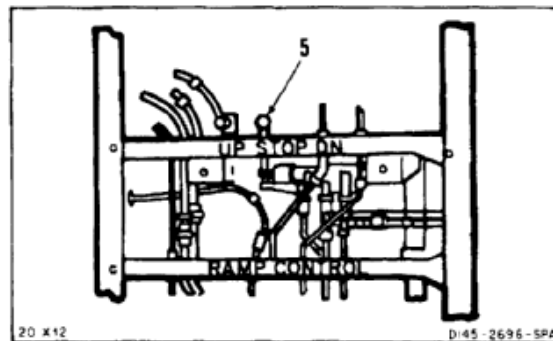

8. Remove lockwire and loosen nut (8) on left or right cylinder to be adjusted. Right shown.

NOTE

One turn moves ramp about **0.08 inch**.

9. Turn cylinder (9) clockwise. Use wrench on flats (10).
 10. Repeat steps 2, 3 thru 5. Then go to step 11.
 11. Torque nut (8) to **1200 inch-pounds**.
 12. Lockwire nut (8) to washer (11). Use lockwire (E231).

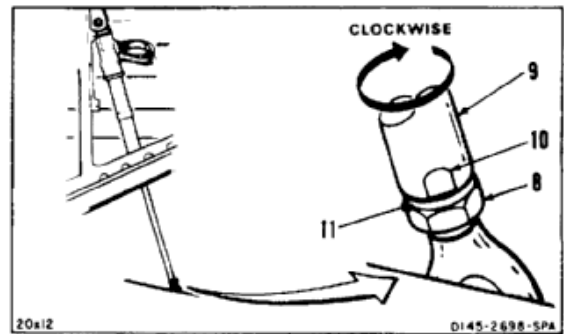
**SEALING STRIP IS COMPRESSED TOO MUCH ON ONE OR BOTH SIDES**

13. Perform steps 6 thru 8. Then go to step 14.
 14. Turn cylinder (9) counterclockwise. Use wrench on flats (10).

NOTE

One turn moves ramp about **0.08 inch**.

15. Repeat steps 2, 3 thru 4. Then go to step 16.
 16. Torque nut (8) to **1200 inch-pounds**.
 17. Lockwire nut (8) to washer (11). Use lockwire (E231).

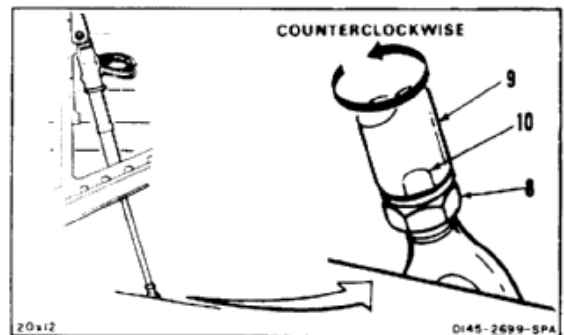
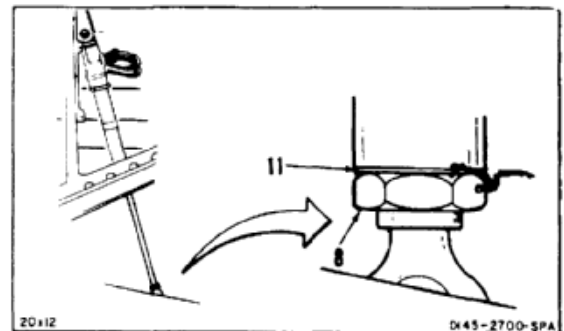
**INSPECT****FOLLOW-ON MAINTENANCE:**

Perform operational check (TM 55-1520-240-T).

END OF TASK

INITIAL SETUP

Applicable Configurations:

All

Tools:

Aircraft Mechanic's Tool Kit, NSN 5180-00-323-4692

Materials:

Cloth (E135)
 Paper Tags (E264)
 Gloves (E186)

Personnel Required:

Medium Helicopter Repairer

Equipment Condition:

Battery Disconnected (Task 1-39)
 Electrical Power Off
 Hydraulic Power Off
 Cargo Ramp Fully Down (TM 55-1520-240-T)
 Utility Hydraulic System Depressurized (Task 7-135.1)

General Safety Instructions:**WARNING**

Hydraulic fluid (E199) is toxic. It can irritate skin and cause burns. Avoid inhaling. Use only with adequate ventilation. Avoid contact with skin, eyes, or clothing. In case of contact, immediately flush skin or eyes with water for at least **15 minutes**. Get medical attention for eyes.

WARNING

Hydraulic fluid ejected under pressure can cause injury to personnel. Hydraulic fluid sprayed into the air is a fire hazard.

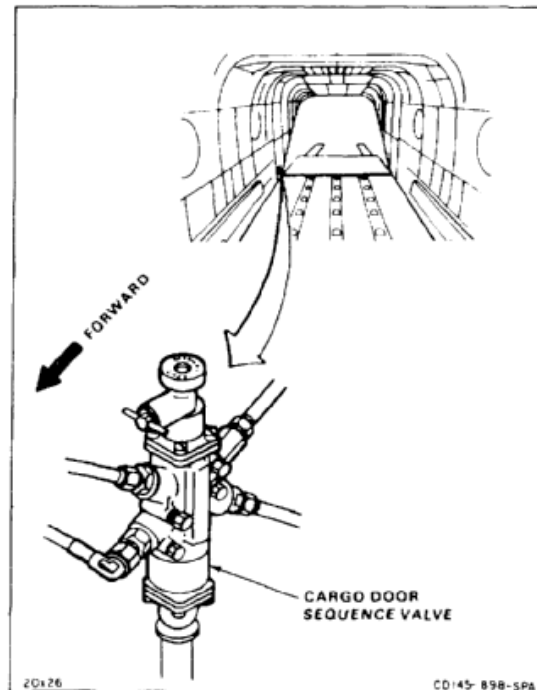

7-275 REMOVE CARGO DOOR SEQUENCE VALVE (Continued)

7-275

1. Tag and disconnect four hydraulic tubes (1) from valve (2). Use cloth (E135) for spilled fluid. Use gloves (E186).

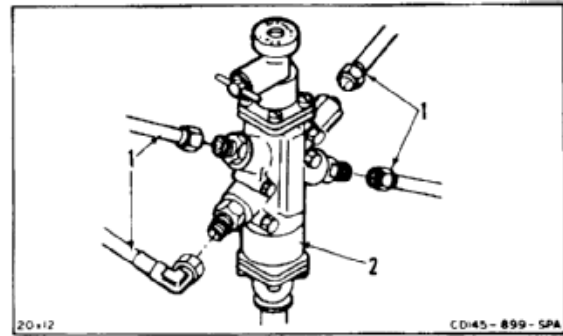

2. Remove four bolts (3) and washers (4). Remove valve (2).

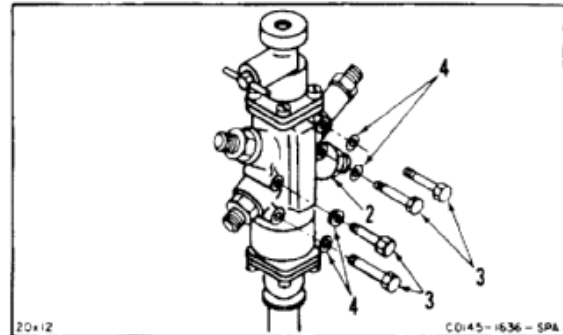

3. Remove restrictor (5) and packing (6).
4. Remove four nipples (7) and packings (8).

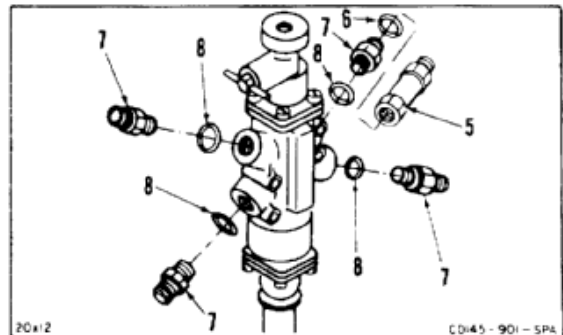
**FOLLOW-ON MAINTENANCE:**

None

END OF TASK

7-1027

INITIAL SETUP

Applicable Configurations:

All

Tools:

- Hydraulic Repairer's Tool Kit, NSN 5180-00-323-4891
- Brass Drift, 6 Inches X 1/2 Inch
- Soft Jawed Vise
- Cotter Pin Extractor

Materials:

None

Personnel Required:

Aircraft Pneudraulics

Equipment Condition:

Off Helicopter Task

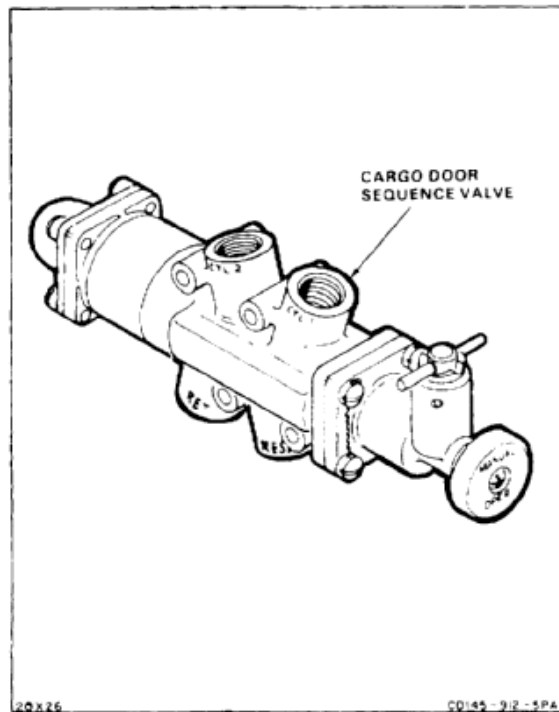

1. Remove lockwire, four screws (1) and retainer (2) from body (3).

NOTE

Do not take cartridge apart.

2. Remove cartridge (4) from body (3).

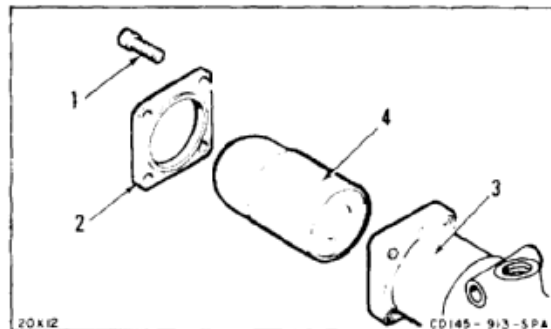

3. Remove screw (5) and knob (6).
4. Remove pin (7) from cap (8). Use cotter pin extractor (9).
5. Remove stem (10) from cap (8).
6. Remove pin (11), sleeve (12), and spring (13) from stem (10).

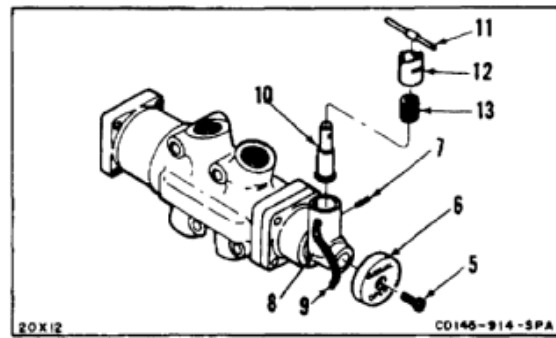

7. Remove lockwire, four screws (14) and cap (8).
8. Remove spring (15) and guide (16) from body (3).

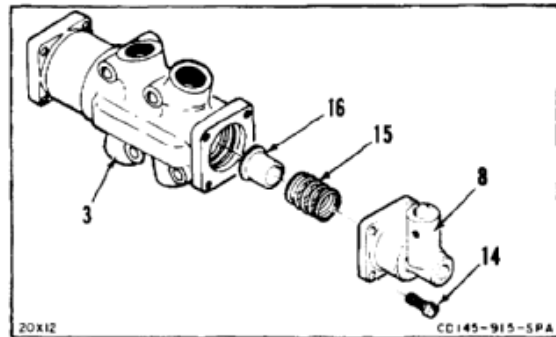

9. Clamp body (3) in vise (17).

CAUTION

Keep spool and sleeve together as matched selector set. Do not interchange selector set parts with parts from other sets. Spool and sleeve (selector set) should be handled with care to prevent damage to mating surfaces.

10. Remove spool (18), sleeve (19), and two packings (20) from body (3). Use brass drift (21).
11. Remove body (3) from vise (17).

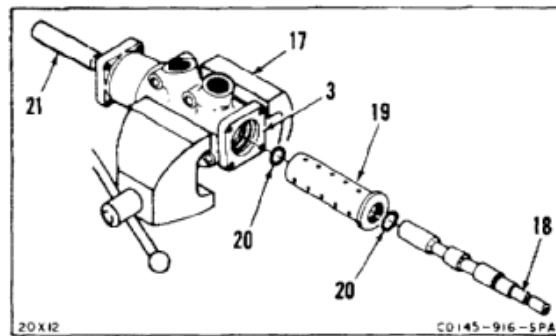

12. Remove six packings (22) and four retainers (23) from body (3).

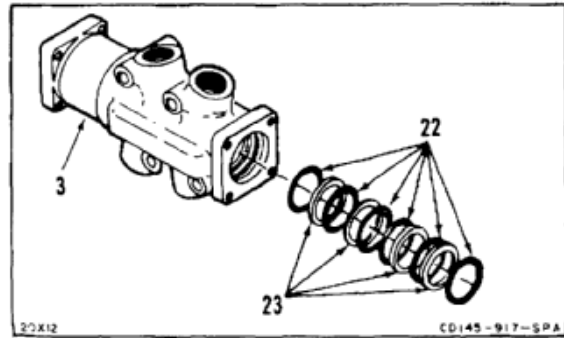

FOLLOW-ON MAINTENANCE:

Inspect cargo door sequence valve components (AVIM) (Task 7-277).

END OF TASK

7-1030

INITIAL SETUP

Applicable Configurations:

All

Tools:

- Technical Inspection Tool Kit, NSN 5180-00-323-5114
- Outside Micrometer Caliper Set
- Telescoping Gage Set
- Hole Gage, 0.200 to 0.300 Inch
- Spring Compression Tester

Materials:

- Marking Pencil (E271)
- Crocus Cloth (E122)

Personnel Required:

Inspector

References:

- TM 55-1520-240-23P
- Task 7-1.1

Equipment Condition:

Off Helicopter Task

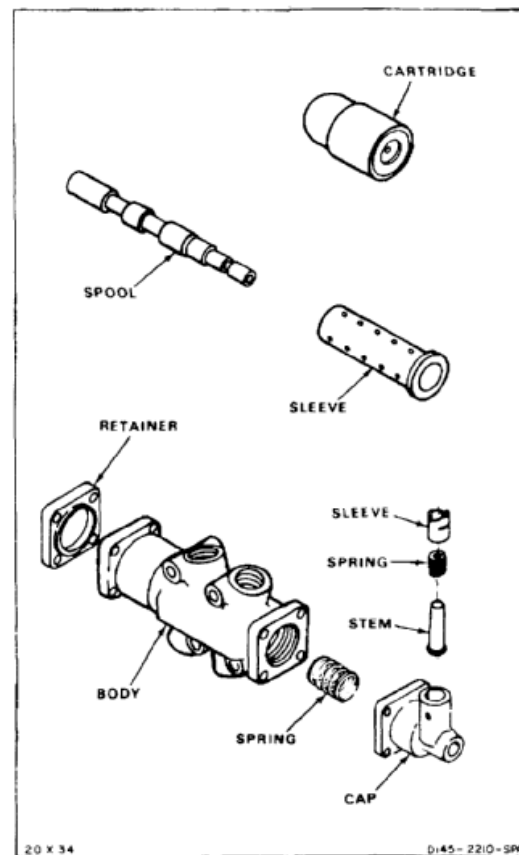

NOTE

General inspection criteria (Task 7-1.1) for obvious damage applies unless otherwise stated.

Inspection steps cover parts that are subject to wear.

1. Measure diameter of bore (1) in body (2). Diameter shall not be more than **1.001 inches**.
2. Measure diameter of cartridge (3). Diameter shall not be less than **0.998 inch**. Rounded end of cartridge shall have no burrs or other raised material. Remove with crocus cloth (E122).

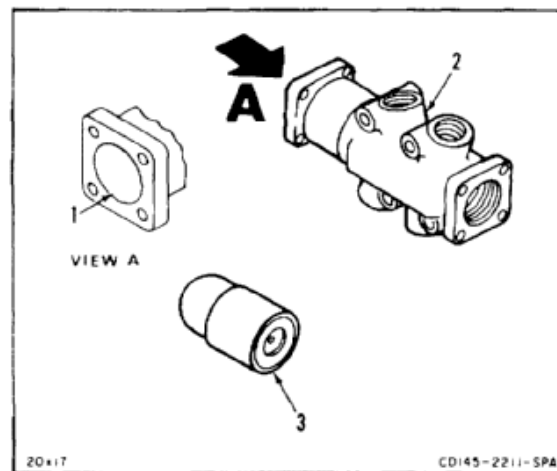

NOTE

Spool and sleeve are a matched set.
If one is damaged, both must be replaced.

3. Check that spool (4) slides easily in sleeve (5).
4. Measure diameter at two places (6) at end of spool (4). Diameters shall not be less than **0.278 inch**.
5. Inspect groove (7). Groove shall have no burrs or other raised material. Remove with crocus cloth (E122).

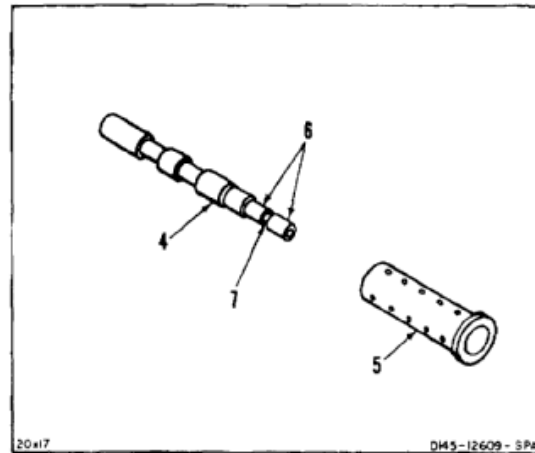

6. Measure diameter of sleeve (8). Diameter shall not be more than **0.312 inch**.
7. Measure diameter of stem (9). Diameter shall not be less than **0.310 inch**.
8. Check that stem (9) slides easily in sleeve (8). There shall be no binding.
9. Measure diameter of bore (10) in end of cap (11). Diameter shall not be more than **0.284 inch**.

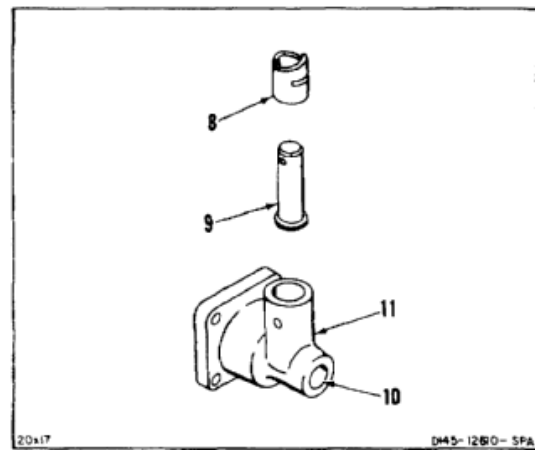

10. Check spring action of cartridge (3) as follows:
 - a. Apply pressure to spring guide (11) until spring guide starts to move into housing (12). Use spring compression tester (13). Spring guide shall not move until pressure is at least **25 pounds**.

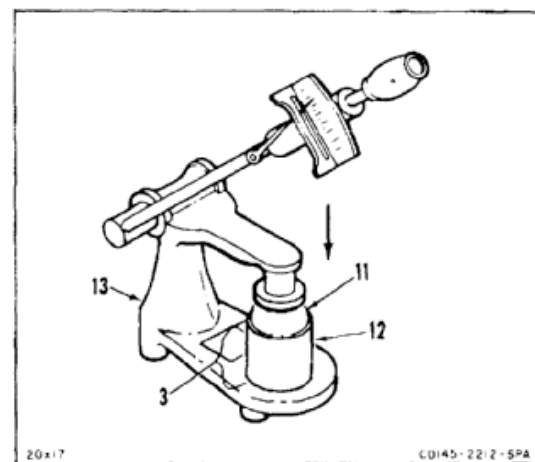

- b. Mark spring guide (11) **0.4 inch** from top of housing (12). Use marking pencil (E271).
- c. Apply pressure to spring guide (11) until mark aligns with top of housing (12). Use spring compression tester (13). Pressure to align mark and housing top shall not exceed **50 pounds**.

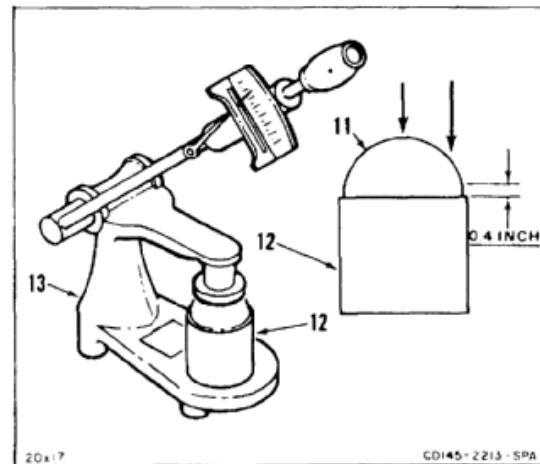

11. Measure free length of spring (14). Free length shall be **0.54 to 0.56 inch**.
12. Compress small spring (14) to **0.23 inch**. Use spring compression tester (13). Force needed to compress spring shall be **5.5 pounds**.

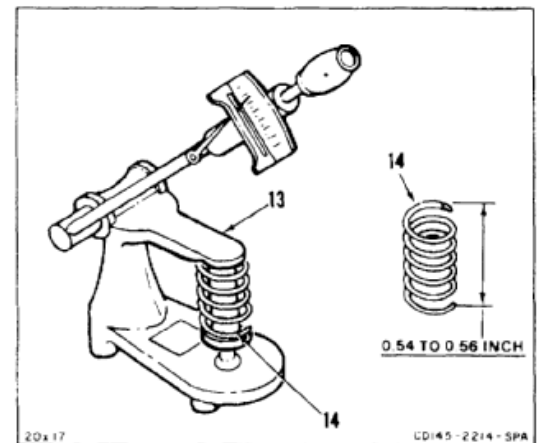

13. Compress large spring (15) to **0.65 to 0.66 inch**. Use spring compression tester (13). Force needed to compress spring shall be **9 to 11 pounds**.

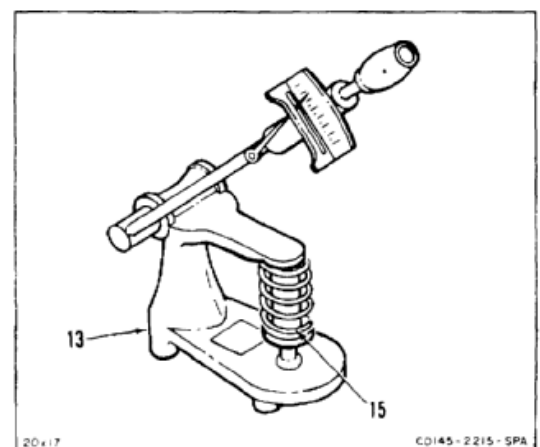
**FOLLOW-ON MAINTENANCE:**

None

END OF TASK

INITIAL SETUP

Applicable Configurations:

All

Tools:

Hydraulic Repairer's Tool Kit, NSN 5180-00-323-4891
Goggles

Materials:

Aluminum Oxide Abrasive Cloth (E1)
Crocus Cloth (E122)
Dry Cleaning Solvent (E162)
Gloves (E186)

Personnel Required:

Aircraft Pneudraulics Repairer
Inspector

References:

TM 55-1520-240-23P

Equipment Condition:

Off Helicopter Task
Cargo Door Sequence Valve Disassembled (Task
7-276)



Do not polish any part to the extent that plating is removed.

1. Polish minor nicks and scratches from selector set (1 and 2), cartridge (3), stem (4), and guide (5). Use crocus cloth (E122).

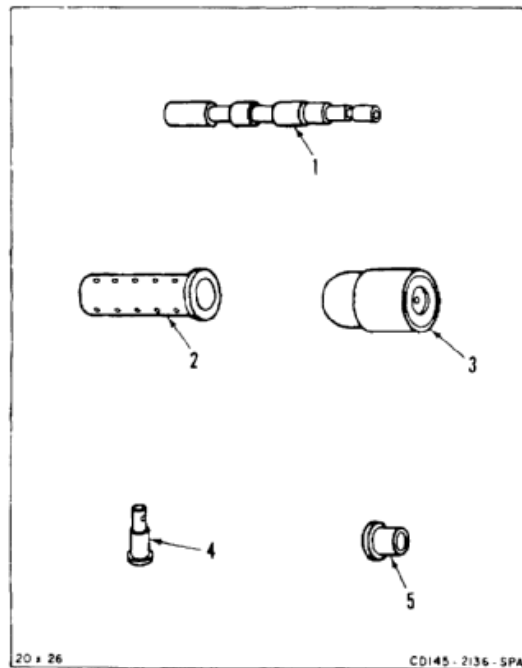

2. Polish minor nicks and scratches from retainer (6), cap (7), and body (8). Use aluminum oxide abrasive cloth (E1).

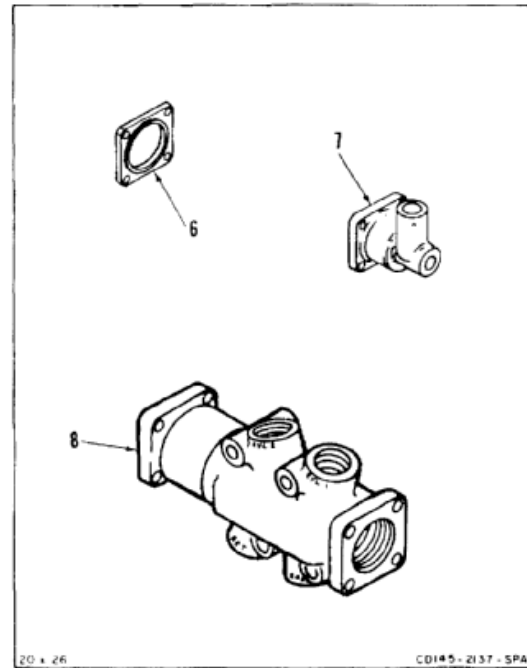

WARNING

Dry cleaning solvent (E162) is flammable and toxic. It can irritate skin and cause burns. Use only in well-ventilated area, away from heat and open flame. In case of contact, immediately flush skin or eyes with water for at least **15 minutes**. Get medical attention for eyes.

3. Clean polished parts (1 thru 8) with dry cleaning solvent (E162). Use goggles for eyes. Wear gloves (E186).

INSPECT

FOLLOW-ON MAINTENANCE:

None

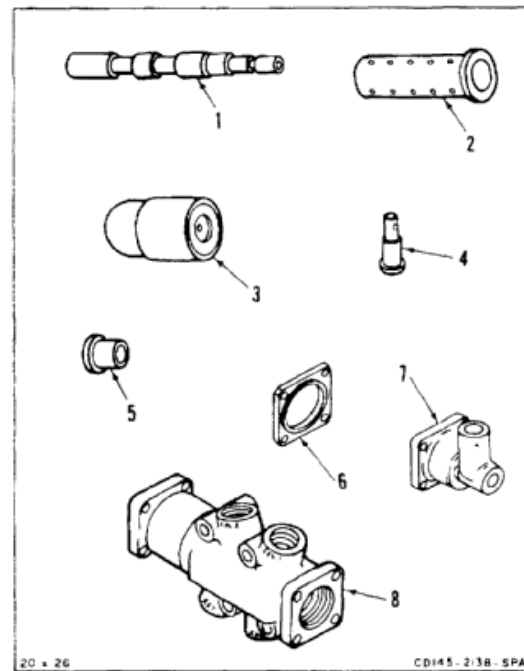

END OF TASK

INITIAL SETUP

Applicable Configurations:

All

Tools:

Hydraulic Repairer's Tool Kit, NSN 5180-00-323-4891
Soft Jawed Vise

Materials:

Lockwire (E231)

Parts:

Preformed Packing
Retainers

Personnel Required:

Aircraft Pneudraulics Repairer
Inspector

References:

TM 55-1520-240-23P

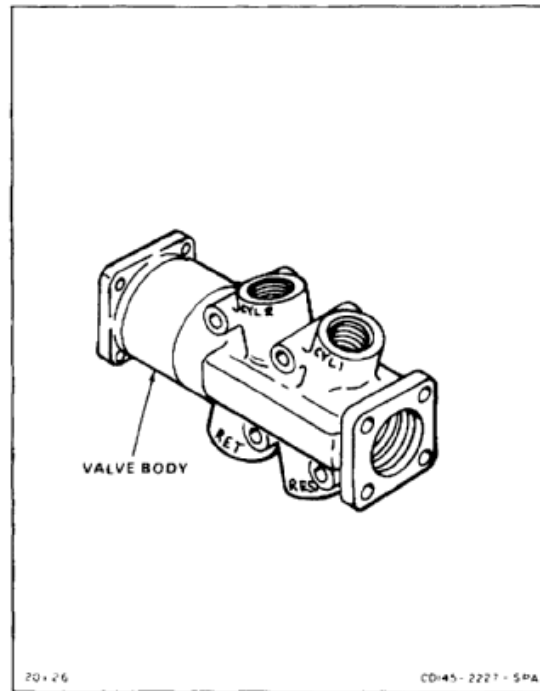

1. Install six packings (1) and four retainers (2) in body (3).

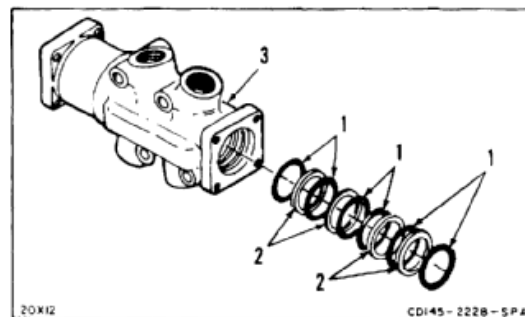

2. Clamp body (3) in vise (4). Install two packings (5) in sleeve (6).



Do not interchange selector set parts with parts from other sets. Keep spool and sleeve together as matched selector set.



Handle selector set carefully to prevent damage to mating surfaces.

3. Install spool (7) in sleeve (6).
4. Install sleeve (6) with spool (7) in body (3).
5. Install guide (8) and spring (9) in body (3).
6. Install cap (10) and four screws (11). Lockwire screws. Use lockwire (E231).

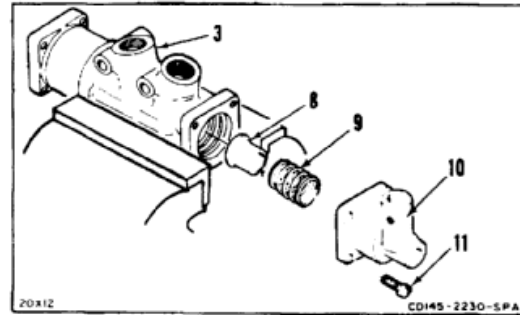
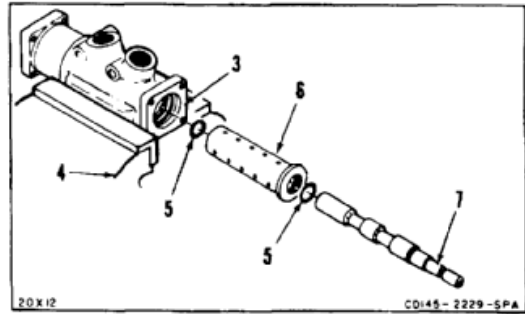

7. Install sleeve (12) and spring (13) on stem (14).
8. Push down on sleeve (12) and install pin (15) in stem (14).
9. Install stem (14) in cap (10).
10. Align groove in sleeve (12) with hole in cap (10) and install pin (16).
11. Install knob (17) and screw (18) in cap (10).

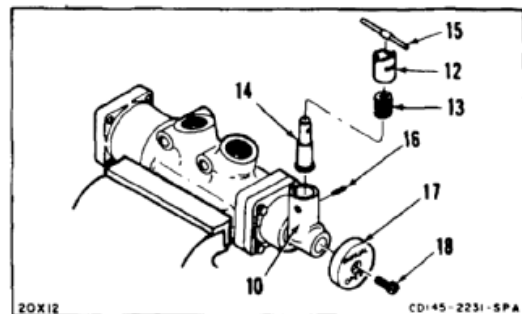

12. Install cartridge (19) in body (3).
13. Install retainer (20) and four screws (21).

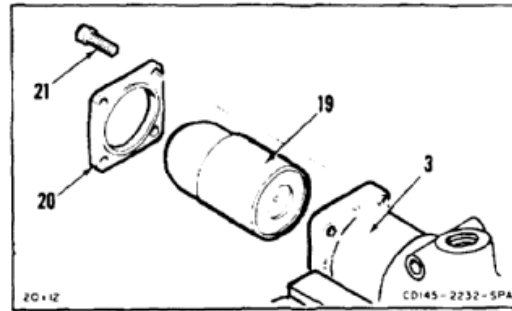

14. Lockwire screws (21). Use lockwire (E231).
15. Remove body (3) from vise (4).

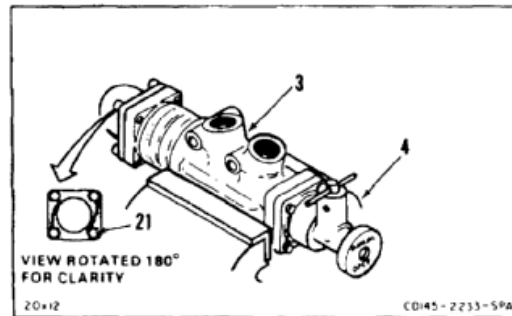

INSPECT

FOLLOW-ON MAINTENANCE:

Test cargo door sequence valve (Task 7-280).

END OF TASK

7-1038

INITIAL SETUP

Applicable Configurations:

All

Tools:

Hydraulic Repairer's Tool Kit, NSN 5180-00-323-4891
 Hydraulic Test Stand
 Reverse Spring Scale
 Shutoff Valve (3)
 Gage, 0 to 3000 psi (3)
 Flowmeter
 Flexible Hose, 1/4 Inch OD, Capable of 0 to 4500 psi

Materials:

Cloths (E120)
 Marking Pencil (E271)

Personnel Required:

Aircraft Pnedraulics Repairer
 Inspector

Equipment Condition:

Off Helicopter Task
 Hydraulic Test Setup
 Sequence Valve Installed in Crash-Proof Box

General Safety Instructions:**WARNING**

Use suitable crash box to shield personnel and equipment in case of failure during test.

WARNING

Hydraulic fluid (E199) is toxic. It can irritate skin and cause burns. Avoid inhaling. Use only with adequate ventilation. Avoid contact with skin, eyes, or clothing. In case of contact, immediately flush skin or eyes with water for at least **15 minutes**. Get medical attention for eyes.

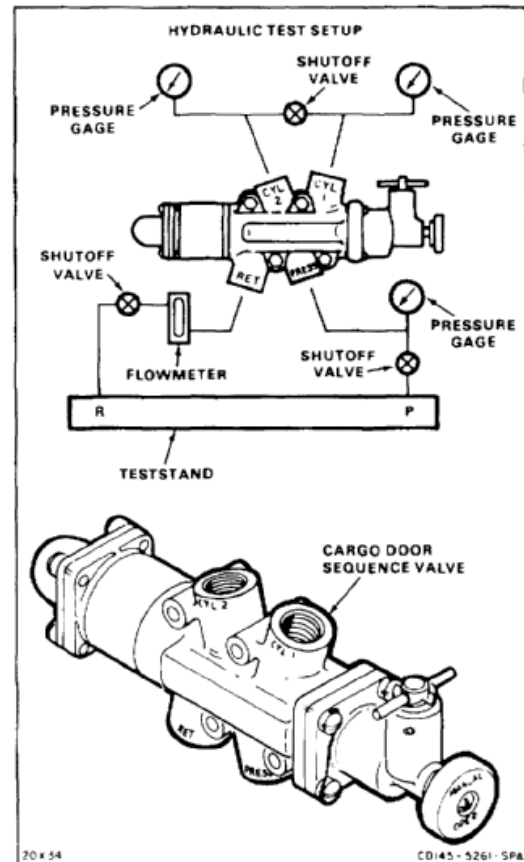

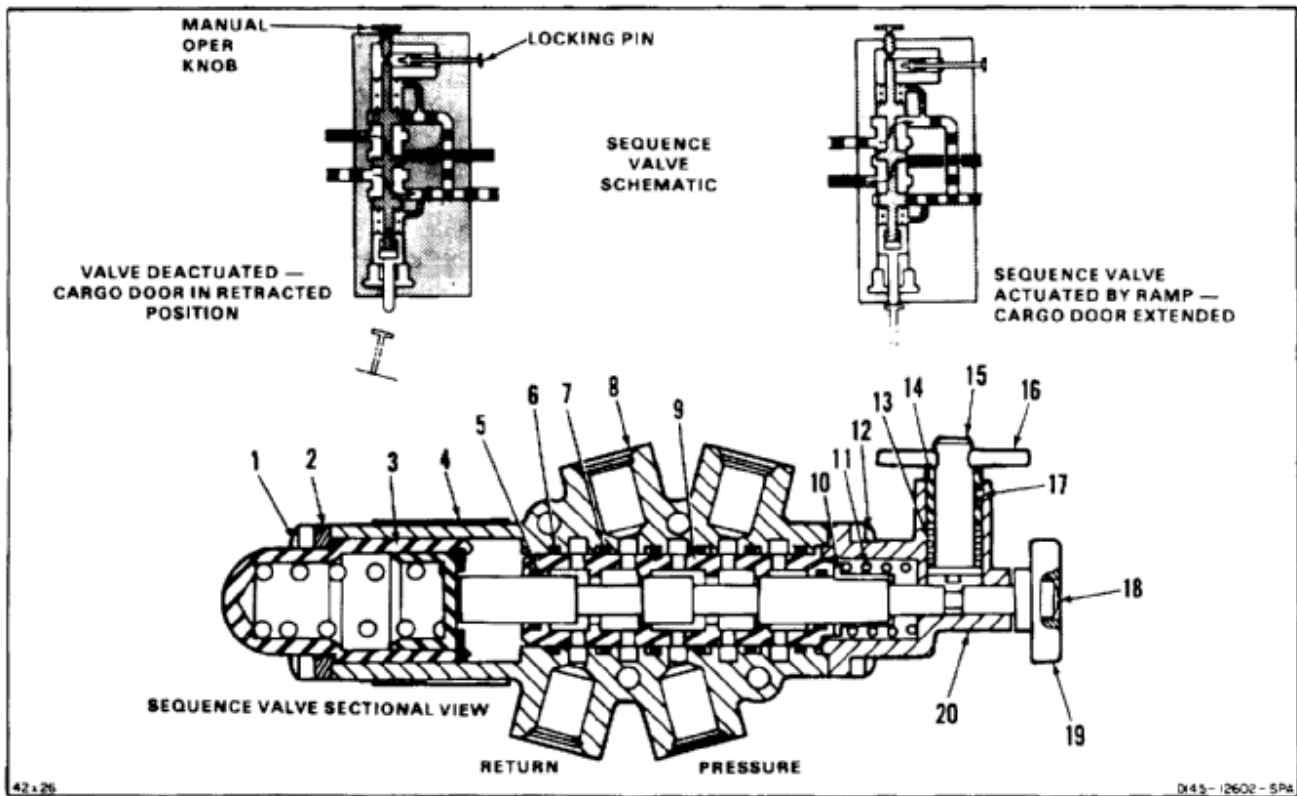

42-26

D45-12602-5Pa

- | | |
|------------------------------|-----------------|
| 1. Screw | 11. Spring |
| 2. Retainer | 12. Screw |
| 3. Spring cartridge assembly | 13. Spring |
| 4. Nameplate | 14. Sleeve |
| 5. Packing | 15. Stem |
| 6. Packing | 16. Pin |
| 7. Backup ring | 17. Lockpin |
| 8. Body | 18. Nylon screw |
| 9. Spool and sleeve assembly | 19. Knob |
| 10. Guide | 20. Cap |

7-280 TEST CARGO DOOR SEQUENCE VALVE (AVIM) (Continued)

1. Connect pressure hose (1) to PRESS port (2) of sequence valve (3).
2. Connect return hose (4) to RET port (5) of sequence valve (3).
3. Connect hose (6) to CYL 1 port (7) of sequence valve (3).
4. Connect hose (8) to CYL 2 port (9) of sequence valve (3).

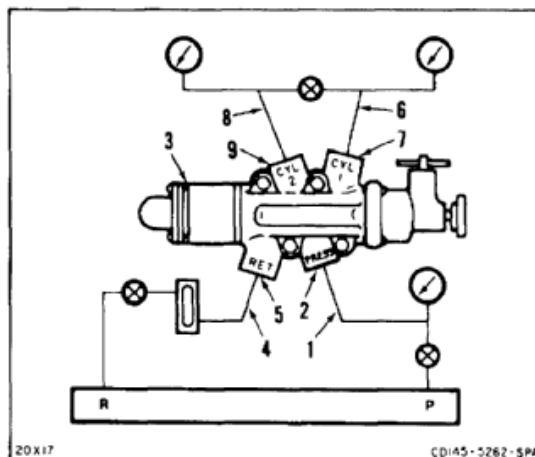

5. Open shutoff valves (10 and 11).
6. Close shutoff valve (12).
7. Push in MANUAL OPER knob (13). Apply **4500 psi** pressure to PRESS port (2). Maintain pressure for **2 minutes**.
8. Check sequence valve (3). There shall be no leaks or permanent deformation.
9. Reduce pressure at PRESS port (2) to **0 psi**.
10. Release MANUAL OPER knob (13).
11. Close shutoff valve (11).
12. Disconnect hose (4) from RET port (5).
13. Push in MANUAL OPER knob (13).
14. Apply **3000 psi** pressure to PRESS port (2). Maintain pressure for **3 minutes**. When **2 minutes** have passed, check RET port (5) for leaks. Leaks from RET port shall not exceed **20 drops per minute after 2 minutes**.
15. Reduce pressure at PRESS port (2) to **0 psi**.
16. Release MANUAL OPER knob (13).

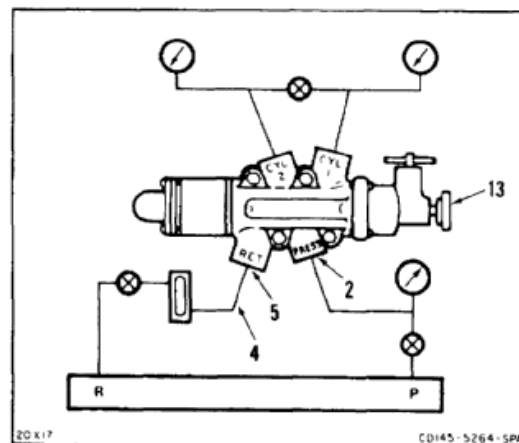
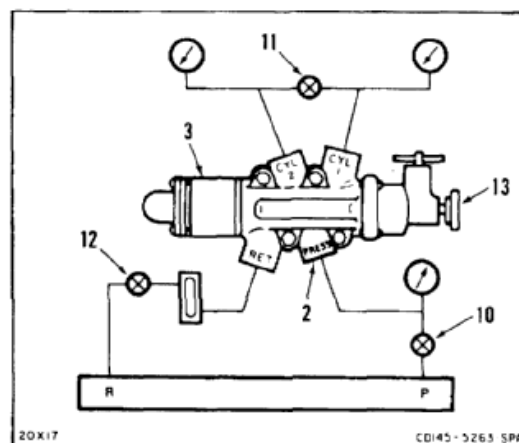

17. Connect hose (4) to RET port (5).
18. Mark cartridge (14) **0.20 inch** from housing (15). Use marking pencil (E271).
19. Push in and hold cartridge (14) until mark on cartridge aligns with housing (15).
20. Push in MANUAL OPER knob (13).
21. Apply **3000 psi** pressure to PRESS port (2). Maintain pressure for **3 minutes**. When **2 minutes** have passed, check RET port (5) for leaks. Leaks from RET port shall not exceed **20 drops per minute after 2 minutes**.
22. Check pressure reading at gage (16). Pressure reading shall be **3000 psi**.
23. Release cartridge (14).
24. Check pressure at gage (17). Pressure shall be **3000 psi**.
25. Open shutoff valve (11) slowly until flowmeter (18) shows **1 gpm** flow from RET port (5).
26. Release MANUAL OPER knob (13).
27. Apply force against cartridge (14) until it starts to move. Use reverse spring scale (19). Check force to move cartridge. Force shall be **9 to 15 pounds**.
28. Align mark on cartridge (14) with housing (15). Use reverse spring scale (19). Check force needed to align mark on cartridge with housing. Force shall not exceed **22 pounds**.
29. Check pressure at gage (16). Pressure shall be **3000 psi**.
30. Push cartridge (14) into housing (15) past alignment mark. Use reverse spring scale (19). Check force needed to push cartridge past alignment mark. Force shall be **25 pounds** or more.
31. Release cartridge (14).
32. Remove alignment mark from cartridge (14).
33. Reduce pressure at PRESS port (2) to **0 psi**.
34. Mark cartridge (14) **0.40 inch** from housing (15). Use marking pencil (E271).

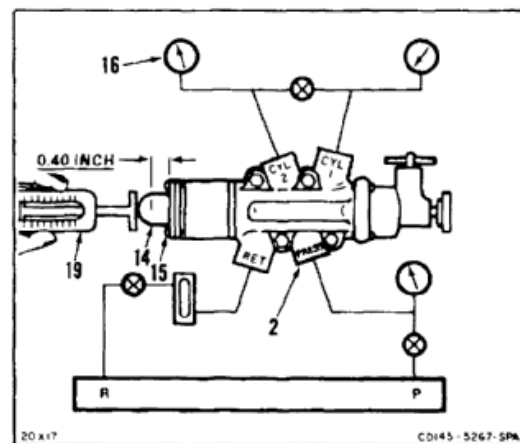
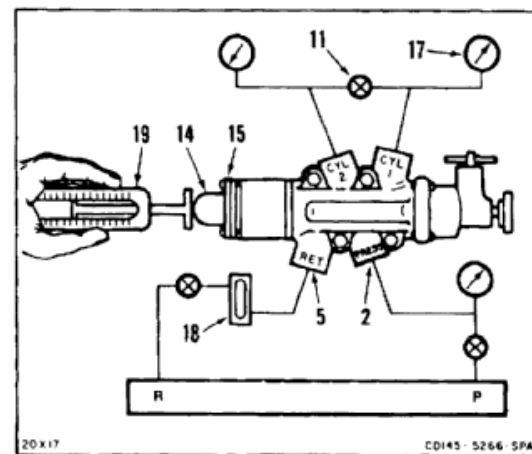
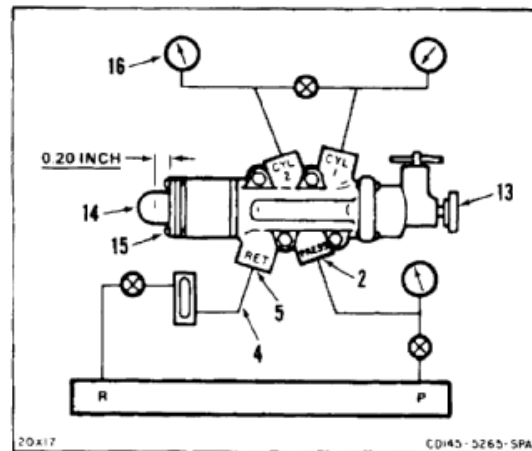

35. Push in cartridge (14) until mark aligns with housing (15). Use reverse spring scale (19).
36. Apply **3000 psi** to port (2).
37. Push in and hold MANUAL OPER knob (13).
38. Turn detent (20) clockwise.
39. Release MANUAL OPER knob (13).
40. Check force on scale (19) needed to keep mark on cartridge (14) aligned with housing (15). Force shall be **50 pounds** or less.

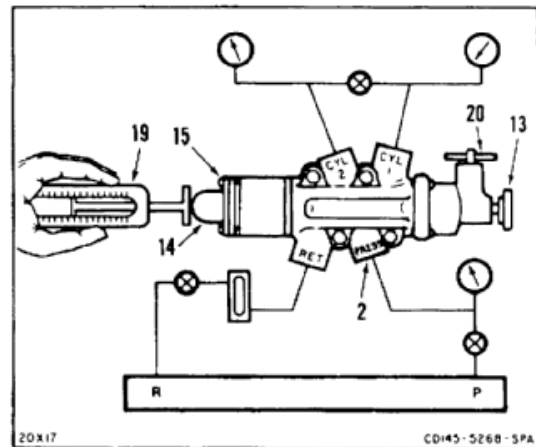

41. Check pressure at gage (17). Pressure shall be **3000 psi**.
42. Release cartridge (14).
43. Push in knob (13). Turn detent (20) counterclockwise until it locks in place.
44. Reduce pressure at port (2) to **0 psi**.
45. Disconnect hoses (1, 4, 6 and 8) from valve (3).
46. Remove alignment mark from cartridge (14).

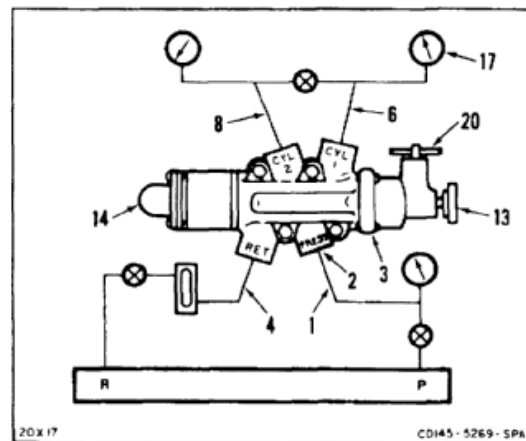

FOLLOW-ON MAINTENANCE:

None

END OF TASK

INITIAL SETUP

Applicable Configurations:

All

Tools:

Aircraft Mechanic's Tool Kit, NSN 5180-00-323-4692

Materials:

None

Parts:

Preformed Packings

Personnel Required:

Medium Helicopter Repairer
Inspector

References:

TM 55-1520-240-23P

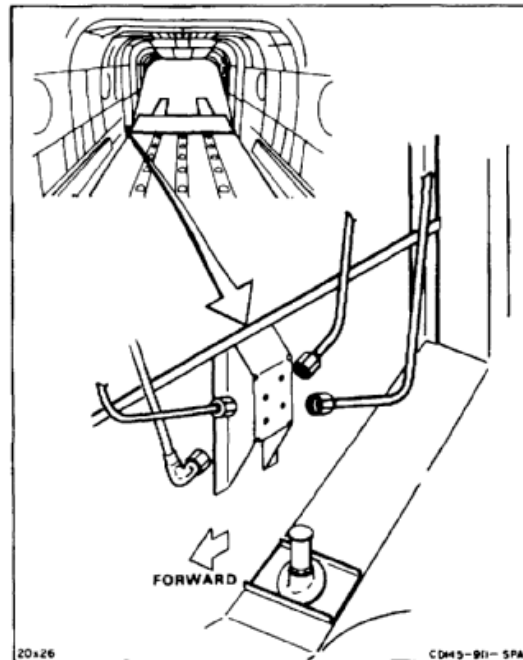

1. Install four packings (1), and nipples (2), in ports CYL 1, CYL 2, PRESS, and RET of valve (3).
2. Install packing (4) and restrictor (5) in port PRESS of valve (3).

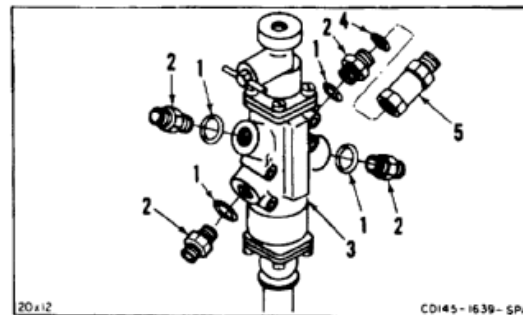

7-281 INSTALL CARGO DOOR SEQUENCE VALVE (Continued)**7-281**

3. Position valve (3) on mount (6). Install four washers (7) and bolts (8).

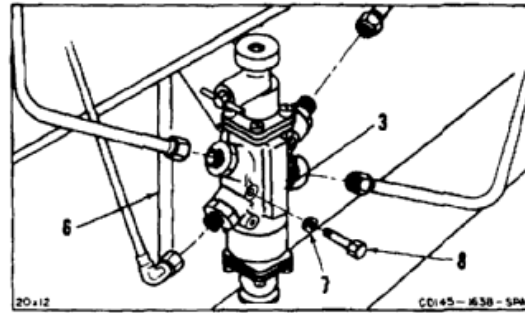

4. Connect four tubes (9). Remove tags.

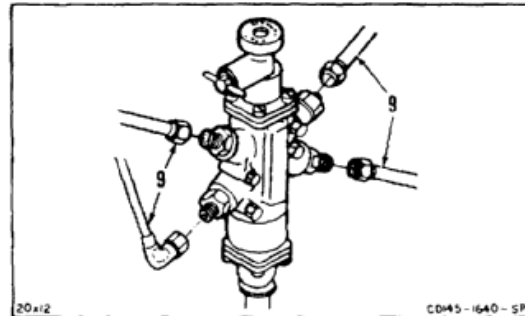
**INSPECT****FOLLOW-ON MAINTENANCE:**

- Bleed utility hydraulic system (Task 7-339).
- Perform operational check (TM 55-1520-240-T).
- Adjust cargo door sequence valve (Task 7-282).

END OF TASK

INITIAL SETUP

Applicable Configurations:

All

Tools:

Aircraft Mechanic's Tool Kit, NSN 5180-00-323-4692

Materials:

None

Personnel Required:

Medium Helicopter Repairer

Equipment Condition:

- Battery Connected (Task 1-39)
- Electrical Power On
- Hydraulic Power On
- RAMP Switch Set to ON
- Cargo Ramp Fully Down (TM 55-1520-240-T)
- EMERG UTIL PRESS VALVE Set to NORMAL
- RAMP CONTROL Handle Set to STOP

General Safety Instructions:

WARNING

Make sure jettisonable cargo door and cargo ramp are clear of personnel and equipment. Serious injury to personnel and damage to equipment can result when ramp is raised or lowered.

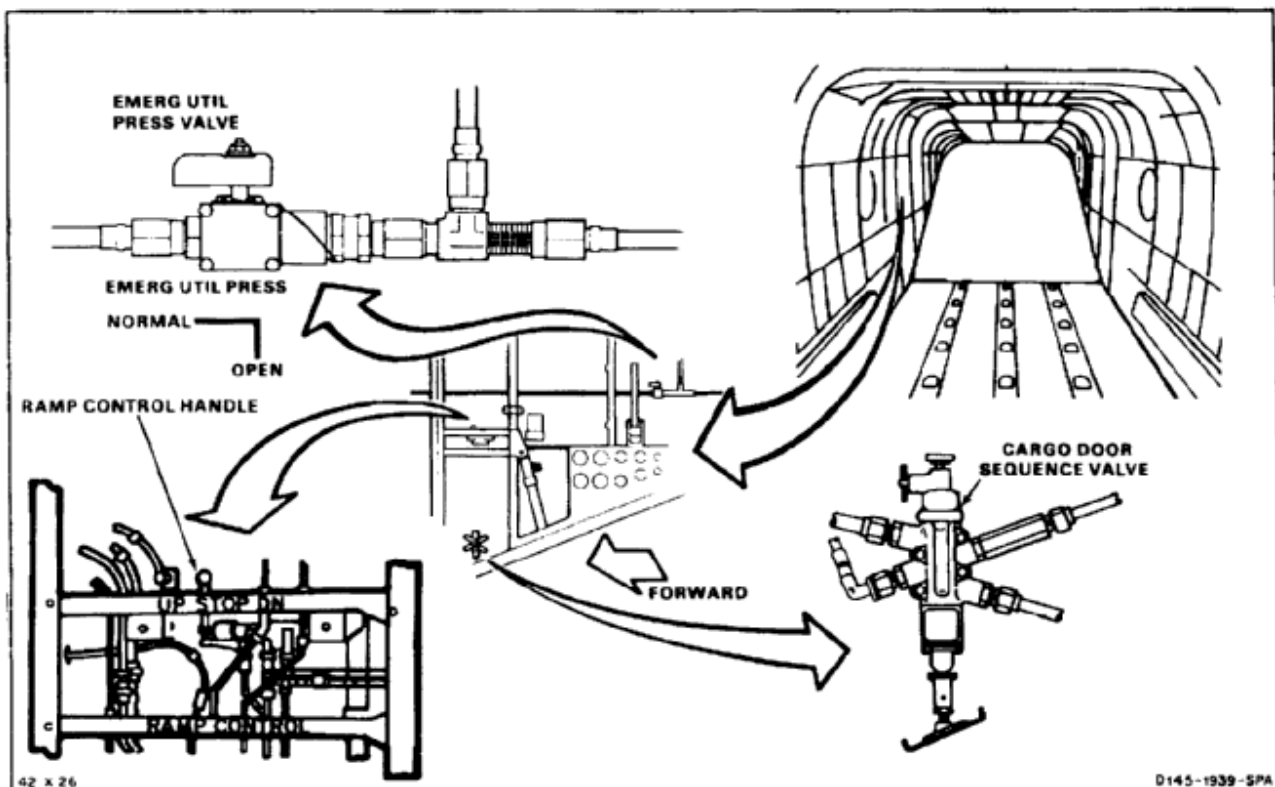

1. Loosen locknut (1). Turn rod end (2) clockwise until it bottoms.

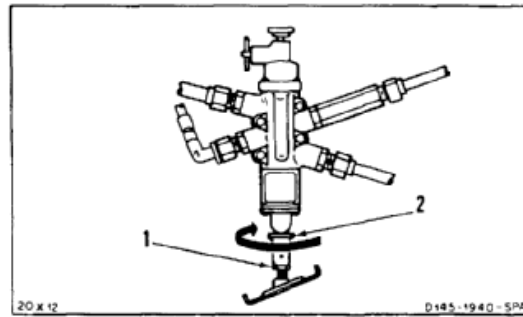

2. Set ramp control handle (3) to UP. Raise ramp fully up. Set ramp control handle to STOP.

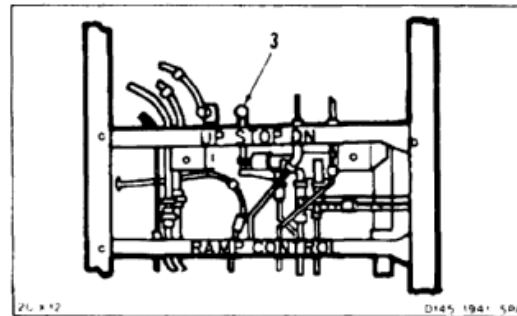

3. Turn rod end (2) until it touches cartridge (4).

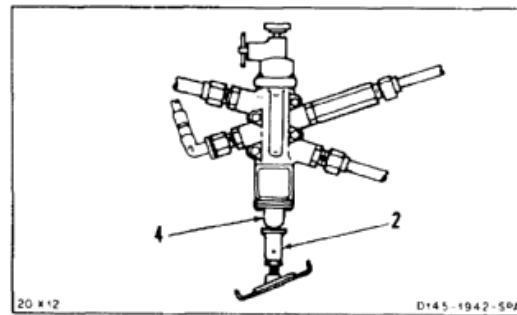

4. Set ramp control handle (3) to DN. Lower ramp fully down. Set ramp control handle to STOP.

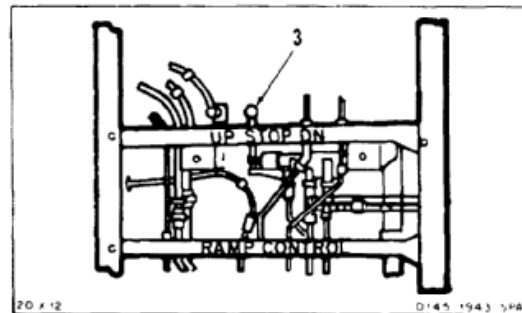

5. Turn rod end (2) counterclockwise until it is **0.30 inch** from original position.

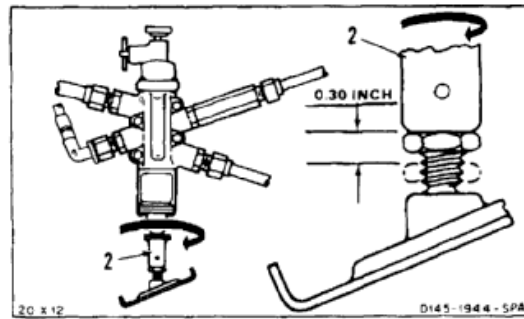

6. Set ramp control handle (3) to UP. Raise ramp fully up. Set ramp control handle to STOP.

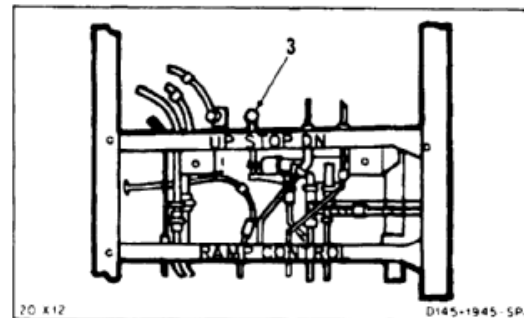

7. Turn EMERG UTIL PRESS valve handle (5) to OPEN.

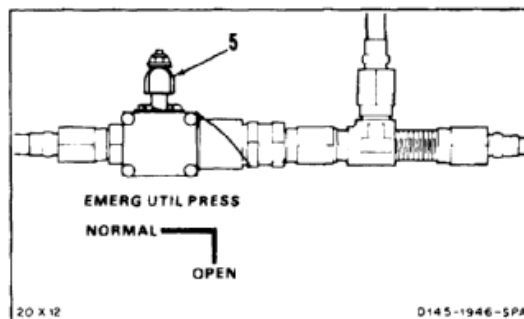

8. Push down and hold MANUAL OPER knob (6). Turn lockpin handle (7) **90°** to lock MANUAL OPER knob. If knob is not locked down, turn rod end (2) clockwise until knob is locked.
9. Turn handle (7) to vertical position to release knob (6). Check hole (8) to ensure thread shows.
10. Tighten locknut (1).

FOLLOW-ON MAINTENANCE:

Perform operational check of cargo door sequence valve (TM 55-1520-240-T).

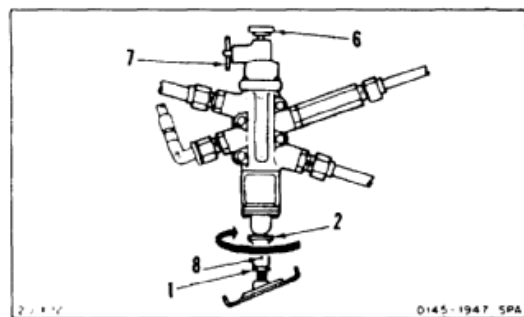

END OF TASK

INITIAL SETUP

Applicable Configurations:

All

Tools:

Aircraft Mechanic's Tool Kit, NSN 5180-00-323-4692

Materials:

Cloths (E120)
 Paper Tags (E264)
 Gloves (E186)

Personnel Required:

Medium Helicopter Repairer

Equipment Condition:

Battery Disconnected (Task 1-39)
 Electrical Power Off
 Hydraulic Power Off
 Utility Hydraulic System Depressurized (Task 7-135.1)
 Cargo Ramp Down and Level (TM 55-1520-240-T)

General Safety Instructions:**WARNING**

Hydraulic fluid (E199) is toxic. It can irritate skin and cause burns. Avoid inhaling. Use only with adequate ventilation. Avoid contact with skin, eyes, or clothing. In case of contact, immediately flush skin or eyes with water for at least **15 minutes**. Get medical attention for eyes.

WARNING

Hydraulic fluid ejected under pressure can cause injury to personnel. Hydraulic fluid sprayed into the air is a fire hazard.

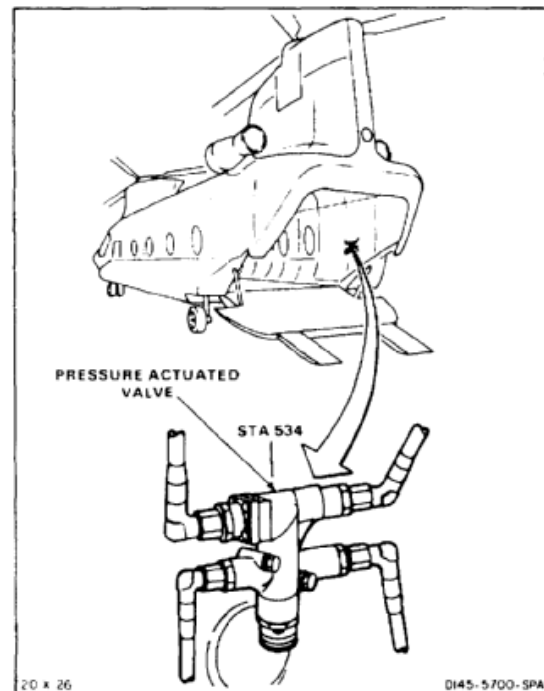

1. Tag and disconnect four hydraulic tubes (1) from valve (2). Use cloths (E120) for spilled fluid. Use gloves (E186).
2. Remove two nuts (3), four washers (4), two spacers (5), and two bolts (6) from valve (2). Remove valve.

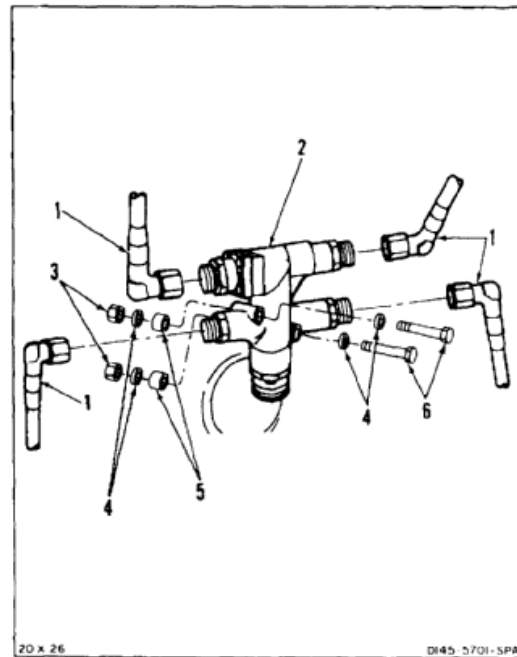

3. Remove four nipples (7) and packings (8) from valve (2).

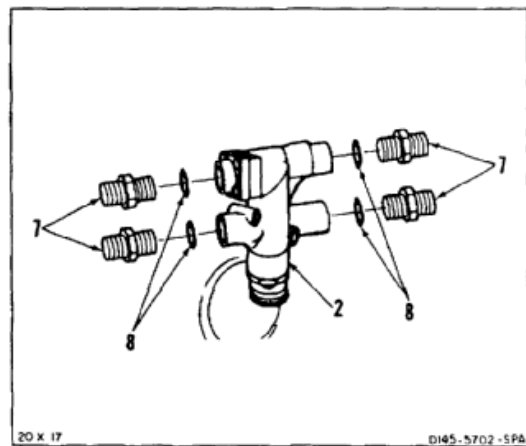
**FOLLOW-ON MAINTENANCE:**

None

END OF TASK

7-1050

7-283.1 DISASSEMBLE CARGO DOOR PRESSURE ACTUATED VALVE

7-283.1

INITIAL SETUP

Applicable Configurations:

All

Tools:

Hydraulic Repairer's Tool Kit, NSN 5180-00-323-4891

Materials:

None

Personnel Required:

Aircraft Pneudraulics Repairer

Equipment Condition:

Off Helicopter Task

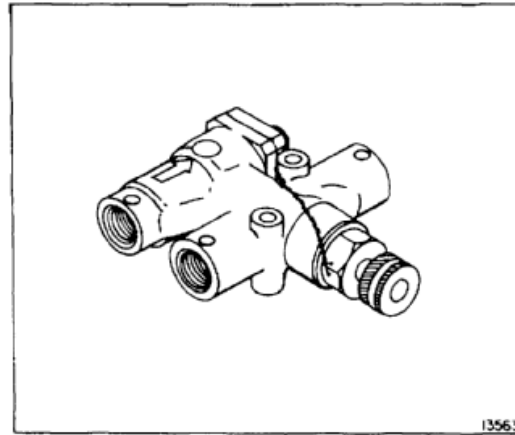
**NOTE**

Do not remove identification plate unless damaged and replacement required.

Carefully note method of lockwiring valve for later assembly.

1. Remove lockwire, four screws (1), and closure (2) from valve body (3).
2. Remove packing (4) from closure (2).

WARNING

Cage is spring-loaded. Restrain cage when removing locknut to prevent personal injury.

CAUTION

Handle poppet with care to prevent damage to mating surfaces.

3. Remove locknut (5), cage (6), spring (7), and poppet (8) from valve body (3).

CAUTION

Handle piston with care to prevent damage to mating surfaces.

4. Remove piston (9), spring (10), and plate (11).
5. Remove packing (12) from piston (9).

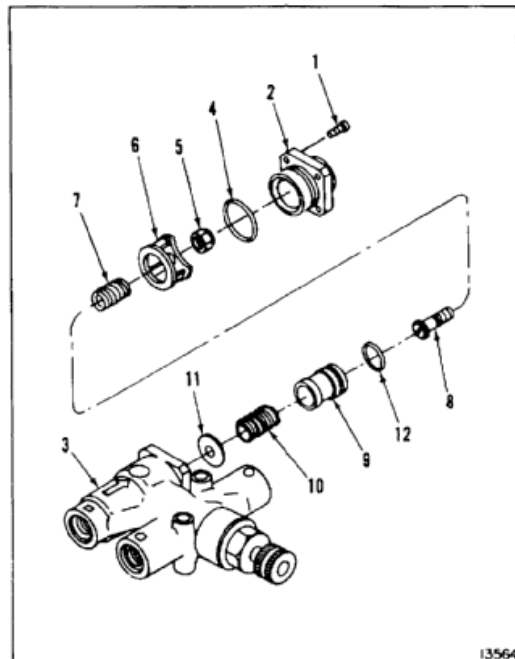

6. Remove ring (13) from knob (14).
7. Remove pin (15) and knob (14) from plunger (16).

WARNING

Plunger is spring-loaded. Restrain plunger when removing closure to prevent personal injury.

8. Remove lockwire and closure (17) from valve body (3).
9. Remove packing (18) from closure (17).
10. Remove plunger (16) and spring (20).
11. Remove packing (19) from plunger (16).

CAUTION

Handle lap fit assembly carefully to prevent damage to critical mating surfaces. Spool and sleeve are lapped and matched parts. Keep together; individual components are not interchangeable.

12. Remove lap fit assembly (21) from valve body (3).
13. Remove spool (22) from sleeve (23).
14. Remove packing (24) from spool (22).
15. Remove retainers (25) and packings (26) from sleeve (23).

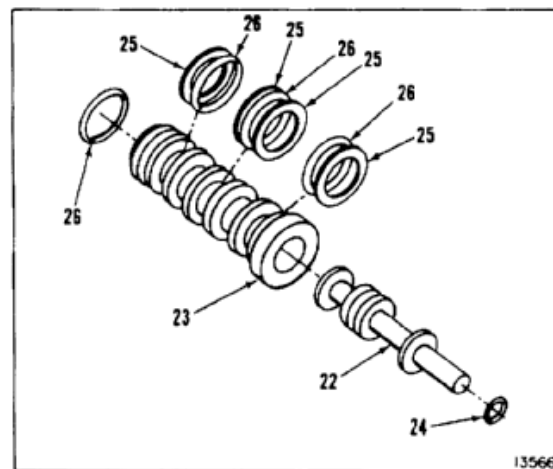
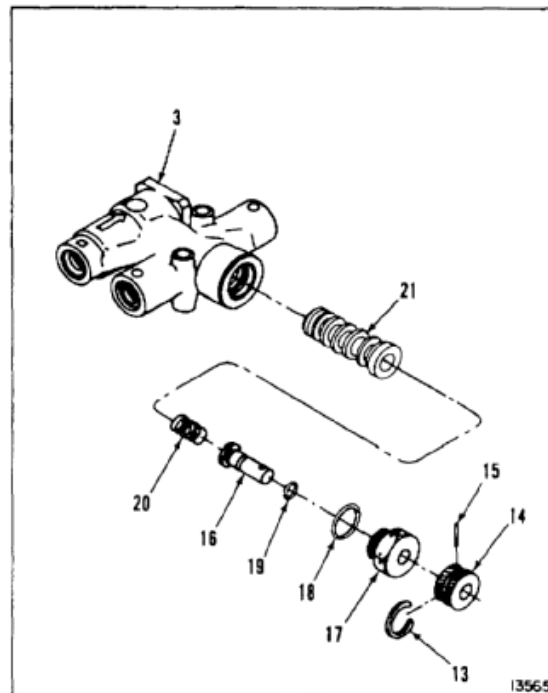
**FOLLOW-ON MAINTENANCE:**

Clean and inspect cargo door pressure actuated valve (Task 7-283.2).

END OF TASK

7-1052

INITIAL SETUP

Applicable Configurations:

All

Tools:

Technical Inspection Tool Kit, NSN 5180-00-323-5114
Spring Compression Tester

Materials:

Dry Cleaning Solvent (E162)

Personnel Required:

Inspector

Equipment Condition:

Off Helicopter Task
Cargo Door Pressure Actuated Valve Disassembled
(Task 7-283.1)

References:

Task 7-1.1

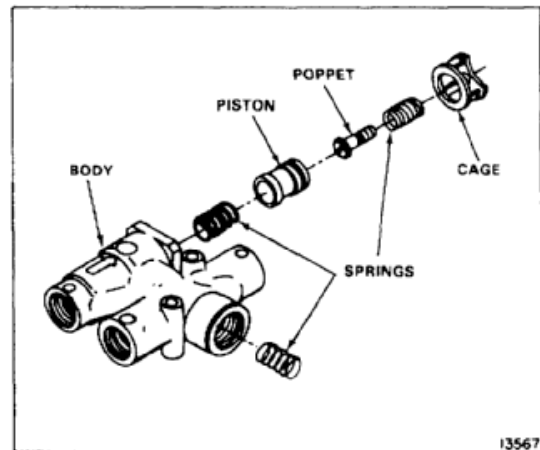
**WARNING**

Solvent (E162) is combustible and toxic. It can irritate skin and cause burns. Use only with adequate ventilation, away from open flame. In case of contact, immediately flush skin or eyes with water for at least **15 minutes**. Get medical attention for eyes.

1. Clean all components with solvent (E162) and dry thoroughly with clean dry compressed air.

NOTE

General inspection criteria (Task 7-1.1) for obvious damage applies unless otherwise stated.

Inspection steps cover parts that are subject to wear.

2. Measure diameter of shank (1) of poppet (2). Diameter shall not be less than **0.1330 inch**. Inspect shank and spherical seating radius (3) for nicks, scratches, and signs of wear at contact area.
3. Measure diameter of poppet bore (4) of cage (5). Diameter shall not be more than **0.1405 inch**.

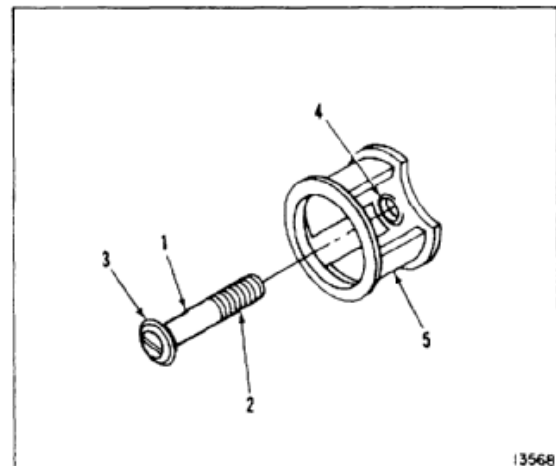

4. Measure outside diameter of three lands (6) of piston (7). Diameter shall not be less than **0.5575 inch**. The seating surface shall have a sharp edge and be free from nicks and burrs.
5. Measure bore (8) of valve body (9) that mates with piston (7). Diameter shall not be more than **0.5640 inch**.

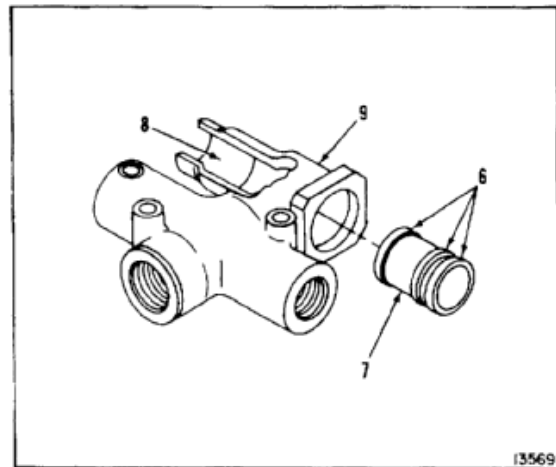

6. Inspect springs (10, 11, and 12) for distortion by rolling on a flat surface. There shall be no wobble present.
7. Measure free length of springs (10, 11, and 12):
 - a. Length of spring (10) shall be between **0.600 and 0.630 inch**.
 - b. Length of spring (11) shall be between **0.703 and 0.733 inch**.
 - c. Length of spring (12) shall be between **0.845 and 0.865 inch**.
8. Measure compressed length of springs (10, 11, and 12) in a spring compression tester (13):
 - a. With **0.28 pound** of force applied, length of spring (10) shall not be less than **0.280 inch**.
 - b. With **26.0 pounds** of force applied, length of spring (11) shall not be less than **0.562 inch**.
 - c. With **3.85 pounds** of force applied, length of spring (12) shall not be less than **0.450 inch**.

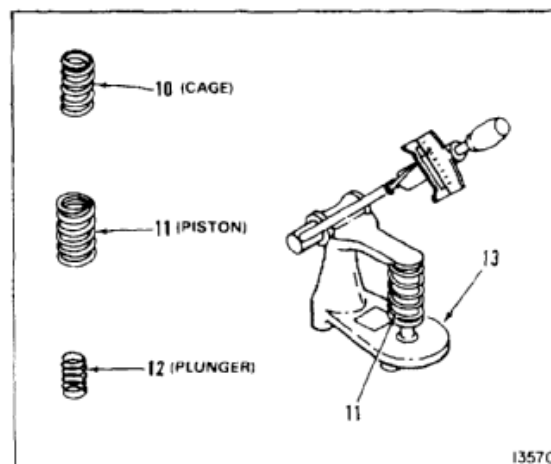

FOLLOW-ON MAINTENANCE:

Repair cargo door pressure actuated valve (Task 7-283.3).

END OF TASK

7-1054

INITIAL SETUP

Applicable Configurations:

All

Tools:

Hydraulic Repairer's Tool Kit, NSN 5180-00-323-4891
Goggles

Materials:

Crocus Cloth (E122)
Aluminum Oxide Abrasive Cloth (E1)
Dry Cleaning Solvent (E162)
Gloves (E186)

Personnel Required:

Aircraft Hydraulic Repairer
Inspector

Equipment Condition:

Off Helicopter Task
Cargo Door Pressure Actuated Valve Disassembled,
Cleaned, and Inspected (Tasks 7-283.1 and
7-283.2)

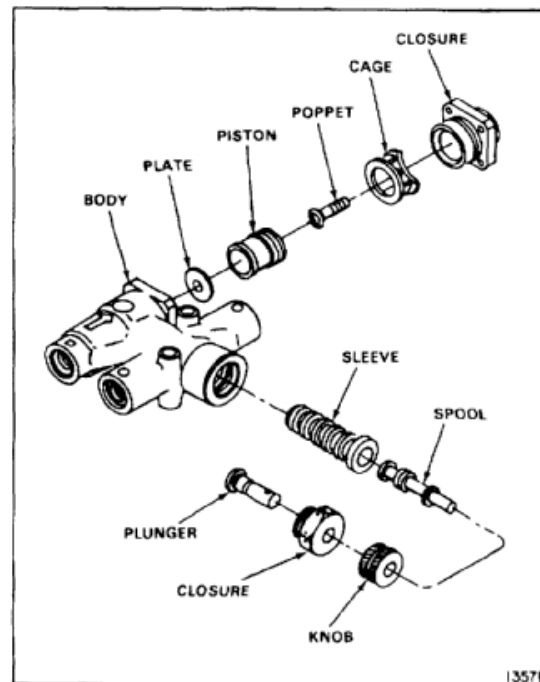

Do not polish any part to the extent that plating is removed or dimensional requirement cannot be maintained.



Handle poppet (3) and piston (2) carefully to avoid damage to mating surfaces.



Spool (5) and sleeve (6) are lap fitted parts. Surface finish of lap fitted parts is critical; handle carefully to avoid damage to critical mating surfaces. If either spool or sleeve is damaged, replace both parts as an assembly.

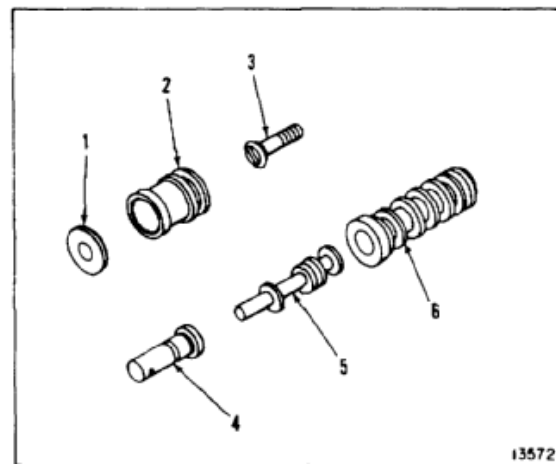

1. Polish minor nicks or scratches from plate (1), piston (2), poppet (3), plunger (4), spool (5), and sleeve (6). Use crocus cloth (E122).

- Polish minor nicks and scratches from body (1), cage (2), closures (3 and 4), and knob (5). Use aluminum oxide abrasive cloth (E1). Use only crocus cloth (E122) on bore of body (1).

WARNING

Solvent (E162) is combustible and toxic. It can irritate skin and cause burns. Use only with adequate ventilation, away from open flame. In case of contact, immediately flush skin or eyes with water for at least **15 minutes**. Get medical attention for eyes.

- Clean polished parts with dry cleaning solvent (E162). Use goggles for eyes. Wear gloves (E186).

FOLLOW-ON MAINTENANCE:

None

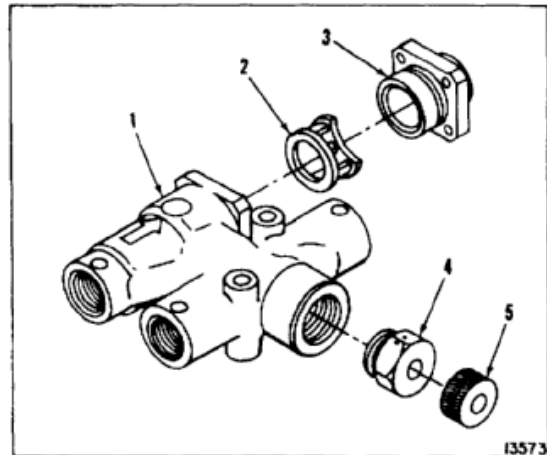

END OF TASK

7-1056

7-283.4 ASSEMBLE CARGO DOOR PRESSURE ACTUATED VALVE

7-283.4

INITIAL SETUP

Applicable Configurations:

All

Tools:

Hydraulic Repairer's Tool Kit, NSN 5180-00-323-4891

Materials:

Lockwire (E231)

Parts:

Preformed Packings
Retainers

Personnel Required:

Aircraft Pneudraulics Repairer
Inspector

References:

TM 55-1520-240-23P

Equipment Condition:

Off Helicopter Task
Cargo Door Pressure Actuated Valve Cleaned,
Inspected, and Repaired (Tasks 7-283.1, 7-283.2,
and 7-283.3)

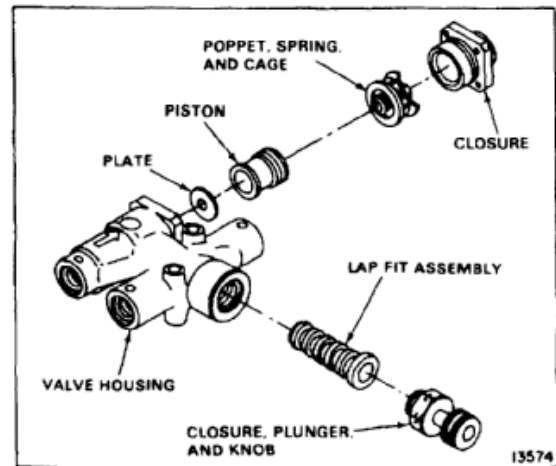

Handle lap fit assembly (6) (spool and sleeve) carefully to prevent damage to critical mating surfaces.

1. Install four retainers (1) and four packings (2) on sleeve (3).
2. Install packing (4) on spool (5).
3. Install spool (5) in sleeve (3).
4. Install spring (7) over spool (5) in sleeve (3).
5. Install lap fit assembly (6) in body (8).

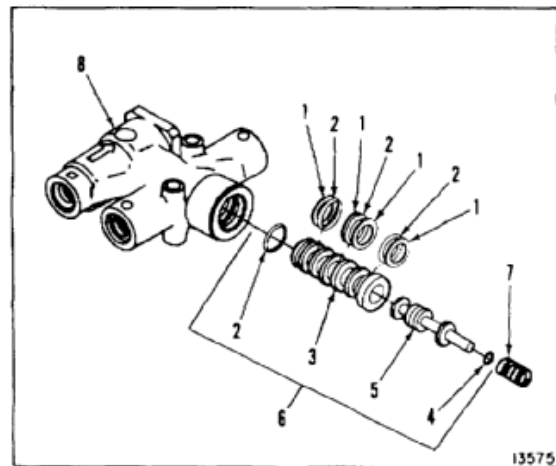

6. Install packing (9) on plunger (10) and packing (11) on closure (12).
7. Assemble plunger (10), closure (12), and knob (13).
8. Install pin (14) through knob (13) and plunger (10). Secure pin with ring (15).
9. Install assembled plunger (10), closure (12), and knob (13) in body (8).

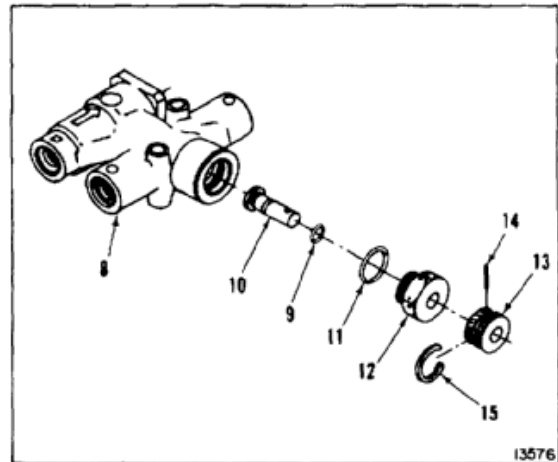

10. Install plate (16) in valve body (8).
11. Install packing (17) on piston (18).
12. Install spring (19) in piston (18).
13. Install piston (18) in valve body (8).

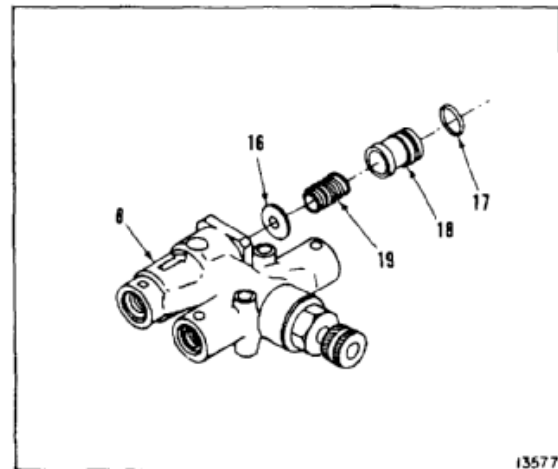

14. Assemble poppet (20), spring (21), cage (22), and locknut (23). Install assembly in valve body (8).
15. Install packing (24) on closure (25).
16. Install closure (25) in valve body (8) with four screws (26).
17. Lockwire four screws (26) and closure (12). Use lockwire (E231).

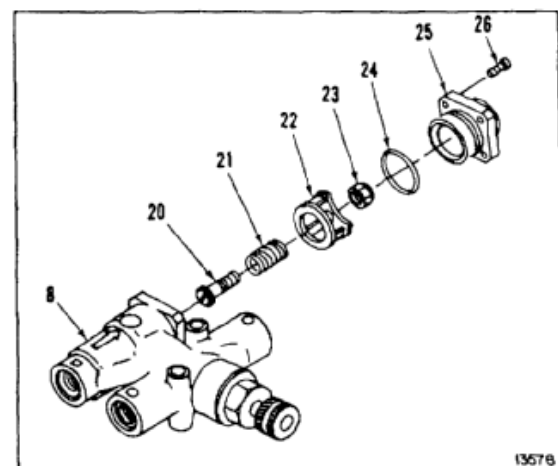

FOLLOW-ON MAINTENANCE:

Test cargo door pressure actuated valve (Task 7-283.5).

END OF TASK

7-1058

7-283.5 TEST CARGO DOOR PRESSURE ACTUATED VALVE

7-283.5

INITIAL SETUP**Applicable Configurations:**

All

Tools:

Hydraulic Repairer's Tool Kit, NSN 5180-00-323-4891
 Hydraulic Test Stand Capable of Providing Separate
 Controlled Pressures Up to 4500 psig and 0 to 300
 psig Simultaneously
 Needle Valve (2)
 Shutoff Valve
 Normally Open Zero Leakage Solenoid 2-Way Valve
 Flowmeter, 0 to 2 gpm
 Gage, 0 to 200 psig
 Gage, 0 to 4500 psig

Materials:

Hydraulic Fluid (E199)

Personnel Required:

Aircraft Pneudraulics Repairer
 Inspector

Equipment Condition:

Off Helicopter Task
 Valve Installed in Hydraulic Test Setup Valve in Crash
 Proof Box

General Safety Instructions:**WARNING**

Use suitable crash box to shield personnel and equipment in case of failure during test.

WARNING

Hydraulic fluid (E199) is toxic. It can irritate skin and cause burns. Avoid inhaling. Use only with adequate ventilation. Avoid contact with skin, eyes, or clothing. In case of contact, immediately flush skin or eyes with water for at least **15 minutes**. Get medical attention for eyes.

PREPARATIONS

1. Hydraulic test stand shall be filled with hydraulic fluid (E199).
2. Test fluid temperature shall be maintained between **70° and 110°F (35° and 58°C)**.

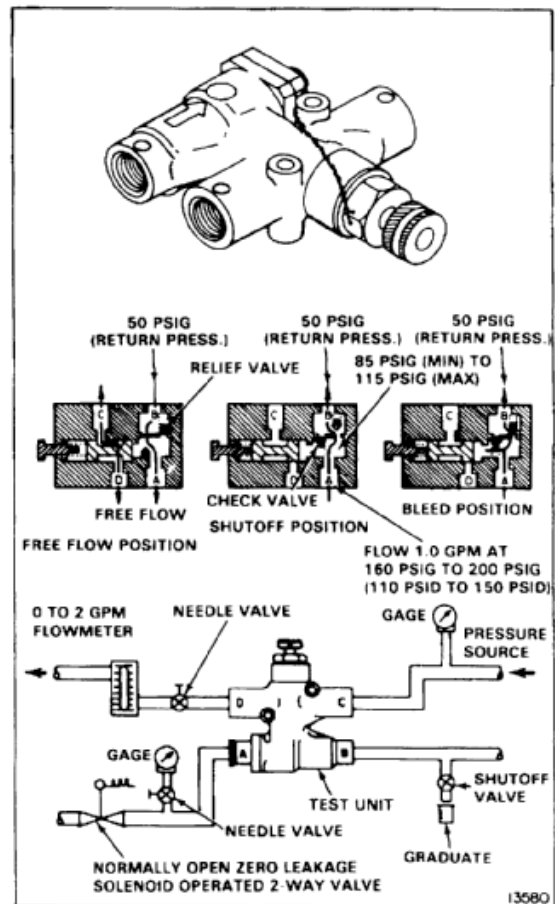

PROOF PRESSURE TEST

1. Connect test stand pressure hose (1) to port C of valve (2).
2. Connect test stand pressure hose (3) to port B of valve (2).
3. Install pressure caps on ports A and D.
4. Simultaneously apply **4500 psig** pressure at port C and **300 psig** pressure at port B. Hold for **2 minutes**.
5. Release pressure at ports C and B and repeat step 4. There shall be no evidence of external leakage or permanent set.

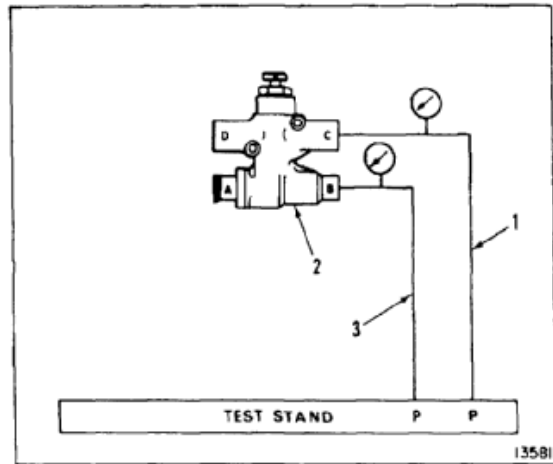

FREE FLOW CHECK (PORT C TO D)

6. Remove pressure cap from port D of valve (2) and pressure hose from port B.
7. Install pressure cap on port B.
8. Install test stand return hose (4) in port D.
9. Apply **100 psig** pressure at port C through hose (1).
10. Adjust needle valve (5) until flowmeter (6) indicates **1.2 gpm** at port D. Port D pressure shall be **50 psig** minimum.

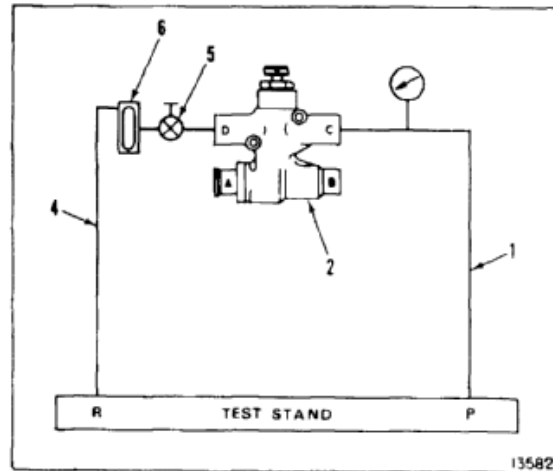

FREE FLOW CHECK (PORT B TO A)

11. Disconnect pressure hose (1) from port C of valve (2).
12. Disconnect return hose from port D.
13. Install pressure caps on port C and D.
14. Connect test stand pressure hose (3) at port B.
15. Connect test stand return hose (7) at port A.
16. Apply **50 psig** pressure at port B.
17. Adjust needle valve (8) until test stand flowmeter indicates **1.2 gpm** at port A. Port A pressure shall be **37 psig** minimum.

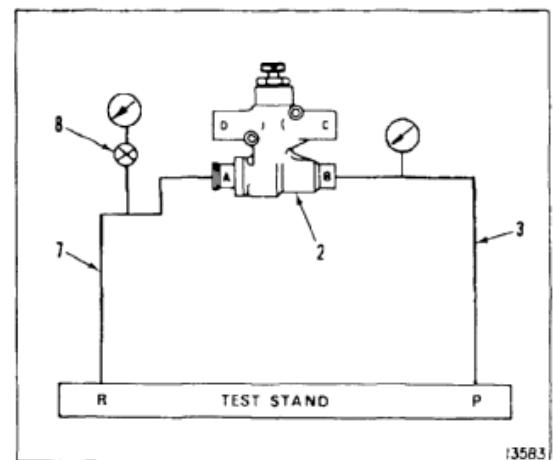

RELIEF FUNCTION AND BLEED LEAKAGE

18. Disconnect pressure hose from port B of valve (2).
19. Disconnect return hose from port A.
20. Install test stand pressure hose (1) at port A.
21. Install test stand return hose (7) at port B.
22. Place graduate beaker (9) below shutoff valve (10) at port B.
23. Open shutoff valve (10) at port B.
24. Slowly increase pressure at port A to **35 psig**. Leakage from port B shall be **20 cc per minute**.
25. Increase pressure at port A until port B flows at **100 cc per minute**. Cracking pressure at port A shall be **160 psig** minimum.
26. Increase pressure at port A until port B flows at **1.0 gpm**. Rated flow pressure at port A shall be **200 psig** maximum.
27. Reduce pressure to port A until flow at port B is **100 cc per minute**. Reseat pressure shall be **160 psig** minimum.
28. Port A bleed leakage shall be **20 cc per minute**.

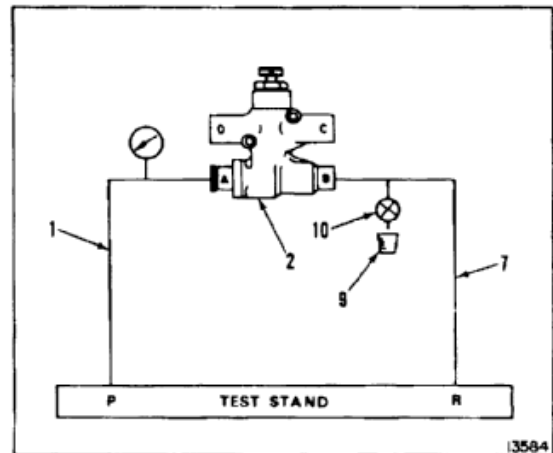

SHUTOFF FUNCTION, LEAKAGE, AND BLEED RATE

29. Connect test stand pressure hose (11) at port C of valve (2).
30. Connect test stand return hose (12) at port D.
31. Bleed all air from test setup solenoid valve (13) and pressure line (1) to **0 to 200 psig** gage (14).
32. Apply and maintain **3000 psig** pressure at port C with port D metered at **1.2 gpm**.
33. Apply increasing pressure to port A with port B open until valve (2) fully disconnects port D from port C.
34. Port D shall be fully disconnected from port C at **35 to 65 psig**.
35. Port C to D leakage shall not exceed **10 cc**.
36. Increase pressure to port A. Close valve to **200 psig** gage (14) and energize (close) solenoid valve (13).
37. Measure time in seconds from the moment solenoid valve (13) is energized until port D is fully reconnected to port C.
38. Port D shall be fully reconnected to port C in **3.0 seconds** maximum after closing of solenoid valve (13).

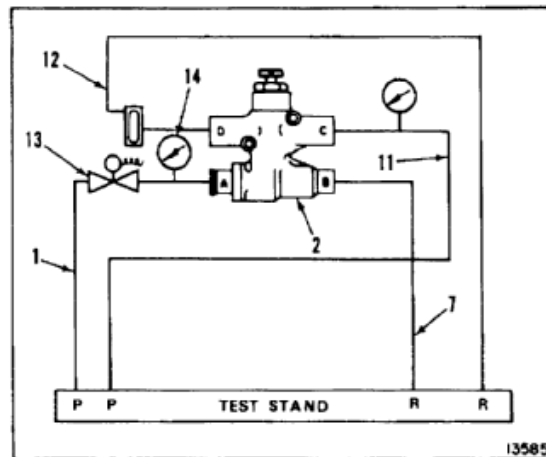

MANUAL OVERRIDE FUNCTION

39. Apply and maintain **60 to 65 psig** pressure at port A of valve (2) with port B open to return and solenoid valve (13) de-energized (open).
40. Apply **50 psig** pressure at port C.
41. Depress and then release manual override button (15). When manual override button is depressed, port C and D shall immediately be connected. When released, port C and D shall immediately be disconnected.
42. Measure the force in pounds required on the manual override button to shift from closed to fully open position. Force required to actuate manual override button shall not vary over **50 percent** at any pressure.
43. Repeat steps 37 thru 40 at **500, 1500, and 3000 psig** pressure.
44. Remove hoses (1), (7), (11), and (12). Remove valve (13) and gage (14). Install pressure caps on ports A, B, C, and D.

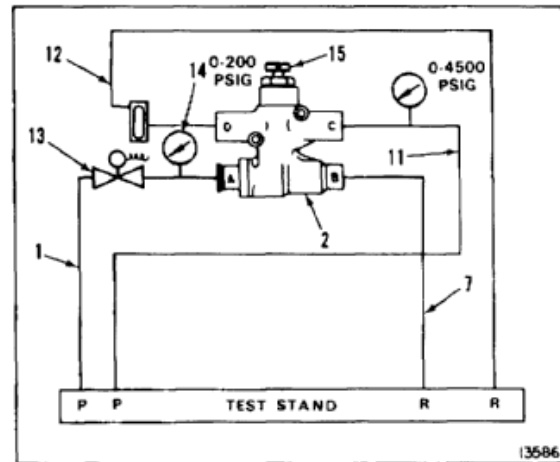
**FOLLOW-ON MAINTENANCE:**

None

END OF TASK

INITIAL SETUP

Applicable Configurations:

All

Tools:

Aircraft Mechanic's Tool Kit, NSN 5180-00-323-4692

Materials:

None

Parts:

Preformed Packings

Personnel Required:

Medium Helicopter Repairer
Inspector

References:

TM 55-1520-240-23P

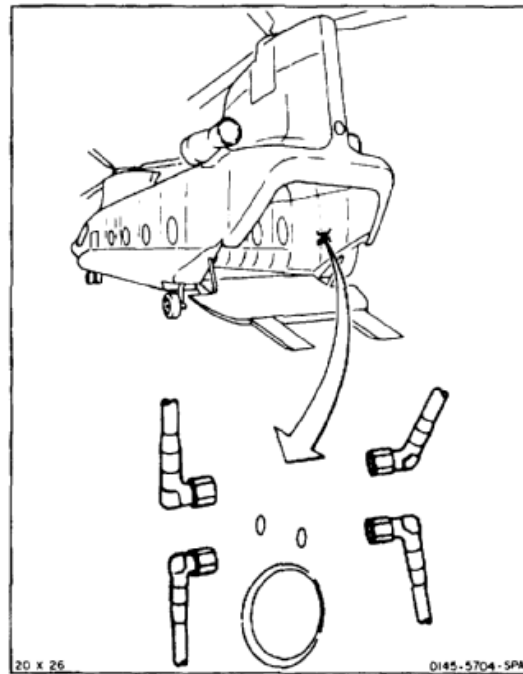

1. Install four packings (1) and nipples (2) in valve (3).

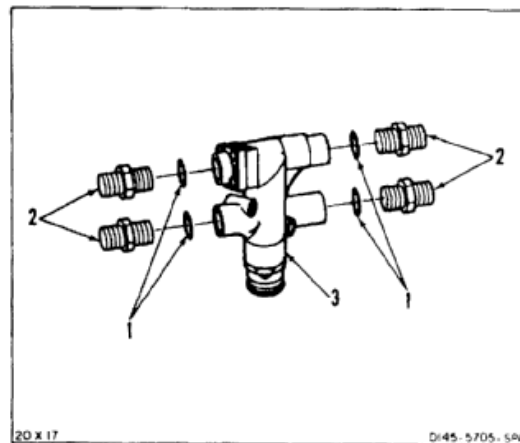

7-284 INSTALL CARGO DOOR PRESSURE ACTUATED VALVE (Continued)

7-284

2. Align two spacers (4) between valve (3) and structure (5). Install two bolts (6), four washers (7), and two nuts (8).
3. Connect four hydraulic tubes (9) to valve (3). Remove tags.

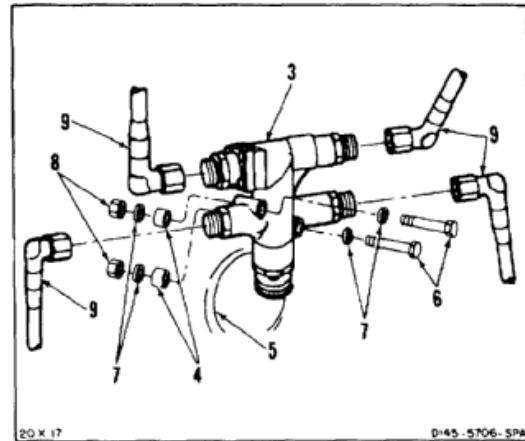
INSPECT**FOLLOW-ON MAINTENANCE:**

- Bleed the utility hydraulic system (Task 7-339).
- Perform cargo ramp operational check (TM 55-1520-240-T).
- Close ramp (TM 55-1520-240-T).

END OF TASK

INITIAL SETUP

Applicable Configurations:

All

Tools:

Aircraft Mechanic's Tool Kit, NSN 5180-00-323-4692
Open-End Wrench, 1 Inch

Materials:

Cloths (E135)
Paper Tags (E264)
Gloves (E186)

Personnel Required:

Medium Helicopter Repairer (2)

Equipment Condition:

Battery Disconnected (Task 1-39)
Electrical Power Off
Hydraulic Power Off
Utility Hydraulic System Depressurized (Task 7-135.1)
Cargo Ramp Fully Down (TM 55-1520-240-T)
Cargo Ramp Panel Removed (Task 2-238)

General Safety Instructions:**WARNING**

Hydraulic fluid (E199) is toxic. It can irritate skin and cause burns. Avoid inhaling. Use only with adequate ventilation. Avoid contact with skin, eyes, or clothing. In case of contact, immediately flush skin or eyes with water for at least **15 minutes**. Get medical attention for eyes.

WARNING

Hydraulic fluid ejected under pressure can cause injury to personnel. Hydraulic fluid sprayed into the air is a fire hazard.

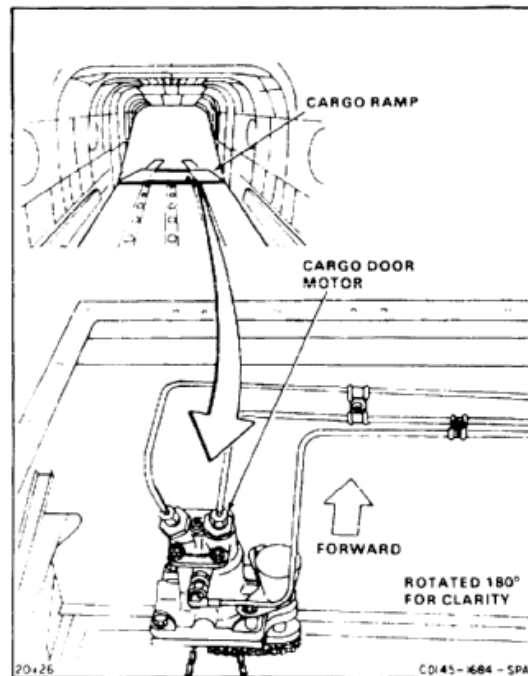

7-285 REMOVE CARGO DOOR MOTOR (ACTUATOR) (Continued)

7-285

1. Tag and disconnect three hydraulic tubes (1). Use cloth (E135) for spilled fluid. Use gloves (E186).

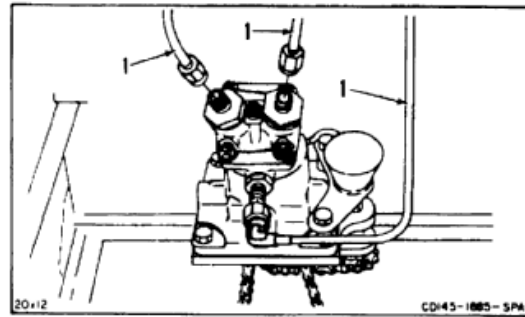

2. Remove two reducers (2) and packings (3).
3. Remove nipple (4) and packing (5).

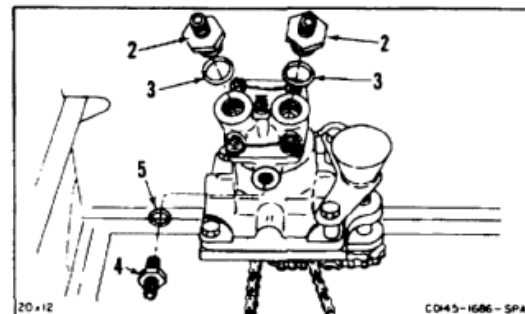

4. Remove two bolts (6) and washers (7).
5. Remove two bolts (8), washers (9), and spacers (10). Remove guide (11).
6. Remove motor (actuator) (12) from spline (13).

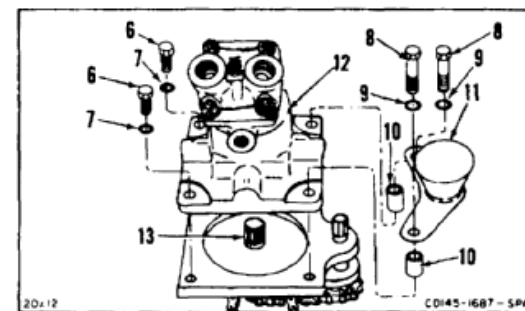
**FOLLOW-ON MAINTENANCE:**

None

END OF TASK

7-1067

INITIAL SETUP

Applicable Configurations:

All

Tools:

Hydraulics Repairer's Tool Kit, NSN
5180-00-323-4891
Steel Rod, 1/16 Inch X 3 Inches (2)
Steel Rod, 1/4 Inch X 3 Inches
Vise, Soft Jaw

Materials:

None

Personnel Required:

Aircraft Pneudraulics Repairer (2)
Inspector

Equipment Condition:

Off Helicopter Task

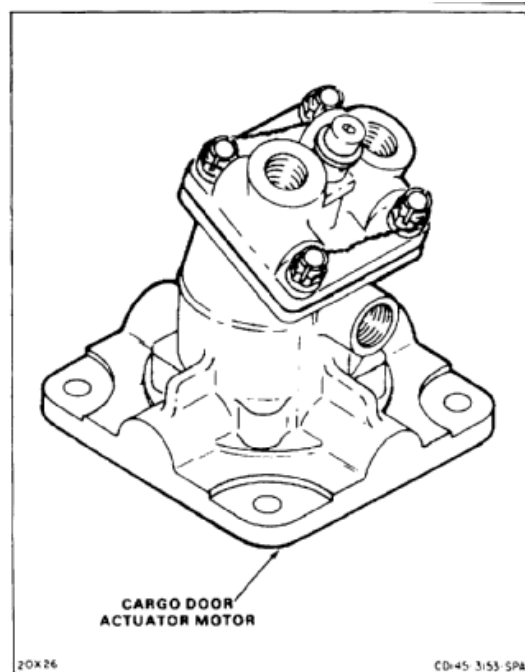
**NOTE**

During disassembly, all parts shall be inspected for obvious damage (Task 7-1.1).

1. Clamp actuator motor (1) in vise (2). Use soft jaw vise.
2. Insert two **1/16 inch** rods (3) through notches in retainer (4) into groove of shaft (5).
3. Turn screw (6) counterclockwise while holding two rods (3).
4. Remove screw (6), washer (7), rods (3), and retainer (4) from shaft (5).

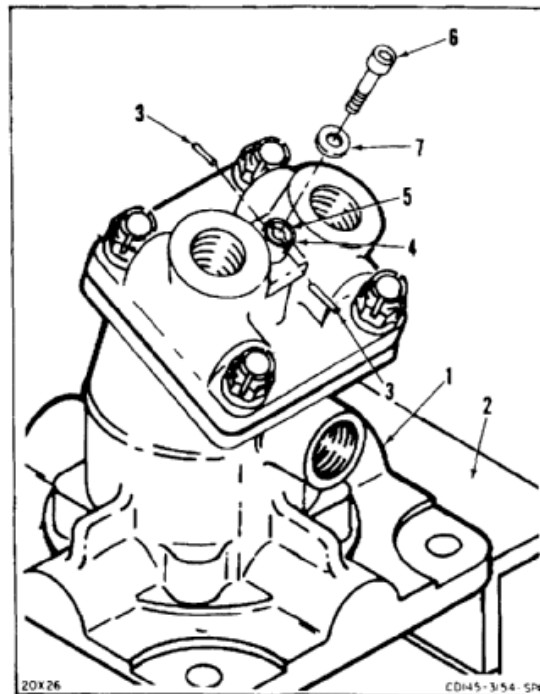

5. Install washer (7) and screw (6) on shaft (5).
6. Pull upward on screw (6) and washer (7) and remove retaining ring (8).
7. Remove screw (6) and washer (7) from shaft (5).

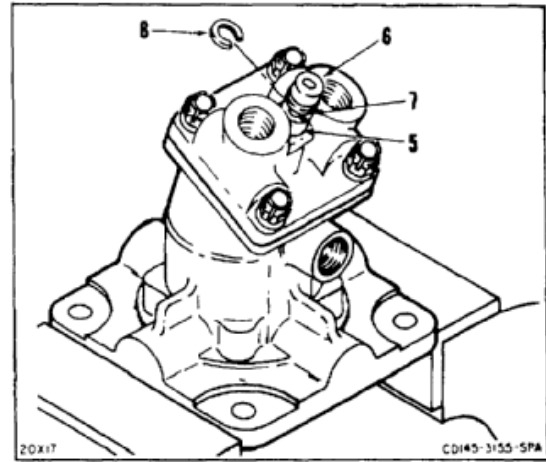

8. Remove lockwire and four nuts (9) from valve head (10).

NOTE

Do not remove shaft with valve head.

9. Push down on shaft (5) with **1/4 inch** rod (11) and remove valve head (10) from housing (12).

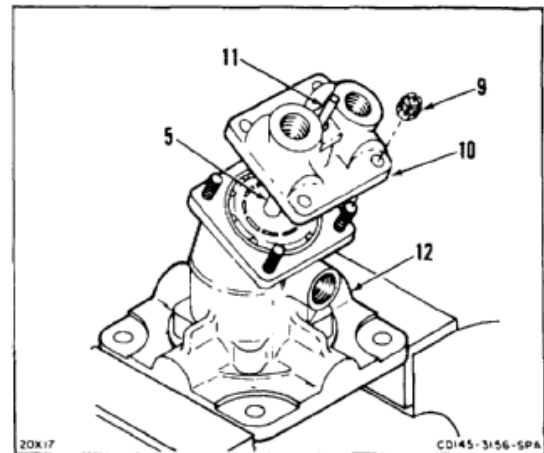

10. Remove packing (13) from shaft (5).
11. Remove packing (14) from housing (12).
12. Remove motor (1) from vise (2).

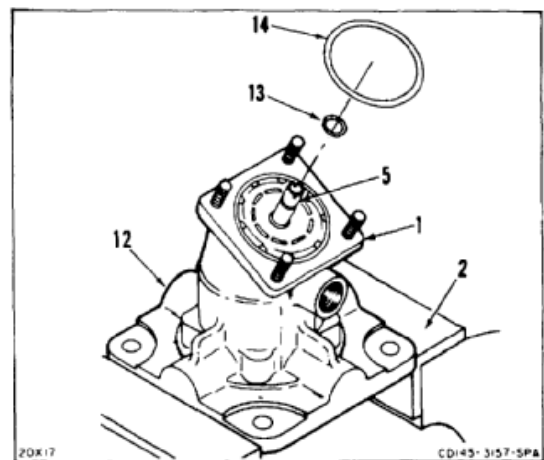

FOLLOW-ON MAINTENANCE:

None

END OF TASK

INITIAL SETUP

Applicable Configurations:

All

Tools:

Hydraulics Repairer's Tool Kit, NSN
5180-00-323-4891
Torque Wrench, 30 to 150 Inch-Pounds
Steel Rod, 1/16 Inch X 3 Inches (2)
Vise, Soft Jaw

Materials:

Lockwire (E231)

Parts:

Preformed Packings

Personnel Required:

Aircraft Pneudraulics Repairer (2)
Inspector

References:

TM 55-1520-240-23P

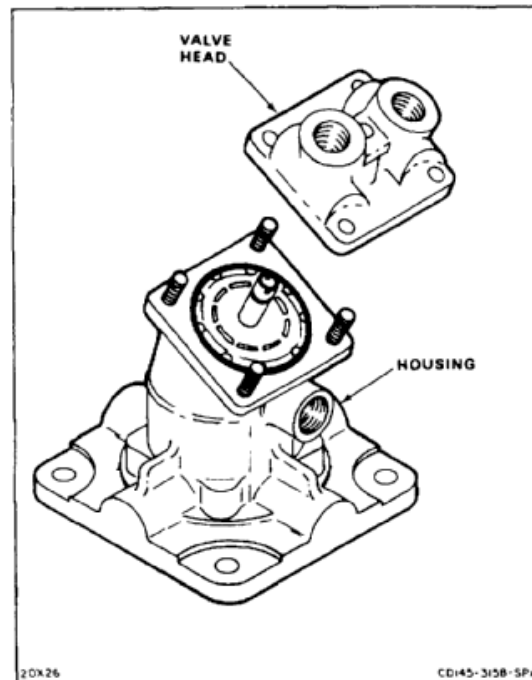

1. Clamp actuator motor (1) in vise (2). Use soft jaw vise.
2. Install packing (3) on shaft (4).
3. Install packing (5) in groove in housing (6).

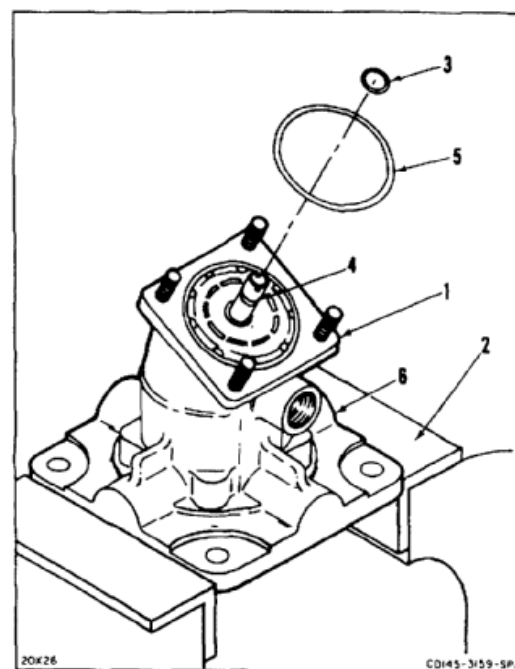

4. Install valve head (7) and four nuts (8) on studs (9).
5. Torque nuts (8) to **75 inch-pounds**.

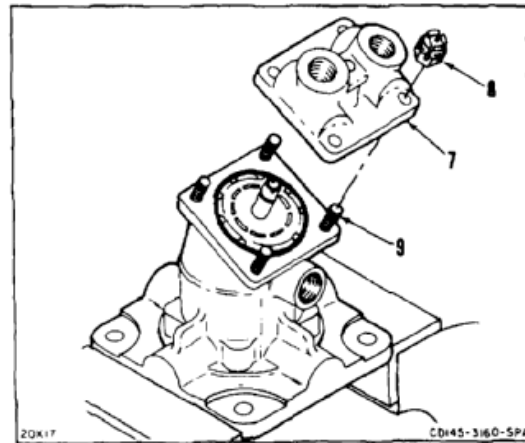

6. Temporarily install screw (10) and washer (11) on shaft (4).
7. Pull up screw (10) and washer (11) and install retaining ring (12) on shaft (4).
8. Remove screw (10) and washer (11).

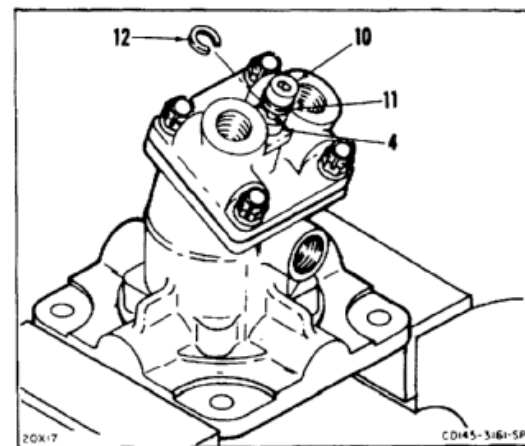

9. Install retainer (13) on shaft (4) so that notches in retainer align with grooves in shaft.
10. Install washer (11) and screw (10).
11. Insert two rods (14) through notches in retainer (13) into grooves in shaft (4).
12. Hold rods (14) and tighten screw (10).
13. Remove rods (14).

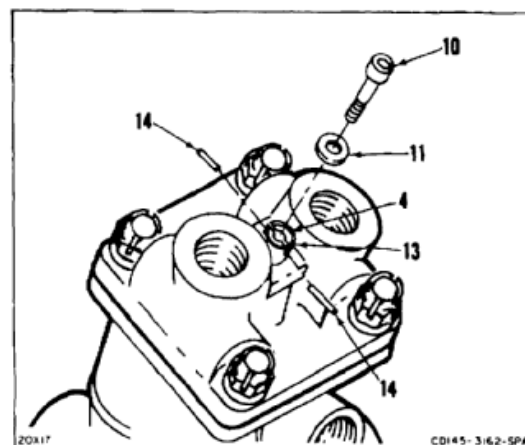

14. Lockwire four nuts (8). Use lockwire (E231).
15. Remove motor (1) from vise (2).

INSPECT**FOLLOW-ON MAINTENANCE:**

Test cargo door actuator motor (Task 7-288).

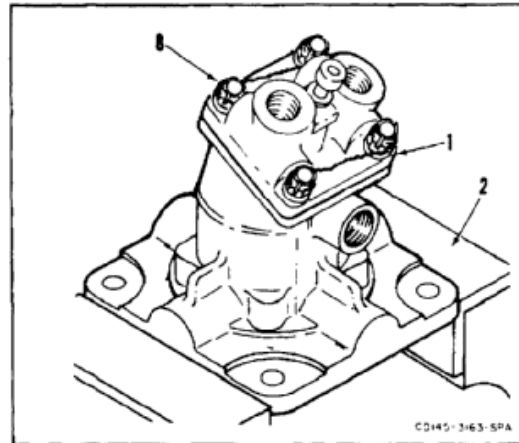

END OF TASK

7-1072

INITIAL SETUP

Applicable Configurations:

All

Tools:

Hydraulic Repairer's Tool Kit, NSN 5180-00-323-4891
 Hydraulic Test Stand
 Pressure Caps
 Flexible Hose, 1/4 Inch, 0 to 4500 psi
 Stop Watch

Materials:

None

Personnel Required:

Aircraft Pneudraulics Repairer
 Inspector

Equipment Condition:

Off Helicopter Task

General Safety Instructions:**WARNING**

Hydraulic fluid (E199) is toxic. It can irritate skin and cause burns. Avoid inhaling. Use only with adequate ventilation. Avoid contact with skin, eyes, or clothing. In case of contact, immediately flush skin or eyes with water for at least **15 minutes**. Get medical attention for eyes.

WARNING

Hydraulic fluid ejected under pressure can cause injury to personnel. Hydraulic fluid sprayed into the air is a fire hazard.

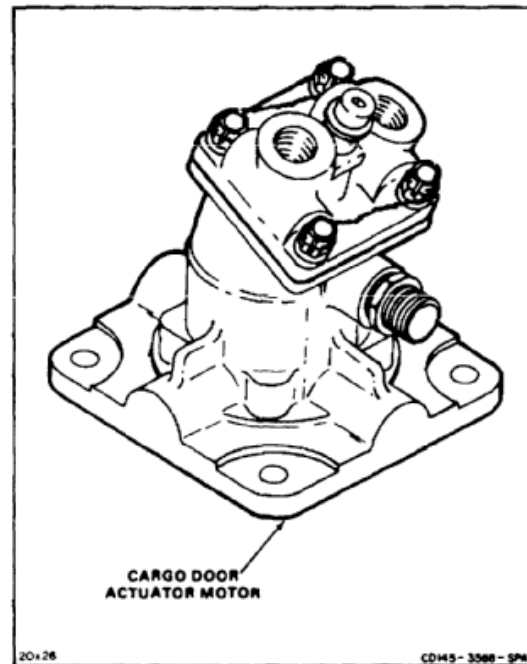

1. Install pressure caps in ports (1 and 2) of actuator motor (3).
2. Connect test stand pressure hose (4) to case drain port (5).
3. Apply **150 psi** hydraulic pressure to case drain port (5) for **2 minutes**.
4. Check actuator motor (3) for external leaks. There shall be no external leaks except at seal (6). Leak at seal shall be less than **5 drops in 10 minutes**.

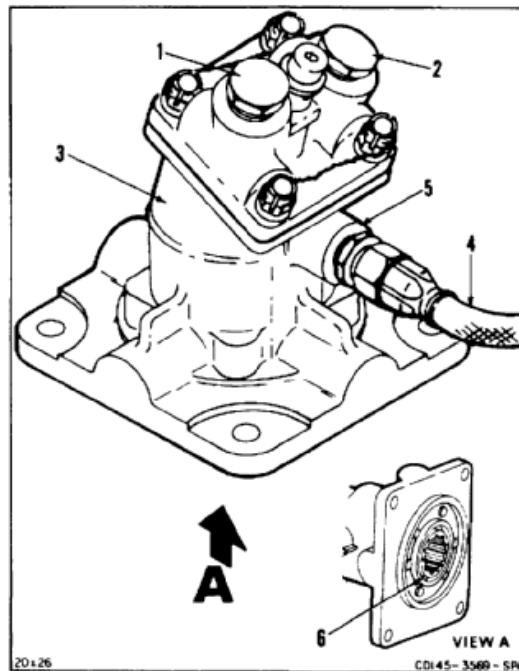

5. Reduce pressure to **0 psi**.
6. Disconnect pressure hose (4) from port (5).
7. Remove pressure caps from ports (1 and 2).

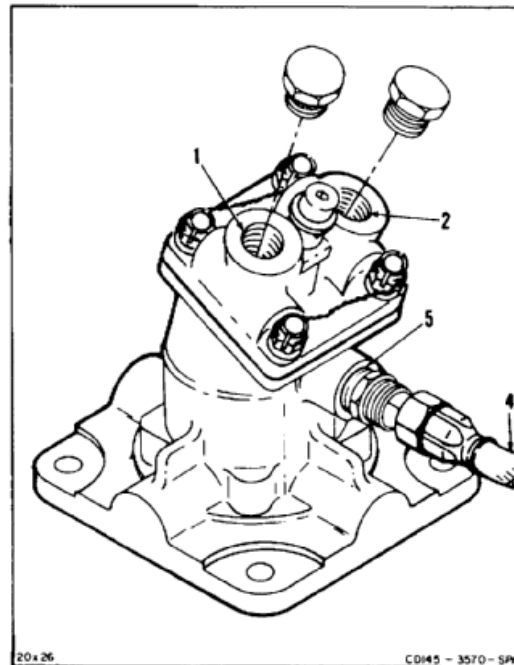
**FOLLOW-ON MAINTENANCE:**

None

END OF TASK

7-1074

INITIAL SETUP

Applicable Configurations:

All

Tools:

Aircraft Mechanic's Tool Kit, NSN 51 80-00-323-4692
 Box Wrench, 1 Inch

Materials:

Cloth (E135)
 Hydraulic Fluid (E199)
 Grease (E189)
 Gloves (E186)

Parts:

Preformed Packing
 Nonmetallic Washers

Personnel Required:

Medium Helicopter Repairer (2)
 Inspector

References:

TM 55-1520-240-23P

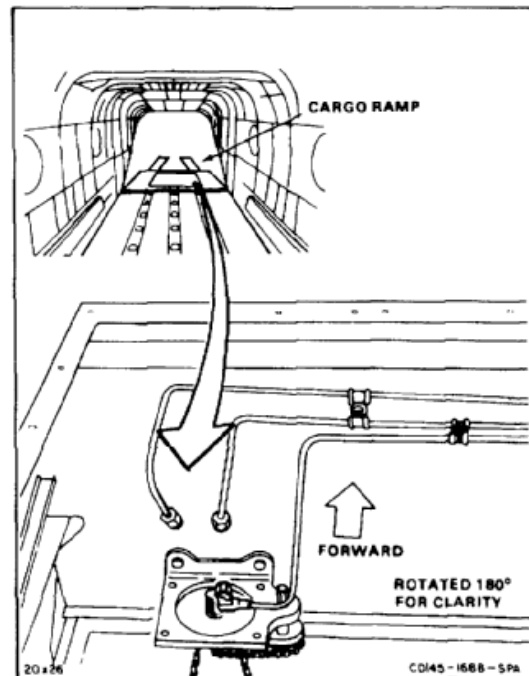

1. Apply grease (E189) to spline (1).
2. Fill motor (actuator) (2) through port (3) with hydraulic fluid (E199). Use cloth (E135) for spilled fluid. Use gloves (E186).
3. Position motor (2) over spline (1) with angled head pointing aft. Lower motor to engage spline (1).
4. Position guide (4) as shown. Install two washers (5), spacers (6), and bolts (7).
5. Install two washers (8) and bolts (9).

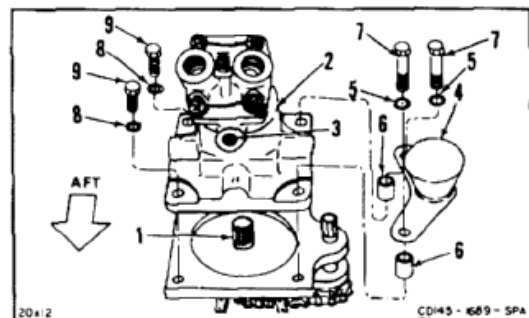

6. Install two packings (10) and reducers (11). Use **1 inch** box wrench.
7. Install packing (12) and nipple (13).
8. Connect three tubes (14). Remove tags.

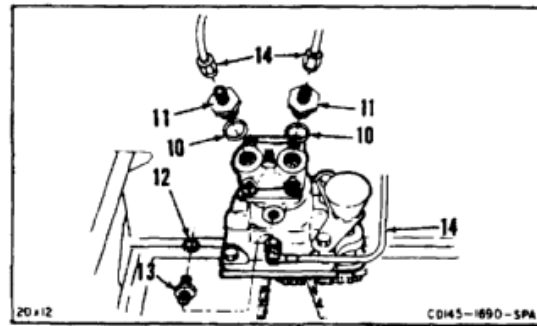
**INSPECT****FOLLOW-ON MAINTENANCE:**

- Bleed utility hydraulic system (Task 7-339).
- Check operation of cargo door motor (TM 55-1520-240-T).
- Replace cargo ramp panel (Task 2-244).

END OF TASK

7-1076

DESCRIPTION

A power steering system is fitted to the aft right landing gear. The system uses electrical control and hydraulic power to steer the helicopter during ground maneuvers. When power steering is not being used, swivel locks can be engaged to hold the aft wheels in a trailing position. The locks are operated by the same electrical and hydraulic system as the power steering.

The system consists of a control module, a control switch, a swivel lock switch, a control box, and actuators for the power steering and the swivel locks.

The module is located on the right side of the cabin at sta. 485. It contains an accumulator, two solenoid valves, and a check valve. The accumulator reduces surges and ensures a constant pressure when high

demands are placed on the system. The valves control fluid flow to the swivel lock actuators and the power steering actuator. The check valve prevents backflow between the two solenoid valves.

A swivel lock actuator is on each aft landing gear. The actuators direct hydraulic pressure to lock and unlock the swivel locks. A power steering actuator is mounted on top of the aft right gear. All three actuators are engaged and disengaged by a switch on the power steering control box in the cockpit center console.

The entire system can be isolated from the rest of the utility hydraulic system by a solenoid valve in the utility pressure control module. The normally open valve is closed by a switch on the overhead hydraulic control panel in the cockpit.

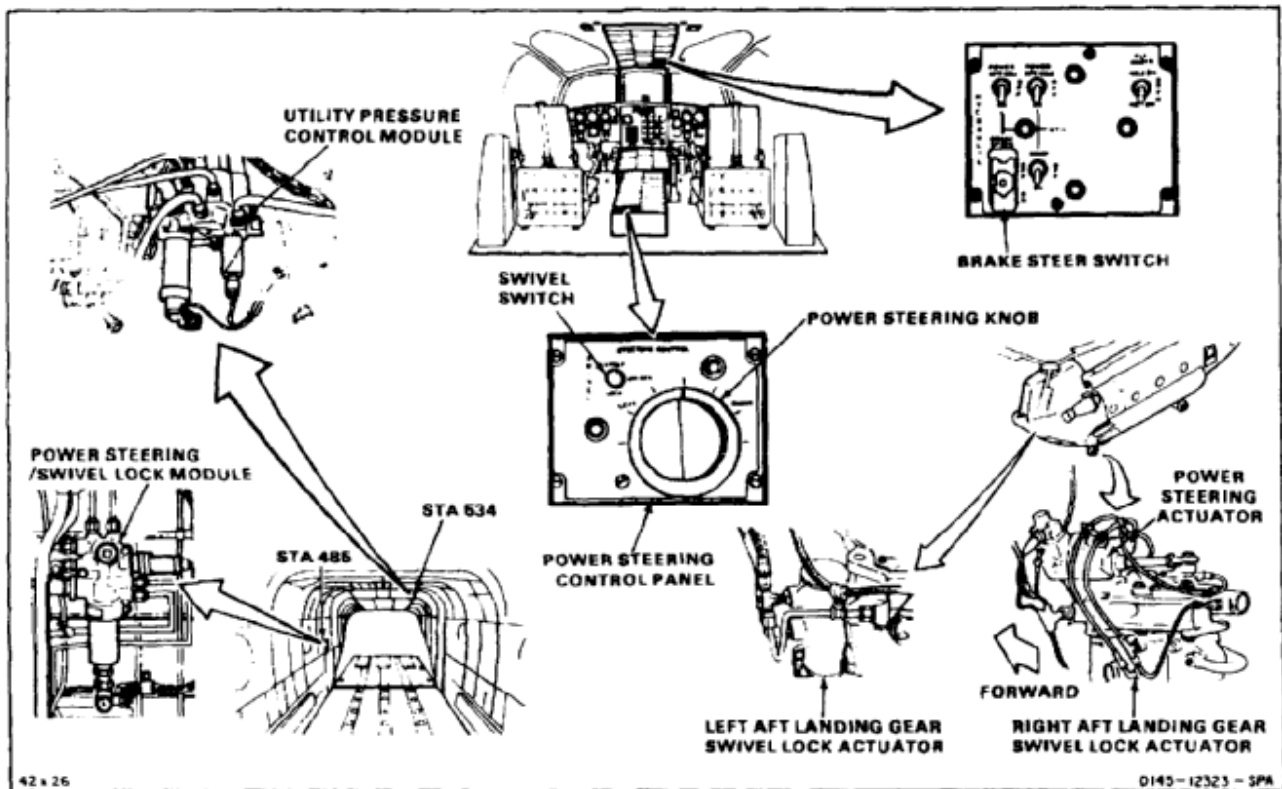

When the switch is set to UNLOCK, the control valve on the module is de-energized. Hydraulic pressure is removed from the upper port of the actuator and applied to the lower port. The piston within the swivel housing is moved upward, releasing the swivel lock from the detent and allowing the wheel to swivel freely.

Setting the switch to UNLOCK also disengages the heading hold circuitry in both AFCS computers to allow the helicopter to be steered in different directions. The

swivel locks are spring-loaded up. Therefore, when the hydraulic system is shut down, the locks are disengaged and the wheel is free to caster.

Power Steering

Setting the SWIVEL switch to STEER applies power to the power steering solenoid valve on the control module, the power steering control box power supply, and an out-of-phase switch on the aft right landing gear.

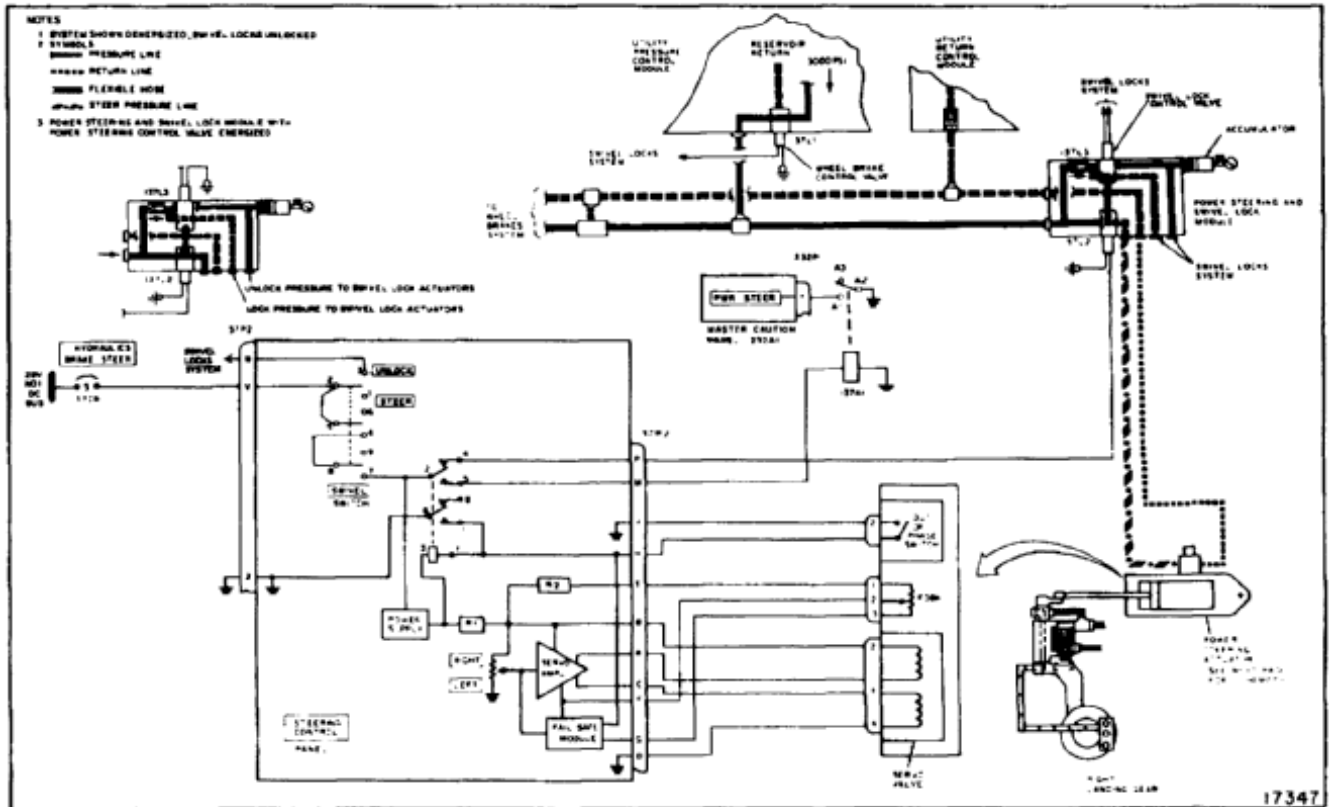

Energizing the solenoid valve on the control module opens it to allow hydraulic pressure to the power steering actuator on the aft right gear. Putting power to the control box power supply energizes a servo valve within the power steering actuator.

Turning the knob on the control box to the left or right produces a command potentiometer signal in a servo amplifier within the box. This generates an output voltage to the servo valve on the actuator. The servo valve responds by routing fluid flow within the actuator to turn the wheel in the selected direction.

A feedback potentiometer on the actuator generates a signal proportional to the degree of wheel swiveling. When the feedback and command potentiometer signals are equal, the servo loop is balanced. The actuator stops and the wheel will halt in the selected position. If the wheel goes beyond a preset limit, the out-of-phase

switch will close, grounding relay 137K1 in the center console. This shuts off hydraulic pressure to the system and lights the PWR STEER light in the master caution panel.

A fail-safe module in the control box monitors the system for shorts and open circuits. If either occurs, the module grounds relay 137K1 in the same manner as the out-of-phase switch does. Hydraulic pressure is shut off and the PWR STEER master caution panel light comes on.

A balance potentiometer within the steering control box allows compensation for variations in servo valve and amplifier performance. Adjustment of this potentiometer permits proper tracking of the wheel and the control knob and ensures that the swivel lock will engage without binding.

END OF TASK

7-1080

INITIAL SETUP

Applicable Configurations:

All

Tools:

Aircraft Mechanic's Tool Kit, NSN 51 80-00-323-4692
Container, 2 Quart

Materials:

Cloths (E135)
Paper Tags (E264)
Gloves (E184.1)

Personnel Required:

Medium Helicopter Repairer

Equipment Condition:

Battery Disconnected (Task 1-39)
Electrical Power Off
Hydraulic Power Off
Utility Hydraulic System Depressurized (Task 7-135.1)
Power Steering/Swivel Lock Accumulator
Depressurized (Task 1-66)
Cargo Ramp Open and Level (TM 55-1520-240-10)

General Safety Instructions:**WARNING**

Hydraulic fluid (E199) is toxic. It can irritate skin and cause burns. Avoid inhaling. Use only with adequate ventilation. Avoid contact with skin, eyes, or clothing. In case of contact, immediately flush skin or eyes with water for at least **15 minutes**. Get medical attention for eyes.

WARNING

Hydraulic fluid ejected under pressure can cause injury to personnel. Hydraulic fluid sprayed into the air is a fire hazard.

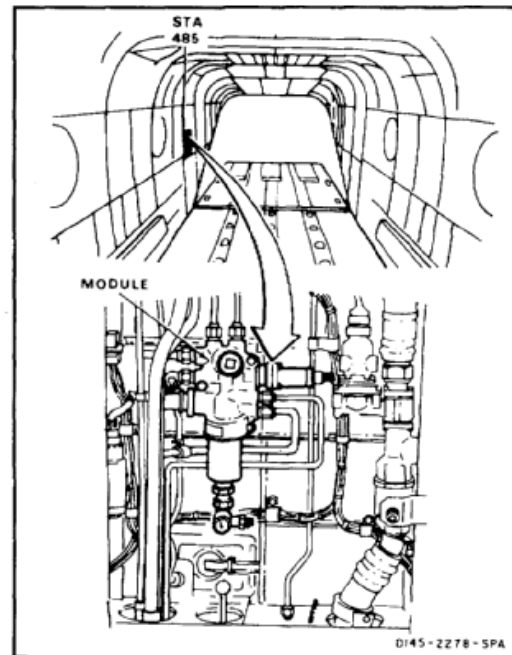

1. Tag and disconnect two connectors (1) from module (2). Use tag (E264).
2. Tag and disconnect six tubes (3) from module (2). Use cloths (E135) and container for spilled fluid. Wear gloves (E184.1). Use tag (E264).
3. Remove three bolts (4) and washers (5) from module (2).
4. Remove module (2).

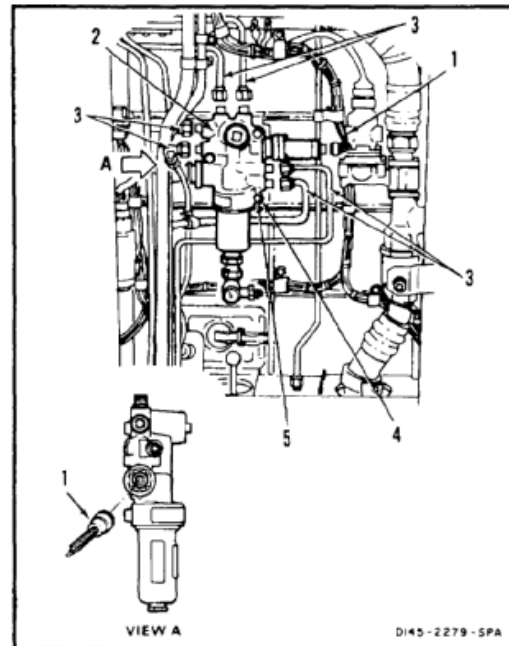
**FOLLOW-ON MAINTENANCE:**

None

END OF TASK

7-1082

INITIAL SETUP

Applicable Configurations:

All

Tools:

Aircraft Mechanic's Tool Kit, NSN 5180-00-323-4692

Torque Wrench, 30 to 150 Inch-Pounds

Torque Wrench, 150 to 750 Inch-Pounds

Materials:

None

Personnel Required:

Medium Helicopter Repairer

Inspector

References:

TM 55-1520-240-23P

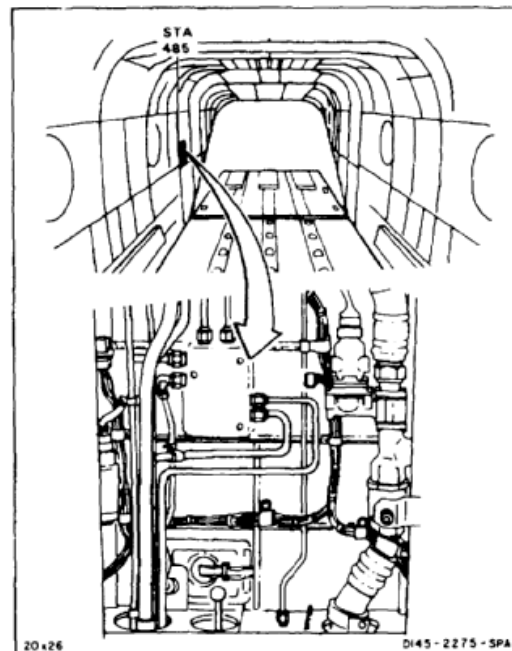

1. Position module (1). Install three bolts (2) and washers (3). Torque bolts (2) to **60 inch-pounds**.
2. Connect tube (4) to RSVR RTN port (5). Remove tag. Tighten tube nut.
3. Connect tube (6) to IN PRES port (7). Remove tag. Tighten tube nut.
4. Connect tube (8) to SWVL UNLOCK port (9). Remove tag. Tighten tube nut.

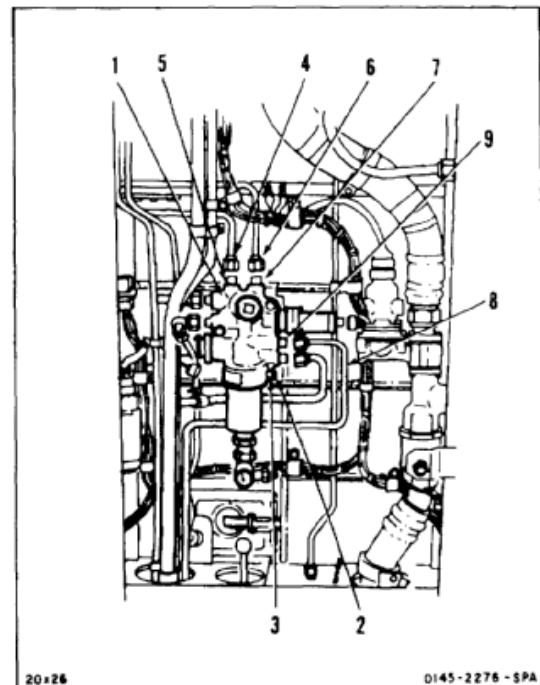

5. Connect tube (10) to SWVL LOCK port (11). Remove tag. Tighten tube nut.
6. Connect tube (12) to PWR STRG PRESS port (13). Remove tag. Tighten tube nut.
7. Connect tube (14) to PWR STRG RTN port (15). Remove tag. Tighten tube nut.
8. Connect connector (16) to PWR STRG V plug (17).
9. Connect connector (18) to SWVL LK V plug (19).
10. Remove all tags.

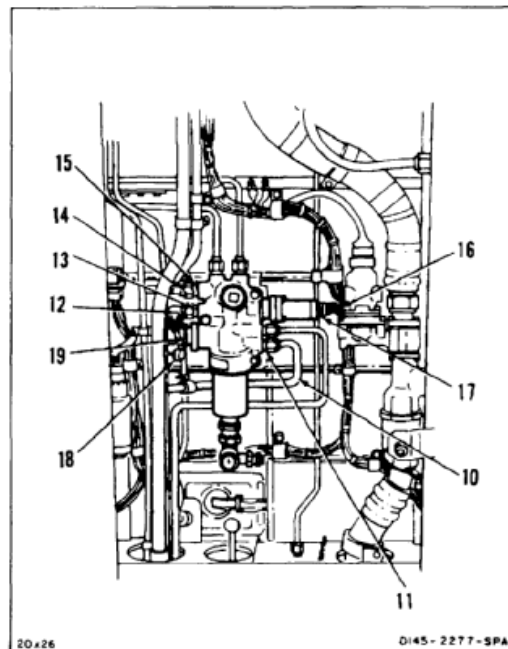
INSPECT**FOLLOW-ON MAINTENANCE:**

- Service accumulator (Task 1-66).
- Service utility hydraulic system (Task 1-59 or 1-62).
- Bleed power steering/swivel lock system (Tasks 7-331 and 7-332).
- Perform operational check (TM 55-1520-240-T).
- Close cargo ramp (TM 55-1520-240-T).

END OF TASK

7-1084

7-293 REMOVE POWER STEERING AND SWIVEL LOCK CONTROL VALVES

7-293

INITIAL SETUP**Applicable Configurations:**

All

Tools:

Aircraft Mechanic's Tool Kit, NSN 5180-00-323-4692
 Open-End Wrench, 1-1/4 Inch
 Container, 2 Quart

Materials:

Cloths (E135)
 Gloves (E186)

Personnel Required:

Medium Helicopter Repairer

Equipment Condition:

Battery Disconnected (Task 1-39)
 Electrical Power Off
 Hydraulic Power Off
 Utility Hydraulic System Depressurized (Task 7-135.1)
 Power Steering/Swivel Lock Accumulator
 Depressurized (Task 1-66)
 Cargo Ramp Open and Level (TM 55-1520-240-T)

General Safety Instructions:**WARNING**

Hydraulic fluid (E199) is toxic. It can irritate skin and cause burns. Avoid inhaling. Use only with adequate ventilation. Avoid contact with skin, eyes, or clothing. In case of contact, immediately flush skin or eyes with water for at least **15 minutes**. Get medical attention for eyes.

WARNING

Hydraulic fluid ejected under pressure can cause injury to personnel. Hydraulic fluid sprayed into the air is a fire hazard.

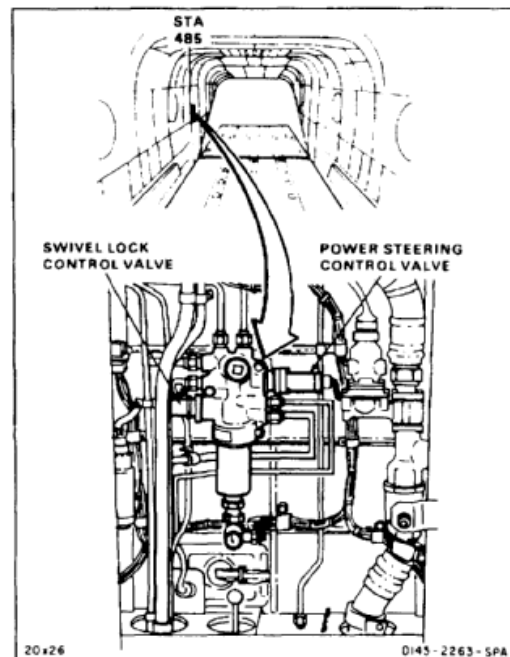

NOTE

Procedure to remove power steering or swivel lock control valves is same. Power steering control valve is shown here.

1. Disconnect connector (1) from valve (2).
2. Remove lockwire from valve (2).
3. Remove valve (2), three packings (3), and six retainers (4) from PWR STRG V port (5). Use container and cloths (E135) for spilled fluid. Use gloves (E186).

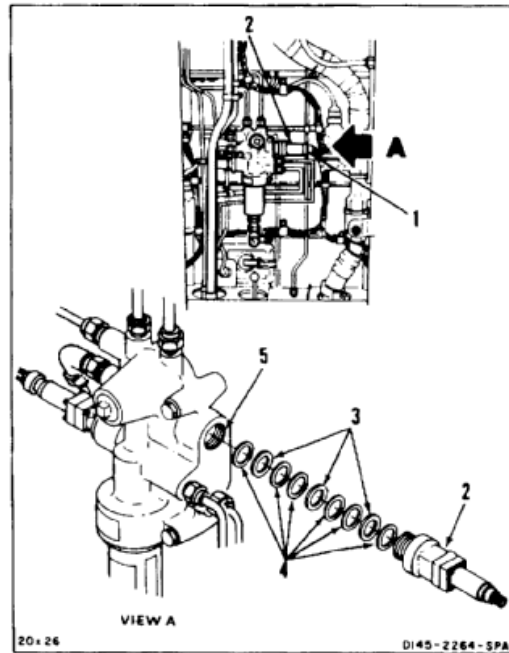
**FOLLOW-ON MAINTENANCE:**

None

END OF TASK

7-1086

INITIAL SETUP

Applicable Configurations:

All

Tools:

Aircraft Mechanic's Tool Kit, NSN 1580-00-323-4692
Open-End Wrench, 1-1/4 Inch

Materials:

Cloths (E135)
Lockwire (E231)

Parts:

Preformed Packings
Retainers

Personnel Required:

Medium Helicopter Repairer
Inspector

References:

TM 55-1520-240-23P

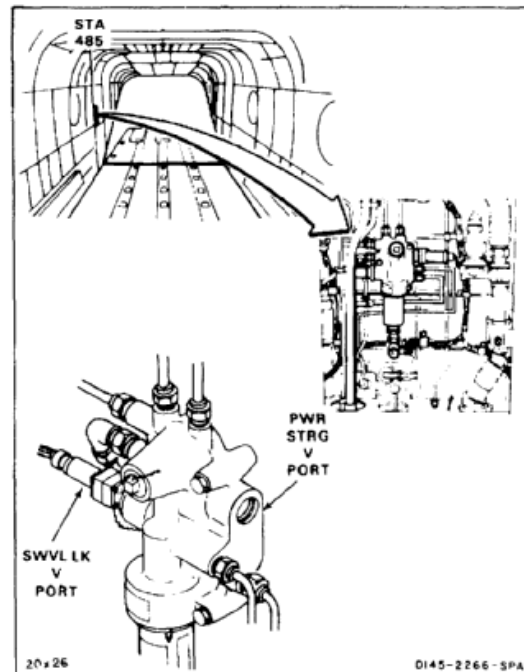
**NOTE**

Procedure to install power steering or swivel lock control valve is same. Power steering control valve is shown.

1. Install valve (1), six retainers (2), and packings (3) in PWR STRG V port (4). Use cloths (E135) for spilled fluid.
2. Lockwire valve (1). Use lockwire (E231).
3. Connect connector (5) to valve (1).

INSPECT**FOLLOW-ON MAINTENANCE:**

Service accumulator (Task 1-66).
Bleed power steering and swivel lock system (Tasks 7-331 and 7-332).
Perform operational check (TM 55-1520-240-T).
Close cargo ramp (TM 55-1520-240-T).

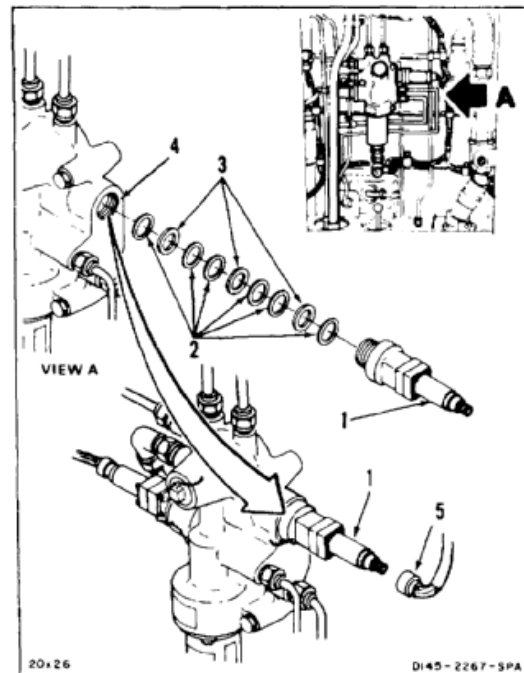

END OF TASK

INITIAL SETUP

Applicable Configurations:

All

Tools:

Aircraft Mechanic's Tool Kit, NSN 5180-00-323-4692
Container, 2 Quart

Materials:

Cloths (E135)
Gloves (E186)

Personnel Required:

Medium Helicopter Repairer

Equipment Condition:

Battery Disconnected (Task 1-39)
Electrical Power Off
Hydraulic Power Off
Utility Hydraulic System Depressurized (Task 7-135.1)
Power Steering/Swivel Lock Accumulator
Depressurized (Task 1-66)
Cargo Ramp Open and Level (TM 55-1520-240-T)

General Safety Instructions:**WARNING**

Hydraulic fluid (E199) is toxic. It can irritate skin and cause burns. Avoid inhaling. Use only with adequate ventilation. Avoid contact with skin, eyes, or clothing. In case of contact, immediately flush skin or eyes with water for at least **15 minutes**. Get medical attention for eyes.

WARNING

Hydraulic fluid ejected under pressure can cause injury to personnel. Hydraulic fluid sprayed into the air is a fire hazard.

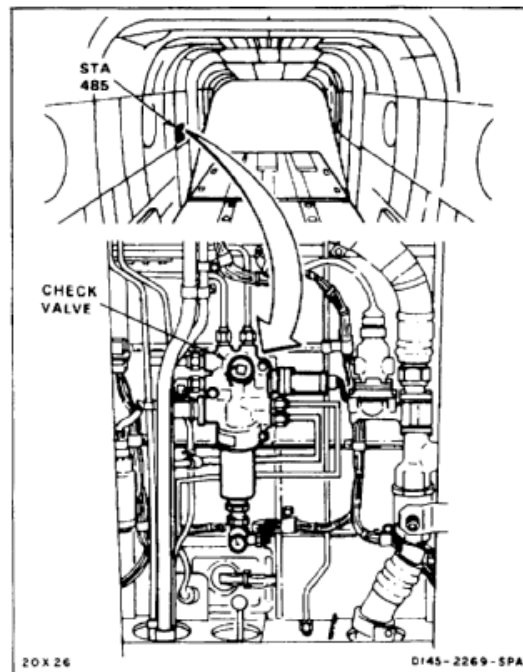

1. Remove lockwire from check valve (1).

NOTE

Valve body is soft aluminum.

2. Remove check valve (1), two packings (2) and four retainers (3) from module (4). Use container and cloths (E135) for spilled fluid. Use gloves (E186).

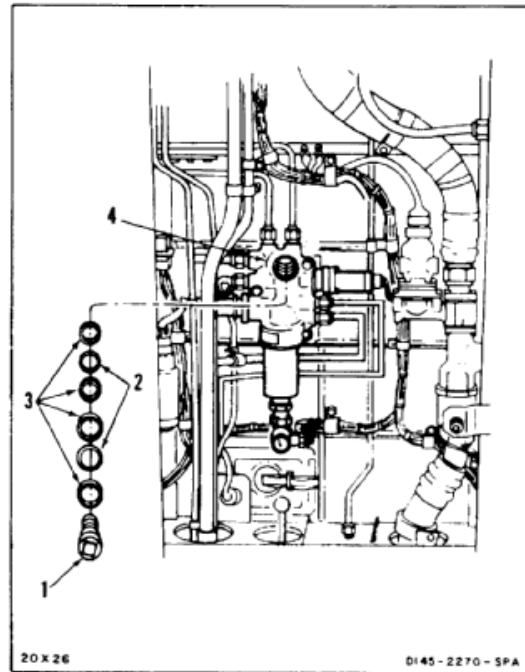

FOLLOW-ON MAINTENANCE:

None

END OF TASK

INITIAL SETUP

Applicable Configurations:

All

Tools:

Aircraft Mechanic's Tool Kit, NSN 5180-00-323-4692

Materials:Cloths (E135)
Lockwire (E231)**Parts:**Preformed Packings
Retainers**Personnel Required:**Medium Helicopter Repairer
Inspector**References:**

TM 55-1520-240-23P

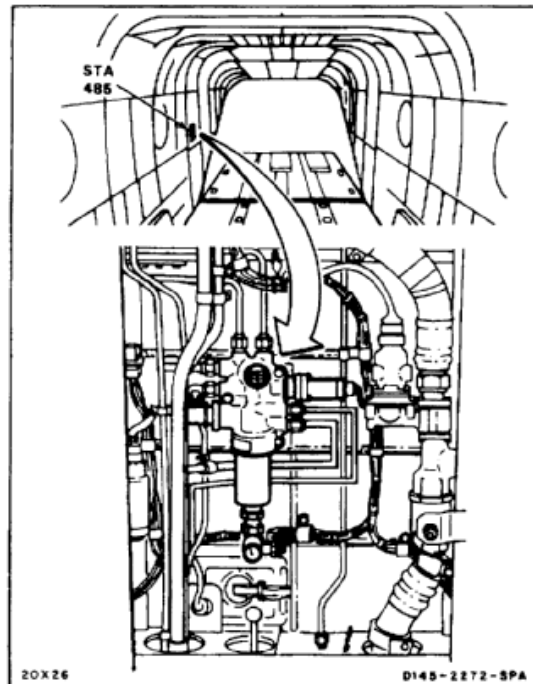

Do not overtighten valve. Valve body damage can occur.

1. Install packing (1) and two retainers (2) on valve (3).
2. Install packing (4) and two retainers (5) on valve (3).
3. Install check valve (3) in port (6). Lockwire valve to module (7). Use lockwire (E231).

INSPECT**FOLLOW-ON MAINTENANCE:**

Service accumulator (Task 1-66).
Bleed power steering and swivel lock system (Tasks 7-331 and 7-332).
Perform operational check (TM 55-1520-240-T).
Close cargo ramp (TM 55-1520-240-T).

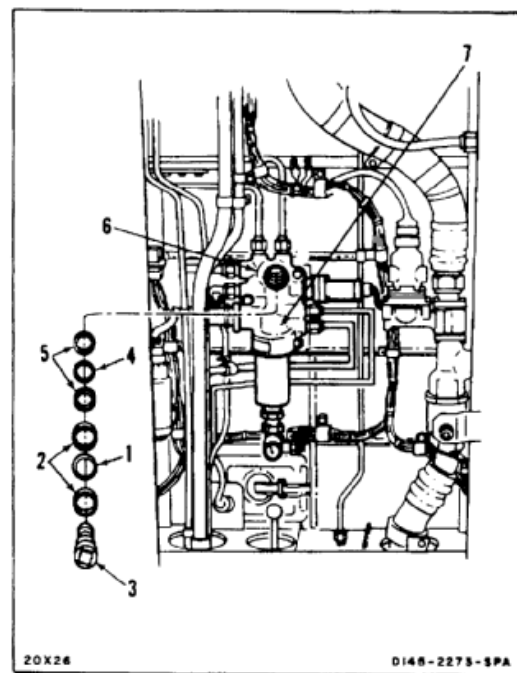

END OF TASK

7-1090

INITIAL SETUP

Applicable Configurations:

All

Tools:

Aircraft Mechanic's Tool Kit, NSN 51 80-00-323-4692
Container, 2 Quart

Materials:

Cloths (E135)
Gloves (E186)

Personnel Required:

Medium Helicopter Repairer

References:

TM 1-1520-253-23

Equipment Condition:

Battery Disconnected (Task 1-39)
Electrical Power Off
Hydraulic Power Off
Utility Hydraulic System Depressurized (Task 7-135.1)
Power Steering/Swivel Lock Accumulator
Depressurized (Task 1-66)
Cargo Ramp Open and Level (TM 55-1520-240-T)

General Safety Instructions:**WARNING**

Hydraulic fluid (E199) is toxic. It can irritate skin and cause burns. Avoid inhaling. Use only with adequate ventilation. Avoid contact with skin, eyes, or clothing. In case of contact, immediately flush skin or eyes with water for at least **15 minutes**. Get medical attention for eyes.

WARNING

Hydraulic fluid ejected under pressure can cause injury to personnel. Hydraulic fluid sprayed into the air is a fire hazard.

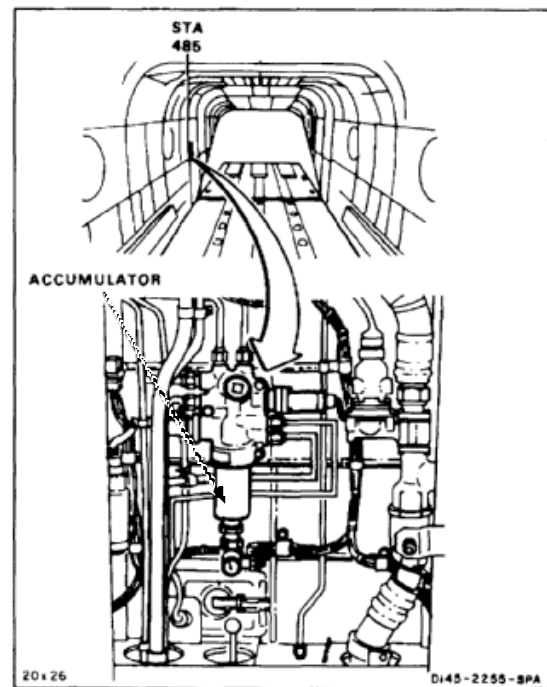

NOTE

If a crack in the accumulator is suspected, refer to TM 1-1520-253-23.

1. Remove lockwire from accumulator (1) and ACCUM port (4).
2. Remove accumulator (1), retainers (2), and packing (3). Use gloves (E186).

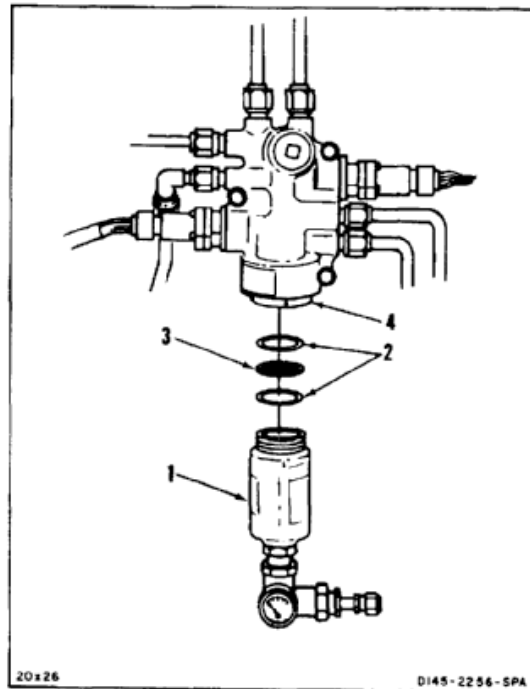

3. Remove lockwire from valve (5) and accumulator (1).
4. Remove tee (6), with valve (5) and gage (7) attached, and packing (8).

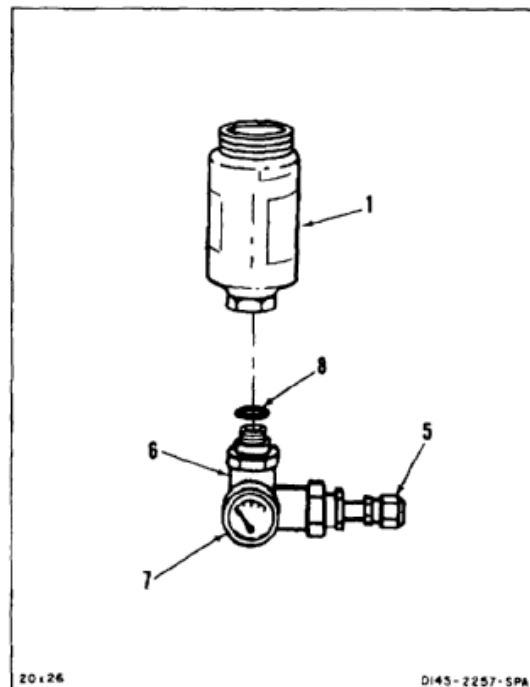

FOLLOW-ON MAINTENANCE:

None

END OF TASK

7-1092

INITIAL SETUP

Applicable Configurations:

All

Tools:

Aircraft Mechanic's Tool Kit, NSN 5180-00-323-4692

Materials:Cloths (E135)
Lockwire (E231)**Parts:**Preformed Packings
Retainers**Personnel Required:**Medium Helicopter Repairer
Inspector**References:**

TM 55-1520-240-23P

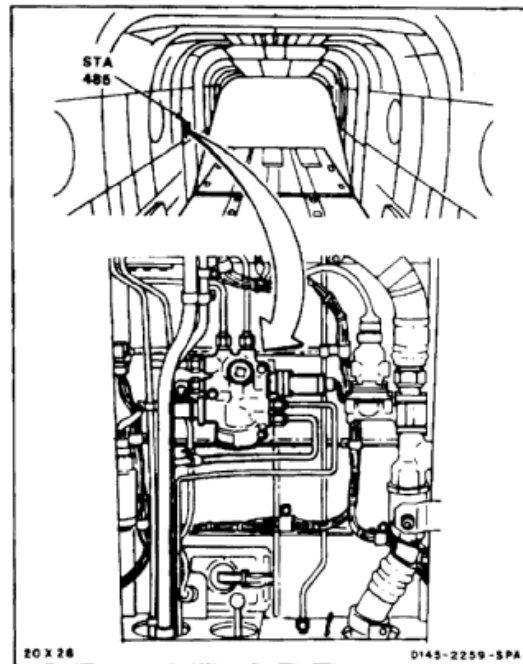

1. Install tee (1), with valve (2) and gage (3) attached, and packing (4) in accumulator (5).
2. Lockwire valve (2) to accumulator (5).

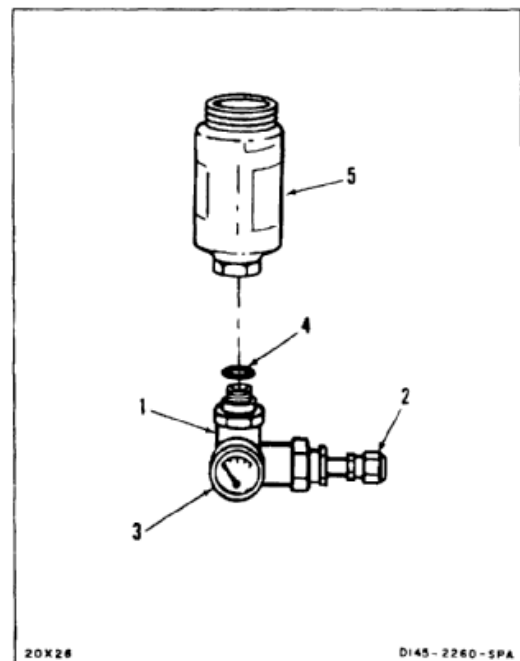

3. Install two retainers (6) and packing (7) in accumulator (5).
4. Install accumulator (5) in ACCUM port (8). Lockwire accumulator. Use lockwire (E231). Use cloths (E135) for spilled fluid.

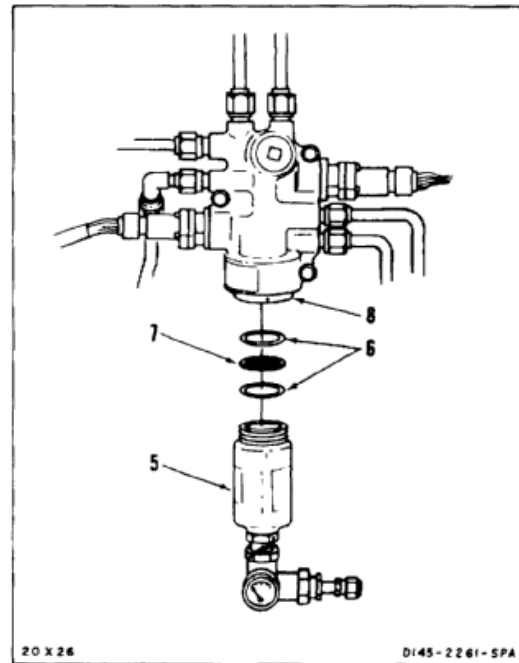
INSPECT**FOLLOW-ON MAINTENANCE:**

- Service accumulator (Task 1-66).
- Service utility hydraulic system (Task 1-59 or 1-62).
- Bleed swivel lock and power steering system (Tasks 7-331 and 7-332).
- Perform operational check (TM 55-1520-240-T).
- Close cargo ramp (TM 55-1520-240-T).

END OF TASK

7-1094

INITIAL SETUP

Applicable Configurations:

All

Tools:

Aircraft Mechanic's Tool Kit, NSN 51 80-00-323-4692
Container, 2 Quart

Materials:

Cloths (E135)
Paper Tags (E264)
Gloves (E186)

Personnel Required:

Medium Helicopter Repairer (2)

Equipment Condition:

Battery Disconnected (Task 1-39)
Electrical Power Off
Hydraulic Power Off
Utility Hydraulic System Depressurized (Task 7-135.1)
Aft Right Landing Gear Access Panels Open (Task 2-2)

General Safety Instructions:**WARNING**

Hydraulic fluid (E199) is toxic. It can irritate skin and cause burns. Avoid inhaling. Use only with adequate ventilation. Avoid contact with skin, eyes, or clothing. In case of contact, immediately flush skin or eyes with water for at least **15 minutes**. Get medical attention for eyes.

WARNING

Hydraulic fluid ejected under pressure can cause injury to personnel. Hydraulic fluid sprayed into the air is a fire hazard.

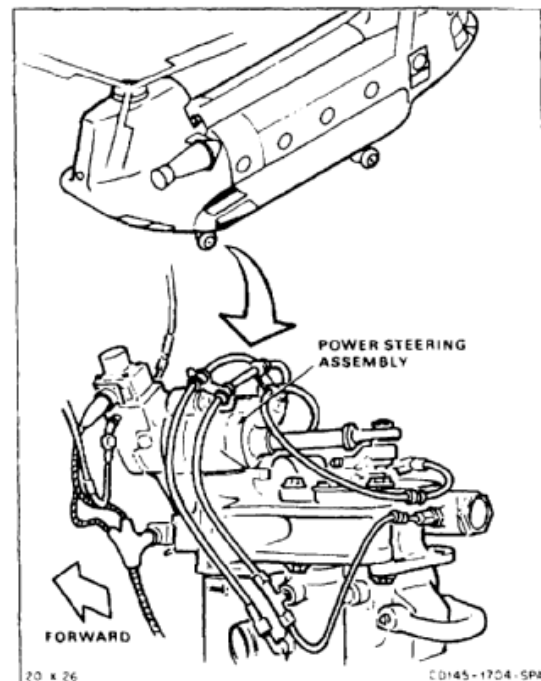

1. Tag and disconnect three electrical plugs (1).
2. Tag and disconnect two hydraulic hoses (2). Use container and cloth (E135) for spilled fluid. Use gloves (E186).

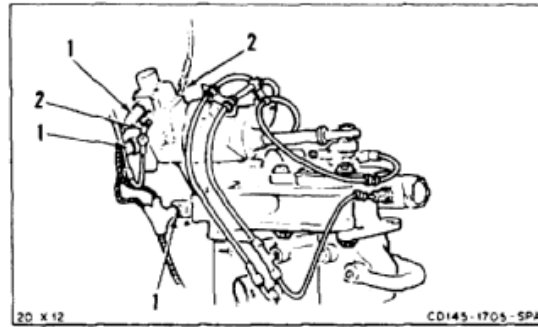

3. Loosen two nuts (3). Remove two elbows (4), packings (5), and washers (6).
4. Remove cotter pin (7), nut (8), and washer (9).

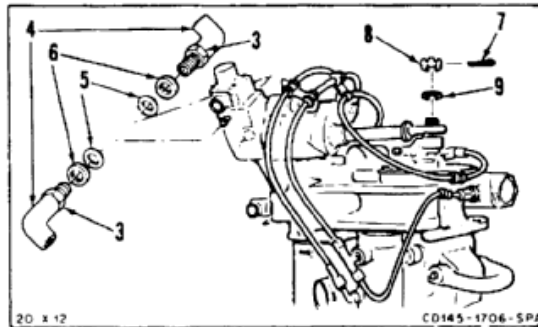

5. Remove two nuts (10) and washers (11).



Do not let power steering assembly fall when attaching bolts are removed. Equipment will be damaged.

6. Have helper support power steering assembly (12). Remove two bolts (13) and washers (14).

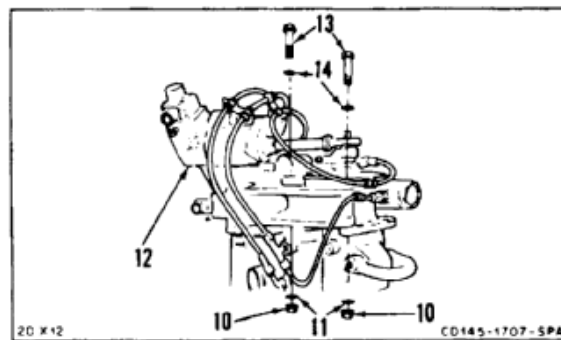

7-299 REMOVE POWER STEERING ASSEMBLY (Continued)**7-299**

7. Slide assembly (12) inboard from housing (15).
8. Lift actuator rod end (16) from stud (17). Remove assembly (12). Leave washer (18) on stud (17).

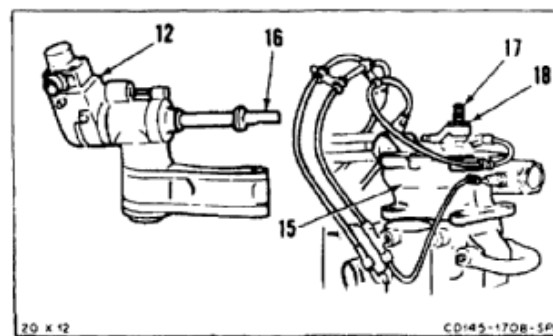
***FOLLOW-ON MAINTENANCE:***

None

END OF TASK

7-1097

INITIAL SETUP

Applicable Configurations:

All

Tools:

Aircraft Mechanic's Tool Kit, NSN 5180-00-323-4692
 Torque Wrench, 0 to 150 Inch-Pounds
 Torque Wrench, 150 to 750 Inch-Pounds

Materials:

Antiseize Compound (E75)

Parts:

Cotter Pin
 Preformed Packing
 Nonmetallic Washer

Personnel Required:

Medium Helicopter Repairer (2)
 Inspector

References:

Task 7-331
 TM 55-1520-240-23P
 TM 55-1520-240-T

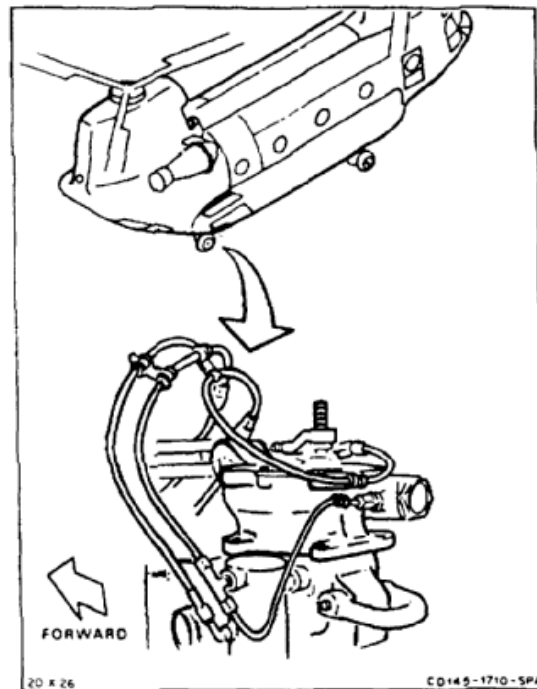

1. Make sure washer (1) is mounted on stud (2).
2. Position assembly (3) as shown. Do not slide assembly lugs (4) between strut lugs (5).
3. Install actuator rod end (6) on stud (2).

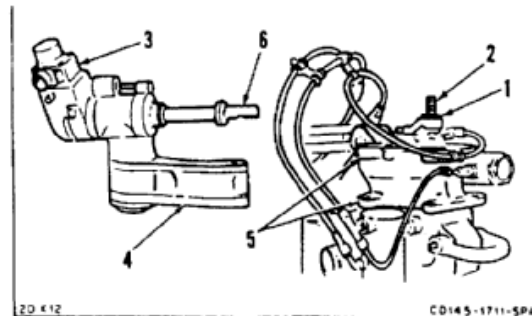

4. Slide assembly (3) to outboard position as shown.

WARNING

Antiseize compound (E75) can form toxic vapors if exposed to flame. Use in well-ventilated area, away from open flame. In case of contact, immediately flush skin or eyes with water for at least **15 minutes**. Get medical attention for eyes.

5. Coat shanks of two bolts (7) with antiseize compound (E75).
 6. Install two washers (8) and bolts (7).
 7. Install two washers (9) and nuts (10). Torque nuts to **850 inch-pounds**.

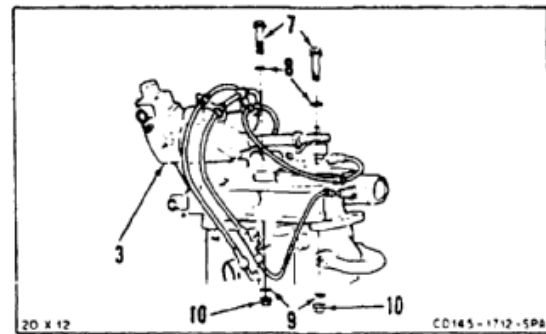

8. Install washer (11) and nut (12) on stud (2).
 9. Tighten nut (12). Make sure washer (1) is free to turn. Leave **0.002 inch** maximum between washer (1) and rod end (6). Do not install cotter pin at this time.

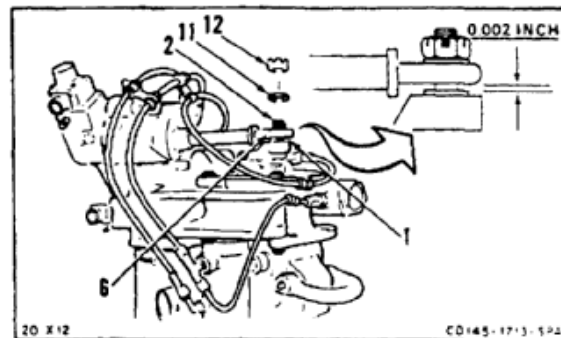

10. Install packing (14) and elbow (15) as shown.
 11. Install packing (17) and elbow (18) as shown.

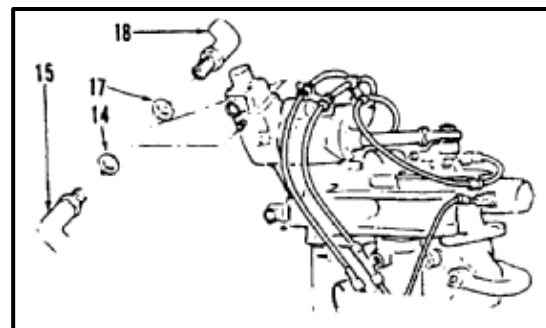

12. Connect two hoses (19). Remove tags.
13. Plug-in three electrical connectors (20). Remove tags.
14. Bleed power steering hydraulic system (Task 7-332).
15. Check operation of power steering assembly (3) (TM 55-1520-240-T).

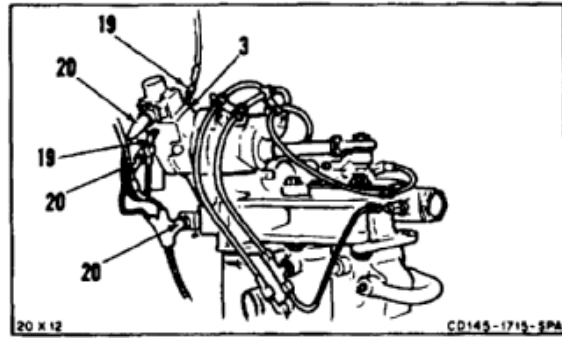

16. Torque nut (12) **290 to 410 inch-pounds**. Install cotter pin (21).

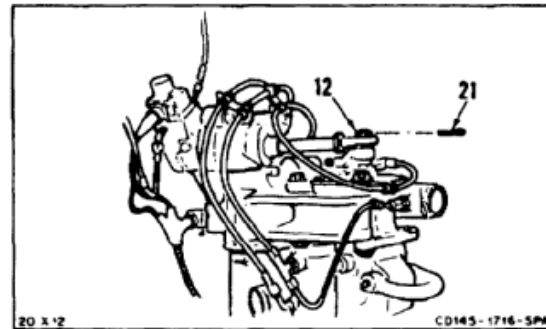
**INSPECT****FOLLOW-ON MAINTENANCE:**

Close aft right landing gear access panel (Task 2-2).

END OF TASK

7-1100

7-301 REMOVE AND INSPECT POWER STEERING ASSEMBLY PRESSURE TUBE (AVIM)

7-301

INITIAL SETUP**Applicable Configurations:**

All

Tools:

Aircraft Mechanic's Tool Kit, NSN 5180-00-323-4692
 Technical Inspection Tool Kit, NSN 5180-00-323-5114

Materials:

None

Personnel Required:

Medium Helicopter Repairer
 Inspector

Equipment Condition:

Off Helicopter Task
 Power Steering Assembly Removed (Task 7-299)

1. Remove lockwire, plug and bleeder (1), and packing (2) from housing (3).

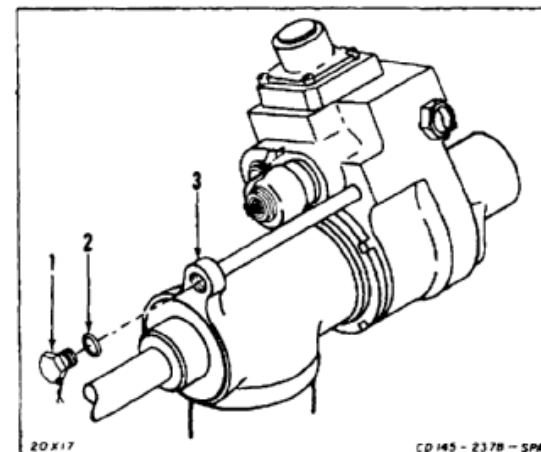
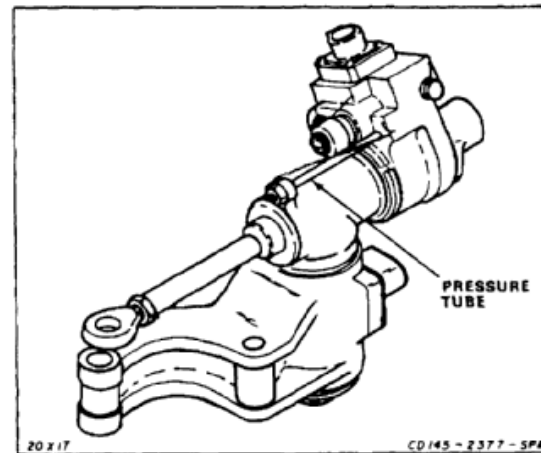

2. Remove tube (4).
3. Remove packing (5) and retainer (6) from housing (2).
4. Remove retainer (7) and packing (8) from housing (9).
5. Check tube (4) for dents and scratches. Dents shall not be deeper than **0.050 inch**. Scratches shall not be deeper than **0.005 inch**.

FOLLOW-ON MAINTENANCE:

None

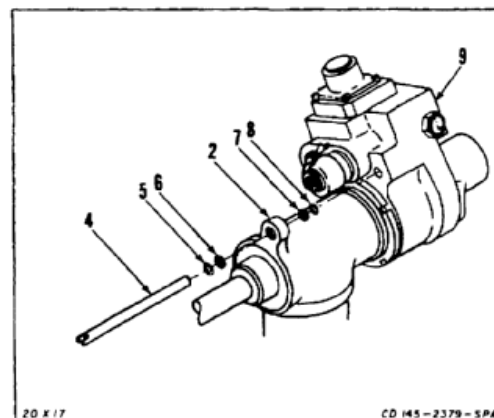

END OF TASK

INITIAL SETUP

Applicable Configurations:

All

Tools:

Aircraft Mechanic's Tool Kit, NSN 1520-00-323-4692

Materials:

Lockwire (E231)
 Hydraulic Fluid (E199)
 Gloves (E186)

Parts:

Preformed Packings
 Retainers

Personnel Required:

Medium Helicopter Repairer
 Inspector

References:

TM 55-1520-240-23P

1. Install retainer (1) and packing (2) in housing (3).
2. Install packing (4) and retainer (5) in housing (6).

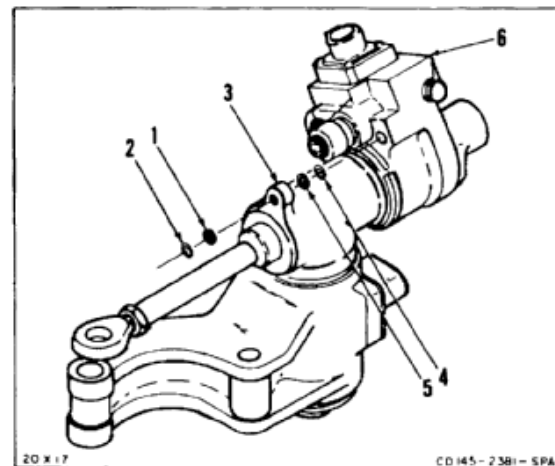
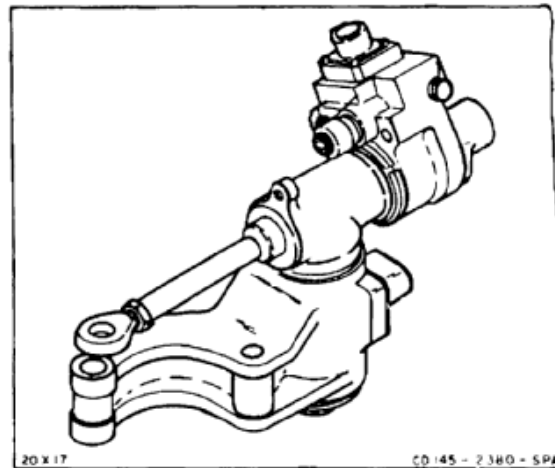

7-302 INSTALL POWER STEERING ASSEMBLY PRESSURE TUBE (AVIM) (Continued)**7-302**

3. Lubricate outside of tube (7). Use hydraulic fluid (E199). Use gloves (E186).
4. Install tube (7) through housing (3) into housing (6).
5. Install packing (8) and plug and bleeder (9) in housing (3).
6. Lockwire plug and bleeder (9). Use lockwire (E231).

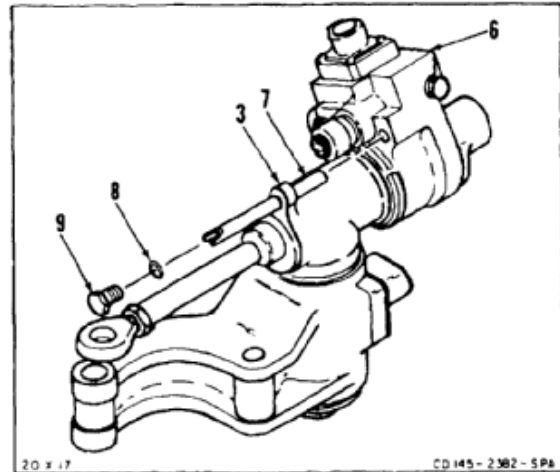
**INSPECT****FOLLOW-ON MAINTENANCE:**

None

END OF TASK

INITIAL SETUP

Applicable Configurations:

All

Tools:

Aircraft Mechanic's Tool Kit, NSN 5180-00-323-4692

Materials:Cloths (E135)
Gloves (E186)**Personnel Required:**

Medium Helicopter Repairer

Equipment Condition:Battery Disconnected (Task 1-39)
Electrical Power Off
Hydraulic Power Off
Utility Hydraulic System Depressurized (Task 7-135.1)
Aft Right Landing Gear Access Panel Open (Task 2-2)**General Safety Instructions:****WARNING**

Hydraulic fluid (E199) is toxic. It can irritate skin and cause burns. Avoid inhaling. Use only with adequate ventilation. Avoid contact with skin, eyes, or clothing. In case of contact, immediately flush skin or eyes with water for at least **15 minutes**. Get medical attention for eyes.

WARNING

Hydraulic fluid ejected under pressure can cause injury to personnel. Hydraulic fluid sprayed into the air is a fire hazard.

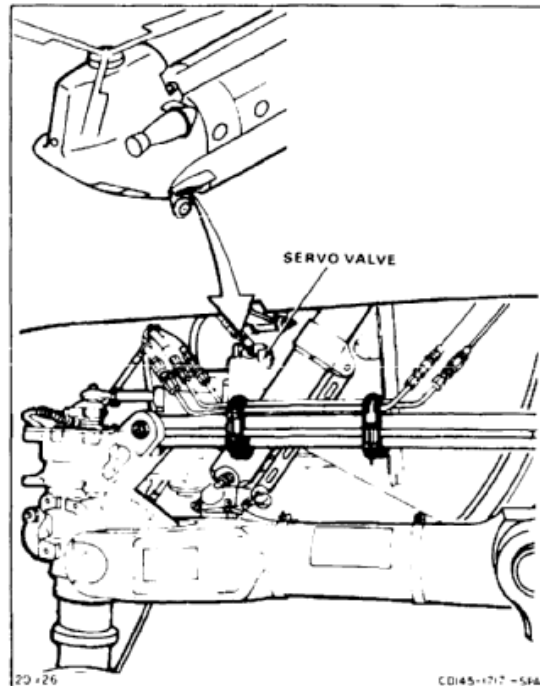

7-303 REMOVE POWER STEERING SERVO VALVE (Continued)

7-303

1. Disconnect electrical plug (1) from servo valve (2).
2. Remove lockwire from four screws (3).

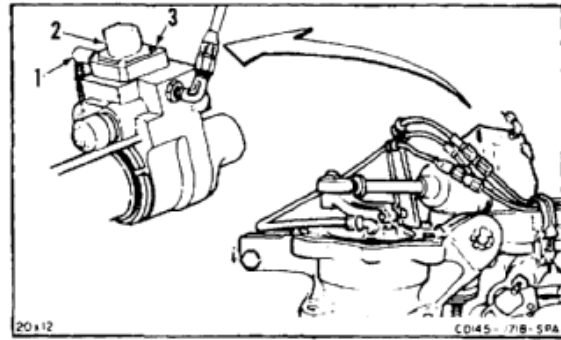

3. Remove four screws (3) and washers (4).
4. Remove valve (2) and four packings (5). Use cloth (E135) for spilled fluid. Use gloves (E186).
5. Plug open ports of valve (2) and actuator (6) to prevent contamination.

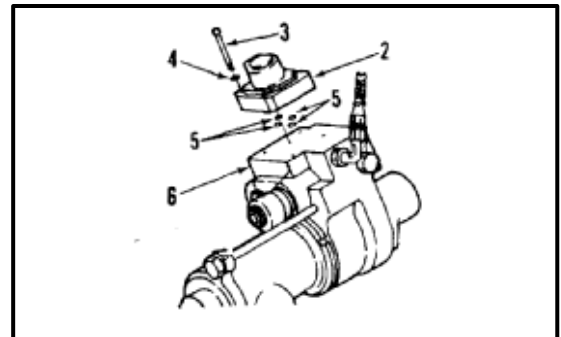
**FOLLOW-ON MAINTENANCE:**

None

END OF TASK

INITIAL SETUP

Applicable Configurations:

All

Tools:

Aircraft Mechanic's Tool Kit, NSN 5180-00-323-4692

Materials:

Lockwire (E231)

Parts:

Preformed Packings

Personnel Required:Medium Helicopter Repairer
Inspector**References:**

TM 55-1520-240-23P

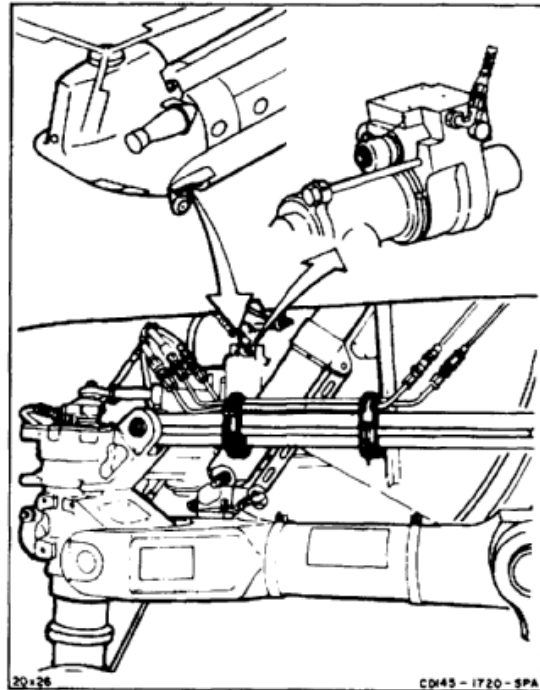

1. Install four packings (1) in actuator (2).
2. Position servo valve (3) on actuator (2) with connector (4) pointing inboard.
3. Install four washers (5) and screws (6).

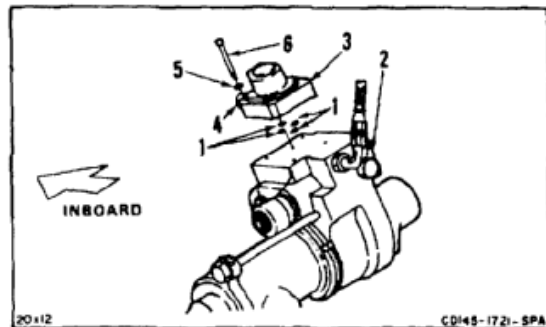

4. Connect electrical plug (7) to servo valve (3).
5. Lockwire four screws (6). Use lockwire (E231).

INSPECT**FOLLOW-ON MAINTENANCE:**

Bleed power steering system (Task 7-332).
 Perform power steering operational check (TM 55-1520-240-T).
 Close aft right landing gear access panel (Task 2-2).

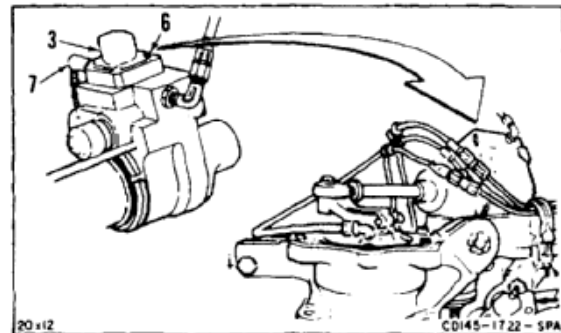

END OF TASK

7-1106

INITIAL SETUP

Applicable Configurations:

All

Tools:

Aircraft Mechanic's Tool Kit, NSN 51 80-00-323-4692

Materials:

None

Personnel Required:

Medium Helicopter Repairer (2)

Equipment Condition:

- Battery Disconnected (Task 1-39)
- Electrical Power Off
- Hydraulic Power Off
- Aft Right Landing Gear Access Panel Open (Task 2-2)

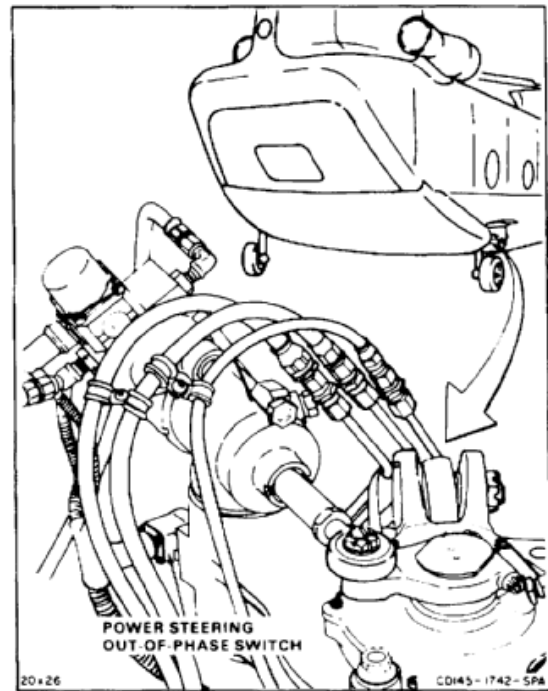

1. Disconnect cable plug (1) from out-of-phase switch (2).
2. Remove lockwire from four mounting screws (3).

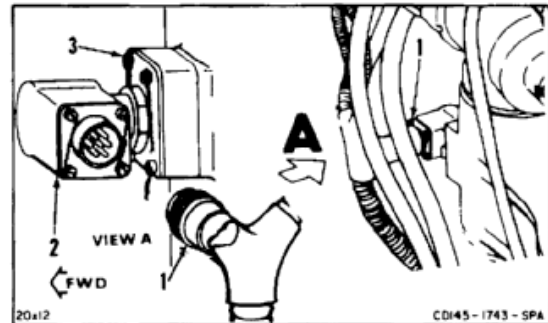

3. Remove four screws (3) and washers (4).
4. Remove switch (2) from actuator (5).
5. Remove packing (6), spacer (7) and packing (8).
6. Remove lockwire from nut (9) and lockring (10).

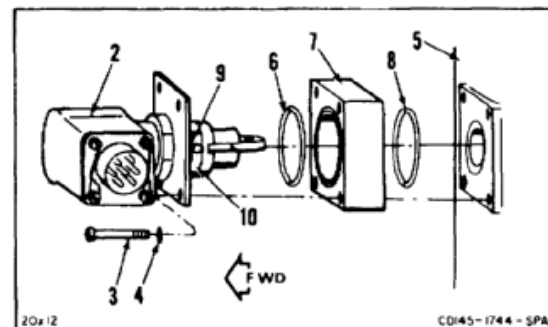

7. Remove lockring (10) from guide (11). Remove guide from switch (2).
8. Remove nut (9) and washer (12).
9. Remove plate (13) and key washer (14).

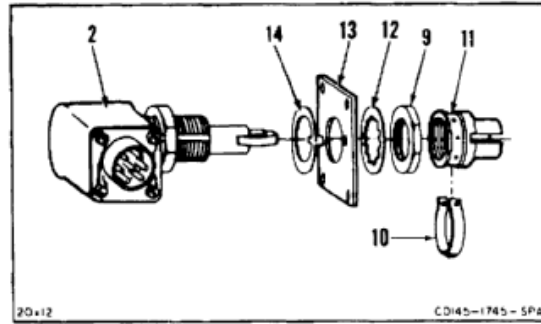
**FOLLOW-ON MAINTENANCE:**

None

END OF TASK

7-1108

INITIAL SETUP

Applicable Configurations:

All

Tools:

Aircraft Mechanic's Tool Kit, NSN 51 80-00-323-4692

Materials:

Lockwire (E231)
Cloths (E120)

Parts:

Preformed Packing

Personnel Required:

Medium Helicopter Repairer (2)
Inspector

References:

TM 55-1520-240-23P

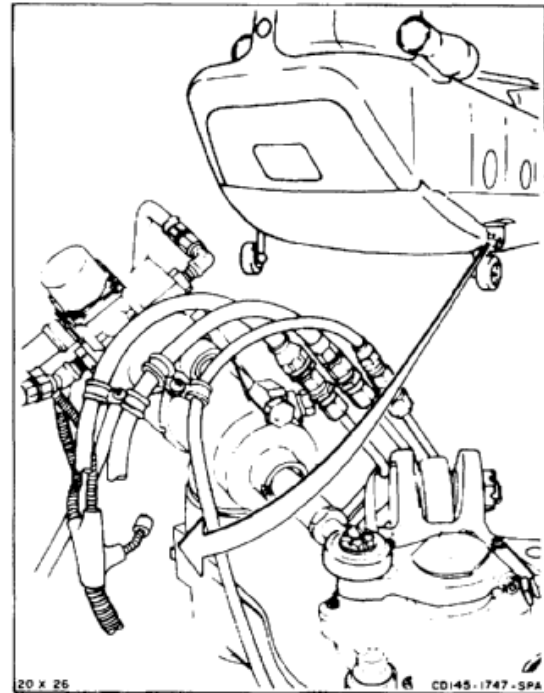

1. Make sure nut (1) is positioned on out-of-phase switch (2) with **two threads** showing between nut and switch as shown.

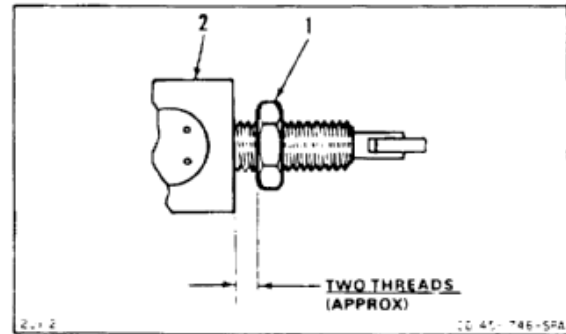

2. Install key washer (3) on switch (2). Align key with slot in switch shaft (4) and tang pointing to plate (5).
3. Install plate (5) on switch shaft (4) with tang of washer (3) in plate hole.
4. Install washer (6) and nut (7).

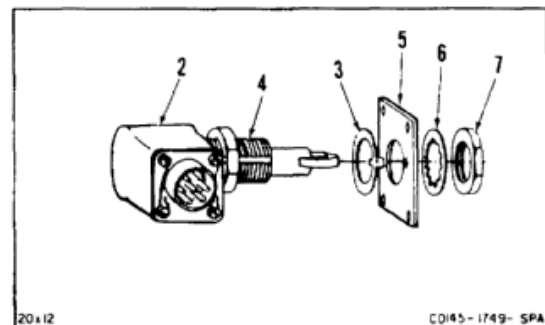

5. Install guide (8) on shaft (4) until guide bottoms out. Turn guide back to align guide clevis with shaft slot as shown.
6. Install locking (9) in groove (10) of guide (6). Align pin (11) with guide clevis (12) and shaft slot (13). Make sure pin seats in groove hole (14).
7. Lockwire locking (9) to nut (7). Use lockwire (E231) through both holes of locking.

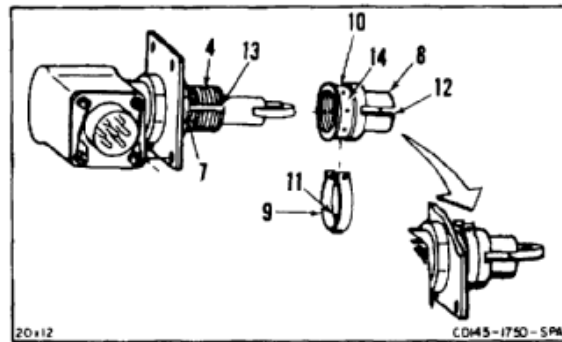

8. Install two packings (15), spacer (16), and switch (2). Position switch against actuator (17) and align holes as shown.

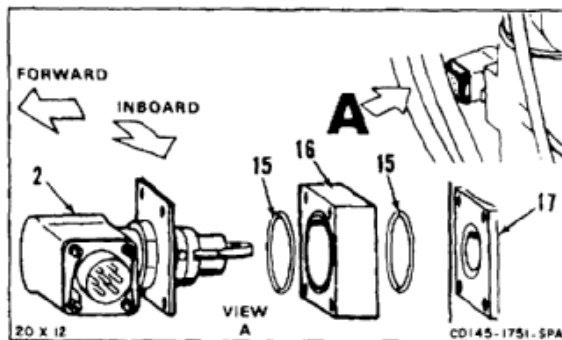

9. Install four washers (18) and screws (19).
10. Lockwire screws (19) to nut (1). Use lockwire (E231).

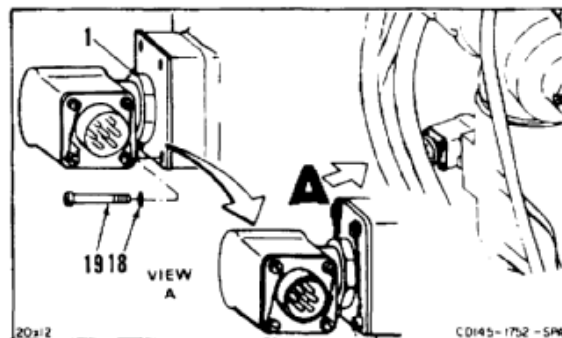

11. Connect cable plug (20) to switch (2).

INSPECT

FOLLOW-ON MAINTENANCE:

Perform operational check of out-of-phase switch (TM 55-1520-240-T).
Close aft right landing gear access panel (Task 2-2).

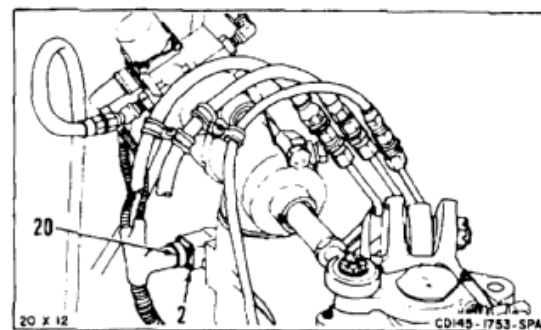

END OF TASK

7-307 ADJUST POWER STEERING OUT-OF-PHASE SWITCH

7-307

INITIAL SETUP**Applicable Configurations:**

All

Tools:

Aircraft Mechanic's Tool Kit, NSN 5180-00-323-4692

Materials:

Lockwire (E231)

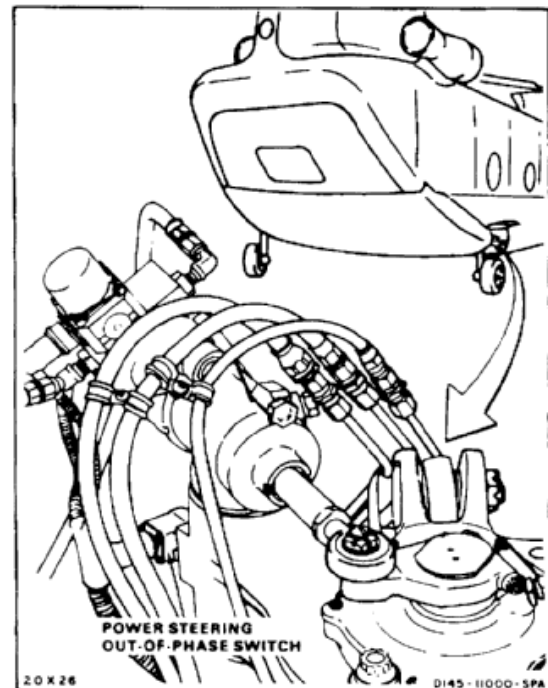
Personnel Required:Medium Helicopter Repairer
Inspector**References:**TM 55-1520-240-T
Task 1-39**Equipment Condition:**Battery Disconnected (Task 1-39)
Electrical Power Off
Hydraulic Power Off
Aft Right Landing Gear Access Panel Open (Task 2-2)**REMOVE SWITCH**

1. Disconnect electrical connector (1) from out-of-phase switch (2).
2. Remove lockwire from four screws (3). Remove screws and washers (4).

NOTE

Spacer is not fastened to actuator. If not held, it can come off with switch.

3. Hold spacer (5) against actuator (6). Remove switch (2) and plate (7) as a unit.

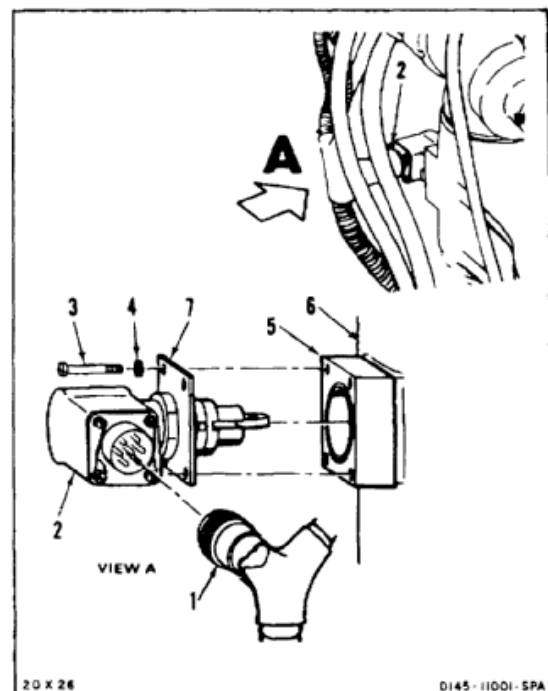

ADJUST SWITCH

4. Remove lockwire from jam nuts (8 and 9).
5. If switch (2) activates early, turn each nut (8 and 9) an equal amount away from roller (10), no more than one flat.
6. If switch (2) activates late, turn each nut (8 and 9) an equal amount toward roller (10), no more than one flat.

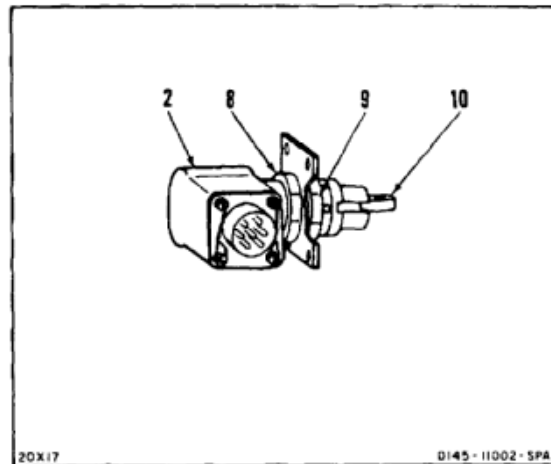

7. Install switch (2) and plate (7) as a unit on spacer (5). Install four screws (3) and washers (4).
8. Connect electrical connector (1).
9. Perform an operational test of switch (2) (TM 55-1520-240-T). If test is good, go to step 15. If test is not good, go to step 10.

NOTE

Lockwire removal is not needed for repeated steps.

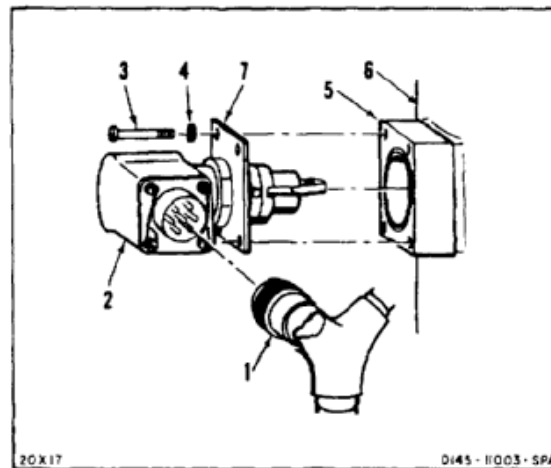

10. Disconnect battery (Task 1-39).
11. Repeat steps 1 thru 9. Install switch.
12. Repeat steps 1 and 3.
13. Lockwire jam nut (9) to locking (11).
14. Install switch (2) and plate (7) as a unit spacer (5). Install four screws (3) and washers (4).

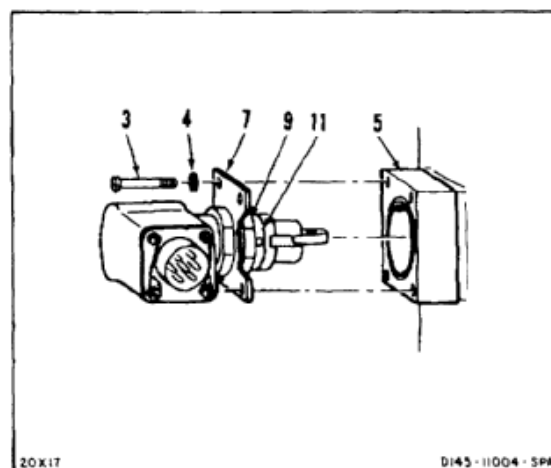

15. Lockwire screws (3) to nut (8). Use lockwire (E230).
16. Connect electrical connector (1) to switch (2).

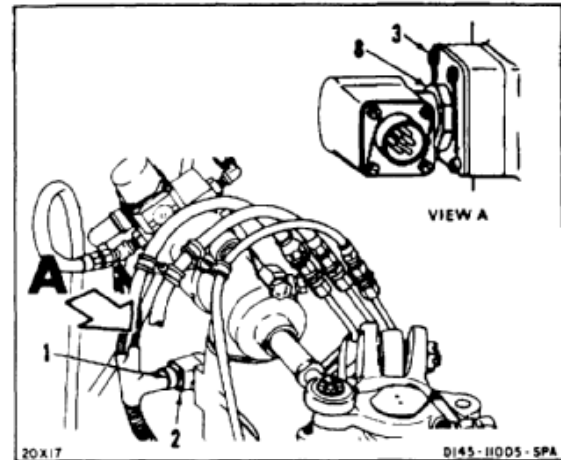
**INSPECT****FOLLOW-ON MAINTENANCE:**

Close aft landing gear access panel (Task 2-2).

END OF TASK

INITIAL SETUP

Applicable Configurations:

All

Tools:

Aircraft Mechanic's Tool Kit, NSN 5180-00-323-4692
Container, 2 Quart

Materials:

Cloths (E135)
Tags (E264)
Gloves (E186)

Personnel Required:

Medium Helicopter Repairer

Equipment Condition:

Battery Disconnected (Task 1-39)
Electrical Power Off
Hydraulic Power Off
Utility Hydraulic System Depressurized (Task 7-135.1)

General Safety Instructions:**WARNING**

Hydraulic fluid (E199) is toxic. It can irritate skin and cause burns. Avoid inhaling. Use only with adequate ventilation. Avoid contact with skin, eyes, or clothing. In case of contact, immediately flush skin or eyes with water for at least **15 minutes**. Get medical attention for eyes.

WARNING

Hydraulic fluid ejected under pressure can cause injury to personnel. Hydraulic fluid sprayed into the air is a fire hazard.

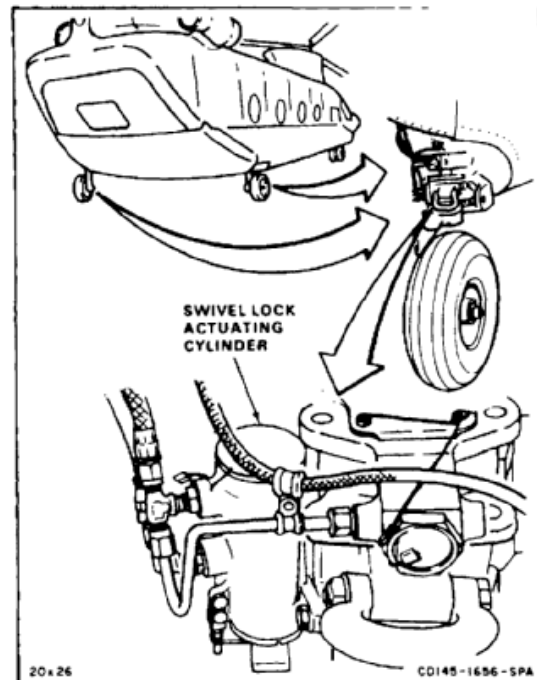

NOTE

This task is same for left or right actuating cylinders. Right is shown here.

1. Tag and disconnect two hoses (1) from cylinder (actuator) (2). Use container and cloths (E135) for spilled fluid. Use gloves (E186).
2. Loosen nut (3), disconnect tube (4) from tee (5).
3. Loosen two nuts (6).

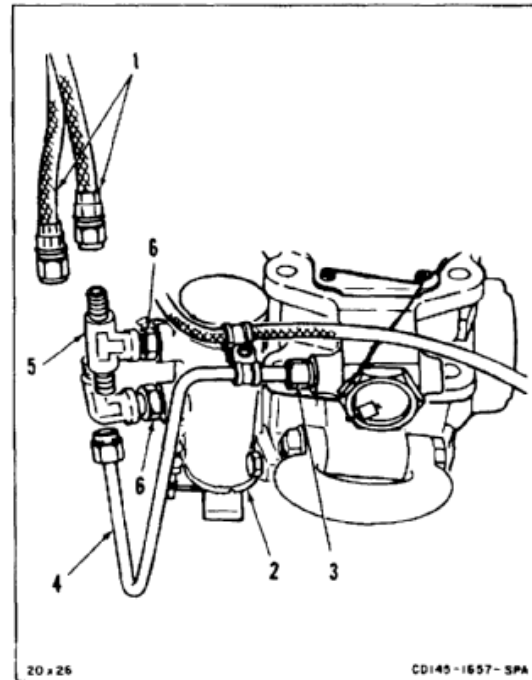

4. Remove elbow (7), washer (8), and packing (9).
5. Remove tee (5), washer (10), and packing (11).
6. Remove lockwire from four bolts (12).

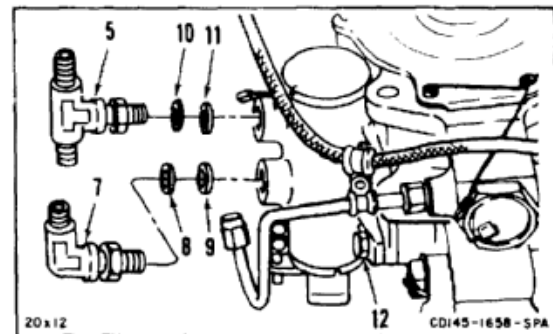

7. Remove four bolts (12) and washers (13). Remove actuator (2).

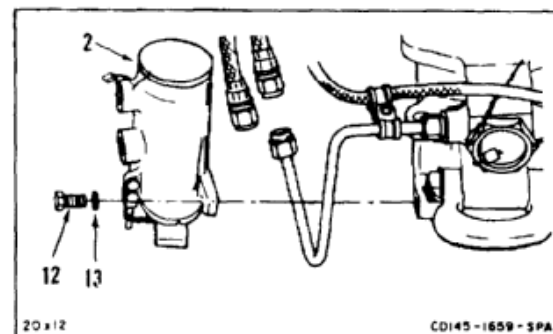

FOLLOW-ON MAINTENANCE:

None

END OF TASK

INITIAL SETUP

Applicable Configurations:

All

Tools:

Hydraulic Repairer's Tool Kit, NSN 5180-00-323-4891
 Soft Jawed Vise
 Spanner Wrench

Materials:

None

Personnel Required:

Aircraft Pneudraulics Repairer

Equipment Conditions:

Off Helicopter Task

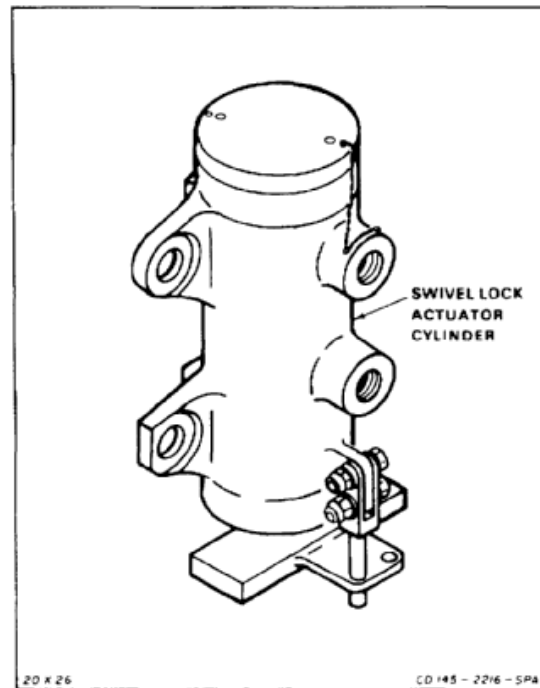

1. Clamp cylinder (1) with plug (2) up in vise (3).
2. Remove lockwire, plug (2), and packing (4) from cylinder (1). Use spanner wrench.
3. Loosen nut (5) in cylinder (1).
4. Remove cylinder (1) from vise (3).

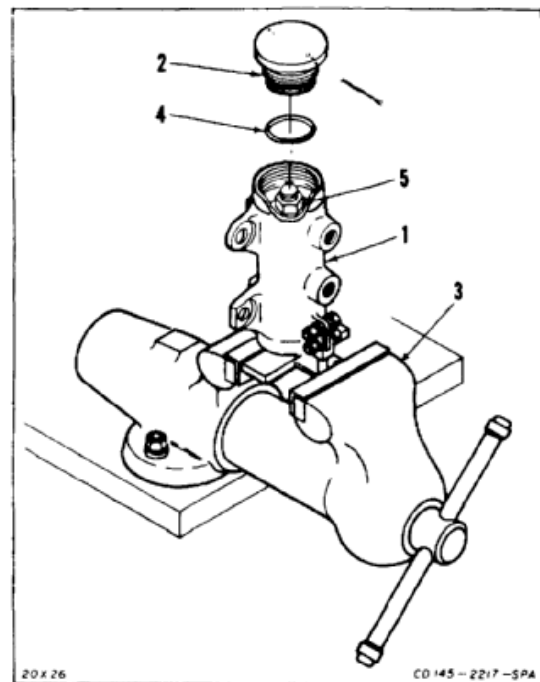

WARNING

Actuator cylinder is spring-loaded.
Remove nut carefully to prevent injury
to personnel.

5. Remove nut (5), washer (6), and piston (7) from cylinder (1).
6. Remove two retainers (8) and packings (9 and 10) from piston (7).
7. Remove spring (11), spacer (12), and rod (13) from cylinder (1).

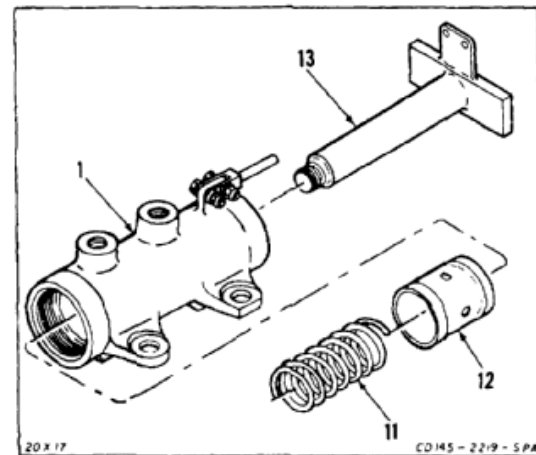
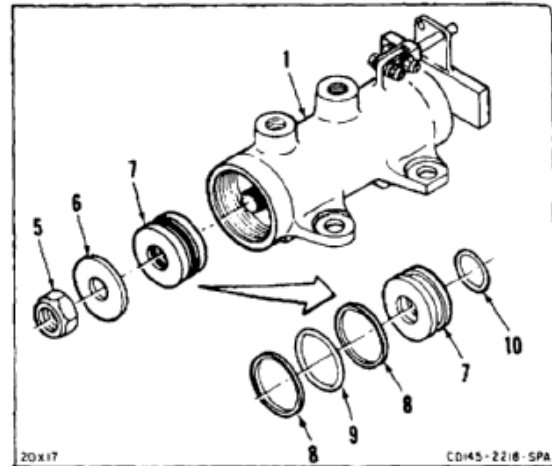

8. Remove retaining ring (14), wiper ring (15), two retainers (16), and packing (17) from cylinder (1).
9. Remove two nuts (18), two washers (19), and two bolts (20). Remove rod end clevis (21) from cylinder (1).

FOLLOW-ON MAINTENANCE:

None

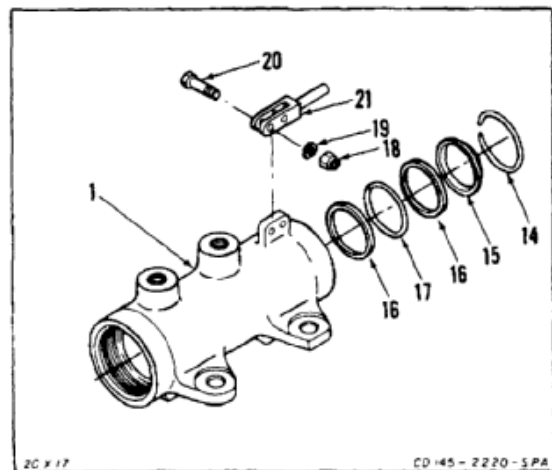

END OF TASK

INITIAL SETUP

Applicable Configurations:

All

Tools:

Hydraulic Repairer's Tool Kit, NSN 5180-00-323-4891
 Hand Oiler, 16 Ounce
 Container, 2 Quart
 Paint Brush, Size 6

Materials:

Cloths (E135)
 Dry Cleaning Solvent (E162)
 Hydraulic Fluid (E199)
 Gloves (E186)

Personnel Required:

Aircraft Pneudraulics Repairer

Equipment Condition:

Off Helicopter Task
 Swivel Lock Actuator Disassembled (Task 7-309)

1. Remove dirt, oil, and grease from washer (1), spring (2), sleeve spacer (3), and rod end clevis (4). Use dry cleaning solvent (E162) and brush. Use goggles for eyes.

General Safety Instructions:**WARNING**

Dry cleaning solvent (E162) is flammable and toxic. It can irritate skin and cause burns. Use only in well-ventilated area, away from heat and open flame. In case of contact, immediately flush skin or eyes with water for at least **15 minutes**. Get medical attention for eyes.

WARNING

Hydraulic fluid (E199) is toxic. It can irritate skin and cause burns. Avoid inhaling. Use only with adequate ventilation. Avoid contact with skin, eyes, or clothing. In case of contact, immediately flush skin or eyes with water for at least **15 minutes**. Get medical attention for eyes.

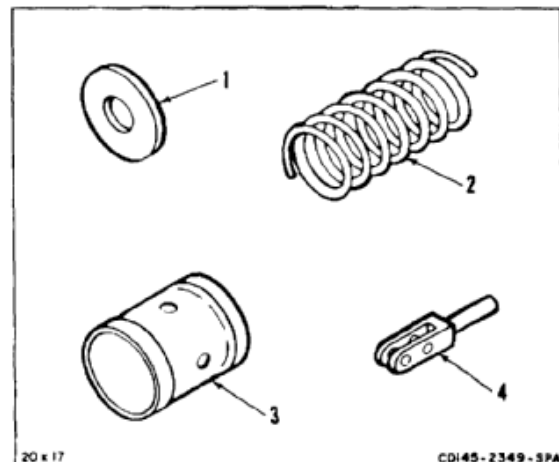

2. Clean plug (5), nut (6) piston (7), and piston rod (8). Use dry cleaning solvent (E162) and brush. Use goggles for eyes. Use gloves (E186).

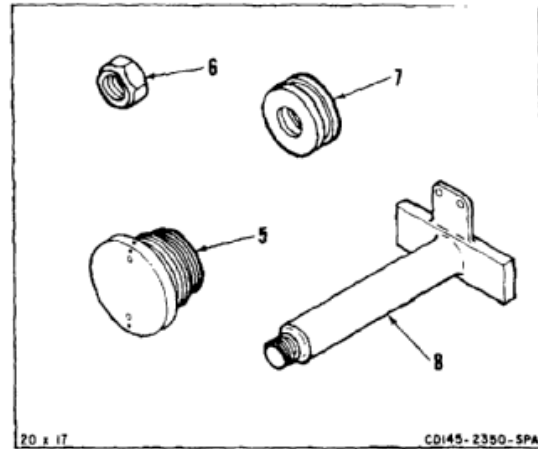

3. Spray inside surfaces of cylinder (9) with dry cleaning solvent (E162). Use hand oiler (10). Use goggles for eyes. Use gloves (E186).
4. Flush inside surfaces and passages of cylinder (9). Use hydraulic fluid (E199) to remove all dirt or foreign matter. Use gloves (E186).
5. Spray inside surfaces of cylinder (9) with dry cleaning solvent (E162) to remove hydraulic fluid. Use goggles for eyes. Use gloves (E186).
6. Drain cylinder (9). Use container dry cylinder with cloths (E135).

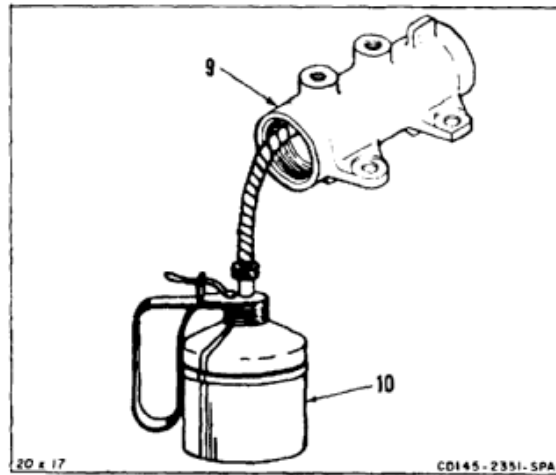

FOLLOW-ON MAINTENANCE:

Inspect swivel lock actuator (Task 7-311).

END OF TASK

INITIAL SETUP

Applicable Configurations:

All

Tools:

Technical Inspection Tool Kit, NSN 5180-00-323-5114
 Spring Compression Tester
 Outside Micrometer Caliper, 1 to 2 Inches
 Telescoping Gage Set
 Torque Wrench, 100 to 750 Inch-Pounds

Materials:

None

Personnel Required:

Inspector

References:

Task 7-1.1

Equipment Condition:

Off Helicopter Task
 Actuator Cylinder Disassembled (Task 7-309)

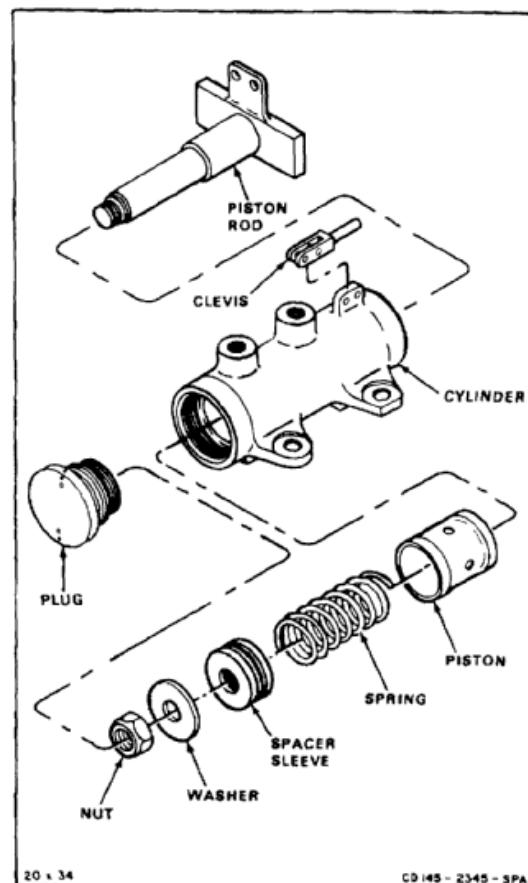
**NOTE**

General inspection criteria (Task 7-1.1) for obvious damage applies unless otherwise stated.

Inspection steps cover parts that are subject to wear.

1. Measure free length of spring (1). Free length of spring shall be **3.0 inches**.
2. Install torque wrench (2) on spring compression tester (3).
3. Compress spring to **2.25 inches**. Use spring compression tester (3). Pressure to compress spring shall be **185 to 195 pounds**.

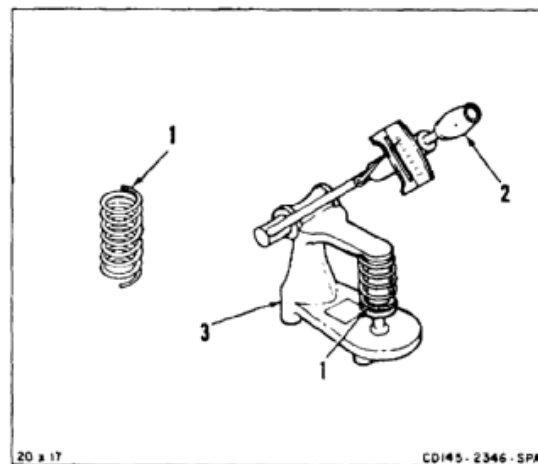

7-311 INSPECT SWIVEL LOCK ACTUATOR CYLINDER (AVIM) (Continued)

7-311

4. Measure large diameter (4) of piston rod (5). Diameter shall not be less than **1.121 inches**. Measure piston rod locking plate (5). Length shall be **3.217 ±.005**.

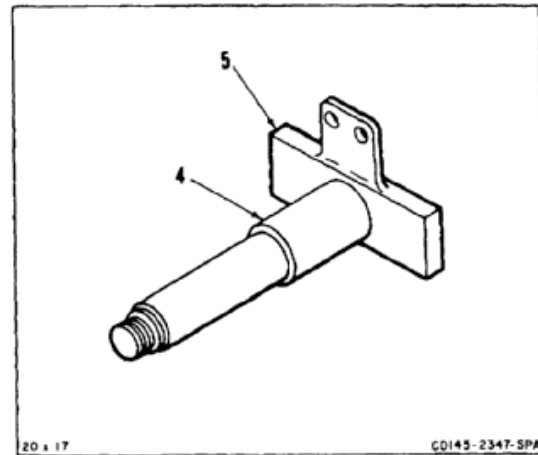

5. Measure inside diameter of cylinder (6). Diameter shall not be less than **1.618 inches**.
6. Measure diameter of bore (7) at end of cylinder (6). Bore shall not be more than **1.126 inches**.

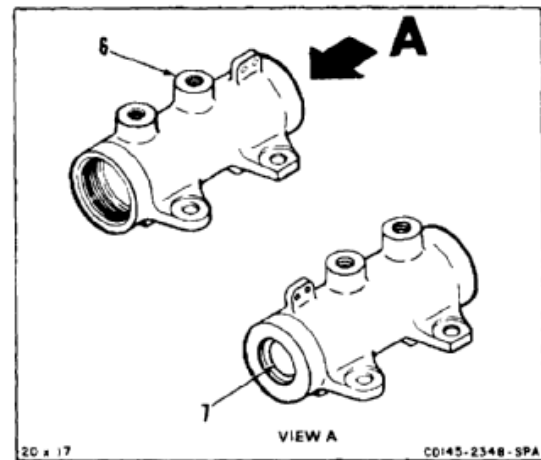
**FOLLOW-ON MAINTENANCE:**

None

END OF TASK

7-1121

INITIAL SETUP

Applicable Configurations:

All

Tools:

Hydraulic Repairer's Tool Kit, NSN 5180-00-323-4891
 Torque Wrench, 150 to 750 Inch-Pounds
 Soft Jawed Vise
 Spanner Wrench

Materials:

Lockwire (E231)

Parts:

Packings
 Retainers

Personnel Required:

Aircraft Pneudraulics Repairer
 Inspector

References:

TM 55-1520-240-23P

1. Install rod end clevis (1), two bolts (2), washers (3), and nuts (4) on cylinder (5).
2. Install two retainers (6), packing (7), wiper ring (8), and retaining ring (9) in cylinder (5).

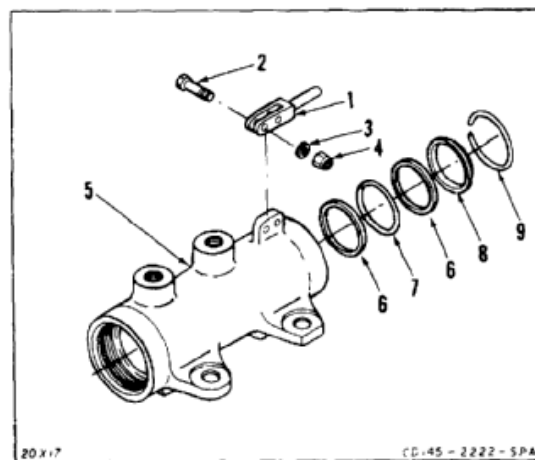

3. Install piston rod (10) in cylinder (5) with rod end clevis (1) in one of holes in base of piston rod (10).
4. Install spacer (11) and spring (12) in cylinder (5).

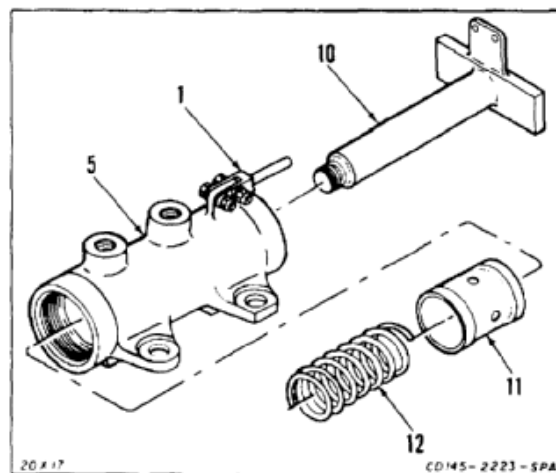

7-312 ASSEMBLE SWIVEL LOCK ACTUATOR CYLINDER (AVIM) (Continued)

7-312

5. Install packing (13) in piston (14).
6. Install two retainers (15) and packing (16) on piston (14).
7. Install piston (14) and washer (17) in actuating cylinder (5).

WARNING

Actuator cylinder shall become spring-loaded when nut is installed. Install nut carefully to prevent injury to personnel.

8. Press down on washer (17) and install nut (18) on piston rod (10).
9. Clamp cylinder (5) in vise (19).
10. Torque nut (18) to **650 inch-pounds**.
11. Install packing (20) and plug (21) on cylinder (5). Use spanner wrench.
12. Lockwire plug (21) to cylinder (5). Use lockwire (E231).

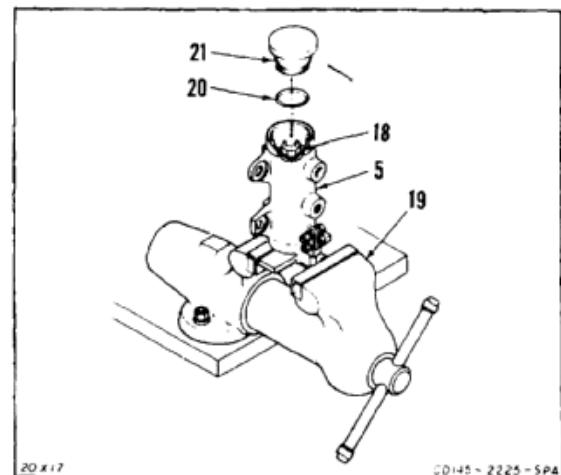
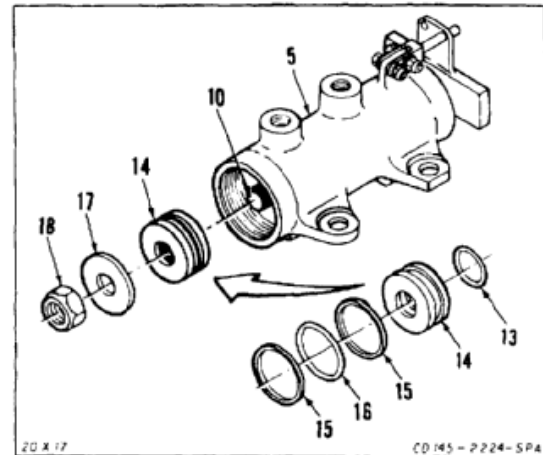
**INSPECT****FOLLOW-ON MAINTENANCE:**

Test swivel lock actuator (Task 7-313).

END OF TASK

7-1123

INITIAL SETUP

Applicable Configurations:

All

Tools:

Hydraulic Repairer's Tool Kit, NSN 5180-00-323-4891
 Hydraulic Test Stand, 0 to 4500 psi
 Control Valve, Three Way, Two Position
 Flexible Hose, 1/4 Inch, 0 to 4500 psi (2)
 Stop Watch

Materials:

None

Personnel Required:

Aircraft Pneudraulics Repairer
 Inspector

Equipment Condition:

Off Helicopter Task
 Swivel Lock Actuator Installed in Crash Proof Box
 Hydraulic Test Setup

General Safety Instructions:**WARNING**

Swivel lock actuator must be installed in crash proof box before performing test. Otherwise, injury to personnel can occur.

WARNING

Hydraulic fluid (E199) is toxic. It can irritate skin and cause burns. Avoid inhaling. Use only with adequate ventilation. Avoid contact with skin, eyes, or clothing. In case of contact, immediately flush skin or eyes with water for at least **15 minutes**. Get medical attention for eyes.

WARNING

Hydraulic fluid ejected under pressure can cause injury to personnel. Hydraulic fluid sprayed into the air is a fire hazard.

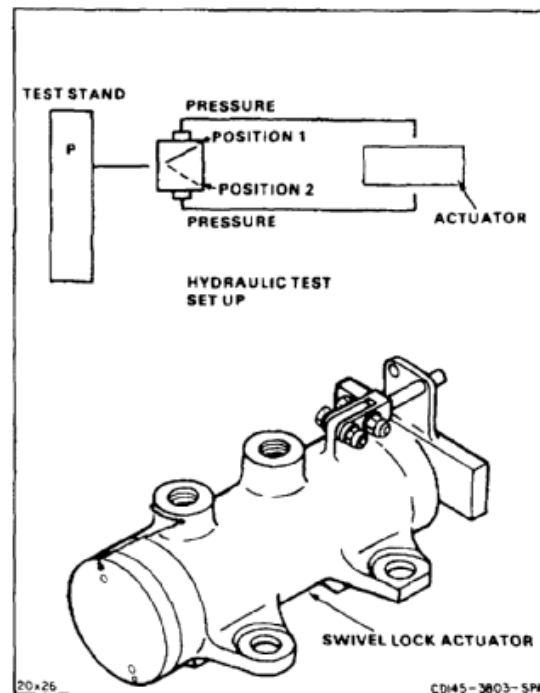

1. Connect test stand pressure hose (1) to port (2) of swivel lock actuator (3).
2. Check that port (4) is open.
3. Apply **4500 psi** pressure to port (2). Maintain pressure for **2 minutes**.
4. Check port (4) for leaks. There shall be no leaks.
5. Reduce pressure at port (2) to **0 psi**.
6. Disconnect pressure hose (1) from port (2).

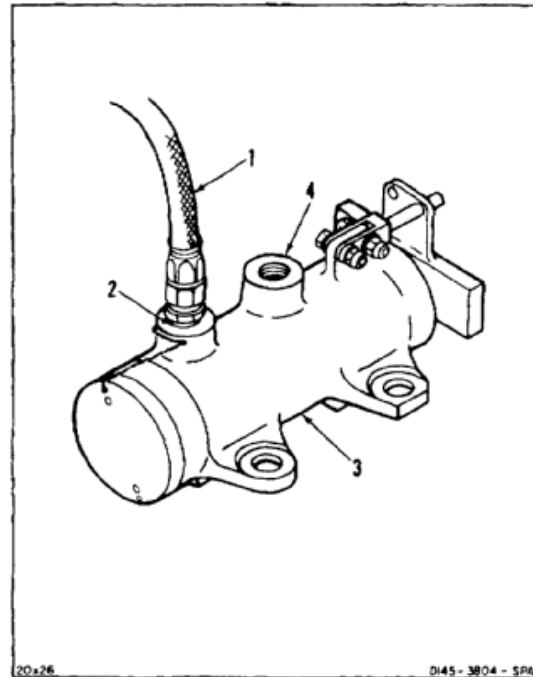

7. Connect pressure hose (1) to port (4) of swivel lock actuator (3).
8. Apply **4500 psi** at pressure to port (4). Maintain pressure for **2 minutes**.
9. Check port (2) for leaks. There shall be no leaks.
10. Reduce pressure at port (4) to **0 psi**.
11. Disconnect pressure hose (1) from port (4).

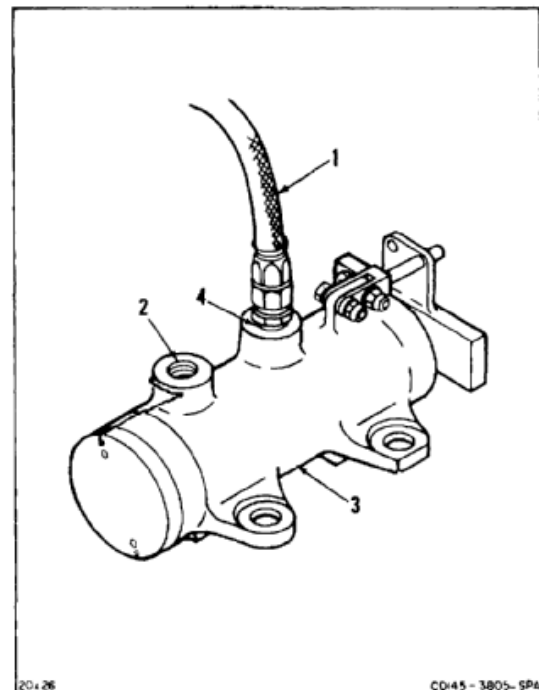

12. Connect pressure hose (1) to valve (5).
13. Connect pressure hose (6) to port (2) of actuator (3).
14. Connect pressure hose (7) to port (4) of actuator (3).
15. Apply **3000 psi** pressure to control valve (5).

NOTE

Swivel lock actuator is cycled by operating handle on control valve from position 1 to position 2 to position 1.

16. Cycle actuator (3) **25 times**.
17. Check actuator (3) for leaks. There shall be no leaks except at piston rod (8). Leaks at piston rod shall be no more than **1 drop in 25 cycles**.

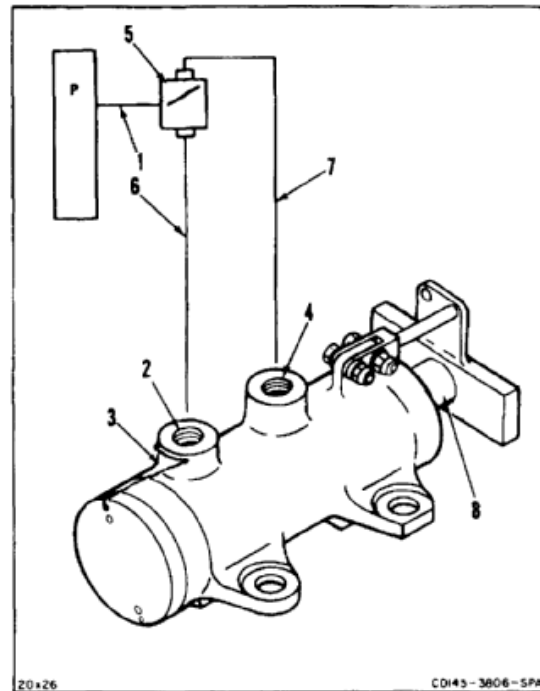

18. Reduce pressure to control valve (5) to **0 psi**.
19. Disconnect hoses (6 and 7) from actuator (3).

INSPECT**FOLLOW-ON MAINTENANCE:**

None

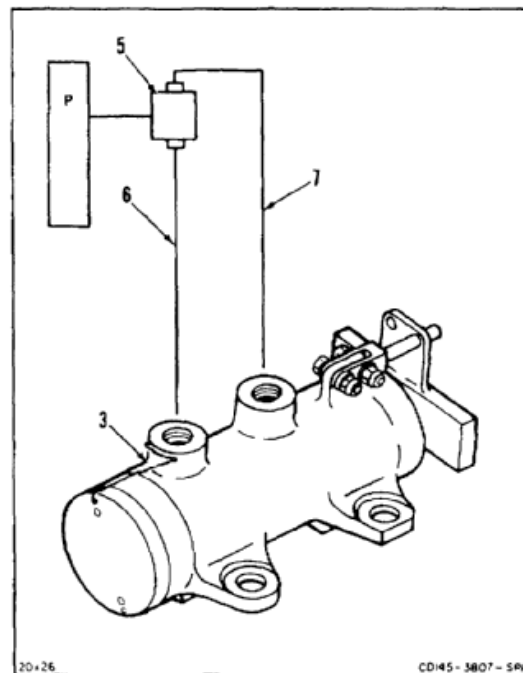

END OF TASK

7-1126

7-314 INSTALL SWIVEL LOCK ACTUATING CYLINDER (ACTUATOR)

7-314

INITIAL SETUP**Applicable Configurations:**

All

Tools:

Aircraft Mechanic's Tool Kit, NSN 51 80-00-323-4692

Materials:

Lockwire (E231)

Parts:Preformed Packing
Nonmetallic Washers**Personnel Required:**Medium Helicopter Repairer (2)
Inspector**References:**

TM 55-1520-240-23P

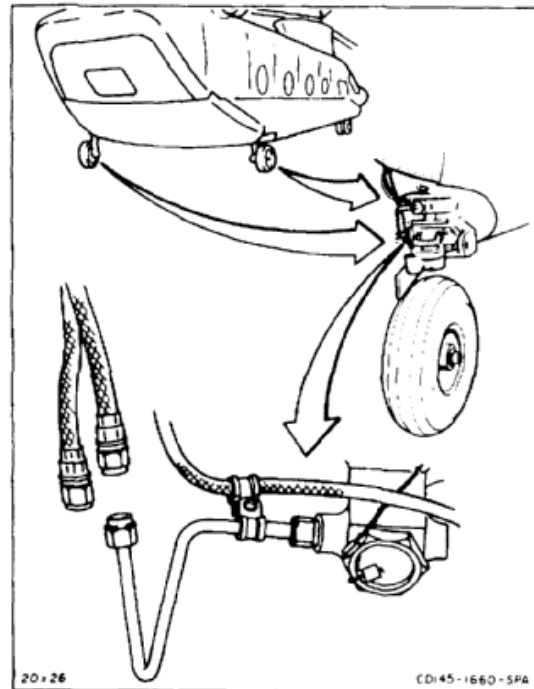
**NOTE**

This task is same for left or right actuating cylinders. Right is shown here.

1. Position actuating cylinder (actuator) (1) as shown. Install four washers (2) and bolts (3).
2. Lockwire four bolts (3). Use lockwire (E231).

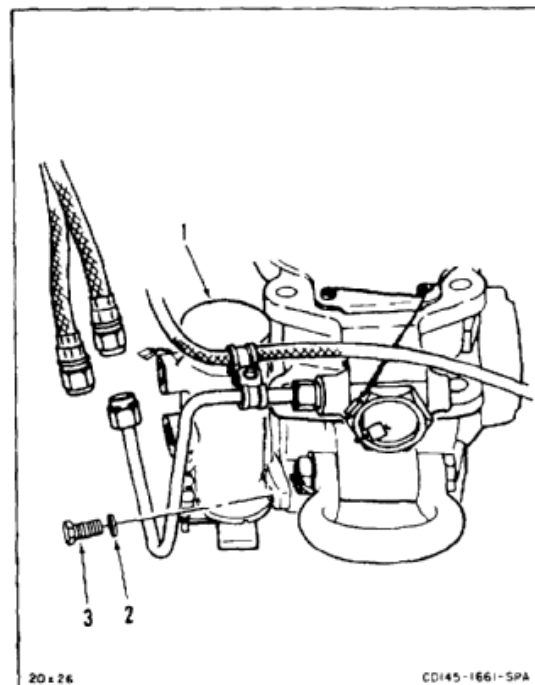

3. Install packing (4), washer (5), and tee (6) in pressure port (7).
4. Install packing (8), washer (9), and elbow (10) in return port (11).

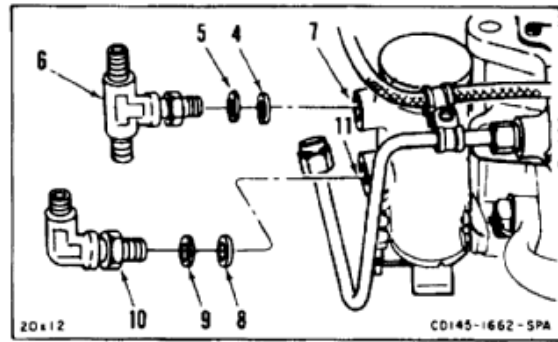

5. Connect tube (12) to tee (6).
6. Connect pressure hose (13) to tee (6). Remove tag.
7. Connect return hose (14) to elbow (10). Remove tag.

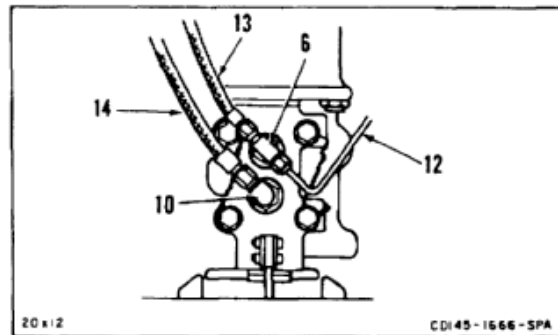

8. Tighten two nuts (15).
9. Tighten nut (16).

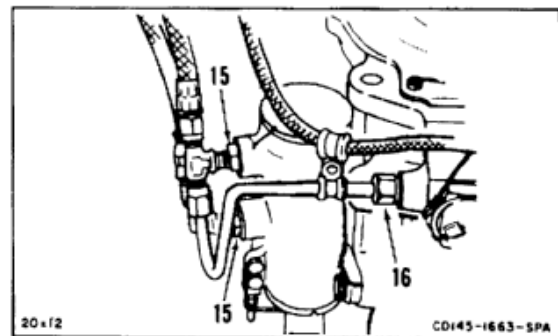

INSPECT

FOLLOW-ON MAINTENANCE:

Bleed swivel lock actuating cylinder (Task 7-331).
 Perform operational check (TM 55-1520-240-T).

END OF TASK

7-1128

INITIAL SETUP

Applicable Configurations:

All

Tools:

- Hydraulic Repairer's Tool Kit, NSN 5180-00-323-4891
- Hoses
- Test Stand
- Container, 2 Quart

Materials:

Cloths (E135)

Personnel Required:

- Aircraft Pneudraulics Repairer (2)
- Inspector

Equipment Condition:

- Battery Disconnected (Task 1-39)
- Electrical Power Off
- Hydraulic Power Off
- Utility Hydraulic System Depressurized (Task 7-135.1)
- Pressure Control Module Removed (Task 7-152)
- Cargo Ramp Open and Level (TM 55-1520-240-T)
- Right and Left Engine Lower Access Covers Open (Task 4-49)

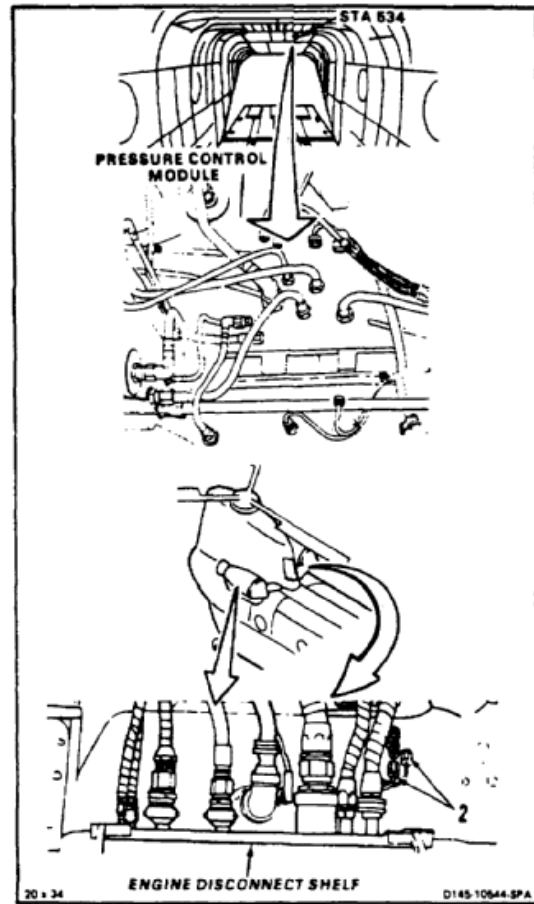

Filter assembly kit ADHT6814-M9716M must be installed in test stand pressure line. Otherwise, system can be contaminated.

NOTE

To operate hydraulic test stand, refer to applicable manual.

1. Working from ramp, connect hose (1) to RH ENG START PRESS tube (2).
2. Connect hose (1) to LH ENG START PRESS tube (3).

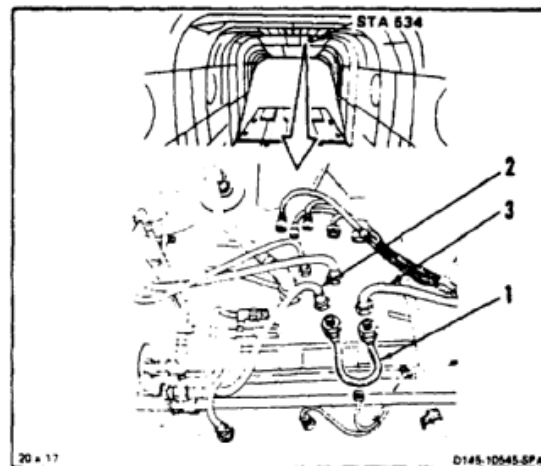

3. Working at right engine, disconnect ENG START PRESS hose (4) from fitting (5) on right engine disconnect shelf (6).
4. Connect return hose (7) from test stand to fitting (5).
5. Working at left engine, disconnect ENG START PRESS hose (8) from fitting (9) on left engine disconnect shelf (10).
6. Connect pressure hose (11) from test stand to fitting (9).

CAUTION

Do not exceed **500 psi**. Otherwise, damage to components can occur.

CAUTION

Keep test stand bypass valve closed. Otherwise, contaminants could re-enter the system.

7. Apply hydraulic power. Set stand to **10 gpm at 500 psi**. Flush system for **15 minutes**. Check for leaks.

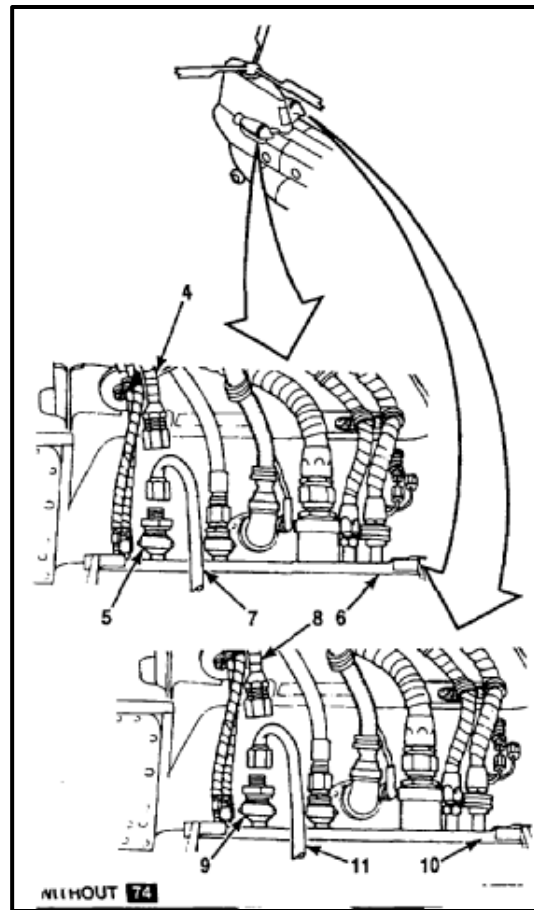

8. Remove hydraulic power.
9. Disconnect hose (11) from fitting (9). Use container and cloths (E135) for spilled fluid.
10. Connect hose (8) to fitting (9).
11. Disconnect hose (7) from fitting (5). Use container and cloths (E135) for spilled fluid.
12. Connect hose (4) to fitting (5).

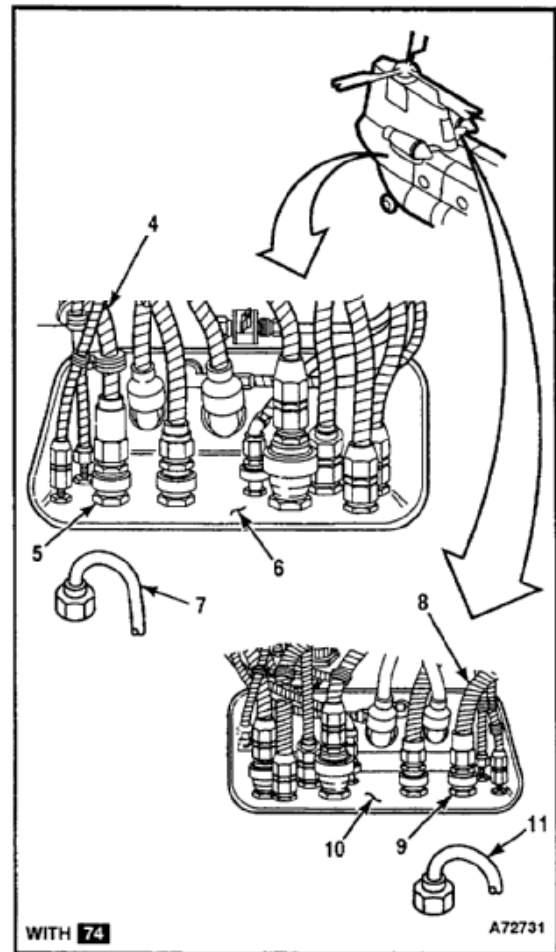

FOLLOW-ON MAINTENANCE:

- Install pressure control module (Task 7-153).
- Close left and right engine lower access covers (Task 4-50).
- Perform operational check of engine start system (TM 55-1520-240-T).

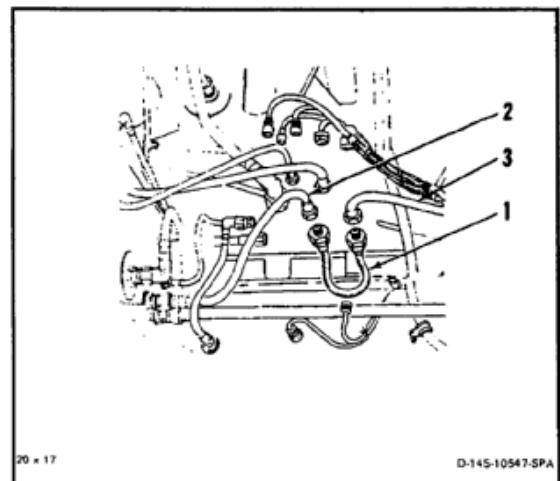

END OF TASK

INITIAL SETUP

Applicable Configurations:

All

Tools:

Hydraulic Repairer's Tool Kit, NSN 5180-00-323-4891
 Hoses
 Test Stand
 Container, 2 Quart

Materials:

Cloths (E135)
 Gloves (E184.1)

Personnel Required:

Aircraft Pneudraulics Repairer (2)
 Inspector

Equipment Condition:

Battery Disconnected (Task 1-39)
 Electrical Power Off
 Hydraulic Power Off
 Utility Hydraulic System Depressurized (Task 7-135.1)
 Cargo Ramp Open and Level (TM 55-1520-240-T)
 Right and Left Engine Lower Access Covers Open
 (Task 4-49)

General Safety Instructions:**WARNING**

Hydraulic fluid (E199) is toxic. It can irritate skin and cause burns. Avoid inhaling. Use only with adequate ventilation. Avoid contact with skin, eyes, or clothing. In case of contact, immediately flush skin or eyes with water for at least **15 minutes**. Get medical attention for eyes.

WARNING

Hydraulic fluid ejected under pressure can cause injury to personnel. Hydraulic fluid sprayed into the air is a fire hazard.

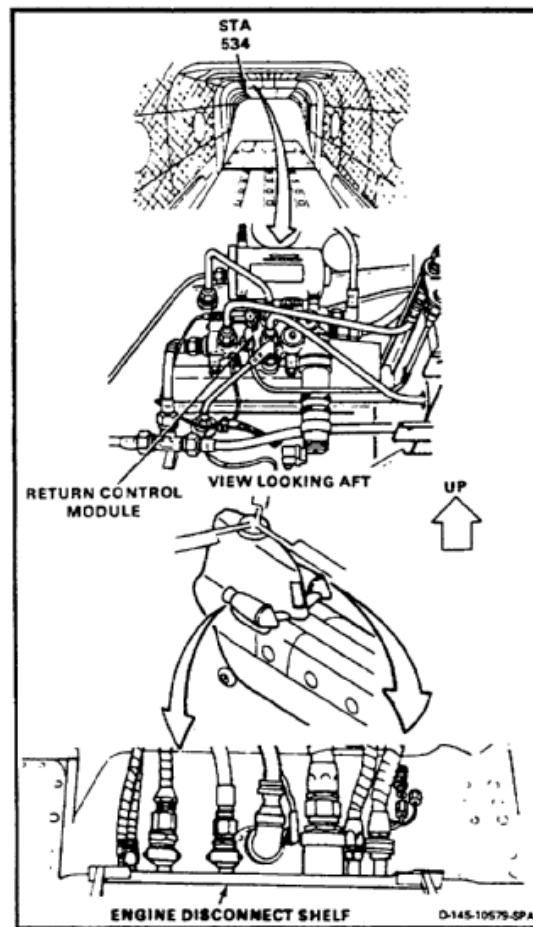

CAUTION

Filter assembly kit ADHT6814-M9716M must be installed in test stand pressure line. Otherwise, system can be contaminated.

NOTE

To operate hydraulic test stand, refer to applicable manual.

1. Working from ramp, disconnect tube (1) of return control module (2) from tee fitting (3). Install pressure cap (4) in tee.
2. Working at right engine, disconnect ENG START PRESS hose (5) from fitting (6) on right engine disconnect shelf (7).
3. Connect return hose (8) from test stand to fitting (6).
4. Working at left engine, disconnect ENG START RET hose (9) from fitting (10) on left engine disconnect shelf (11).
5. Connect pressure hose (12) from test stand to fitting (10).
6. Apply hydraulic power. Set stand to **10 gpm at 500 psi**. Flush system for **15 minutes**. Check for leaks.

CAUTION

Do not exceed **500 psi**. Otherwise, damage to components can occur.

CAUTION

Keep test stand bypass valve closed. Otherwise, contaminants could re-enter the system.

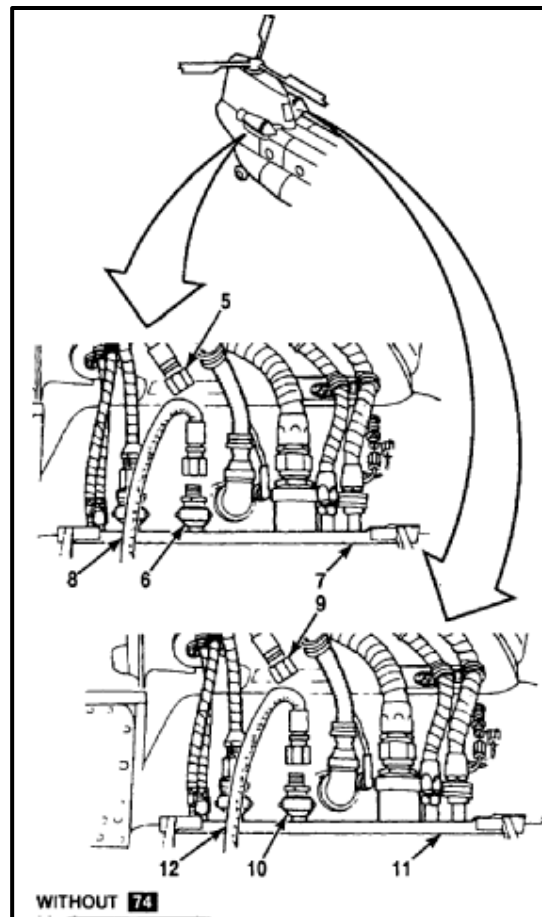
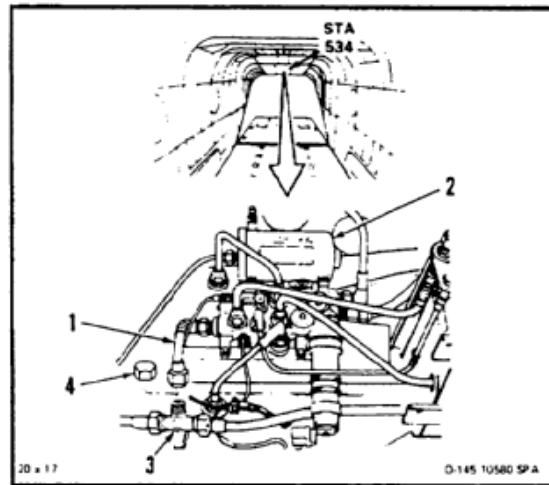

7. Remove hydraulic power.
8. Disconnect hose (12) from fitting (10). Use container and cloths (E135) for spilled fluid. Use gloves (E184.1).
9. Connect hose (9) to fitting (10).
10. Disconnect hose (8) from fitting (6). Use container and cloths (E135) for spilled fluid.
11. Connect hose (5) to fitting (6).

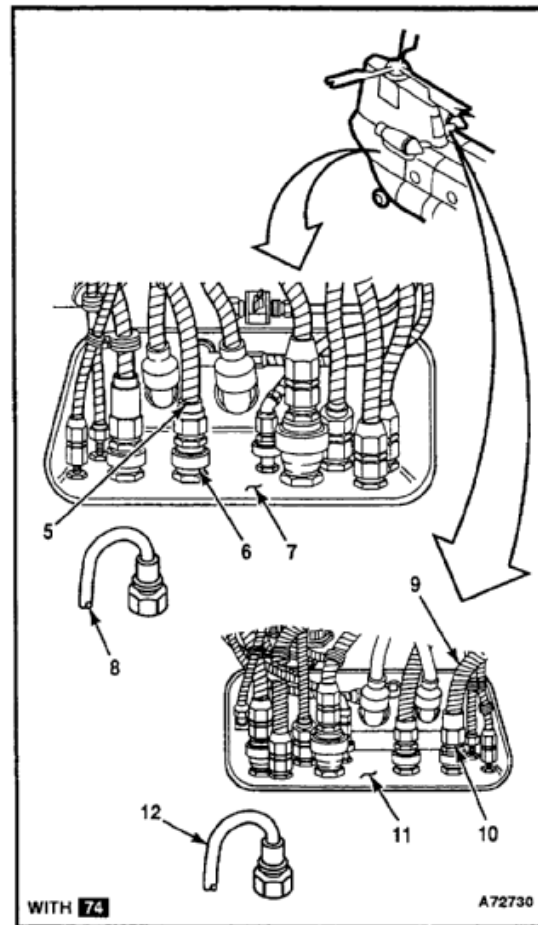

FOLLOW-ON MAINTENANCE:

Close left and right engine lower access covers (Task 4-50).

Perform operational check of engine start system (TM 55-1520-240-T).

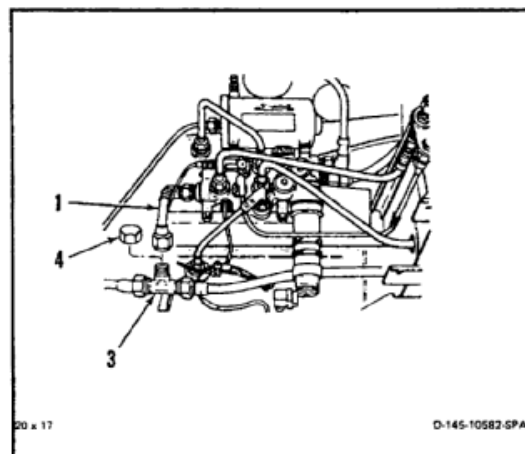

END OF TASK

7-1134

INITIAL SETUP

Applicable Configurations:

All

Tools:

- Hydraulic Repairer's Tool Kit, NSN 5180-00-323-4891
- Hoses
- Test Stand

Materials:

- Gloves (E186)
- Cloths (E135)

Personnel Required:

- Aircraft Pneudraulics Repairer (2)
- Inspector

Equipment Condition:

- Battery Disconnected (Task 1-39)
- Electrical Power Off
- Hydraulic Power Off
- Utility Hydraulic System Depressurized (Task 7-135.1)
- Center Tunnel Access Doors Open (Task 2-2)
- Cargo Ramp Open and Level (TM 55-1520-240-T)
- Aft Left Access Panel Open (Task 2-2)

- Forward Right Work Platform Open (Task 2-2)
- Rescue Hatch Open (Task 2-2)
- Forward Transmission Aft Fairing Removed (Task 2-63)
- Heater Compartment Acoustic Blanket Removed (Task 2-208)

General Safety Instructions:

WARNING

Hydraulic fluid (E199) is toxic. It can irritate skin and cause burns. Avoid inhaling. Use only with adequate ventilation. Avoid contact with skin, eyes, or clothing. In case of contact, immediately flush skin or eyes with water for at least **15 minutes**. Get medical attention for eyes.

WARNING

Hydraulic fluid ejected under pressure can cause injury to personnel. Hydraulic fluid sprayed into the air is a fire hazard.

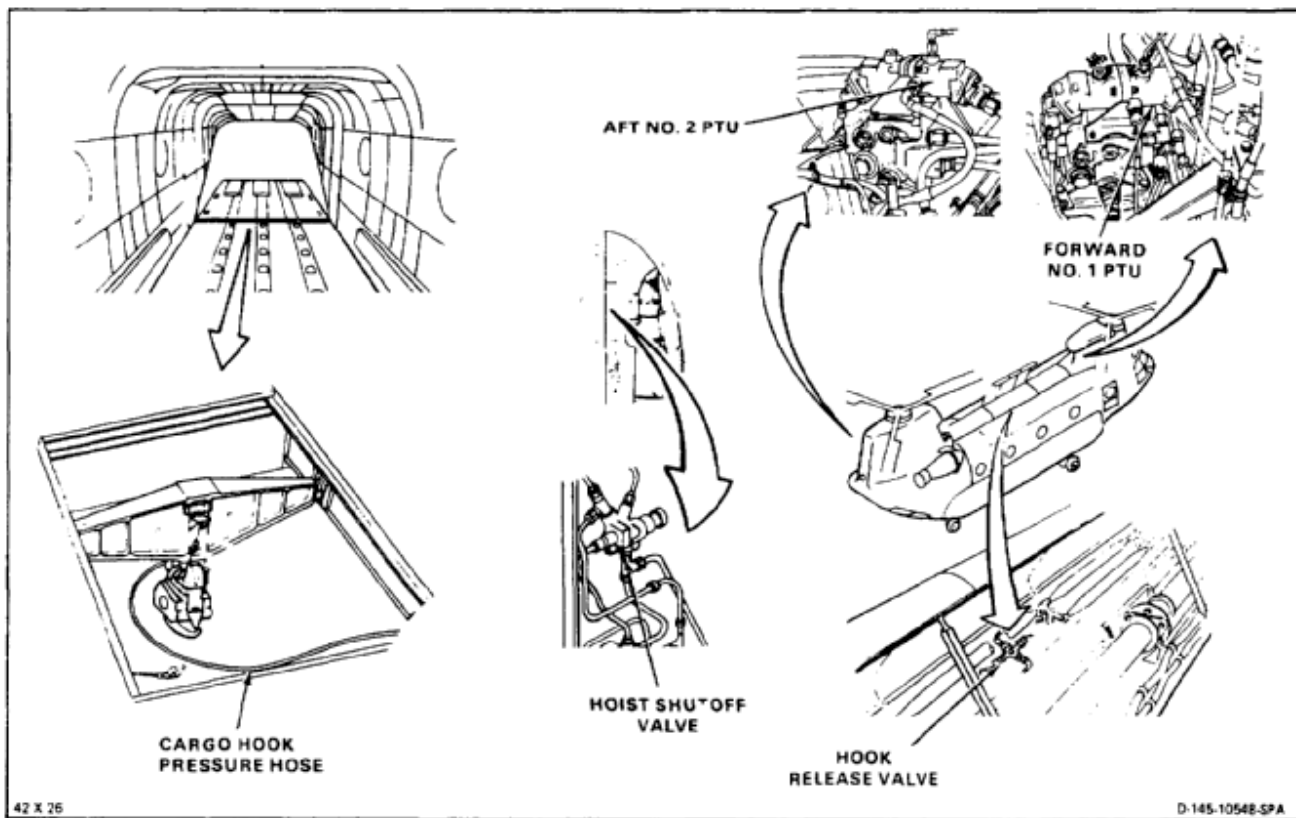

CAUTION

Filter assembly kit ADHT6814-M9716M must be installed in test stand pressure line.

NOTE

To operate hydraulic test stand, refer to applicable manual.

1. Working from ramp, disconnect PTU PRESS tube (1) from control module (2). Use gloves (E186).
2. Connect test stand pressure hose (3) to tube (1).
3. Working from aft left pylon, disconnect tube (4) from PTU PRESS port (5).
4. Install plug (6) in tube (4).

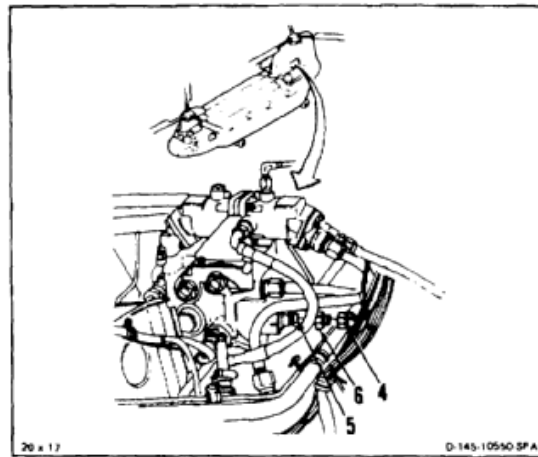
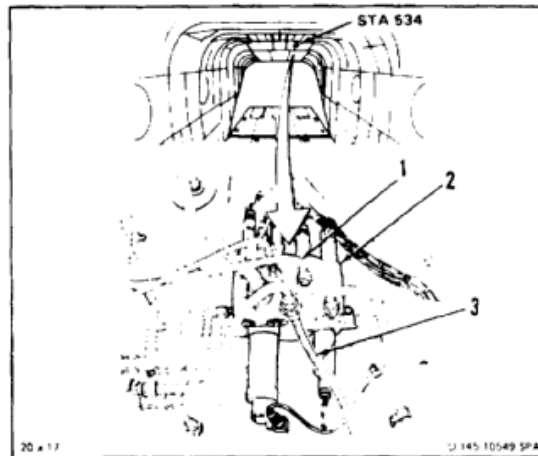

5. Working from center tunnel, disconnect two tubes (7 and 8) from hook release valve (9).
6. Connect hose (10) to tube (7).
7. Connect hose (10) to tube (8).

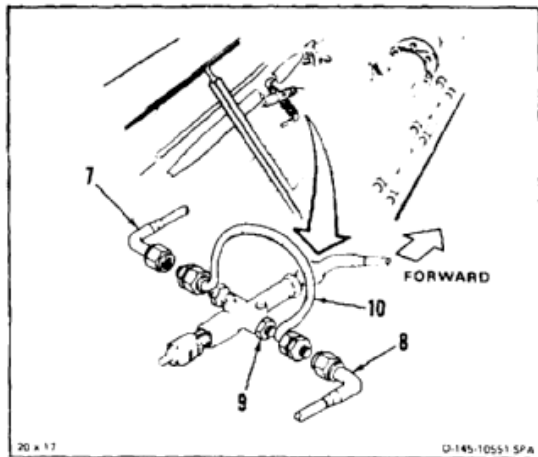

8. Working from forward right work platform, disconnect tube (11) from tee fitting (12) of PTU pressure tubing.
9. Install plug (13) in tee (12).

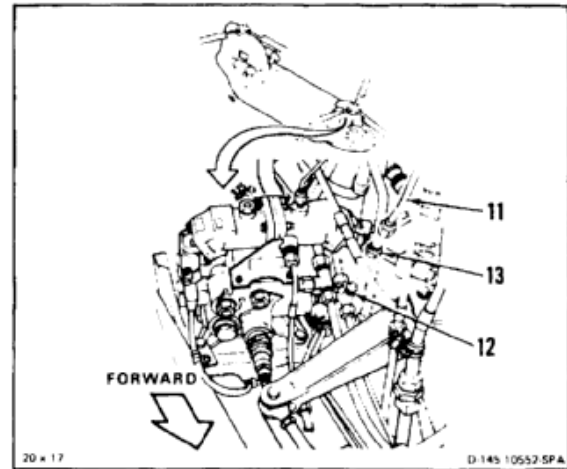

10. Working from center cabin, disconnect hose (14) at quick-disconnect (15).

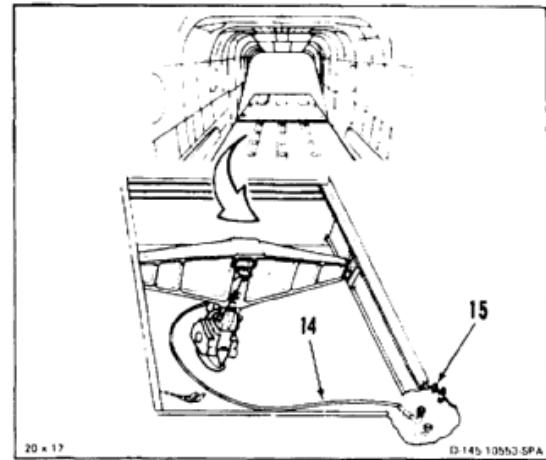

11. Working in heater compartment, disconnect tube (16) from hoist shutoff valve (17) pressure port (18).
12. Connect stand return valve (19) to port (18) of valve (17).



Do not exceed **500 psi**. Otherwise, damage to components can occur.



Keep test stand bypass valve closed. Otherwise, contaminants could re-enter the system.

13. Apply hydraulic power. Set stand to **10 gpm at 500 psi**. Flush system for **15 minutes**. Check for leaks.
14. Remove hydraulic power.
15. Disconnect hose (19) from port (18) of valve (17). Use container and cloths (E135) for spilled fluid.
16. Connect tube (16) to port (18) of valve (17).

INSPECT

17. Working from aft left pylon, remove plug (6) from tube (4).
18. Connect stand return hose (19) to tube (4).
19. Apply hydraulic power. Set stand to **10 gpm at 500 psi**. Flush system for **15 minutes**. Check for leaks.
20. Remove hydraulic power.
21. Disconnect hose (19) from tube (4). Use container and cloths (E135) for spilled fluid.
22. Connect tube (4) to PTU PRESS port (5).

INSPECT

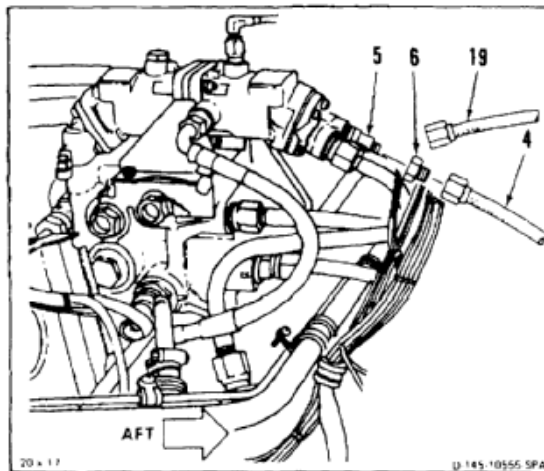
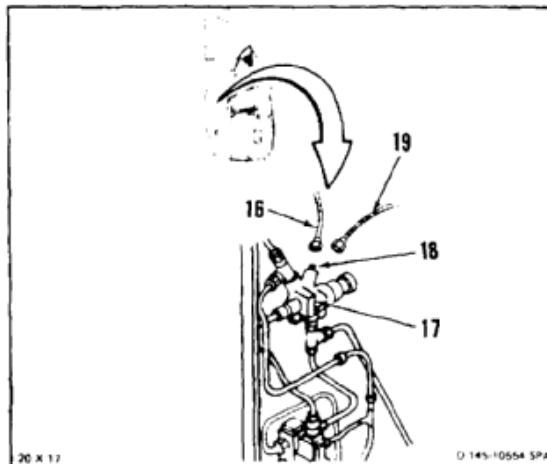

- 23. Working from center cabin, connect stand return hose (19) to quick-disconnect (15) of cargo hook hose (14).



Do not exceed **500 psi**. Otherwise, damage to components can occur.



Keep test stand bypass valve closed. Otherwise, contaminants could re-enter the system.

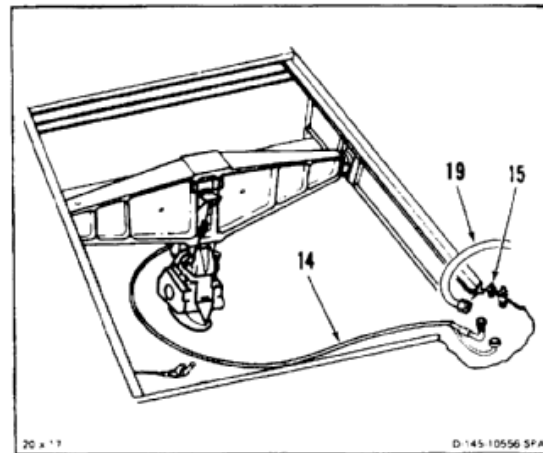

- 24. Apply hydraulic power. Set stand to **10 gpm at 500 psi**. Flush system for **15 minutes**. Check for leaks.
- 25. Remove hydraulic power.
- 26. Disconnect hose (19) from quick-disconnect (15). Use container and cloths (E135) for spilled fluid.
- 27. Connect hose (14) to quick-disconnect (15).

INSPECT

- 28. Working from forward right work platform, remove plug (13) from tee (12).
- 29. Connect PTU pressure tube (11) to tee (12).

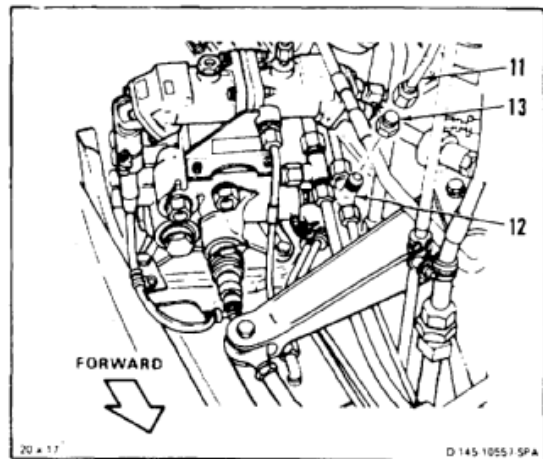

- 30. Working from center tunnel, disconnect hose (10) from two tubes (7 and 8) of valve (9).
- 31. Connect tube (7) to valve (9).
- 32. Connect tube (8) to valve (9).

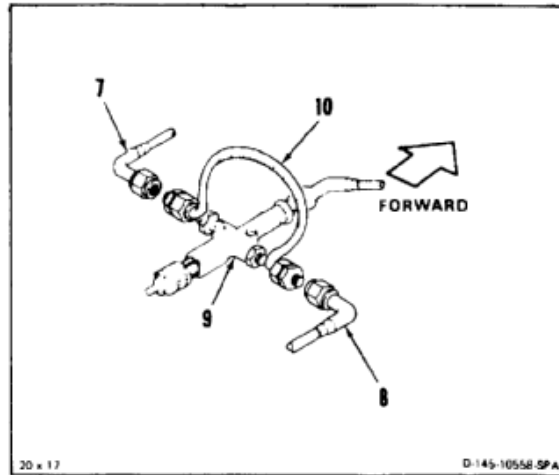

- 33. Working from ramp, connect PTU PRESS tube (1) to control module (2).

INSPECT

FOLLOW-ON MAINTENANCE:

- Perform operational check of No. 1 and No. 2 PTU and cargo hook system (TM 55-1520-240-T).
- Close forward work platform (Task 2-2).
- Close aft left access panel (Task 2-2).
- Close tunnel access doors (Task 2-2).
- Close rescue hatch (Task 2-2).
- Install heater closet acoustic blanket (Task 2-210).
- Install forward transmission aft fairing (Task 2-68).

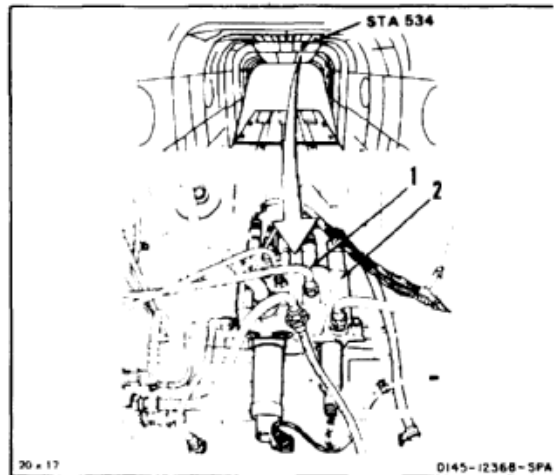

END OF TASK

INITIAL SETUP

Applicable Configurations:

All

Tools:

- Hydraulic Repairer's Tool Kit, NSN 5180-00-323-4891
- Test Stand
- Hoses
- Container, 2 Quart

Materials:

- Cloths (E135)
- Gloves (E186)

Personnel Required:

- Aircraft Pneudraulics Repairer (2)
- Inspector

Equipment Condition:

- Battery Disconnected (Task 1-39)
- Electrical Power Off
- Hydraulic Power Off
- Utility Hydraulic System Depressurized (Task 7-135.1)
- Tunnel Center Access Door Open (Task 2-2)

- Forward Right Work Platform Open (Task 2-2)
- Ramp Open and Level (TM 55-1520-240-T)
- Forward Transmission Aft Fairing Removed (Task 2-63)
- Aft Left Access Panel Open (Task 2-2)

General Safety Instructions:

WARNING

Hydraulic fluid (E199) is toxic. It can irritate skin and cause burns. Avoid inhaling. Use only with adequate ventilation. Avoid contact with skin, eyes, or clothing. In case of contact, immediately flush skin or eyes with water for at least **15 minutes**. Get medical attention for eyes.

WARNING

Hydraulic fluid ejected under pressure can cause injury to personnel. Hydraulic fluid sprayed into the air is a fire hazard.

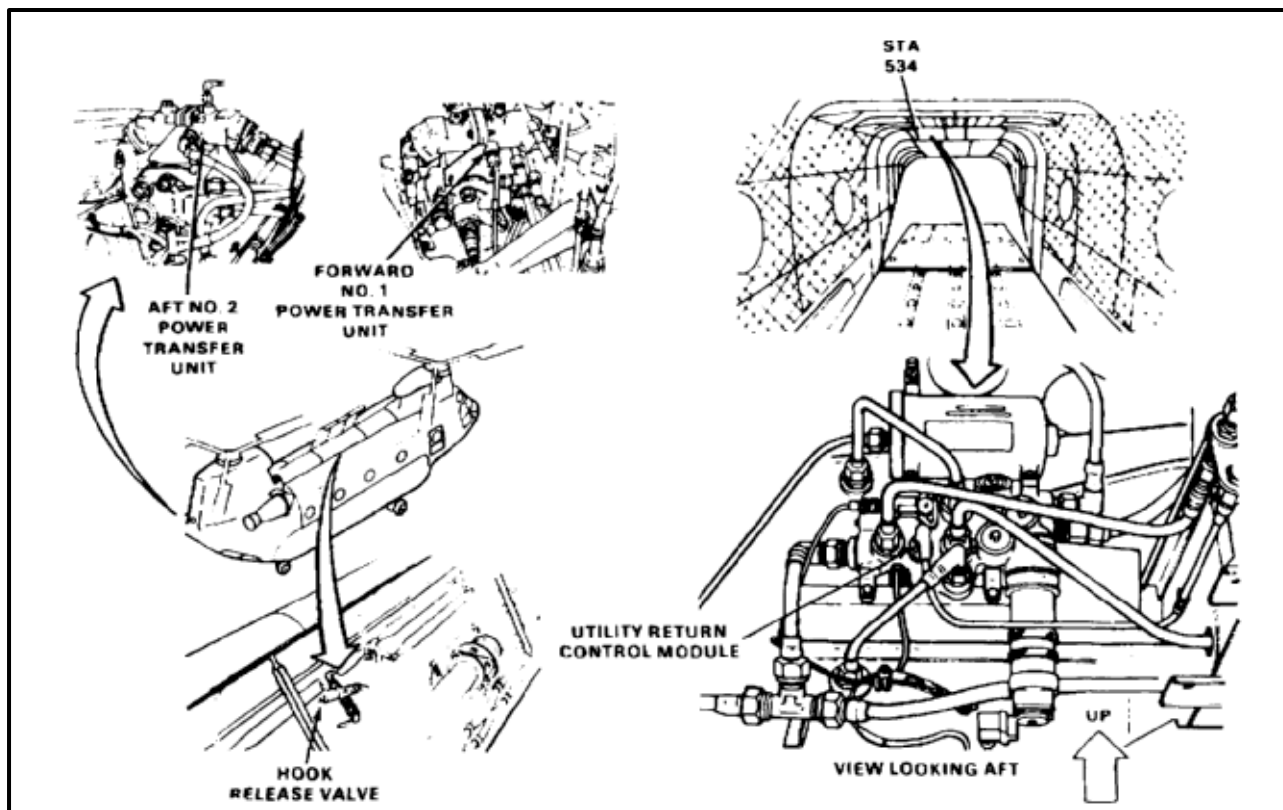

CAUTION

Filter assembly Kit
ADHT6814-M9716M must be
installed in test stand pressure line.

NOTE

To operate hydraulic test stand refer
to applicable manual.

1. Working from ramp, disconnect PTU RTN tube (1) from control module (2).
2. Connect test stand pressure hose (3) to tube (1).

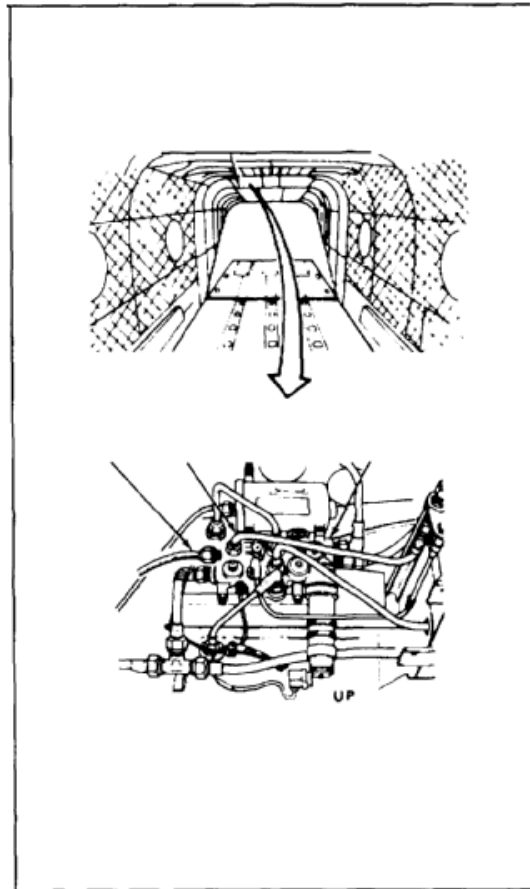

3. Working from aft left pylon disconnect tube (4) from PTU RTN port (5).
4. Install plug (6) in tube (4).

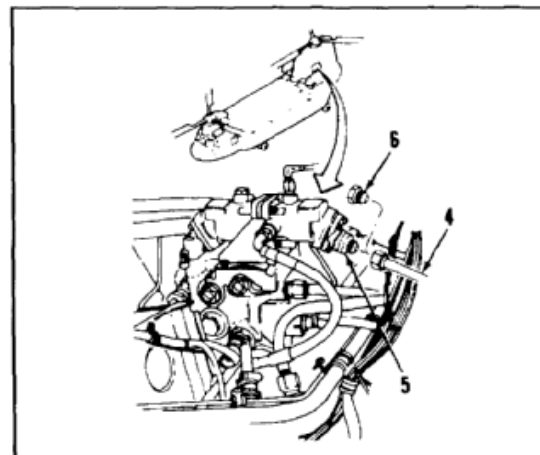

5. Working from forward right work platform, disconnect tube (7) from tee fitting (8) of PTU return tubing.
6. Install plug (9) in tee (8).

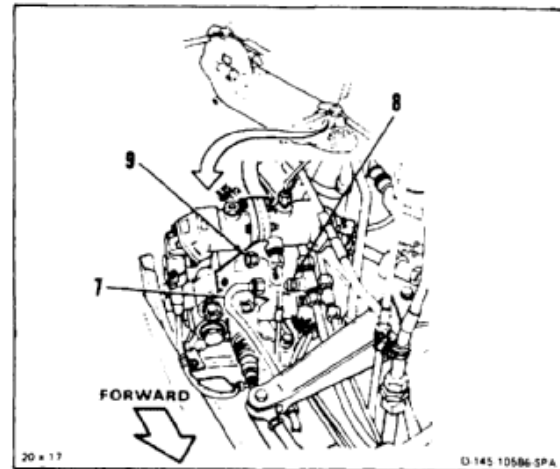

7. Working in heater compartment, disconnect tube (10) from tee fitting (11) of hoist shutoff valve (12).
8. Connect stand return hose (13) to tee (11) of valve (12).



Do not exceed **500 psi**. Otherwise, damage to components can occur.



Keep test stand bypass valve closed. Otherwise, contaminants could re-enter the system.

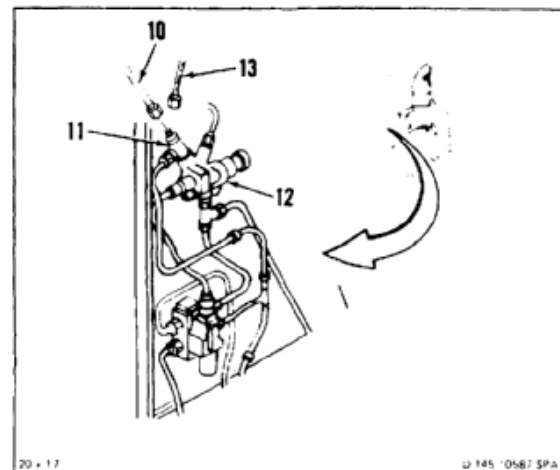

9. Apply hydraulic power. Set stand to **10 gpm at 500 psi**. Flush system for **15 minutes**. Check for leaks.
10. Remove hydraulic power.
11. Disconnect hose (13) from tee (11) of valve (12). Use container and cloths (E135) for spilled fluid.
12. Connect tube (10) to tee (11).

INSPECT

13. Working through aft left access panel, remove plug (6) from tube (4).
14. Connect hose (13) to tube (4).



Do not exceed **500 psi**. Otherwise, damage to components can occur.



Keep test stand bypass valve closed. Otherwise, contaminants could re-enter the system.

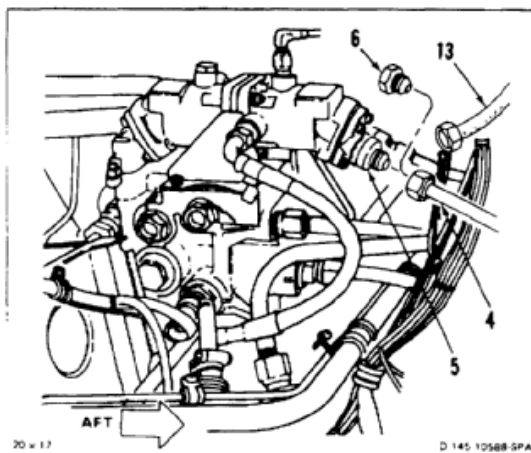

15. Apply hydraulic power. Set stand to **10 gpm at 500 psi**. Flush system for **15 minutes**. Check for leaks.
16. Remove hydraulic power.
17. Disconnect hose (13) from tube (4). Use container and cloths (E135) for spilled fluid. Wear gloves (E186).
18. Connect tube (4) to PTU RTN port (5).

INSPECT

19. Working from forward right work platform, remove plug (9) from tee (8).
20. Connect hose (13) to tee (8).



Do not exceed **500 psi**. Otherwise, damage to components can occur.



Keep test stand bypass valve closed. Otherwise, contaminants could re-enter the system.

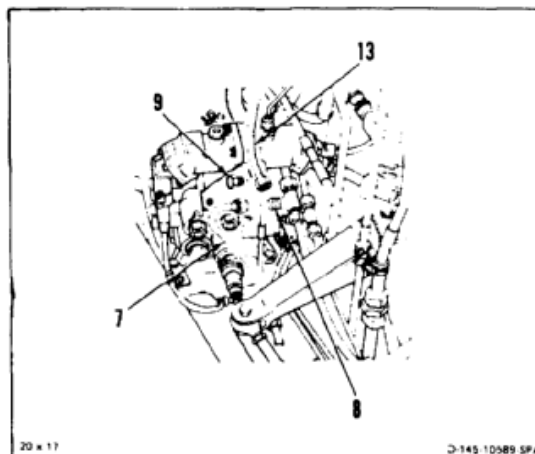

21. Apply hydraulic power. Set stand to **10 gpm at 500 psi**. Flush system for **15 minutes**. Check for leaks.
22. Remove hydraulic power.
23. Disconnect hose (13) from tee (8). Use container and cloths (E135) for spilled fluid.
24. Connect tube (7) to tee (8).

25. Working from center tunnel, disconnect tube (14) from hook release valve (15).
26. Connect hose (13) to valve (15).



Do not exceed **500 psi**. Otherwise, damage to components can occur.



Keep test stand bypass valve closed. Otherwise, contaminants could re-enter the system.

27. Apply hydraulic power. Set stand to **10 gpm at 500 psi**. Flush system for **15 minutes**. Check for leaks.
28. Remove hydraulic power.
29. Disconnect hose (13) from valve (15). Use container and cloths (E135) for spilled fluid.
30. Connect tube (14) to valve (15).

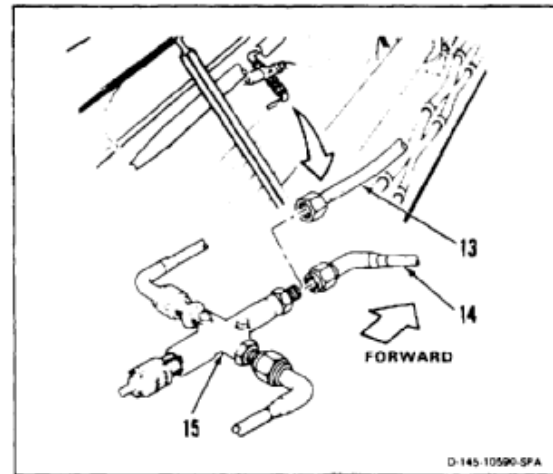

INSPECT

31. Working from ramp, disconnect hose (3) from tube (1). Use container and cloths (E135) for spilled fluid.
32. Connect tube (1) to PTU RTN port (16) of control module (2).

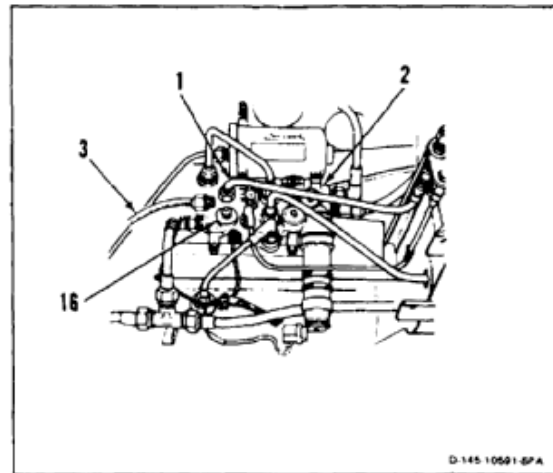

INSPECT

FOLLOW-ON MAINTENANCE:

- Perform operational check of No. 1 and No. 2 PTU and cargo hook system (TM 55-1520-240-T).
- Close forward work platforms (Task 2-2).
- Close tunnel access doors (Task 2-2).
- Install forward transmission aft fairing (Task 2-68).
- Close aft left access panel (Task 2-2).

END OF TASK

INITIAL SETUP

Applicable Configurations:

All

Tools:

Hydraulic Repairer's Tool Kit, NSN 5180-00-323-4891
 Container, 2 Quart
 Test Stand

Materials:

Paper Tags (E264)
 Cloths (E120)
 Gloves (E186)

Personnel Required:

Aircraft Pneudraulics Repairer (2)
 Inspector

Equipment Condition:

Battery Disconnected (Task 1-39)
 Electrical Power Off
 Hydraulic Power Off
 Utility Hydraulic System Depressurized (Task 7-135.1)
 Heater Compartment Acoustic Blanket Removed
 (Task 2-208)
 Hoist Control Valve Removed (Task 7-249)
 Hoist Pressure Reducer Removed (Task 7-255)

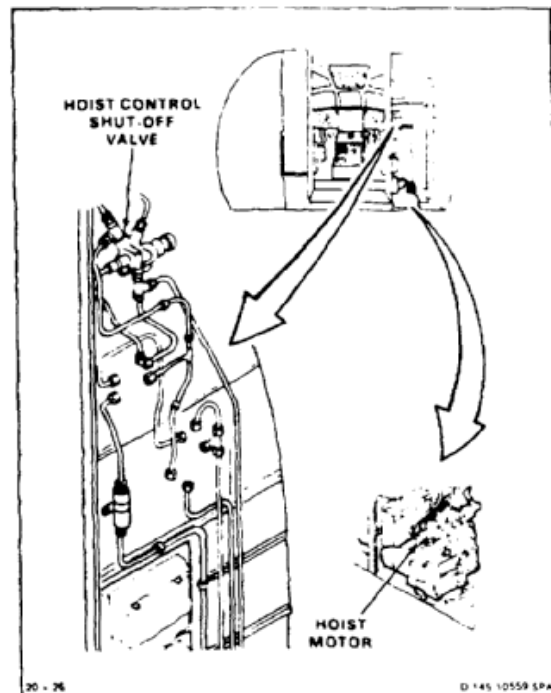
**General Safety instructions:****WARNING**

Hydraulic fluid (E199) is toxic. It can irritate skin and cause burns. Avoid inhaling. Use only with adequate ventilation. Avoid contact with skin, eyes, or clothing. In case of contact, immediately flush skin or eyes with water for at least **15 minutes**. Get medical attention for eyes.

WARNING

Hydraulic fluid ejected under pressure can cause injury to personnel.
 Hydraulic fluid sprayed into the air is a fire hazard.

CAUTION

Filter assembly kit ADHT6814-M9716M must be installed in test stand pressure line.

NOTE

To operate hydraulic test stand, refer to applicable manual.

1. Disconnect tee fitting (1) from port (2) of hoist control shutoff valve (3).
2. Connect test stand pressure hose (4) to tee (1).
3. Disconnect tube (5) from tee (1).
4. Install cap (6) in tee (1).
5. Connect test stand return hose (7) to tube (5).
6. Connect hose (8) to tube (9).
7. Connect hose (8) to tube (10).
8. Install plug (11) in tube (12).
9. Install plug (13) in tube (14).
10. Connect hose (15) to tube (10).
11. Connect hose (15) to tube (16).
12. Install plug (17) in tee (18).

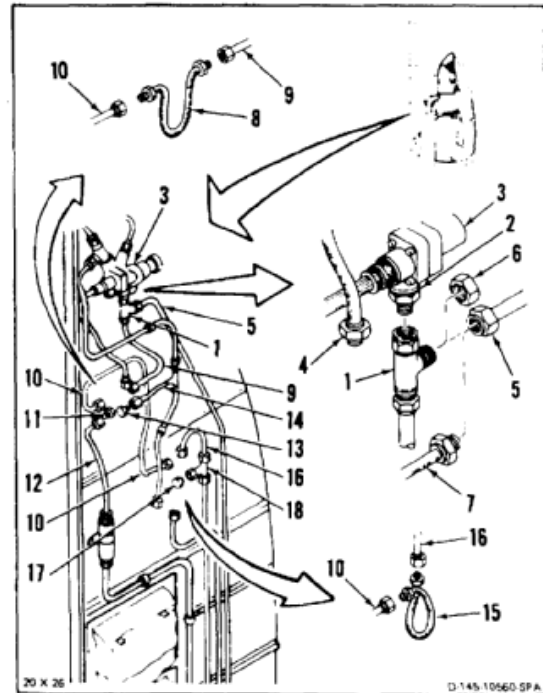

CAUTION

Do not disconnect **1/4 inch** hose from hoist motor.

13. Tag and disconnect two hoses (19 and 20) from hoist motor (21).
14. Connect hose (19) to hose (20).

CAUTION

Do not exceed **500 psi**. Otherwise, damage to components can occur.

CAUTION

Keep test stand bypass valve closed. Otherwise, contaminants could re-enter the system.

15. Apply hydraulic power. Set stand to **10 gpm at 500 psi**. Flush system for **15 minutes**. Check for leaks.
16. Remove hydraulic power.

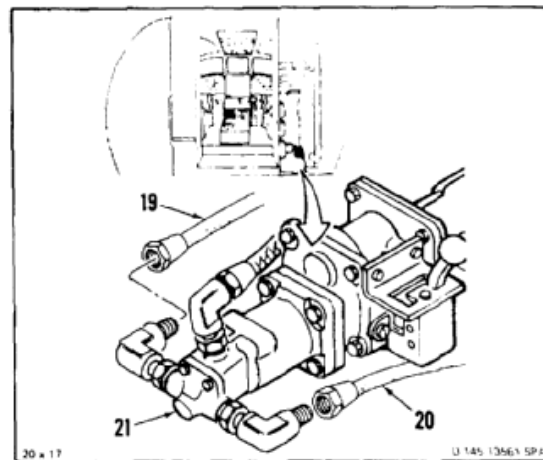

17. Disconnect hose (4) from tee (1). Use cloths (E120) and container for spilled fluid.
18. Disconnect hose (7) from tube (5). Use cloths (E120) and container for spilled fluid. Use gloves (E186).
19. Remove cap (6) from tee (1).
20. Connect tube (5) to tee (1).
21. Disconnect hose (8) from two tubes (9 and 10).
22. Remove plug (11) from tube (12).
23. Remove plug (13) from tube (14).
24. Disconnect hose (15) from two tubes (10 and 16).
25. Remove plug (17) from tee (18).

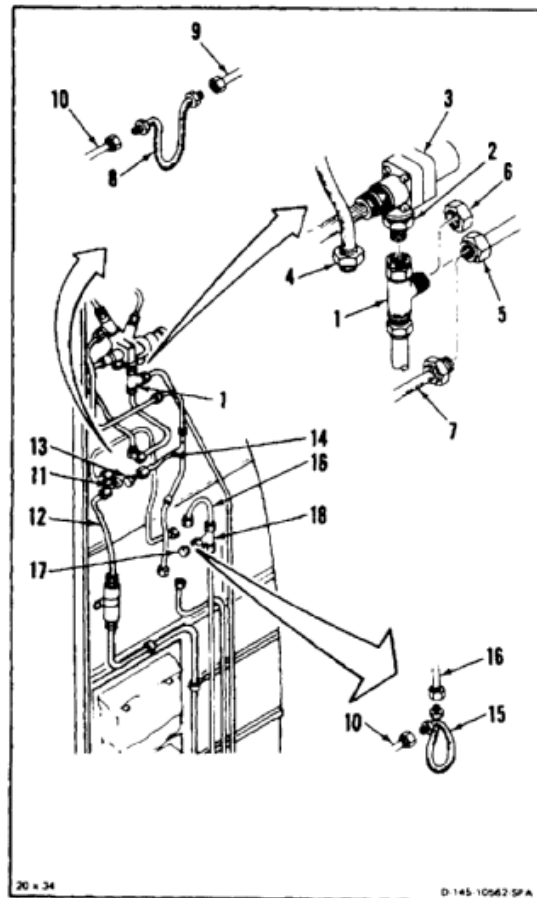

26. Connect HOIST DOWN hose (19) to port (22) of motor (21). Remove tag.
27. Connect HOIST UP hose (20) to port (23) of motor (21). Remove tag.

INSPECT**FOLLOW-ON MAINTENANCE:**

- Install control valve (Task 7-250).
- Install pressure reducer (Task 7-259).
- Perform operational check of hoist control (TM 55-1520-240-T).
- Install heater compartment acoustic blanket (Task 2-210).

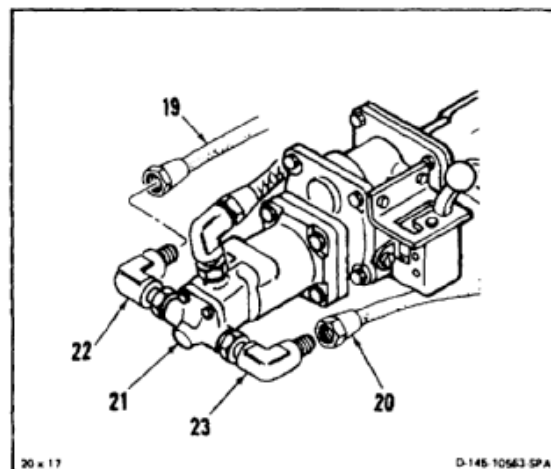

END OF TASK

7-1148

INITIAL SETUP

Applicable Configurations:

All

Tools:

Hydraulic Repairer's Tool Kit, NSN 5180-00-323-4891
 Test Stand
 Hoses
 Container, 2 Quart

Materials:

Cloths (E120)
 Gloves (E186)

Personnel Required:

Aircraft Pneudraulics Repairer (2)
 Inspector

Equipment Condition:

Battery Disconnected (Task 1-39)
 Electrical Power Off
 Hydraulic Power Off
 Utility Hydraulic System Depressurized (Task 7-135.1)
 Heater Compartment Acoustic Blanket Removed
 (Task 2-208)
 Hoist Control Valve Removed (Task 7-249)
 Hoist Pressure Reducer Removed (Task 7-255)

General Safety Instructions:**WARNING**

Hydraulic fluid (E199) is toxic. It can irritate skin and cause burns. Avoid inhaling. Use only with adequate ventilation. Avoid contact with skin, eyes, or clothing. In case of contact, immediately flush skin or eyes with water for at least **15 minutes**. Get medical attention for eyes.

WARNING

Hydraulic fluid ejected under pressure can cause injury to personnel.
 Hydraulic fluid sprayed into the air is a fire hazard.

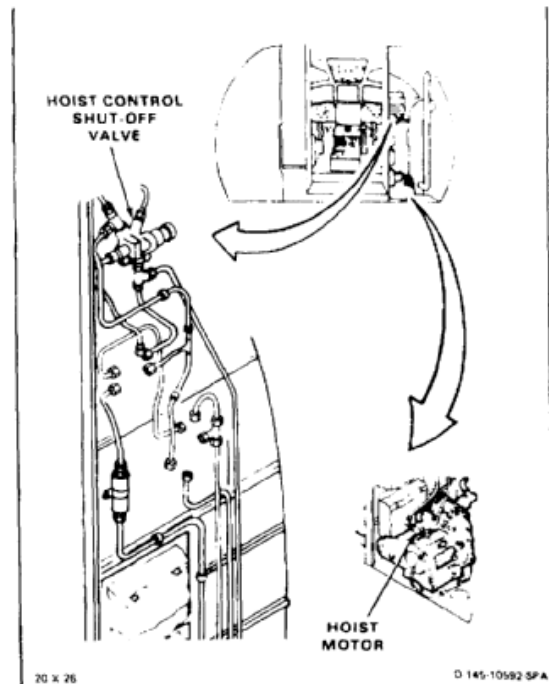

CAUTION

Filter assembly kit
ADHT6814-M9716M must be
installed in test stand pressure line.

NOTE

To operate hydraulic test stand, refer
to applicable manual.

1. Disconnect tube (1) from tee (2).
2. Connect test stand pressure hose (3) to tube (1).
3. Disconnect tube (1) from relief valve (4).
4. Connect hose (5) to tube (1).
5. Disconnect CD hose (6) from motor (7).
6. Connect hose (5) to hose (6).
7. Connect test stand return hose (8) to tube (9).
8. Install plug (10) to tube (11).

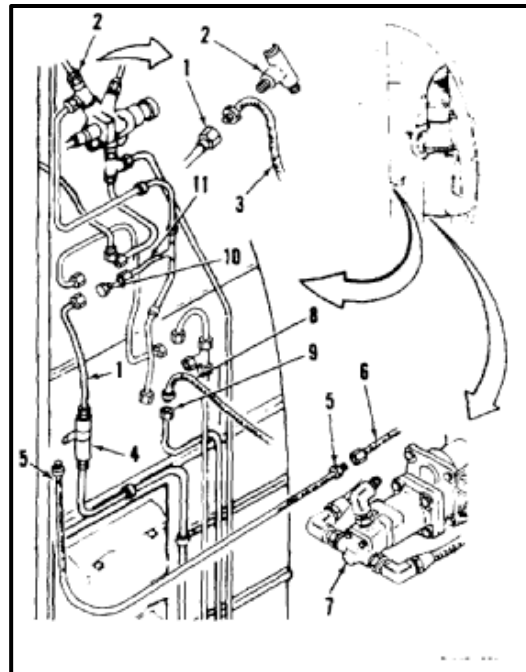
**CAUTION**

Do not exceed **500 psi**. Otherwise
damage to components can occur.

CAUTION

Keep test stand bypass valve closed.
Otherwise, contaminants could
re-enter the system.

9. Apply hydraulic power. Set stand to **10 gpm at 500 psi**. Flush system for **15 minutes**. Check for leaks.
10. Remove hydraulic power.

11. Disconnect hose (8) from tube (9). Use cloths (E120) and container for spilled fluid. Use gloves (E186).
12. Install plug (12) in tube (9).
13. Remove plug (10) from tube (11).
14. Connect hose (8) to tube (11).

CAUTION

Do not exceed **500 psi**. Otherwise damage to components can occur.

CAUTION

Keep test stand bypass valve closed. Otherwise, contaminants could re-enter the system.

15. Apply hydraulic power. Set stand to **10 gpm at 500 psi**. Flush system for **15 minutes**. Check for leaks.
16. Remove hydraulic power.

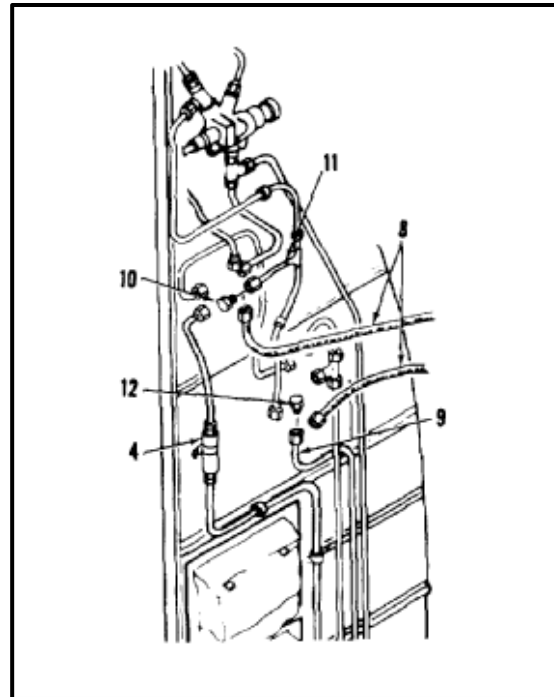

17. Disconnect hose (5) from tube (1).
18. Install tube (1) in valve (4).
19. Disconnect hose (5) from hose (6). Use cloths (E120) and containers for spilled fluid.
20. Connect hose (6) to motor (7).

CAUTION

Do not exceed **500 psi**. Otherwise damage to components can occur.

CAUTION

Keep test stand bypass valve closed. Otherwise, contaminants could re-enter the system.

21. Apply hydraulic power. Set stand to **10 gpm at 500 psi**. Flush system for **15 minutes**. Check for leaks.
22. Remove hydraulic power.
23. Remove plug (12) from tube (9).
24. Disconnect hose (8) from tube (11). Use cloths (E120) and container for spilled fluid.
25. Remove hose (3) from tube (1). Use cloths (E120) and container for spilled fluid.
26. Connect tube (1) to tee (2).

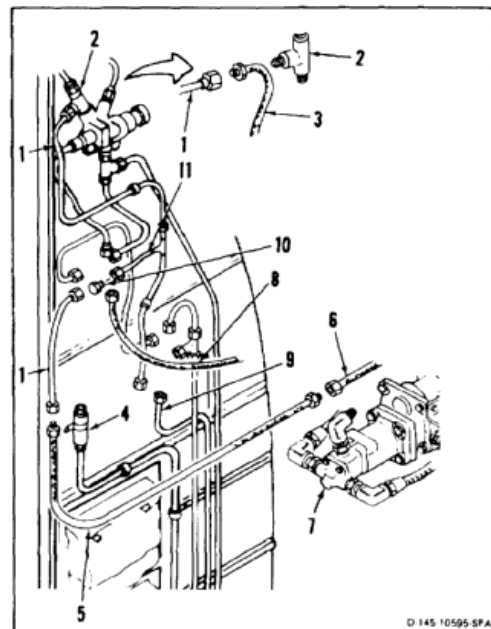

INSPECT

FOLLOW-ON MAINTENANCE:

- Install control valve (Task 7-250).
- Install pressure reducer (Task 7-259).
- Perform operational check of hoist control (TM 55-1530-240-T).
- Install heater compartment acoustic blanket (Task 2-210).

END OF TASK

7-1152

INITIAL SETUP

General Safety Instructions:

Applicable Configurations:

All

Tools:

- Hydraulic Repairer's Tool Kit, NSN 5180-00-323-4891
- Hydraulic Test Stand
- Hoses
- Container, 2 Quart
- Workstand

Materials:

- Cloths (E120)
- Paper Tags (E264)
- Gloves (E186)

Personnel Required:

- Aircraft Pseudraulics Repairer (2)
- Inspector

Equipment Condition:

- Battery Disconnected (Task 1-39)
- Electrical Power Off
- Hydraulic Power Off
- Utility Hydraulic System Depressurized (Task 7-135.1)
- APU Start Accumulator Removed (Task 7-148)
- Cargo Ramp Down and Level (TM 55-1520-240-T)
- Right Pylon Door Open (Task 2-2)

WARNING

Hydraulic fluid (E199) is toxic. It can irritate skin and cause burns. Avoid inhaling. Use only with adequate ventilation. Avoid contact with skin, eyes, or clothing. In case of contact, immediately flush skin or eyes with water for at least **15 minutes**. Get medical attention for eyes.

WARNING

Hydraulic fluid ejected under pressure can cause injury to personnel. Hydraulic fluid sprayed into the air is a fire hazard.

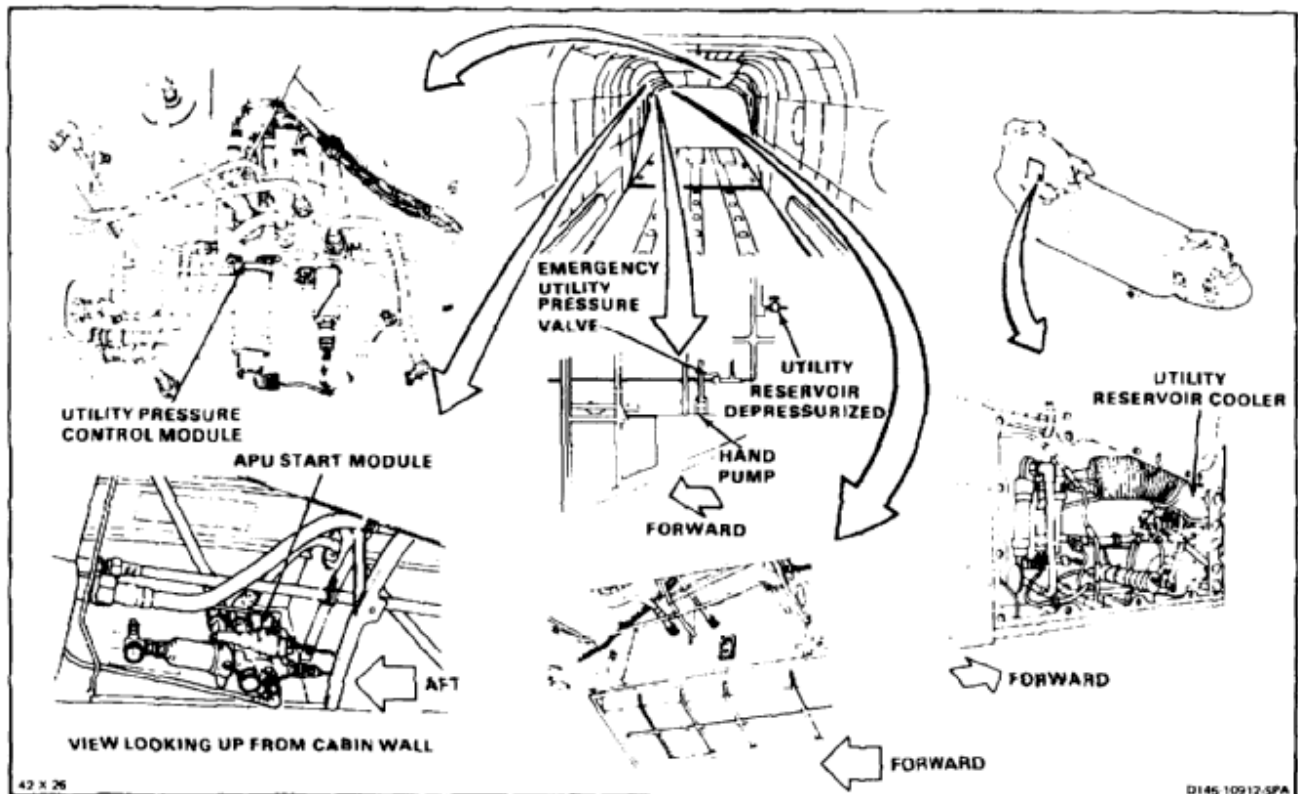

CAUTION

Filter assembly kit ADHT6814-M9716M must be installed in test stand pressure lines.

NOTE

To operate hydraulic test stand refer to applicable manual.

1. Working from ramp, disconnect tube (1) from EXT POWER port (2) of power control module (3).
2. Disconnect tube (4) from PRESS IN ports (5) of module (3).
3. Connect hose (6) to tubes (1 and 4).
4. Disconnect tube (7) from RSVR PRESS port (8) of module (3).
5. Connect test stand return hose (9) to tube (7).

6. Tag and disconnect UTIL PUMP PRESS hose (10) from fitting (11) at sta. 540. Use container and cloths (E120) for spilled fluid. Use gloves (E186).
7. Install cap (12) on fitting (11).

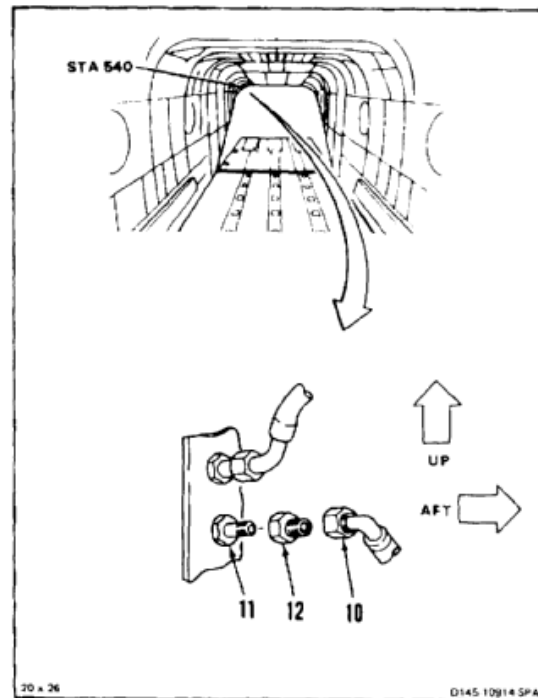
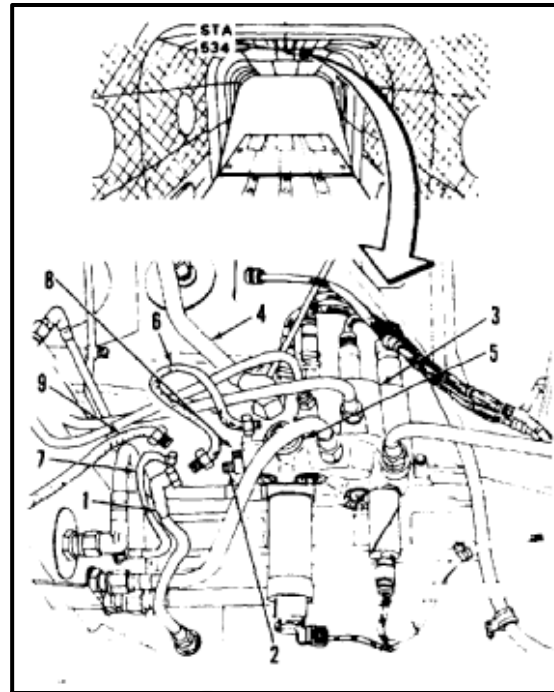

7-321 FLUSH GROUND TEST, PUMP, HAND PUMP, AND RESERVOIR PRESSURE TUBING (Continued)

7-321

8. Tag and disconnect tube (13) from tee (14).
9. Disconnect tube (13) from port (15) of APU START module (16). Remove tube.
10. Disconnect tube (17) from tee (14).
11. Connect end (18) of tube (13) to tube (17).

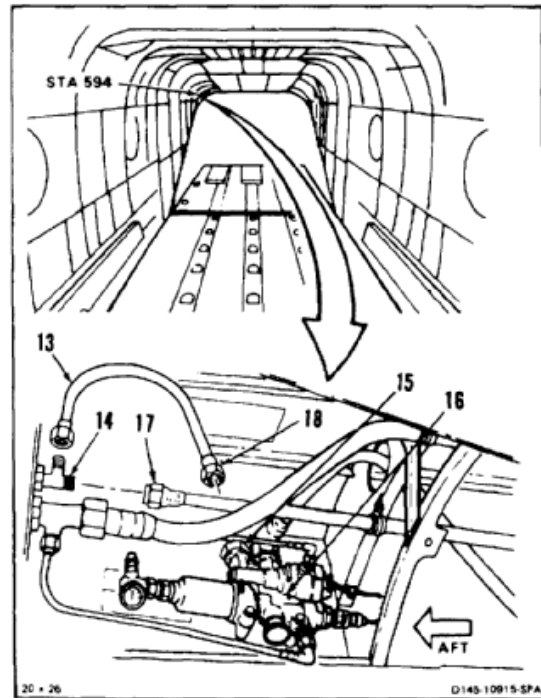

12. Disconnect tube (19) from APU PRESS port (20) of module (16).
13. Connect hose (21) to tubes (13 and 19).

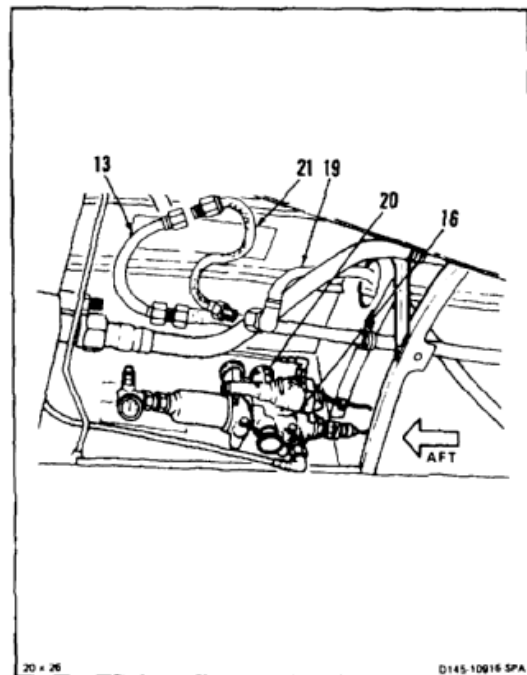

14. Remove four bolts (22) and washers (23) from accumulator mount (24). Disconnect two tees (25 and 26) from mount. Remove mount.
15. Install plug (27) in pressure tee (25).
16. Install plug (28) in return tee (26).

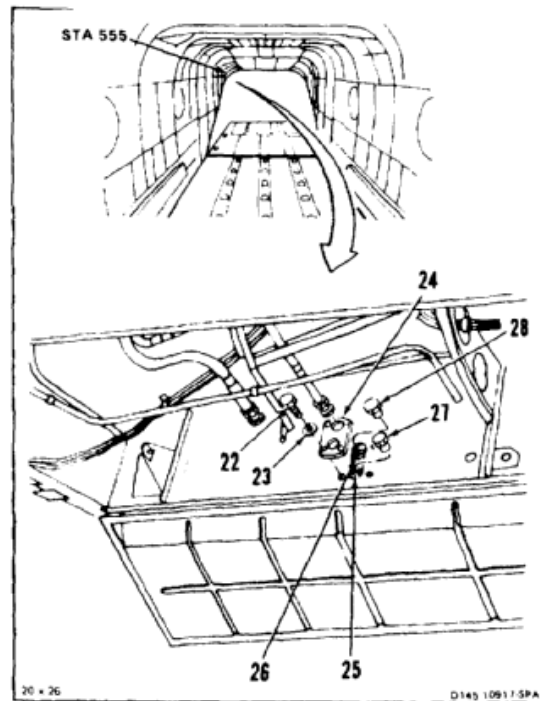

17. Disconnect fitting (29) from EMERG UTIL PRESS valve (30).
18. Disconnect tube (31) from valve (30).
19. Connect hose (32) to tube (31) and fitting (29).
20. Disconnect tubes (33 and 34) from UTIL RESERVOIR REPRESSURIZE valve (35).
21. Connect hose (36) to tubes (33 and 34).

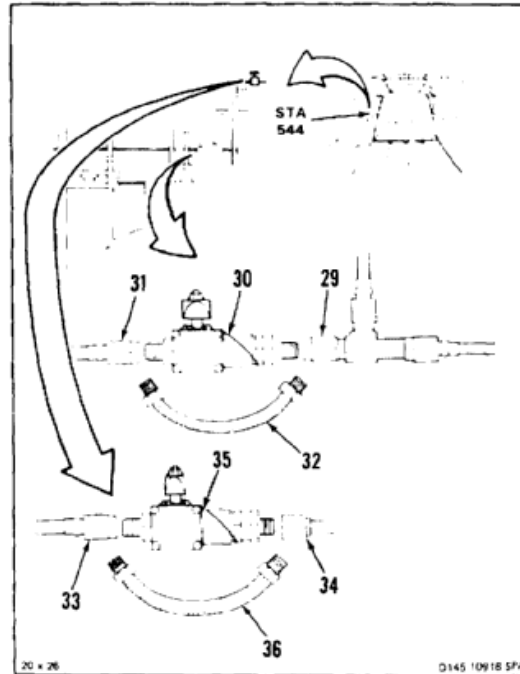

7-321 FLUSH GROUND TEST, PUMP, HAND PUMP, AND RESERVOIR PRESSURE TUBING (Continued)

7-321

- 22. Disconnect tube (37) from PRESS port (38) of hand pump (39).
- 23. Connect hose (40) length about **8 feet** to port (38) of pump (39). Route hose up through pylon to reservoir cooler (41) on right of pylon.
- 24. Working right of pylon, disconnect tube (42) from PRESS port (43) of reservoir (41).
- 25. Connect hose (40) to port (43) of reservoir (41).

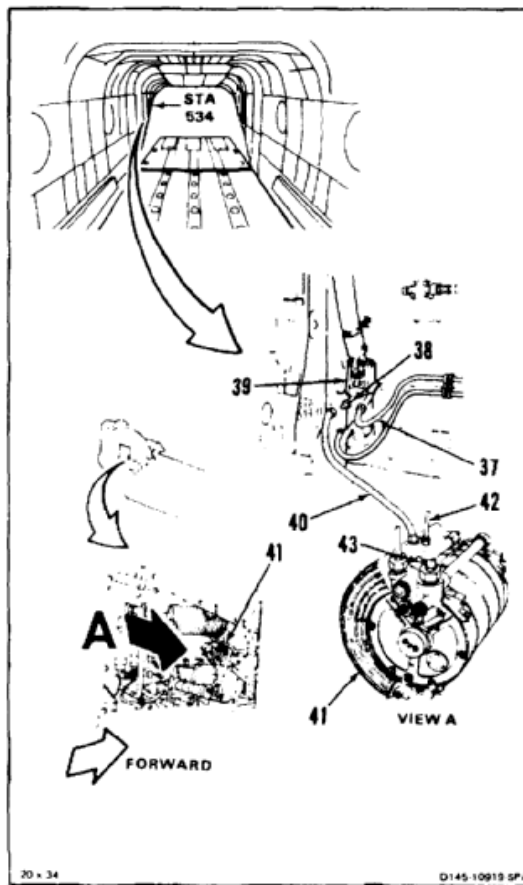

- 26. Disconnect tee fitting (44) from accumulator (45).
- 27. Install plug (46) in fitting (44).

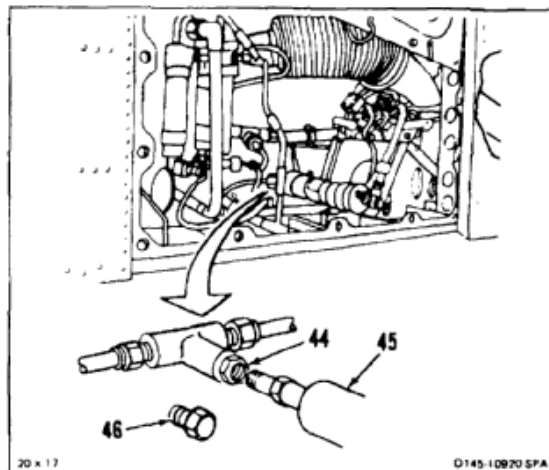

28. Working aft right side, remove cover (47) from utility PRESS ground disconnect fitting (48).
29. Connect test stand pressure hose (49) to fitting (48).



Do not exceed **500 psi**. Otherwise damage to components can occur.



Keep test stand bypass valve closed. Otherwise, contaminants could re-enter the system.

30. Apply hydraulic power. Set stand for **10 gpm at 500 psi**. Flush system for **15 minutes**. Check for leaks.
31. Remove hydraulic power.

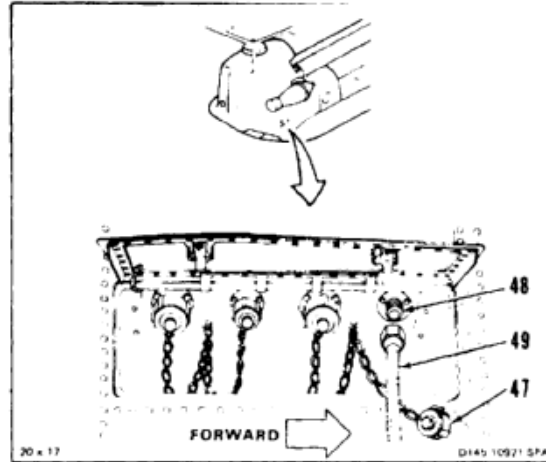

7-321 FLUSH GROUND TEST, PUMP, HAND PUMP, AND RESERVOIR PRESSURE TUBING (Continued)

7-321

- 32. Disconnect hose (49) from fitting (48). Use container and cloths (E120) for spilled fluid.
- 33. Install cover (47) on fitting (48).

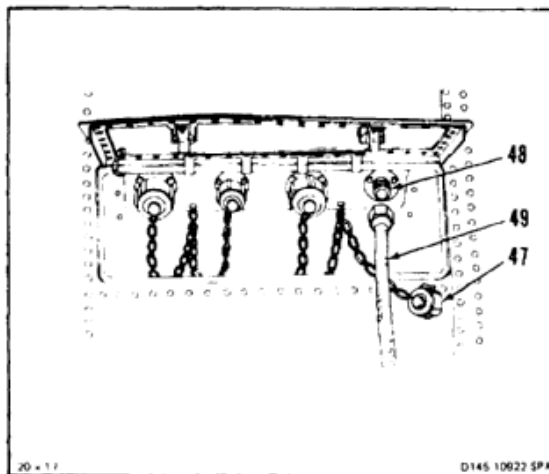

- 34. Working right of pylon, remove plug (46) from fitting (44).
- 35. Connect fitting (44) to accumulator (45).

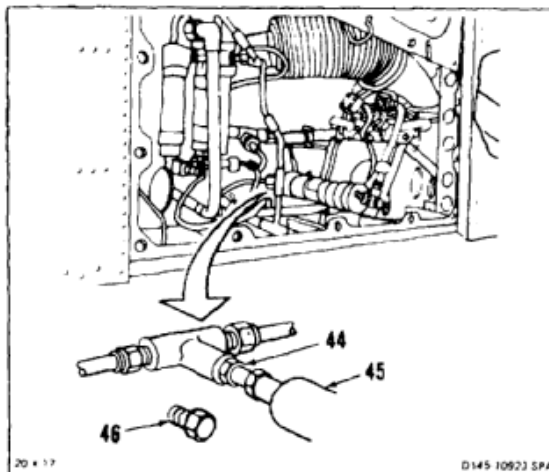

36. Disconnect hose (40) from port (43) of reservoir (41). Use cloths (E120) for spilled fluid.
37. Connect tube (42) to PRESS port (43) of reservoir (41).
38. Working from ramp, disconnect hose (40) from pump (39). Remove hose. Use container and cloths (E120) for spilled fluid.
39. Connect tube (37) to PRESS port (38) of pump (39).

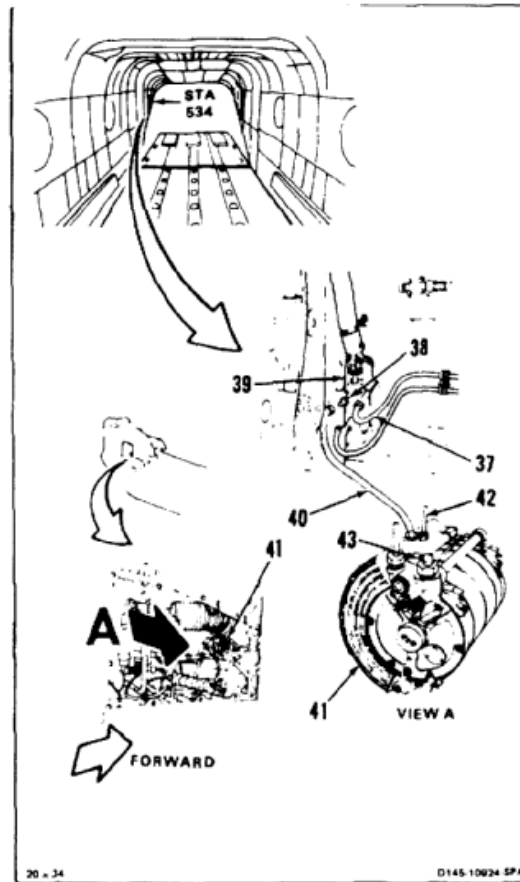

7-321 FLUSH GROUND TEST, PUMP, HAND PUMP, AND RESERVOIR PRESSURE TUBING (Continued)

7-321

- 40. Disconnect hose (36) from tubes (33 and 34).
- 41. Connect tubes (33 and 34) to valve (35).
- 42. Disconnect hose (32) from tube (31) and fitting (29).
- 43. Connect tube (31) to valve (30).
- 44. Connect fitting (29) to valve (30).

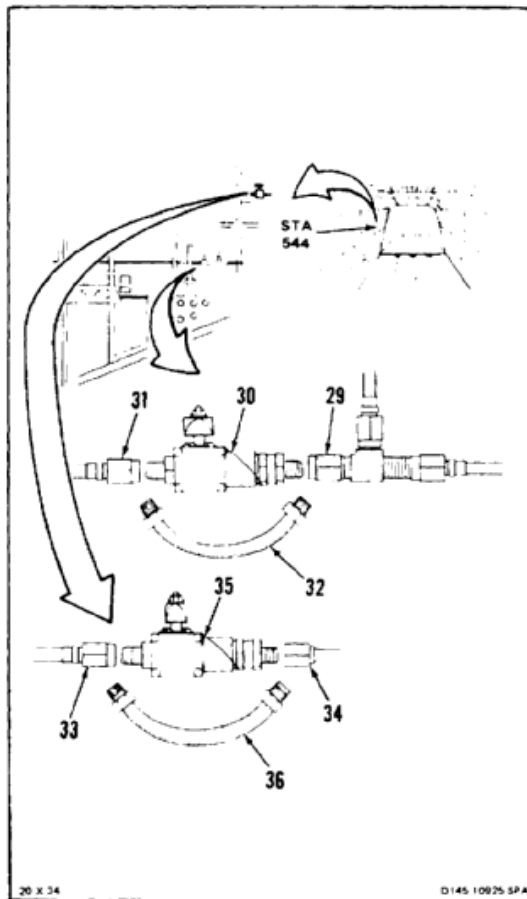

45. Remove plug (28) from tee (26).
46. Remove plug (26) from tee (25).
47. Position accumulator mount (24) on tees (25 and 26). PRESS port (50) down.
48. Install four bolts (22) and washer (23) in mount (24).

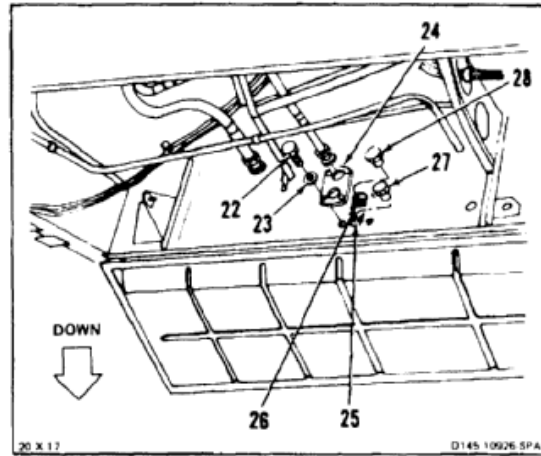

49. Disconnect hose (21) from tubes (13 and 19).
50. Connect tube (19) to PRESS port (20) of module.

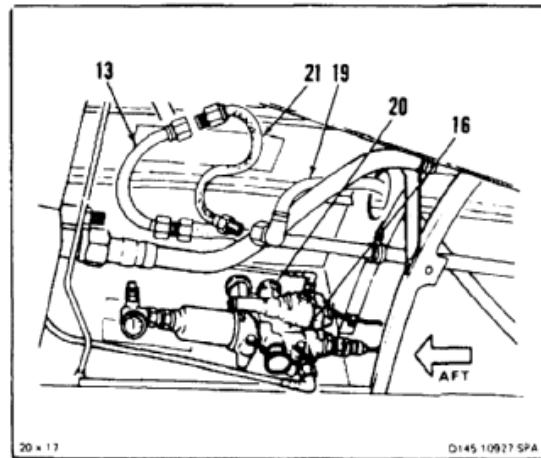

51. Disconnect tube (13) from tube (17).
52. Connect end (18) of tube (13) to ACCUM port (15) of module (16).
53. Connect tube (13) to tee (14). Remove tag from tube.
54. Connect tube (17) to tee (14).

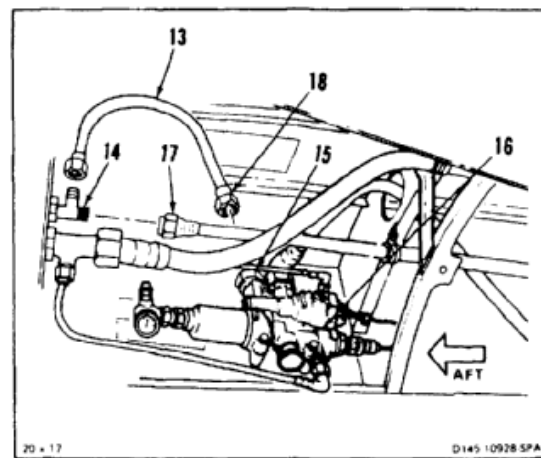

7-321 FLUSH GROUND TEST, PUMP, HAND PUMP, AND RESERVOIR PRESSURE TUBING (Continued)

7-321

55. Remove cap (12) from fitting (11).
56. Connect UTIL PUMP PRESS hose (10) to fitting (11) at sta. 540. Remove tag.

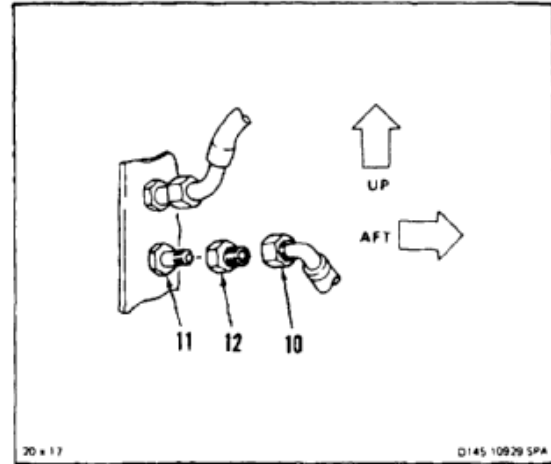

57. Disconnect hose (9) from tube (7). Use container and cloths (E104) for spilled fluid.
58. Connect tube (7) to RSVR PRESS port (8) of module (3).
59. Disconnect hose (6) from tubes (1 and 4). Remove hose.
60. Connect tube (4) to PRESS IN port (5) of module (3).
61. Connect tube (1) to EXT POWER port (2) of module (3).

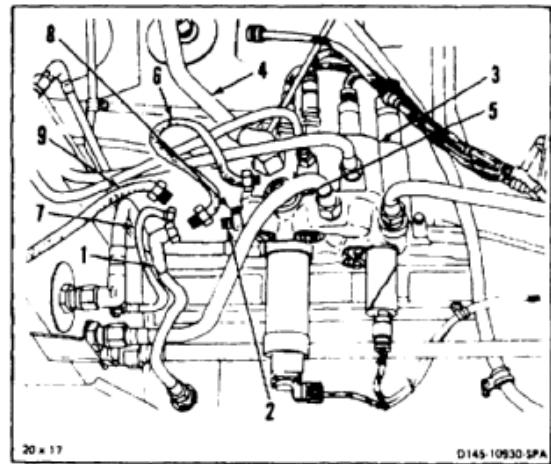
**INSPECT****FOLLOW-ON MAINTENANCE:**

- Install APU start accumulator (Task 7-149).
- Perform operational check of utility hydraulic system (TM 55-1520-240-T).
- Close ramp (TM 55-1520-240-T).

END OF TASK

INITIAL SETUP

Applicable Configurations:

All

Tools:

- Hydraulic Repairer's Tool Kit, NSN 5180-00-323-4891
- Hydraulic Test Stand
- Filter Assembly Kit ADHT6814-M9716M
- Hoses
- Container, 2 Quart
- Workstand

Materials:

- Cloths (E120)
- Gloves (E186)

Personnel Required:

- Aircraft Pneudraulics Repairer (2)
- Inspector

Equipment Condition:

- Battery Disconnected (Task 1-39)
- Electrical Power Off
- Hydraulic Power Off

- Utility Hydraulic System Depressurized (Task 7-135.1)
- Right and Left Aft Landing Gear Access Panels Open (Task 2-2)
- Ramp Open and Level (TM 55-1520-240-T)
- Forward Left Work Platform Open (Task 2-2)

General Safety Instructions:

WARNING

Hydraulic fluid (E199) is toxic. It can irritate skin and cause burns. Avoid inhaling. Use only with adequate ventilation. Avoid contact with skin, eyes, or clothing. In case of contact, immediately flush skin or eyes with water for at least **15 minutes**. Get medical attention for eyes.

WARNING

Hydraulic fluid ejected under pressure can cause injury to personnel. Hydraulic fluid sprayed into the air is a fire hazard.

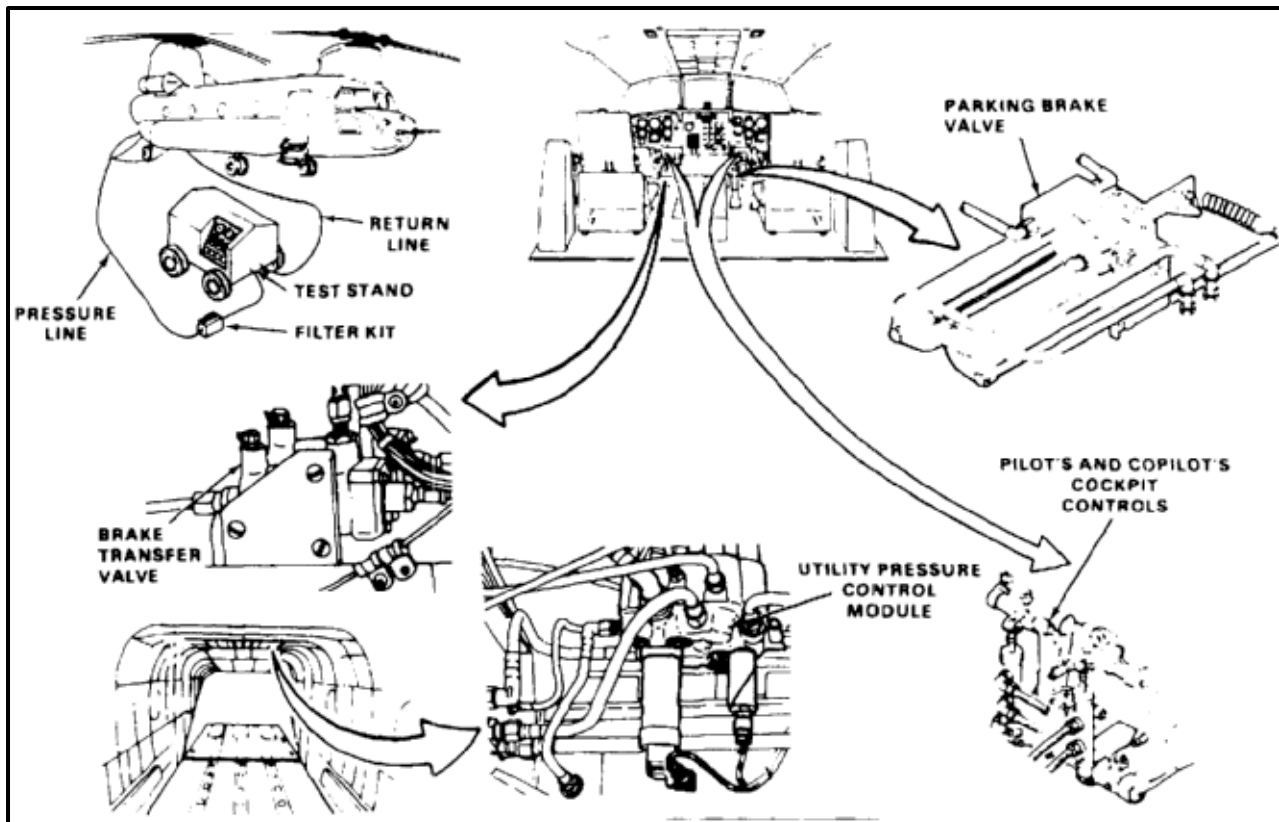

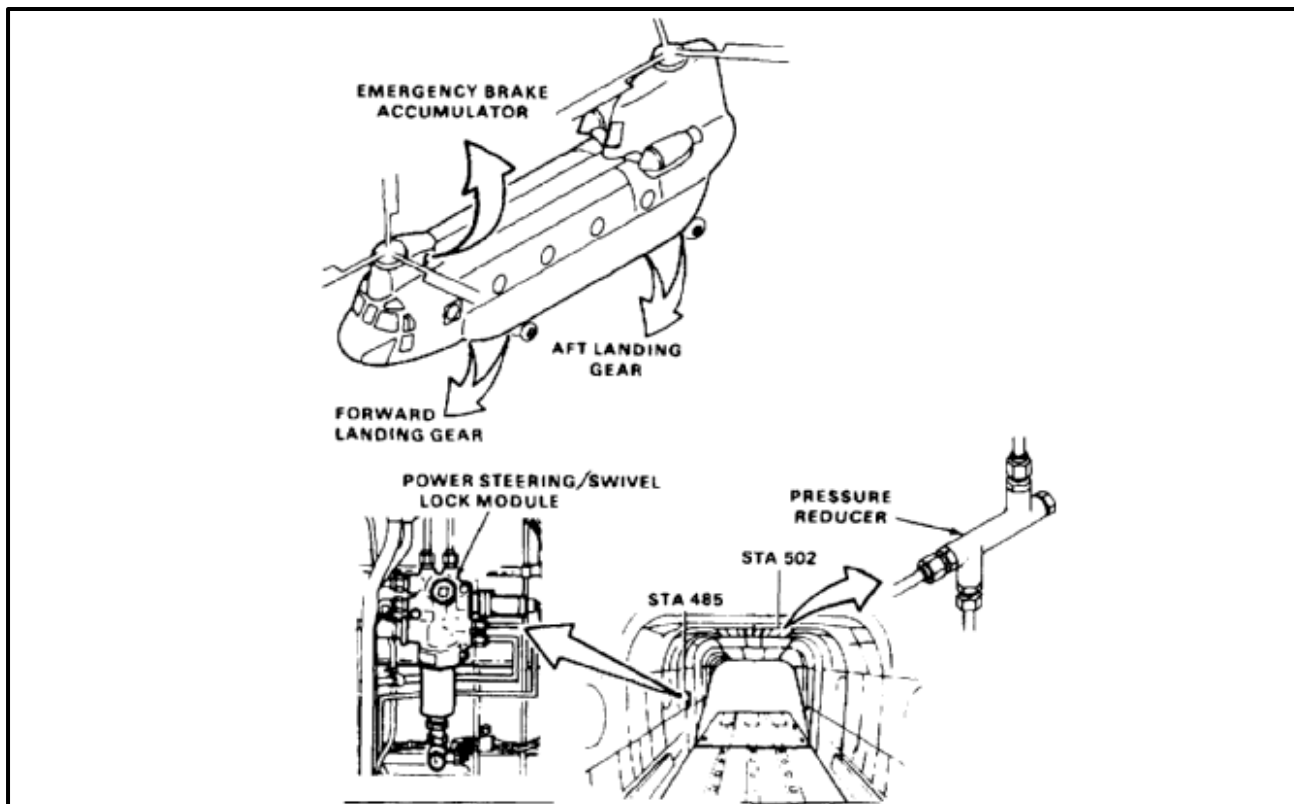

CAUTION

Filter assembly kit ADHT6814-M9716M must be installed in test stand pressure line. Otherwise, system can be contaminated.

NOTE

To operate hydraulic test stand, refer to applicable manual.

1. Working from ramp, disconnect tube (1) from BK STRG PRESS port (2) of pressure control module (3).
2. Connect test stand pressure hose (4) to tube (1).
3. Disconnect tube (5) from IN port (6) of pressure reducer (7).
4. Disconnect tube (8) from OUT port (9) of reducer (7).
5. Connect hose (10) to tube (5) and tube (8).
6. Disconnect tube (11) from IN PRESS port (12) of power steering/swivel lock module (13).
7. Install plug (14) in tube (11).

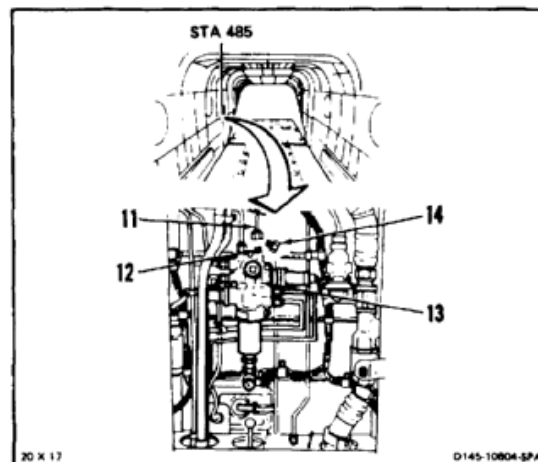
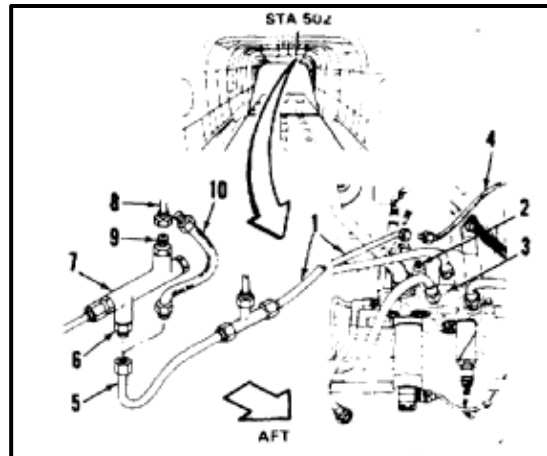

8. Working from forward left work platform, disconnect two tubes (15 and 16) from tee (17) of wheel brake accumulator (18).
9. Disconnect tee (17) from accumulator (18).
10. Connect two tubes (15 and 16) to tee (17).
11. Install plug (19) in tee (17).

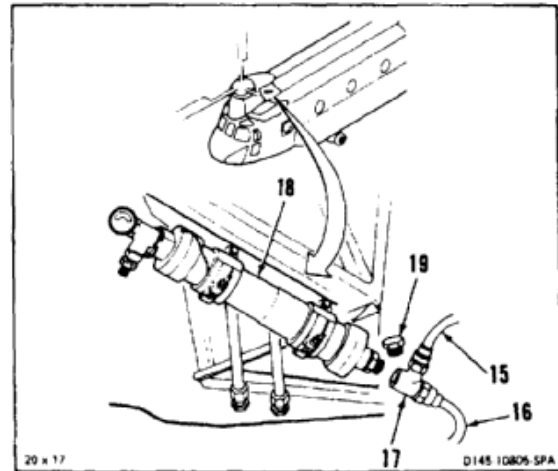

12. Working in cockpit, tag and disconnect BRAKE hose (20) from port (21) of pilot's outboard brake cylinder (22).
13. Tag and disconnect PRESS hose (23) from port (24) of cylinder (22).
14. Connect hose (20) to hose (23).
15. Repeat steps 12, 13, and 14 for pilot's inboard cylinder (25), and copilot's inboard and outboard cylinders (26 and 27).

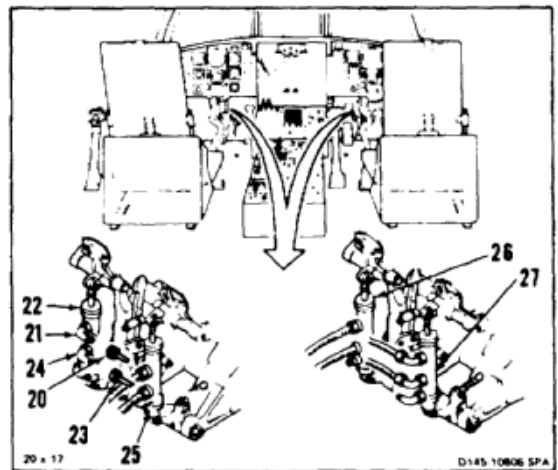

16. Working left of console, disconnect three tubes (28, 29, and 30) from outboard brake transfer valve (31).
17. Connect hose (32) to tube (28) and tee (33).
18. Connect hose (34) to tube (29) and tee (33).
19. Connect hose (35) to tube (30) and tee (33).
20. Repeat steps 16 thru 19 for inboard brake transfer valve (36).

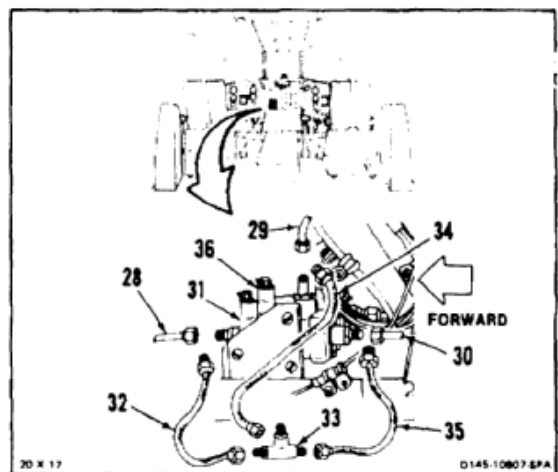

21. Working right of console, disconnect two tubes (37 and 38) from parking brake valve (39).
22. Connect hose (40) to two tubes (37 and 38).
23. Disconnect two tubes (41 and 42) from valve (39).
24. Connect hose (43) to two tubes (41 and 42).

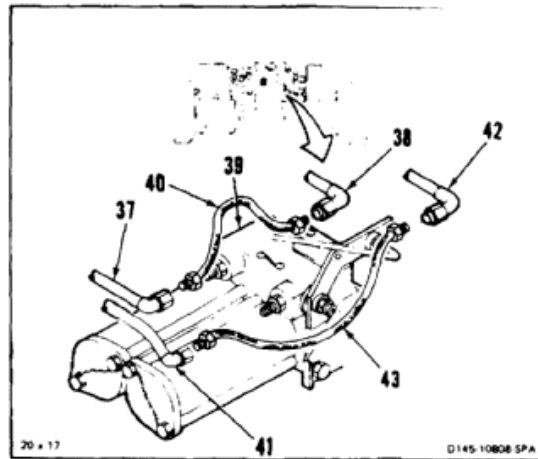

25. Working at forward left landing gear, disconnect hose (44) from brake port (45).
26. Connect hose (46) to hose (44).
27. Working at forward right landing gear disconnect hose (47) from brake port (48).
28. Connect hose (46) to hose (47).

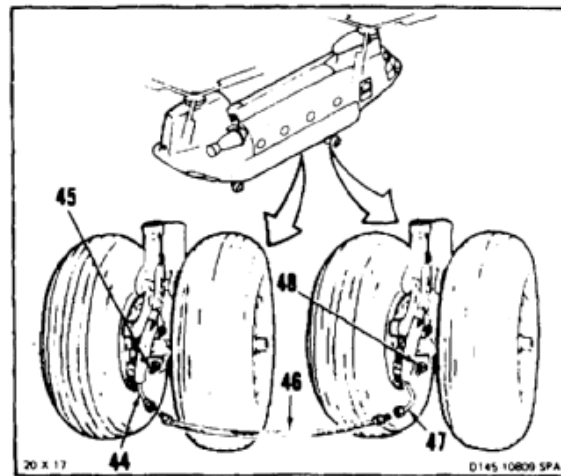

29. Working at left aft landing gear, disconnect brake hose (49) from port (50).
30. Connect hose (51) to hose (49) and tee (52).
31. Working at right aft landing gear, disconnect brake hose (53) from port (54).
32. Connect hose (55) to tee (52).
33. Connect test stand return hose (56) to tee (52).



Do not exceed **500 psi**. Otherwise damage to components can occur.



Keep test stand bypass valve closed. Otherwise, contaminants could re-enter the system.

34. Apply hydraulic power. Set stand to **10 gpm at 500 psi**. Flush system for **15 minutes**. Check for leaks.
35. Remove hydraulic power.
36. Disconnect hose (56) from tee (52). Use container and cloths (E120) for spilled fluid.
37. Disconnect hose (54) from hose (53).
38. Disconnect hose (51) from hose (49).
39. Working at forward landing gear, disconnect hose (46) from hose (44).
40. Disconnect hose (46) from hose (47).
41. Connect hose (55) to hose (44).
42. Connect hose (51) to hose (47).
43. Connect test stand return hose (56) to tee (52).

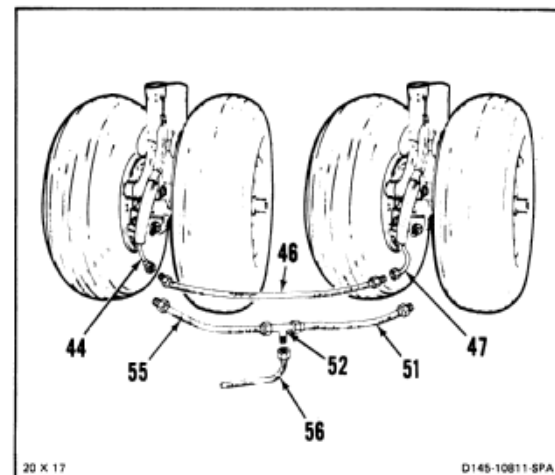
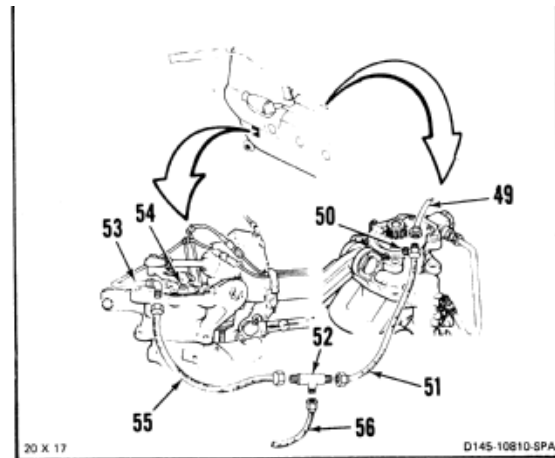

44. Working at aft landing gear, connect hose (46) to hose (53).
45. Connect hose (46) to hose (49).



Do not exceed **500 psi**. Otherwise damage to components can occur.



Keep test stand bypass valve closed. Otherwise, contaminants could re-enter the system.

46. Apply hydraulic power. Set stand to **10 gpm at 500 psi**. Flush system for **15 minutes**. Check for leaks.
47. Remove hydraulic power.
48. Disconnect hose (46) from hose (53) and hose (49). Use container and cloths (E120) for spilled fluid. Use gloves (E186).
49. Connect hose (53) to port (54).
50. Connect hose (49) to port (50).

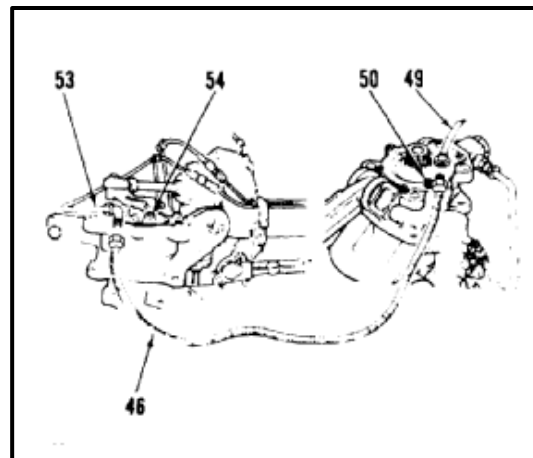

51. Working at forward landing gear, disconnect hose (56) from tee (52). Use container and cloths (E120) for spilled fluid.
52. Disconnect hoses (51 and 55) from tee (52). Remove tee.
53. Disconnect hose (55) from hose (44).
54. Connect hose (44) to port (45).
55. Disconnect hose (51) from hose (47).
56. Connect hose (47) to port (48).

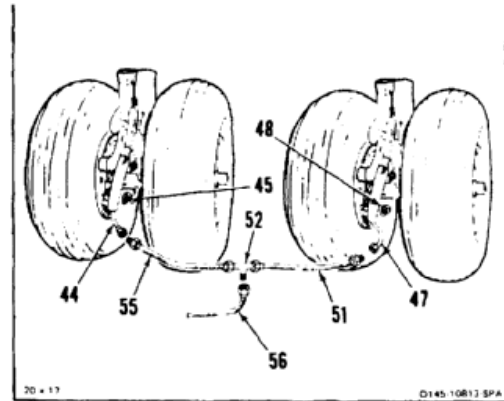

57. Working in cockpit, right of console, disconnect hose (43) from two tubes (41 and 42). Use cloths (E120) for spilled fluid. Use gloves (E186).
58. Connect tube (41) to port (57) of valve (39).
59. Connect tube (42) to port (58) of valve (39).
60. Disconnect hose (40) from two tubes (37 and 38). Use cloths (E120) for spilled fluid.
61. Connect tube (37) to port (59) of valve (39).
62. Connect tube (38) to port (60) of valve (39).

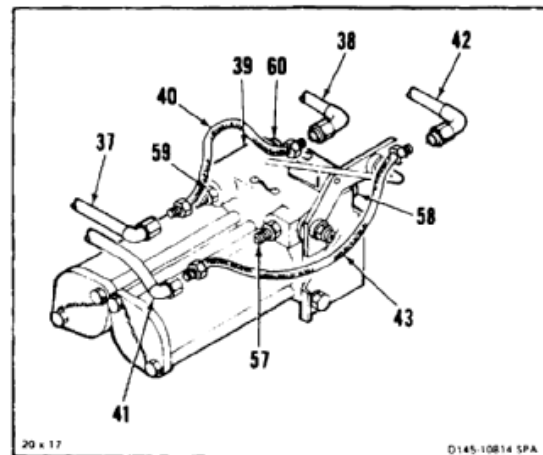

63. Working left of console, disconnect three hoses (32, 34, and 35) from tee (33). Remove tee. Use cloths (E120) for spilled fluid.
64. Disconnect hose (32) from tube (28).
65. Connect tube (28) to port (61) of valve (31).
66. Disconnect hose (34) from tube (29).
67. Connect tube (29) to port (62) of valve (31).
68. Disconnect hose (35) from tube (30).
69. Connect tube (30) to port (63) of valve (31).
70. Repeat steps 63 thru 69 for inboard valve (36).

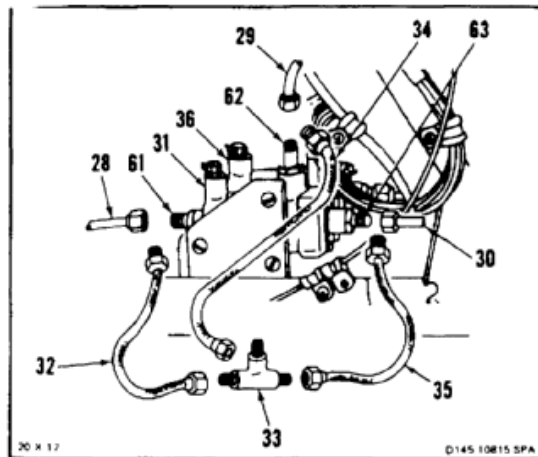

71. Working at pilot's outboard cylinder (22), disconnect hose (20) from hose (23).
72. Connect hose (20) to BRAKE port (21) of cylinder (22). Remove tag.
73. Connect hose (23) to PRESS port (24) of cylinder (22). Remove tag.
74. Repeat steps 71, 72, and 73 for pilot's inboard cylinder (25), and copilot's inboard and outboard cylinders (26 and 27).

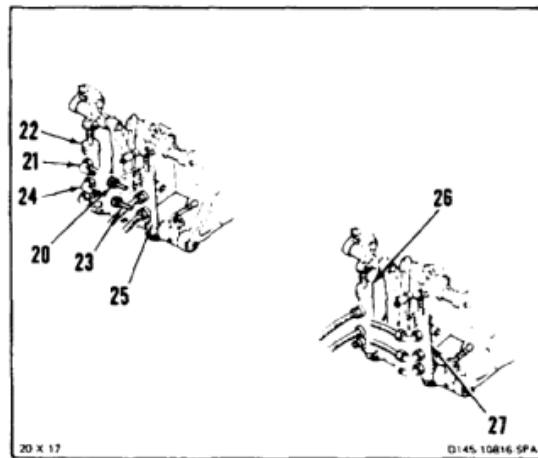

75. Working from forward left work platform, remove plug (19) from tee (17).
76. Disconnect two tubes (15 and 16) from tee (17).
77. Connect tee (17) to accumulator (18).
78. Connect two tubes (15 and 16) to tee (17).

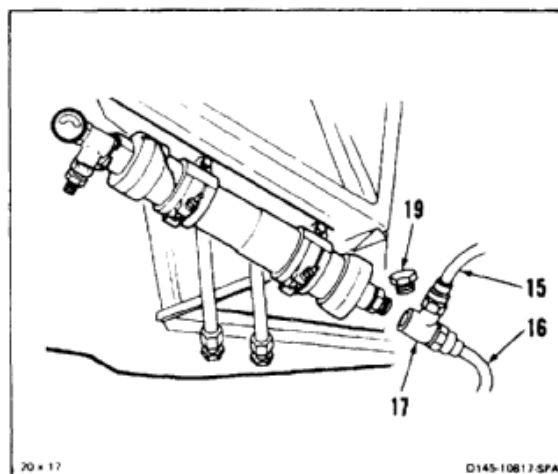

79. Working from ramp, remove plug (12) from tube (11) of module (13).
80. Connect tube (11) to IN PRESS port (12) of module (13).

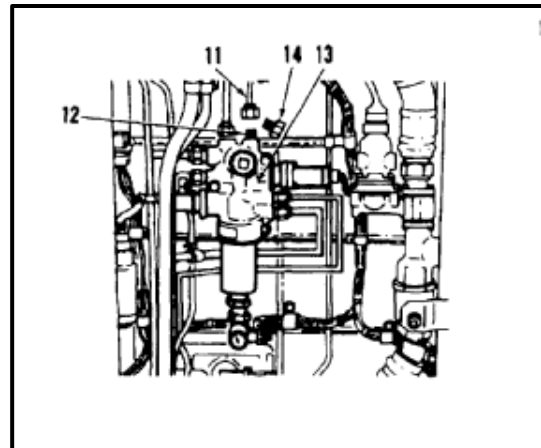

81. Disconnect hose (10) from two tubes (5 and 8) of reducer (7).
82. Connect tube (5) to IN port (6) of reducer (7).
83. Connect tube (8) to OUT port (9) of reducer (7).
84. Connect hose (4) from tube (1) of module (3). Use container and cloths (E120) for spilled fluid.
85. Connect tube (1) to BK STRG PRESS port (2) of module (3).

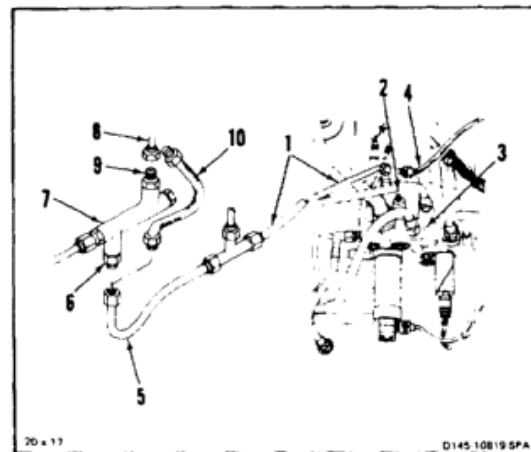
**INSPECT****FOLLOW-ON MAINTENANCE:**

- Perform operational test of utility hydraulic system (TM 55-1520-240-T).
- Close forward left work platform (Task 2-2).
- Close right and left aft landing gear access panels (Task 2-2).
- Close ramp (TM 55-1520-240-T).

END OF TASK

INITIAL SETUP

Applicable Configurations:

All

Tools:

- Hydraulic Repairer's Tool Kit, NSN 5180-00-323-4891
- Hydraulic Test Stand
- Filter Assembly Kit ADHT6814-M9716M
- Hoses
- Container, 2 Quart

Materials:

- Cloths (E120)
- Paper Tags (E264)
- Gloves (E186)

Personnel Required:

- Aircraft Pneudraulics Repairer (2)
- Inspector

Equipment Condition:

- Battery Disconnected (Task 1-39)
- Electrical Power Off
- Hydraulic Power Off
- Utility Hydraulic System Depressurized (Task 7-135.1)

- Power Steering Swivel/Lock Module Removed (Task 7-291)
- Left and Right Aft Landing Gear Access Covers Open (Task 2-2)
- Ramp Open and Level (TM 55-1520-240-T)

General Safety Instructions:

WARNING

Hydraulic fluid (E199) is toxic. It can irritate skin and cause burns. Avoid inhaling. Use only with adequate ventilation. Avoid contact with skin, eyes, or clothing. In case of contact, immediately flush skin or eyes with water for at least **15 minutes**. Get medical attention for eyes.

WARNING

Hydraulic fluid ejected under pressure can cause injury to personnel. Hydraulic fluid sprayed into the air is a fire hazard.

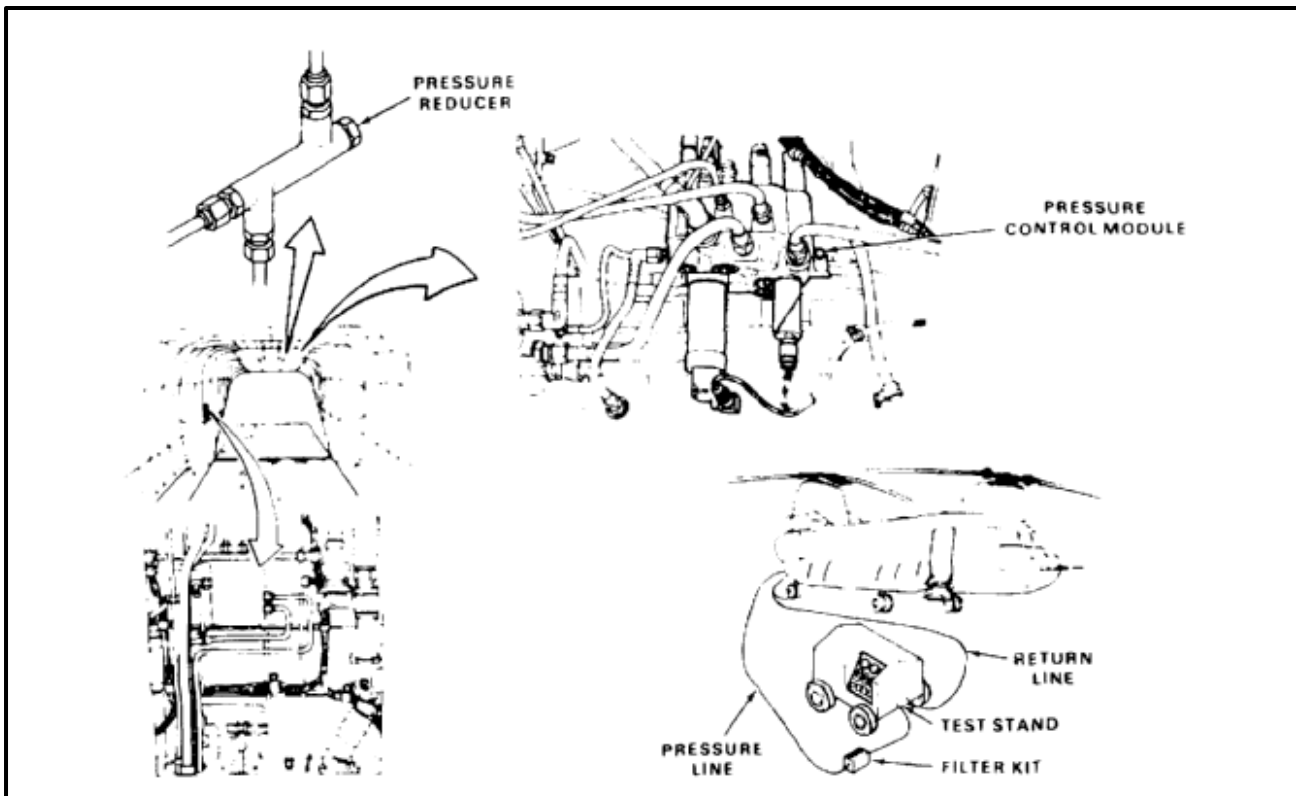

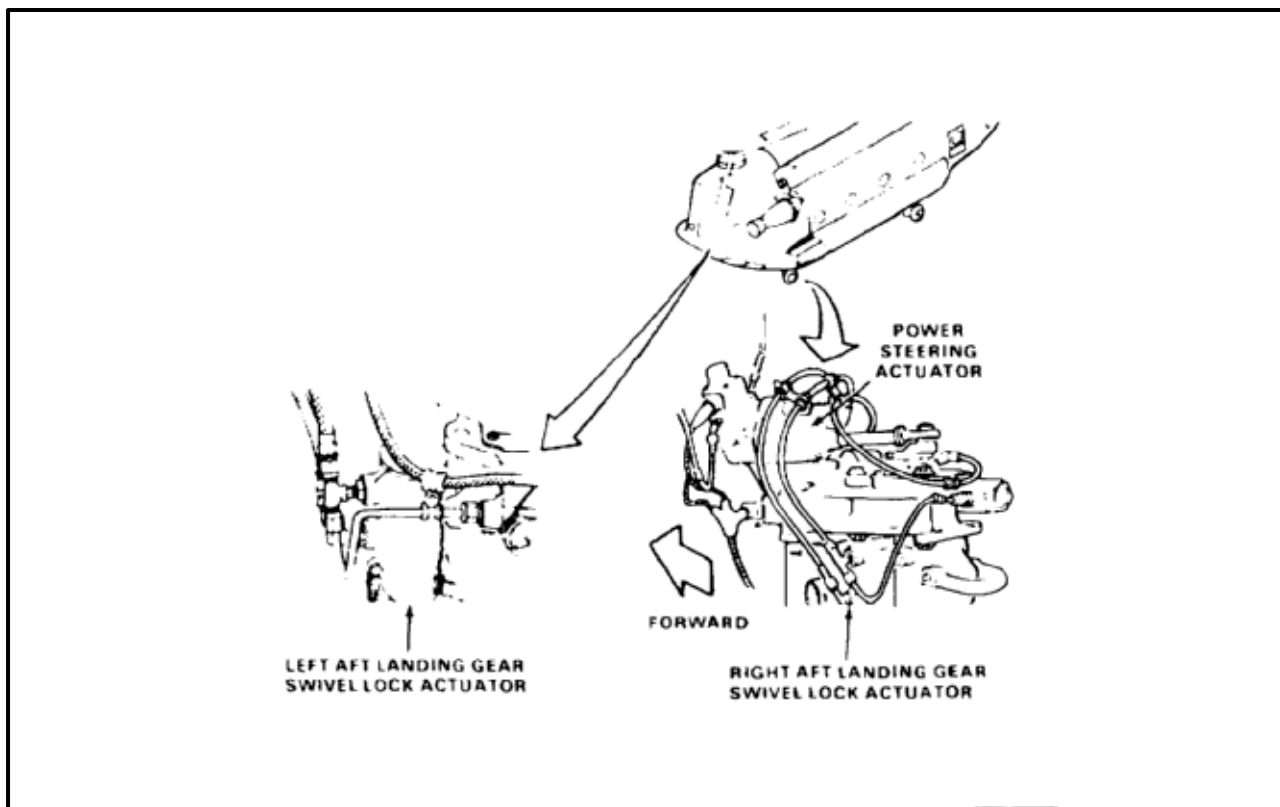

CAUTION

Filter assembly kit ADHT6814-M9716M must be installed in test stand pressure line. Otherwise, system can be contaminated.

NOTE

To operate hydraulic test stand, refer to applicable manual.

1. Working from ramp, disconnect tube (1) from BK STRG PRESS port (2) of pressure control module (3).
2. Connect test stand pressure hose (4) to tube (1).

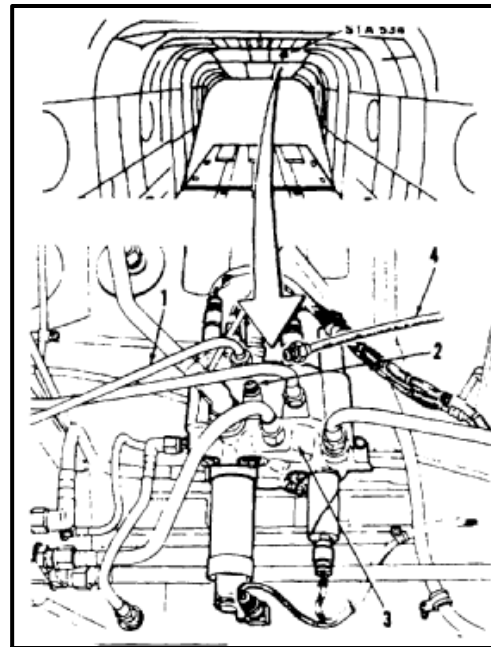

3. Connect hose (5) to IN PRESS tube (6).
4. Connect hose (5) to SWVL UNLOCK tube (7).
5. Connect hose (8) to PWR STRG PRESS tube (9).
6. Connect hose (8) to SWVL LOCK tube (10).
7. Connect test stand return hose (11) to PWR STRG RTN tube (12).
8. Disconnect tube (13) from INLET port (14) of pressure reducer (15).
9. Install plug (16) in tube (13).

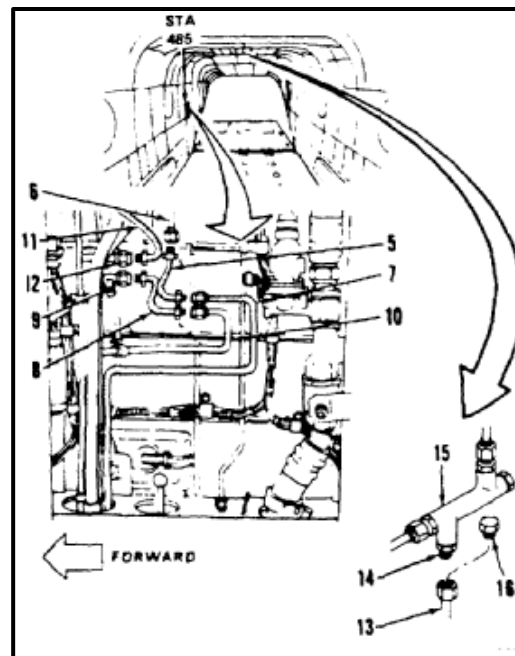

10. Working at right aft landing gear, tag and disconnect PWR STRG RTN hose (17) from elbow (18) on fuselage.
11. Tag and disconnect PWR STRG PRESS hose (19) from port (20) of power steering actuator (21).
12. Connect hose (19) to elbow (18).
13. Disconnect SWIVEL UNLOCK hose (22) from swivel actuator (23).
14. Disconnect SWIVEL LOCK hose (24) from actuator (23).
15. Connect two hoses (22 and 24) to union (25).
16. Repeat steps 13, 14, and 15 at left landing gear.



Do not exceed **500 psi**. Otherwise damage to components can occur.



Keep test stand bypass valve closed. Otherwise, contaminants could re-enter the system.

17. Apply hydraulic power. Set stand to **10 gpm at 500 psi**. Flush system for **15 minutes**. Check for leaks.
18. Remove hydraulic power.
19. Working from ramp, disconnect hose (11) from tube (12). Use container and cloths (E120) for spilled fluid. Use gloves (E186).
20. Install plug (26) in tube (12).

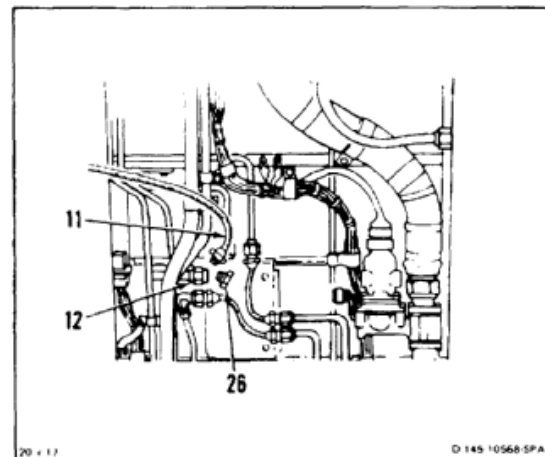
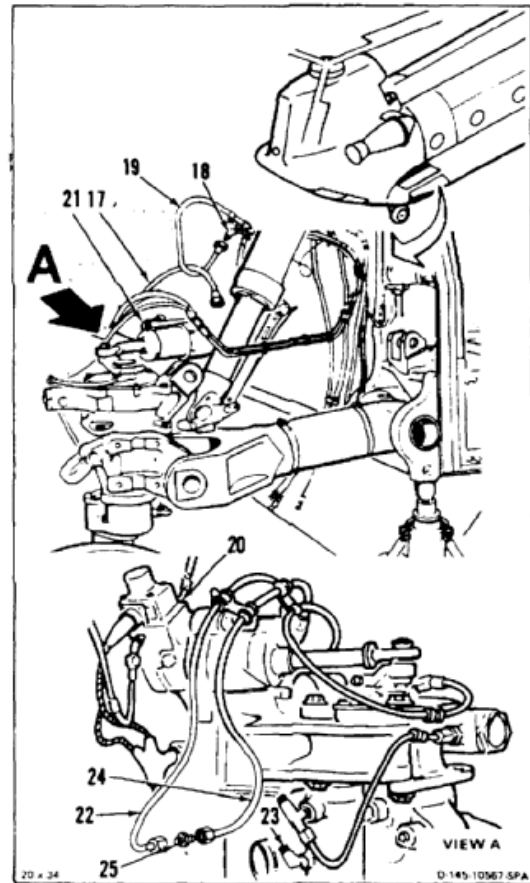

21. Working at left aft landing gear, disconnect two hoses (27 and 28) from union (29). Remove union. Use container and cloths (E120) for spilled fluid. Use gloves (E186).
22. Connect two hoses (27 and 28) to tee (30).
23. Connect hose (11) to tee (30).



Do not exceed **500 psi**. Otherwise damage to components can occur.



Keep test stand bypass valve closed. Otherwise, contaminants could re-enter the system.

24. Apply hydraulic power. Set stand to **10 gpm at 500 psi**. Flush system for **15 minutes**. Check for leaks.
25. Remove hydraulic power.
26. Disconnect hose (11) from tee (30). Use container and cloths (E120) for spilled fluid. Use gloves (E186).
27. Install cap (31) on tee (30).
28. Working at right aft landing gear, disconnect two hoses (22 and 24) from union (25). Remove union. Use container and cloths (E120) for spilled fluid. Use gloves (E186).
29. Connect two hoses (22 and 24) to tee (31).



Do not exceed **500 psi**. Otherwise damage to components can occur.



Keep test stand bypass valve closed. Otherwise, contaminants could re-enter the system.

30. Apply hydraulic power. Set stand to **10 gpm at 500 psi**. Flush system for **15 minutes**. Check for leaks.

31. Remove hydraulic power.
32. Remove hose (11) from tee (31). Use container and cloths (E120) for spilled fluid.
33. Disconnect two hoses (22 and 24) from tee (31). Remove tee.
34. Connect SWIVEL UNLOCK hose (22) to lower tee (32) of actuator (23).
35. Connect SWIVEL LOCK hose (24) to upper tee (33) of actuator (23).

INSPECT

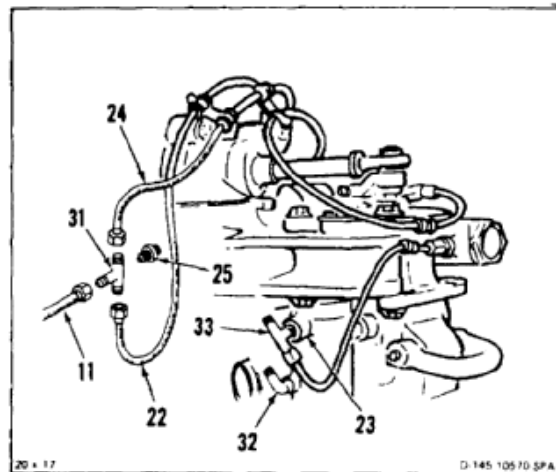
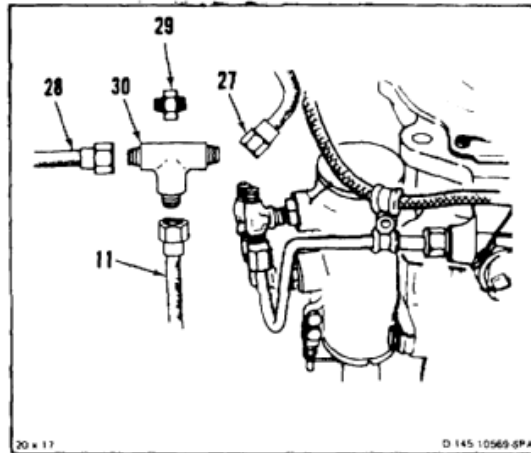

36. Working at left aft landing gear, disconnect two hoses (27 and 28) from tee (30). Remove tee. Use container and cloths (E120) for spilled fluid.
37. Connect SWIVEL UNLOCK hose (28) to lower elbow (34) of actuator (35).
38. Connect SWIVEL LOCK hose (27) to upper tee (36) of actuator (35).

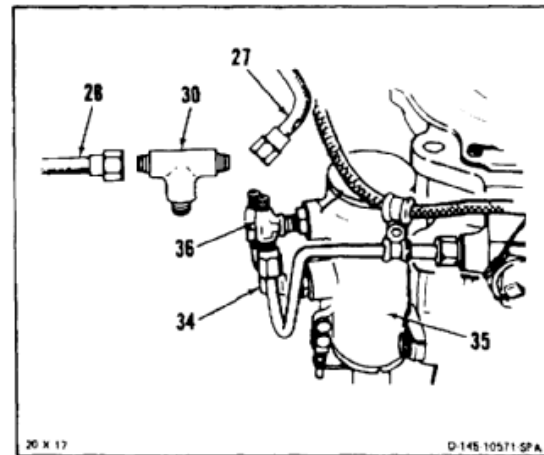
INSPECT

39. Working at right aft landing gear, disconnect hose (19) from elbow (18) on fuselage.
40. Connect PWR STRG RTN hose (17) to elbow (18). Remove tag.
41. Connect PWR STRG PRESS hose (19) to port (20) of actuator (21). Remove tag.

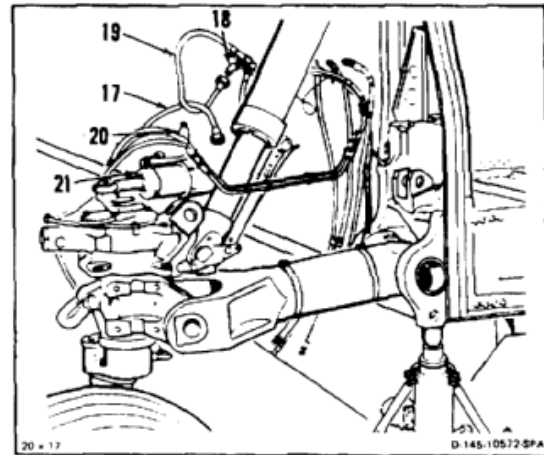
INSPECT

42. Working from ramp, disconnect hose (11) from tube (12). Use container and cloths (E120) for spilled fluid. Use gloves (E186).
43. Disconnect hose (8) from tubes (9 and 10). Use cloths (E120) for spilled fluid.
44. Disconnect hose (5) from tubes (6 and 7). Use cloths for spilled fluid.
45. Remove plug (16) from tube (13).
46. Connect tube (13) to INLET port (14) of pressure reducer (15).

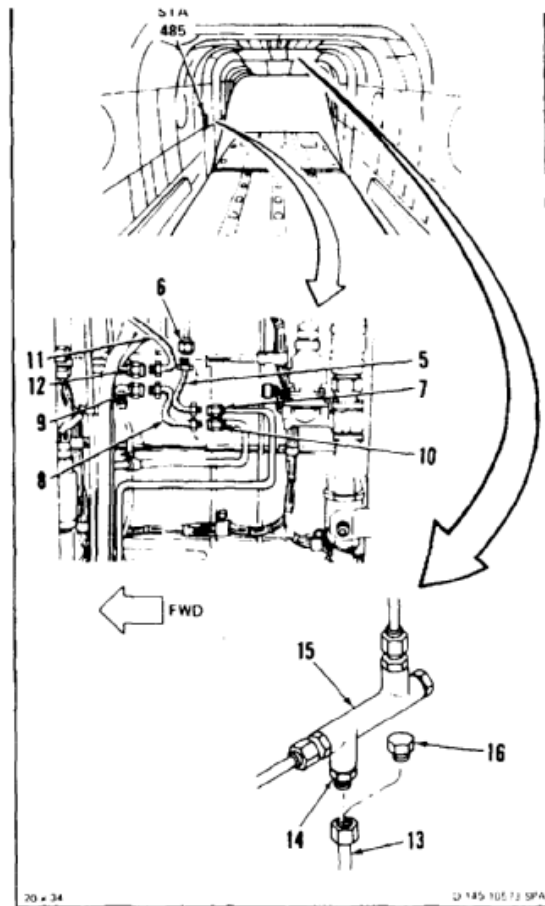

47. Disconnect hose (4) from module (3). Use container and cloths (E120) for spilled fluid.
48. Connect tube (1) to BK STRG PRESS port (2) of module (3).

INSPECT

FOLLOW-ON MAINTENANCE:

- Install power steering swivel/lock module (Task 7-292).
- Perform operational check of power steering (TM 55-1520-240-T).
- Close left and right aft landing gear access covers (Task 2-2).

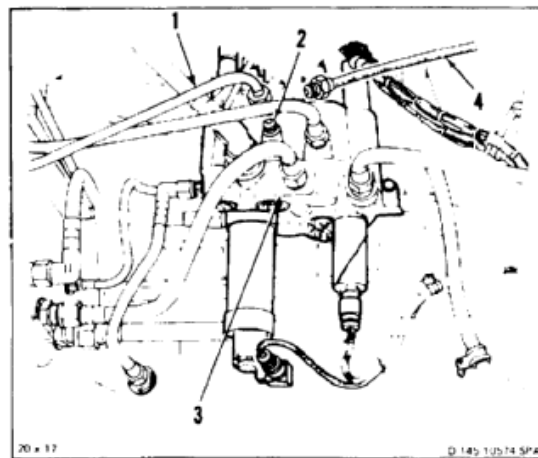

END OF TASK

INITIAL SETUP

Applicable Configurations:

All

Tools:

- Hydraulic Repairer's Tool Kit, NSN 5180-00-323-4891
- Hydraulic Test Stand
- Filter Assembly Kit ADHT6814-M9716M
- Workstand
- Hoses
- Container, 2 Quart
- Tees

Materials:

- Paper Tags (E264)
- Cloth (E120)
- Gloves (E186)

Personnel Required:

- Aircraft Pneudraulics Repairer (2)
- Inspector

Equipment Condition:

Battery Disconnected (Task 1-39)

- Electrical Power Off
- Hydraulic Power Off
- Utility Hydraulic System Depressurized (Task 7-135.1)
- Ramp Down and Level (TM 55-1520-240-T)

General Safety Instructions:

WARNING

Hydraulic fluid (E199) is toxic. It can irritate skin and cause burns. Avoid inhaling. Use only with adequate ventilation. Avoid contact with skin, eyes, or clothing. In case of contact, immediately flush skin or eyes with water for at least **15 minutes**. Get medical attention for eyes.

WARNING

Hydraulic fluid ejected under pressure can cause injury to personnel. Hydraulic fluid sprayed into the air is a fire hazard.

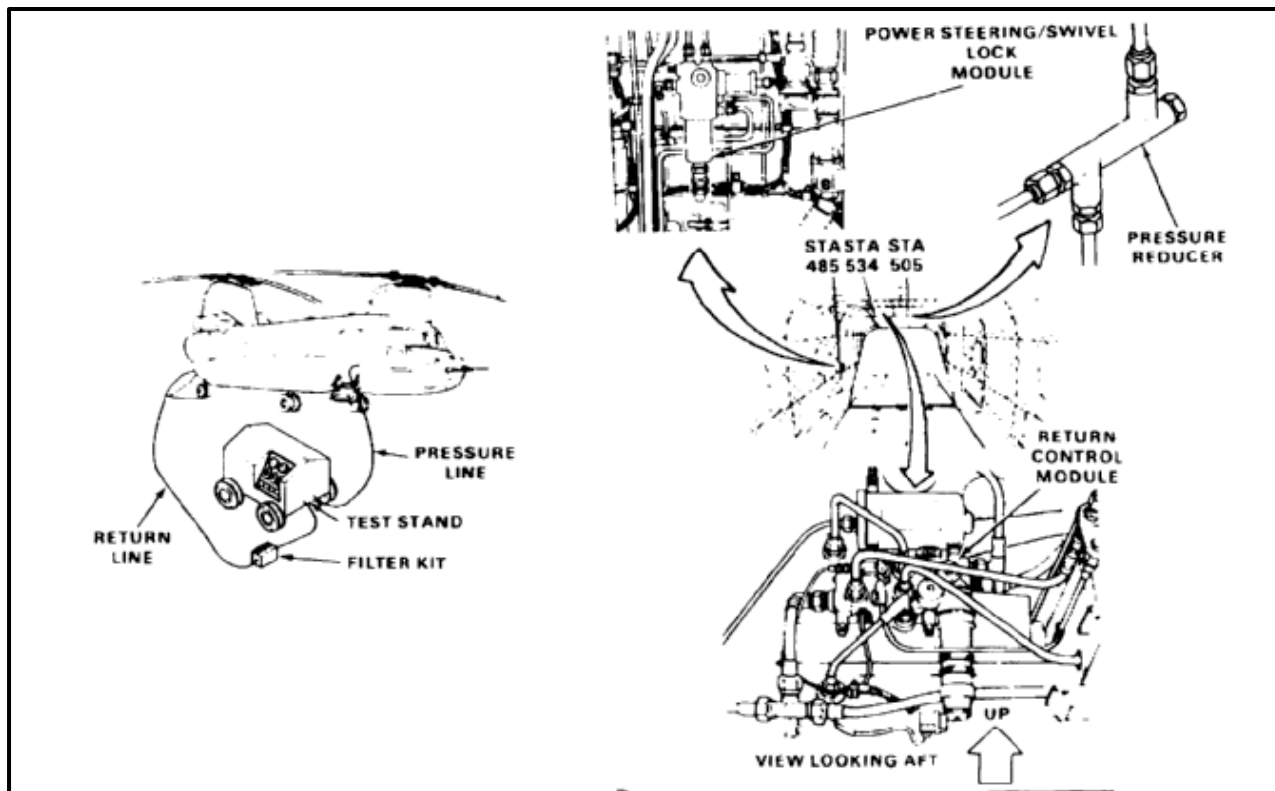

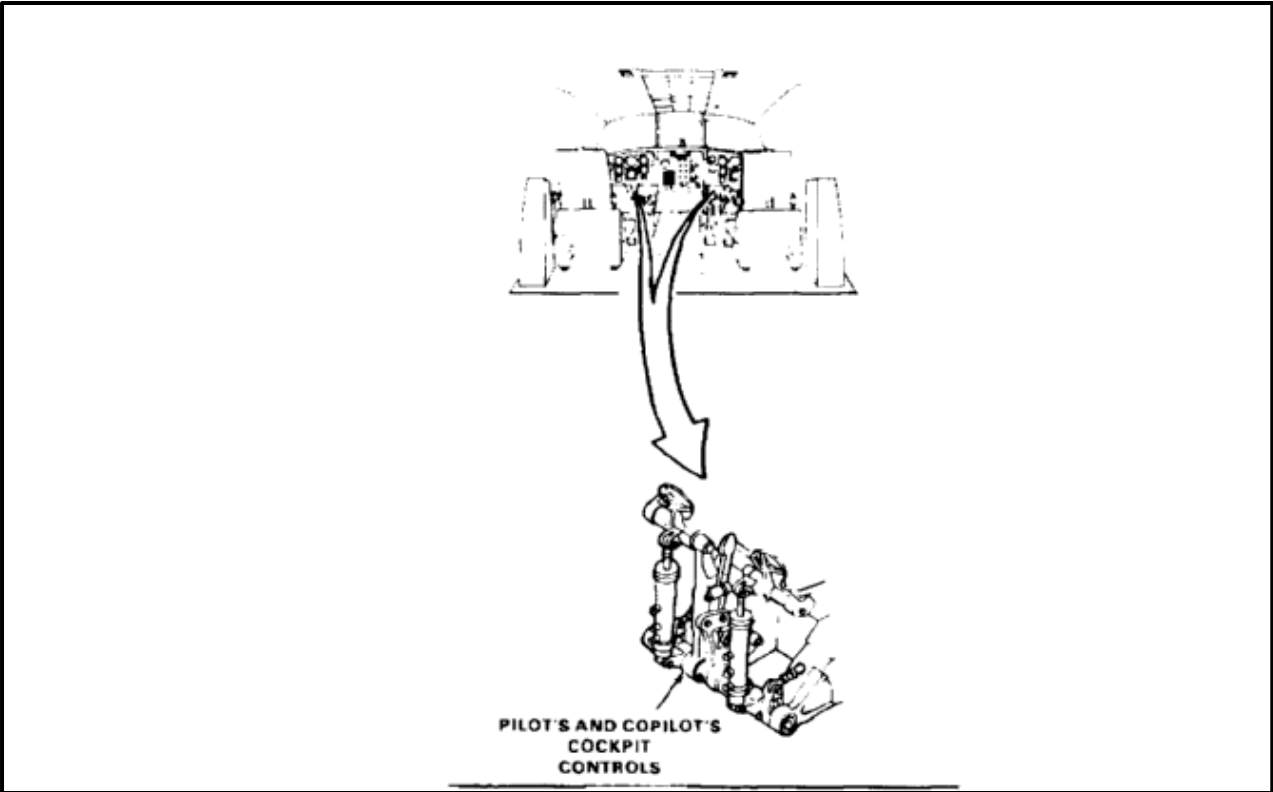

CAUTION

Filter assembly kit ADHT6814-M9716M must be installed in test stand pressure line. Otherwise, system can be contaminated.

NOTE

To operate hydraulic test stand, refer to applicable manual.

1. Working from ramp, disconnect PWR STRG RTN tube (1) from port (2) of return control module (3).
2. Connect test stand return hose (4) to tube (1).
3. Disconnect return tube (5) from pressure reducer (6).
4. Install plug (7) in tube (5).
5. Disconnect PWR STRG RTN tube (8) from power steering module (9).
6. Install plug (10) in tube (8).

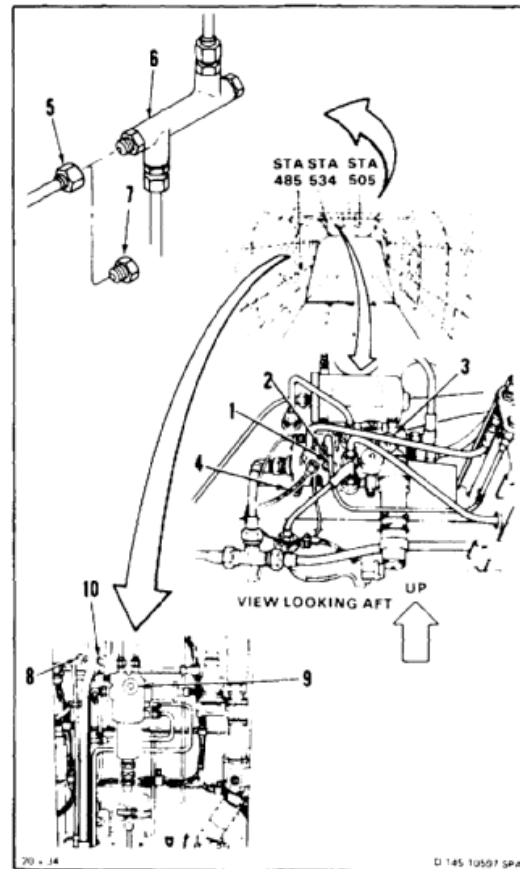

7. Working in cockpit, tag and disconnect RTN hose (11) from port (12) of pilot's brake cylinder (13).
8. Connect hose (11) to tee (14).
9. Tag and disconnect RTN hose (15) from port (16) pilot's brake cylinder (17).
10. Connect hose (15) to tee (14).
11. Tag and disconnect RTN hose (18) from port (19) of copilot's brake cylinder (20).
12. Connect hose (18) to tee (21).
13. Tag and disconnect RTN hose (22) for port (23) of copilot's brake cylinder (24).
14. Connect hose (22) to tee (21).
15. Connect hose (25) to tee (14) then to tee (26).
16. Connect hose (27) to tee (21) then to tee (26).
17. Connect test stand pressure hose (28) to tee (26).



Do not exceed **500 psi**. Otherwise damage to components can occur.



Keep test stand bypass valve closed. Otherwise, contaminants could re-enter the system.

18. Apply hydraulic power. Set stand to **10 gpm at 500 psi**. Flush system for **15 minutes**. Check for leaks.
19. Remove hydraulic power.

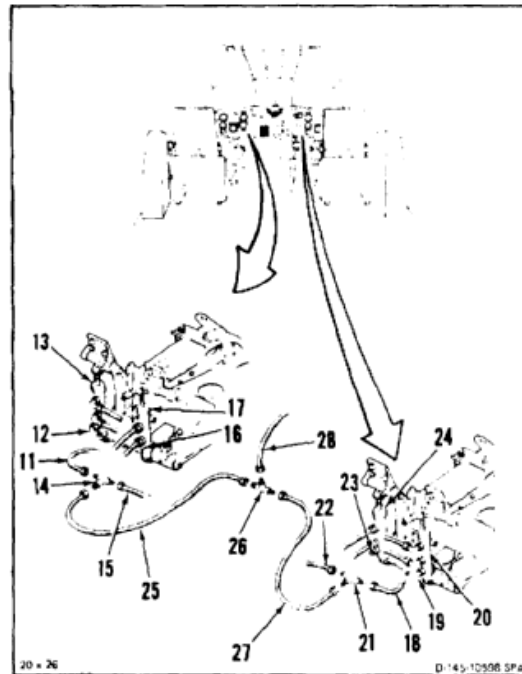

20. Working from ramp, disconnect hose (4) from tube (1). Use container and cloths (E120) for spilled fluid. Use gloves (E186).
21. Install plug (29) in tube (1).
22. Remove plug (10) from tube (8).
23. Connect hose (4) to tube (8).



Do not exceed **500 psi**. Otherwise damage to components can occur.



Keep test stand bypass valve closed. Otherwise, contaminants could re-enter the system.

24. Apply hydraulic power. Set stand to **10 gpm at 500 psi**. Flush system for **15 minutes**. Check for leaks.
25. Remove hydraulic power.
26. Disconnect hose (4) from tube (8). Use container and cloths (E120) for spilled fluid.
27. Connect tube (8) to PWR STRG RTN port (30) of module (9).
28. Remove plug (29) from tube (1).
29. Connect tube (1) to PWR STRG RTN port (2) of module (3).
30. Remove plug (7) from tube (5).
31. Connect tube (5) to RTN port (31) of reducer (6).

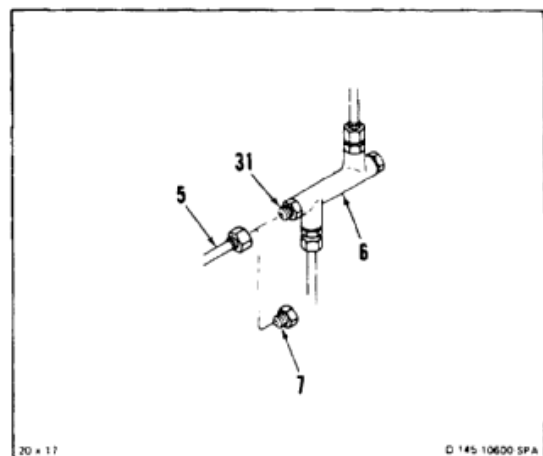
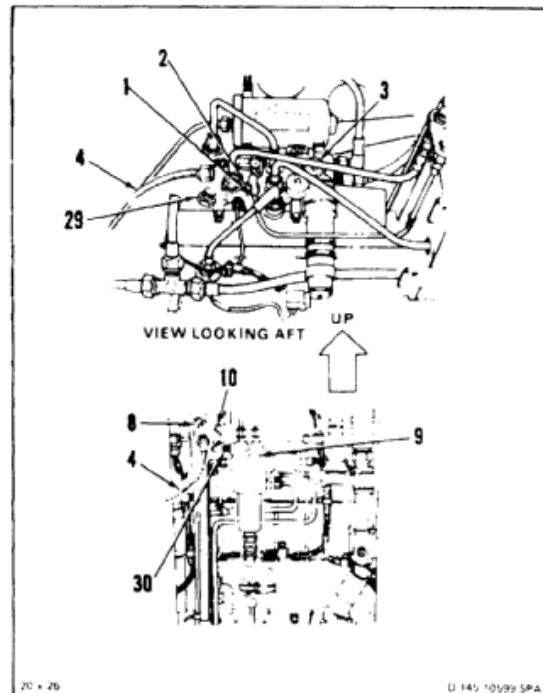

32. Working in cockpit, disconnect hose (28) from tee (26). Use container and cloths (E120) for spilled fluid.
33. Disconnect two hoses (25 and 27) from three tees (26, 21 and 14). Use container and cloths (E120) for spilled fluid.
34. Disconnect two hoses (18 and 22) from tee (21).
35. Disconnect two hoses (11 and 15) from tee (14).
36. Connect hose (11) to RTN port (12) of cylinder (13). Remove tag.
37. Connect hose (15) to RTN port (16) of cylinder (17). Remove tag.
38. Connect hose (22) to RTN port (23) of cylinder (24). Remove tag.
39. Connect hose (18) to RTN port (19) of cylinder (20). Remove tag.

INSPECT**FOLLOW-ON MAINTENANCE:**

Perform operational check of power steering system (TM 55-1520-240-T).

Perform operational check of brake system (TM 55-1520-240-T).

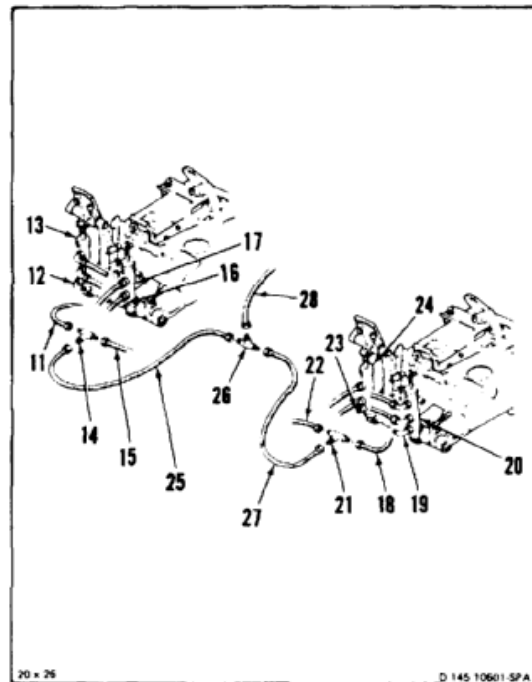

END OF TASK

7-1186

INITIAL SETUP

Applicable Configurations:

All

Tools:

- Hydraulic Repairer's Tool Kit, NSN 5180-00-323-4891
- Hydraulic Test Stand
- Filter Assembly Kit ADHT6814-M9716M
- Hoses
- Container, 2 Quart
- Workstand

Materials:

- Cloths (E120)
- Paper Tags (E264)
- Gloves (E186)

Personnel Required:

- Aircraft Pnedraulics Repairer (2)
- Inspector

Equipment Condition:

- Battery Disconnected (Task 1-39)
- Electrical Power Off

- Hydraulic Power Off
- Utility Hydraulic System Depressurized (Task 7-135.1)
- Cargo Ramp Control Valve Removed (Task 7-266)
- Cargo Ramp Down and Level (TM 55-1520-240-T)

General Safety Instructions:

WARNING

Hydraulic fluid (E199) is toxic. It can irritate skin and cause burns. Avoid inhaling. Use only with adequate ventilation. Avoid contact with skin, eyes, or clothing. In case of contact, immediately flush skin or eyes with water for at least **15 minutes**. Get medical attention for eyes.

WARNING

Hydraulic fluid ejected under pressure can cause injury to personnel. Hydraulic fluid sprayed into the air is a fire hazard.

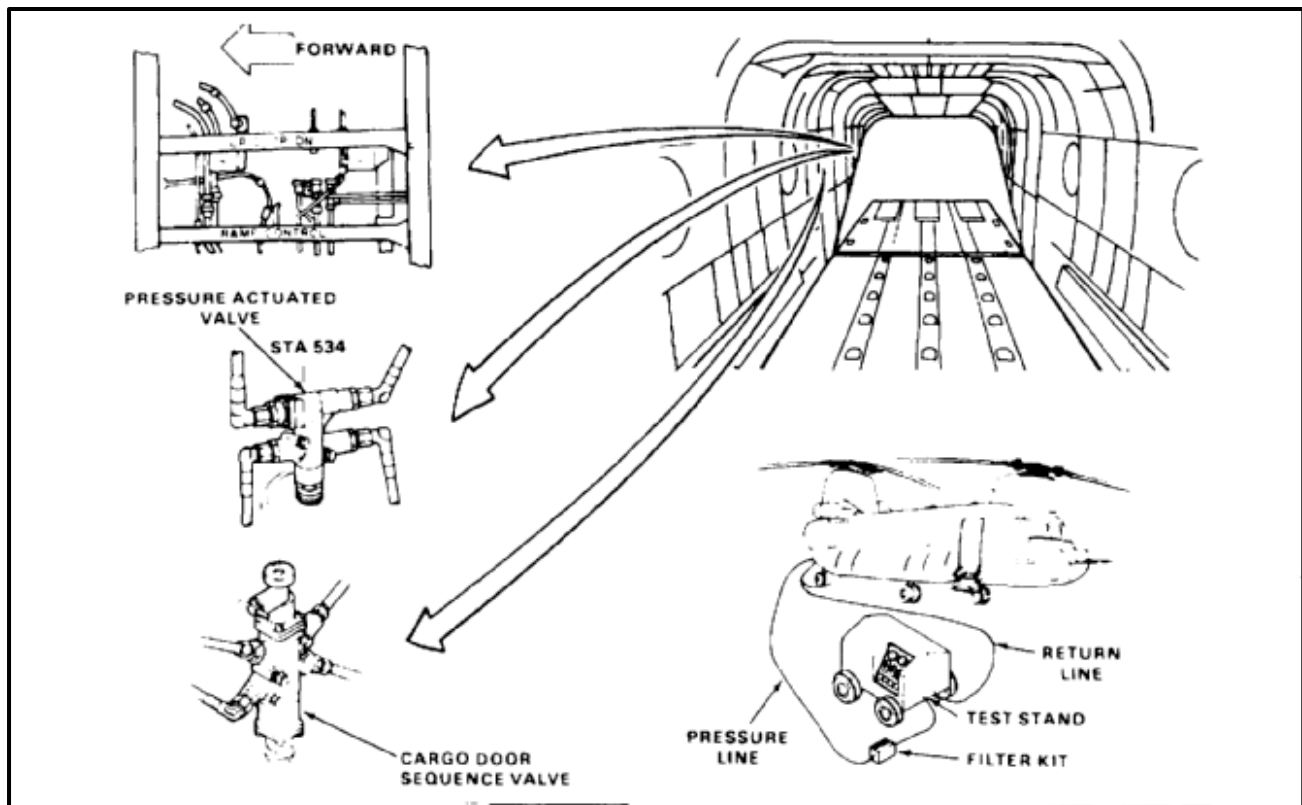

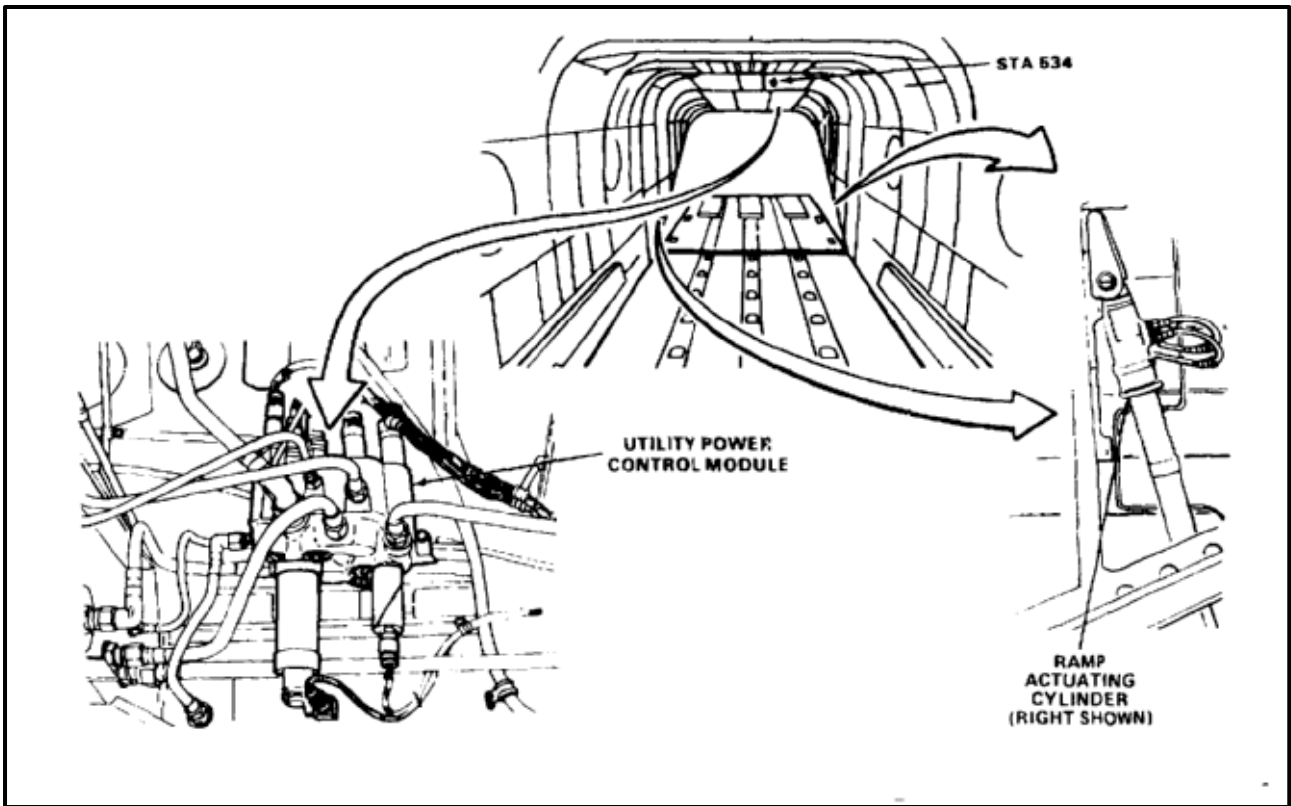

CAUTION

Filter assembly kit ADHT6814-M9716M must be installed in test stand pressure line. Otherwise, system can be contaminated.

NOTE

To operate hydraulic test stand, refer to applicable manual.

1. Working from ramp, disconnect tube (1) from RAMP pressure port (2) of pressure control module (3).
2. Connect test stand pressure hose (4) to tube (1).

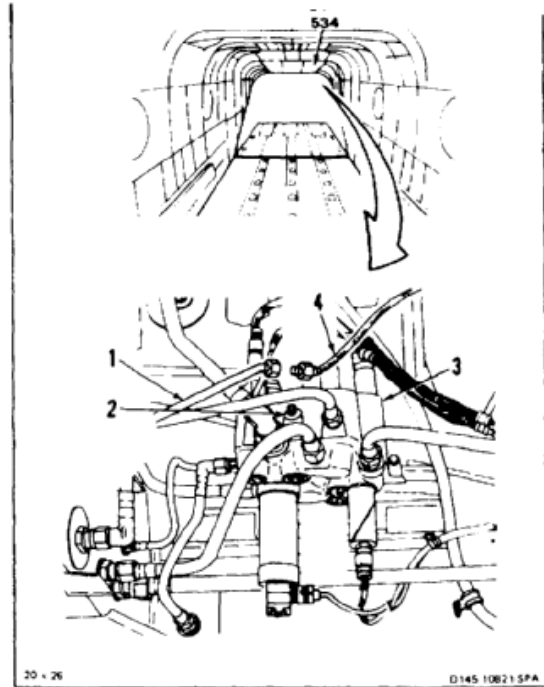

3. Connect hose (5) to pressure tubes (6 and 7).
4. Connect hose (8) to RAMP DOWN tube (9).
5. Connect hose (8) to UNLOCK tube (10).

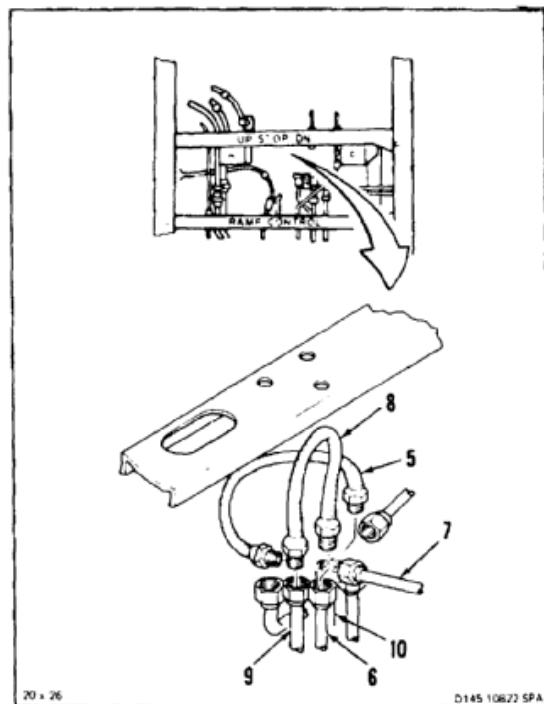

6. Disconnect tube (11) from PRESS port (12) of cargo door sequence valve (13).
7. Disconnect tube (14) from C1 port (15) of valve (13).
8. Connect hose (16) to tubes (11 and 14).
9. Disconnect tube (17) from C2 port (18) of valve (13).
10. Disconnect tube (19) from RET port (20) of valve (13).
11. Connect hose (21) to tubes (17 and 19).

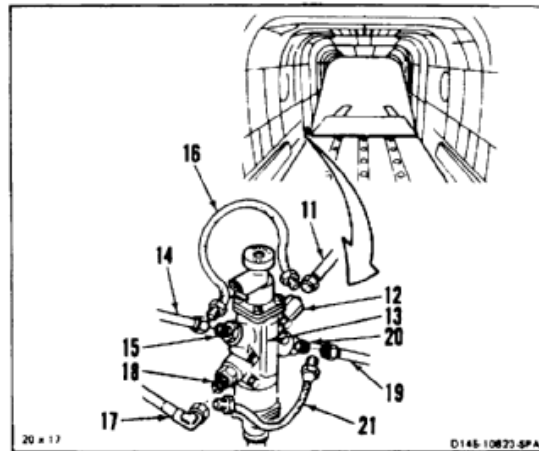

12. Disconnect tube (22) from C port (23) of cargo door pressure actuated valve (24).
13. Disconnect tube (25) from D port (26) of valve (24).
14. Connect hose (27) to tubes (22 and 25).

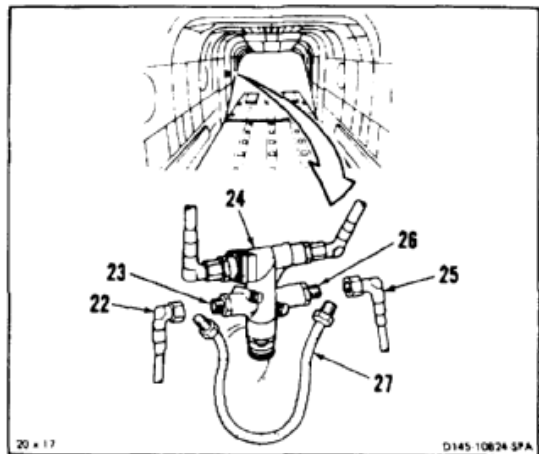

15. Tag and disconnect RAMP UNLOCK hose (28) from top port (29) of right ramp actuator (30).
16. Install plug (31) on hose (28).
17. Tag and disconnect RAMP DOWN hose (32) from middle port (33) of actuator (30).
18. Tag and disconnect RAMP UP hose (34) from lower port (35) of actuator (30).
19. Connect hose (32) to hose (34).

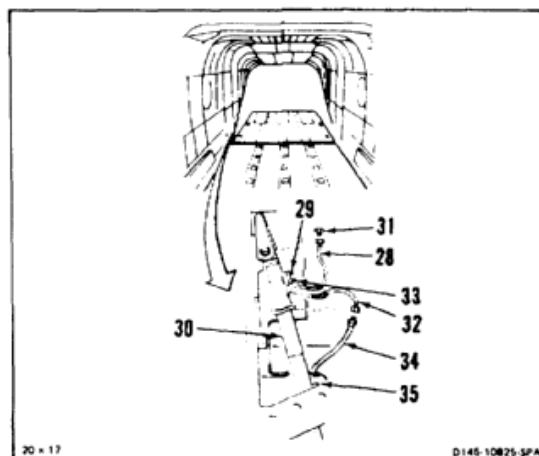

20. Tag and disconnect three hoses (36, 37, and 38) from left ramp actuator (39).
21. Connect two hoses (36 and 37) to tee (40).
22. Connect hose (41) to tee (40) and tee (42).
23. Connect hose (38) to tee (42).
24. Connect test stand return hose (43) to tee (42).

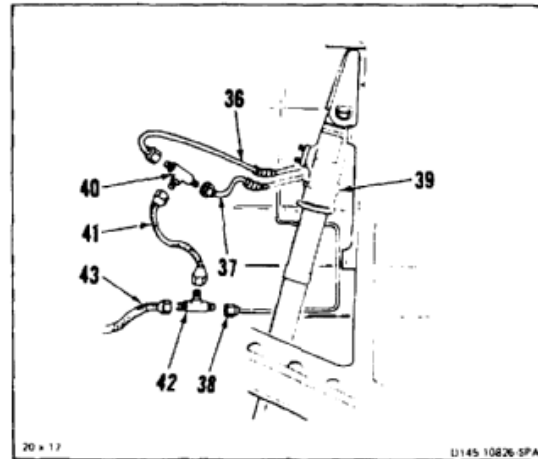

25. Working at aft right landing gear, tag and disconnect DOOR EXTEND hose (44) from filling (45) on ramp (46).
26. Tag and disconnect DOOR RETRACT hose (47) from filling (48) on ramp (46).
27. Connect hose (47) to hose (44).



Do not exceed **500 psi**. Otherwise damage to components can occur.



Keep test stand bypass valve closed. Otherwise, contaminants could re-enter the system.

28. Apply hydraulic power. Set stand to **10 gpm at 500 psi**. Flush system for **15 minutes**. Check for leaks.
29. Remove hydraulic power.
30. Disconnect hose (44) from hose (47).
31. Connect DOOR EXTEND hose (44) to filling (45) on ramp (46). Remove tag.
32. Connect DOOR RETRACT hose (47) from fitting (48) on ramp (46). Remove tag.

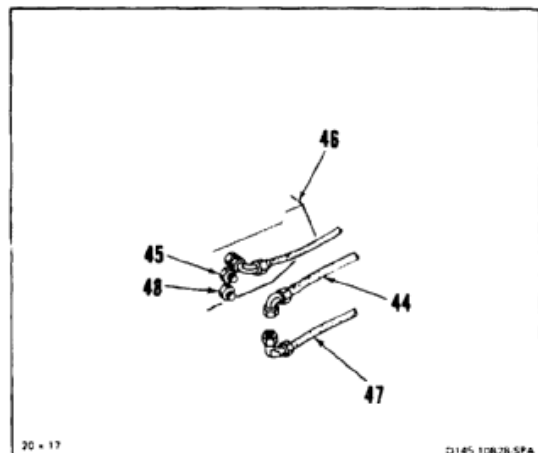
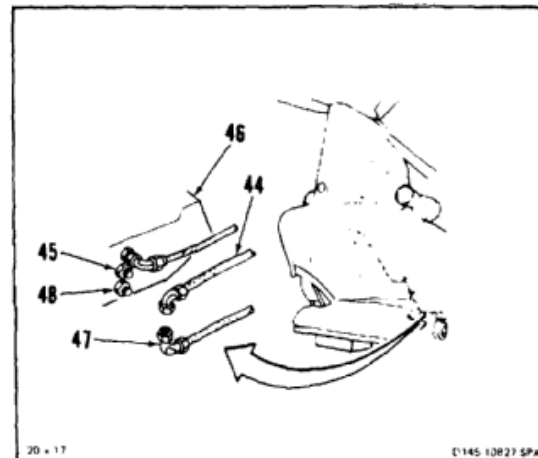

INSPECT

33. Disconnect hose (43) from tee (42) at left ramp actuator (39). Use container and cloths (E120) for spilled fluid. Use gloves (E186).
34. Disconnect two hose (41 and 38) from tee (42).
35. Disconnect three hoses (41, 36 and 37) from tee (40).
36. Connect RAMP UP hose (38) to lower port (49) of actuator (39). Remove tag.
37. Connect RAMP DOWN hose (37) to middle port (50) of actuator (39). Remove tag.
38. Connect RAMP UNLOCK hose (36) to top port (51) of actuator (39). Remove tag.

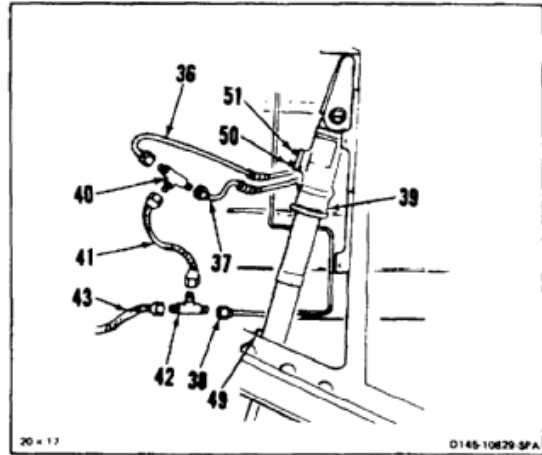

INSPECT

39. Disconnect hose (32) from hose (34) at right ramp actuator (30).
40. Connect RAMP UP hose (34) to lower port (35) of actuator (30). Remove tag.
41. Connect RAMP DOWN hose (32) to middle port (33) of actuator (30). Remove tag.
42. Remove plug (31) from hose (28).
43. Connect RAMP UNLOCK hose (28) to top port (29) of actuator (30). Remove tag.

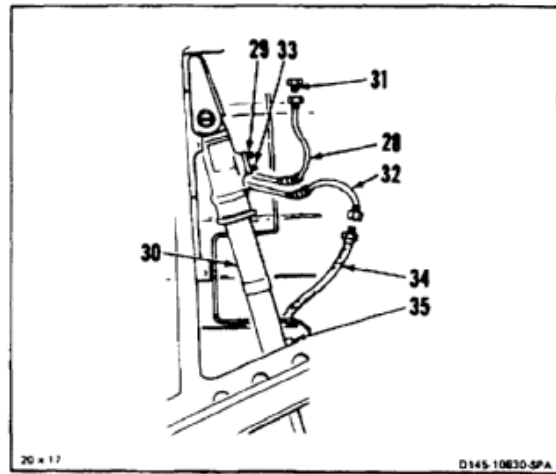

INSPECT

44. Disconnect hose (27) from tubes (22 and 25).
45. Connect tube (22) to port (23) of valve (24).
46. Connect tube (25) to port (26) of valve (24).

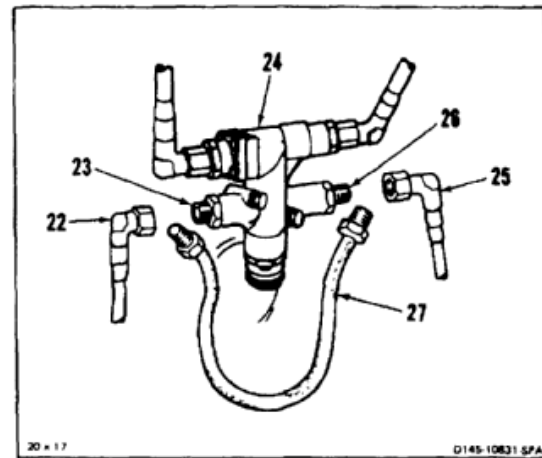

47. Disconnect hose (21) from tubes (17 and 19).
48. Connect tube (17) to port (18) of valve (13).
49. Connect tube (19) to port (20) of valve (13).
50. Disconnect hose (16) from tubes (14 and 11).
51. Connect tube (14) to port (15) of valve (13).
52. Connect tube (11) to port (12) of valve (13).

INSPECT

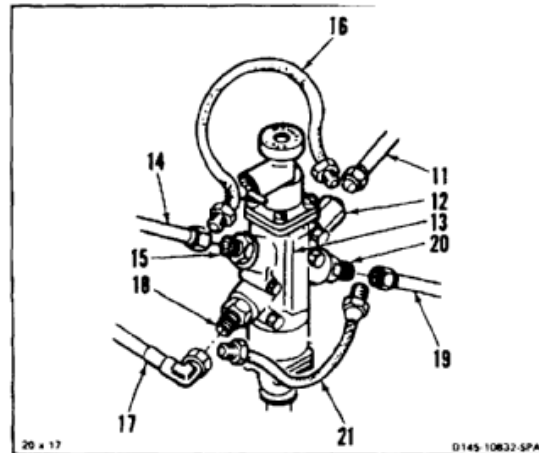

53. Disconnect hose (8) from tubes (9 and 10).
54. Disconnect hose (5) from tubes (6 and 7).

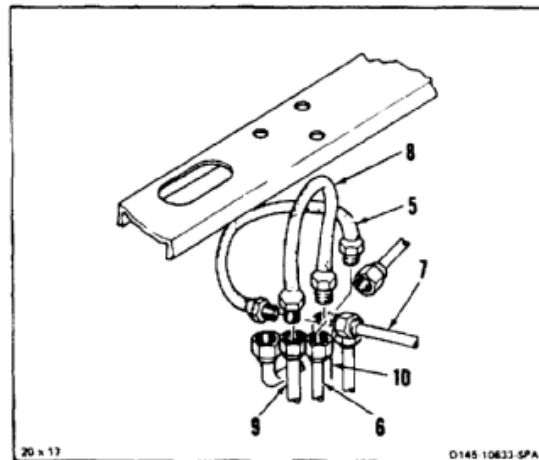

55. Disconnect hose (4) from port (2) of module (3).
56. Connect tube (1) to port (2) of module (3).

INSPECT

FOLLOW-ON MAINTENANCE:

- Install cargo ramp control valve (Task 7-270).
- Perform operational check of cargo ramp (TM 55-1520-240-T).
- Close cargo ramp (TM 55-1520-240-T).

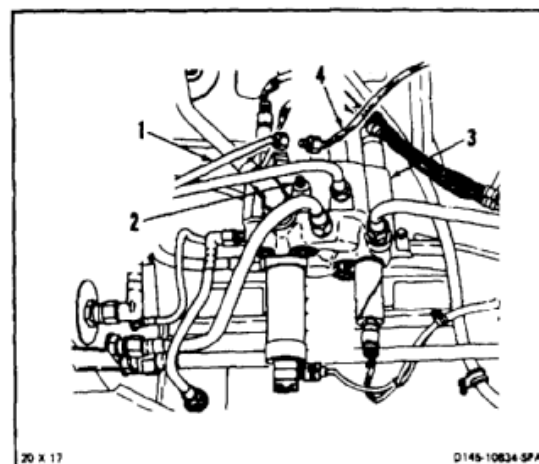

END OF TASK

INITIAL SETUP

Applicable Configurations:

All

Tools:

Hydraulic Repairer's Tool Kit, NSN 5180-00-323-4891
 Test Stand
 Filter Assembly Kit ADHT6814-M9716M
 Hoses
 Container, 2 Quart

Materials:

Cloths (E120)
 Paper Tags (E264)
 Gloves (E186)

Personnel Required:

Aircraft Pnedraulics Repairer (2)
 Inspector

Equipment Condition:

Battery Disconnected (Task 1-39)
 Electrical Power Off
 Hydraulic Power Off
 Utility Hydraulic System Depressurized (Task 7-135.1)
 Cargo Ramp Fully Down (TM 55-1520-240-T)
 Cargo Ramp Panel Removed (Task 2-2)
 Cargo Door Motor Removed (Task 7-285)

General Safety Instructions:**WARNING**

Hydraulic fluid (E199) is toxic. It can irritate skin and cause burns. Avoid inhaling. Use only with adequate ventilation. Avoid contact with skin, eyes, or clothing. In case of contact, immediately flush skin or eyes with water for at least **15 minutes**. Get medical attention for eyes.

WARNING

Hydraulic fluid ejected under pressure can cause injury to personnel. Hydraulic fluid sprayed into the air is a fire hazard.

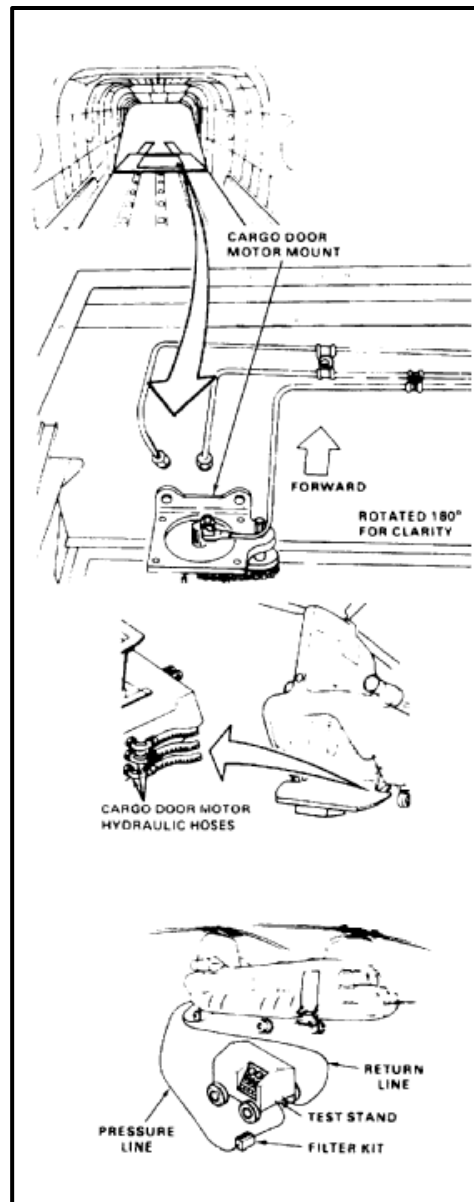

CAUTION

Filter assembly kit ADHT6814-M9716M must be installed in test stand pressure line. Otherwise, system can be contaminated.

NOTE

To operate hydraulic test, stand refer to applicable manual.

1. Working through cargo ramp panel, connect hose (1) to tube (2) and tee (3).
2. Connect hose (4) to tube (5) and tee (3).
3. Connect hose (6) to tube (7) and tee (3).
4. Working from ramp forward right side, tag and disconnect three hoses (8, 9, and 10) from elbows (11, 12, and 13).
5. Connect test stand pressure hose (14) to elbow (11).
6. Connect hose (15) to elbow (12) and tee (16).
7. Connect hose (17) to elbow (13) and tee (16).
8. Connect test stand return hose (18) to tee (16).

CAUTION

Do not exceed **500 psi**. Otherwise damage to components can occur.

CAUTION

Keep test stand bypass valve closed. Otherwise, contaminants could re-enter the system.

9. Apply hydraulic power. Set stand to **10 gpm at 500 psi**. Flush system for **15 minutes**. Check for leaks.
10. Move hydraulic power.
11. Disconnect hose (18) from tee (16). Use cloths (E120) and container for spilled fluid.

12. Remove two hoses (15 and 17) from tee (16) and elbows (12 and 13).
13. Remove hose (14) from elbow (11). Use cloths (E120) and container for spilled fluid. Use gloves (E186).
14. Connect UP RAMP hose (10) to elbow (13). Remove tag.
15. Connect DOWN RAMP hose (9) to elbow (12). Remove tag.
16. Connect RETURN hose (8) to elbow (11). Remove tag.

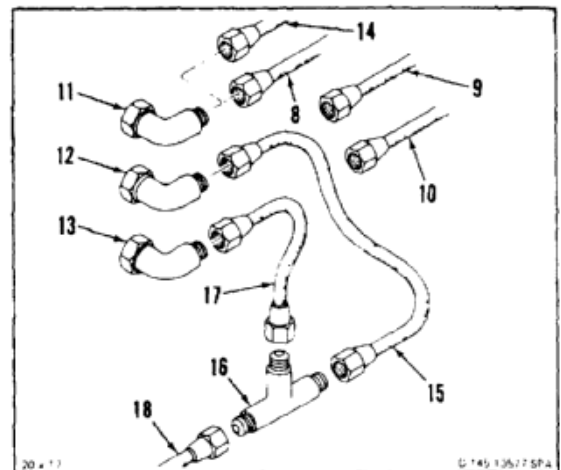
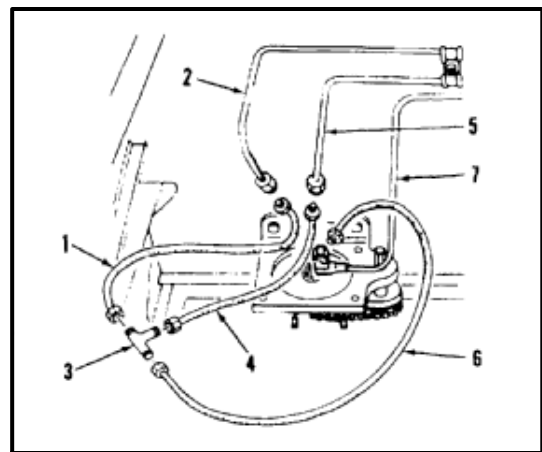
INSPECT

17. Working through cargo ramp panel, disconnect hose (6) from tube (7) and tee (3). Use cloths (E120) for spilled fluid. Use gloves (E186).
18. Disconnect hose (4) from tube (5) and tee (3). Use cloths (E120) for spilled fluid.
19. Disconnect hose (1) from tube (2) and tee (3). Use cloths (E120) for spilled fluid.

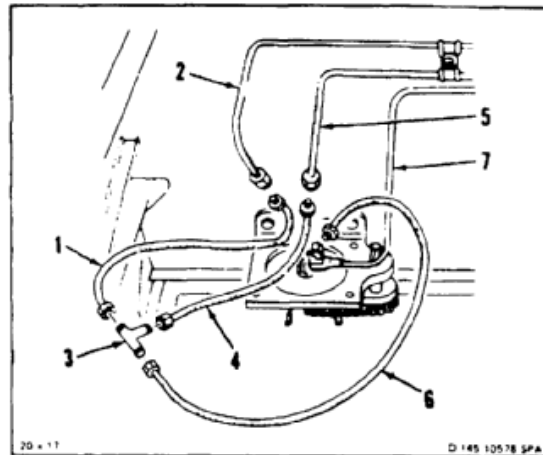
***FOLLOW-ON MAINTENANCE:***

- Install cargo door motor (Task 7-289).
- Perform operational check of cargo door (TM 55-1520-240-T).
- Install ramp panel (Task 2-249).

END OF TASK

7-1196

INITIAL SETUP

Applicable Configurations:

All

Tools:

- Hydraulic Repairer's Tool Kit, NSN 5180-00-323-4891
- Hydraulic Test Stand
- Filter Assembly Kit ADHT6814-M9716M
- Hose
- Container, 2 Quart

Materials:

- Cloths (E120)
- Gloves (E186)

Personnel Required:

- Aircraft Pneudraulics Repairer (2)
- Inspector

Equipment Condition:

- Battery Disconnected (Task 1-39)
- Electrical Power Off

Hydraulic Power Off
 Utility Hydraulic System Depressurized (Task 7-135.1)
 Ramp Down and Level (TM 55-1520-240-T)

General Safety Instructions:

WARNING

Hydraulic fluid (E199) is toxic. It can irritate skin and cause burns. Avoid inhaling. Use only with adequate ventilation. Avoid contact with skin, eyes, or clothing. In case of contact, immediately flush skin or eyes with water for at least **15 minutes**. Get medical attention for eyes.

WARNING

Hydraulic fluid ejected under pressure can cause injury to personnel. Hydraulic fluid sprayed into the air is a fire hazard.

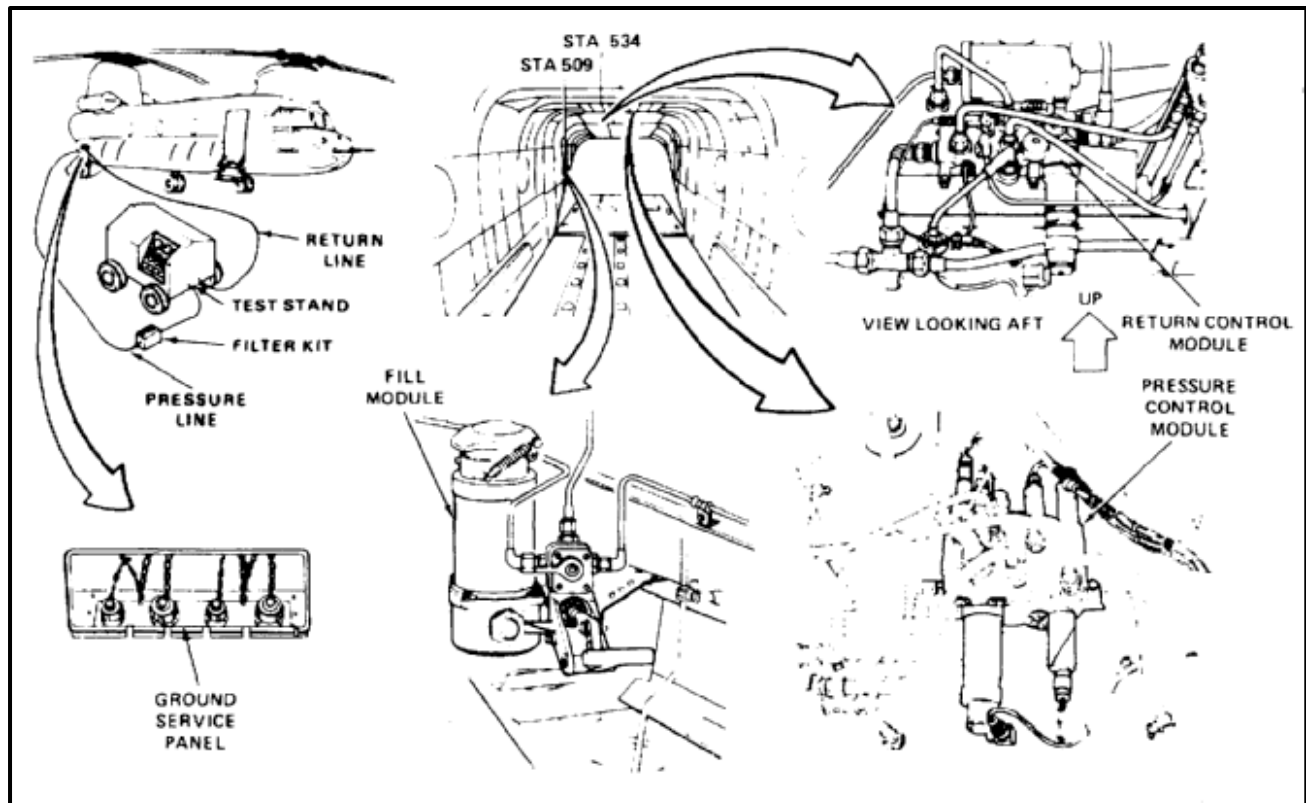

CAUTION

Filter assembly kit ADHT6814-M9716M must be installed in test stand pressure line. Otherwise, system can be contaminated.

NOTE

To operate hydraulic test stand, refer to applicable manual.

1. Working from ramp, disconnect RSVR RTN tube (1) from pressure control module (2).
2. Connect test stand pressure hose (3) to RSVR RTN port (4) of module (2).
3. Disconnect UTIL CONT RTN tube (5) and FILL tube (6) from return control module (7).
4. Connect hose (8) to port (9) and port (10) of module (7).

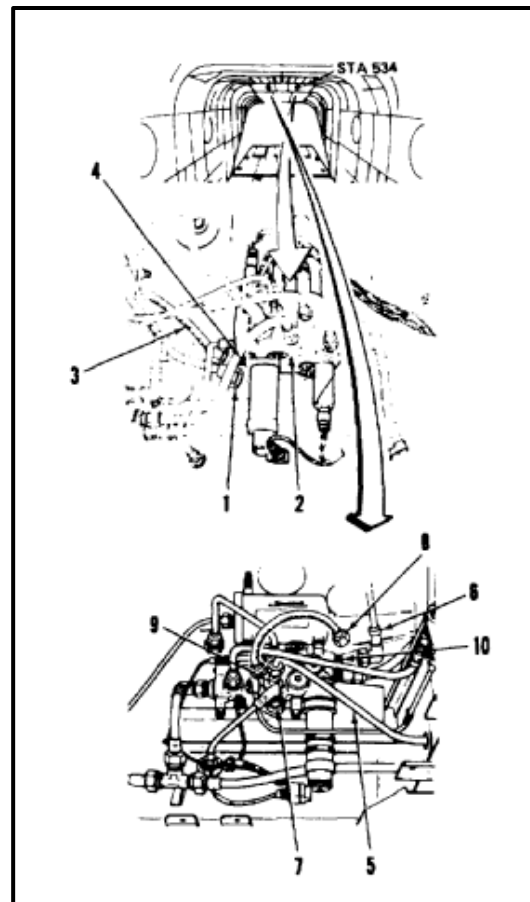

5. Disconnect FILL tube (11) from fill module (12).
6. Install plug (13) in tube (11).

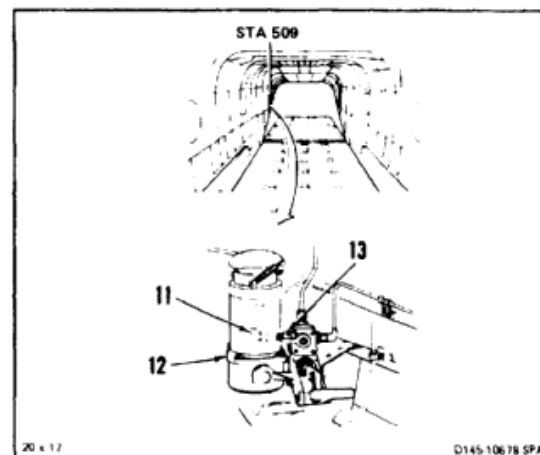

7. Working outside aft light, remove dust cap (14) from return port (15) of ground service panel (16).
8. Connect test stand return hose (17) to port (15).



Do not exceed **500 psi**. Otherwise damage to components can occur.



Keep test stand bypass valve closed. Otherwise, contaminants could re-enter the system.

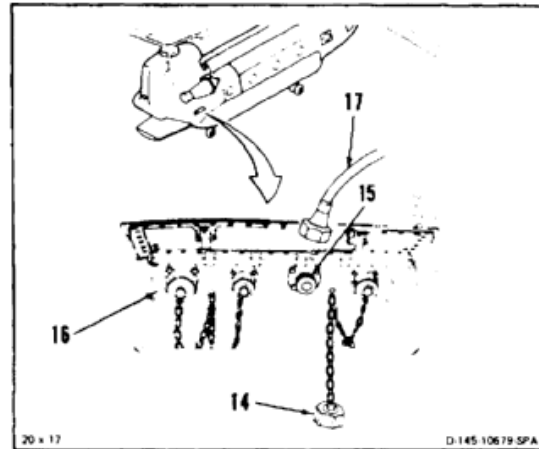

9. Apply hydraulic power. Set stand to **10 gpm at 500 psi**. Flush system for **15 minutes**. Check for leaks.
10. Remove hydraulic power.
11. Disconnect hose (17) from port (15). Use container and cloths (E120) for spilled fluid. Use gloves (E186).
12. Install cap (14) on port (15).
13. Working from ramp, remove plug (13) from tube (11) of module (12).

14. Connect stand return hose (17) to tube.



Do not exceed **500 psi**. Otherwise damage to components can occur.



Keep test stand bypass valve closed. Otherwise, contaminants could re-enter the system.

15. Apply hydraulic power. Set stand to **10 gpm at 500 psi**. Flush system for **15 minutes**. Check for leaks.
16. Remove hydraulic power.
17. Disconnect hose (17) from tube (11). Use container and cloths (E120) for spilled fluid.
18. Connect tube (11) to port (18) of module (12).
19. Disconnect hose (8) from two ports (9 and 10) of module (7).
20. Connect tube (5) to UTIL CONT RTN port (9) of module (7).
21. Connect tube (6) to FILL port (10) of module (7).

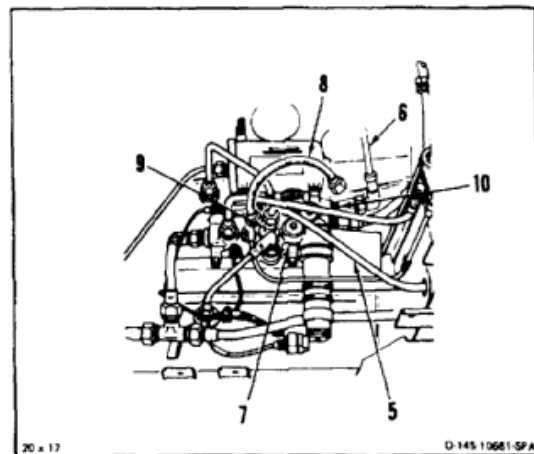
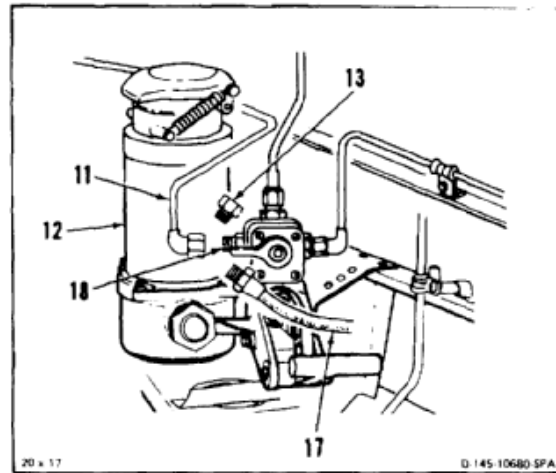

22. Disconnect hose (3) from port (4) of module (2).
Use container and cloths (E120) for spilled fluid.
23. Connect tube (1) to RSVR RTN port (4) of
module (2).

INSPECT**FOLLOW-ON MAINTENANCE:**

- Perform operational check of utility hydraulic system
(TM 55-1520-240-T).
- Close ramp (TM 55-1520-240-T).

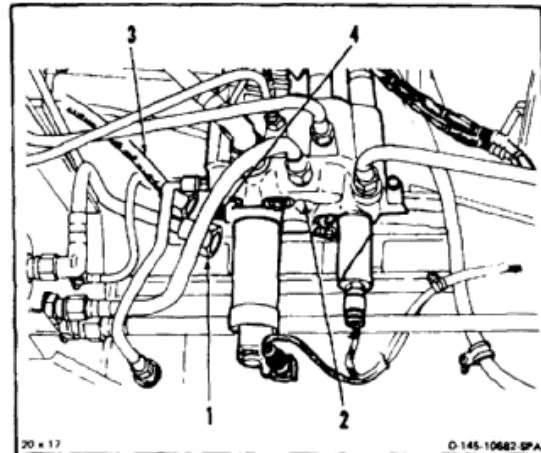

END OF TASK

INITIAL SETUP

Applicable Configurations:

All

Tools:

- Hydraulic Repairer's Tool Kit, NSN 5180-00-323-4891
- Hydraulic Test Stand
- Filter Assembly Kit ADHT6814-M9716M
- Hose
- Container, 2 Quart
- Workstand

Materials:

- Cloths (E120)
- Gloves (E186)

Personnel Required:

- Aircraft Pneudraulics Repairer (2)
- Inspector

Equipment Condition:

- Battery Disconnected (Task 1-39)
- Electrical Power Off

Hydraulic Power Off

Utility Hydraulic System Depressurized (Task 7-135.1)

Ramp Down and Level (TM 55-1520-240-T)

Aft Transmission Baffles Open (Task 2-2)

General Safety Instructions:

WARNING

Hydraulic fluid (E199) is toxic. It can irritate skin and cause burns. Avoid inhaling. Use only with adequate ventilation. Avoid contact with skin, eyes, or clothing. In case of contact, immediately flush skin or eyes with water for at least **15 minutes**. Get medical attention.

WARNING

Hydraulic fluid ejected under pressure can cause injury to personnel. Hydraulic fluid sprayed into the air is a fire hazard.

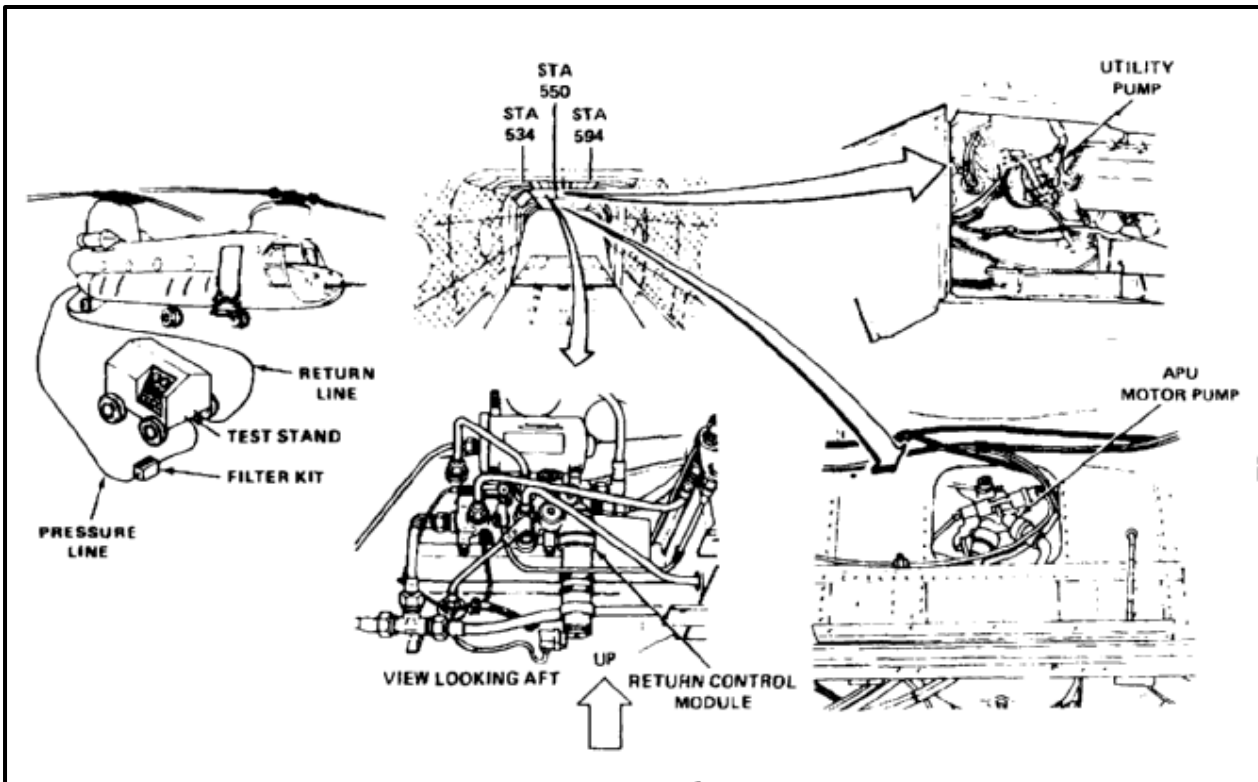

CAUTION

Filter assembly kit ADHT6814-M9716M must be installed in test stand pressure line. Otherwise, system can be contaminated.

NOTE

To operate hydraulic test stand, refer to applicable manual.

1. Working from ramp, disconnect UTIL PMP CD tube (1) from return control module (2).
2. Disconnect APU CD tube (3) from module (2).
3. Connect hose (4) to UTIL PMP CD port (5) and APU CD port (6) of module (2).
4. Disconnect CD tube (7) from utility pump (8).
5. Connect test stand return hose (9) to CD port (10) of pump (8).

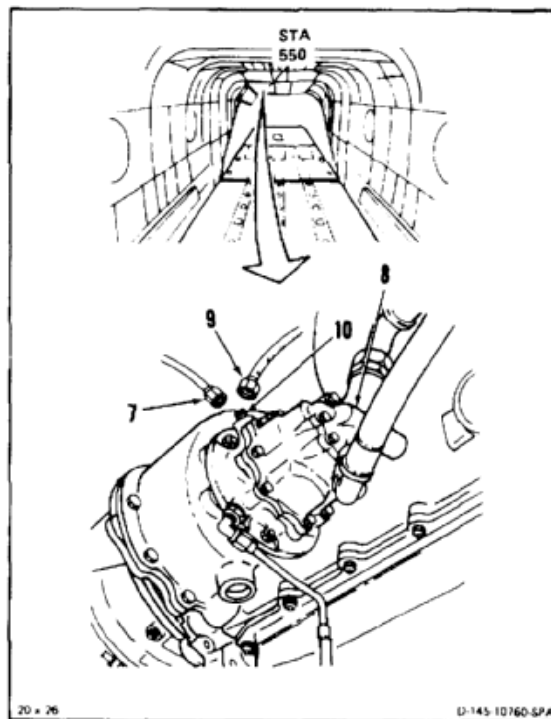
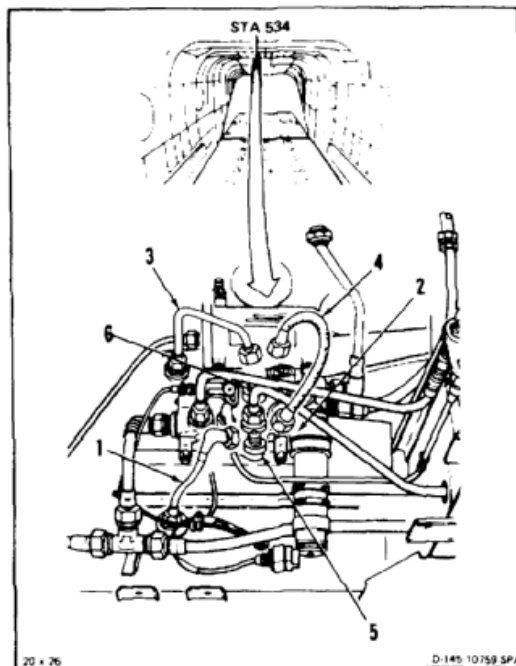

6. Disconnect CD tube (11) from APU motor pump (12).
7. Connect test stand pressure hose (13) to CD port (14) of pump (12).



Do not exceed **500 psi**. Otherwise damage to components can occur.



Keep test stand bypass valve closed. Otherwise, contaminants could re-enter the system.

8. Apply hydraulic power. Set stand to **10 gpm at 500 psi**. Flush system for **15 minutes**. Check for leaks.
9. Remove hydraulic power.
10. Disconnect hose (13) from pump (12). Use container and cloths (E120) for spilled fluid. Use gloves (E186).

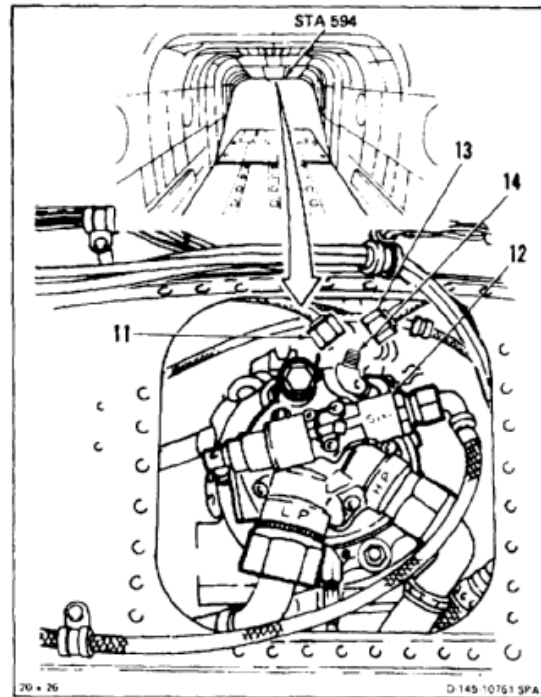

11. Connect tube (11) to CD port (14) of pump (12).
12. Disconnect hose (9) from pump (8). Use container and cloths (E120) for spilled fluid.
13. Connect tube (7) to CD port (10) of pump (8).

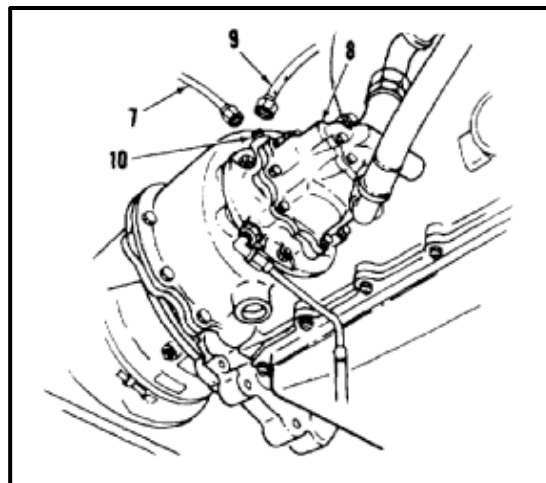

14. Disconnect hose (4) from ports (5 and 6) of module (2).
15. Connect tube (3) to APU CD port (6) of module (2).
16. Connect tube (1) to UTIL PMP CD port (5) of module (2).

INSPECT**FOLLOW-ON MAINTENANCE:**

- Install APU drip pan (Task 2-3).
- Close ramp (TM 55-1520-240-T).
- Close aft transmission baffles (Task 2-2).

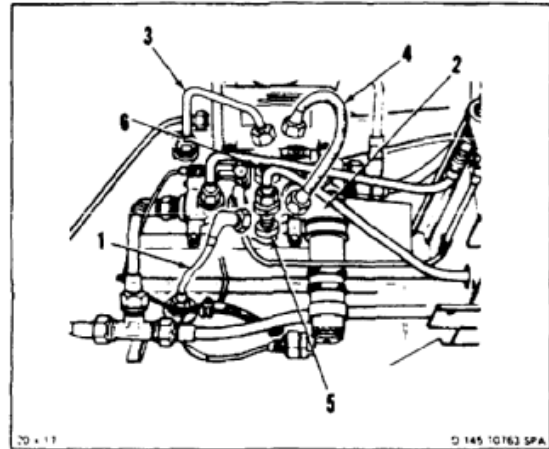

END OF TASK

INITIAL SETUP

Applicable Configurations:

All

Tools:

- Hydraulic Repairer's Tool Kit, NSN 5180-00-323-4891
- Hydraulic Test Stand
- Filter Assembly Kit ADHT6814M9716M
- Hoses
- Container, 2 Quart
- Workstand

Materials:

- Cloths (E120)
- Paper Tags (E264)
- Gloves (E186)

Personnel Required:

- Aircraft Pnedraulics Repairer (2)
- Inspector

Equipment Condition:

- Battery Disconnected (Task 1-39)
- Electrical Power Off
- Hydraulic Power Off

- Utility Hydraulic System Depressurized (Task 7-135.1)
- APU Start Accumulator Removed (Task 7-148)
- Cargo Ramp Down and Level (TM 55-1520-240-T)
- Pylon Right Access Panel Open (Task 2-2)
- Aft Transmission Baffles Open (Task 2-2)

General Safety Instructions:

WARNING

Hydraulic fluid (E199) is toxic. It can irritate skin and cause burns. Avoid inhaling. Use only with adequate ventilation. Avoid contact with skin, eyes, or clothing. In case of contact, immediately flush skin or eyes with water for at least **15 minutes**. Get medical attention for eyes.

WARNING

Hydraulic fluid ejected under pressure can cause injury to personnel. Hydraulic fluid sprayed into the air is a fire hazard.

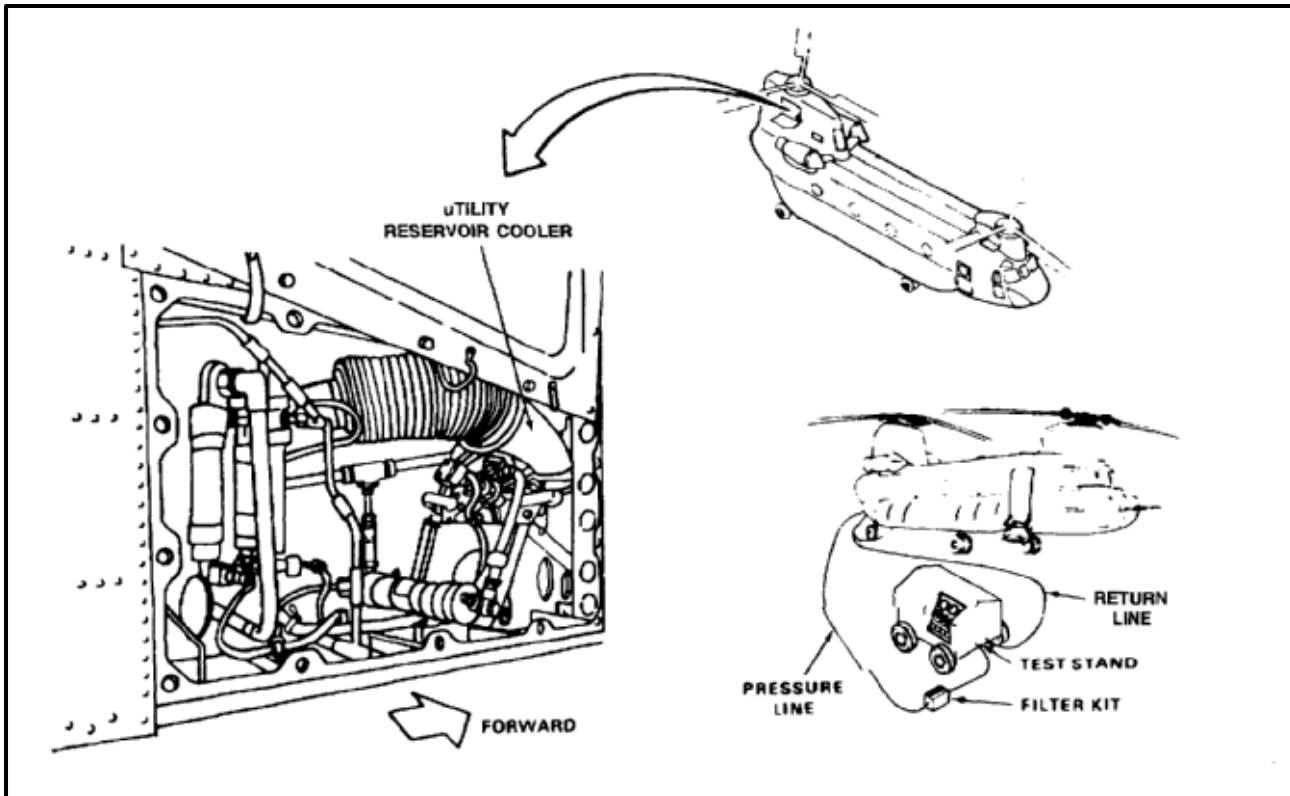

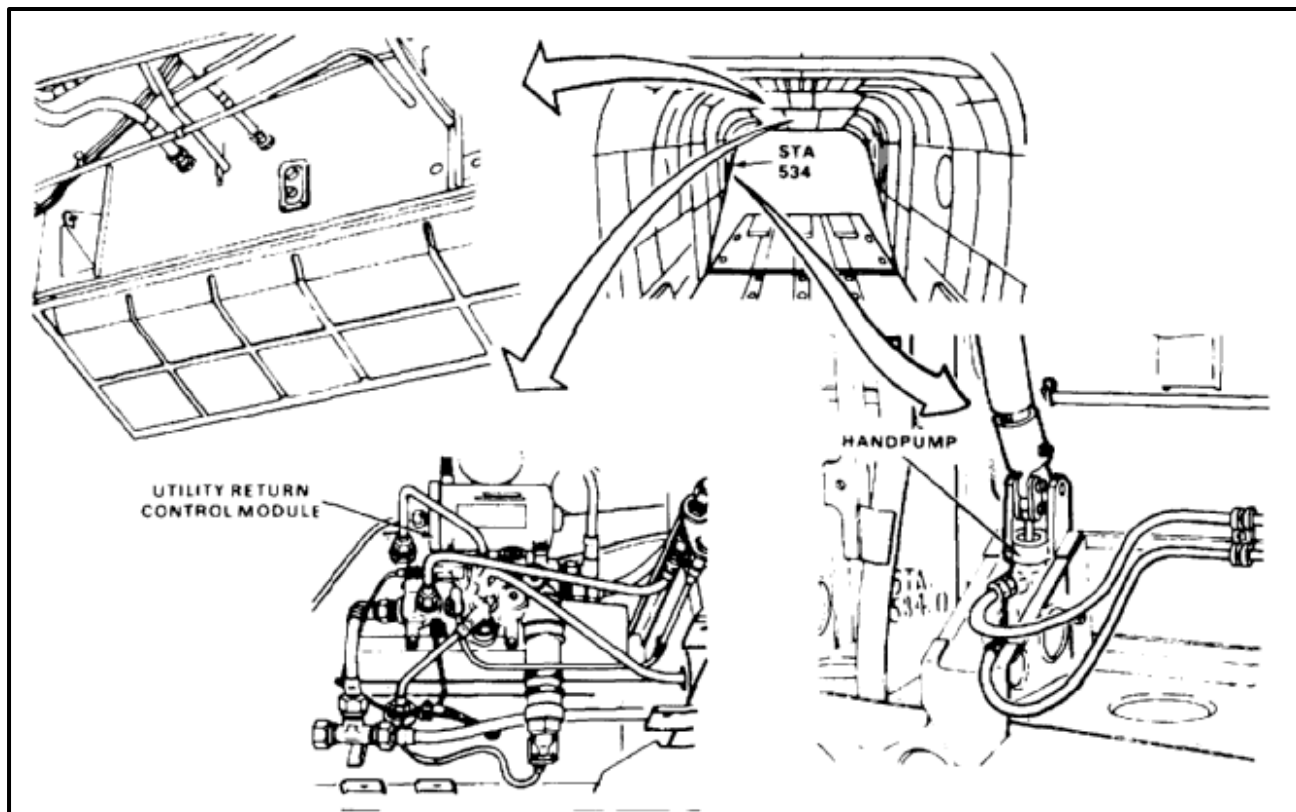

CAUTION

Filter assembly kit ADHT6814-M9716M must be installed in test stand pressure lines. Otherwise, system can be contaminated.

NOTE

To operate hydraulic test stand, refer to applicable manual.

1. Working from ramp, remove four bolts (1) and washers (2) from accumulator mount (3). Disconnect two tees (4 and 5) from mount. Remove mount.
2. Install plug (6) in return tee (5).
3. Disconnect tube (7) from RSVR port (8) of return control module (9).
4. Connect test stand pressure hose (10) to tube (7).

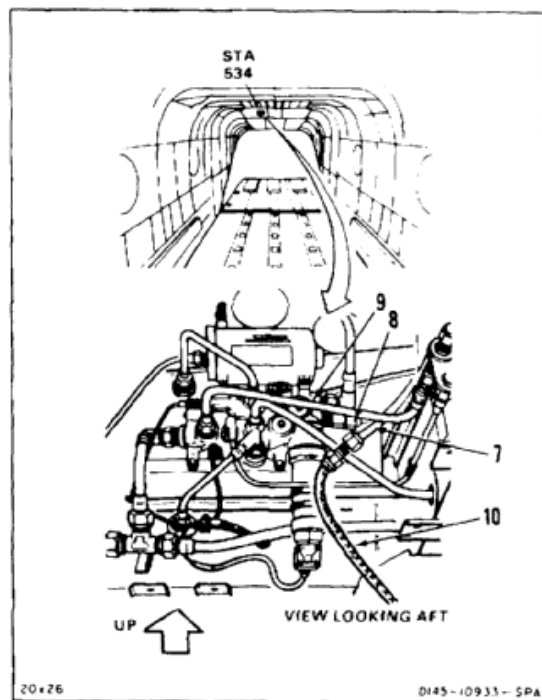
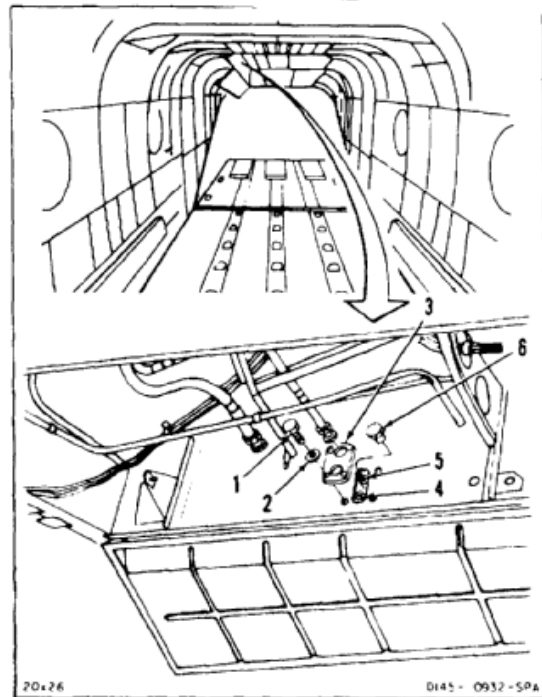

5. Working right of pylon, disconnect two tubes (11 and 12) from utility reservoir/cooler (13).
6. Connect hose (14) to tubes (11 and 12).

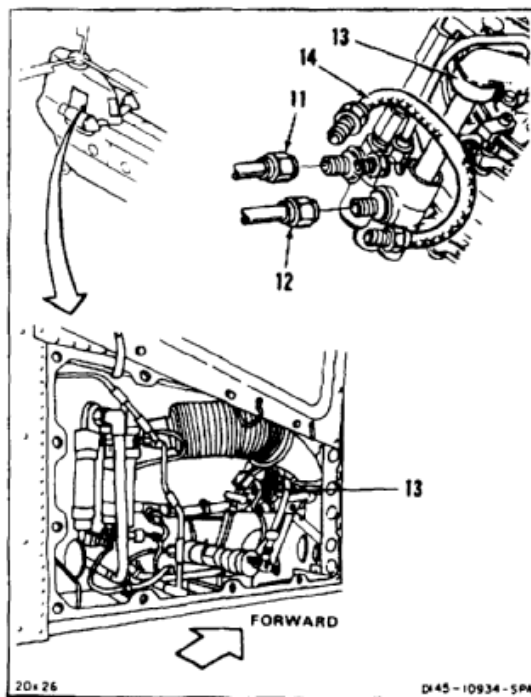

7. Disconnect tee fitting (15) from accumulator (16).
8. Install plug (17) in fitting (15).

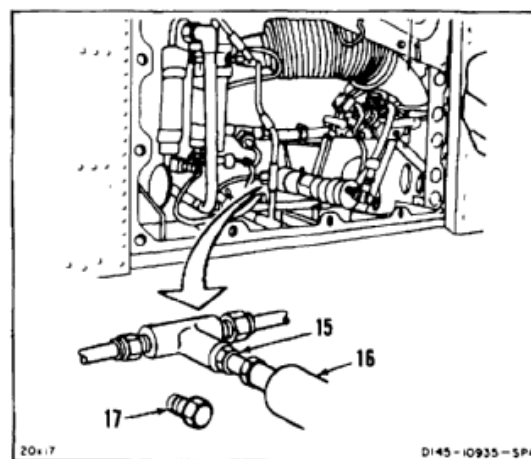

9. Working from ramp, tag and disconnect APU suction hose (18) from tee fitting (19). Use container and cloths (E120) for spilled fluid. Use gloves (E186).
10. Install cap (20) on fitting (19).
11. Tag and disconnect UTIL PUMP RETURN hose (21) from fitting (22).
12. Install cap (23) on fitting (22).

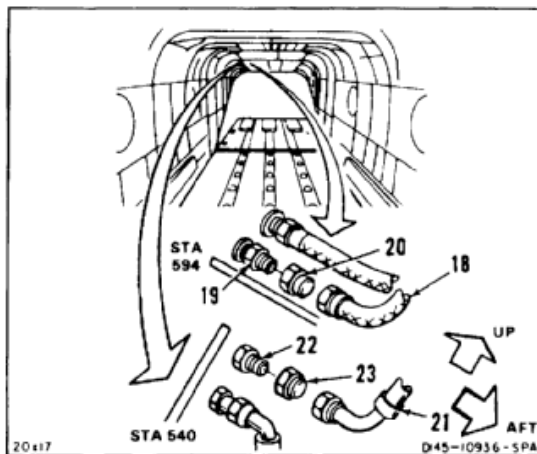

13. Disconnect tube (24) from RTN port (25) of hand pump (26).
14. Connect test stand return hose (27) to tube (24).



Do not exceed **500 psi**. Otherwise damage to components can occur.



Keep test stand bypass valve closed. Otherwise, contaminants could re-enter the system.

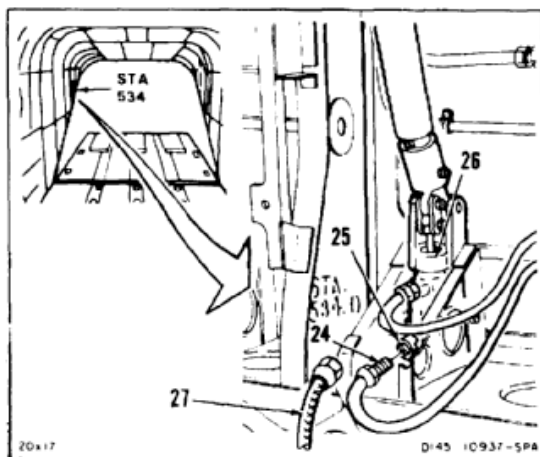

15. Apply hydraulic power. Set stand for **10 gpm at 500 psi**. Flush system for **15 minutes**. Check for leaks.
16. Remove hydraulic power.
17. Disconnect hose (27) from tube (24). Use container and cloths (E120) for spilled fluid.
18. Connect tube (24) to RTN port (25) of hand pump (26).

19. Remove cap (23) from fitting (22).
20. Connect UTIL PUMP RETURN hose (21) to fitting (22). Remove tag.
21. Remove cap (20) from fitting (19).
22. Connect hose (18) to fitting (19). Remove tag.

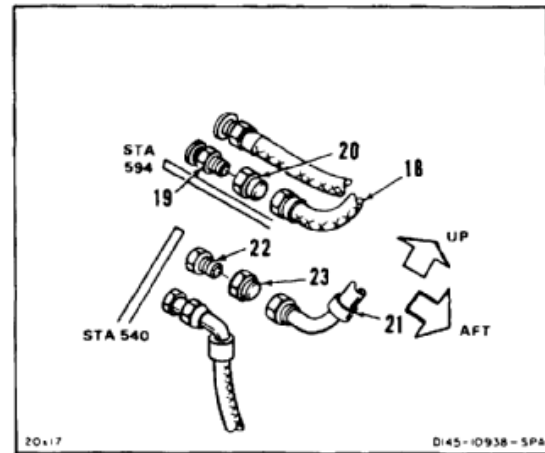

- 23. Working right of pylon remove plug (17) from fitting (15).
- 24. Connect fitting (15) to accumulator (16).

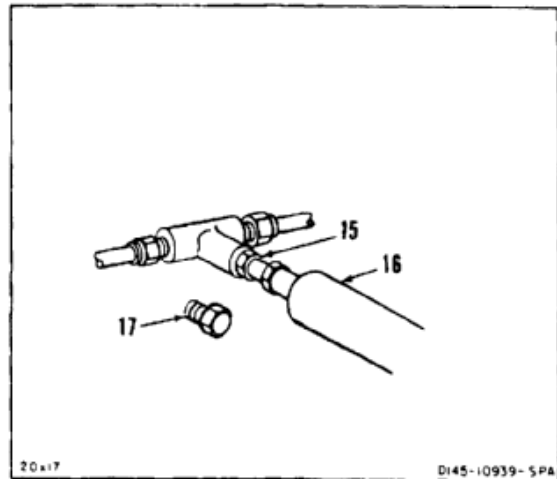

- 25. Disconnect hose (14) from tubes (11 and 12).
- 26. Connect two tubes (11 and 12) to reservoir/cooler (13).

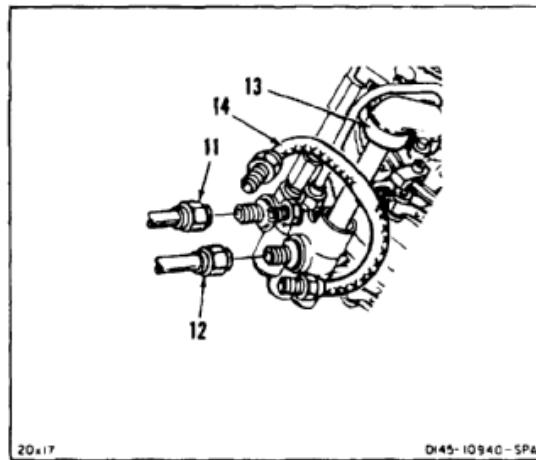

- 27. Working from ramp, disconnect hose (10) from tube (7). Use container and cloths (E120) for spilled fluid.
- 28. Connect tube (7) to RSVR port (8) of module (9).

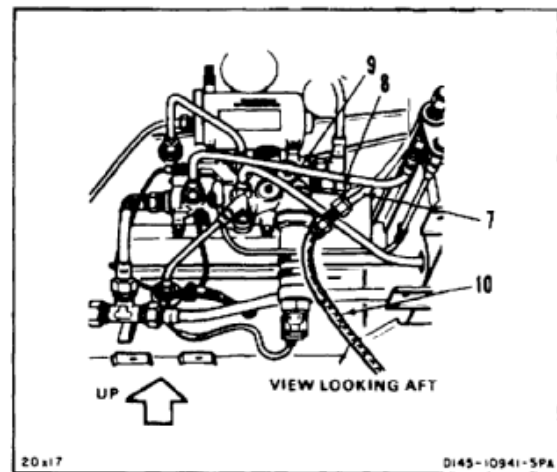

29. Remove plug (6) from tee (5).
30. Position accumulator mount (3) on tees (4 and 5). PRESS port (4) down.
31. Install four bolts (1) and washers (2) in mount (3).

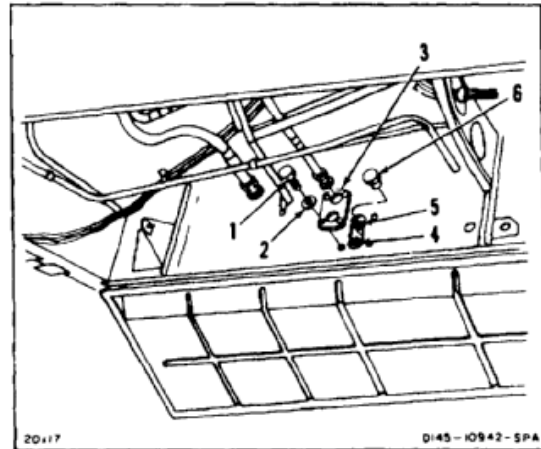
INSPECT**FOLLOW-ON MAINTENANCE:**

- Install APU start accumulator (Task 7-149).
- Perform operational check of utility hydraulic system (TM 55-1520-240-T).
- Close ramp (TM 55-1520-240-T).
- Close pylon right access panel (Task 2-2).

END OF TASK

INITIAL SETUP

Applicable Configurations:

All

Tools:

- Hydraulic Repairer's Tool Kit, NSN 5180-00-323-4891
- Hoses
- Container, 2 Quart (3)
- Hydraulic Test Stand
- Filter Assembly Kit ADHT6814-M9716M

Materials:

- Cloths (E120)
- Paper Tags (E264)
- Gloves (E186)

Personnel Required:

- Aircraft Pneudraulics Repairer (2)
- Inspector

Equipment Condition:

- Battery Connected (Task 1-39)
- Electrical Power Off
- Hydraulic Power Off

- Wheel Brake Accumulator Serviced (Task 1-67)
- Hydraulic Test Stand Connected to Ground Service Panel (Task 1-38)
- Forward Left Work Platform Open (Task 2-2)
- Aft Landing Gear Access Panels Open (Task 2-2)

General Safety Instructions:

WARNING

Hydraulic fluid (E199) is toxic. It can irritate skin and cause burns. Avoid inhaling. Use only with adequate ventilation. Avoid contact with skin, eyes, or clothing. In case of contact, immediately flush skin or eyes with water for at least **15 minutes**. Get medical attention for eyes.

WARNING

Hydraulic fluid ejected under pressure can cause injury to personnel. Hydraulic fluid sprayed into the air is a fire hazard.

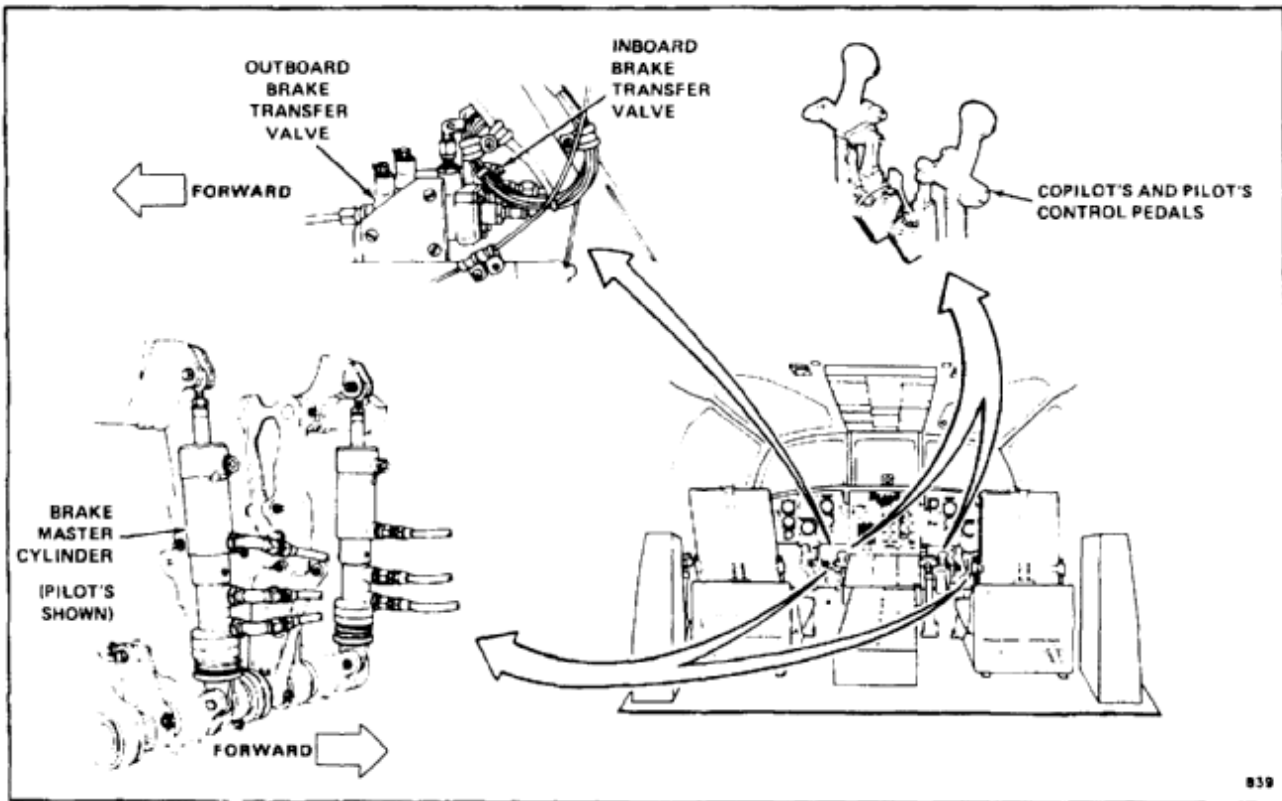

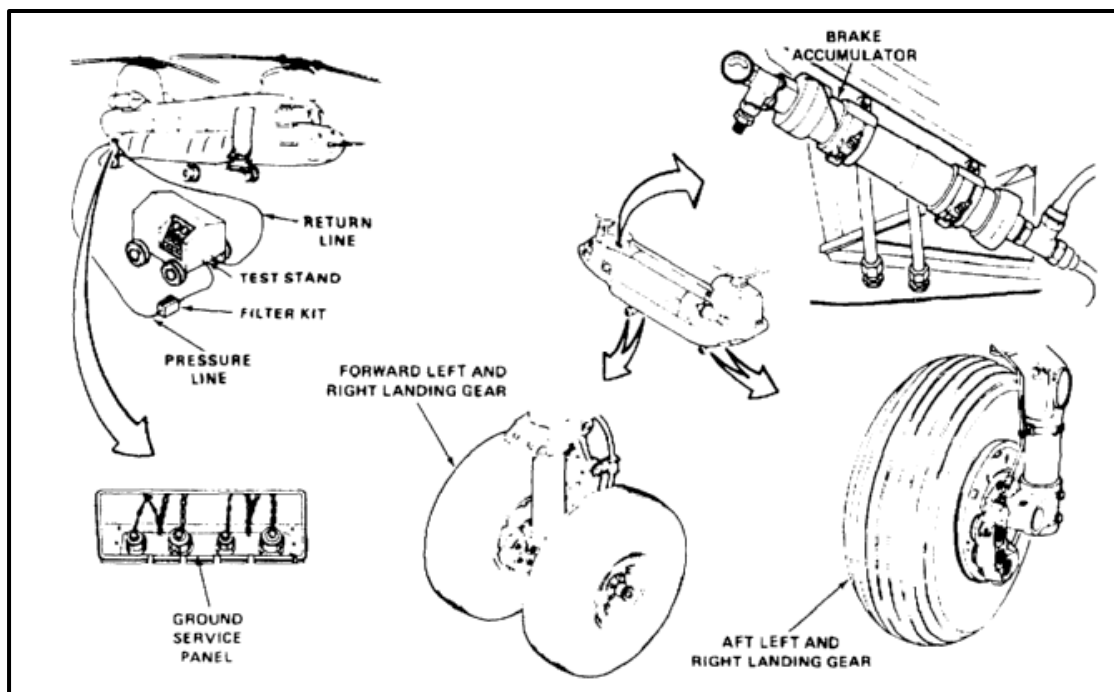

CAUTION

Filter assembly kit ADHT6814-M9716M must be installed in test stand pressure lines. Otherwise, system can be contaminated.

NOTE

To operate hydraulic test stand, refer to applicable manual.

PILOT'S RIGHT AND LEFT WHEEL BRAKE SYSTEM

1. Working in cockpit, tag and disconnect hose (1) from PRESS port (2) of pilot's right brake cylinder (3).
 2. Install cap (4) in port (2) of cylinder (3).
 3. Tag and disconnect hose (5) from RTN port (6) of cylinder (3).
 4. Install plug (7) in hose (5).
 5. Connect hose (1) to port (6) of cylinder (3).
 6. Remove bleed plug (8) from port (9) of cylinder (3).
 7. Connect hose (10) to port (9) of cylinder (3). Position loose end of hose in container.
 8. Install plug (11) in hose (10).
-
9. Working at right forward landing gear, connect bleed hoses (12) to bleed fittings (13) of two wheel brake cylinders (14 and 15). Position hoses in container.

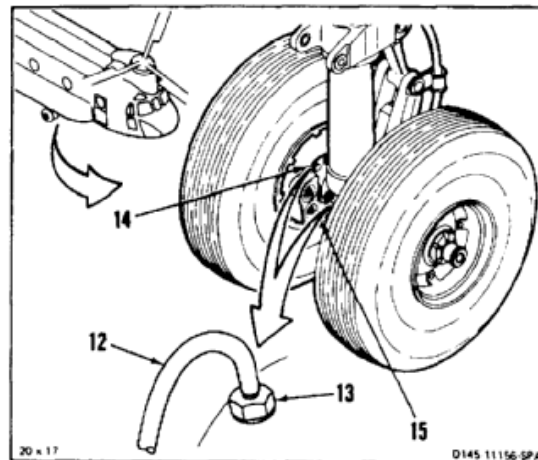
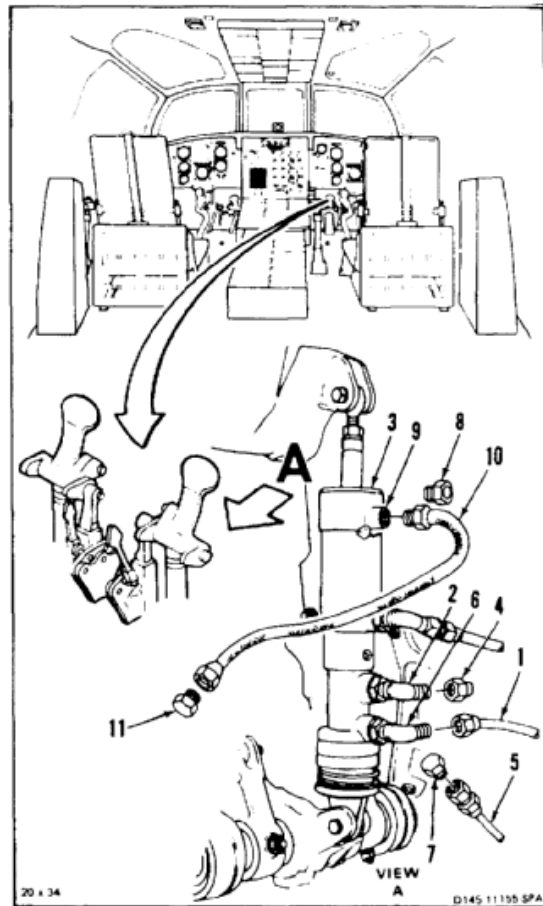

10. Working at right aft landing gear, connect bleed hose (16) to bleed fitting (17) of wheel brake cylinder (18).
11. Apply hydraulic power. Set stand for **3 gpm at 200 psi**.

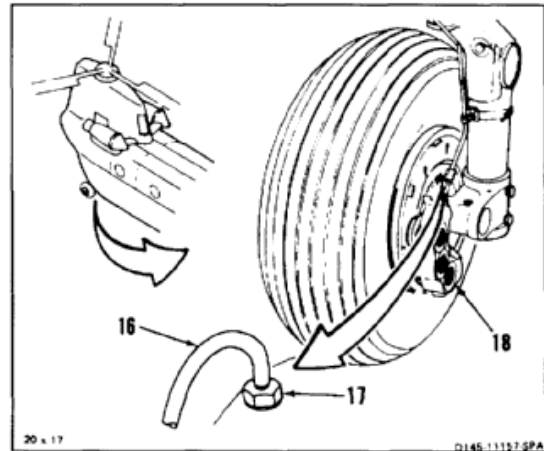

12. Loosen plug (11) in hose (10) from cylinder (3). Allow fluid to flow until air free. Tighten plug.

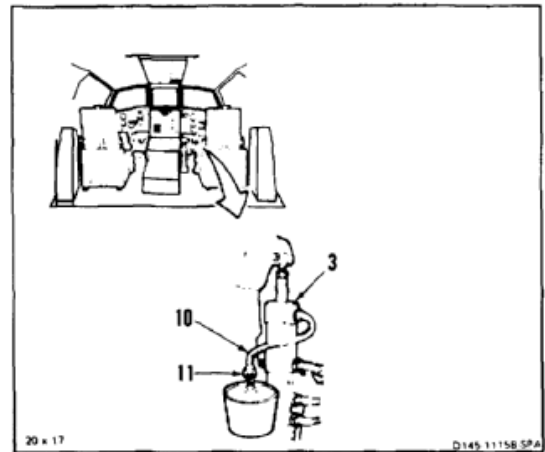

13. Working at right forward landing gear, loosen bleed fittings (13) of two cylinders (14 and 15). Allow fluid to flow until air free. Tighten fittings.
14. Disconnect hoses (12) from two cylinders (14 and 15).

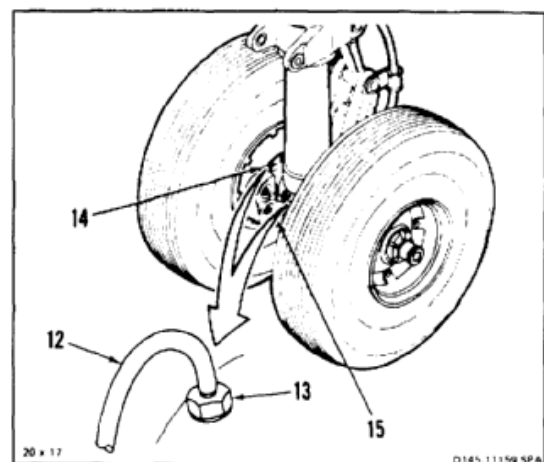

15. Working at right aft landing gear, loosen bleed fitting (17) of hose (16). Allow fluid to flow until air free. Tighten fitting.
16. Disconnect hose (16) from fitting (17) of cylinder.
17. Remove hydraulic power.

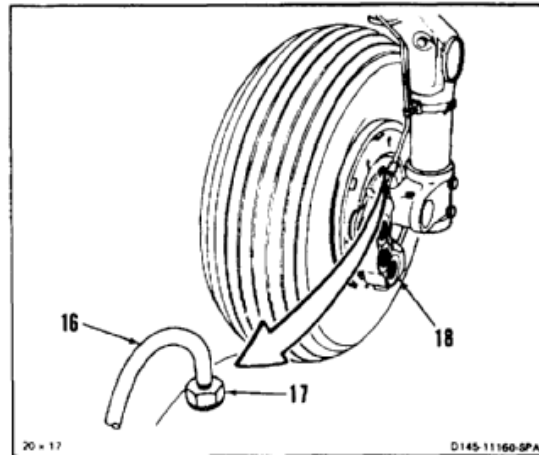

18. Working in cockpit, remove plug (11) from hose (10). Use cloth (E120) for spilled fluid. Use gloves (E186).
19. Disconnect hose (10) from port (9) of cylinder (3).
20. Install plug (8) in port (9).
21. Disconnect PRESS hose (1) from port (6) of cylinder (3).
22. Remove plug (7) from RETURN hose (5).
23. Connect hose (5) to RTN port (6) of cylinder (3). Remove tag.
24. Remove cap (4) from port (2).
25. Connect hose (1) to PRESS port (2) of cylinder (3). Remove tag.
26. Repeat steps 1 thru 26 for pilot's left brake cylinder and left forward and aft wheel brake cylinders.

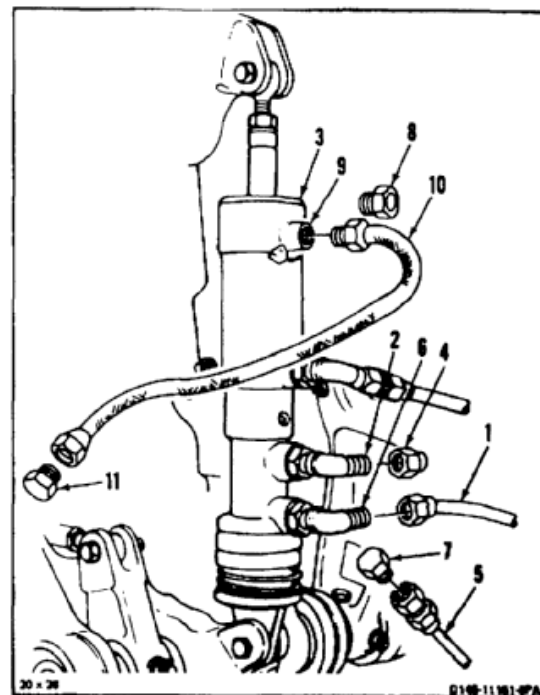

CO-PILOT'S RIGHT AND LEFT WHEEL BRAKE SYSTEM

27. Repeat steps 1 thru 8 for co-pilot's right brake cylinder.
28. Working left of console, connect bleed hose (19) to fitting (20) of inboard transfer valve (21).
29. Apply hydraulic power. Set stand for **3 gpm at 200 psi**.
30. Repeat step 12 for co-pilot's right cylinder.
31. Loosen fitting (20) of valve (21). Allow fluid to flow until air free. Tighten fitting.
32. Disconnect hose (19) from fitting (20).
33. Repeat steps 17 thru 25 for co-pilot's right cylinder.
34. Repeat steps 1 thru 8 for co-pilot's left brake cylinder.
35. Repeat steps 28 thru 32 for outboard transfer valve.
36. Repeat step 12 for co-pilot's left cylinder.
37. Repeat steps 31 and 32 for outboard transfer valve.
38. Working from forward left work platform, loosen nut (22) of brake accumulator (23). Allow fluid to flow until air free. Tighten nut. Use cloths (E120) for spilled fluid.
39. Repeat steps 17 thru 25 for co-pilot's left cylinder.

INSPECT**FOLLOW-ON MAINTENANCE:**

- Disconnect hydraulic test stand (Task 1-38).
- Close left work platform (Task 2-2).
- Close aft landing gear access panels (Task 2-2).

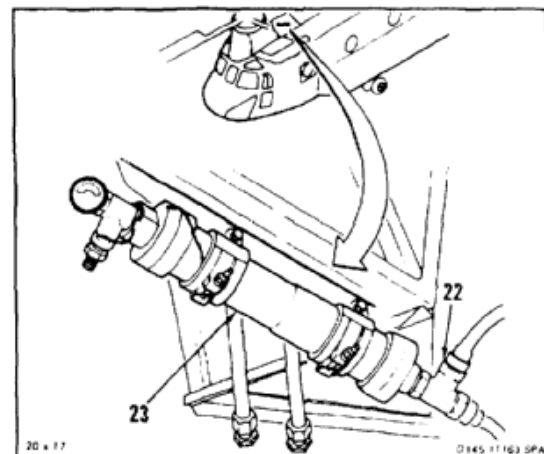
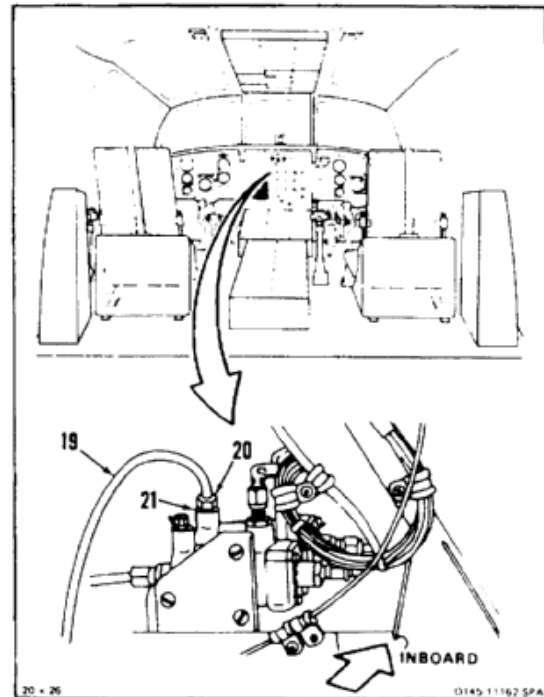

END OF TASK

INITIAL SETUP

Applicable Configurations:

All

Tools:

Hydraulic Repairer's Tool Kit, NSN 5180-00-323-4891
 Bleed Hose
 Container, 2 Quart
 Hydraulic Test Stand
 Filter Assembly Kit ADHT6814-M9716M

Materials:

Cloth (E120)
 Gloves (E186)

Personnel Required:

Aircraft Pneudraulics Repairer (2)
 Inspector

Equipment Condition:

Battery Connected (Task 1-39)
 Electrical Power Off
 Hydraulic Power Off
 Power Steering and Swivel Lock Accumulator
 Serviced (Task 1-66)
 Hydraulic Test Stand Connected to Ground Service
 Panel (Task 1-38)
 Aft Landing Gear Access Panels Open (Task 2-2)

General Safety Instructions:**WARNING**

Hydraulic fluid (E199) is toxic. It can irritate skin and cause burns. Avoid inhaling. Use only with adequate ventilation. Avoid contact with skin, eyes, or clothing. In case of contact, immediately flush skin or eyes with water for at least **15 minutes**. Get medical attention for eyes.

WARNING

Hydraulic fluid ejected under pressure can cause injury to personnel.
 Hydraulic fluid sprayed into the air is a fire hazard.

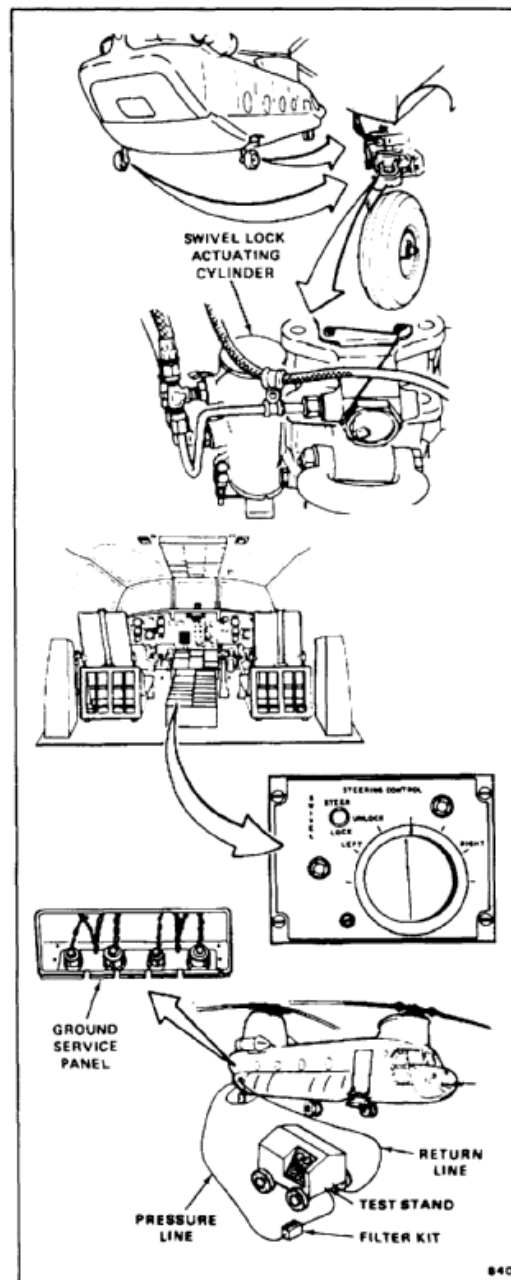

CAUTION

Filter assembly kit ADHT6814-M9716M must be installed in test stand pressure lines. Otherwise, system can be contaminated.

NOTE

To operate hydraulic test stand, refer to applicable manual.

1. Apply hydraulic pressure. Set stand to **3 gpm at 200 psi**.

CAUTION

Swivel lock actuator UNLOCK port is pressurized when swivel lock switch is ON or OFF.

2. Working at aft left landing gear, loosen nut (1) of hose (2) to UNLOCK port (3) of swivel lock actuator (4). Allow fluid to flow for **1 minute**, after fluid is air free. Tighten nut. Use container and cloths (E120) for spilled fluid. Use gloves (E186).
3. Repeat step 2 for aft right swivel lock actuator.
4. Working at aft left landing gear, remove plug (5) from centering cam (6).
5. Install bleeder hose (7) in port (8) of centering cam (6). Position hose in container.

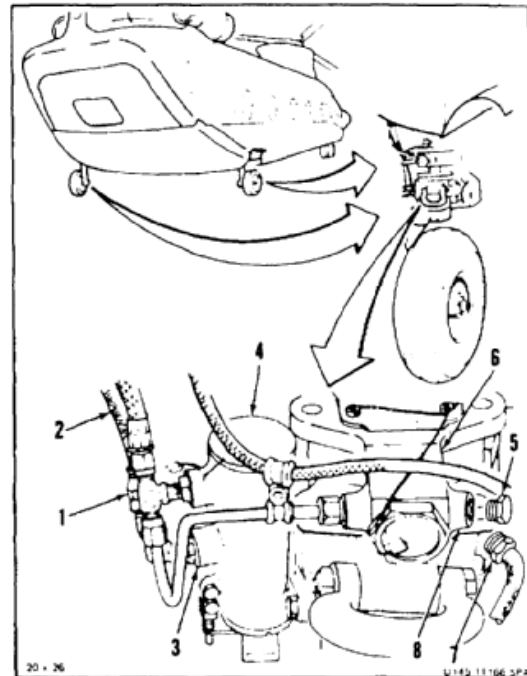

6. Working in cockpit, set SWIVEL switch (9) of STEERING CONTROL panel (10) to LOCK.

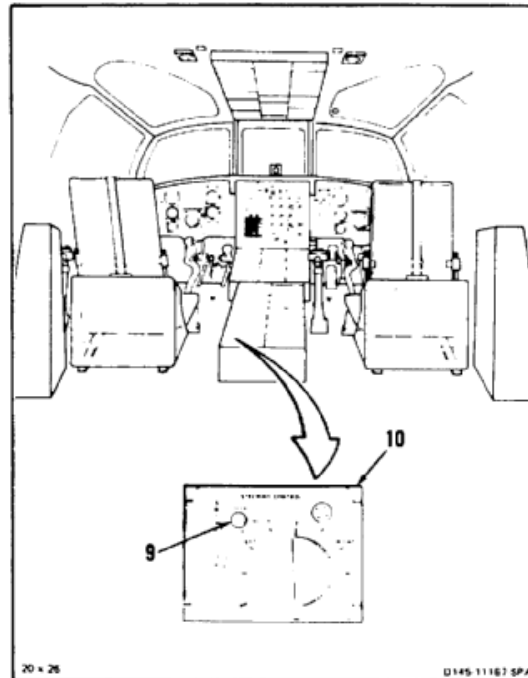

7. Working at aft left landing gear allow fluid to flow from hose (7) until air free.

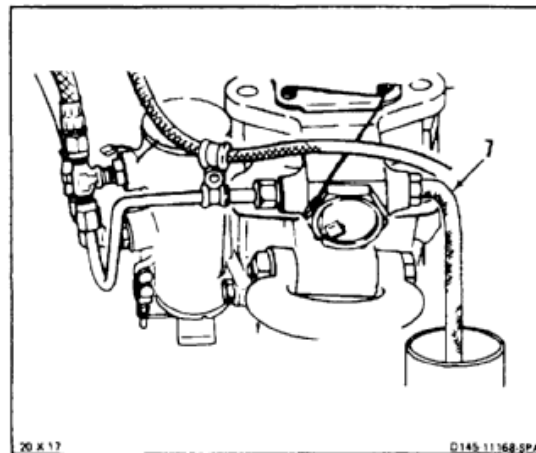

8. Working in cockpit, set SWIVEL switch (9) to UNLOCK.

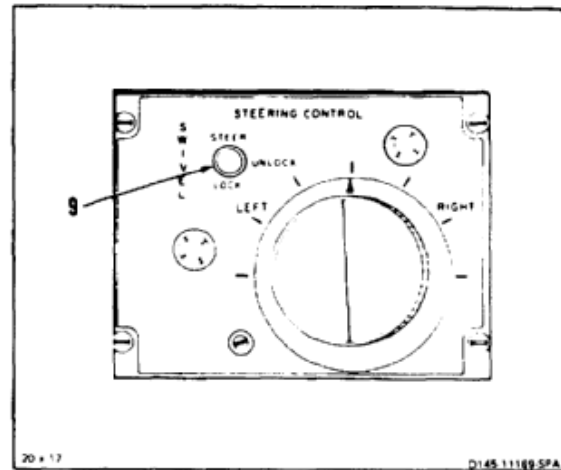

9. Working at aft left landing gear, disconnect hose (7) from cam (6).
10. Install plug (5) in port (8) of cam (6).
11. Repeat steps 4 thru 10 for right aft landing gear.

INSPECT

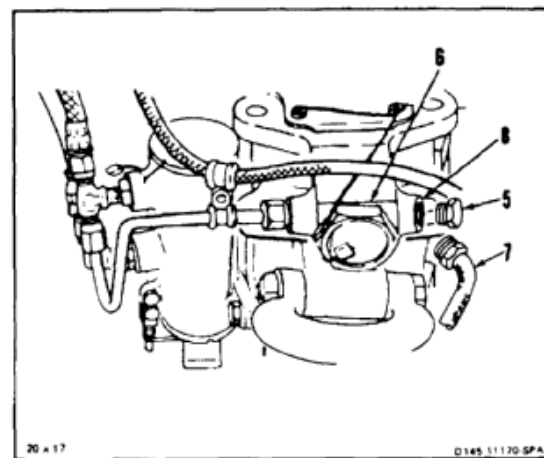

FOLLOW-ON MAINTENANCE:

- Disconnect hydraulic test stand (Task 1-38).
Close aft landing gear access panels (Task 2-2).

END OF TASK

INITIAL SETUP

Applicable Configurations:

All

Tools:

- Hydraulic Repairer's Tool Kit, NSN 5180-00-323-4891
- Hydraulic Test Stand
- Filter Assembly Kit ADHT6814-M9716M

Materials:

None

Personnel Required:

Aircraft Pneudraulics Repairer (2)

Equipment Condition:

- Battery Connected (Task 1-39)
- Electrical Power On
- Hydraulic Power Off
- Power Steering and Swivel Lock Accumulator Serviced (Task 1-66)
- Hydraulic Test Stand Connected to Ground Service Panel (Task 1-38)
- Aft Right Landing Gear Jacked (Task 1-24)
- Brake Steer Switch Set to On (Task 1-66)
- Aft Right Landing Gear Access Panel Open (Task 2-2)
- Steering Control Panel Swivel Switch Set to UNLOCK (TM 55-1520-240-T)

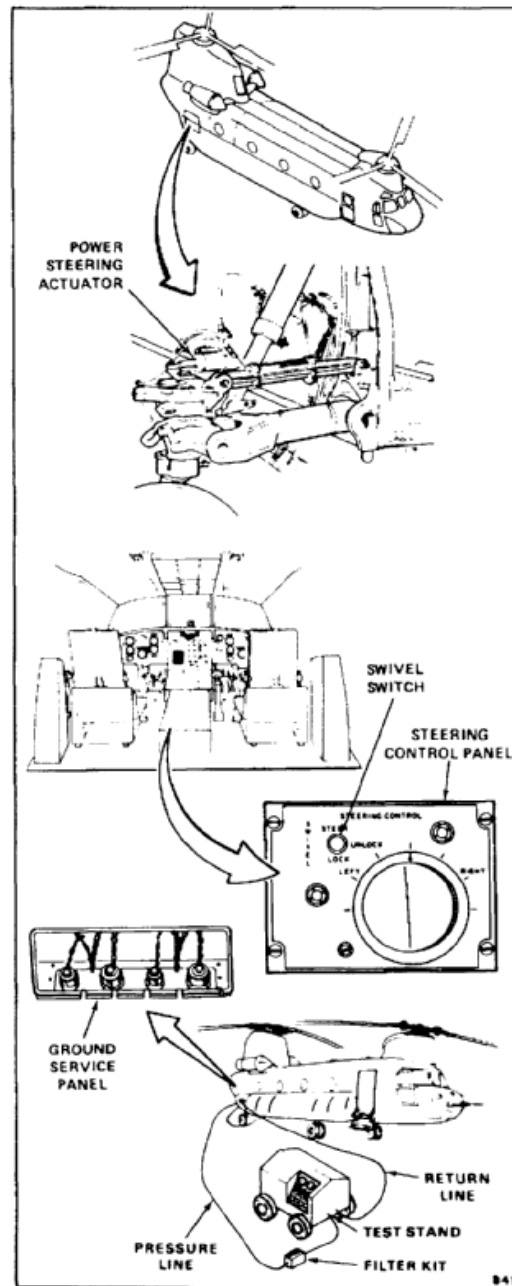

WARNING

Stand clear of wheel. Serious injury may occur during wheel movement.

CAUTION

Filter assembly kit ADHT6814-M9716M must be installed in test stand pressure lines. Otherwise, system can be contaminated.

NOTE

To operate hydraulic test stand, refer to applicable manual.

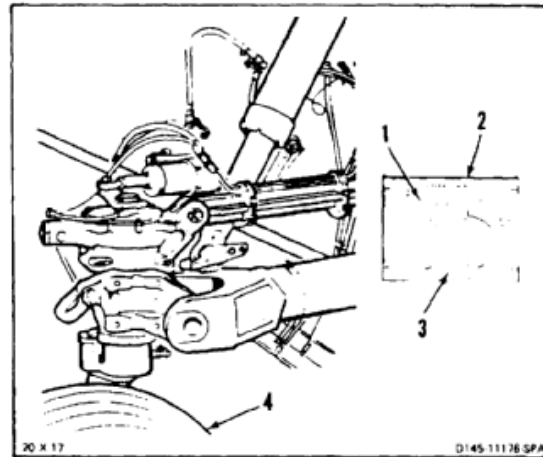

1. Apply hydraulic power. Set stand to **500 psi**.
2. Have helper in cockpit, set SWIVEL switch (1) of STEERING CONTROL panel (2) to STEER.
3. Rotate knob (3) of panel (2) fully left, then fully right.
4. Check movement of aft right wheel (4). Wheel must turn smoothly when knob (3) is rotated.
5. Repeat step 3 **ten times**.
6. Set knob (3) to mid-position.
7. Set switch (1) to UNLOCK.

FOLLOW-ON MAINTENANCE:

Remove electrical power (Task 1-37).
 Disconnect hydraulic test stand (Task 1-38).
 Lower and remove jack (Task 1-24).
 Close aft right landing gear access panel (Task 2-2).

END OF TASK

INITIAL SETUP

Applicable Configurations:

All

Tools:

Hydraulic Repairer's Tool Kit, NSN 5180-00-323-4891
 Container, 2 Quart
 Hydraulic Test Stand
 Filter Assembly Kit ADHT6814-M9716M

Materials:

Cloths (E120)
 Hydraulic Fluid (E199)
 Gloves (E186)

Parts:

Packing
 Washer

Personnel Required:

Aircraft Pneudraulics Repairer (2)

Equipment Condition:

Battery Connected (Task 1-39)
 Electrical Power On
 Hydraulic Power Off
 Hydraulic Test Stand Connected to Utility System
 Ground Service Panel (Task 1-38)
 Heater Compartment Acoustic Blanket Removed
 (Task 2-208)

General Safety Instructions:**WARNING**

Hydraulic fluid (E199) is toxic. It can irritate skin and cause burns. Avoid inhaling. Use only with adequate ventilation. Avoid contact with skin, eyes, or clothing. In case of contact, immediately flush skin or eyes with water for at least **15 minutes**. Get medical attention for eyes.

WARNING

Hydraulic fluid ejected under pressure can cause injury to personnel.
 Hydraulic fluid sprayed into the air is a fire hazard.

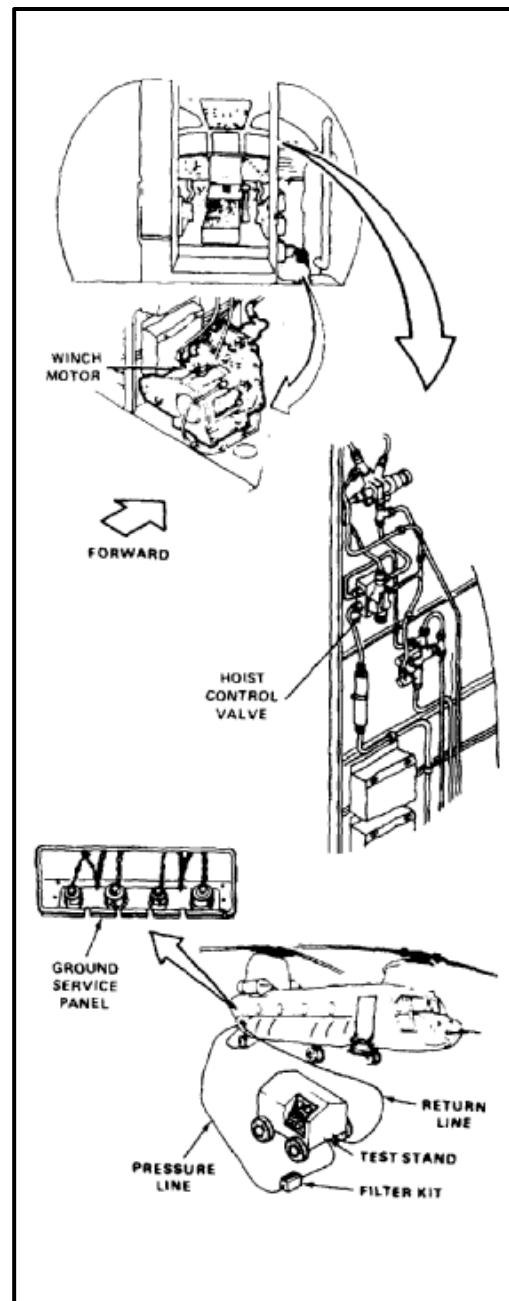

CAUTION

Filter assembly kit ADHT6814-M9716M must be installed in test stand pressure lines. Otherwise, system can be contaminated.

NOTE

To operate hydraulic test stand, refer to applicable manual.

1. Disconnect drain hose (1) from winch motor (2).
2. Loosen nut (3) of elbow (4). Remove elbow, packing (5), and washer (6).
3. Fill motor (2) through port (7) with fluid (E199). Tap motor with hammer soft-faced to remove trapped air.
4. Install washer (6) and packing (5) on elbow (4).
5. Install elbow (4). Do not tighten nut (3) at this time.

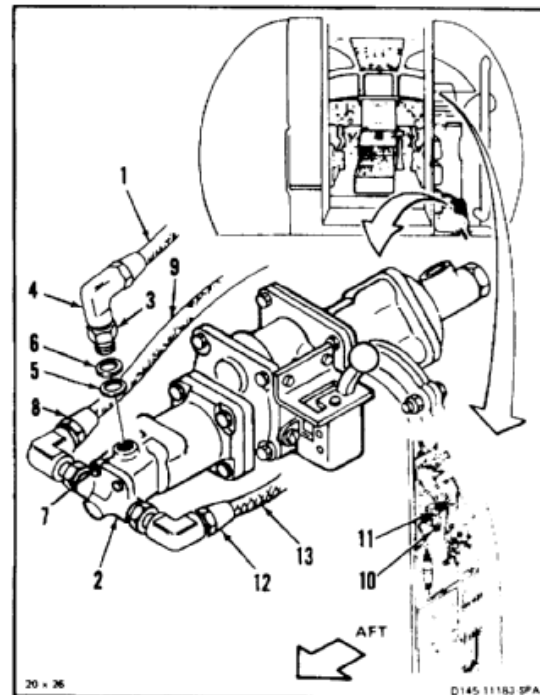

6. Connect hose (1) to elbow (4).
7. Apply hydraulic power. Set test stand to **5 psi**.
8. Loosen nut (8) of IN hose (9).
9. Turn knob (10) of control valve (11) forward until fluid flows from hose (9). Allow fluid to flow until air free. Use container and cloths (E120) for spilled fluid. Use gloves (E186).
- 9.1. Tighten nut (8) of IN hose (9).
10. Turn knob (10) to off position.
11. Loosen nut (12) of hose (13).
12. Turn knob (10) aft until fluid flows from hose (13). Allow fluid to flow until air free. Use container and cloths (E120) for spilled fluid. Use gloves (E186).
- 12.1. Tighten nut (12) of hose (13).
13. Turn knob (10) to off position.
14. Set stand pressure to **3000 psi**.

WARNING

Cable must be manually controlled during reel-in and reel-out to prevent entanglement, snags, and injury to personnel.

15. Turn knob (10) aft. Allow about **10 feet** of cable to reel-out.
16. Turn knob (10) forward. Allow cable to reel-in.
17. Remove hydraulic power.

FOLLOW-ON MAINTENANCE:

Disconnect hydraulic test stand from ground service panel (Task 1-38).
 Install heater compartment acoustic blanket (Task 2-210).
 Remove electrical power (Task 1-37).

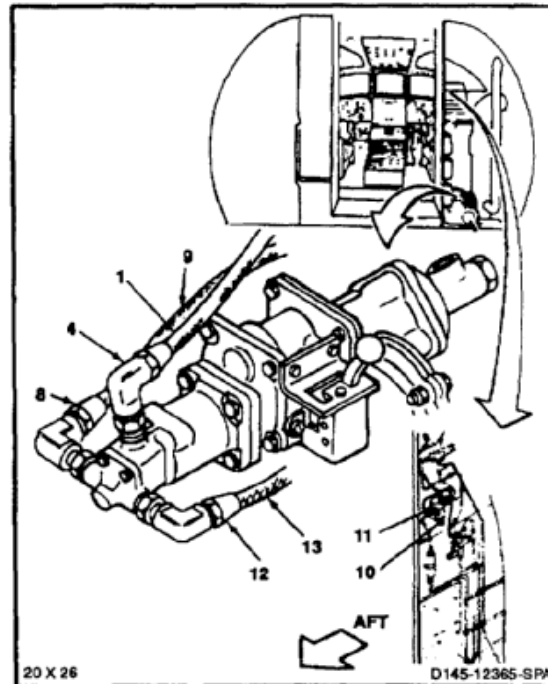

END OF TASK

7-1228

INITIAL SETUP

Applicable Configurations:

All

Tools:

- Hydraulic Repairer's Tool Kit, NSN 5180-00-323-4891
- Hydraulic Test Stand
- Filter Assembly Kit ADHT6814-M9716M

Materials:

- Cloths (E120)
- Hydraulic Fluid (E199)
- Gloves (E186)

Personnel Required:

Aircraft Pneudraulics Repairer (2)

Equipment Condition:

- Battery Connected (Task 1-39)
- Electrical Power On
- Hydraulic Power Off
- Hydraulic Test Stands Connected to Flight and Utility System Ground Service Panel (Task 1-38)
- Right Forward Work Platform or Pylon Right Access Door Open (Task 2-2)

No. 1 or No. 2 Flight Control Reservoir/Cooler Service (Task 1-60 or 1-61)
 Hydraulic Panel POWER XFER NO. 1 Switch Set to ON (TM 55-1520-240-T)

General Safety Instructions:

WARNING

Hydraulic fluid (E199) is toxic. It can irritate skin and cause burns. Avoid inhaling. Use only with adequate ventilation. Avoid contact with skin, eyes, or clothing. In case of contact, immediately flush skin or eyes with water for at least **15 minutes**. Get medical attention for eyes.

WARNING

Hydraulic fluid ejected under pressure can cause injury to personnel. Hydraulic fluid sprayed into the air is a fire hazard.

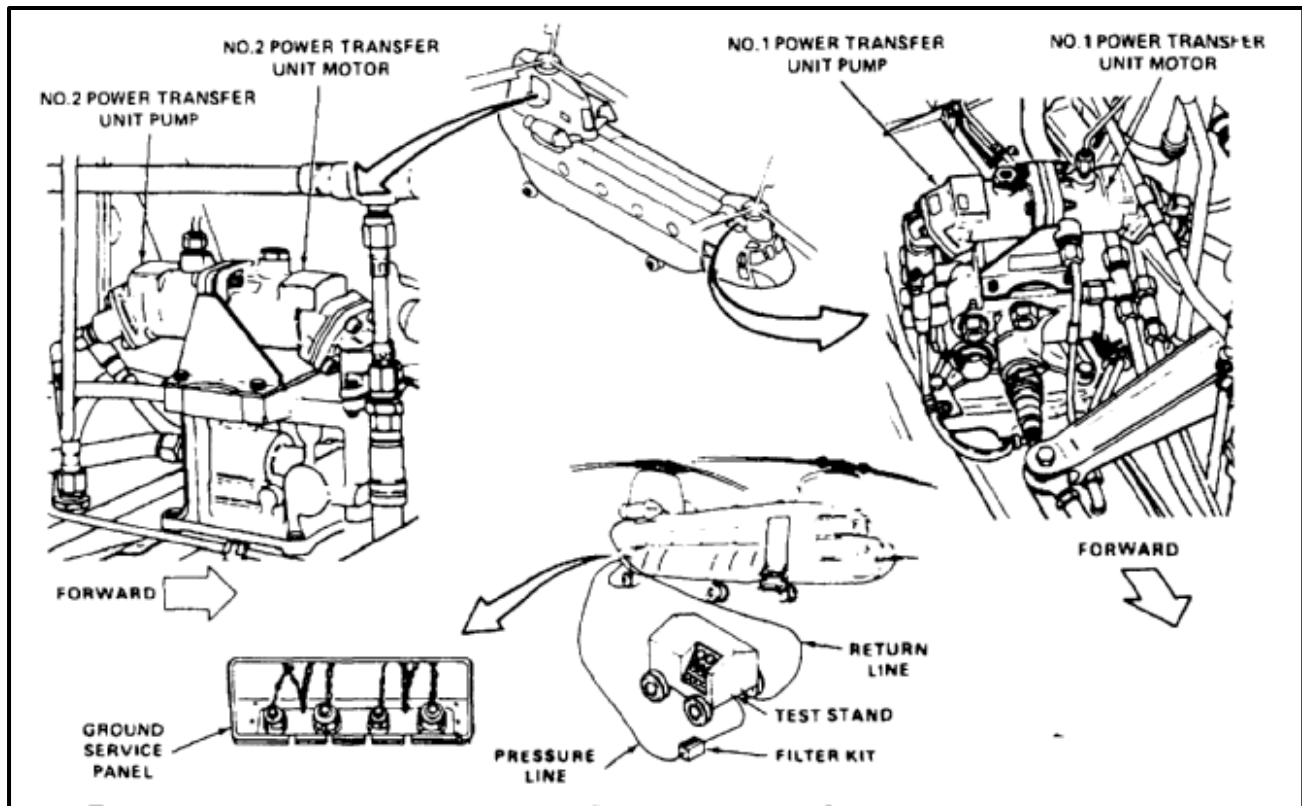



Filter assembly kit ADHT6814-M9716M must be installed in test stand pressure lines. Otherwise, system can be contaminated.

NOTE

To operate hydraulic test stand, refer to applicable manual.

NOTE

Procedure is same to bleed No. 1 or No. 2 PTU motor and pump. No. 1 motor and pump is shown here.

1. Remove plug (1) from port (2) of No. 1 PTU motor (3).
2. Fill pump (3) through port (2) with fluid (E199). Use cloths (E120) for spilled fluid.
3. Install plug (1) in port (2).
4. Disconnect drain tube (4) from port (5) of pump (6).
5. Fill motor (6) through port (5) with fluid (E199). Use cloths (E120) for spilled fluid. Use gloves (E186).
6. Connect tube (4) to port (5).
7. Apply hydraulic power to flight system. Set test stand to **300 psi**.
8. Apply hydraulic power to utility system. Slowly increase pressure until motor (3) rotates. Have helper on forward right work platform listen for motor rotation. Allow pump to rotate for about **3 minutes**.
9. Remove hydraulic power from flight and utility systems.

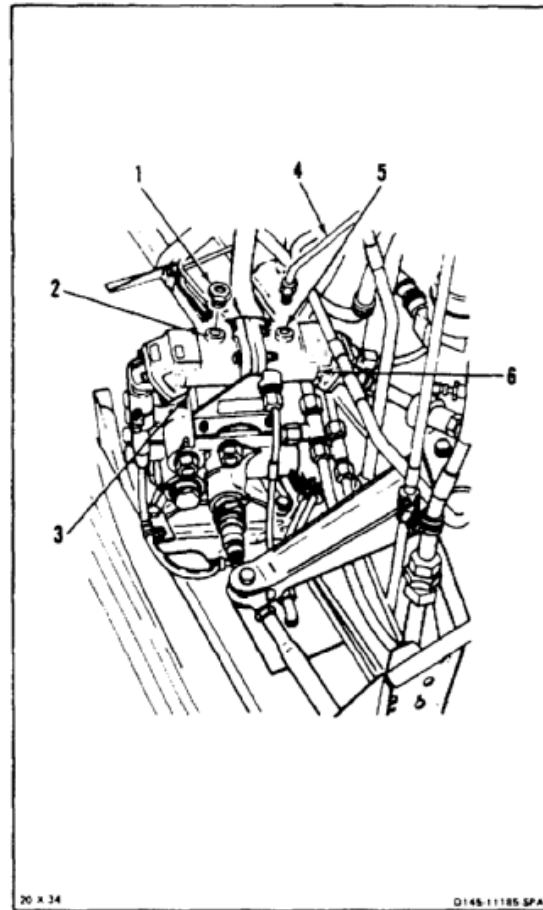

FOLLOW-ON MAINTENANCE:

- Set POWER XFER NO. 1 switch on hydraulic panel to OFF.
- Disconnect hydraulic test stands from ground service panel (Task 1-38).
- Remove electrical power (Task 1-37).
- Close right forward work platform or pylon right access door (Task 2-2).

END OF TASK

7-1230

INITIAL SETUP

Applicable Configurations:

All

Tools:

Hydraulic Repairer's Tool Kit, NSN 5180-00-323-4891
Containers

Materials:

Cloths (E120)
Gloves (E186)

Personnel Required:

Aircraft Pneudraulics Repairer

Equipment Condition:

Battery Disconnected (Task 1-39)
Electrical Power Off
Hydraulic Power Off
Right Pylon Access Door Open (Task 2-2)
Utility Reservoir Service (Task 1-62)

General Safety Instructions:**WARNING**

Hydraulic fluid (E199) is toxic. It can irritate skin and cause burns. Avoid inhaling. Use only with adequate ventilation. Avoid contact with skin, eyes, or clothing. In case of contact, immediately flush skin or eyes with water for at least **15 minutes**. Get medical attention for eyes.

WARNING

Hydraulic fluid ejected under pressure can cause injury to personnel. Hydraulic fluid sprayed into the air is a fire hazard.

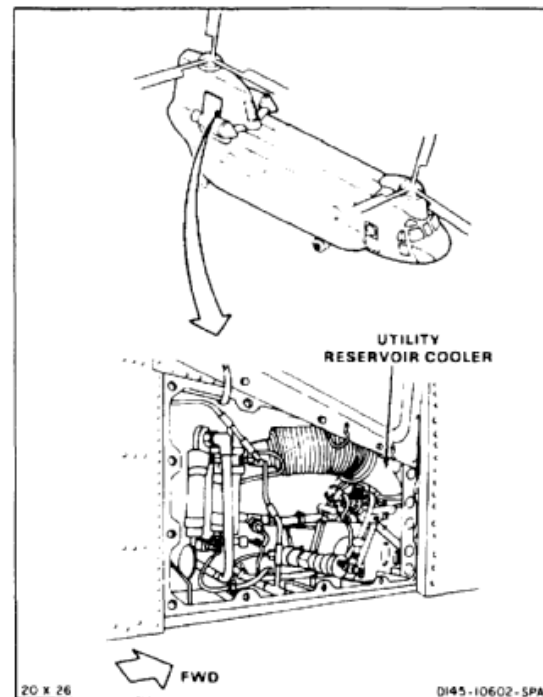

1. Open bleed valve (1) on utility reservoir/cooler (2) until fluid flowing from overboard drain (3) is air-free. Use container and cloths (E120) for spilled fluid. Use gloves (E186).
2. Close valve (1).

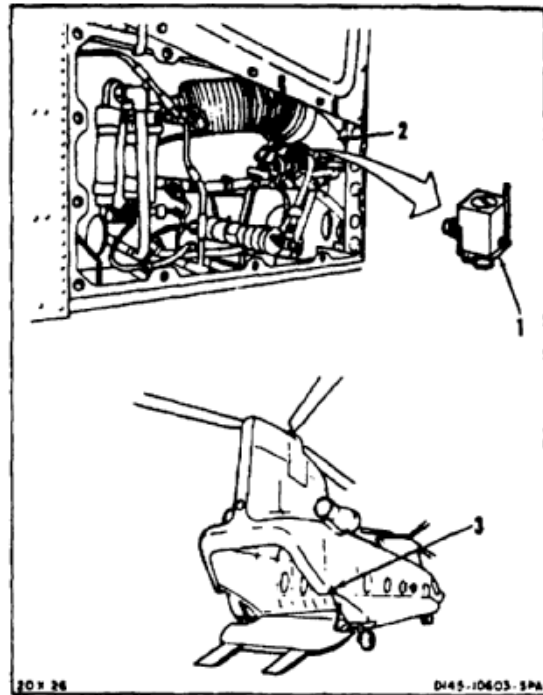
**FOLLOW-ON MAINTENANCE:**

Close right pylon access door (Task 2-2).

END OF TASK

7-1232

7-336 BLEED UTILITY HYDRAULIC RESERVOIR/COOLER, APU PUMP/ MOTOR AND UTILITY PUMP SYSTEM 7-336

INITIAL SETUP

Applicable Configurations:

All

Tools:

- Hydraulic Repairer's Tool Kit, NSN 5180-00-323-4891
- Container, 2 Quart
- Workstand
- Hydraulic Test Stand
- Tiedown Lines (2)

Materials:

- Cloths (E120)
- Hydraulic Fluid (E199)
- Gloves (E186)

Personnel Required:

Aircraft Pneudraulics Repairer (2)

Equipment Condition:

- Battery Connected (Task 1-39)
- Electrical Power On
- Hydraulic Power Off
- Cargo Ramp Open and Level (TM 55-1520-240-T)
- APU Start Accumulator Serviced (Task 1-64)
- Disconnect Engine Igniter (TM 55-2840-254-23)

- Repressurize Utility Hydraulic System (Task 7-135.1)
- Right Pylon Access Door Open (Task 2-2)
- Ground Service Panel Access Cover Open (Task 2-2)
- Aft Transmission Baffles Open (Task 2-2)
- Aft Transmission Drip Pan Removed (Task 2-3)
- APU Drip Pan Removed (Task 2-3)

General Safety Instructions:

WARNING

Hydraulic fluid (E99) is toxic. It can irritate skin and cause burns. Avoid inhaling. Use only with adequate ventilation. Avoid contact with skin, eyes, or clothing. In case of contact, immediately flush skin or eyes with water for at least **15 minutes**. Get medical attention for eyes.

WARNING

Hydraulic fluid ejected under pressure can cause injury to personnel. Hydraulic fluid sprayed into the air is a fire hazard.

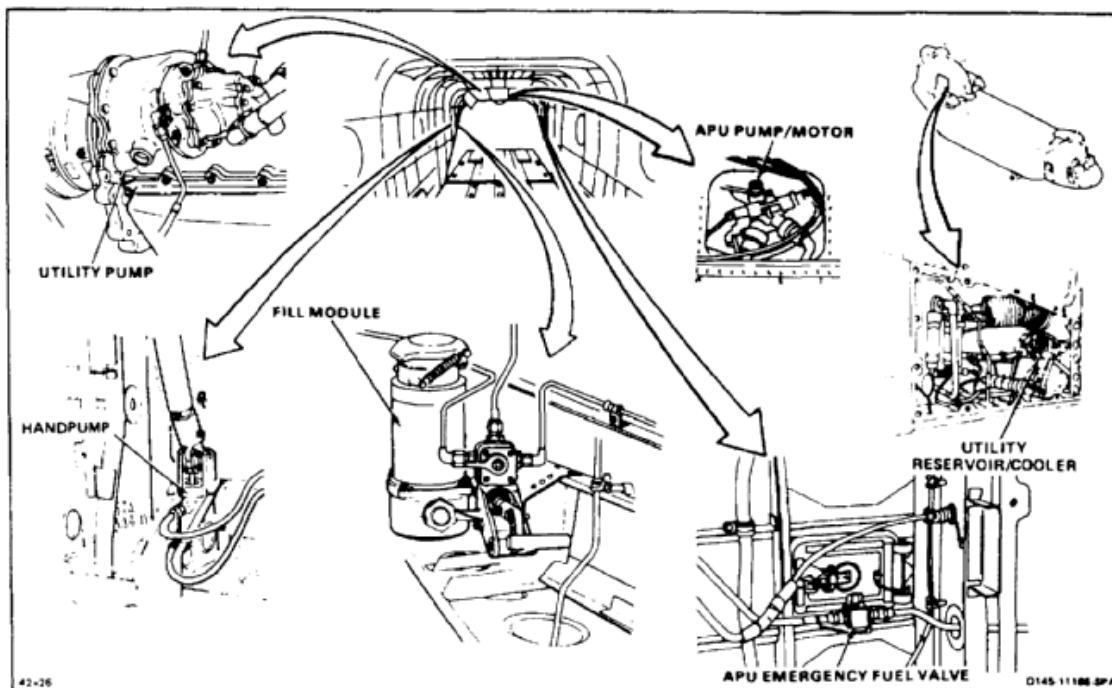

CAUTION

Filter assembly kit ADHT6814-M9716M must be installed in test stand pressure lines.

NOTE

To operate hydraulic test stand refer to applicable manual.

1. Open cap (1) of fill module (2). Fill module with hydraulic fluid (E199). Close cap.
2. Set handle (3) of selector valve (4) to position 3. Operate pump handle (5) until utility reservoir/cooler indicator (6) indicates full.
3. Working right of pylon, loosen clamp (7) and disconnect hose (8) from bleed valve (9) of utility reservoir/cooler (10).
4. Connect bleed hose (11) to valve (9).
5. Open valve (9) until fluid flow is air free. Use container and cloths (E120) for spilled fluid. Use gloves (E186).
6. Repeat steps 1 and 2.
7. Loosen nut (12) of tube (13) to handpump (14). Allow fluid to flow until air free. Tighten nut. Use cloths (E120) for spilled fluid.
8. Repeat steps 1 and 2.

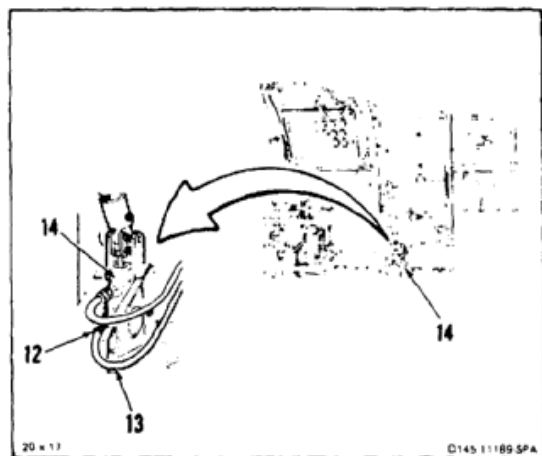
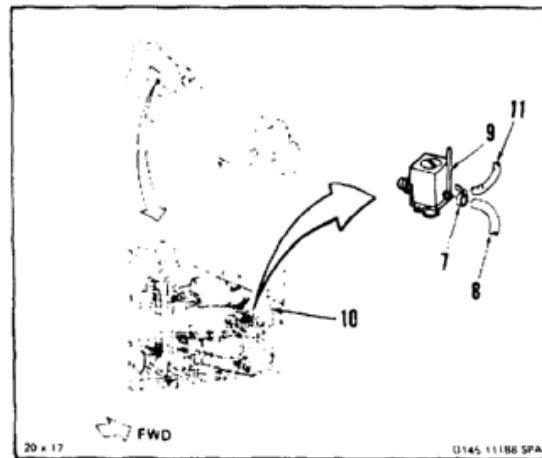
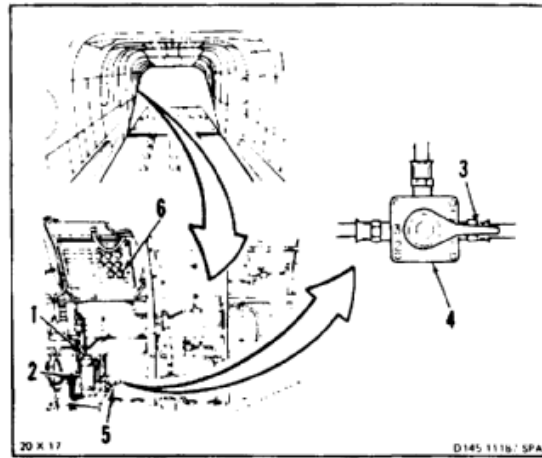

7-336 BLEED UTILITY HYDRAULIC RESERVOIR/COOLER, APU PUMP/MOTOR AND UTILITY PUMP SYSTEM (Continued)

9. Loosen nut (15) at SIG port (16) of APU motor/pump (17). Allow fluid to flow until air free. Tighten nut. Use cloths (E120) for spilled fluid.
10. Repeat steps 1 and 2.
11. Loosen nut (18) at LP port (19) of motor/pump (17). Allow fluid to flow until air free. Tighten nut. Use cloths (E120) for spilled fluid.
12. Repeat steps 1 and 2.

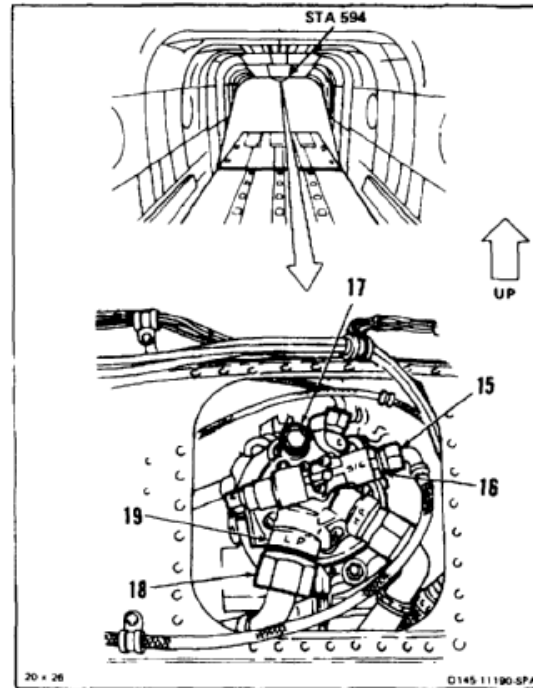

13. Loosen nut (20) at IN port (21) of utility pump (22). Allow fluid to flow until air free. Tighten nut. Use cloths (E120) for spilled fluid.
14. Repeat steps 1 and 2.
15. Loosen nut (23) of RETURN tube (24) to APU start accumulator manifold (25). Allow fluid to flow until air free. Tighten nut. Use cloths (E120) for spilled fluid.
16. Repeat steps 1 and 2.

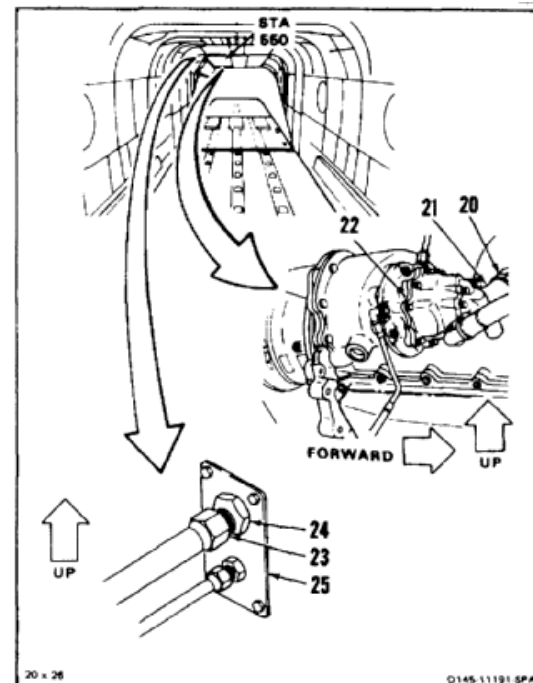

17. Working aft right of helicopter, remove two caps (26 and 27) from PRESSURE port (28) and RETURN port (29) of ground service panel (30).
18. Connect test stand pressure hose (31) to port (28) of panel (30).
19. Connect test stand return hose (32) to port (29) of panel (30).
20. Apply hydraulic power. Set stand to **300 psi**.

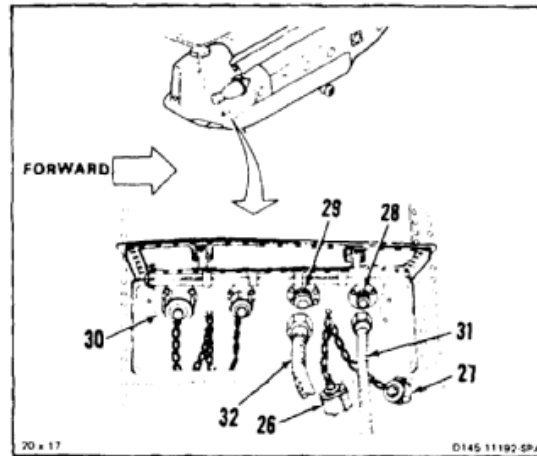

21. Working from ramp, loosen nut (33) of PRESSURE tube (34) to manifold (25). Allow fluid to flow until air free. Tighten nut. Use container and cloths (E120) for spilled fluid. Use gloves (E186).

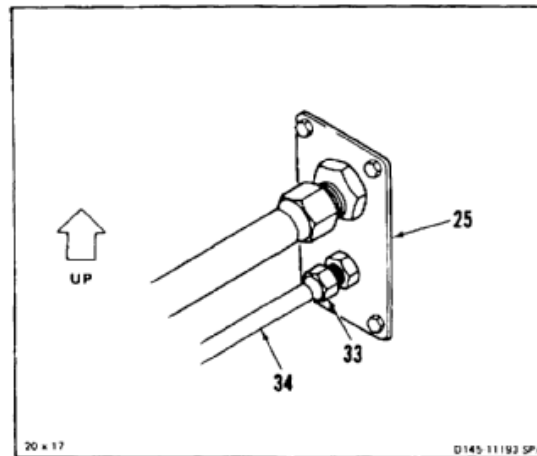

22. Working at right pylon, loosen nut (34) of pressure tube (35) to reservoir/cooler (10). Allow fluid to flow until air free. Tighten nut. Use cloths (E120) for spilled fluid.

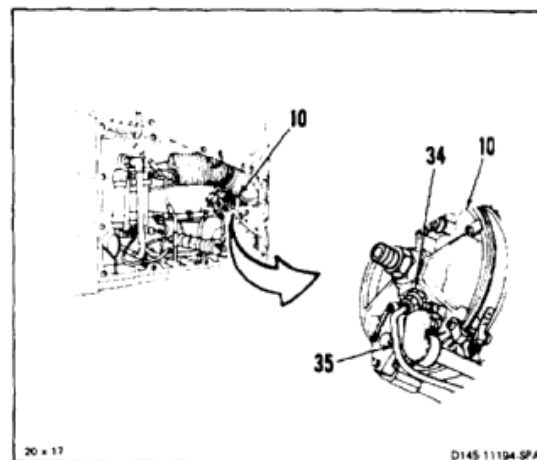

7-336 BLEED UTILITY HYDRAULIC RESERVOIR/COOLER, APU PUMP/ MOTOR AND UTILITY PUMP SYSTEM (Continued)

- 23. Working from ramp, disconnect CASE DRAIN hose (36) from motor/pump (17).
- 24. Fill motor/pump (17) through port (37) with hydraulic fluid (E199).
- 25. Connect hose (36) to port (37).

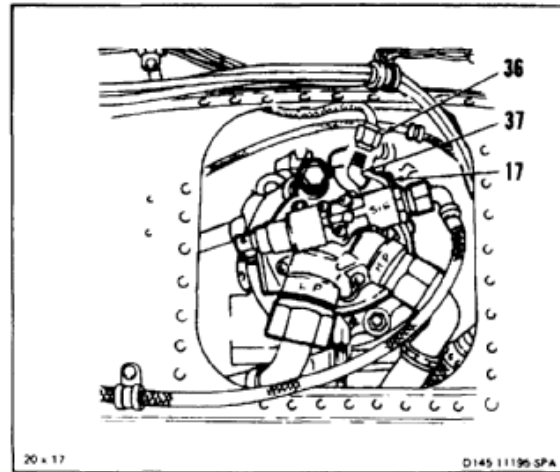

- 26. Close APU emergency fuel valve (38).

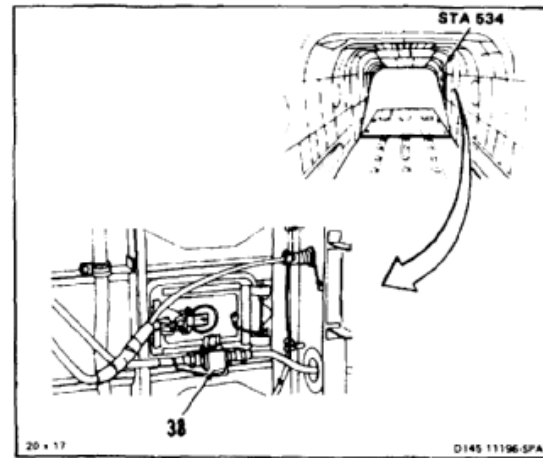

- 27. Working in cockpit, set APU switch (39) on ELECT panel (40) to START.

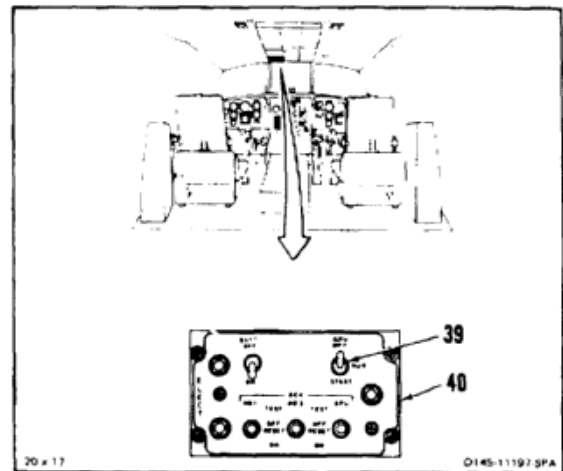

28. Have helper operate hand pump (14).

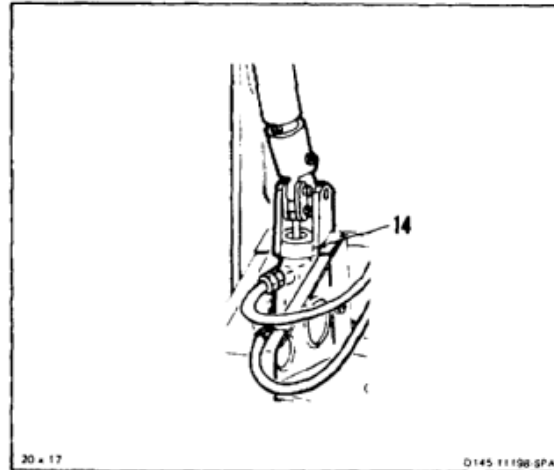

29. Listen for APU motor/pump (17) to rotate. While motor/pump is rotating, loosen nut (41) of case drain tube (42) of return control module (43). Allow fluid to flow until air free. Tighten nut. Use cloths (E120) for spilled fluid.

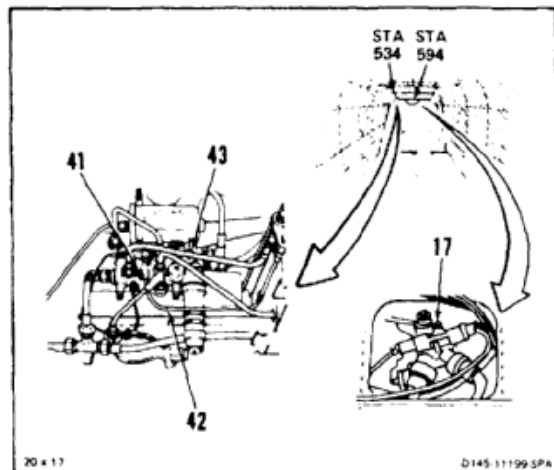

30. Stop operating pump (14).

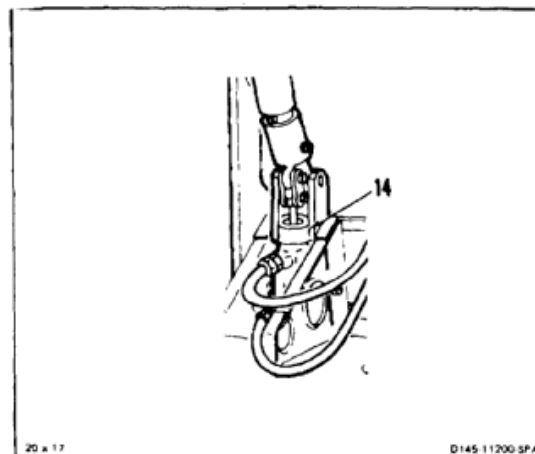

7-336 BLEED UTILITY HYDRAULIC RESERVOIR/COOLER, APU PUMP/MOTOR AND UTILITY PUMP SYSTEM (Continued)

31. Open valve (38).

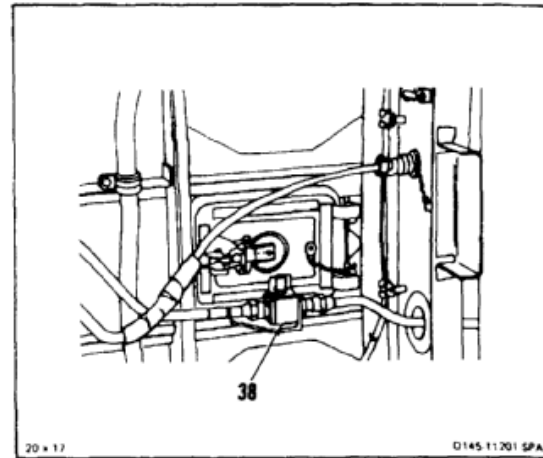

32. Working in cockpit, set switch (39) of panel (40) to OFF.

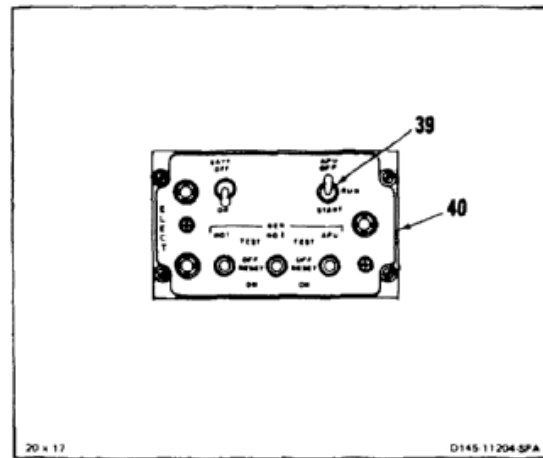

33. Set stand to **3000 psi**.

34. Loosen nut (41) of tube (42). Use container and cloths (E120) for spilled fluid. Use gloves (E186).

35. Rotate aft rotor head clockwise a minimum of **10 complete turns**, or until fluid flow from tube (42) is air free. Tighten nut (41). Use tiedown lines to turn rotor head.

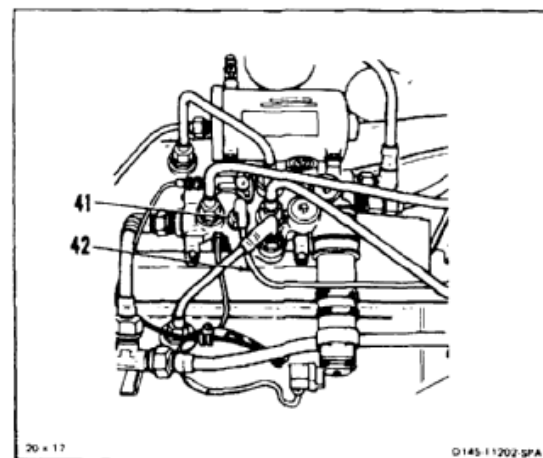

36. Working right of pylon, open valve (9) until fluid flow from hose (11) is air free. Use container and cloths (E120) for spilled fluid. Use gloves (E186).
37. Remove hose (11) from valve (9).
38. Slide clamp (7) on hose (8). Connect hose to valve (9). Tighten clamp.
39. Remove hydraulic power.

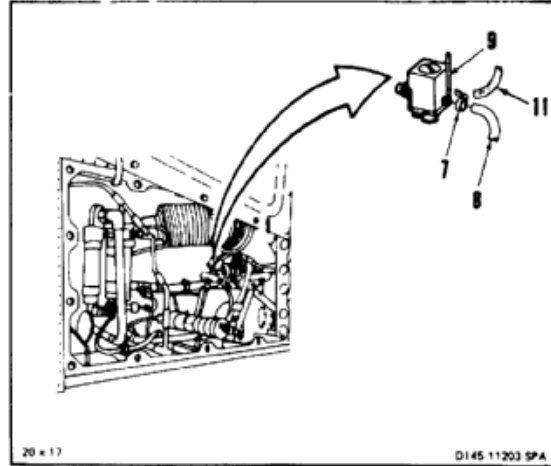

40. Working aft right of helicopter, disconnect two hoses (31 and 32) from panel (30). Use cloths (E120) for spilled fluid. Use gloves (E186).
41. Install two caps (26 and 27) on ports (28 and 29) of panel (30).

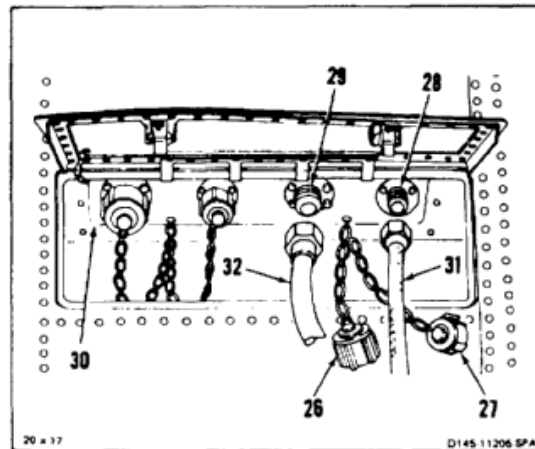

FOLLOW-ON MAINTENANCE:

- Remove electrical power (Task 1-37).
- Close pylon right access door (Task 2-2).
- Close ground service panel access cover (Task 2-2).
- Install aft transmission drip pan (Task 2-3).
- Install APU drip pan (Task 2-3).
- Close aft transmission access panels (Task 2-2).
- Close cargo ramp (TM 55-1520-240-T).

END OF TASK

7-1240

INITIAL SETUP

Applicable Configurations:

All

Tools:

Hydraulic Repairer's Tool Kit, NSN 5180-00-323-4891
Container, 2 Quart

Materials:

Cloths (E120)
Gloves (E186)

Personnel Required:

Aircraft Pneudraulics Repairer (2)

Equipment Condition:

Battery Connected (Task 1-39)
Electrical Power On
Hydraulic Power On
Cargo Hook Actuator Serviced (Task 1-74)
Hydraulic Test Stand Connected to Ground Service
Panel (Task 1-38)
Rescue Hatch Open (Task 2-2)

General Safety Instructions:**WARNING**

Hydraulic fluid (E199) is toxic. It can irritate skin and cause burns. Avoid inhaling. Use only with adequate ventilation. Avoid contact with skin, eyes, or clothing. In case of contact, immediately flush skin or eyes with water for at least **15 minutes**. Get medical attention for eyes.

WARNING

Hydraulic fluid ejected under pressure can cause injury to personnel. Hydraulic fluid sprayed into the air is a fire hazard.

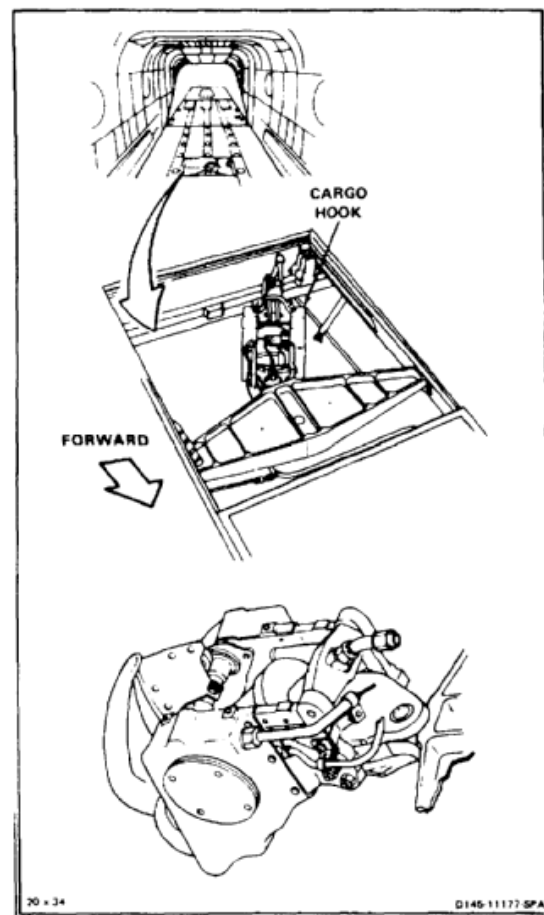

CAUTION

Filter assembly kit ADHT6814-M9716M must be installed in test stand pressure line. Otherwise, system can be contaminated.

NOTE

To operate hydraulic test stand, refer to applicable manual.

1. Have helper support hook (1). Release stowage strap (2).
2. Lower hook (1) until it hangs free.
3. Apply hydraulic power. Set test stand to **200 psi**.
4. Loosen nut (3) of pressure hose (4). Allow fluid to flow until air free. Tighten nut. Use container and cloths (E120) for spilled fluid. Use gloves (E186).
5. Set stand to **1000 psi**.

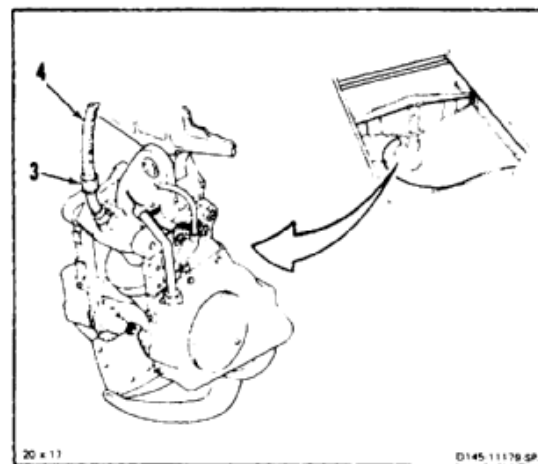
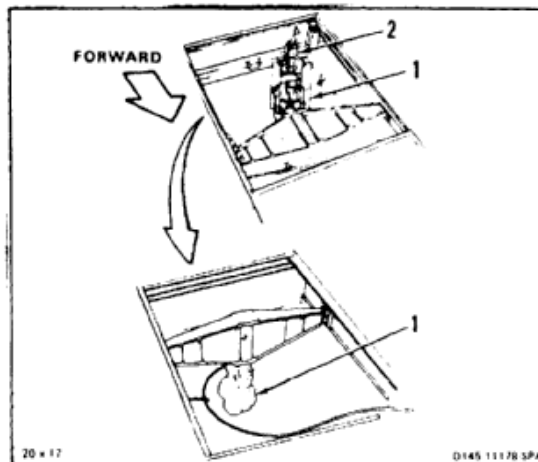

6. Working in cockpit, set HOOK SELECT switch (5) to MID on CARGO HOOK panel (6).
7. Set MASTER switch (7) to ARM.
8. Press and release CARGO HOOK RELEASE switch (8) on pilot's or copilot's control stick (9). Check cargo hook opens.
9. Set switch (7) to RESET. Check cargo hook closes.
10. Repeat steps 7, 8, and 9 **five times**.
11. Repeat step 4.
12. Set switch (7) to OFF.
13. Remove hydraulic power.

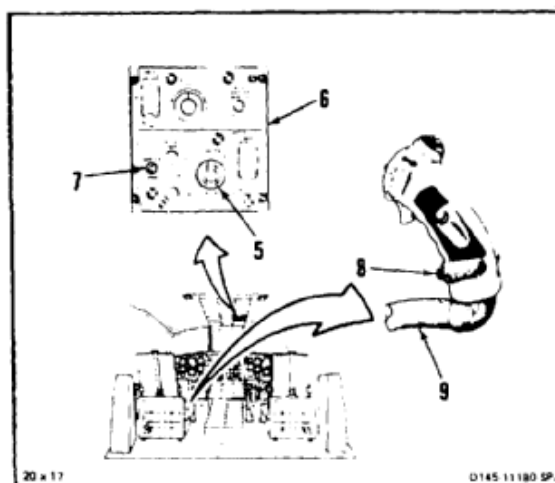

14. Have helper lift cargo hook (1) to stowed position. Slide stowage strap (2) through hook (10) and tighten strap.

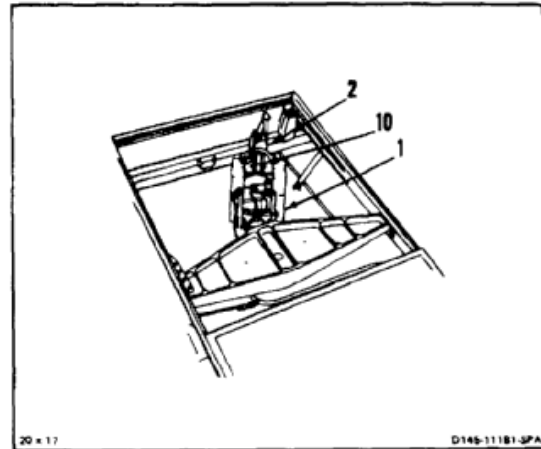

FOLLOW-ON MAINTENANCE:

- Close rescue hatch (Task 2-2).
- Disconnect hydraulic test stand (Task 1-38).
- Electrical power off.

END OF TASK

INITIAL SETUP

Applicable Configurations:

Without **74**

Tools:

- Hydraulic Repairer's Tool Kit, NSN 5780-00-323-4891
- Hydraulic Test Stand
- Filter Assembly Kit ADHT 6814-M9716M
- Container
- Reducers, MS21916012-10

Materials:

- Cloths (E120)
- Gloves (E184.1)

Personnel Required:

- Aircraft Pneudraulics Repairer
- Inspector

Equipment Condition:

- Battery Connected (Task 1-39)
- Electrical Power On

- Hydraulic Power Off
- Hydraulic Connection Access Panel Open (Task 2-2)
- Engine Access Covers Open (Task 4-49)

General Safety Instructions:

WARNING

Hydraulic fluid (E199) is toxic. It can irritate skin and cause burns. Avoid inhaling. Use only with adequate ventilation. Avoid contact with skin, eyes, or clothing. In case of contact, immediately flush skin or eyes with water for at least **15 minutes**. Get medical attention for eyes.

WARNING

Hydraulic fluid ejected under pressure can cause injury to personnel. Hydraulic fluid sprayed into the air is a fire hazard.

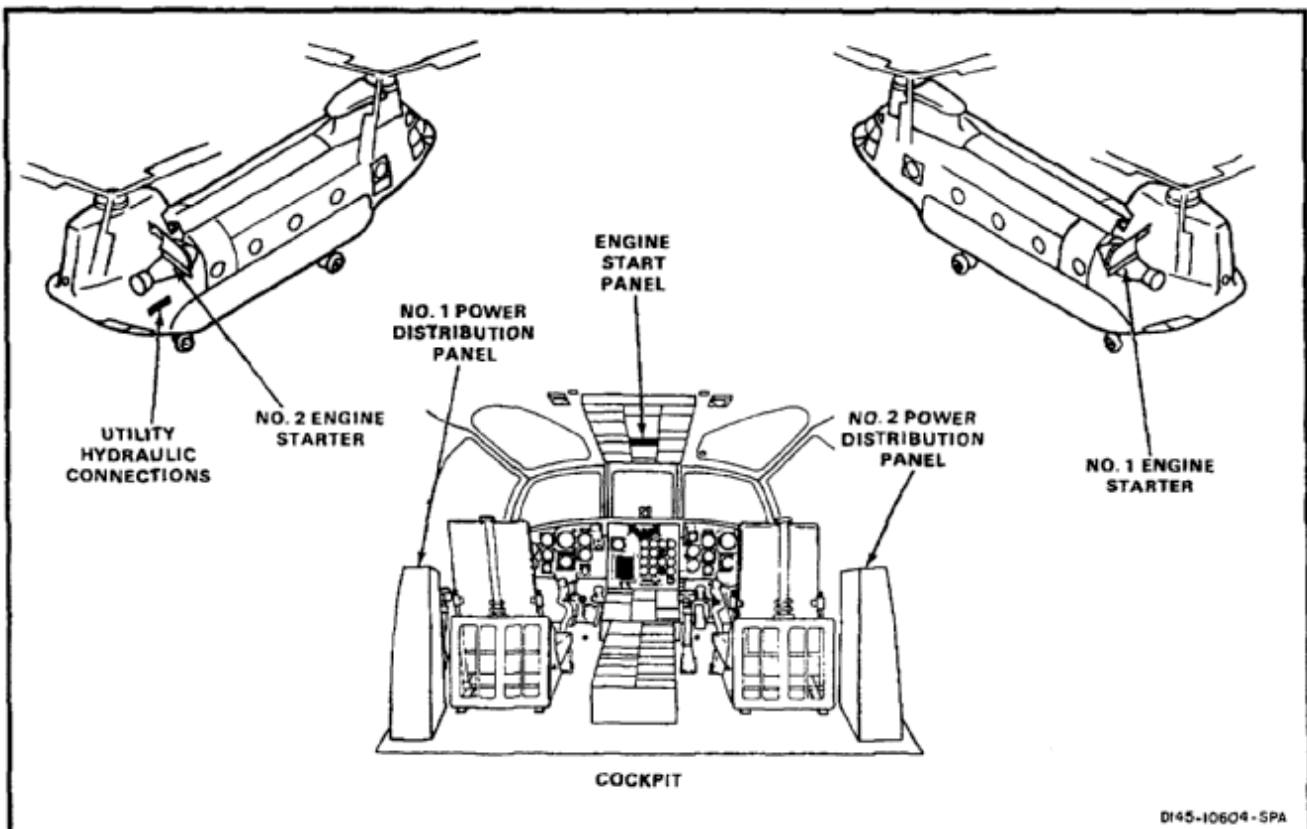

NOTE

Test stand filters must be cleaned before connecting test stand to helicopter.

Make sure filter assembly kit ADHT6814-M9716M is installed in test stand pressure line.

To operate hydraulic test stand, refer to applicable manual.

1. In cockpit, place ENGINE 1 start switch (1) and ENGINE 2 start switch (2) on START panel (3) to OFF position.
2. Pull out ENGINE No. 1 IGN circuit breaker (4) on No. 1 POP (5) to OFF position.
3. Pull out ENGINE No. 2 IGN circuit breaker (5) on No. 2 PDP (7) to OFF position.

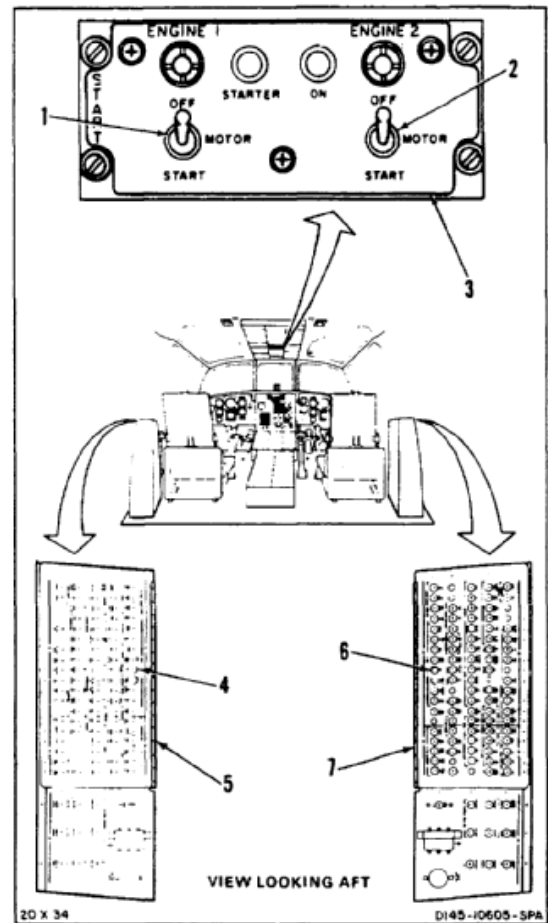

4. Remove dust cover (8) from PRESSURE connection (9) and dust cover (10) from SUCTION connection (11).
5. Connect test stand pressure line (12) to PRESSURE connection (9) and test stand return line (13) to SUCTION connection (11). Open shutoff valve in test stand return line.

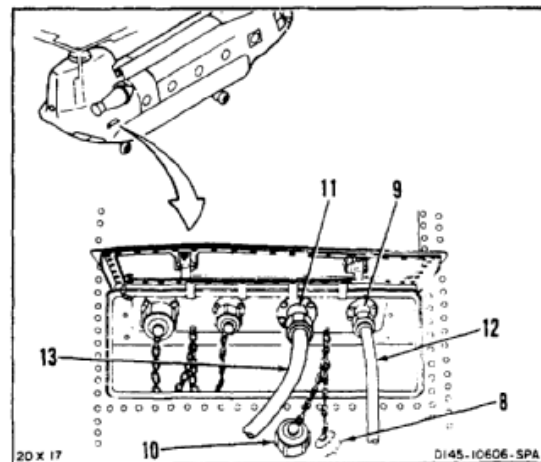

NO. 1 ENGINE

6. Disconnect pressure line (14) and return line (15) from engine starter (16). Use gloves (E186).
7. Connect pressure line (14) to return line (15) with reducer.
8. Start hydraulic test stand and adjust pressure to **500 psi**.
9. In cockpit, set ENGINE 1 start switch (1) on cockpit START panel (3) to MOTOR. After **5 minutes** set switch (1) to OFF. Shut down test stand.
10. At engine, disconnect pressure line (14) from return line (15).
11. Connect pressure line (14) and return line (15) to engine starter (16).
12. Start hydraulic test stand. Set switch (1) to MOTOR. Increase stand pressure until engine starts to rotate. After engine has rotated slowly for **2 minutes**, set switch (1) to OFF. Shut down test stand.

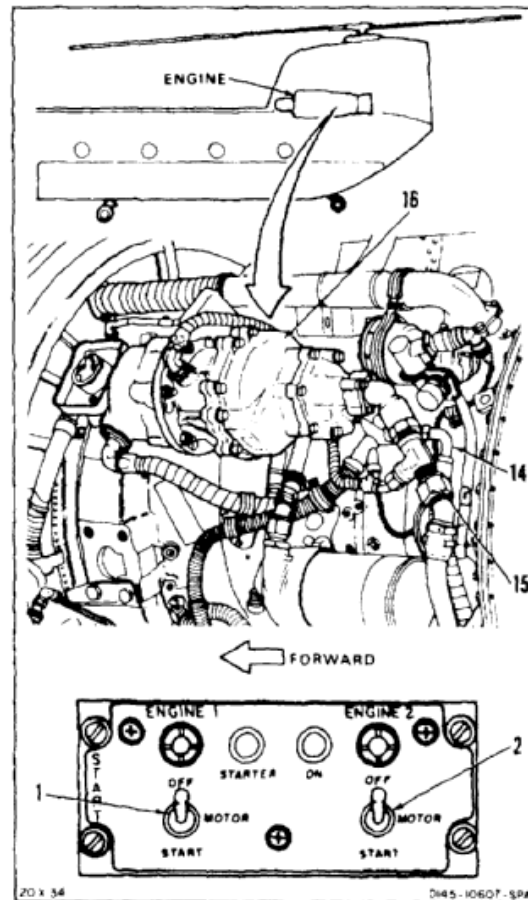
**INSPECT****NO. 2 ENGINE**

13. For No. 2 engine, repeat steps 6 thru 8.
14. Set ENGINE 2 start switch (2) on cockpit START panel (3) to MOTOR. After **5 minutes** set switch (2) to OFF. Shut down test stand.
15. Repeat steps 10 and 11 for No. 2 engine.
16. Start hydraulic test stand. Set switch (2) to MOTOR. Increase stand pressure until engine starts to rotate. After engine has rotated slowly for **2 minutes** set switch (2) to OFF. Shut down test stand.

17. Remove test stand pressure line (12) from PRESSURE connection (9). Install dust cover (8) on PRESSURE connection. Use container and cloths (E120) for spilled fluid. Use gloves (E186).
18. Remove test stand return line (13) from SUCTION connection (11). Install dust cover (10) on SUCTION connection. Use container and cloths (E120) for spilled fluid. Use gloves (E186).

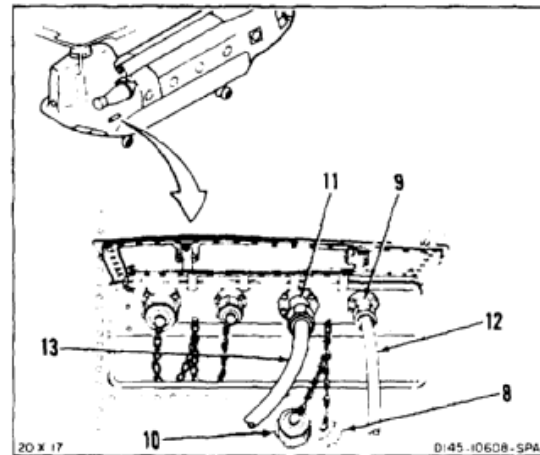
INSPECT**FOLLOW-ON MAINTENANCE:**

- Service utility reservoir (Task 1-59 or 1-62).
- Electrical power off.
- Close hydraulic connection access panel (Task 2-2).
- Close engine access covers (Task 4-50).

END OF TASK

INITIAL SETUP

Applicable Configurations:

With **74**

Tools:

- Hydraulic Repairer's Tool Kit, NSN 5780-00-323-4891
- Hydraulic Test Stand
- Container
- Reducers MS21916D12-10

Materials:

- Cloths (E120)
- Gloves (E184.1)

Personnel Required:

- Aircraft Pneudraulics Repairer
- Inspector

References:

- TM 55-4929-335-14 or
- TM 55-4920-373-14&P

Equipment Condition:

Battery Connected (Task 1-39)

- Electrical Power On
- Hydraulic Power Off
- Hydraulic Connection Access Panel Open (Task 2-2)
- Engine Access Covers Open (Task 4-49)

General Safety Instructions:

WARNING

Hydraulic fluid (E199) is toxic. It can irritate skin and cause burns. Avoid inhaling. Use only with adequate ventilation. Avoid contact with skin, eyes, or clothing. In case of contact, immediately flush skin or eyes with water for at least **15 minutes**. Get medical attention for eyes.

WARNING

Hydraulic fluid ejected under pressure can cause injury to personnel. Hydraulic fluid sprayed into the air is a fire hazard.

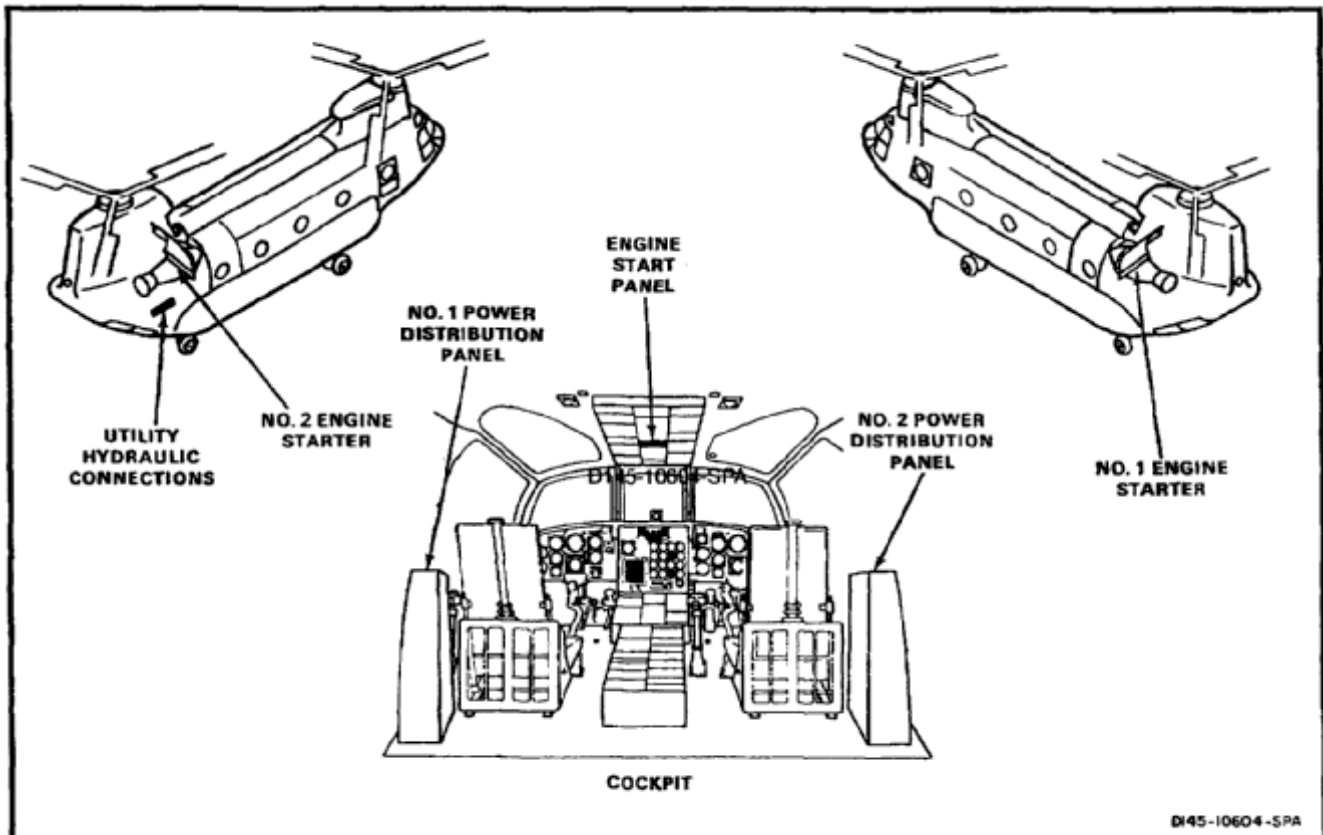

NOTE

Test stand filters must be cleaned before connecting test stand to helicopter.

To operate hydraulic test stand, refer to applicable manual.

1. In cockpit, place ENG START switch to center position between (1 and 2) on START panel (3).
2. Pull out ENGINE NO. 1 START & IGN circuit breaker (4) on No. 1 PDP (5) to OFF position.
3. Pull out ENGINE NO. 2 START & IGN circuit breaker (6) on No. 2 PDP (7) to OFF position.

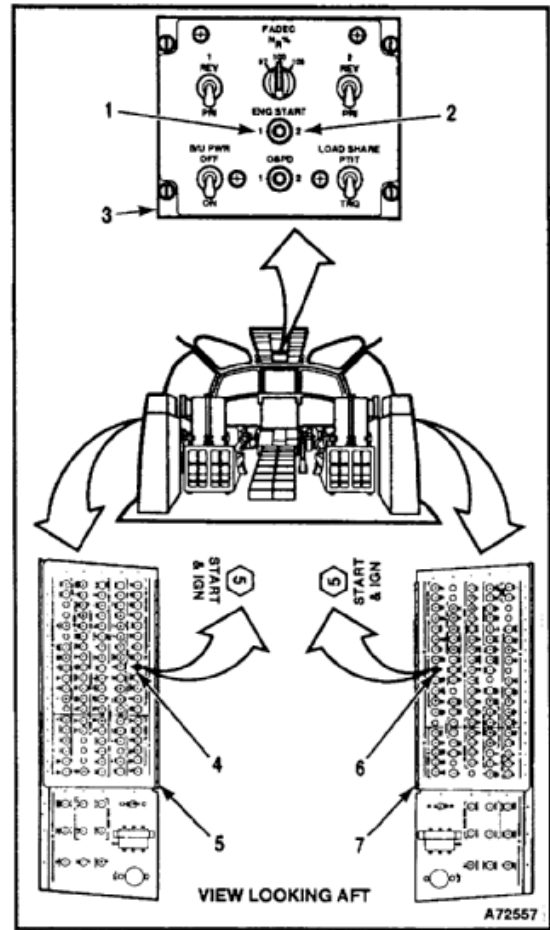

4. Remove dust cover (8) from PRESSURE connection (9) and dust cover (10) from SUCTION connection (11).
5. Connect test stand pressure line (12) to PRESSURE connection (9) and test stand return line (13) to SUCTION connection (11). Open shutoff valve in test stand return line.

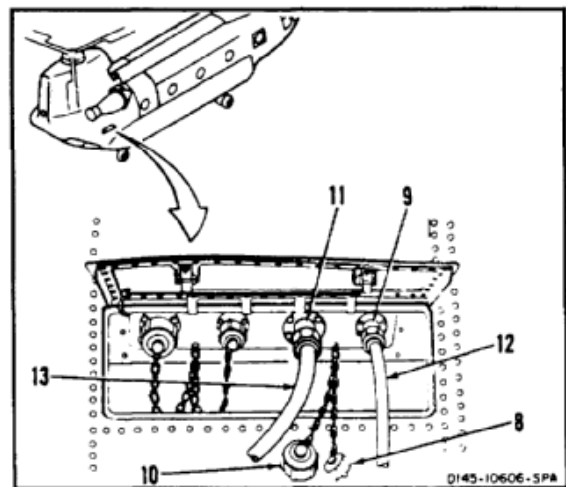

NO. 1 ENGINE

6. Disconnect pressure line (14) and return line (15) from engine starter (16). Wear gloves (E184.1).
7. Connect pressure line (14) to return line (15) with reducer.
8. Start hydraulic test stand and adjust pressure to **500 psi**.
9. In cockpit, set ENG START switch on cockpit FADEC panel (3) to position 1. After **5 minutes** set switch (1) to center position. Shut down test stand.
10. At engine, disconnect pressure line (14) from return line (15).
11. Connect pressure line (14) and return line (15) to engine starter (16).
12. Start hydraulic test stand. Set ENG START switch to position 1. Increase stand pressure until engine starts to rotate. After engine has rotated slowly for **2 minutes**, set switch to center position. Shut down test stand.

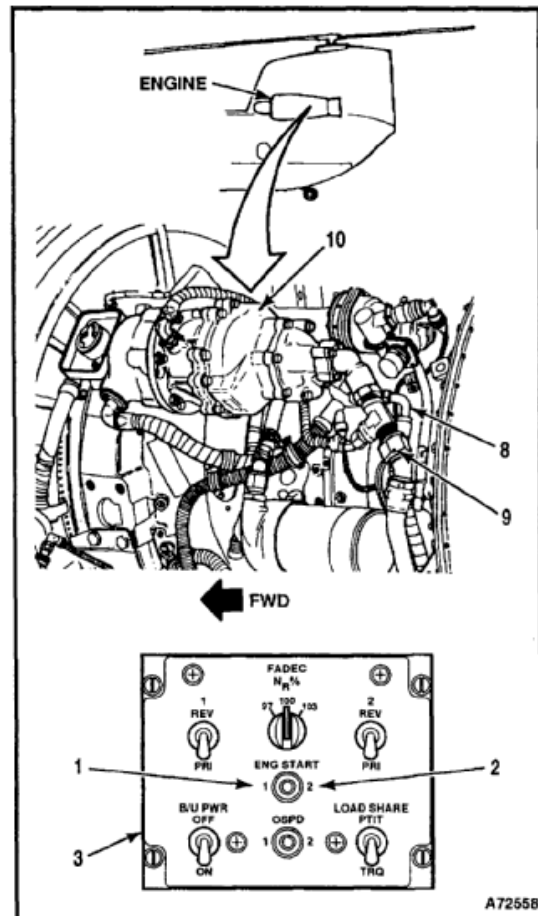
**INSPECT****NO. 2 ENGINE**

13. For No. 2 engine, repeat steps 6 thru 8.
14. Set ENG START switch on cockpit FADEC panel (3) to position 2. After **5 minutes** set switch to center position. Shut down test stand.
15. Repeat steps 10 and 11 for No. 2 engine.
16. Start hydraulic test stand. Set ENG START switch to position 2. Increase stand pressure until engine starts to rotate. After engine has rotated slowly for **2 minutes** set switch to center position. Shut down test stand.

17. Remove test stand pressure line (12) from PRESSURE connection (9). Install dust cover (8) on PRESSURE connection. Use container and cloths (E120) for spilled fluid. Wear gloves (E184.1).
18. Remove test stand return line (13) from SUCTION connection (11). Install dust cover (10) on SUCTION connection. Use container and cloths (E120) for spilled fluid. Wear gloves (E184.1).

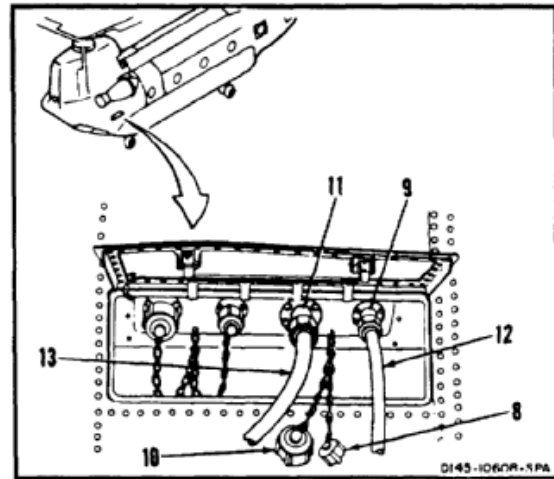
INSPECT**FOLLOW-ON MAINTENANCE:**

- Service utility reservoir (Task 1-59 or 1-62).
- Electrical power off.
- Close hydraulic connection access panel (Task 2-2).
- Close engine access covers (Task 4-50).

END OF TASK

INITIAL SETUP

Applicable Configurations:

All

Tools:

- Hydraulic Repairer's Tool Kit, NSN 5180-00-323-4891
- Hose
- Container, 14 Quart
- Workstand
- Hydraulic Test Stand
- Filter Assembly Kit ADHT6814-M9716M

Materials:

- Cloths (E120)
- Hydraulic Fluid (E199)
- Gloves (E186)

Personnel Required:

Aircraft Pneudraulics Repairer (2)

Equipment Condition:

- Battery Connected (Task 1-39)
- Electrical Power On
- Hydraulic Power Off
- Cargo Ramp Fully Down (TM 55-1520-240-T)
- Ramp Switch Set to ON (TM 55-1520-240-T)
- Hydraulic Test Stand Connected to Ground Service Panel (Task 1-38)

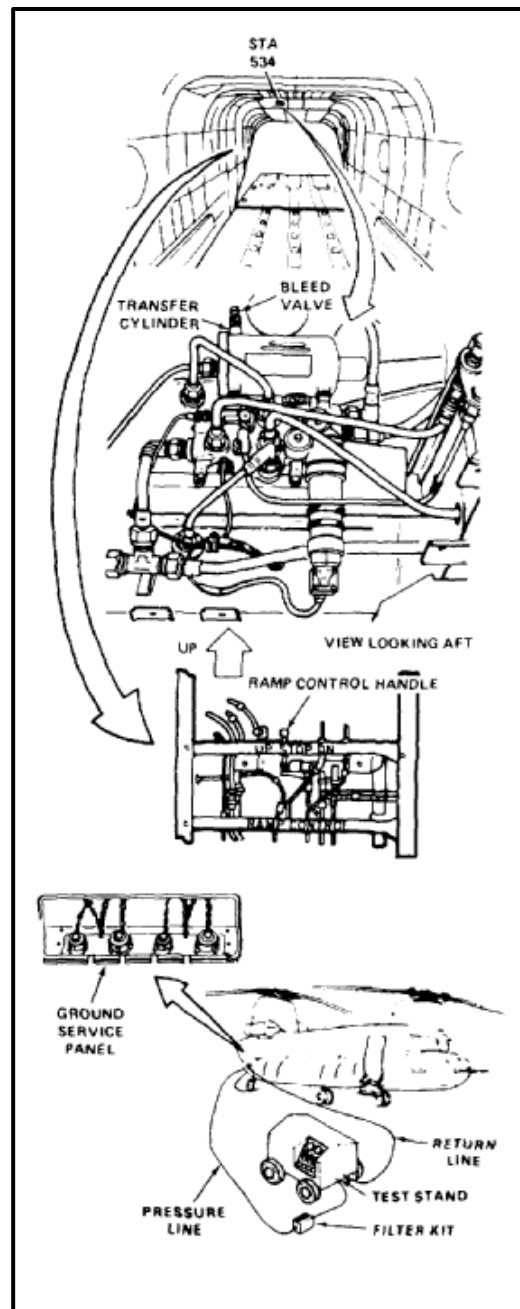

CAUTION

Filter assembly kit ADHT6814-M9716M must be installed in test stand pressure lines. Otherwise, system can be contaminated.

NOTE

To operate hydraulic test stand, refer to applicable manual.

1. Remove cap (1) from transfer cylinder bleed valve (2).
2. Connect bleed hose (3) to valve (2).

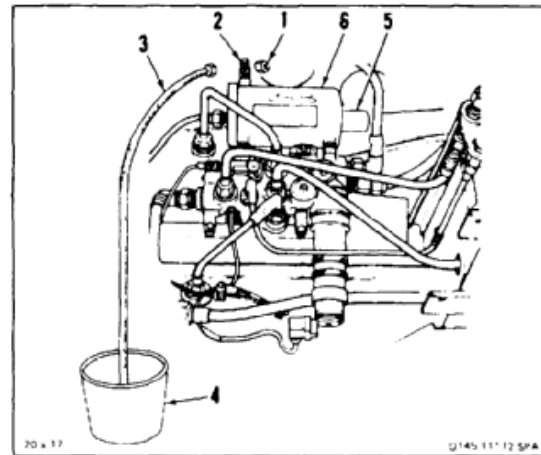
**CAUTION**

Container and hydraulic fluid (E199) must be clean; otherwise, components can malfunction.

3. Fill container (4) with about **one gallon** of hydraulic fluid (E199). Use gloves (E186).
4. Position open end of hose (3) below fluid level in container (4).
5. Open valve (2). Push piston rod (5) fully in transfer cylinder (6).

6. Position ramp control (7) to UP.
7. Apply hydraulic power. Increase test stand pressure until ramp starts to close. When ramp is about **1 inch** from fully closed, set control (7) to STOP.

NOTE

Bleed hose must be below fluid level during bleeding.

8. Set control (7) to DN. Lower ramp slowly by operating control between DN and STOP.

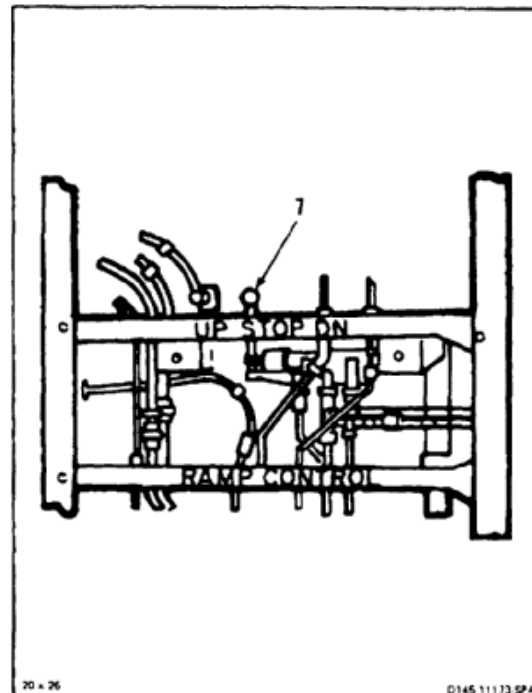

9. Repeat steps 6, 7, and 8 until fluid from hose (3) is air free.
10. Repeat step 8. Close valve (2).
11. Repeat step 6. Check rod (5) extends about **4.2 inches** from cylinder (6).
12. Repeat step 8. Check rod (5) retracts.
13. Disconnect hose (3) from valve (2). Use cloths (E120) for spilled fluid.
14. Install cap (1) on valve (2).
15. Remove hose (3) and container (4).

FOLLOW-ON MAINTENANCE:

Close cargo ramp (TM 55-1520-240-T).
 Disconnect hydraulic test stand from ground service panel (Task 1-38).
 Remove electrical power (Task 1-37).
 Set ramp switch to OFF.

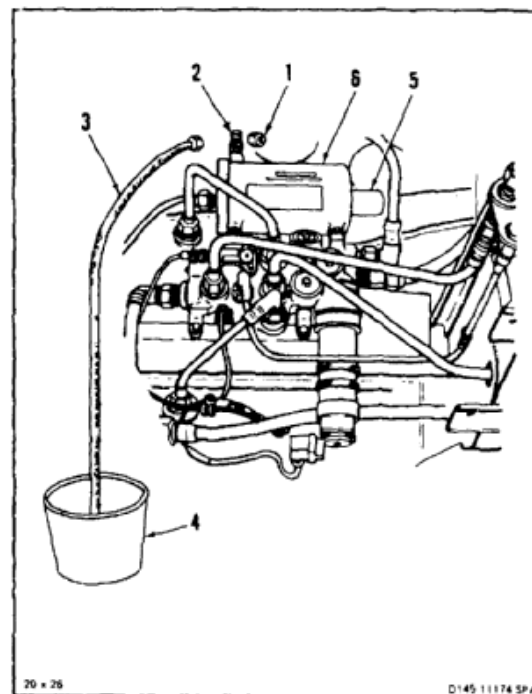

END OF TASK

7-1254

INITIAL SETUP

Applicable Configurations:

All

Tools:

Hydraulic Repairer's Tool Kit, NSN 5180-00-323-4891
 Container, 2 Quart (3)

Materials:

Cloths (E120)
 Paper Tags (E264)
 Gloves (E186)
 Bleed Hose (Tubing) (E428)

Personnel Required:

Aircraft Pneudraulics Repairer (2)
 Inspector

References:

Task 1-36

Equipment Condition:

Battery Connected (Task 1-39)
 Electrical Power Off

Hydraulic Power Off

Wheel Brake Accumulator Serviced (Task 1-67)

Forward Left Work Platform Open (Task 2-2)

Aft Landing Gear Access Panels Open (Task 2-2)

General Safety Instructions:

WARNING

Hydraulic fluid (E199) is toxic. It can irritate skin and cause burns. Avoid inhaling. Use only with adequate ventilation. Avoid contact with skin, eyes, or clothing. In case of contact, immediately flush skin or eyes with water for at least **15 minutes**. Get medical attention for eyes.

WARNING

Hydraulic fluid ejected under pressure can cause injury to personnel. Hydraulic fluid sprayed into the air is a fire hazard.

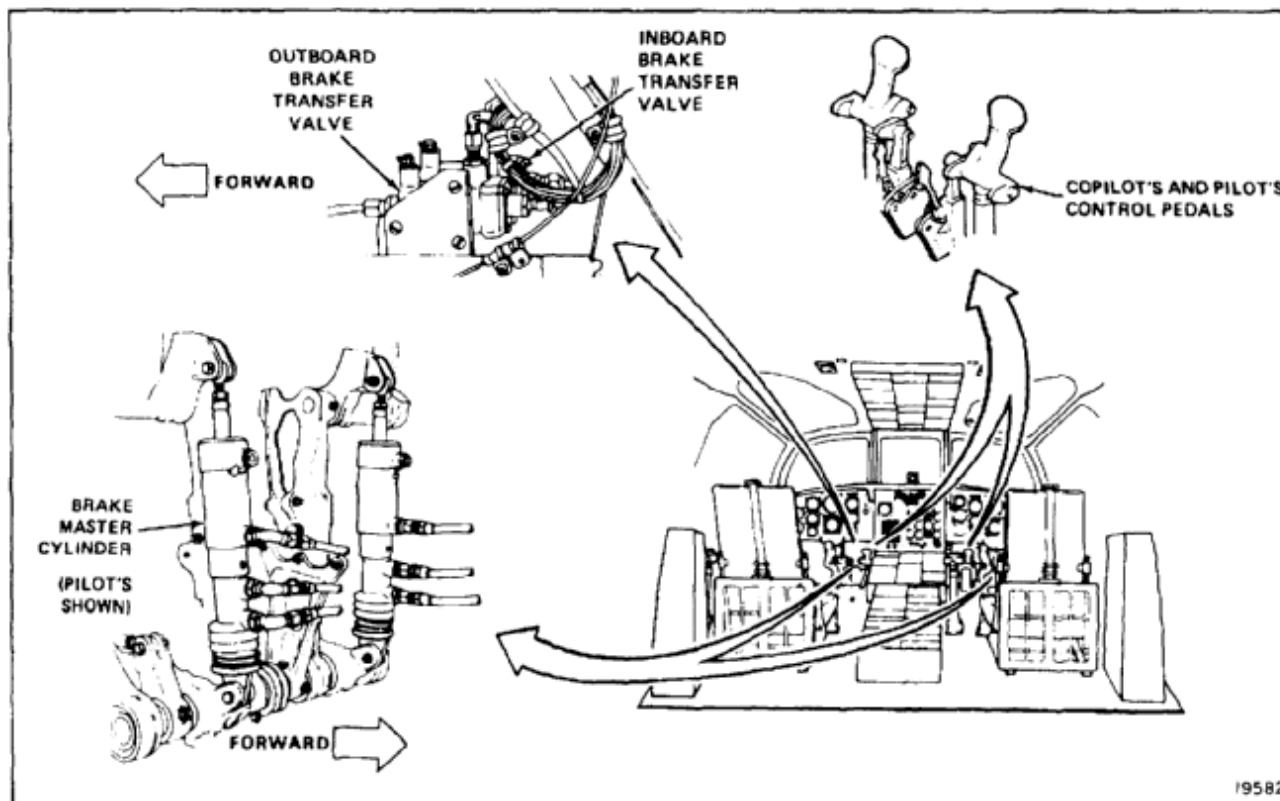

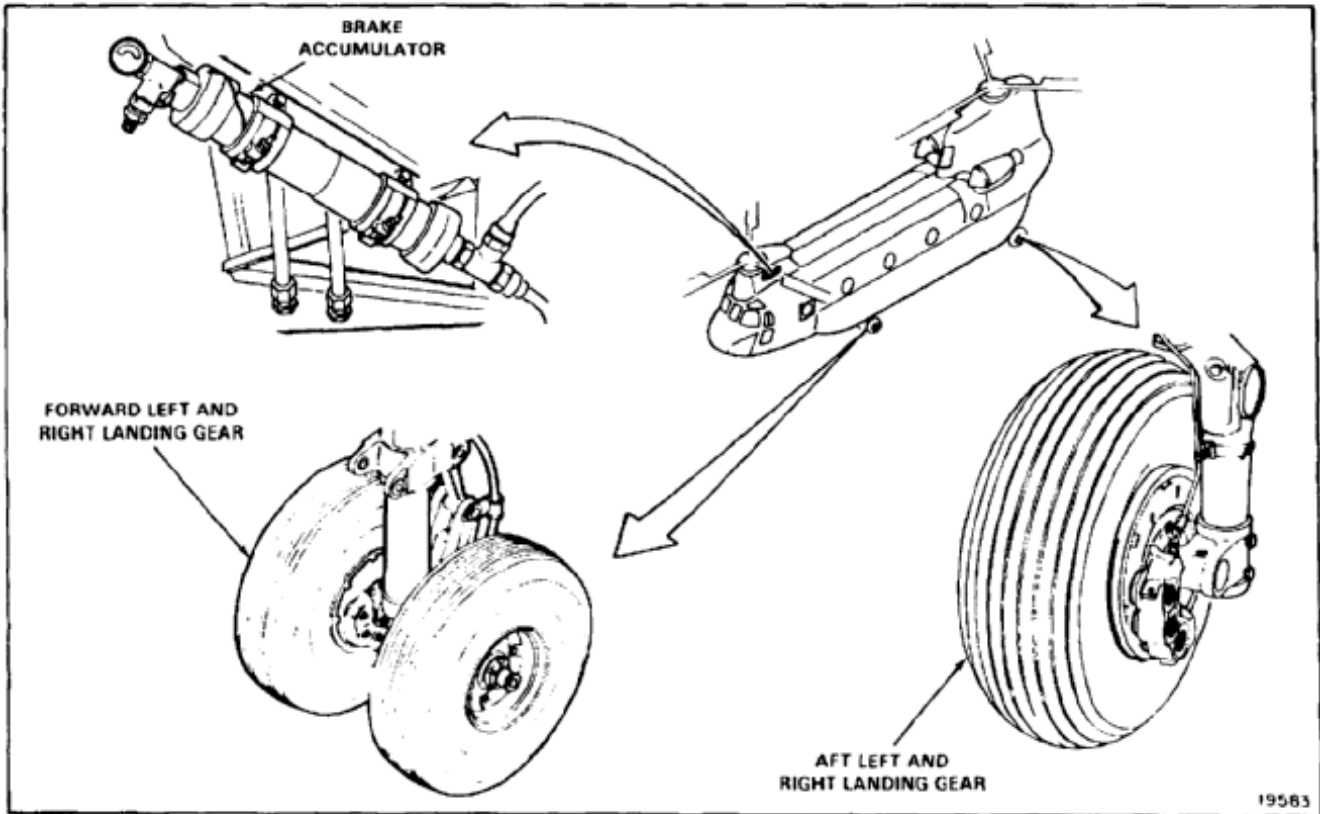

NOTE

Throughout this task, whenever a connection is loosened to let air escape from a hydraulic line, use a container and cloths (E120) to catch spilled fluid. Wear gloves (E186).

PILOT'S RIGHT AND LEFT WHEEL BRAKE SYSTEM

1. Working in cockpit, tag and disconnect hose (1) from PRESS port (2) of pilot's right brake cylinder (3).
2. Install cap (4) in port (2) of cylinder (3).
3. Tag and disconnect hose (5) from RTN port (6) of cylinder (3).
4. Install plug (7) in hose (5).
5. Connect hose (1) to port (6) of cylinder (3).
6. Remove bleed plug (8) from port (9) of cylinder (3).
7. Connect hose (10) to port (9) of cylinder (3). Position loose end of hose in container.
8. Install plug (11) in hose (10).

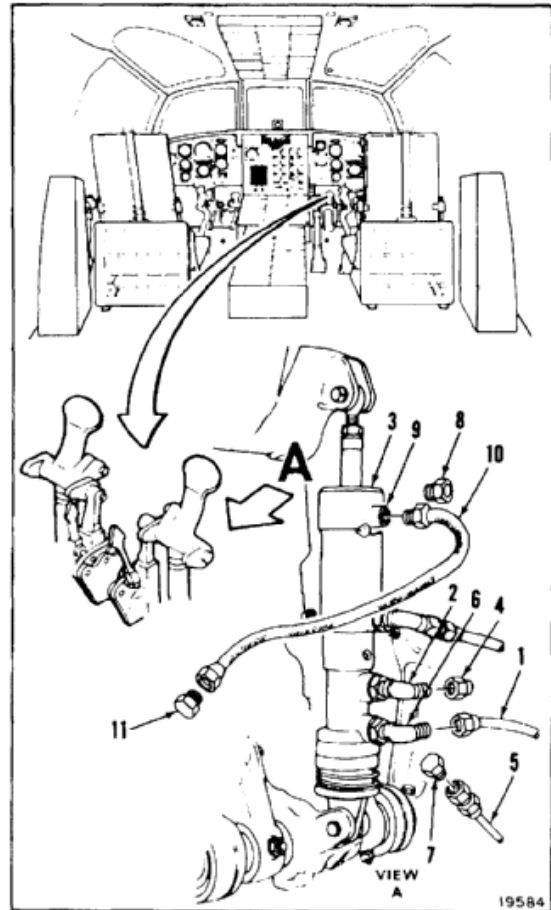

9. Working at right forward landing gear, connect bleed hoses (12) to bleed fittings (13) of two wheel brake cylinders (14 and 15). Position hoses in container.

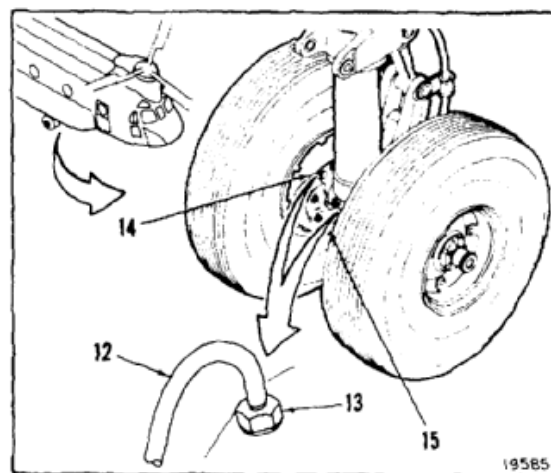

10. Working at right aft landing gear, connect bleed hose (16) to bleed fitting (17) of wheel brake cylinder (18).

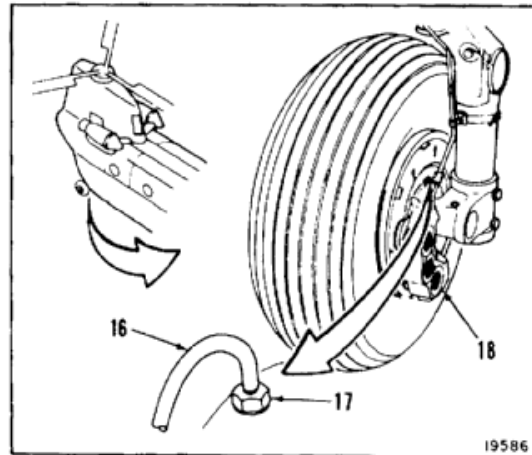

11. Operate the APU (Task 1-36).
12. Set BRAKE STEER switch (19) on cockpit overhead panel to ON.

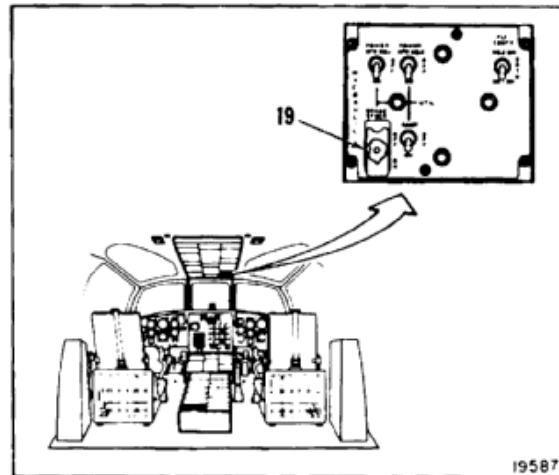

13. Loosen plug (11) in hose (10) from cylinder (3). Let fluid flow until air-free. Tighten plug.

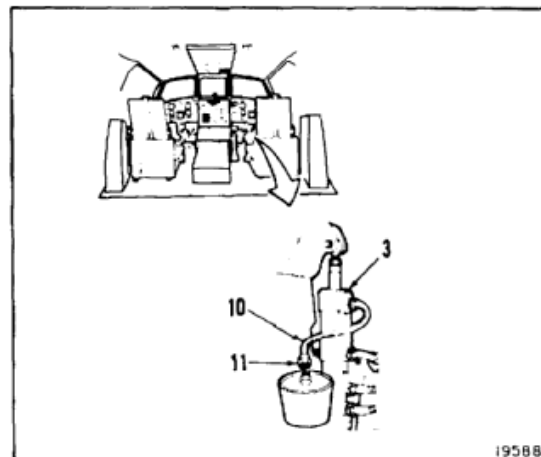

7-340 BLEED WHEEL BRAKE HYDRAULIC SYSTEM (WITHOUT EXTERNAL POWER) (Continued)

7-340

14. Working at right forward landing gear, loosen bleed fittings (13) to two cylinders (14 and 15). Let fluid flow until air-free. Tighten fittings.
15. Disconnect hoses (12) from two cylinders (14 and 15).

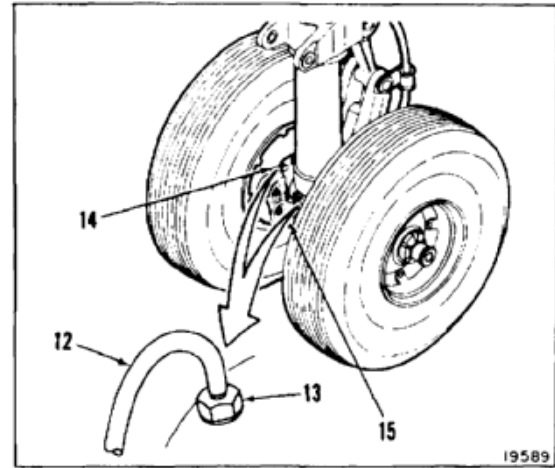

16. Working at right aft landing gear, loosen bleed fitting (17) of hose (6). Let fluid flow until air-free. Tighten fitting.
17. Disconnect hose (16) from fitting (17) of cylinder (18).

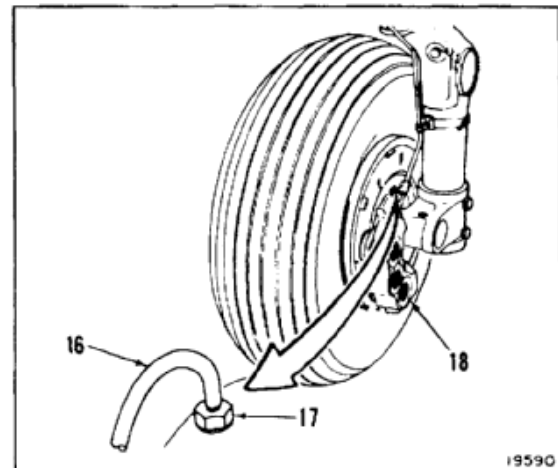

18. Working in cockpit, remove plug (11) from hose (10). Use cloth (E120) for spilled fluid. Use gloves (E186).
19. Disconnect hose (10) from port (9) of cylinder (3).
20. Install plug (8) in port (9).
21. Disconnect PRESS hose (1) from port (6) of cylinder (3).
22. Remove plug (7) from RETURN hose (5).
23. Connect hose (5) to RTN port (6) of cylinder (3). Remove tag.
24. Remove cap (4) from port (2).
25. Connect hose (1) to PRESS port (2) of cylinder (3). Remove tag.
26. Repeat steps 1 thru 25 for pilot's left brake cylinder and left forward and aft wheel brake cylinders.

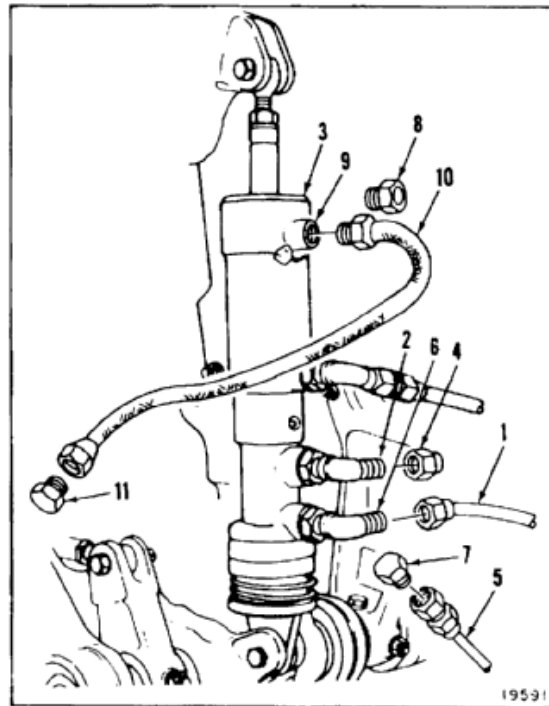

COPILOT'S RIGHT AND LEFT WHEEL BRAKE SYSTEM

27. Repeat steps 1 thru 8 for copilot's right brake cylinder.
28. Working left of console, connect bleed hose (19) to fitting (20) of inboard transfer valve (21).
29. Repeat step 13 for copilot's right cylinder.
30. Loosen fitting (20) of valve (21). Let fluid flow until air-free. Tighten fitting.
31. Disconnect hose (19) from fitting (20).
32. Repeat steps 18 thru 25 for copilot's right cylinder.
33. Repeat steps 1 thru 8 for copilot's left brake cylinder.
34. Repeat steps 29 thru 31 for outboard transfer valve.
35. Repeat step 13 for copilot's left cylinder.
36. Repeat steps 30 and 31 for outboard transfer valve.

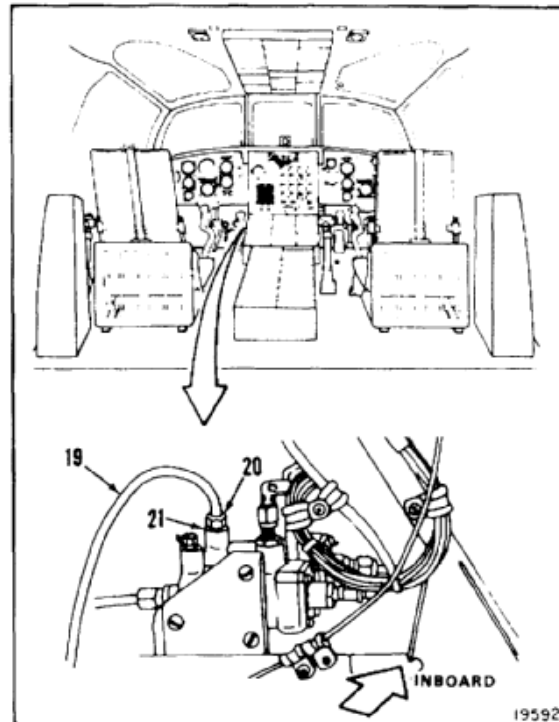

7-340 BLEED WHEEL BRAKE HYDRAULIC SYSTEM (WITHOUT EXTERNAL POWER) (Continued)

7-340

37. Repeat steps 18 thru 25 for co-pilot's left cylinder.
38. Working from forward left work platform, loosen nut (22) of brake accumulator (23). Let fluid flow until air-free. Tighten nut.

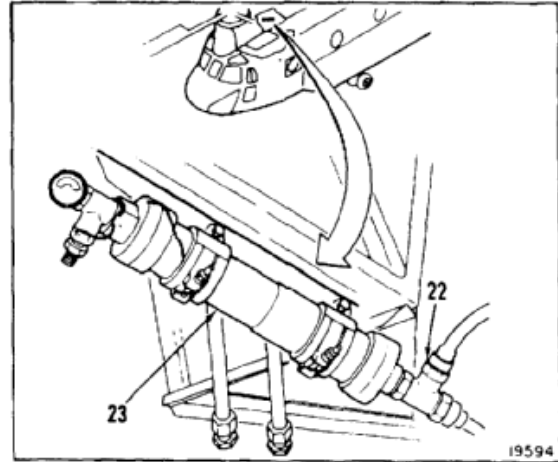

39. Set BRAKE STEER switch (19) on cockpit overhead panel to OFF.
40. Shut down the APU (Task 1-36).

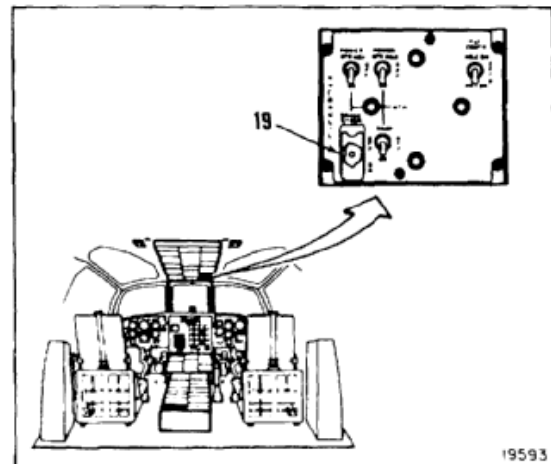
INSPECT

FOLLOW-ON MAINTENANCE:

- Disconnect battery (Task 1-39).
- Close forward left work platform (Task 2-2).
- Close aft landing gear access panels (Task 2-2).

END OF TASK

INITIAL SETUP

Applicable Configurations:

All

Tools:

Hydraulic Repairer's Tool Kit, NSN 5180-00-323-4891
 Bleed Hose
 Container, 2 Quart

Materials:

Cloth (E120)
 Bleed Hose (Tubing) (E428)
 Gloves (E186)

Personnel Required:

Aircraft Pneudraulics Repairer (2)
 Inspector

References:

Task 1-36

Equipment Condition:

Battery Connected (Task 1-39)
 Electrical Power Off
 Hydraulic Power Off
 Power Steering and Swivel Lock Accumulator
 Serviced (Task 1-66)
 Brake Steer Switch Set to On (Task 1-66)
 Aft Landing Gear Access Panels Open (Task 2-2)

General Safety Instructions:**WARNING**

Hydraulic fluid (E199) is toxic. It can irritate skin and cause burns. Avoid inhaling. Use only with adequate ventilation. Avoid contact with skin, eyes, or clothing. In case of contact, immediately flush skin or eyes with water for at least **15 minutes**. Get medical attention for eyes.

WARNING

Hydraulic fluid ejected under pressure can cause injury to personnel. Hydraulic fluid sprayed into the air is a fire hazard.

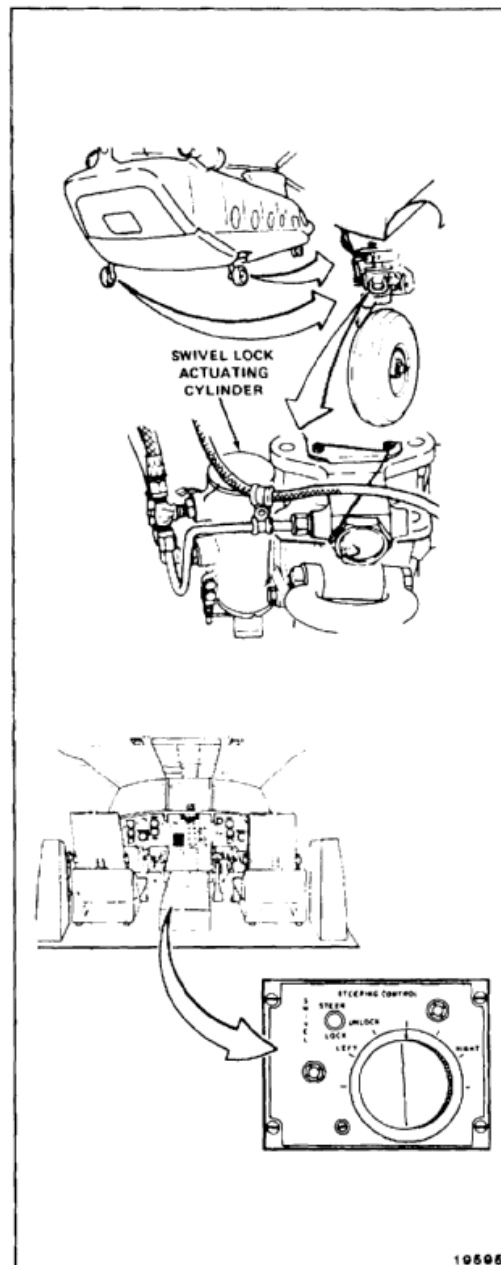

NOTE

Throughout this task, whenever a connection is loosened to let air escape from a hydraulic line, use a container and cloths (E120) to catch spilled fluid. Wear gloves (E186).

1. Operate the APU (Task 1-36).



Swivel lock actuator UNLOCK port is pressurized when swivel lock switch is at STEER or UNLOCK.

2. Working at aft left landing gear, loosen nut (1) of hose (2) to UNLOCK port (3) of swivel lock actuator (4). Allow fluid to flow for **1 minute**, after fluid is air free. Tighten nut. Use container and cloths (E120) for spilled fluid. Use gloves (E186).
3. Repeat step 2 for aft right swivel lock actuator.
4. Working at aft left landing gear, remove plug (5) from centering cam (6).
5. Install bleeder hose (7) in port (8) of centering cam (6). Position hose in container.

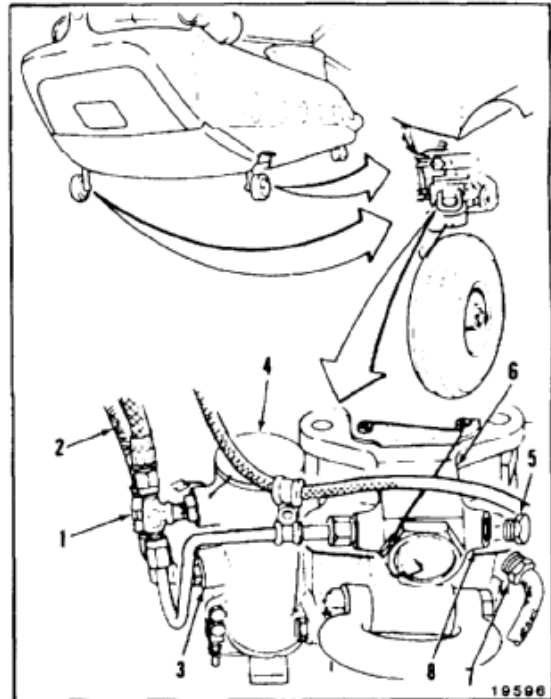

6. Working in cockpit, set swivel switch (9) of STEERING CONTROL panel (10) to LOCK.

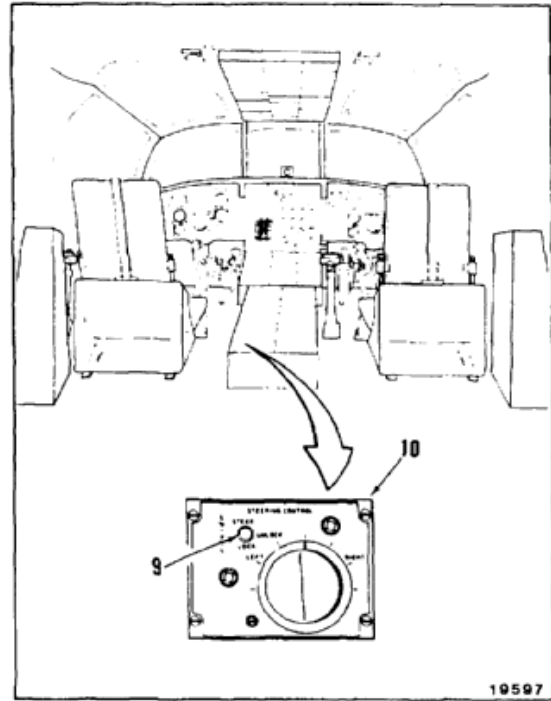

7. Working at aft left landing gear, allow fluid to flow from hose (7) until air free.

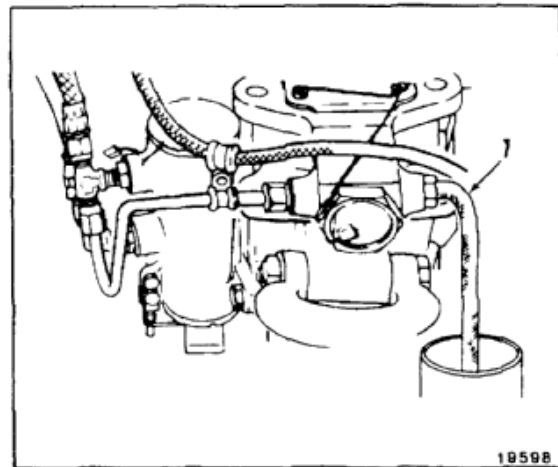

7-341 BLEED SWIVEL LOCK HYDRAULIC SYSTEM (WITHOUT EXTERNAL POWER) (Continued)

7-341

8. Working in cockpit, set SWIVEL switch (9) to UNLOCK.

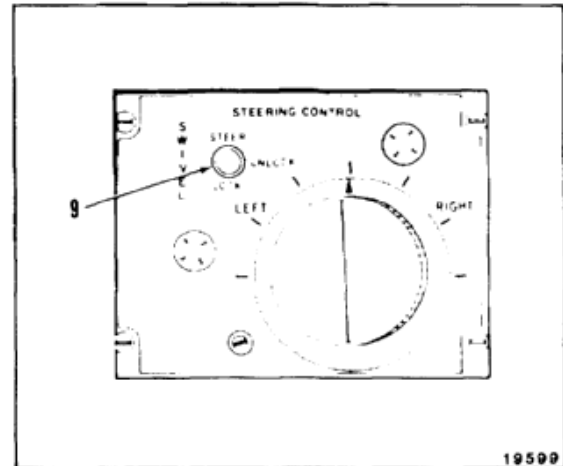

9. Working at aft left landing gear, disconnect hose (7) from cam (6).
10. Install plug (5) in port (8) of cam (6).
11. Repeat steps 4 thru 10 for right aft landing gear.
12. Shut down the APU (Task 1-36).

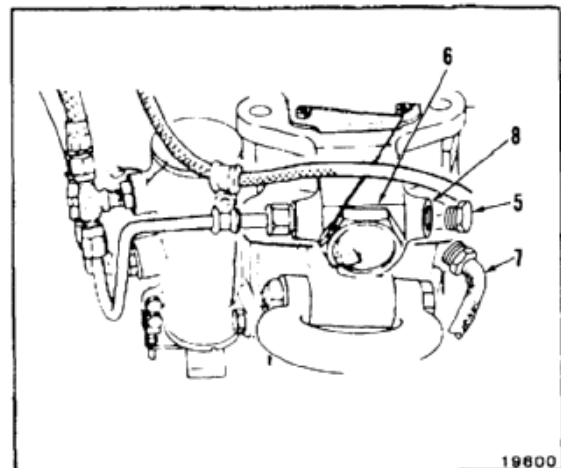
INSPECT

FOLLOW-ON MAINTENANCE:

- Disconnect battery (Task 1-36).
Close aft landing gear access panels (Task 2-2).

END OF TASK

INITIAL SETUP

Applicable Configurations:

All

Tools:

Hydraulic Repairer's Tool Kit, NSN 5180-00-323-4891

Materials:

None

Personnel Required:

Aircraft Pneudraulics Repairer (2)

References:

Task 1-36

Equipment Condition:

- Battery Connected (Task 1-39)
- Electrical Power On
- Hydraulic Power Off
- Power Steering and Swivel Lock Accumulator Serviced (Task 1-66)
- Aft Right Landing Gear Jacked (Task 1-24)
- Aft Right Landing Gear Access Panel Open (Task 2-2)
- Steering Control Panel SWIVEL Switch Set to UNLOCK (TM 55-1520-240-T)
- BRAKE STEER Switch Set to ON (TM 55-1520-240-T)

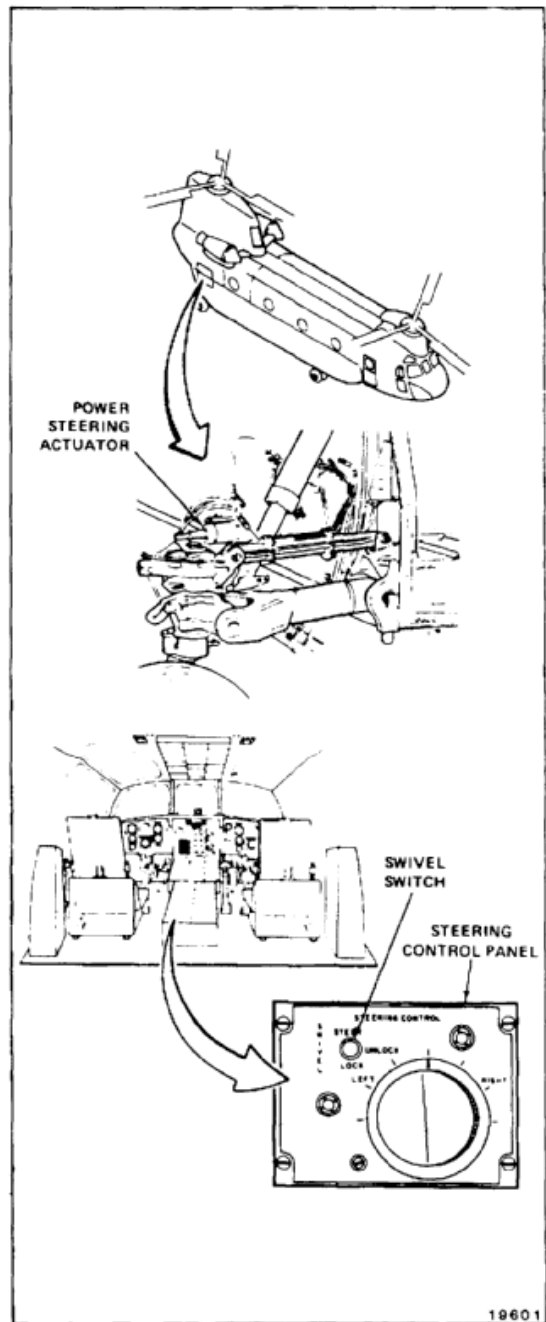

7-342 BLEED POWER STEERING HYDRAULIC ACTUATOR (WITHOUT EXTERNAL POWER) (Continued)

7-342

WARNING

Stand clear of wheel. Serious injury may occur during wheel movement.

1. Operate the APU (Task 1-36).
2. Have helper in cockpit set SWIVEL switch (1) of STEERING CONTROL panel (2) to STEER.
3. Rotate knob (3) of panel (2) fully left, then fully right.
4. Check movement of aft right wheel (4). Wheel must turn smoothly when knob (3) is rotated.
5. Repeat step 3 **ten times**.
6. Set knob (3) to mid-position.
7. Set switch (1) to UNLOCK.
8. Shut down the APU (Task 1-36).

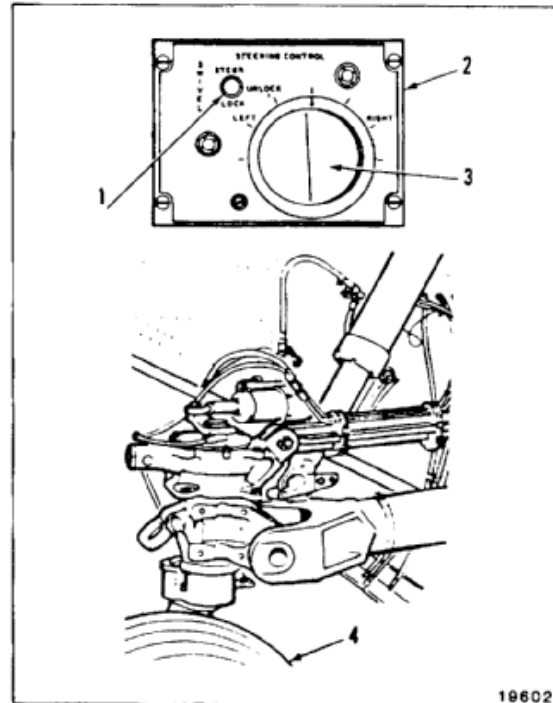
FOLLOW-ON MAINTENANCE:

- Set BRAKE STEER switch to OFF (TM 55-1520-240-T).
- Disconnect battery (Task 1-39).
- Lower and remove jack (Task 1-24).
- Close aft right landing gear access panel (Task 2-2).

END OF TASK

INITIAL SETUP

Applicable Configurations:

All

Tools:

Hydraulic Repairer's Tool Kit, NSN 5180-00-323-4891
Container, 2 Quart

Materials:

Cloths (E120)
Hydraulic Fluid (E199)
Gloves (E186)
Lockwire (E228)

Parts:

Packing
Washer

Personnel Required:

Aircraft Pneudraulics Repairer (2)

References:

Task 1-36

Equipment Condition:

Battery Connected (Task 1-39)
Electrical Power On
Hydraulic Power Off
Heater Compartment Acoustic Blanket Removed
(Task 2-208)

General Safety Instructions:**WARNING**

Hydraulic fluid (E199) is toxic. It can irritate skin and cause burns. Avoid inhaling. Use only with adequate ventilation. Avoid contact with skin, eyes, or clothing. In case of contact, immediately flush skin or eyes with water for at least **15 minutes**. Get medical attention for eyes.

Hydraulic fluid ejected under pressure can cause injury to personnel.
Hydraulic fluid sprayed into the air is a fire hazard.

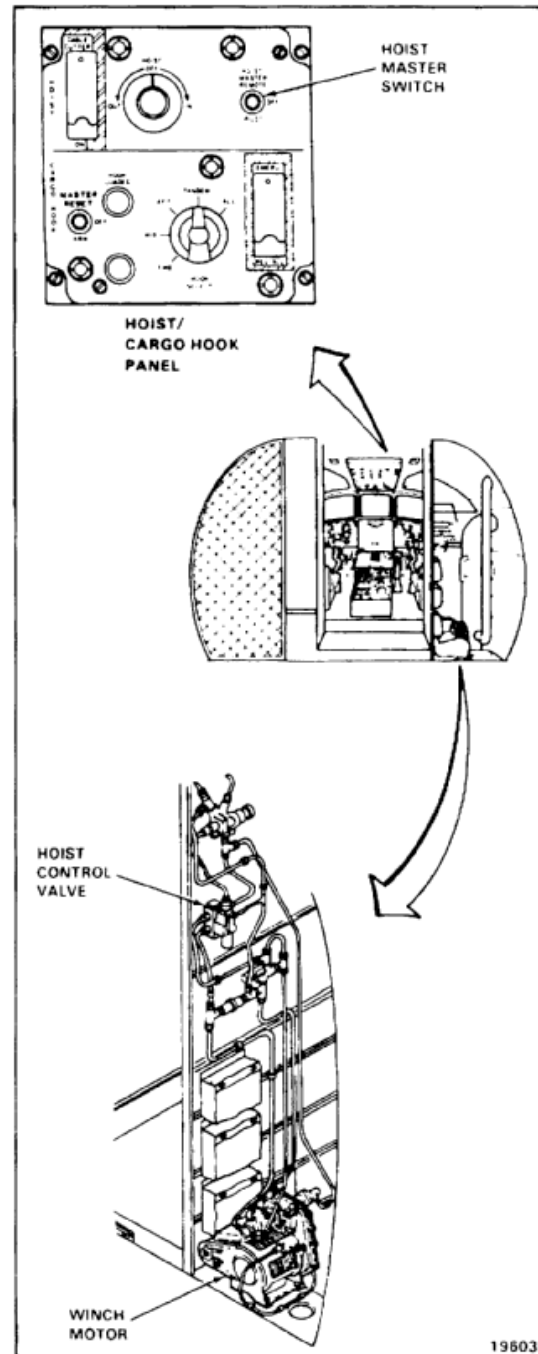

NOTE

Throughout this task, whenever a connection is loosened to let air escape from a hydraulic line, use a container and cloths (E120) to catch spilled fluid. Wear gloves (E186).

1. Disconnect drain hose (1) from winch motor (2).
2. Loosen nut (3) of elbow (4). Remove elbow, packing (5), and washer (6).
3. Fill motor (2) through port (7) with fluid (E199). Tap motor with soft-faced hammer to remove trapped air.
4. Install washer (6) and packing (5) on elbow (4).
5. Install elbow (4). Tighten nut (3).

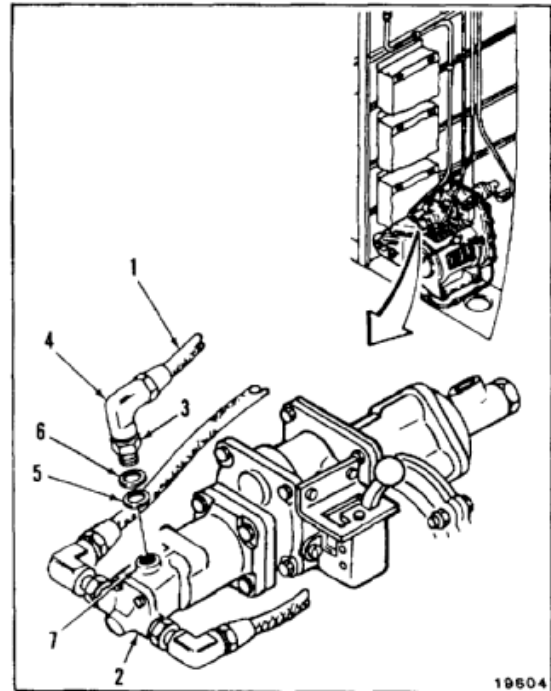

6. Operate the APU (Task 1-36).
7. Set HOIST MASTER switch (8) on overhead panel to REMOTE or PILOT.
8. Loosen nut (9) on hose (10).
9. Remove lockwire (11) from knob (12) on control valve (13). Rotate knob forward until fluid flows from hose (10). Let fluid flow until air-free. Release knob.
10. Tighten nut (9).
11. Loosen nut (14) on hose (15).
12. Rotate knob (12) aft until fluid flows from hose (15). Let fluid flow until air-free. Release knob.
13. Tighten nut (14).

WARNING

Cable must be manually controlled during reel-in and reel-out to prevent entanglement, snags, and injury to personnel.

14. Rotate knob (12) aft. Let about **10 feet** of cable reel out.
15. Rotate knob (12) forward to reel in cable.
16. Set HOIST MASTER switch (8) to OFF.
17. Shut down the APU (Task 1-36).
18. Lockwire knob (12). Use lockwire (E228) (11).

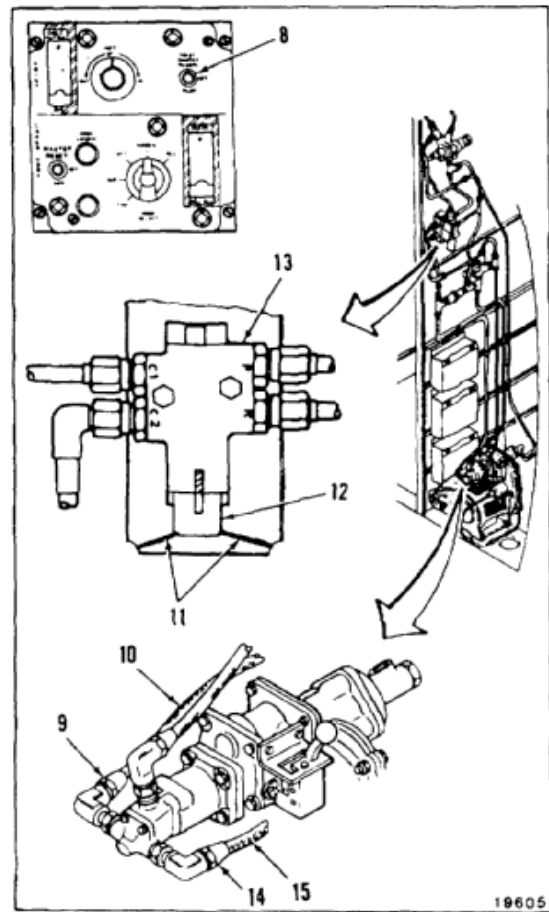

FOLLOW-ON MAINTENANCE:

- Install heater compartment acoustic blanket (Task 2-210).
- Disconnect battery (Task 1-39).

END OF TASK

7-1270

INITIAL SETUP

Applicable Configurations:

All

Tools:

Hydraulic Repairer's Tool Kit, NSN 5180-00-323-4891
Hand Oiler

Materials:

Cloths (E120)
Hydraulic Fluid (E199)
Bleed Hose (Tubing) (E428)
Gloves (E186)

Personnel Required:

Aircraft Pneudraulics Repairer (2)

Equipment Condition:

Battery Connected (Task 1-39)
Electrical Power On
Hydraulic Power Off
Right Forward Work Platform and Pylon Right Access
Door Open, As Required (Task 2-2)

No. 1 or No. 2 Flight Control Reservoir/Cooler
Serviced (Task 1-60 or 1-61)
Hydraulic Panel POWER XFR 1 Switch Set to ON
(Task 7-16.2)

References:

Task 1-36

General Safety Instructions:

WARNING

Hydraulic fluid (E199) is toxic. It can irritate skin and cause burns. Avoid inhaling. Use only with adequate ventilation. Avoid contact with skin, eyes, or clothing. In case of contact, immediately flush skin or eyes with water for at least **15 minutes**. Get medical attention for eyes.

Hydraulic fluid ejected under pressure can cause injury to personnel. Hydraulic fluid sprayed into the air is a fire hazard.

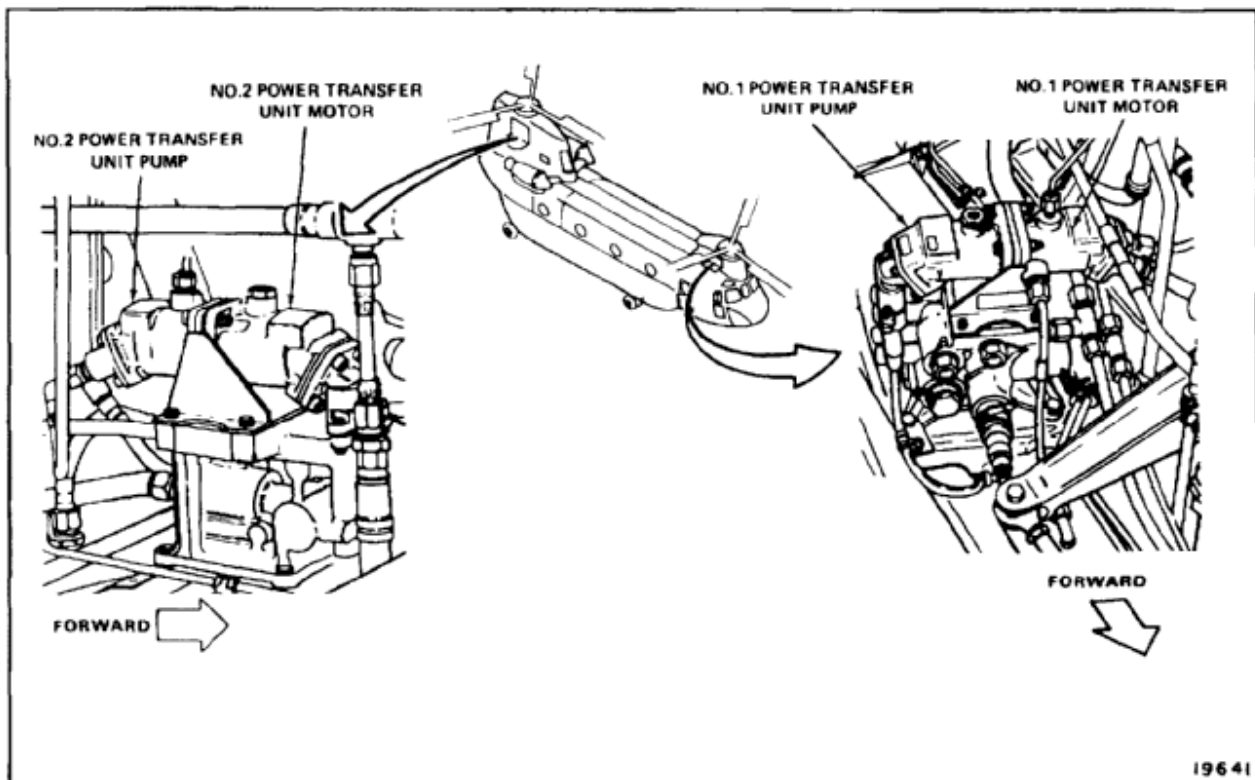

NOTE

Procedure is same to bleed No. 1 or No. 2 PTU motor and pump. No. 1 motor and pump is shown here.

1. Remove plug (1) from port (2) of No. 1 PTU motor (3).
2. Fill pump (3) through port (2) with fluid (E199). Use hand oiler. Use cloths (E120) for spilled fluid.
3. Install plug (1) in port (2).
4. Disconnect drain tube (4) from port (5) of pump (6).
5. Fill motor (6) through port (5) with fluid (E199). Use hand oiler. Use cloths (E120) for spilled fluid. Wear gloves (E186).
6. Connect tube (4) to port (5).

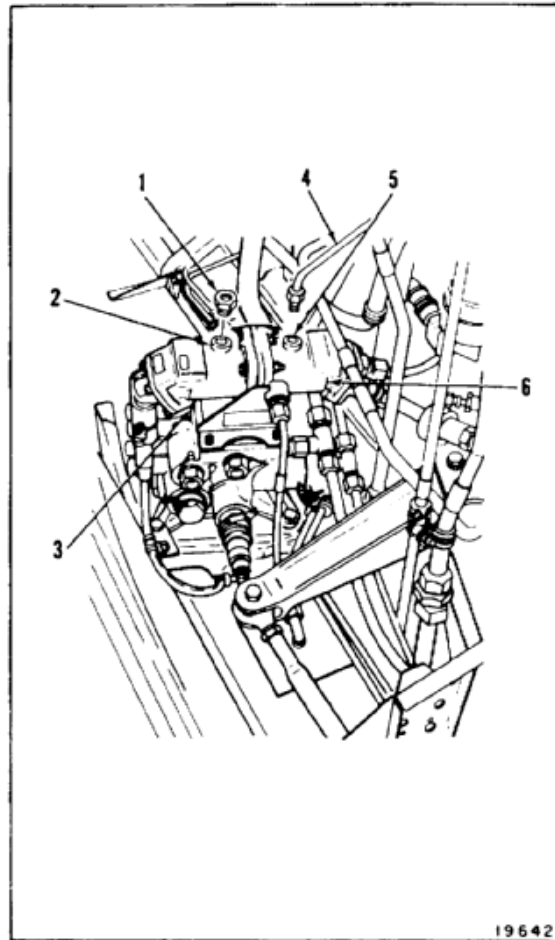

7. Service No. 1 flight control system reservoir/cooler (7) as follows:

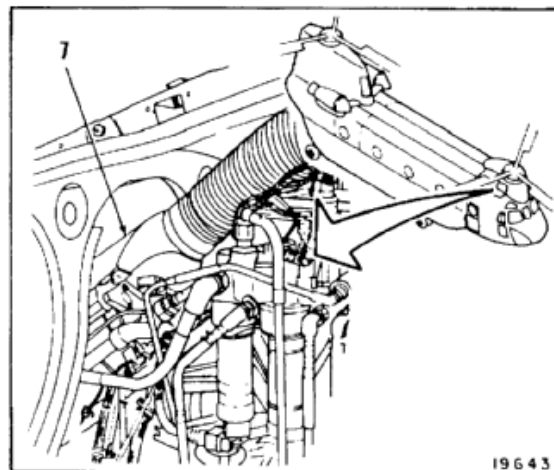

7-344 BLEED NO. 1 OR NO. 2 PTU MOTOR AND PUMP (WITHOUT EXTERNAL POWER) (Continued)

7-344

- a. Open cap (8) of fill module (9). Fill module with hydraulic fluid (E199). Close cap.
- b. Set handle (10) of selector valve (11) to position 1. Operate pump handle (12) until utility reservoir/cooler indicator (13) indicates full.

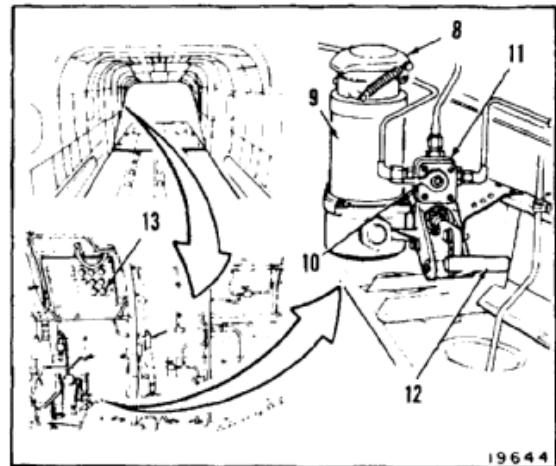

- c. Loosen clamp (14) and disconnect hose (15) from bleed valve (16) of reservoir/ cooler (7).
- d. Connect bleed hose (17) to valve (16).
- e. Open valve (16). Let fluid flow until air-free. Use container and cloths (E120) to catch spilled fluid.
- f. Close valve (16). Remove bleed hose (17). Install hose (15).
- g. Repeat steps a and b.

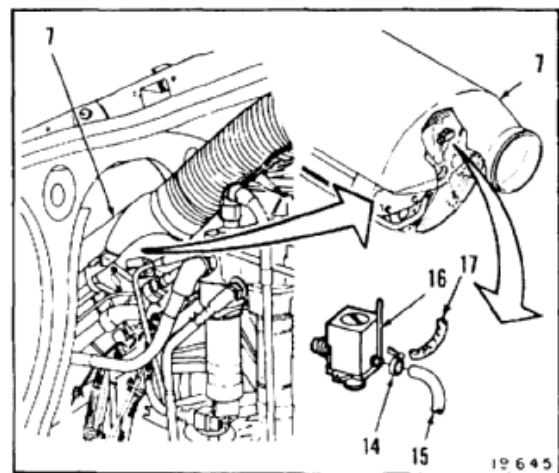

WARNING

Stand clear of ramp when lowering.
Ramp drops by gravity.

CAUTION

If a lot of air is in the circuit, the ramp may drop fast enough to be damaged as it strikes the ground. To prevent damage, place padding on the ground in the contact area.

- 8. Move ramp control handle (18) to DN. Lower ramp (19) fully.

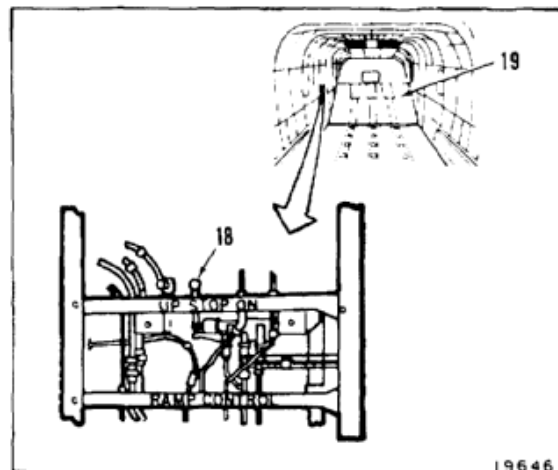

9. Working at right side of pylon, loosen clamp (20) and disconnect hose (21) from bleed valve (22) of utility reservoir/cooler (23).
10. Connect bleed hose (24) to valve (22).
11. Operate the APU (Task 1-36).
12. Open valve (22). Let fluid flow for **three minutes** to ensure that it is air-free.
13. Close valve (22). Remove bleed hose (24). Connect hose (21).
14. Shut down the APU (Task 1-36).

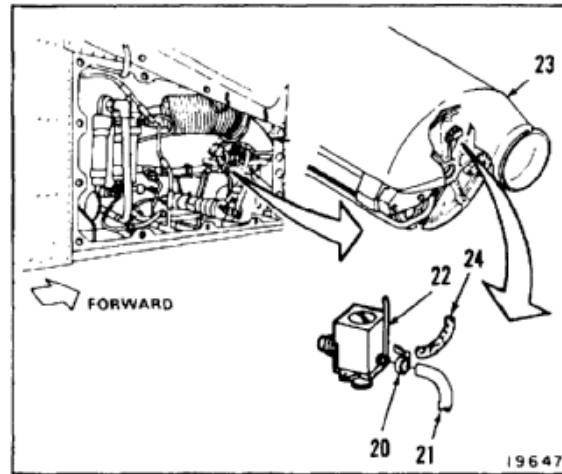

15. Open cap (8) of fill module (9). Fill module with hydraulic fluid (E199). Close cap.
16. Set handle (10) of selector valve (11) to position 3. Operate pump handle (12) until utility reservoir/cooler indicator (13) indicates full.

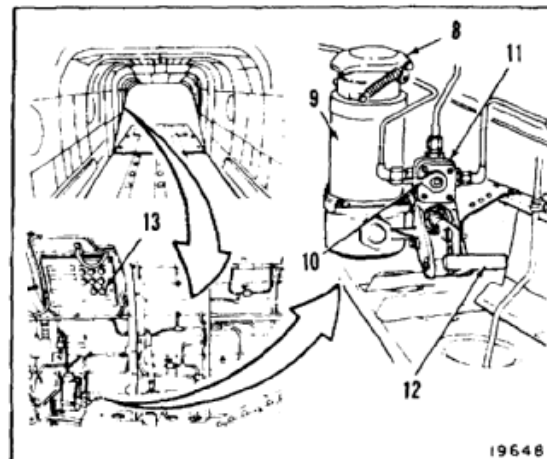

FOLLOW-ON MAINTENANCE:

- Set PWR XFR 1 switch on hydraulic panel to OFF.
- Disconnect battery (Task 1-39).
- Close right forward work platform or pylon right access door (Task 2-2).

END OF TASK

7-1274

7-345 BLEED UTILITY RESERVOIR/COOLER, APU PUMP/MOTOR AND PUMP (WITHOUT EXTERNAL POWER)

7-345

INITIAL SETUP

Applicable Configurations:

All

Tools:

- Hydraulic Repairer's Tool Kit, NSN 5180-00-323-4891
- Container, 2 Quart
- Hand Oiler
- Workstand
- Tiedown Lines (2)

Materials:

- Cloths (E120)
- Hydraulic Fluid (E199)
- Bleeder Hose (Tubing) (E428)
- Gloves (E186)

Personnel Required:

Aircraft Pneudraulics Repairer (2)

Equipment Condition:

- Battery Connected (Task 1-39)
- Electrical Power On
- Hydraulic Power Off

- Cargo Ramp Open and Level (TM 55-1520-240-T)
- APU Start Accumulator Serviced (Task 1-64)
- Engine Igniter Disconnected (TM 55-2840-254-23)
- Utility Hydraulic System Depressurized (Task 7-135.1)
- Right Pylon Access Door Open (Task 2-2)
- Aft Transmission Baffles Open (Task 2-2)
- Aft Transmission Drip Pan Removed (Task 2-3)
- APU Drip Pan Removed (Task 2-3)

General Safety Instructions:

WARNING

Hydraulic fluid (E199) is toxic. It can irritate skin and cause burns. Avoid inhaling. Use only with adequate ventilation. Avoid contact with skin, eyes, or clothing. In case of contact, immediately flush skin or eyes with water for at least **15 minutes**. Get medical attention for eyes.

Hydraulic fluid ejected under pressure can cause injury to personnel. Hydraulic fluid sprayed into the air is a fire hazard.

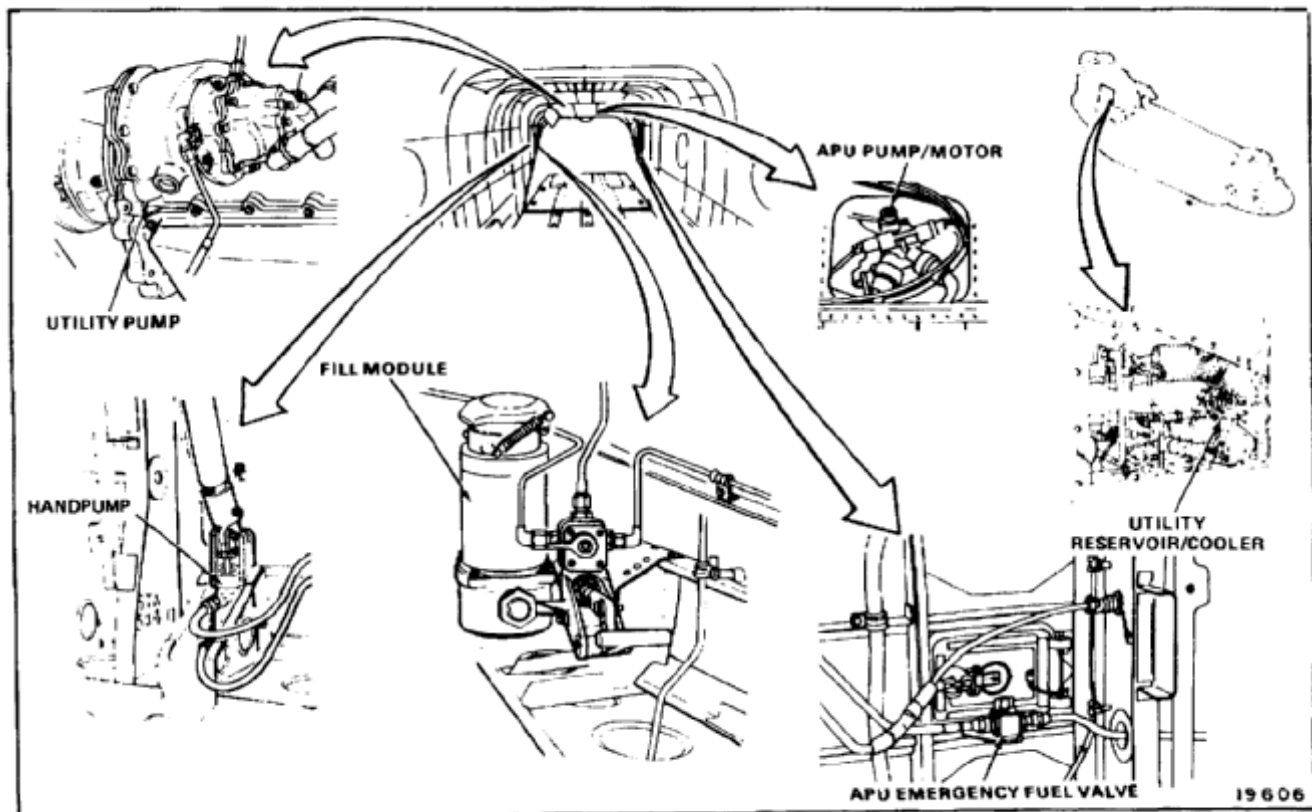

NOTE

Throughout this task, whenever a connection is loosened to let air escape from a hydraulic line, use a container and cloths (E120) to catch spilled fluid. Wear gloves (E186).

RESERVOIR/COOLER

1. Open cap (1) of fill module (2). Fill module with hydraulic fluid (E199). Close cap.
2. Set handle (3) of selector valve (4) to position 3. Operate pump handle (5) until utility reservoir/cooler indicator (6) indicates full.
3. Working at right side of pylon, loosen clamp (7) and disconnect hose (8) from bleed valve (9) of utility reservoir/cooler (10).
4. Connect bleed hose (11) to valve (9).
5. Open valve (9). Let fluid flow until air-free. Close valve. Remove bleed hose (11) and connect hose (8).
6. Repeat steps 1 and 2.
7. Loosen nut (12) of tube (13) to hand pump (14). Let fluid flow until air-free. Tighten nut.
8. Repeat steps 1 and 2.

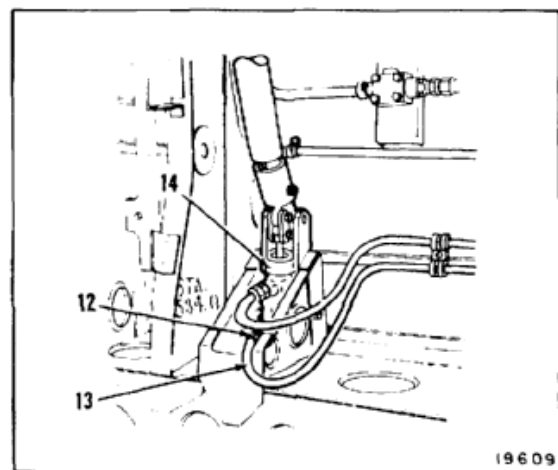
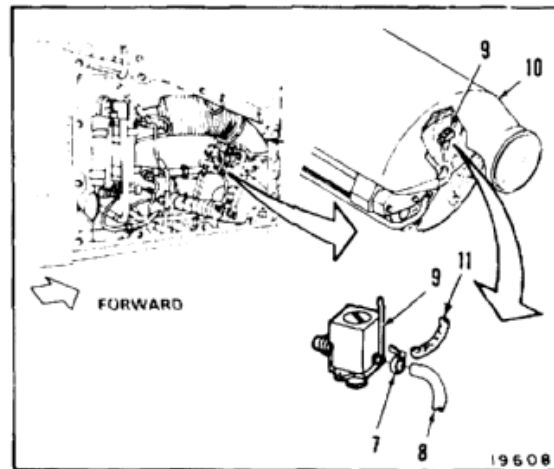
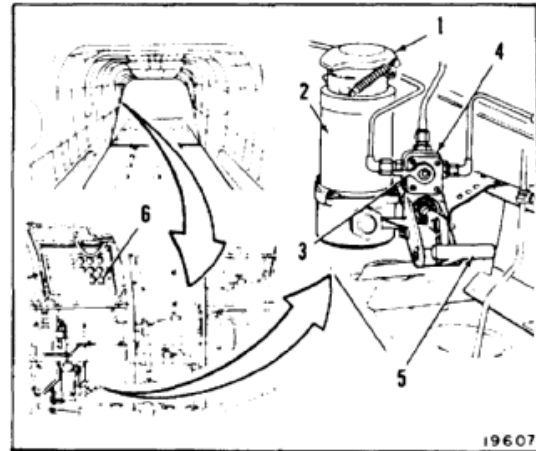

7-345 BLEED UTILITY RESERVOIR/COOLER, APU PUMP/MOTOR AND PUMP (WITHOUT EXTERNAL POWER) (Continued)

APU

9. Loosen nut (15) at SIG port (16) of APU motor/pump (17). Let fluid flow until air-free. Tighten nut.
10. Repeat steps 1 and 2.
11. Loosen nut (18) at LP port (19) of motor/ pump (17). Let fluid flow until air-free. Tighten nut.
12. Repeat steps 1 and 2.

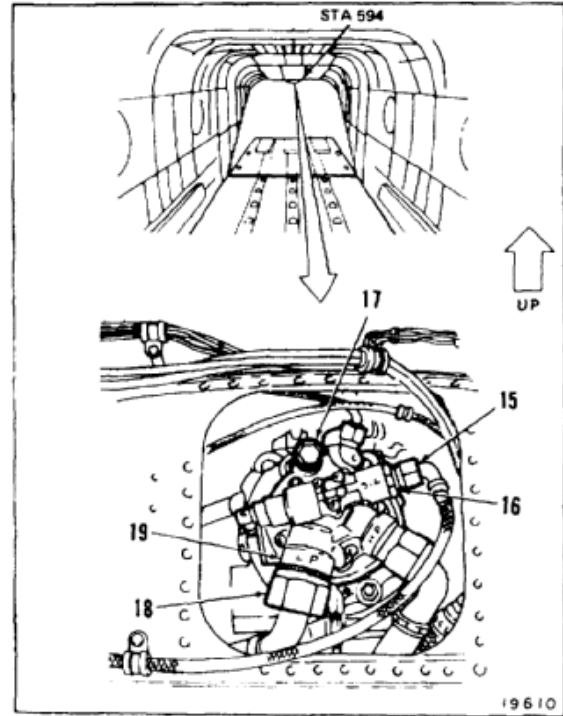

13. Loosen nut (20) at IN port (21) of utility pump (22). Let fluid flow until air-free. Tighten nut.
14. Repeat steps 1 and 2.
15. Loosen nut (23) of RETURN tube (24) to APU start accumulator manifold (25). Let fluid flow until air-free. Tighten nut.
16. Repeat steps 1 and 2.

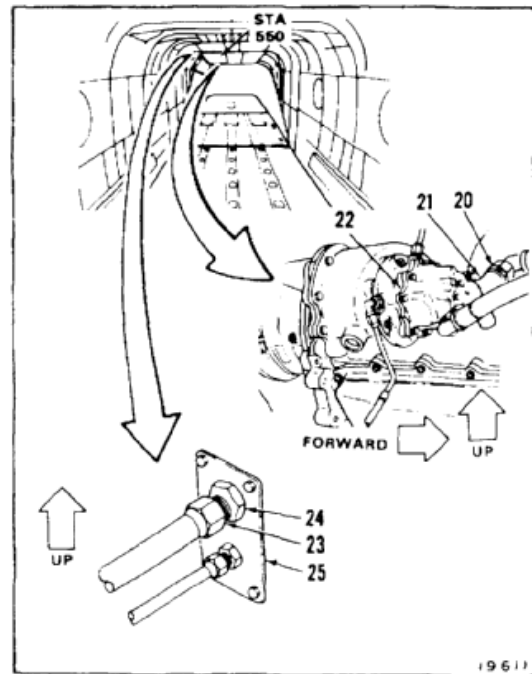

17. Disconnect electrical connector (26) from receptacle (27) on APU (28).

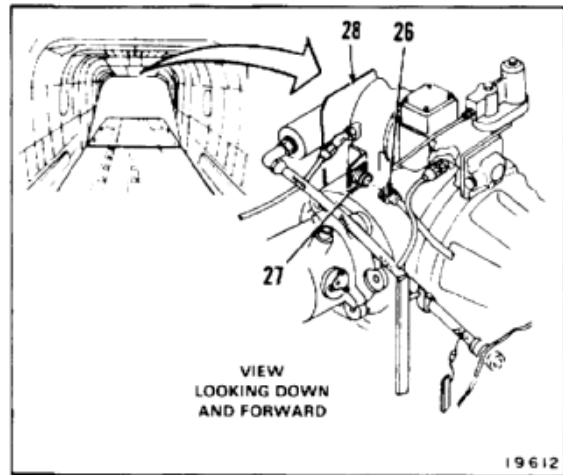

18. Go to aft left fuel pod bay. Disconnect electrical connector (29) from APU fuel pump (30). Disconnect electrical connector (31) from APU fuel valve (32).

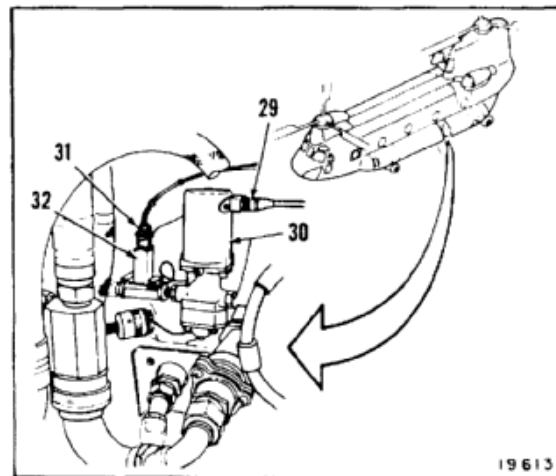

19. Operate handpump (14) to fill pressure lines.

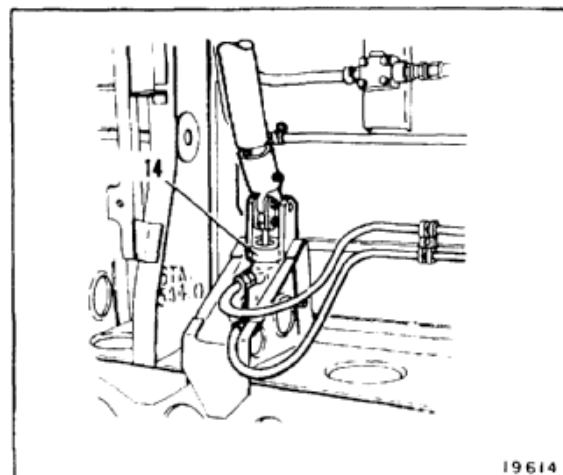

7-345 BLEED UTILITY RESERVOIR/COOLER, APU PUMP/MOTOR AND PUMP (WITHOUT EXTERNAL POWER) (Continued)

7-345

- 20. Working from ramp, loosen nut (33) of PRESSURE tube (34) at manifold (25). Let fluid flow until air-free. Tighten nut.
- 21. Repeat steps 1 and 2.

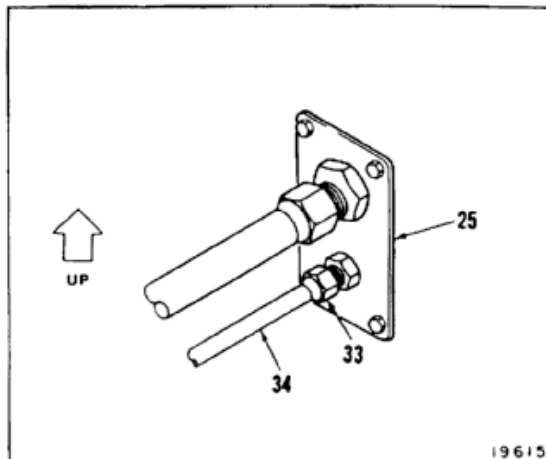

- 22. Working at right side of pylon, loosen nut (34) of pressure tube (35) at reservoir/cooler (10). Let fluid flow until air-free. Tighten nut.
- 23. Repeat steps 1 and 2.

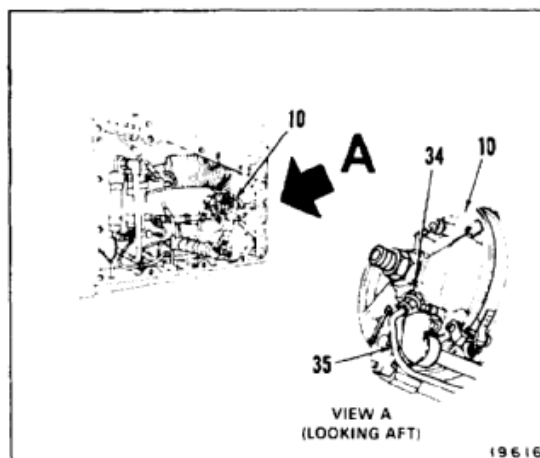

- 24. Working in cockpit, set APU switch (36) on ELECT panel (37) to START.

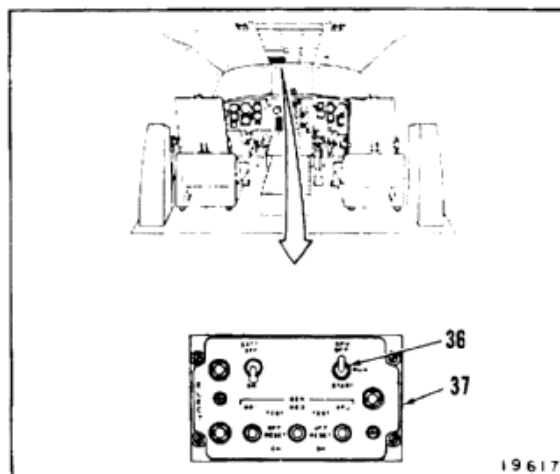

25. Have helper operate handpump (14).
26. Listen for APU motor/pump (17) to rotate. While motor/pump is rotating, loosen nut (38) of case drain tube (39) of return control module (40). Let fluid flow until air-free Tighten nut.
27. Stop operating pump (14).
28. Repeat steps 1 and 2.

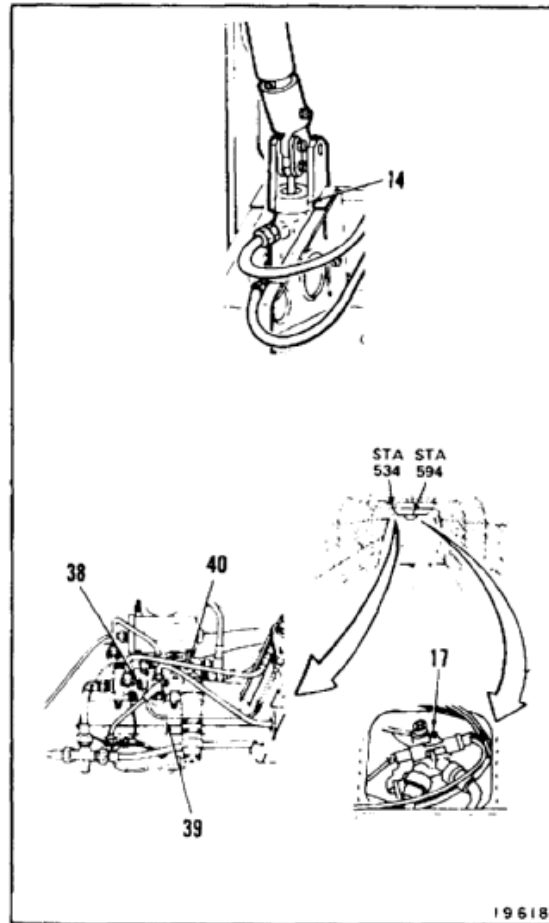

29. Working in cockpit, set APU switch (36) on ELECT panel (37) to OFF.

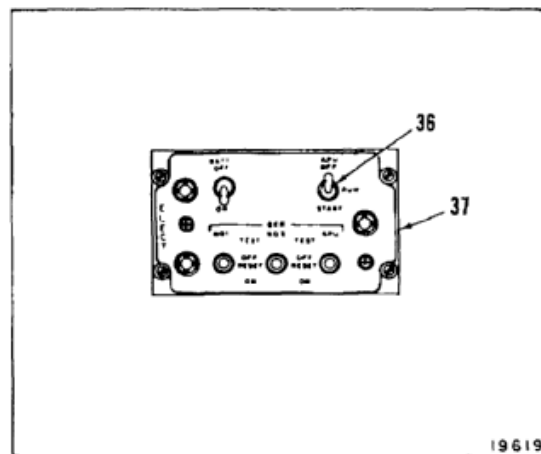

7-345 BLEED UTILITY RESERVOIR/COOLER, APU PUMP/MOTOR AND PUMP (WITHOUT EXTERNAL POWER) (Continued)

7-345

UTILITY PUMP

30. Disconnect tube (41) at case drain port (42) of utility pump (22) at right side of aft transmission (43).
31. Fill pump (22) through port (42) with hydraulic fluid (E199). Use hand oiler.
32. Connect tube (41) to port (42).

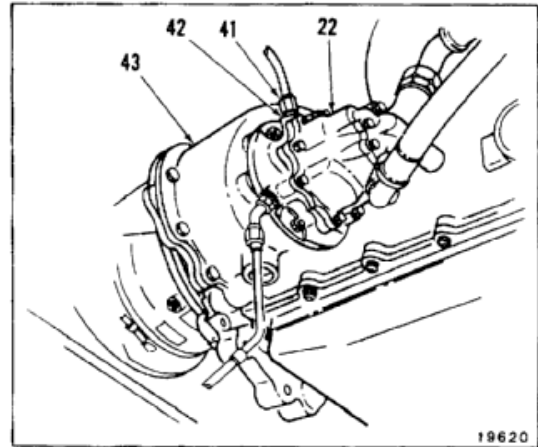

33. Operate handpump (14) to fill pressure lines.

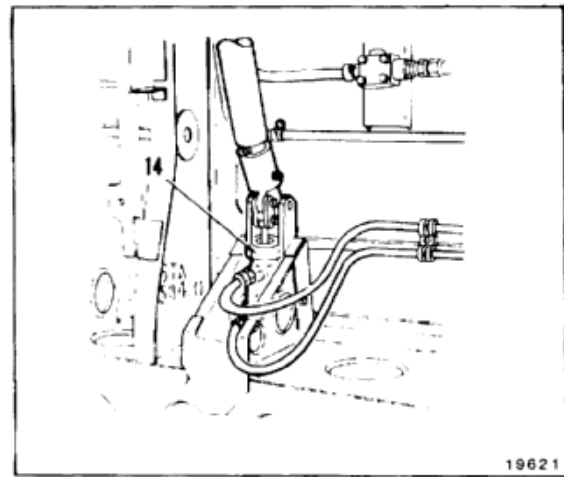

34. Loosen nut (38) of tube (39) at return control module (40). Let fluid flow until air-free.
35. Rotate aft head clockwise a minimum of **10 complete turns**, or until fluid flow from tube (39) is air-free. Use tiedown lines to turn rotor head.
36. Tighten nut (38).

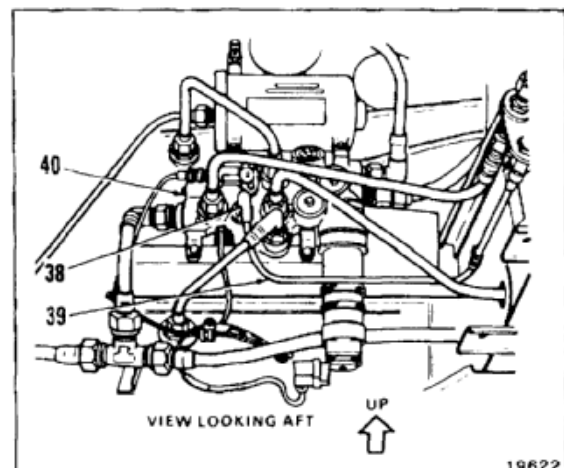

37. Working at right side of pylon, loosen clamp (7) and disconnect hose (8) from bleed valve (9) of utility reservoir/cooler (10).
38. Connect bleed hose (11) to valve (9).
39. Open valve (9). Let fluid flow until air-free. Close valve. Remove bleed hose (11) and connect hose (8). Tighten clamp (7).
40. Repeat steps 1 and 2.

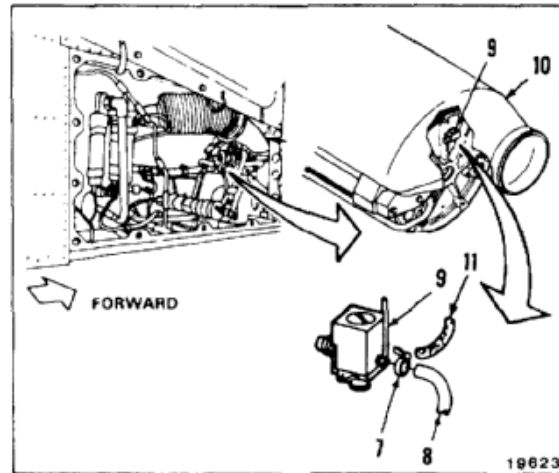

41. Connect electrical connector (26) to receptacle (27) on APU (28).

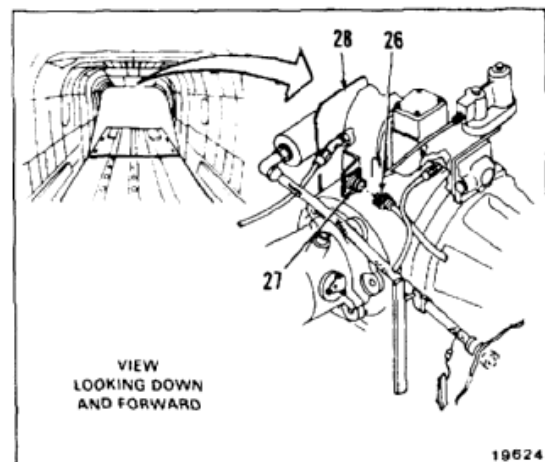

42. Go to aft left fuel pod bay. Connect electrical connector (29) to APU fuel pump (30). Connect electrical connector (31) to APU fuel valve (32).

FOLLOW-ON MAINTENANCE:

- Disconnect battery (Task 1-39).
- Close pylon right access door (Task 2-2).
- Install aft transmission drip pan (Task 2-3).
- Install APU drip pan (Task 2-3).
- Close aft transmission access panels (Task 2-2).
- Close cargo ramp (TM 55-1520-240-T).

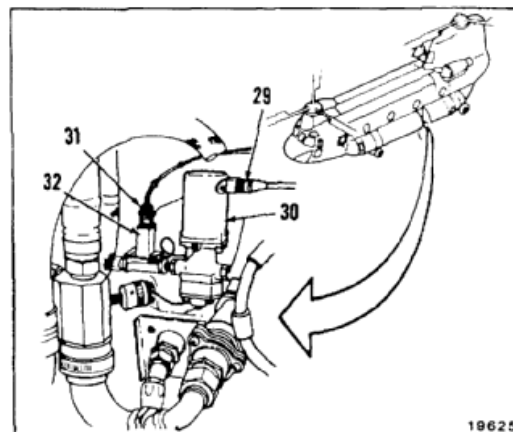

END OF TASK

INITIAL SETUP

Applicable Configurations:

All

Tools:

Hydraulic Repairer's Tool Kit, NSN 5180-00-323-4891
Container, 2 Quart

Materials:

Cloths (E120)
Gloves (E186)

Personnel Required:

Aircraft Pneudraulics Repairer (2)

Equipment Condition:

Battery Connected (Task 1-39)
Electrical Power On
Hydraulic Power On
Cargo Hook Actuator Serviced (Task 1-74)
Rescue Hatch Open (Task 2-2)

References:

Task 1-36

General Safety Instructions:**WARNING**

Hydraulic fluid (E199) is toxic. It can irritate skin and cause burns. Avoid inhaling. Use only with adequate ventilation. Avoid contact with skin, eyes, or clothing. In case of contact, immediately flush skin or eyes with water for at least **15 minutes**. Get medical attention for eyes.

Hydraulic fluid ejected under pressure can cause injury to personnel. Hydraulic fluid sprayed into the air is a fire hazard.

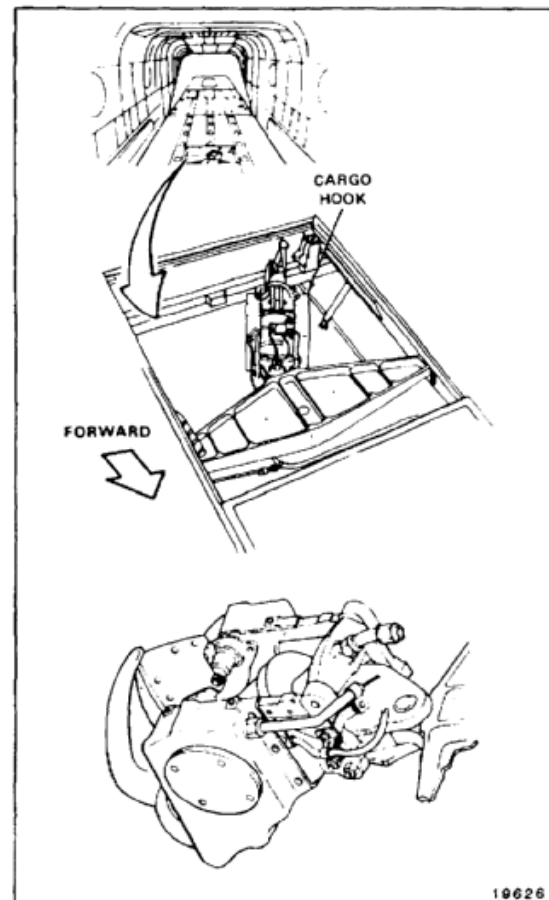

1. Have helper support hook (1). Release stowage strap (2).
2. Lower hook (1) until it hangs free.

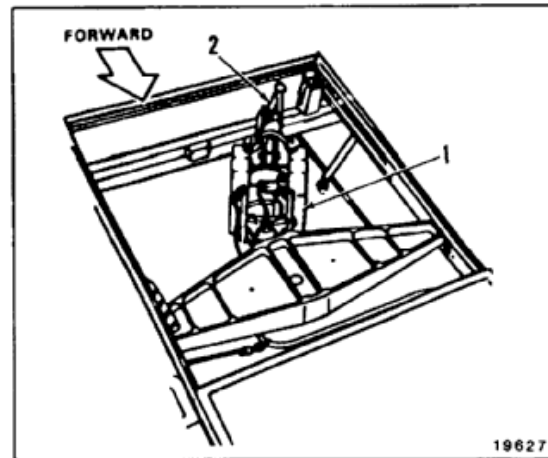

3. Operate the APU (Task 1-36).
4. Loosen nut (3) of pressure hose (4). Allow fluid to flow until air free. Tighten nut. Use container and cloths (E120) for spilled fluid. Wear gloves (E186).

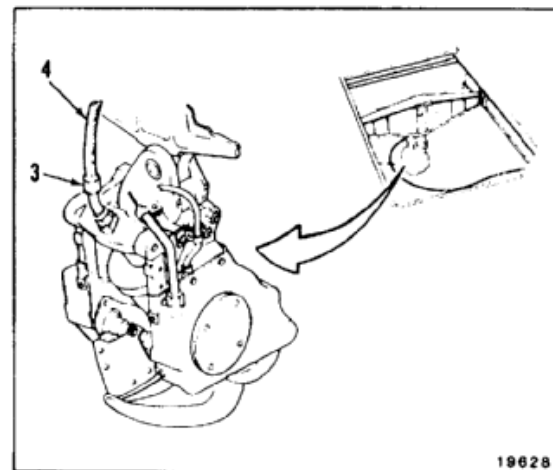

5. Working in cockpit, set HOOK SELECT switch (5) to MID on CARGO HOOK panel (6).
6. Set MASTER switch (7) to ARM.
7. Press and release CARGO HOOK RELEASE switch (8) on pilot's or copilot's control stick (9). Check cargo hook opens.
8. Set switch (7) to RESET. Check cargo hook closes.
9. Repeat steps 6, 7, and 8 **five times**.
10. Repeat step 4.
11. Set switch (7) to OFF.
12. Shut down the APU (Task 1-36).

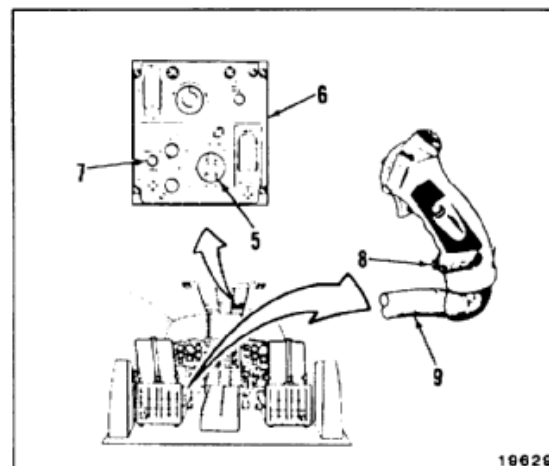

7-346 BLEED CENTER CARGO HOOK HYDRAULIC SYSTEM WITHOUT EXTERNAL POWER (Continued)

7-346

13. Have helper lift cargo hook (1) to stowed position. Slide stowage strap (2) through hook (10) and tighten strap.

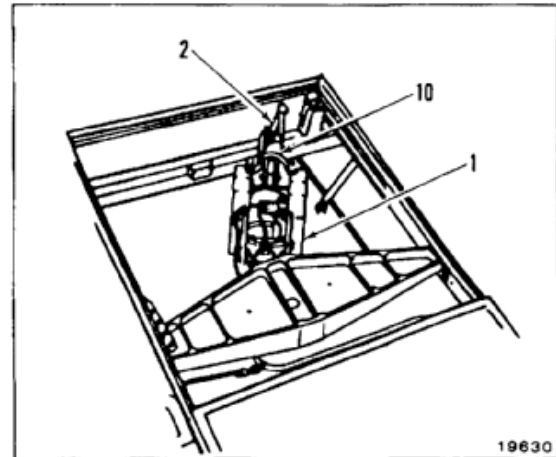
***FOLLOW-ON MAINTENANCE:***

- Close rescue hatch (Task 2-2).
- Disconnect battery (Task 1-39).

END OF TASK

INITIAL SETUP

General Safety Instructions:

Applicable Configurations:

Without **74**

Tools:

Hydraulic Repairer's Tool Kit, NSN 5780-00-323-4891
 Container, 2 Quart
 Reducers, MS21916D12-10

Materials:

Cloths (E120)
 Gloves (E184.1)

Personnel Required:

Aircraft Pneudraulics Repairer
 Inspector

References:

Task 1-36

Equipment Condition:

Battery Connected (Task 1-39)
 Electrical Power On
 Hydraulic Power Off
 Engine Access Covers Open (Task 4-49)

WARNING

Hydraulic fluid (E199) is toxic. It can irritate skin and cause burns. Avoid inhaling. Use only with adequate ventilation. Avoid contact with skin, eyes, or clothing. In case of contact, immediately flush skin or eyes with water for at least **15 minutes**. Get medical attention for eyes.

WARNING

Hydraulic fluid ejected under pressure can cause injury to personnel. Hydraulic fluid sprayed into the air is a fire hazard.

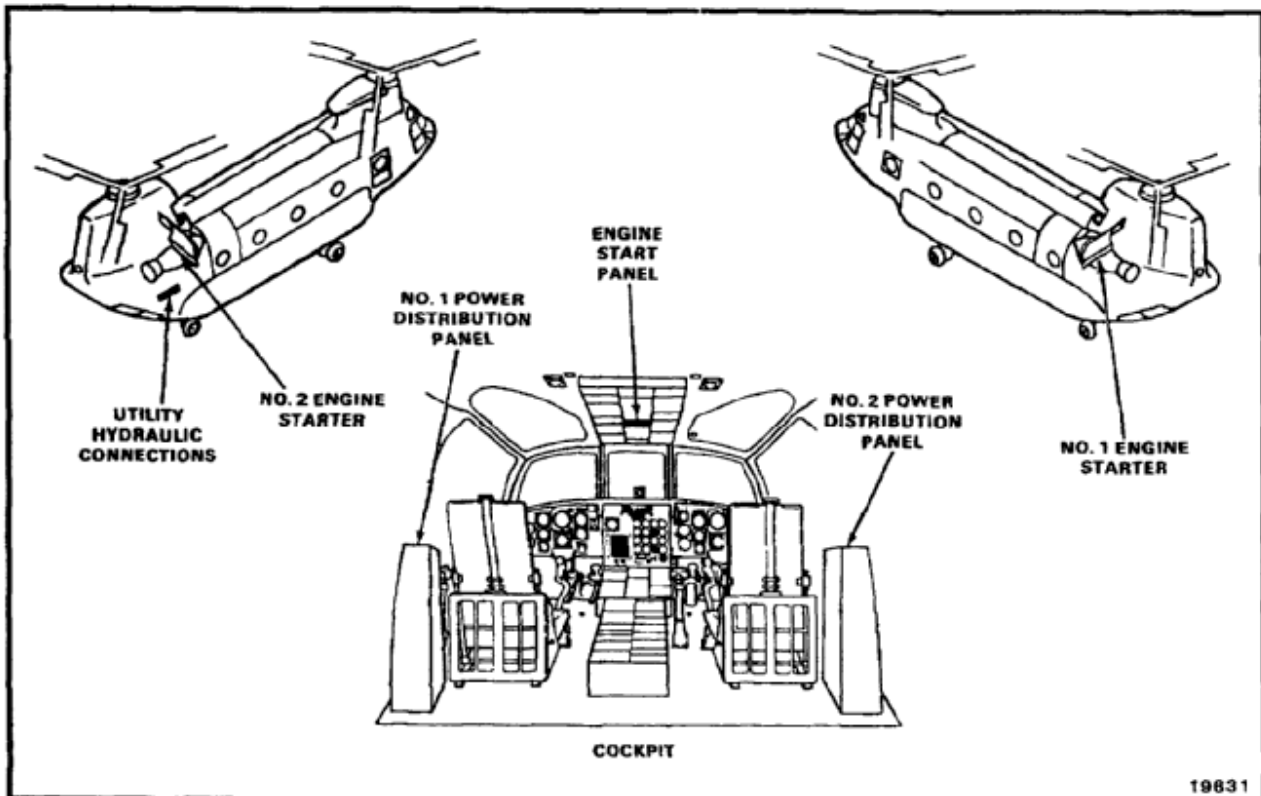

7-347 BLEEDING ENGINE START HYDRAULIC SYSTEMS (WITHOUT EXTERNAL POWER) (Continued)

7-347

1. In cockpit, place ENGINE 1 start switch (1) and ENGINE 2 start switch (2) on START panel (3) to OFF.
2. Pull out ENGINE NO. 1 IGN circuit breaker (4) on No. 1 PDP (5) to OFF.
3. Pull out ENGINE No. 2 IGN circuit breaker (6) on No. 2 PDP (7).

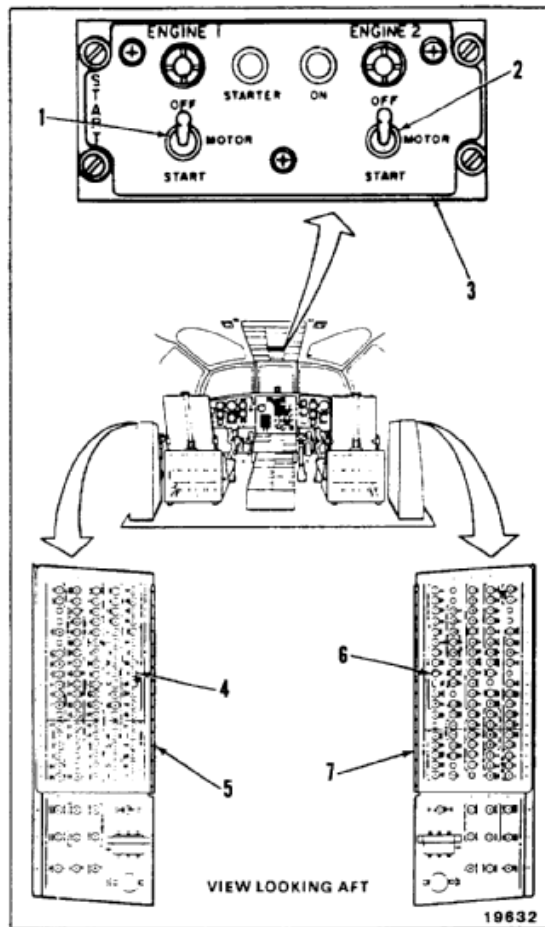

NO. 1 ENGINE

4. Disconnect pressure line (8) and return line (9) from engine starter (10). Wear gloves (E184.1).
5. Connect pressure line (8) to return line (9) with reducer.
6. Operate the APU (Task 1-36).
7. Set ENGINE 1 start switch (1) on cockpit START panel (3) to MOTOR. After **5 minutes** set switch (1) to OFF.
8. Shut down the APU (Task 1-36).
9. At engine, disconnect pressure line (8) from return line (9).
10. Connect pressure line (8) and return line (9) to engine starter (10).
11. Operate the APU (Task 1-36).
12. Set switch (1) to MOTOR. Wait until engine starts to rotate. After engine has rotated slowly for **2 minutes**, set switch (1) to OFF.
13. Shut down the APU (Task 1-36).

INSPECT**NO. 2 ENGINE**

14. Repeat steps 4 thru 6 for No. 2 engine.
15. Set ENGINE 2 start switch (2) on cockpit START panel (3) to MOTOR. After **5 minutes** set switch (2) to OFF.
16. Shut down the APU (Task 1-36).
17. Repeat steps 9 and 10 for No. 2 engine.
18. Operate the APU (Task 1-36).
19. Set switch (2) to MOTOR. Wait until engine starts to rotate. After engine has rotated slowly for **2 minutes** set switch (2) to OFF.
20. Shut down the APU (Task 1-36).

INSPECT**FOLLOW-ON MAINTENANCE:**

- Service utility reservoir (Task 1-59 or 1-62).
- Disconnect battery (Task 1-39).
- Close engine access covers (Task 4-50).

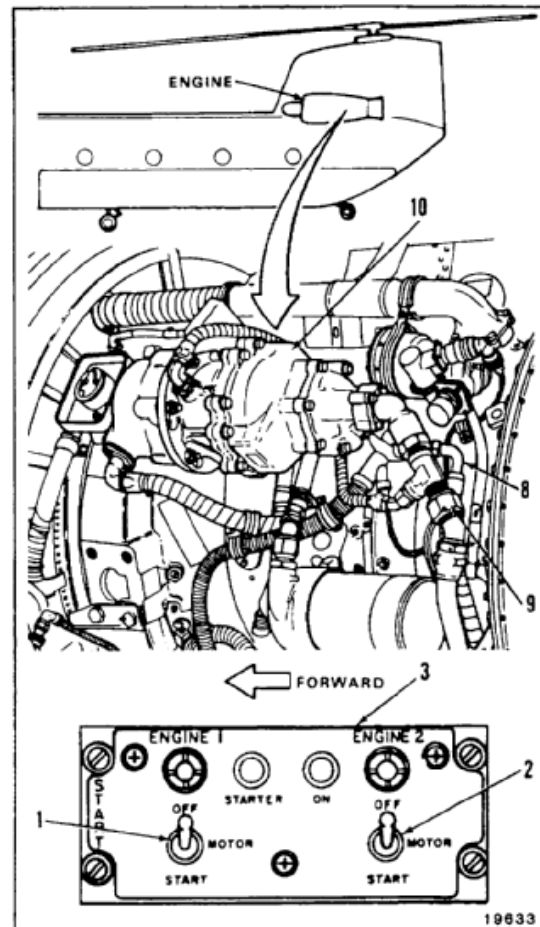

END OF TASK

7-1288

7-347.1 BLEEDING ENGINE START HYDRAULIC SYSTEMS (WITHOUT EXTERNAL POWER)

7-347.1

INITIAL SETUP

General Safety Instructions:

Applicable Configurations:

With **74**

Tools:

Hydraulic Repairer's Tool Kit, NSN 5780-00-323-4891
 Container, 2 Quart
 Reducers, MS21916D12-10

Materials:

Cloths (E120)
 Gloves (E184.1)

Personnel Required:

Aircraft Pneudraulics Repairer
 Inspector

References:

Task 1-36

Equipment Condition:

Battery Connected (Task 1-39)
 Electrical Power On
 Hydraulic Power Off
 Engine Access Covers Open (Task 4-49)

WARNING

Hydraulic fluid (E199) is toxic. It can irritate skin and cause burns. Avoid inhaling. Use only with adequate ventilation. Avoid contact with skin, eyes, or clothing. In case of contact, immediately flush skin or eyes with water for at least **15 minutes**. Get medical attention for eyes.

WARNING

Hydraulic fluid ejected under pressure can cause injury to personnel. Hydraulic fluid sprayed into the air is a fire hazard.

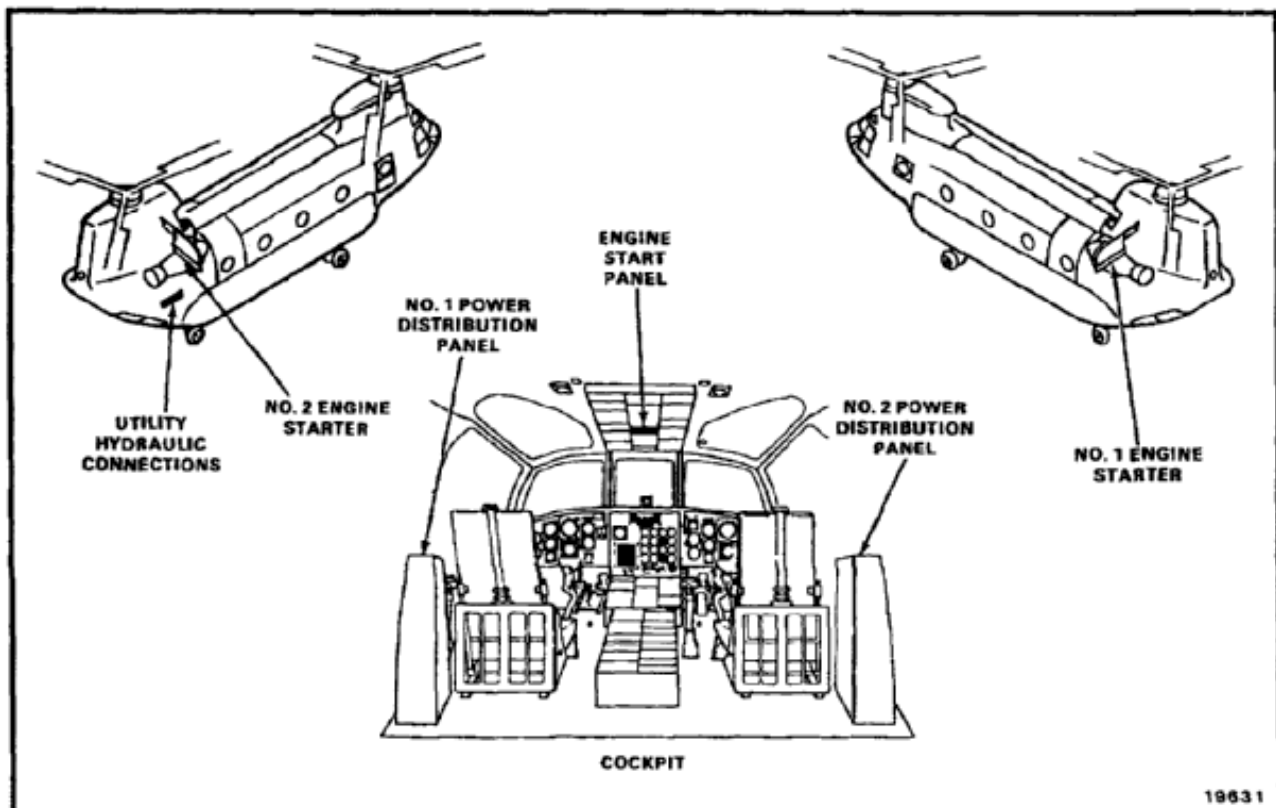

1. In cockpit, place ENG START switch on FADEC panel (3) to center position between (1 and 2).
2. Pull out ENGINE NO. 1 START & IGN circuit breaker (4) on No. 1 PDP (5) to OFF position.
3. Pull out ENGINE NO. 2 START & IGN circuit breaker (6) on No. 2 PDP (7) to OFF position.

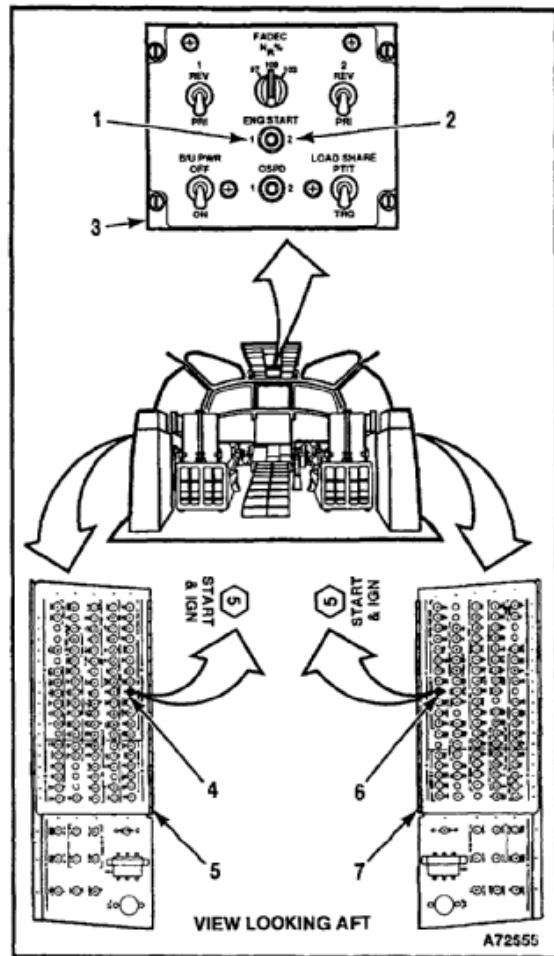

7-347.1 BLEEDING ENGINE START HYDRAULIC SYSTEMS (WITHOUT EXTERNAL POWER) (Continued)

7-347.1

NO. 1 ENGINE

4. Disconnect pressure line (8) and return line (9) from engine starter (10). Use a container and cloths (E120) to catch spilled fluid. Wear gloves (E184.1).
5. Connect pressure line (8) to return line (9) with reducer.
6. Operate the APU (Task 1-36).
7. Set ENG START switch on cockpit FADEC panel (3) to position 1 (1). After **5 minutes** set ENG START switch to center position.
8. Shut down the APU (Task 1-36).
9. At engine, disconnect pressure line (8) from return line (9).
10. Connect pressure line (8) and return line (9) to engine starter (10).
11. Operate the APU (Task 1-36).
12. Set ENG START switch to position 1 (1). Wait until engine starts to rotate. After engine has rotated slowly for **2 minutes**, set ENG START switch to center position.
13. Shut down the APU (Task 1-36).

INSPECT
NO. 2 ENGINE

14. Repeat steps 4 thru 6 for No. 2 engine.
15. Set ENG START switch on cockpit FADEC panel (3) to position 2 (2). After **5 minutes** set ENG START switch to center position.
16. Shut down the APU (Task 1-36).
17. Repeat steps 9 and 10 for No. 2 engine.
18. Operate the APU (Task 1-36).
19. Set ENG START switch to position 2 (2). Wait until engine starts to rotate. After engine has rotated slowly for **2 minutes**, set ENG START switch to center position.
20. Shut down the APU (Task 1-36).

INSPECT
FOLLOW-ON MAINTENANCE:

- Service utility reservoir (Task 1-59 or 1-62).
- Disconnect battery (Task 1-39).
- Close engine access covers (Task 4-50).

END OF TASK

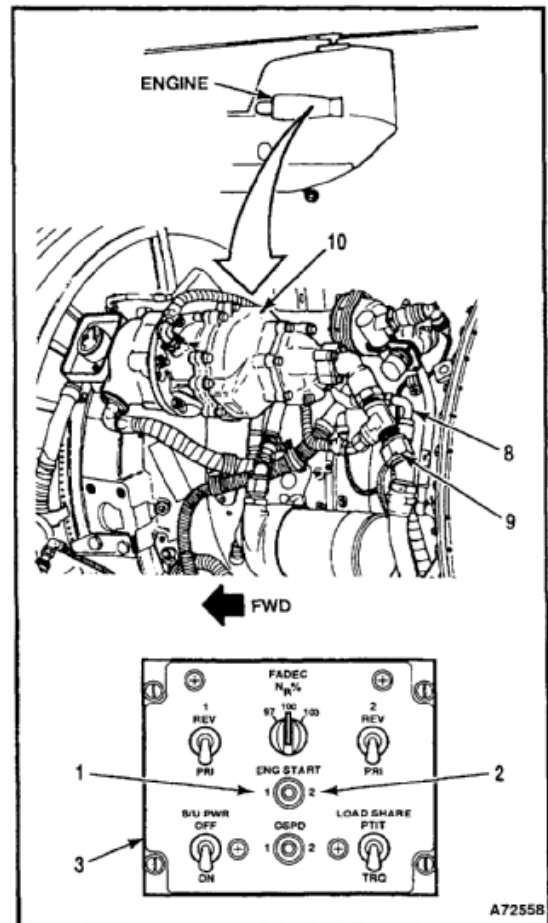

INITIAL SETUP

General Safety Instructions:

Applicable Configurations:

All

Tools:

Hydraulic Repairer's Tool Kit, NSN 5180-00-323-4891
 Container, 14 Quart
 Workstand

Materials:

Cloths (E120)
 Hydraulic Fluid (E199)
 Gloves (E18)
 Bleeder Hose (Tubing) (E428)

Personnel Required:

Aircraft Pneudraulics Repairer (2)

Equipment Condition:

Battery Connected (Task 1-39)
 Electrical Power On
 Hydraulic Power Off
 Cargo Ramp Fully Down (TM 55-1520-240-T)
 Ramp Switch Set to ON (TM 55-1520-240-T)

WARNING

Hydraulic fluid (E199) is toxic. It can irritate skin and cause burns. Avoid inhaling. Use only with adequate ventilation. Avoid contact with skin, eyes, or clothing. In case of contact, immediately flush skin or eyes with water for at least **15 minutes**. Get medical attention for eyes.

WARNING

Hydraulic fluid ejected under pressure can cause injury to personnel. Hydraulic fluid sprayed into the air is a fire hazard.

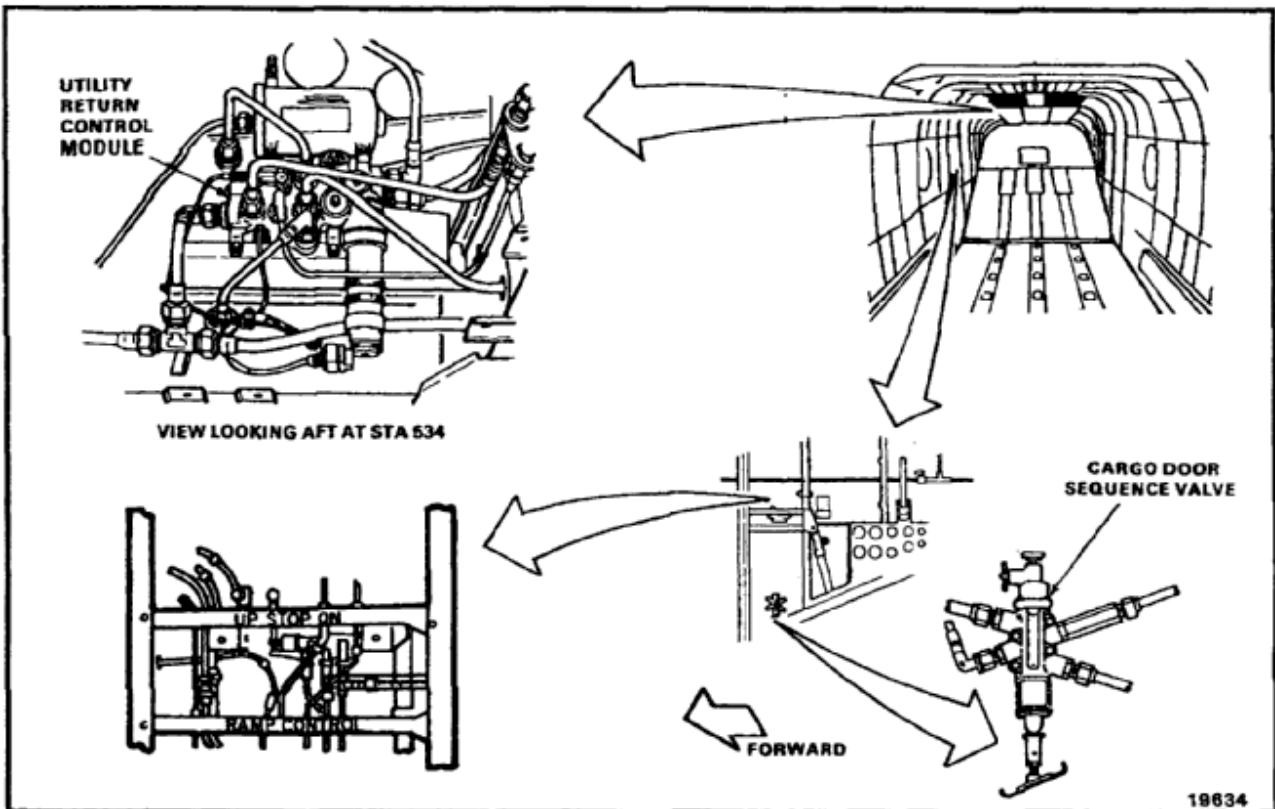

19634

7-348 BLEED CARGO RAMP AND DOOR HYDRAULIC SYSTEM (WITHOUT EXTERNAL POWER) (Continued)

7-348

1. Push down and hold manual override knob (1) on sequence valve (2). Turn lockpin handle (3) **90°** to lock knob. If knob does not lock, turn rod end (4) clockwise until knob locks.
2. Screw locknut (5) down as far as it will go.
3. Screw rod end (4) down as far as it will go. Check that there is clearance between rod and cartridge (6).

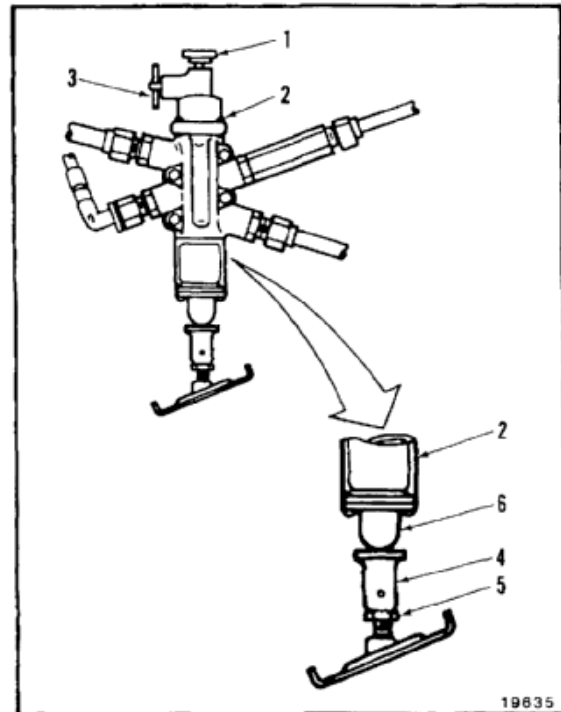

4. Remove cap (7) from bleed valve (8) on transfer cylinder (9).
5. Connect bleed hose (10) to valve (8).



Container and hydraulic fluid (E199) must be clean; otherwise, components can malfunction.

6. Fill container (11) with about **1 gallon** of hydraulic fluid (E199). Wear gloves (E186).
7. Put open end of hose (10) below fluid level in container (11).
8. Open valve (8). Push piston rod (12) fully in. Make sure bleed hose (10) is submerged in fluid.
9. Operate the APU (Task 1-36).

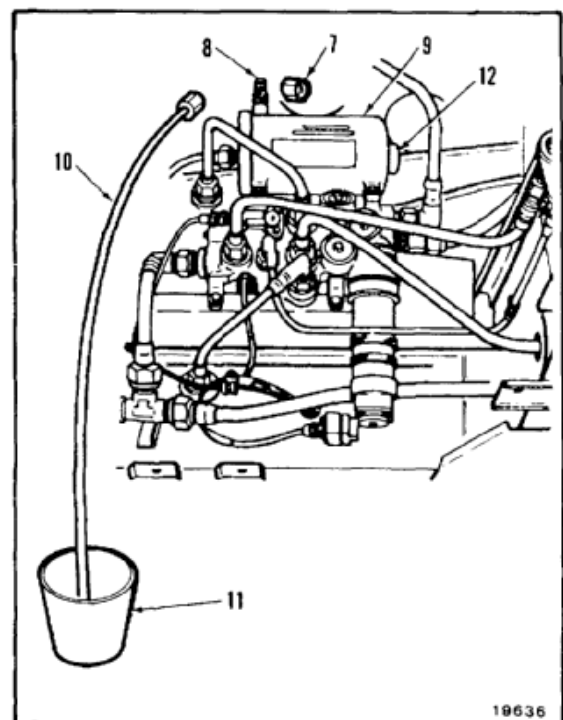

10. Set ramp control handle (13) to UP. Close the ramp fully.



If a lot of air is in the circuit, the ramp may drop fast enough to be damaged as it strikes the ground. To prevent damage, place padding on the ground in the contact area.

11. Move control handle (13) to DN. Lower the ramp fully. Keep hose (10) submerged as fluid is drawn from container.

NOTE

As air is removed from the system, the fluid level in the container will go down.

12. Repeat steps 10 and 11 until no air comes through hose (10). Raise the ramp to full up.

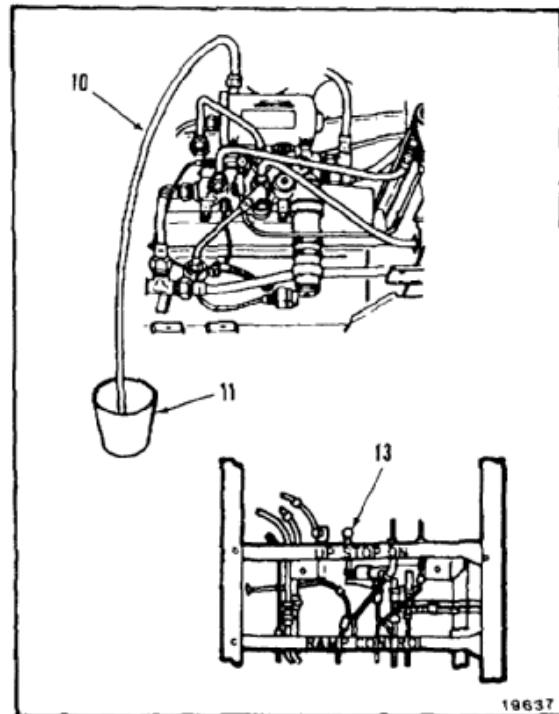

13. Adjust sequence valve (2) as follows:



Manual override knob (1) must remain locked down during adjustment. Otherwise, the ramp seal will be damaged.

- a. Screw rod end (4) up against plunger (6) until plunger bottoms in valve (2). Plunger travel shall be about **0.4 inch**.
- b. Screw rod end (4) down **3-1/2 turns (0.15 inch)**. Tighten locknut (5) against rod end.
- c. Check that thread is visible through inspection hole (14) in rod end (4). Check that rod end can be moved vertically about **0.15 inch**.

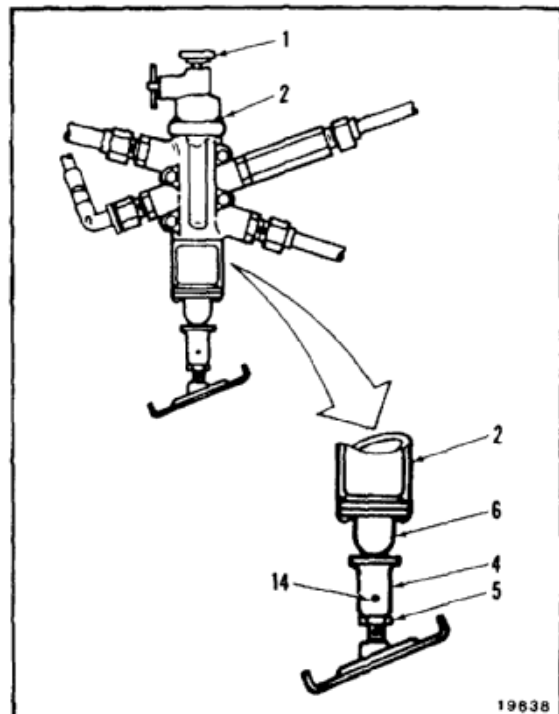

7-348 BLEED CARGO RAMP AND DOOR HYDRAULIC SYSTEM (WITHOUT EXTERNAL POWER) (Continued)

7-348

14. Set ramp control handle (13) to DN. The ramp shall lower fully.
15. Turn lockpin handle (3) on sequence valve (2) to release manual override knob (1).
16. Set handle (13) to UP. The ramp shall rise and pause; the door shall extend fully; then the ramp shall fully raise.
17. Repeat steps 14 and 16 until no more air comes through hose (10) at transfer cylinder (9).
18. Lower the ramp. Close bleed valve (8) on transfer cylinder (9) and raise the ramp.
19. Check extension of piston rod (12). Extension shall be about **4.2 inches**. If less than **4.0 inches**, repeat bleed procedure.

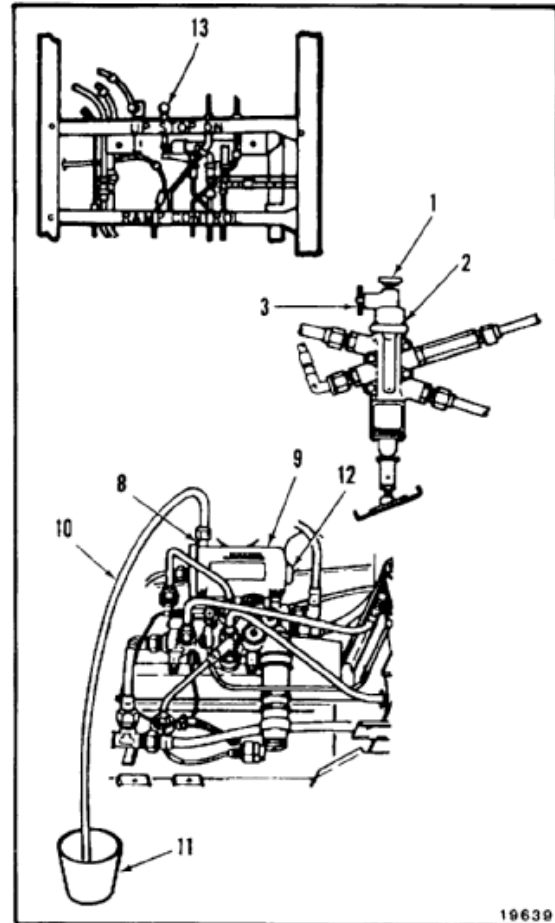

20. Lower the ramp. Check that piston rod (12) retracts.
21. Remove bleed hose (10) from valve (8). Install cap (7).
22. Shut down the APU.

FOLLOW-ON MAINTENANCE:

Close cargo ramp (TM 55-1520-240-T).
 Disconnect battery (Task 1-39).
 Set ramp switch to OFF.

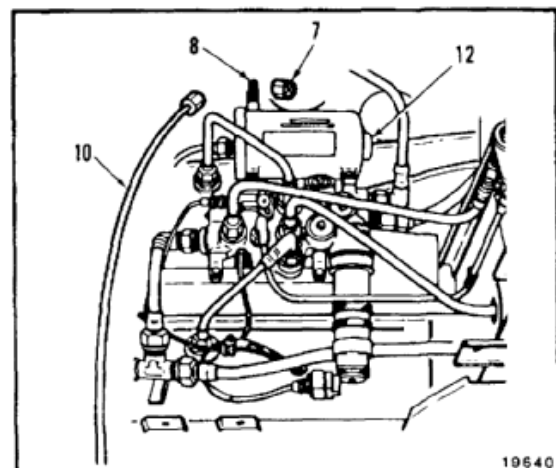

END OF TASK

INITIAL SETUP

Applicable Configurations:

All

Tools:

Aircraft Mechanic's Tool Kit, NSN 5180-00-323-4692
 Handle, Removable (SK33086-1) (APP E-320)
 Torque Screwdriver, 0 to 50 Inch-Pounds
 Allen Wrench, 5/32 Inch

Materials:

Cloths (E120)
 Gloves (E184.1)
 Hydraulic Fluid (E199)

Personnel Required:

Medium Helicopter Repairer
 Inspector

Equipment Condition:

Battery Disconnected (Chapter 1)
 Electrical Power Off
 Hydraulic Power Off
 Power Drain No. 1 Flight Control Hydraulic System
 Reservoir (Chapter 1)
 Task 7-33
 Task 7-113
 Task 7-135.1
 Task 7-156
 Task 7-194
 Task 7-212

References:

TM 55-1520-240-23P

General Safety Instructions:**WARNING**

Hydraulic fluid (E199) is toxic. It can irritate skin and cause burns. Avoid inhaling. Use only with adequate ventilation. Avoid contact with skin, eyes, or clothing. In case of contact, immediately flush skin or eyes with water for at least **15 minutes**. Get medical attention for eyes.

WARNING

Hydraulic fluid ejected under pressure can cause injury to personnel. Hydraulic fluid sprayed into the air is a fire hazard.

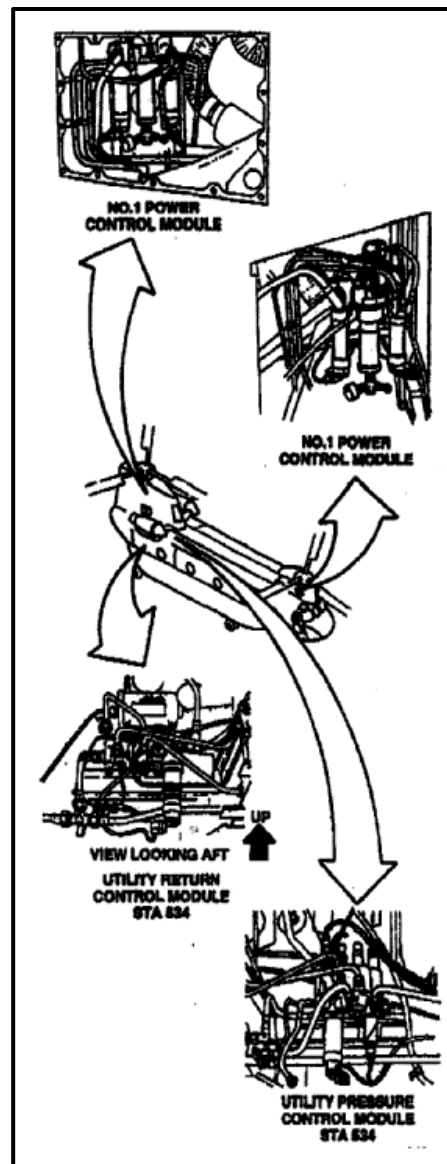

CAUTION

When removing and installing the shut-off diaphragm compressor, make sure that it is not cross-threaded in the filter bowl port, or component damage may occur.

NOTE

The procedure to replace all module shutoff diaphragms is the same. Power control module is shown.

If the diaphragm compressor and handle (APP E-320) are not available, a **3/16 by 1/2 inch** drive deep well socket may be used to compress the diaphragm is under strong spring pressure and parts are easily damaged.

REMOVE SHUTOFF DIAPHRAGM

1. Install the diaphragm compressor (1) as follows:
 - a. Carefully screw the diaphragm compressor (1) into the filter bowl port (2). Hand tighten as far as possible.
 - b. Insert the pins of the removable handle (3) into the holes in the compressor (1).
 - c. Using handle (3), screw compressor (1) into port (2) until it is fully seated.
 - d. Remove handle (3).
2. Using a **5/32 inch** Allen wrench through hole in compressor, remove diaphragm retainer screw (4) and bushing (5) from port (2).

CAUTION

Diaphragm is under strong spring pressure. Exercise care when removing it.

3. Carefully unscrew compressor (1) from port (2). Use handle (3).
4. Remove shutoff diaphragm (6) and spring (7) from port (2).
5. Remove two packings (8 and 9) from inner bore of diaphragm (6). See view A.
6. Remove packing (10) and retainer (11) from inner groove in port (2). See view A.

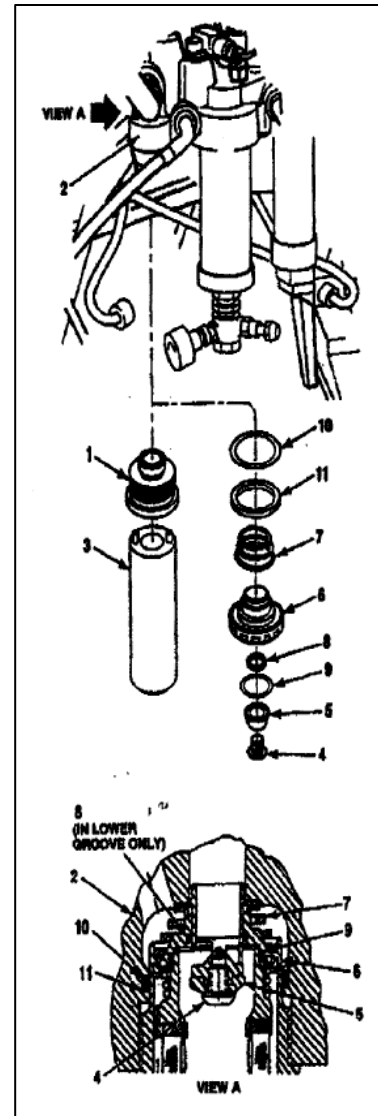

INSTALL SHUTOFF DIAPHRAGM

7. Clean diaphragm (6), spring (7), and inner bore of port (2). Use cloths (E120).



When installing packings and retainer, make sure that they are installed on top of retainer. See view A.

8. Lubricate retainer (11) and packing (10) with hydraulic fluid (E199). Wear gloves (E184.1).
9. Install packing (10) and retainer (11) in inner groove of port (2). Packing is installed on top of retainer. See view A.
10. Lubricate packings (8 and 9) with hydraulic fluid (E199). Wear gloves (E184.1).
11. Install packings (8 and 9) in inner bore of diaphragm (6) as shown in view A.
12. Position spring (7) on diaphragm (6) with large end against diaphragm.



When installing diaphragm, spring pressure must be overcome. Make sure diaphragm is not cross-threaded. Be careful not to damage packing or retainer.

13. Carefully install spring (7) and diaphragm (6) in port (2). Use compressor (1) to install diaphragm.
14. Use handle (3) and screw compressor (1) into port (2) until compressor is fully seated. Remove handle.

NOTE

Bushing is installed with flat side of bushing against diaphragm. Make sure the packing is properly seated and not pinched.

15. Install bushing (5) and retainer screw (4). Use Allen wrench.
16. Torque screw (4) to **30 to 35 inch-pounds**.
17. Remove compressor (1) from port (2). Use handle (3).

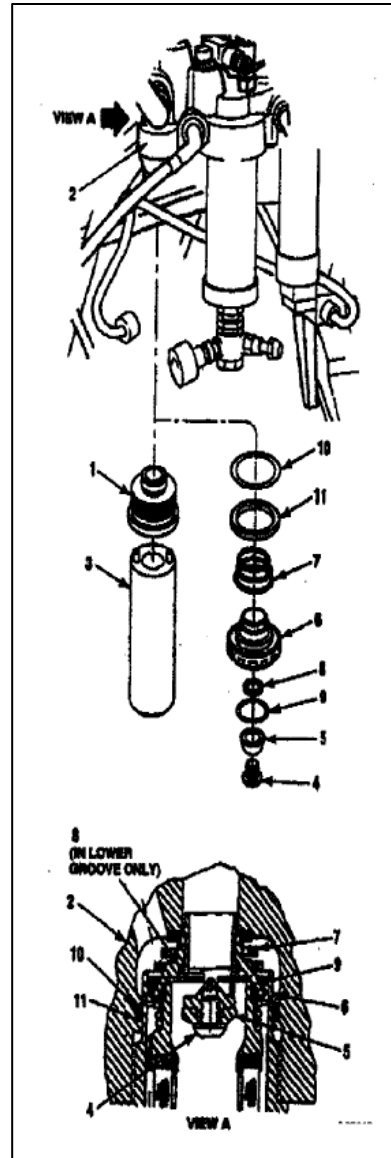

INSPECT***FOLLOW-ON MAINTENANCE:***

- Install No. 1 or No. 2 power control module filter element (Task 7-34).
- Install pressure control module filter (Task 7-157).
- Install utility return control module filter element (Task 7-195).
- Service utility hydraulic reservoir (Chapter 1).
- Perform operational check of system (TM 55-1520-240-T).
- Install utility reservoir cooler (Task 7-218).
- Bleed utility reservoir/cooler, APU pump/motor and pump (Task 7-336).
- Power drain No. 1 flight control hydraulic system reservoir (Chapter 1).

END OF TASK

By Order of the Secretary of the Army:

Official:

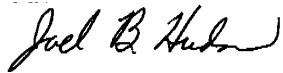

JOEL B. HUDSON
Administrative Assistant to the
Secretary of the Army
0220710

ERIC K. SHINSEKI
General, United States Army
Chief of Staff

DISTRIBUTION:

To be distributed in accordance with Initial Distribution Number (IDN) 311199, requirements for TM 55-1520-240-23-6.

These are the instructions for sending an electronic 2028

The following format must be used if submitting an electronic 2028. The subject line must be exactly the same and all fields must be included; however only the following fields are mandatory: 1, 3, 4, 5, 6, 7, 8, 9, 10, 13, 15, 16, 17, and 27.

From: "Whomever" <whomever@wherever.army.mil>

To: 2028@redstone.army.mil

Subject: DA Form 2028

1. **From:** Joe Smith
2. **Unit:** home
3. **Address:** 4300 Park
4. **City:** Hometown
5. **St:** MO
6. **Zip:** 77777
7. **Date Sent:** 19-OCT-93
8. **Pub no:** 55-2840-229-23
9. **Pub Title:** TM
10. **Publication Date:** 04-JUL-85
11. **Change Number:** 7
12. **Submitter Rank:** MSG
13. **Submitter FName:** Joe
14. **Submitter MName:** T
15. **Submitter LName:** Smith
16. **Submitter Phone:** 123-123-1234
17. **Problem:** 1
18. **Page:** 2
19. **Paragraph:** 3
20. **Line:** 4
21. **NSN:** 5
22. **Reference:** 6
23. **Figure:** 7
24. **Table:** 8
25. **Item:** 9
26. **Total:** 123
27. **Text:**

This is the text for the problem below line 27.

RECOMMENDED CHANGES TO PUBLICATIONS AND BLANK FORMS <small>For use of this form, see AR 25-30; the proponent agency is ODISC4.</small>	Use Part II (<i>reverse</i>) for Repair Parts and Special Tool Lists (RPSTL) and Supply Catalogs/Supply Manuals (SC/SM)	DATE <h2 style="text-align: center;">8/30/02</h2>
----------------------------------------------------------------------------------------------------------------------------------------------------------	---------------------------------------------------------------------------------------------------------------------------	----------------------------------------------------------

TO: (<i>Forward to proponent of publication or form</i>)(<i>Include ZIP Code</i>) Commander, U.S. Army Aviation and Missile Command ATTN: AMSAM-MMC-MA-NP Redstone Arsenal, 35898	FROM: (<i>Activity and location</i>)(<i>Include ZIP Code</i>) MSG, Jane Q. Doe 1234 Any Street Nowhere Town, AL 34565
------------------------------------------------------------------------------------------------------------------------------------------------------------------------------------------------	------------------------------------------------------------------------------------------------------------------------------------

PART 1 - ALL PUBLICATIONS (EXCEPT RPSTL AND SC/SM) AND BLANK FORMS

PUBLICATION/FORM NUMBER <h3 style="text-align: center;">TM 9-1005-433-24</h3>	DATE <h3 style="text-align: center;">16 Sep 2002</h3>	TITLE Organizational, Direct Support, And General Support Maintenance Manual for Machine Gun, .50 Caliber M3P and M3P Machine Gun Electrical Test Set Used On Avenger Air Defense Weapon System
----------------------------------------------------------------------------------	----------------------------------------------------------	-------------------------------------------------------------------------------------------------------------------------------------------------------------------------------------------------

ITEM NO.	PAGE NO.	PARA-GRAPH	LINE NO. *	FIGURE NO.	TABLE NO.	RECOMMENDED CHANGES AND REASON
1	WP0005 PG 3		2			Test or Corrective Action column should identify a different WP number.
<div style="border: 2px solid black; padding: 20px; font-size: 48px; font-weight: bold; letter-spacing: 0.5em;"> SAMPLE </div>						

* Reference to line numbers within the paragraph or subparagraph.

TYPED NAME, GRADE OR TITLE <h3 style="text-align: center;">MSG, Jane Q. Doe, SFC</h3>	TELEPHONE EXCHANGE/ AUTOVON, PLUS EXTENSION <h3 style="text-align: center;">788-1234</h3>	SIGNATURE
----------------------------------------------------------------------------------------------	-----------------------------------------------------------------------------------------------------	-----------

TO: (Forward direct to addressee listed in publication) Commander, U.S. Army Aviation and Missile Command ATTN: AMSAM-MMC-MA-NP Redstone Arsenal, 35898	FROM: (Activity and location) (Include ZIP Code) MSG, Jane Q. Doe 1234 Any Street Nowhere Town, AL 34565	DATE 8/30/02
-------------------------------------------------------------------------------------------------------------------------------------------------------------------------	--------------------------------------------------------------------------------------------------------------------------	------------------------

PART II - REPAIR PARTS AND SPECIAL TOOL LISTS AND SUPPLY CATALOGS/SUPPLY MANUALS

PUBLICATION NUMBER			DATE	TITLE				
PAGE NO.	COLM NO.	LINE NO.	NATIONAL STOCK NUMBER	REFERENCE NO.	FIGURE NO.	ITEM NO.	TOTAL NO. OF MAJOR ITEMS SUPPORTED	RECOMMENDED ACTION
SAMPLE								

PART III - REMARKS (Any general remarks or recommendations, or suggestions for improvement of publications and blank forms. Additional blank sheets may be used if more space is needed.)

TYPED NAME, GRADE OR TITLE MSG, Jane Q. Doe, SFC	TELEPHONE EXCHANGE/AUTOVON, PLUS EXTENSION 788-1234	SIGNATURE
------------------------------------------------------------	---------------------------------------------------------------	-----------

RECOMMENDED CHANGES TO PUBLICATIONS AND BLANK FORMS <small>For use of this form, see AR 25-30; the proponent agency is ODISC4.</small>	Use Part II (reverse) for Repair Parts and Special Tool Lists (RPSTL) and Supply Catalogs/Supply Manuals (SC/SM)	DATE
----------------------------------------------------------------------------------------------------------------------------------------------------------	------------------------------------------------------------------------------------------------------------------	------

TO: (Forward to proponent of publication or form)(Include ZIP Code)	FROM: (Activity and location)(Include ZIP Code)
---------------------------------------------------------------------	-------------------------------------------------

PART 1 - ALL PUBLICATIONS (EXCEPT RPSTL AND SC/SM) AND BLANK FORMS

PUBLICATION/FORM NUMBER TM 9-1005-433-24	DATE 16 Sep 2002	TITLE Organizational, Direct Support, And General Support Maintenance Manual for Machine Gun, .50 Caliber M3P and M3P Machine Gun Electrical Test Set Used On Avenger Air Defense Weapon System
----------------------------------------------------	----------------------------	-------------------------------------------------------------------------------------------------------------------------------------------------------------------------------------------------

ITEM NO.	PAGE NO.	PARA-GRAPH	LINE NO. *	FIGURE NO.	TABLE NO.	RECOMMENDED CHANGES AND REASON

** Reference to line numbers within the paragraph or subparagraph.*

TYPED NAME, GRADE OR TITLE	TELEPHONE EXCHANGE/ AUTOVON, PLUS EXTENSION	SIGNATURE
----------------------------	------------------------------------------------	-----------

TO: (Forward direct to addressee listed in publication)	FROM: (Activity and location) (Include ZIP Code)	DATE
----------------------------------------------------------------	---------------------------------------------------------	-------------

PART II - REPAIR PARTS AND SPECIAL TOOL LISTS AND SUPPLY CATALOGS/SUPPLY MANUALS

PUBLICATION NUMBER	DATE	TITLE
---------------------------	-------------	--------------

PAGE NO.	COLM NO.	LINE NO.	NATIONAL STOCK NUMBER	REFERENCE NO.	FIGURE NO.	ITEM NO.	TOTAL NO. OF MAJOR ITEMS SUPPORTED	RECOMMENDED ACTION

PART III - REMARKS (Any general remarks or recommendations, or suggestions for improvement of publications and blank forms. Additional blank sheets may be used if more space is needed.)

TYPED NAME, GRADE OR TITLE	TELEPHONE EXCHANGE/AUTOVON, PLUS EXTENSION	SIGNATURE
----------------------------	--------------------------------------------	-----------

The Metric System and Equivalents

Linear Measure

1 centimeter = 10 millimeters = .39 inch
 1 decimeter = 10 centimeters = 3.94 inches
 1 meter = 10 decimeters = 39.37 inches
 1 dekameter = 10 meters = 32.8 feet
 1 hectometer = 10 dekameters = 328.08 feet
 1 kilometer = 10 hectometers = 3,280.8 feet

Weights

1 centigram = 10 milligrams = .15 grain
 1 decigram = 10 centigrams = 1.54 grains
 1 gram = 10 decigrams = .035 ounce
 1 decagram = 10 grams = .35 ounce
 1 hectogram = 10 decagrams = 3.52 ounces
 1 kilogram = 10 hectograms = 2.2 pounds
 1 quintal = 100 kilograms = 220.46 pounds
 1 metric ton = 10 quintals = 1.1 short tons

Liquid Measure

1 centiliter = 10 milliliters = .34 fl. ounce
 1 deciliter = 10 centiliters = 3.38 fl. ounces
 1 liter = 10 deciliters = 33.81 fl. ounces
 1 dekaliter = 10 liters = 2.64 gallons
 1 hectoliter = 10 dekaliters = 26.42 gallons
 1 kiloliter = 10 hectoliters = 264.18 gallons

Square Measure

1 sq. centimeter = 100 sq. millimeters = .155 sq. inch
 1 sq. decimeter = 100 sq. centimeters = 15.5 sq. inches
 1 sq. meter (centare) = 100 sq. decimeters = 10.76 sq. feet
 1 sq. dekameter (are) = 100 sq. meters = 1,076.4 sq. feet
 1 sq. hectometer (hectare) = 100 sq. dekameters = 2.47 acres
 1 sq. kilometer = 100 sq. hectometers = .386 sq. mile

Cubic Measure

1 cu. centimeter = 1000 cu. millimeters = .06 cu. inch
 1 cu. decimeter = 1000 cu. centimeters = 61.02 cu. inches
 1 cu. meter = 1000 cu. decimeters = 35.31 cu. feet

Approximate Conversion Factors

<i>To change</i>	<i>To</i>	<i>Multiply by</i>	<i>To change</i>	<i>To</i>	<i>Multiply by</i>
inches	centimeters	2.540	ounce-inches	Newton-meters	.007062
feet	meters	.305	centimeters	inches	.394
yards	meters	.914	meters	feet	3.280
miles	kilometers	1.609	meters	yards	1.094
square inches	square centimeters	6.451	kilometers	miles	.621
square feet	square meters	.093	square centimeters	square inches	.155
square yards	square meters	.836	square meters	square feet	10.764
square miles	square kilometers	2.590	square meters	square yards	1.196
acres	square hectometers	.405	square kilometers	square miles	.386
cubic feet	cubic meters	.028	square hectometers	acres	2.471
cubic yards	cubic meters	.765	cubic meters	cubic feet	35.315
fluid ounces	milliliters	29.573	cubic meters	cubic yards	1.308
pints	liters	.473	milliliters	fluid ounces	.034
quarts	liters	.946	liters	pints	2.113
gallons	liters	3.785	liters	quarts	1.057
ounces	grams	28.349	liters	gallons	.264
pounds	kilograms	.454	grams	ounces	.035
short tons	metric tons	.907	kilograms	pounds	2.205
pound-feet	Newton-meters	1.356	metric tons	short tons	1.102
pound-inches	Newton-meters	.11296			

Temperature (Exact)

F	Fahrenheit temperature	5/9 (after subtracting 32)	Celsius temperature	C
---	---------------------------	-------------------------------	------------------------	---

