

TECHNICAL MANUAL

**AVIATION UNIT AND AVIATION
INTERMEDIATE MAINTENANCE MANUAL**

CH-47D HELICOPTER

This manual together with TM 55-1520-240-23-1, TM 55-1520-240-23-2, TM 55-1520-240-23-3, TM 55-1520-240-23-4, TM 55-1520-240-23-5, TM 55-1520-240-23-6, TM 55-1520-240-23-7, TM 55-1520-240-23-9, TM 55-1520-240-23-10, TM 55-1520-240-23-11, supersedes TM 55-1520-240-23-1, TM 55-1520-240-23-2, TM 55-1520-240-23-3, TM 55-1520-240-23-4, TM 55-1520-240-23-5, TM 55-1520-240-23-7, TM 55-1520-240-23-8, TM 55-1520-240-23-9, TM 55-1520-240-23-10, 10 May 1983, and TM 55-1520-240-23-6, 6 May 1983, including all changes.

DISTRIBUTION STATEMENT A: Approved for public release; distribution is unlimited.

**CHANGE
NO. 1**

**HEADQUARTERS
DEPARTMENT OF THE ARMY
WASHINGTON, D.C., 30 SEPTEMBER 2003**

Aviation Unit and Aviation Intermediate
Maintenance Manual

CH-47D HELICOPTER

DISTRIBUTION STATEMENT A: Approved for public release; distribution is unlimited.

TM 55-1520-240-23-8, 19 September 2002, is changed as follows:

1. Remove and insert pages as indicated below. New or changed text material is indicated by a vertical bar in the margin. An illustration change is indicated by a miniature pointing hand.

Remove pages

A/(B blank)
i/(ii blank)
10-387 and 10-388

Insert Pages

A/(B blank)
i/(ii blank)
10-387 and 10-388

2. Retain this sheet in front of the manual for reference purposes.

TM 55-1520-240-23-8
C1

By Order of the Secretary of the Army:

Official:

PETER J. SCHOOMAKER
General, United States Army
Chief of Staff

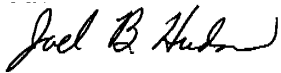

JOEL B. HUDSON
Administrative Assistant to the
Secretary of the Army
0320905

DISTRIBUTION:

To be distributed in accordance with Initial Distribution Number (IDN) 311199, requirements for TM 55-1520-240-23-8.

WARNING AND FIRST AID DATA

For artificial respiration and other first aid data, refer to FM 21-11.

Personnel performing instructions involving operations, procedures, and practices which are included or implied in this technical manual shall observe the following instructions. Disregard of these warnings and precautionary information can cause serious injury, illness, death, or an aborted mission.

**WARNING**

An operating procedure, practice, etc., which if not correctly followed could result in personal injury or loss of life.

**CAUTION**

An operation procedure, practice, etc., which if not strictly observed, could result in damage to or destruction of equipment.

NOTE

An operating procedure, condition, etc., which is essential to highlight.

**WARNING**

Cleaning Solvents

Those areas of skin and clothing that come in contact with cleaning solvents should be thoroughly washed immediately.

Saturated clothing should be removed immediately.

Areas in which cleaning solvents are used should be adequately ventilated to keep vapors to a minimum.

If cleaning solvents contact the eyes, nose, or ears, flush them with generous quantities of water, and then seek medical attention immediately.

**WARNING**

Electrical and Electronic Equipment Maintenance

Do not wear rings, watches, or metal jewelry when working around electrical equipment. Serious burns can result.

Be careful when working on 150 and 300 vdc circuits and on ac generator 115 and 200 vac outputs. Serious burns can result.

WARNING

Dangerous Static Charges

Ground the helicopter during parking, fueling, or defueling. Sparks can cause fuel vapor to ignite.

WARNING

Dangerous Voltages at Antenna Terminals

Be careful when working near antenna or antenna terminals. Radio frequency (rf) voltages exist at these points when transmitters are operating. Contact with radiating antennas can cause serious rf burns.

WARNING

Poisonous Carbon Monoxide Fumes

Toxic carbon monoxide fumes may be present inside the helicopter whenever engines or APU are operating with cargo ramp open. Ventilate the cockpit.

WARNING

Corrosive Battery Electrolyte (Potassium Hydroxide)

The electrolyte used in nickel-cadmium batteries contains potassium hydroxide which is a caustic substance.

Contact with skin or eyes will cause burns.

Use rubber gloves, rubber apron, and protective eye covering or face shield when handling battery.

If personal contact with electrolyte occurs, flush immediately with large amounts of only clean water. Get medical attention immediately.

WARNING

Explosive Battery Hazard

Before removing or installing battery, make sure battery switch is OFF and battery has cooled down if overheated.

Connecting or disconnecting battery connector while battery is under load may cause explosion or electrical arcing resulting in injury to personnel.

WARNING

Electrolyte Contamination

Separate nickel-cadmium batteries and lead-acid type batteries as far as possible from each other.

Do not let anything associated with a lead-acid battery, including air, come in contact with a nickel-cadmium battery or its electrolyte. Sulfuric acid fumes from a lead-acid battery could result in damage to a nickel-cadmium battery leading to battery failure and a hazard to personnel.

Do not use same tools or protective clothing for both types of batteries.

If sulfuric acid has been somehow mixed with electrolyte in the battery, the upper areas of the battery cells will appear green in color indicating battery failure or damage and potential danger to personnel unless replaced.

WARNING

Acids and Alkalines

Do not add water to acid. A violent action will result. Add acid to water in small quantities.

Rust stripper is an alkaline solution.

Avoid skin contact. Wear protective clothing. Wash thoroughly after using.

WARNING

Windshield Rain Repellent

Do not let windshield rain repellent contact open flame. Deadly hydrogen fluoride gas could be generated.

Wash hands with soap and water after handling repellent.

WARNING

Antiseize Compounds

Some antiseize compounds are irritants. Avoid inhaling fumes and contact with skin.

Wear protective clothing. Wash thoroughly after using.

WARNING

Paints, Varnishes, Dopes, Thinners, and Lubricants

These materials are generally highly flammable and may be irritants. Work in a well-ventilated area away from open flames.

Avoid inhaling fumes and prolonged contact with skin. Wash thoroughly after using.

WARNING

Epoxy Resins, Cements, and Adhesives

These materials may contain toxic or irritating substances. They may also be flammable. Work in a well-ventilated area away from open flames.

Wear protective clothing. Avoid contact with skin. Wash thoroughly after using.

WARNING

Radiation Hazard

Some instruments contain radioactive material. Do not try to disassemble these instruments. They present no radiation hazard unless seal is broken.

If you think seal is broken, do not remove instrument from helicopter before consulting Base Radioactive Protection Officer (AR 40-15).

Use a beta-gamma radiac meter AN/PDR-27 or equivalent to determine if instrument contains radioactive material (radium).

WARNING

Fire Extinguishing Agents

Monobromotrifluoromethane (CF_3Br) is highly volatile but is not easily detected by smell. It is not toxic, but reduces oxygen available for proper breathing.

If liquid CF_3Br contacts skin, it can cause frostbite or low temperature burns.

If agent touches eyes or skin, immediately flush affected area with running water. Get medical attention.

WARNING**Noise**

Sound pressure levels in this helicopter during some operating conditions exceed the Surgeon General's hearing conservation criteria (TB MED251).

Hearing protection devices, such as aviator helmet or ear plugs, shall be worn by all personnel in and around the helicopter during operation.

WARNING**FOD**

Make sure area is clear of foreign objects before closing access doors, panels, and fairings.

If area is not clear, damage to components or systems could result in personal injury or death.

WARNING**JP-4/JP-5/JP-8 Fuel MIL-T-5624**

Fuel is flammable. Do not use near welding areas, open flames, or on very hot surfaces.

Use only with adequate ventilation.

Avoid prolonged or repeated contact with skin. Prolonged contact may cause drying and irritation of skin.

Remove saturated clothing immediately.

Do not smoke when handling fuel.

Do not take internally.

Store in approved, metal safety containers.

WARNING**Lubricating Oils MIL-L-23699 or MIL-L-7808**

If oil is decomposed by heat, toxic gases are released.

Prolonged contact with liquid or mist may cause dermatitis and irritation.

If there is prolonged contact with skin, wash affected area with soap and water. If oil contacts eyes, flush with water immediately. Remove saturated clothing.

If swallowed, do not try to vomit. Seek immediate medical attention.

When handling liquid oil, wear rubber gloves. If prolonged contact with mist is likely, wear approved respirator.

WARNING

Lifting Components With Hoist

Lifting or hoisting of components shall only be done by designated personnel.
The load capacity rating shall be clearly marked on hoist. Do not exceed load rating.
Inspection and testing for cracks or defects in hoist system shall be performed on a regular basis.
Before lifting, alert personnel in immediate areas.
Before lifting, balance the load.
Do not stand under load while it is being moved from one area to another on a hoist.
Do not stand under load to do maintenance work.

WARNING

Hydraulic Pressures

High pressures used in testing hydraulic components can cause line rupture or component failure.
Only qualified personnel shall operate, service, and maintain hydraulic test equipment.
Use heavy plastic shielding at least 1/2 inch thick when applying pressures over 250 psi to prevent injury to personnel.

WARNING

Hydraulic Fluid

Hydraulic fluid is toxic. It can irritate skin and eyes and cause burns. When fluid is decomposed by heating, it releases toxic gases.
Avoid inhaling. Use only with adequate ventilation. If prolonged contact with mist is likely, wear an appropriate respirator.
Avoid contact with skin, eyes, or clothing. Wear rubber gloves if handling liquid.
In case of contact with skin, immediately wash skin with soap and water. In case of contact with eyes, flush them immediately with clear water and get medical attention.
If liquid is swallowed, do not induce vomiting; get immediate medical attention.

WARNING

Compressed Air

Do not use more than 30 psi compressed air for cleaning purposes. Debris propelled under pressure can cause injury to eyes.

Use eye protection to prevent injury to personnel.

WARNING

Flare Dispenser

Flares can accidentally fire, sometimes from stray voltage. Injury or death can result.

Remove all electrical power from helicopter before installing loaded payload module on dispenser assembly.

Keep hands and face away from end of payload module during installation.

WARNING

Maintenance Platforms/Workstands

Use only authorized maintenance platforms/workstands, or other approved locally procured stands and restraint equipment, when working above 10 feet on helicopters in a nontactical environment. Otherwise, personnel injury could result from accidental falls.

WARNING

Black Light Inspection Eyewear

Do not wear eyeglasses having light sensitive lenses while performing magnetic particle (black light) or fluorescent penetrant inspections.

Such lenses have a 16 to 45 percent light transmission loss.

Wearing them can result in failure to detect flaws and cracks under ultraviolet light.

WARNING

Cadmium-Plated Tools

Use only chrome-plated or unplated steel tools when working on the helicopter.

Cadmium or zinc-plated tools are not permitted, since these platings are prone to chipping and flaking. The chips and flakes could cause corrosion or fluid contamination.

All tools, regardless of plating type, shall be serviceable and free of chipping.

LIST OF EFFECTIVE PAGES

Insert latest changed pages; dispose of superseded pages in accordance with regulations.

NOTE: On a changed page, the portion of the text affected by the latest change is indicated by a vertical line, or other change symbol, in the outer margin of the page. Changes to illustrations are indicated by miniature pointing hands. Changes to wiring diagrams are indicated by shaded areas.

Dates of issue for original and changed pages are:

Original	19 September 2002
Change 1	30 September 2003

Page No.	*Change No.		Page No.	*Change No.
			10-23 through 10-386	... 0
Title	0		10-387 and 10-388 1
a through g	0		10-389 through 10-565	.. 0
h blank	0			
A	1			
B blank	1			
i	1			
ii blank	1			
10-1 through 10-21	0			
10-22 blank	0			

*Zero in this column indicates an original page.

**AVIATION UNIT AND AVIATION
INTERMEDIATE MAINTENANCE MANUAL
CH-47D HELICOPTER**

REPORTING ERRORS AND RECOMMENDING IMPROVEMENTS

You can improve this manual. If you find any mistakes or if you know of a way to improve these procedures, please let us know. Mail your letter or DA Form 2028 (Recommended Changes to Publications and Blank Forms) located in the back of this manual, directly to: Commander, U.S. Army Aviation and Missile Command, ATTN: AMSAM-MMC-MA-NP, Redstone Arsenal, AL 35898-5000. A reply will be furnished to you. You may also provide DA Form 2028 information to AMCOM via e-mail, fax, or the World Wide Web. Our fax number is: DSN 788-6546 or Commercial 256-842-6546. Our e-mail address is: 2028@redstone.army.mil. Instructions for sending an electronic 2028 may be found at the back of this manual immediately preceding the hard copy 2028. For the World Wide Web use: <https://amcom2028.redstone.army.mil>.

DISTRIBUTION STATEMENT A: Approved for public release; distribution is unlimited.

TABLE OF CONTENTS

		PAGE NO.
VOLUME	VIII	
CHAPTER	10 FUEL SYSTEM	10-1
Section	I Fuel System Description and Theory of Operation	10-1
Section	II Fuel Tanks	10-23
Section	III Fuel Systems	10-159
INDEX	See Volume XI	

*This manual together with TM 55-1520-240-23-1, TM 55-1520-240-23-2, TM 55-1520-240-23-3, TM 55-1520-240-23-4, TM 55-1520-240-23-5, TM 55-1520-240-23-6, TM 55-1520-240-23-7, TM 55-1520-240-23-9, TM 55-1520-240-23-10, TM 55-1520-240-23-11, supersedes TM 55-1520-240-23-1, TM 55-1520-240-23-2, TM 55-1520-240-23-3, TM 55-1520-240-23-4, TM 55-1520-240-23-5, TM 55-1520-240-23-7, TM 55-1520-240-23-8, TM 55-1520-240-23-9, TM 55-1520-240-23-10, 10 May 1983, and TM 55-1520-240-23-6, 6 May 1983, including all changes.

CHAPTER 10

FUEL SYSTEM

SECTION I

FUEL SYSTEM DESCRIPTION AND THEORY OF OPERATION

DESCRIPTION

The airframe fuel system supplies fuel to the two engines, the APU, and the cabin heater. Fuel is contained in six fuel pods mounted to the outside of the helicopter between sta. 189 and 438.

The system has two subsystems, left and right. The left (No. 1) system supplies fuel to the No. 1 engine and the APU. The right (No. 2) system supplies fuel to the No. 2 engine and the heater. In case of an emergency, an engine crossfeed system allows fuel from one system to supply both engines.

Each subsystem is made up of three fuel tank assemblies (forward auxiliary, main, and aft auxiliary). The auxiliary tanks act as storage before fuel is transferred to the main tanks.

The fuel system with **82** has provisions for connecting an Extended Range Fuel System (ERFS II), as described in Chapter 16, Section XV.

FUEL TANK PODS

There are three fuel tank pod structures attached to each side of the fuselage external walls. The forward auxiliary pod extends from sta. 189 to 238, the main pod from sta. 262 to 372, and the aft auxiliary pod from sta. 396 to 438. Each pod structure is hinged at its lower edge and attached to the fuselage structure by bolts and fasteners to provide rigid support for an internal fuel tank cell. Pod skin is made up of laminated honeycomb and fiberglass panels riveted to magnesium alloy bulkheads and stringers. The end bulkheads of each pod structure form the forward and aft facing walls of the intertank and end bays.

FUEL TANK CELLS

Inside each pod is a fuel tank cell. Each cell is constructed of rubber/fabric laminates, with adapters and fittings bonded into the construction of the cell to provide for the mounting of internal components, access doors, and mounting clamps. Each cell is self-sealing against 50 caliber projectiles and is crash-resistant. The tank cells are secured in the pods by bolts that are

threaded into the tank supports from the exterior of the pod structure and by fuel tank components at their tank attachment points.

Fuel cells are constructed of self-sealing crashworthy material. Breakaway, self-sealing fittings are installed in each fuel line interconnecting fuel tanks to the fuselage structure. Under impact, the fittings shear or break at a designated location and seal themselves to retain fuel, thus keeping fuel spillage and postcrash fire hazard to a minimum.

Fiberglass backing boards are taped to the fuselage behind the fuel pods to protect the self-sealing feature of the cells.

FUEL TANK COMPONENTS

Each operational fuel tank contains plumbing and wiring as well as the following components:

Shutoff Valve —

All tanks have a shutoff valve mounted on the access door at the point of fuel entry. The valve closes when back pressure sensed by the high level control valve indicates that the tank is full.

High Level Control Valves —

Each fuel cell contains a high level control assembly consisting of two controllable valves (primary and secondary). When they sense that the tank is filled, they cause the closing of the shutoff valve at the tank access door.

Low Level Thermistor —

Each auxiliary tank has two thermistors mounted on the fuel boost pump. They shut off the pump when the tank is empty.

Fuel Boost Pump —

Each auxiliary tank has a fuel pump to transfer fuel to the main tank. Each main tank has two pumps which supply fuel to the fuel feed lines. The pumps are fitted on brackets on the floor of the tank cell, above the drain valves. They are connected by flexible hoses to the tank internal piping.

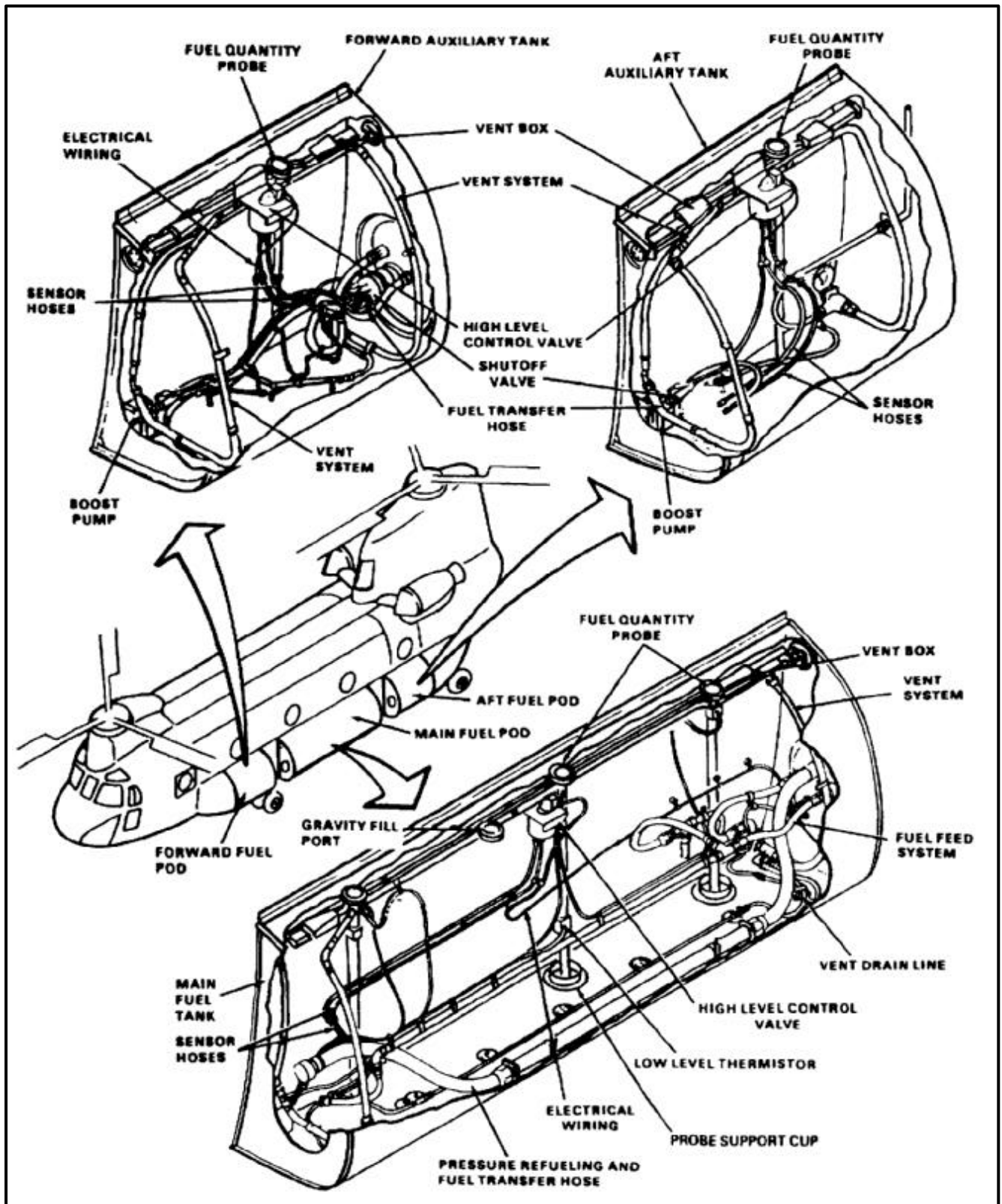

Drain Valves —

There are two drain valves in each tank, one aft and one forward. The forward valve is a sump drain. The aft valve is a sump drain and is open to the vent system.

Vent System —

The vent system in each tank is made up of tubes and two vent boxes. The system allows outside air to enter and exit the fuel cell during refueling and fuel usage. The system also prevents fuel from spilling in the event of a rollover.

Fuel Quantity Probes —

Each fuel subsystem has a fuel quantity indicating system. Five tank quantity transmitter probes (one in each auxiliary tank and three in the main tank) provide input to the indicating system. The fuel quantity signal is directed through a seven position switch to a fuel quantity indicator on the center instrument panel. The selector enables the operator to read fuel quantity in each of the six tanks individually, or to read the total fuel quantity. Probe support cups, located on the bottom of the cell, prevent excessive movement of the fuel probes.

MAIN TANK COMPONENTS

The following components are used only in the main tanks:

Jet Pump —

A jet pump in each main tank evacuates fuel from the across helicopter pressure refueling lines into the main tank.

Vacuum Relief Check Valve —

On aircraft with a vacuum relief check valve is located in the pressure refueling bay, connected through a line to the pressure refueling receptacle. The valve is vented to atmosphere which prevents a vacuum from forming in the refueling lines during jet pump operation.

Engine Feed Suction System —

This subsystem has a bellmouth and check valve into the engine fuel feed system. If both boost pumps in a main tank fail, the engine fuel boost pump can still draw fuel from that tank through the bellmouth. Helicopter altitude must not exceed **6,000 feet** for this system to be operational.

Delta Pressure Check Valve —

A delta pressure check valve is attached to each fuel boost pump in the main tank. These check valves prevent reverse flow and suction of air if a boost pump is uncovered.

Fuel Low Level Warning System —

This system has two thermistor units (one on the center probe in each main tank), a dual control unit on the cockpit floor below the center console, and two lights on the master caution panel. The thermistors transmit a signal to the dual control unit and activate the warning lights on the caution panel when the fuel level drops below approximately **65 gallons**.

INTERTANK AREA

There are two intertank areas, forward and aft, between the three fuel pods in each subsystem. The forward intertank areas are in the front landing gear bays. They are functionally similar except that the right intertank area has a pressure refueling adapter and a control panel.

The right and left forward intertank areas each contain two check valves, five breakaway fittings, one pressure switch, a fuel vent tube from the forward fuel tank, and an evacuation line connected to the jet pump in each main tank.

The aft intertank areas are between the main fuel pod and the aft auxiliary pod. The right aft intertank area has connections to the fuselage for the heater fuel feed, a solenoid valve, No. 2 engine fuel feed and ferry fuel. The left aft intertank area has fuselage connections for APU fuel feed, No. 1 engine fuel feed, and ferry fuel. The APU fuel boost pump, solenoid valve, and APU pump drain are also located in the left aft intertank area.

Both aft intertank areas have six breakaway fittings, two check valves, two motor operated valves, one pressure switch, main tank vent tube, and plumbing.

The aft tank fuel vent tube is in the area behind the aft auxiliary tank on each side.

FUEL QUANTITY INDICATING SYSTEM

A fuel quantity selector switch and an indicator are on the center instrument panel and on the singlepoint pressure refueling panel in the right forward intertank bay area. They receive input signals from the fuel quantity probes in the fuel tanks through a switch box located in the cabin at sta. 232. The selection of which panel is in use is made at the overhead single-point fuel control panel.

Selector Switch —

The selector switch is a seven-position rotary switch that allows the operator to choose whether the indicator will read the amount of fuel remaining in any one of the six tanks or the total fuel remaining.

Indicator —

Each indicator shows the amount of fuel, in pounds, remaining in the selected tank. Individual tank quantities are shown by a pointer. The total is shown on a digital readout.

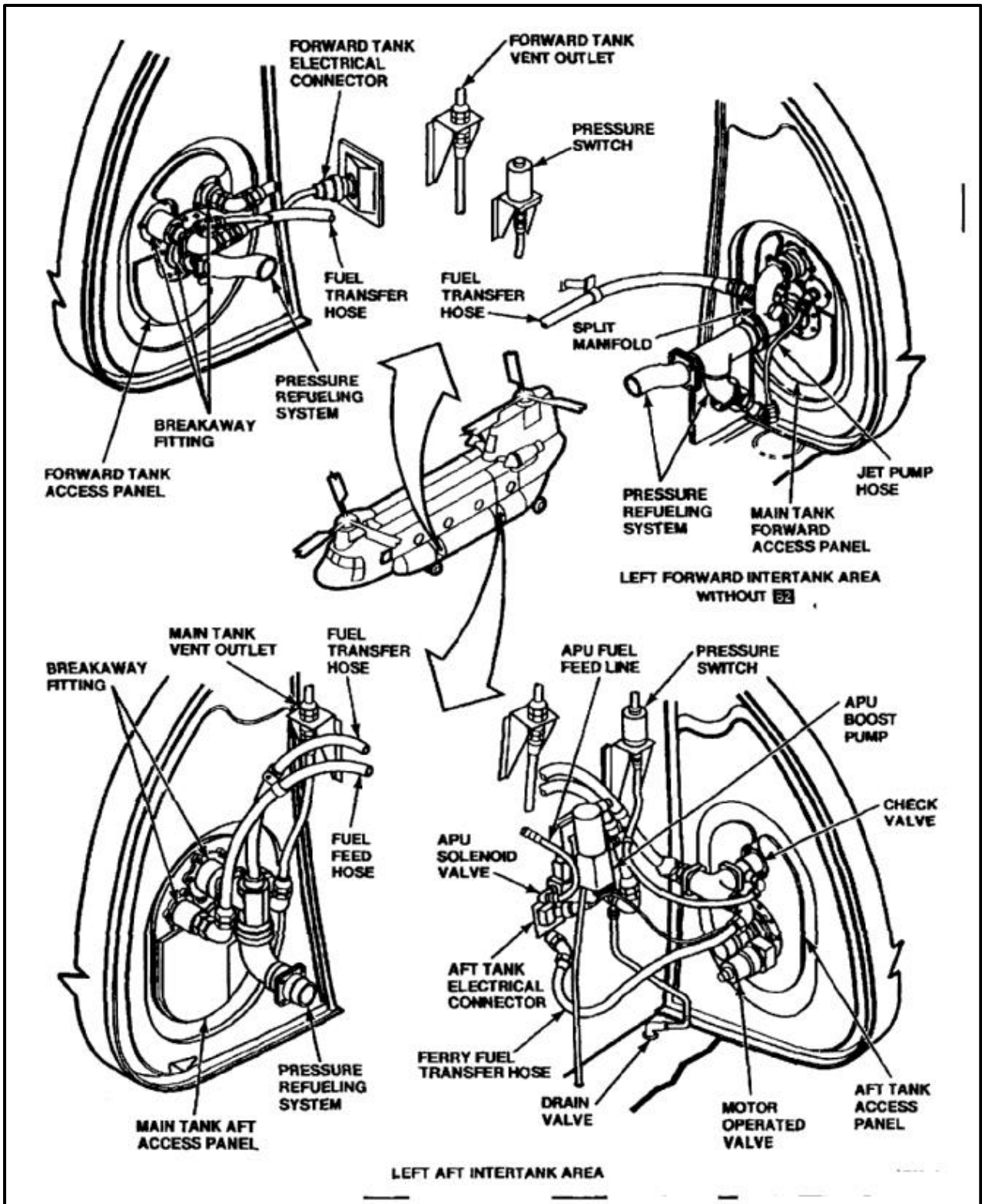

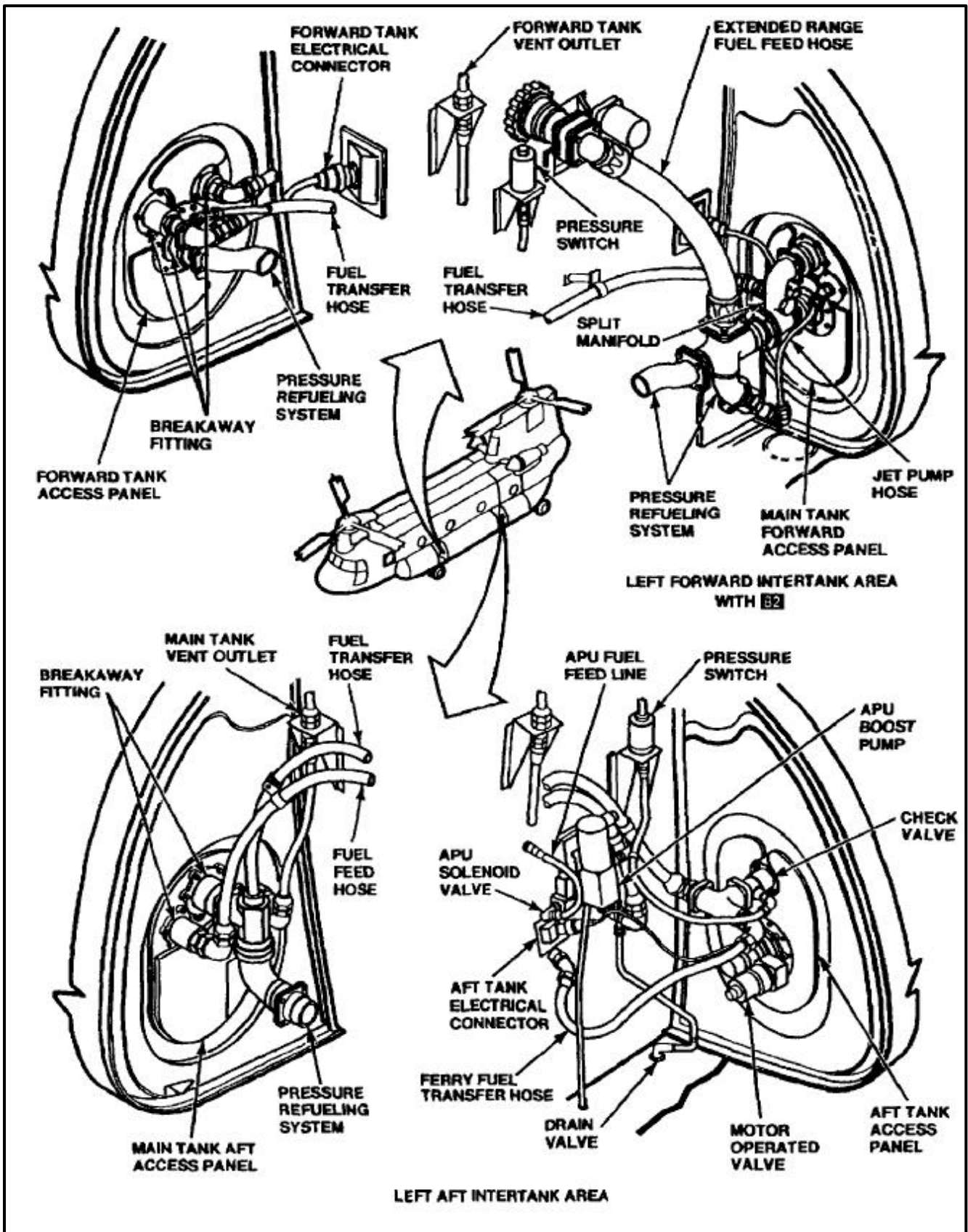

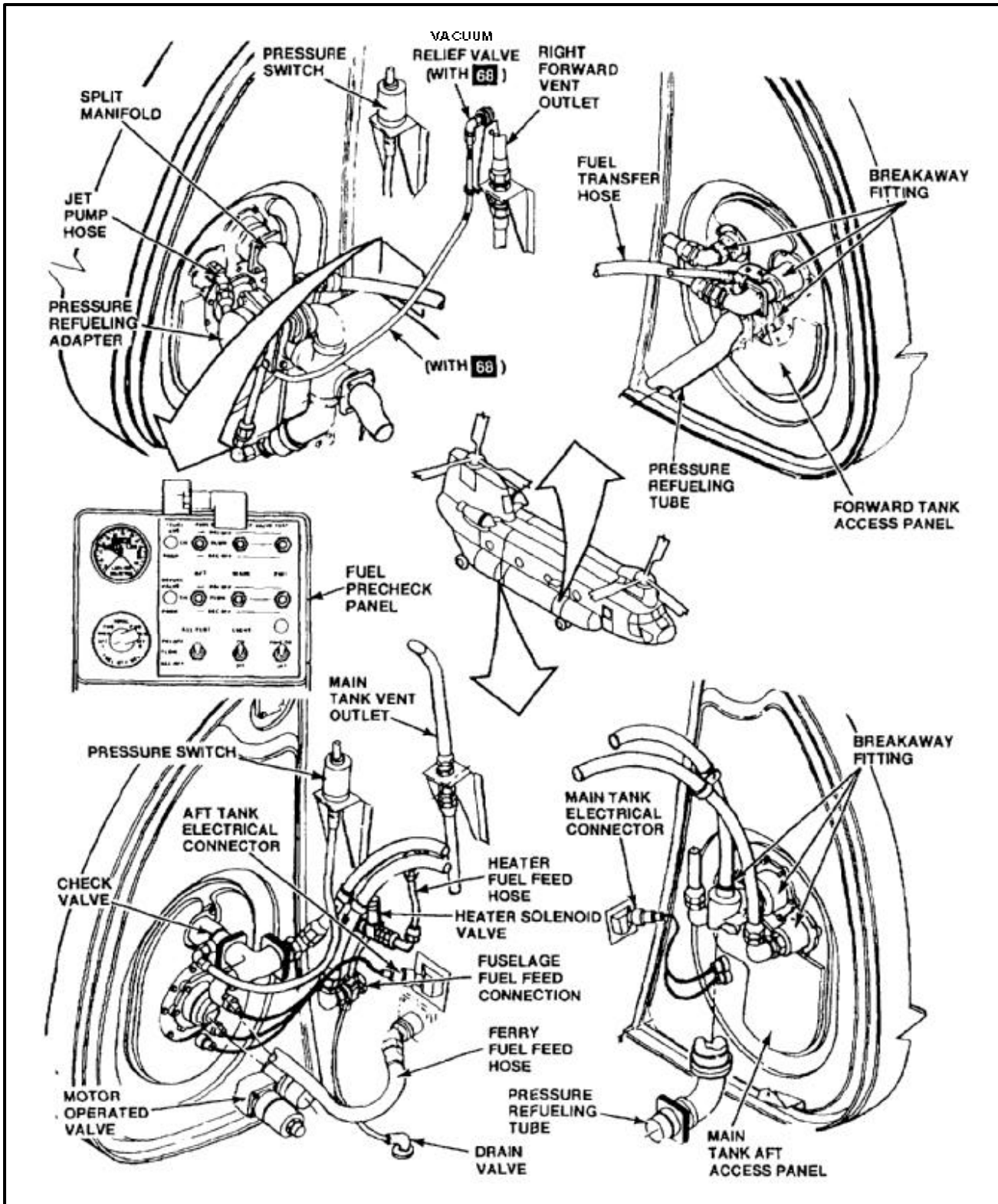

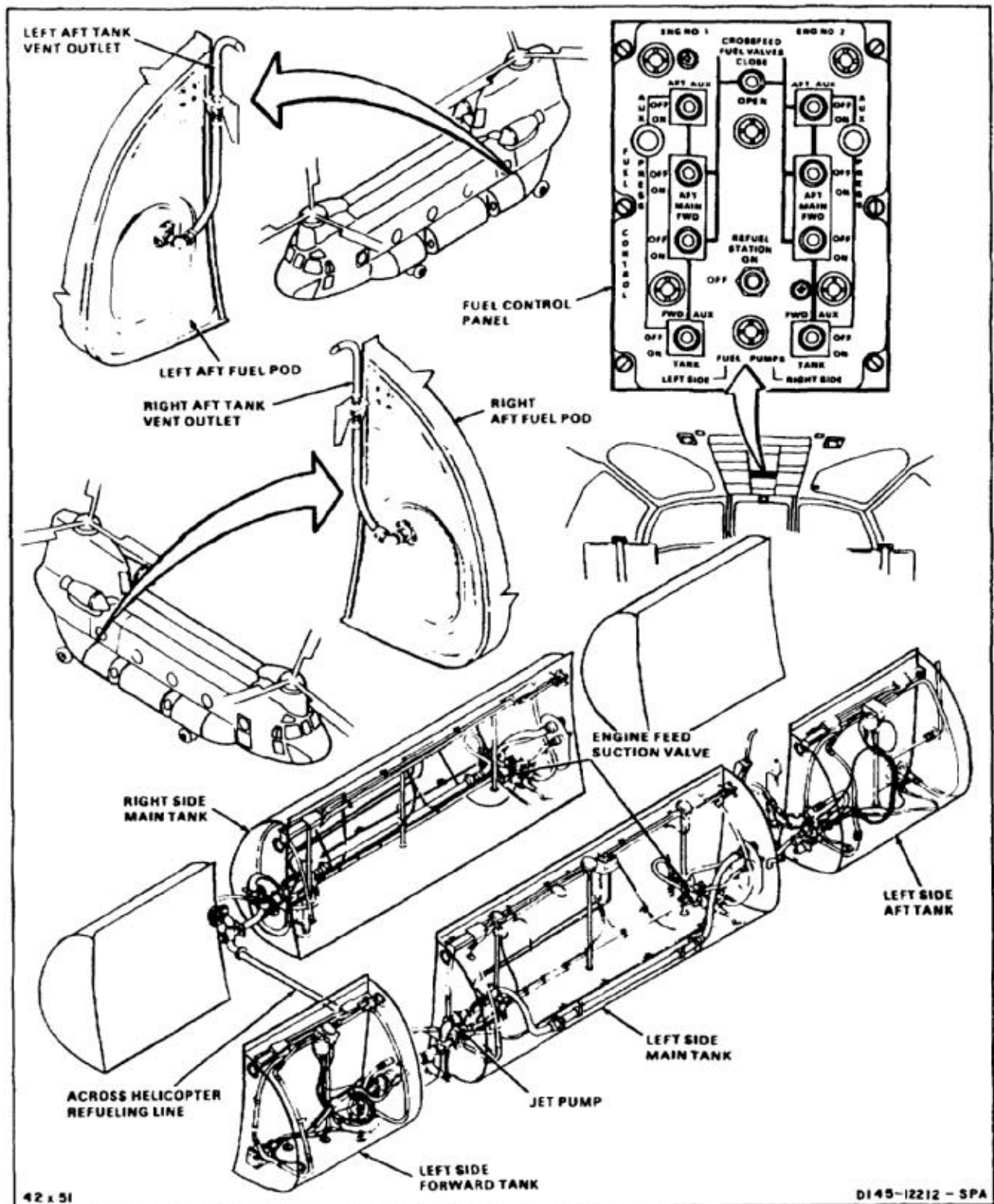

FUEL TRANSFER

Fuel is pumped from the main tank into the fuel feed line by two boost pumps. Fuel is transferred from each auxiliary tank to the main tank through an internal boost pump. Thermistors on the pump shut it off when fuel is depleted.

Fuel transfers from the aft auxiliary tank through the same tube in the main tank that is used to refuel the aft tank during pressure refueling. Fuel passes through the top orifice in this split manifold and enters the main tank through the bottom orifice in this split manifold.

In addition to the engine fuel feed and APU fuel feed systems there is a heater fuel feed system.

The heater fuel feed line leads from the cross connector in the right aft intertank bay. The fuel passes a solenoid-operated valve, enters the fuselage, and leads forward to the heater.

APU FUEL FEED SYSTEM

The APU fuel feed system begins in the left aft intertank area. Fuel from the main tank enters the cross connector and passes into the APU line on top of the connector. The fuel line passes through a boost pump and solenoid valve before entering the fuselage. Inside the fuselage, the fuel line passes through a manual shutoff valve at sta. 540. It passes a quick-disconnect fitting at sta. 600 and enters the APU.

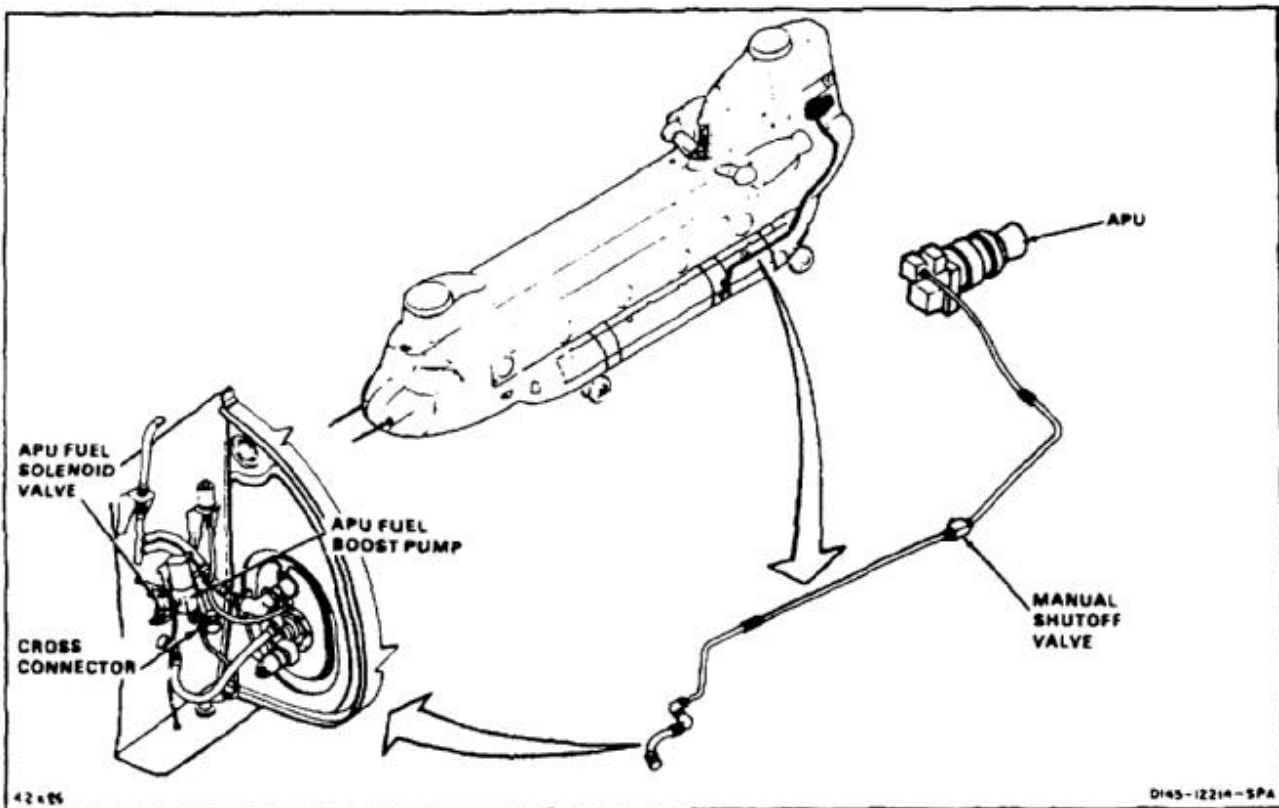

REFUELING

There are two methods of refueling the helicopter.

Gravity Fill Refueling —

Each tank has a gravity fill port which is opened for individual tank refueling. About **30 minutes** are necessary to refuel the helicopter by this method.

Single Point Pressure Refueling —

The pressure refueling system allows the aircraft to be completely refueled in about **4 minutes** with fuel supplied at **300 gallons per minute at 55 psi**. Refueling is controlled by a panel located in the right front intertank area. Fuel enters the pressure refueling adapter and goes to the forward auxiliary tanks through a breakaway fitting on the aft access door. Fuel enters the main tanks through the bottom orifice of a split manifold. The top orifice of the manifold is connected to a tube which runs through the main tank and supplies the aft auxiliary tank. Two sensing tubes between the high level control valve and shutoff valve cause the shutoff valves to close when each tank is filled. The jet pump draws fuel from the forward pressure refueling lines when the main tank boost pumps are turned on. On aircraft with **68** a vacuum relief check valve opens when fuel is drawn from the pressure refueling lines. Air is drawn into the pressure refueling lines as the jet pump removes the remaining fuel, and prevents a vacuum from forming in the lines. On aircraft with **82** installed, the internal tanks can also be refueled using this method.

The capacity of the airframe fuel system is **1034 gallons** when all tanks are filled.

The capacities of individual tanks are shown below:

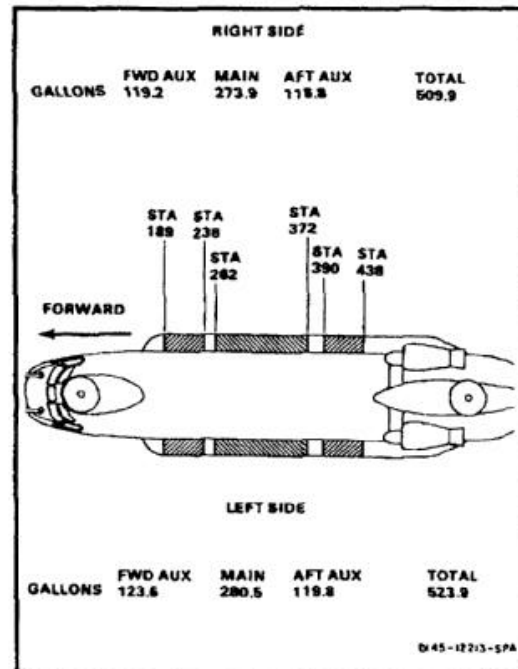

ENGINE FUEL FEED SYSTEM

Engine fuel is supplied by the airframe fuel system. The No. 1 (left) engine is supplied by the No. 1 (left) fuel subsystem. The No. 2 (right) engine is supplied by the No. 2 (right) fuel subsystem.

The fuel passes through a breakaway fitting in the rear wall of the main tank into the aft intertank area to a cross connector on the fuselage.

The cross connector directs fuel through the fuselage and to a drain fitting on the bottom skin of the intertank bay. The connector on the left side also directs fuel to the APU and on the right side to the heater.

Interconnecting the two engine fuel feed systems is a fuel crossfeed line with two motor operated shutoff valves. The crossfeed system allows fuel from one

system to supply both engines in case one system becomes inoperative. The No. 2 system has a manually operated valve for defueling purposes.

The engine fuel passes a pressure switch, motor operated valve, and fuel flow transducer before passing through a fuselage quick-disconnect fitting on the way to the engine fuel boost pump.

An engine feed suction line in each main tank works as a backup system in case both main tank boost pumps fail. When one main tank boost pump fails, the check valve for that pump closes to prevent reverse flow, or air being drawn into the engine feed line. When both boost pumps fail, fuel is drawn by the engine fuel boost pump through a separate hose in the main tank. Flight altitude must not exceed **6000 feet** in this condition.

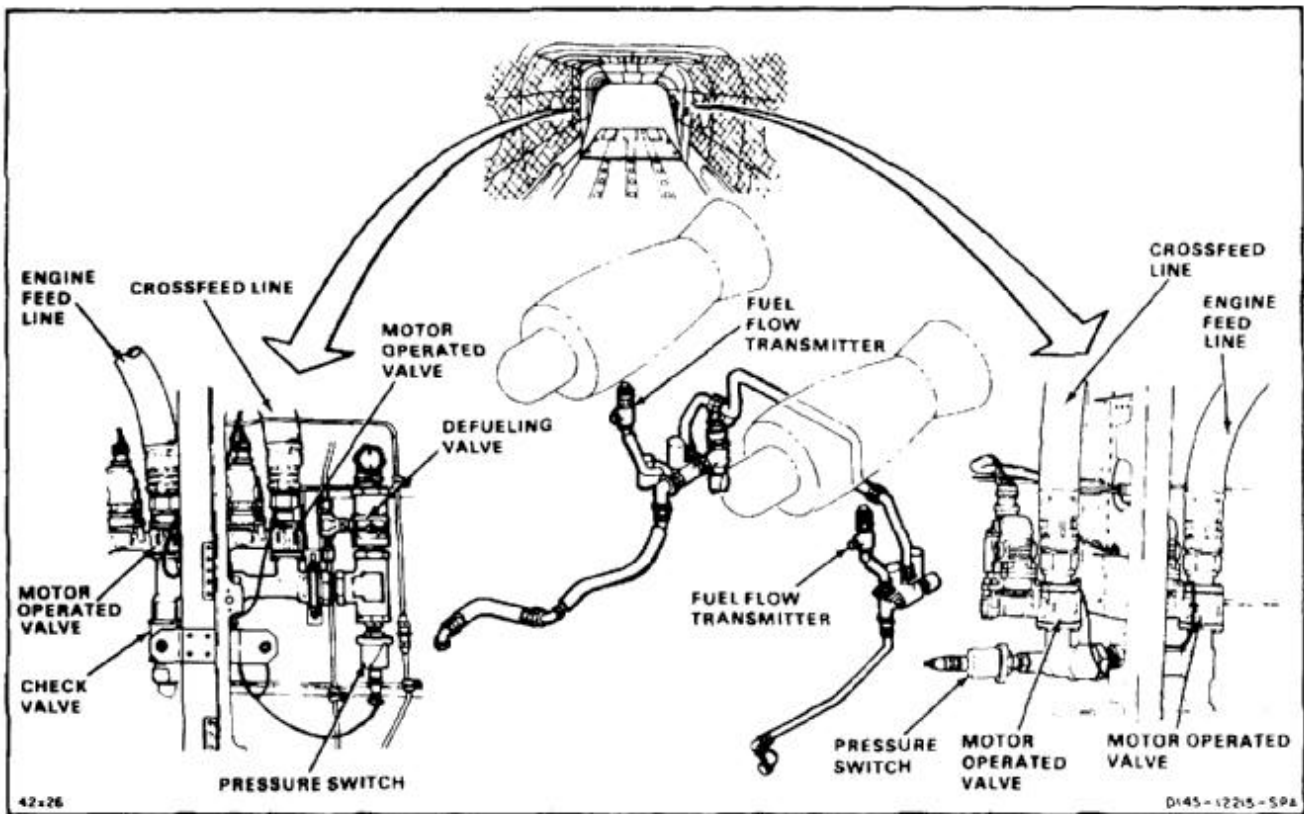

FERRY FUEL SYSTEM WITH 19

Provisions exist in the helicopter for use of a ferry fuel system. The provisions consist of two ferry fuel fittings in the left and right side of the cabin at approximately sta.

375. They are connected to the main fuel tank system. In addition, 3 vent fittings are at the top of the cabin at sta. 240, 360 and 460.

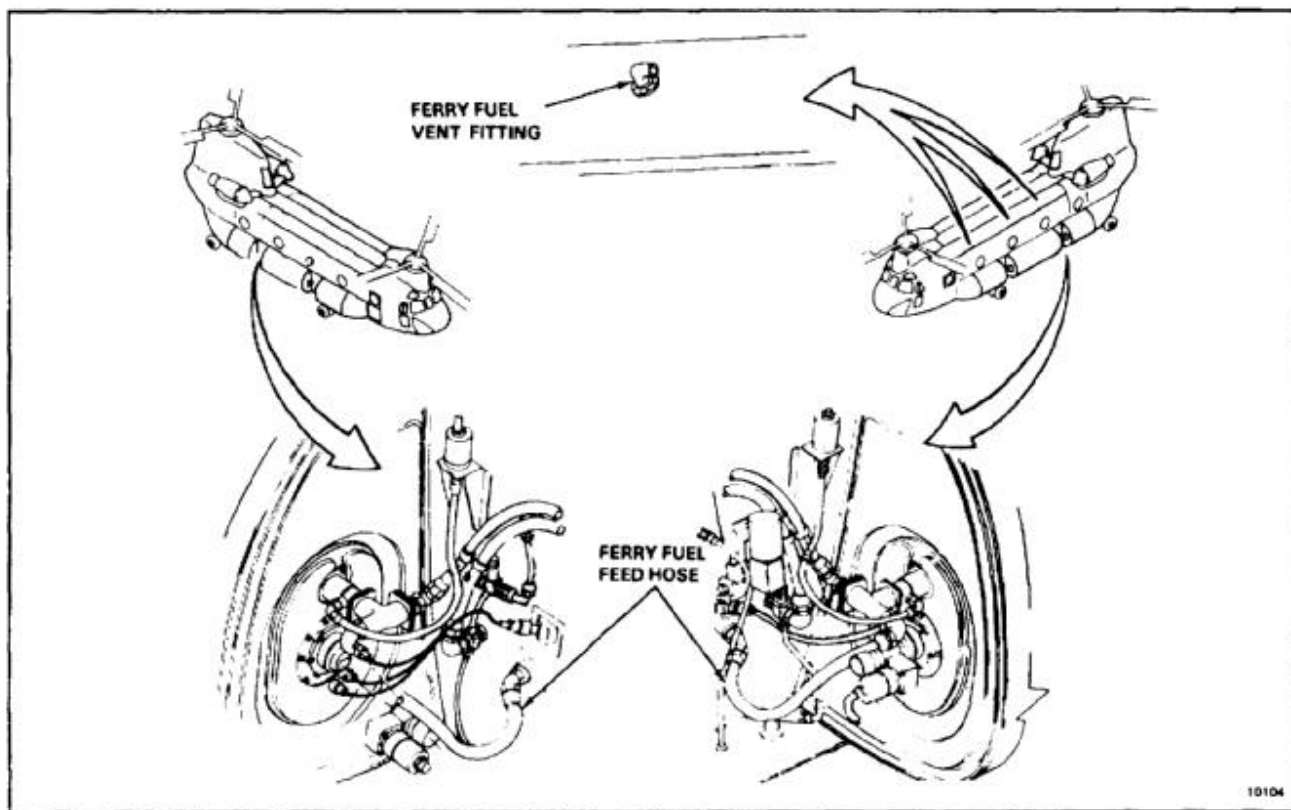

10104

THEORY OF OPERATION FUEL DELIVERY SYSTEM

The fuel pumps for all tanks operate on **115 vac** from number 1 or 2 ac bus and are controlled by **28 vdc**. When the ac circuit for any pump is closed, **115 vac** is connected to a relay in the fuel pump control relay box. Closing the pump dc circuit breaker connects dc voltage to the pump control switch on the overhead fuel control panel.

On the main tank fuel pumps, placing the overhead panel switch to ON operates the relay directly, connecting ac power to the pump to operate it.

On each auxiliary tank fuel pump, placing the panel switch to ON connects **28 volts** to a thermistor control unit in the cabin.

Two thermistors are mounted on each auxiliary fuel pump. As long as both thermistors are covered by fuel, **28 volts** passes through the control relay connecting ac power to operate the pump. When the fuel level drops enough to uncover both thermistors, their resistance changes, opening the control relay and shutting the pump off. Two thermistors are used to ensure that the pump does not shut down in response to fuel sloshing.

During normal operation with all fuel pumps operating, each of the two main pumps in the left and right systems delivers fuel through its check valve to a common engine fuel line. Fuel passes through the feed line through a system check valve, a pressure switch, a main engine fuel valve and a fuel flow transmitter to the engine fuel system.

The check valve has a thermal relief feature that allows fuel to flow back into the tank before the temperature within the line from check valve to engine reaches a point where the line could rupture because of fuel expansion.

The pressure switch lights a capsule on the master caution panel when fuel pressure drops below **10 psi**.

The main engine fuel valve is motor-operated by **28 vdc**. It is controlled through the cockpit fire warning handle for that engine. A lever on the valve allows it to be also shut off manually.

The flow transmitter provides a signal to a gage on the center instrument panel.

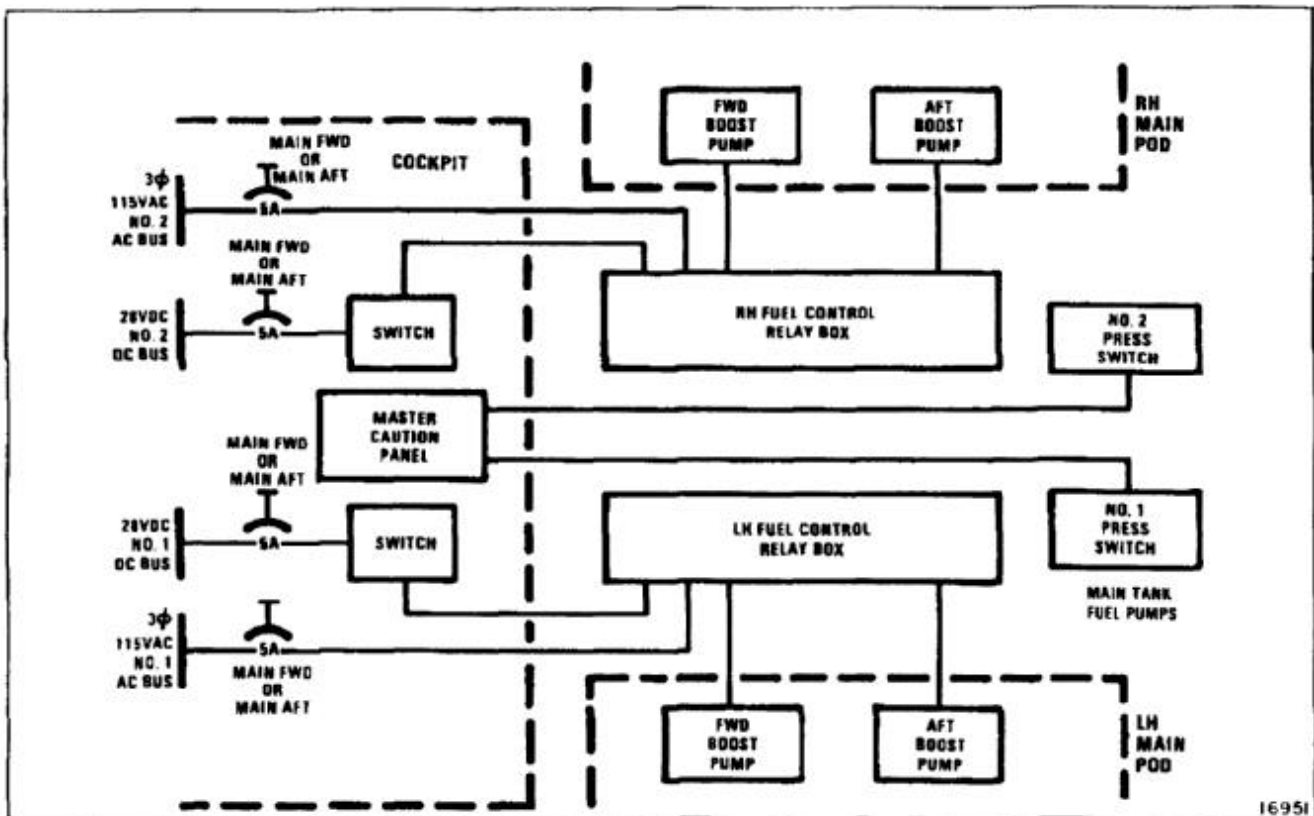

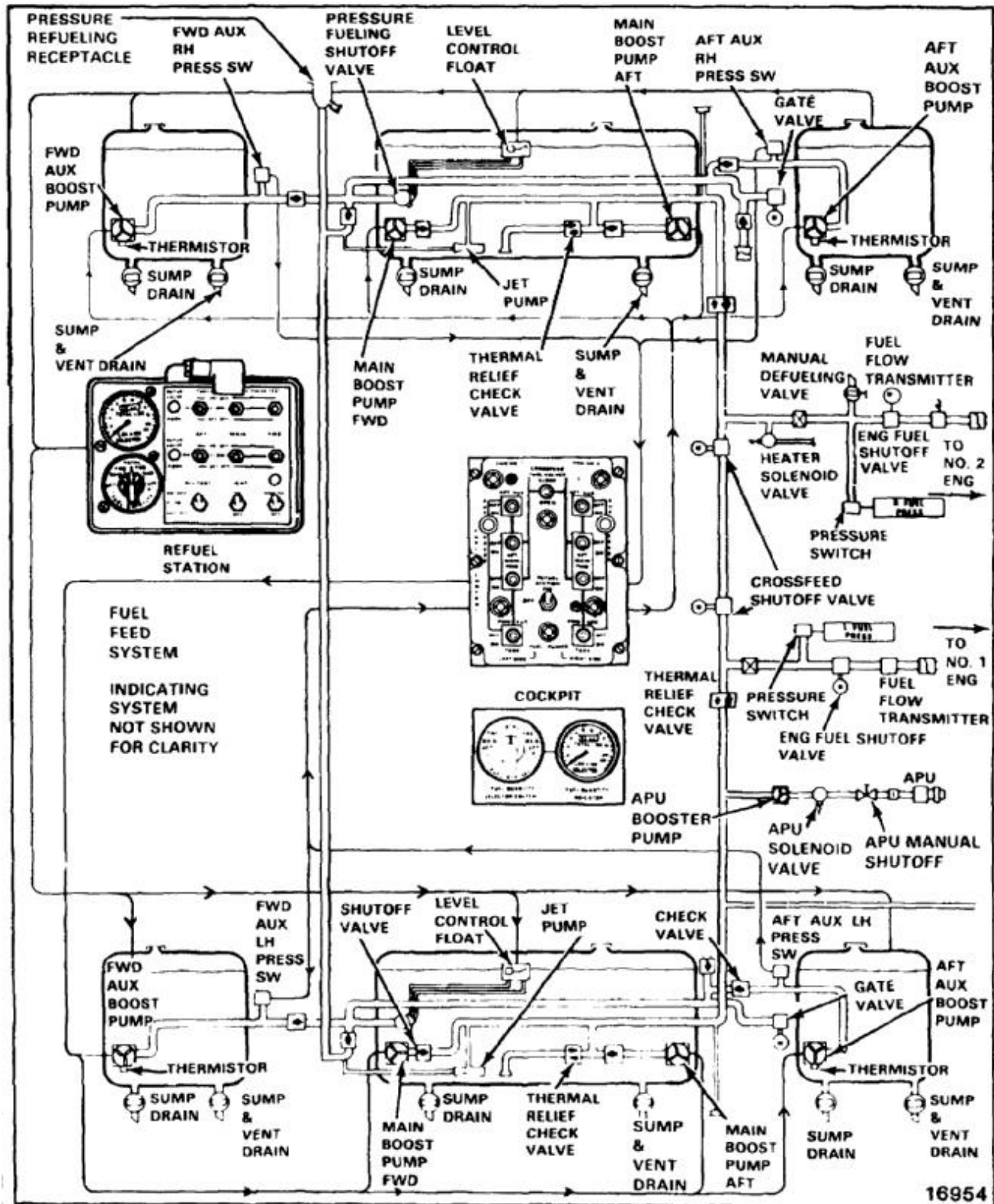

If either fuel supply system becomes inoperative, both engines can be supplied by the other system by opening the engine crossfeed valves. The valves operate on **28 vdc** from the No. 1 dc bus and are controlled from the overhead fuel control panel.

Pressure from each forward main fuel pump is also used to operate a respective jet pump. Pressure to each jet pump is provided by a line tapped into the feed line between its main fuel pump, and feed line check valve. A suction line from each jet pump is connected to the pressure refueling lines, such that when either of the forward main pumps are operated, pressure through its jet pump causes fuel to be drawn from the pressure refueling lines. On aircraft with **68**, a vacuum

relief check valve is installed to prevent a vacuum from forming in the pressure refueling lines. The valve is drawn open as fuel is pulled from the lines, allowing air to displace the fuel.

Each of the engine fuel gate valves and the two crossfeed valves has indicating lights next to it that come on during the time the valve is opening or closing. The lights will also come on and remain on if the valve stops at any position other than fully open or closed.

Power to operate the indicator lights comes from the **28 vdc** buses.

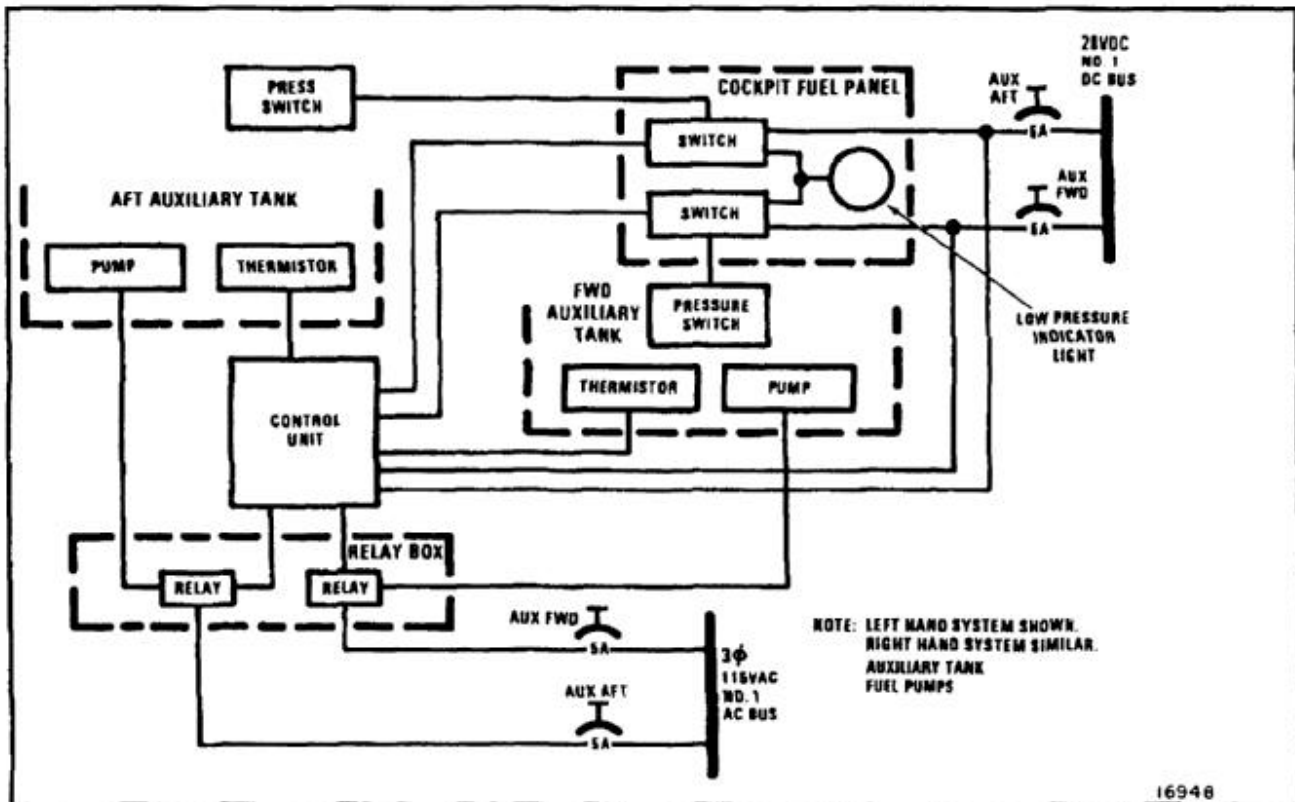

FUEL QUANTITY INDICATING SYSTEM

The basic sensing elements of the indicating system are the fuel quantity probes in each tank. Each probe is a capacitor in an indicator bridge circuit. Since the dielectric constant of fuel is twice that of air, the capacitance of a probe is twice as great when the tank is full as it is when the tank is empty. At intermediate levels, the capacitance is proportional to fuel level.

Information from all probes is directed through a switch box to one of the two selector switches. From the switch, information from the selected tank or the total of all tanks is directed to the accompanying fuel quantity indicator. Each indicator contains two servo amplifiers, two servo motors, elements of bridge circuits, and calibration potentiometers.

The change in probe capacitance as the fuel level varies creates an imbalance in the bridge circuits resulting in a gage correction output signal. This signal is amplified to drive a servo motor. The motor works through

reduction gearing to move a variable resistor wiper arm to re-establish bridge balance. A pointer on the wiper shaft moves across the calibrated scale of the indicator to indicate the amount of fuel remaining in the selected tank.

The wiper arm is also mechanically linked to a counter mechanism that always displays the total fuel quantity in pounds, regardless of selector knob position.

The choice of cockpit or refueling station panel indicator is made at the overhead fuel control panel through relays in the switch box. If the REFUEL STATION switch on the overhead panel and the PWR switch at the refueling station are OFF, probe signals are connected to the cockpit selector switch. When the switches are ON, **28 vdc** is connected to the switch box to operate the relays. This connects the probe signals to the refueling station switch. At the same time, dc power is supplied to an inverter that provides **115 volt 400 Hz** single phase ac power to the refueling station indicator.

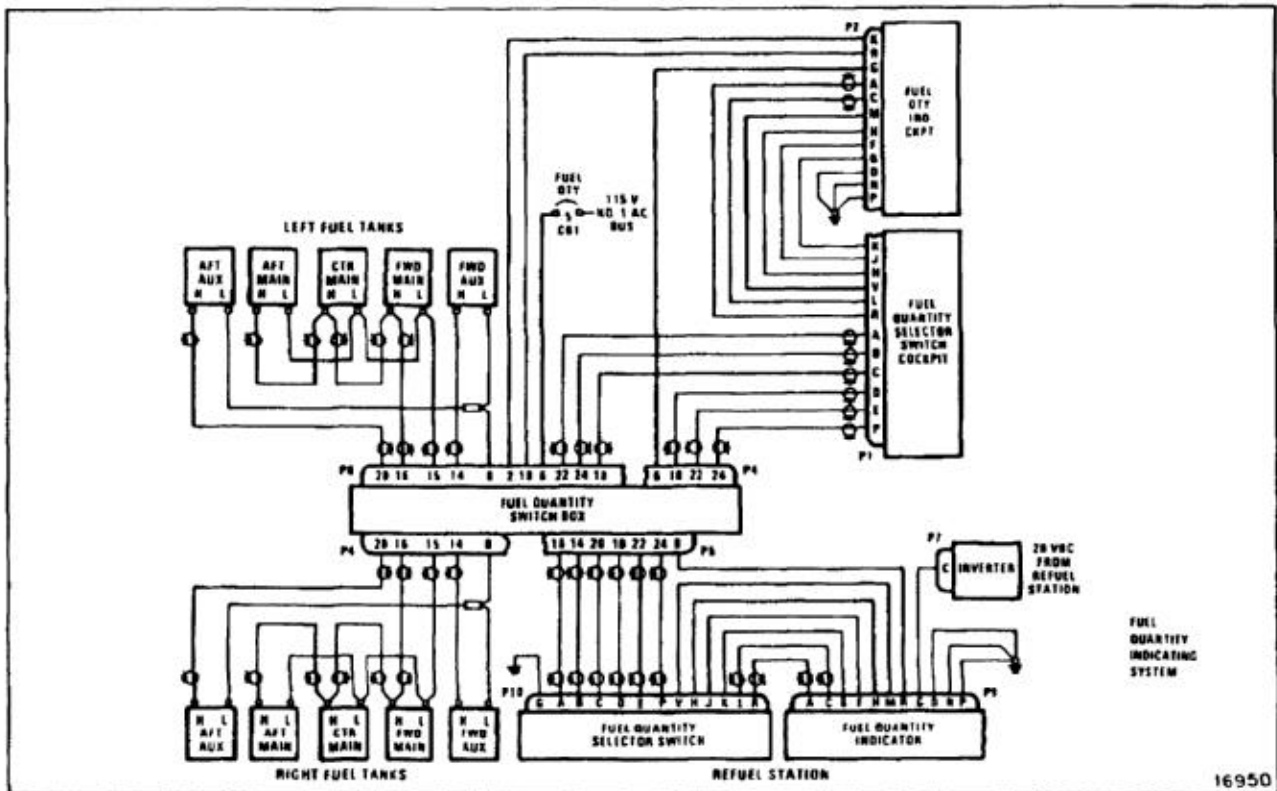

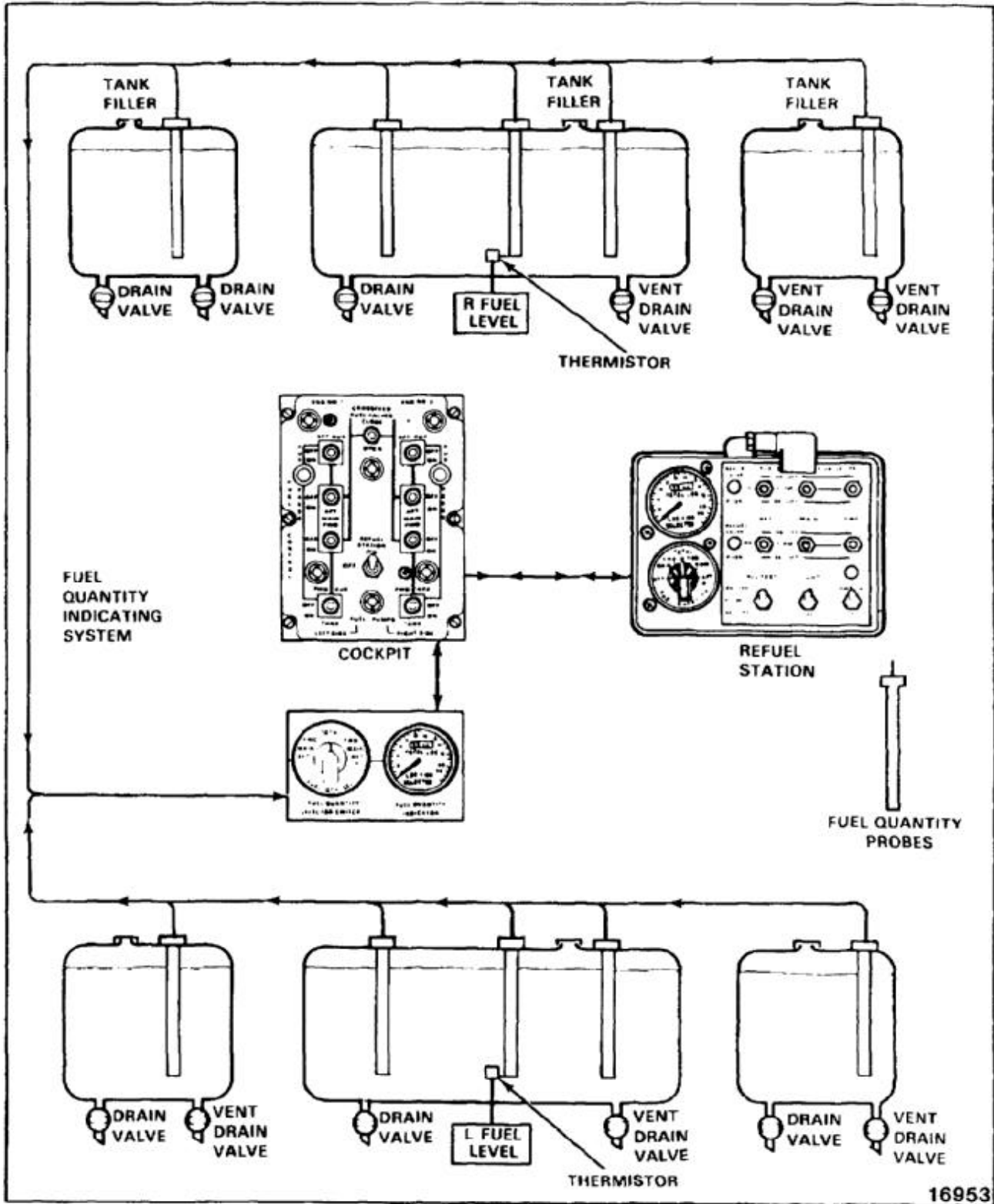

Low fuel level warning lights (L FUEL LOW and R FUEL LOW) for the left and right main tanks are on the master caution panel. They are activated by **28 volts** from the No. 1 dc bus through a thermistor on the center probe of each main tank. When the fuel level in a tank drops

to about **370 pounds**, the thermistor is uncovered. This energizes a relay within dual control unit (057A3) to close and the caution light for that tank comes on.

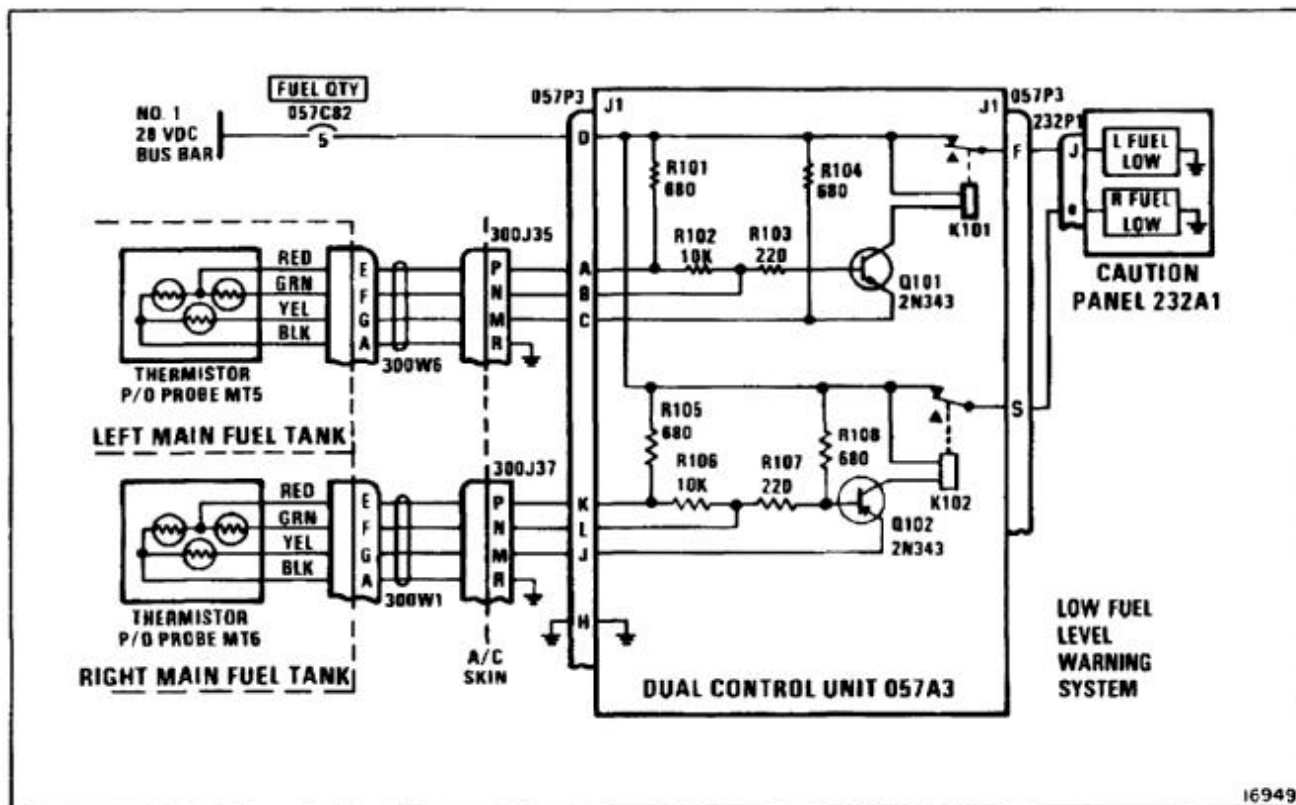

16949

PRESSURE REFUELING

When the REFUEL STATION switch on the overhead panel is turned on, the refuel control panel in the right forward intertank bay receives **28 vdc** from the switched battery bus. Turning on the PWR switch at the refuel panel causes the following to occur:

At the refuel panel, the PWR light comes on and the LIGHT switch is armed.

Twenty-eight volts is supplied to the inverter, which then supplies **115 vac** to the fuel quantity circuits.

Voltage is supplied to the fuel quantity switch box to connect signals to the refuel panel selector switch.

All high level shutoff valve test switches are armed.

The gate valve in each of the aft auxiliary fuel tanks opens.

On aircraft with **82** installed, voltage is supplied to the ERFS II control panel located on one of the internal tanks.

As fuel is added through the receptacle at the refuel station, the pressure refueling valve in each of the selected tanks is opened by fuel pressure. Fuel passes through a port in the valve into the tank.

As the fuel level within each tank rises, it lifts the floats of a shutoff valve in the tank. When the tank is full, increased pressure in the sensing lines between the shutoff valve and the refueling valve closes the refueling valve, shutting off fuel flow to that tank.

During refueling, the shutoff valves in any of the six tanks can be checked for proper operation by energizing one of the two (primary or secondary) solenoids on each valve by a switch on the refuel panel. Energizing the solenoid raises the float and closes the sensing line to the refuel valve. This shuts off fuel flow.

If desired, all shutoff valves can be checked at once by operating the ALL TEST switch on the refuel panel. This total system check is part of the normal refueling procedure.

On aircraft with **82** installed, the ERFS II REFUEL VALVE switch will need to be set to OPEN for fuel to fill the internal tanks.

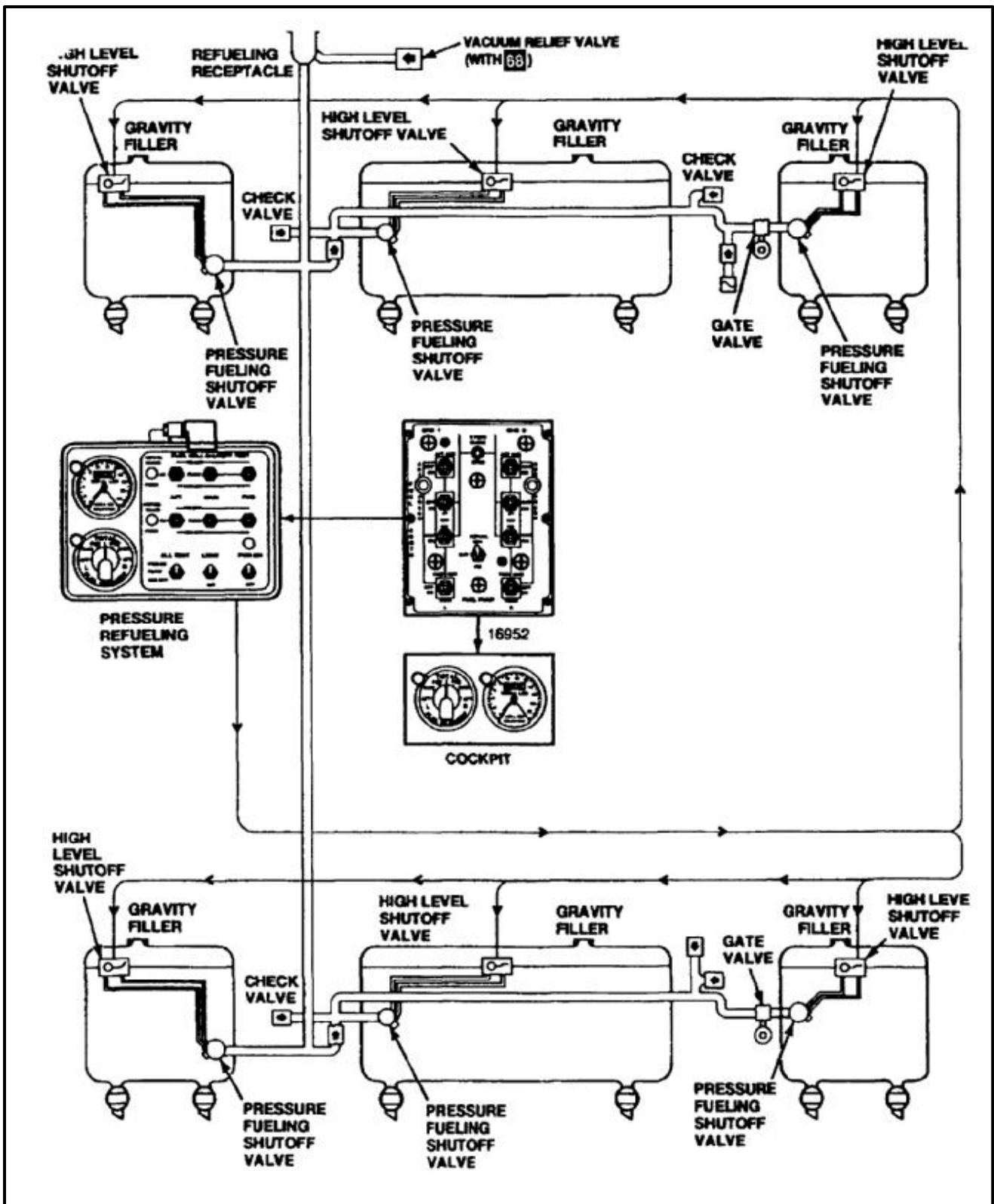

END OF TASK

SECTION II FUEL TANKS

INITIAL SETUP

Applicable Configurations:

All

Tools:

Combustible Gas Indicator
CO₂, Technical 50 Lb. Cylinder
Rubber Gloves
Respirator
Faceshield
Protective Clothing

Materials:

None

Personnel Required:

Medium Helicopter Repairer

References:

Task 10-3

Equipment Condition:

Battery Disconnected (Task 1-39)
Electrical Power Off
Helicopter Grounded (Task 1-29)
Fuel Tank Defueled (Task 10-34 or 10-35)

General Safety Instructions:**WARNING**

All regulations and instructions
for handling fuels shall be strictly
observed.

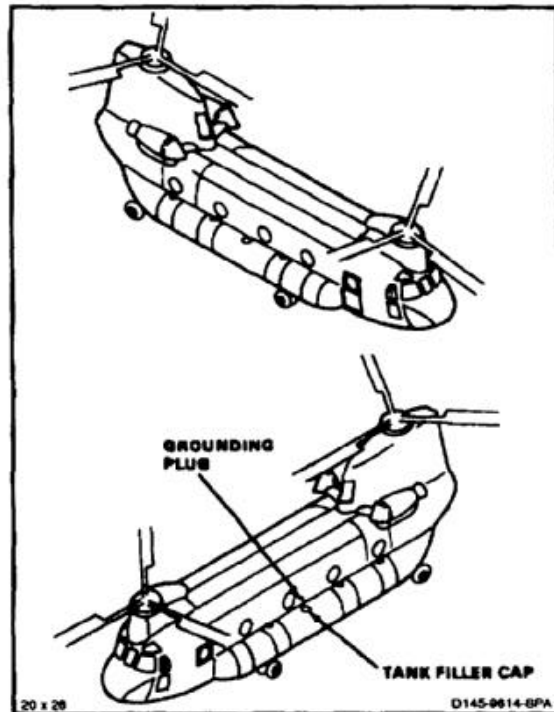

WARNING

When using a fire extinguisher as a source of CO₂ for purging fuel tanks, remove fiber horn. Ground nozzle as well as bottle itself to aircraft. Discharge CO₂ slowly to avoid generating static electricity and allowing rapid CO₂ expansion which could damage the cell.

NOTE

The size of CO₂ bottle used can vary to meet existing conditions, with **15 pound** size handy to use. Total amounts recommended are based on quantities usually needed, but more may be needed to obtain a safe reading on combustible gas indicator.

Nitrogen or other inert gas may be used instead of CO₂. Carefully observe above precautions.

Procedure is same to purge any fuel tank. No. 1 (left) main fuel tank purging is shown here.

1. Make sure that tank vent (1) is clear of obstructions and plugs, and that tank drain valves (2) are installed and closed.

WARNING

While purging, each person shall wear protective clothing, a respirator, a full facepiece and rubber gloves. Perform the purging operation in an area isolated from personnel not concerned with purging.

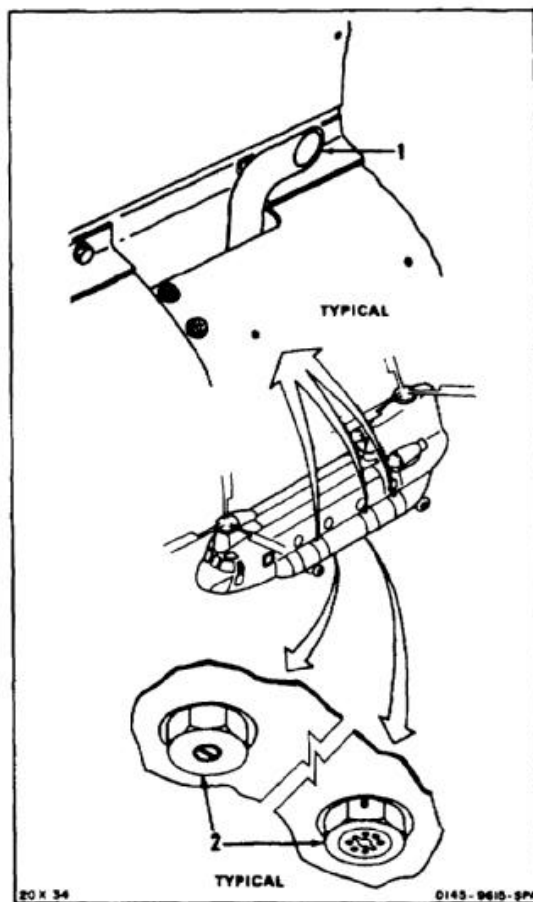

2. Remove horn from nozzle (3) of CO₂ bottle (4).
3. Remove fuel tank filler cap (5).
4. Install grounding receptacle (6) from nozzle (3) and bottle (4) into helicopter plug (7).
5. Insert nozzle (3) into open filler hole (8) in fuel tank (9). Discharge bottle at a flow rate of **1 pound-per-minute**.

NOTE

Use two **15 pound** CO₂ bottles to purge a main fuel tank. Use one **15 pound** bottle for a forward or aft tank.

6. Test purged tank (9). Use a combustible gas indicator or equivalent tester. If level of fumes is not safe, purge until level is safe.
7. Remove grounding receptacle (6) from helicopter plug (7). Remove bottle (4).
8. If personnel will work within the tank, purge with air (Task 10-3).
9. Install tank filler cap (5).

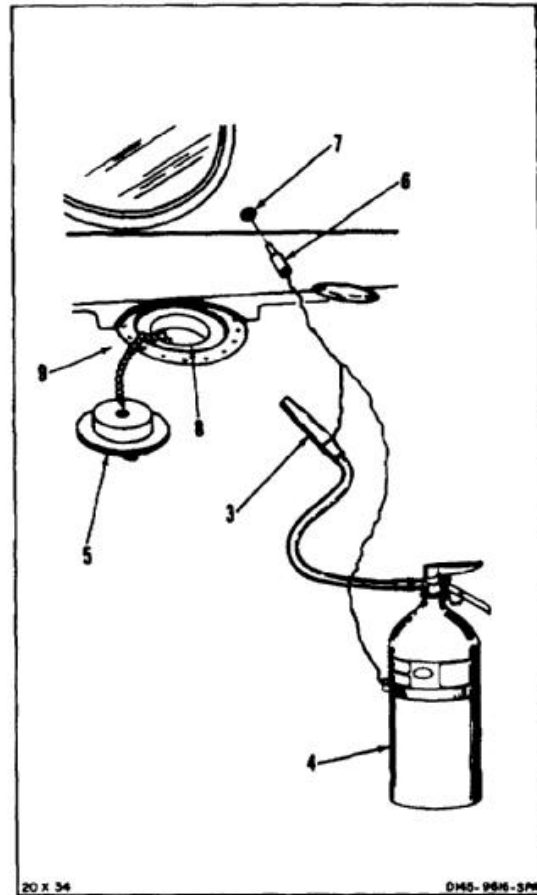
**FOLLOW-ON MAINTENANCE:**

None

END OF TASK

INITIAL SETUP

Applicable Configurations:

All

Tools:

Aircraft Mechanic's Tool Kit, NSN 5180-00-323-4692
 Air Supply, 80 to 120 Lbs. Per Sq. In.
 Lamb Air Remover (T-200)
 Combustible Gas Indicator (T-219)
 Grounded Air Blower (or Equivalent)

Materials:

Tape (E388)

Personnel Required:

Medium Helicopter Repairer

References:

Task 2-2
 Task 10-51
 Task 10-53
 Task 10-69
 Task 10-79

Equipment Condition:

Battery Disconnected (Task 1-39)
 Electrical Power Off
 Helicopter Grounded (Task 1-29)
 Fuel Tank Defueled (Task 10-34 or 10-35)
 Two Tank Drain Valves Removed (Task 10-39)

General Safety Instructions:**WARNING**

All regulations and instructions on handling fuels shall be strictly observed.

NOTE

Air purging forces fresh air into the defueled tank to replace fuel vapors.

Procedure is same to purge any fuel tank. No. 1 (left) main fuel tank purging is shown here.

1. Connect air supply hose (1) to air mover (2).
2. Open air supply valve (3) slowly.
3. Allow air supply to flow to clear hose (1) and air mover (2).
4. Close air supply valve (3).

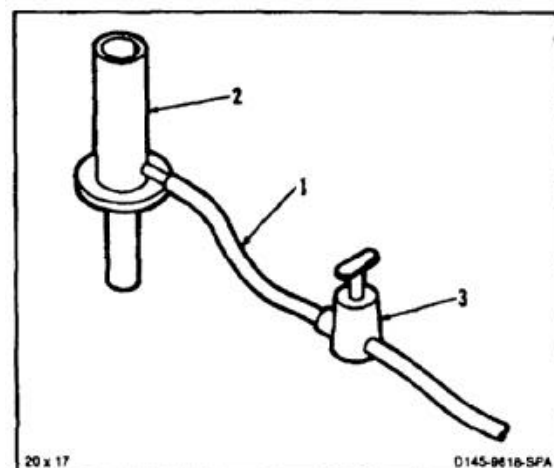
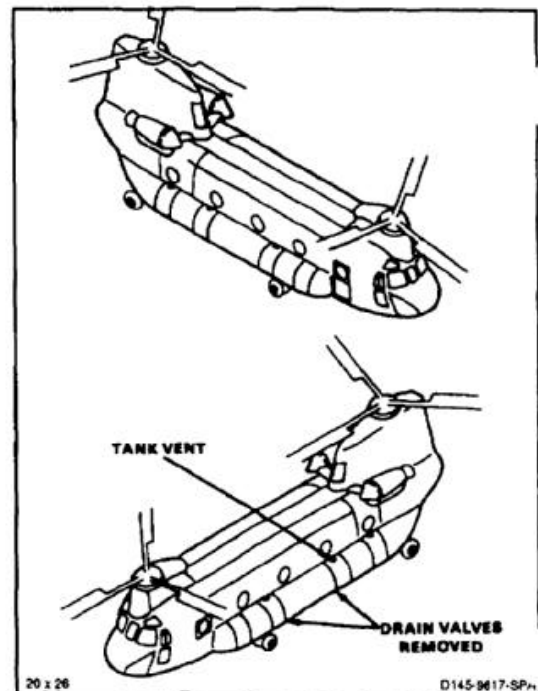

- | | |
|--|---|
| <p>5. Check that tank vent (4) and drain holes (5) are clear.</p> <p>6. Connect air mover ground receptacle (6) to aircraft plug (7).</p> <p>7. Remove fuel tank filler cap (8).</p> <p>8. Install air mover (2) into open filler hole (9). Secure mover with tape (E388).</p> | <p>9. Open air supply valve (3) fully.</p> <p>10. Test purged tank. Use combustible gas indicator. If level of fumes is still dangerous, purge until level is safe.</p> |
|--|---|

NOTE

If only the air mover is used, purging takes **24 hours**. If more rapid purging is required perform steps 11 thru 22.

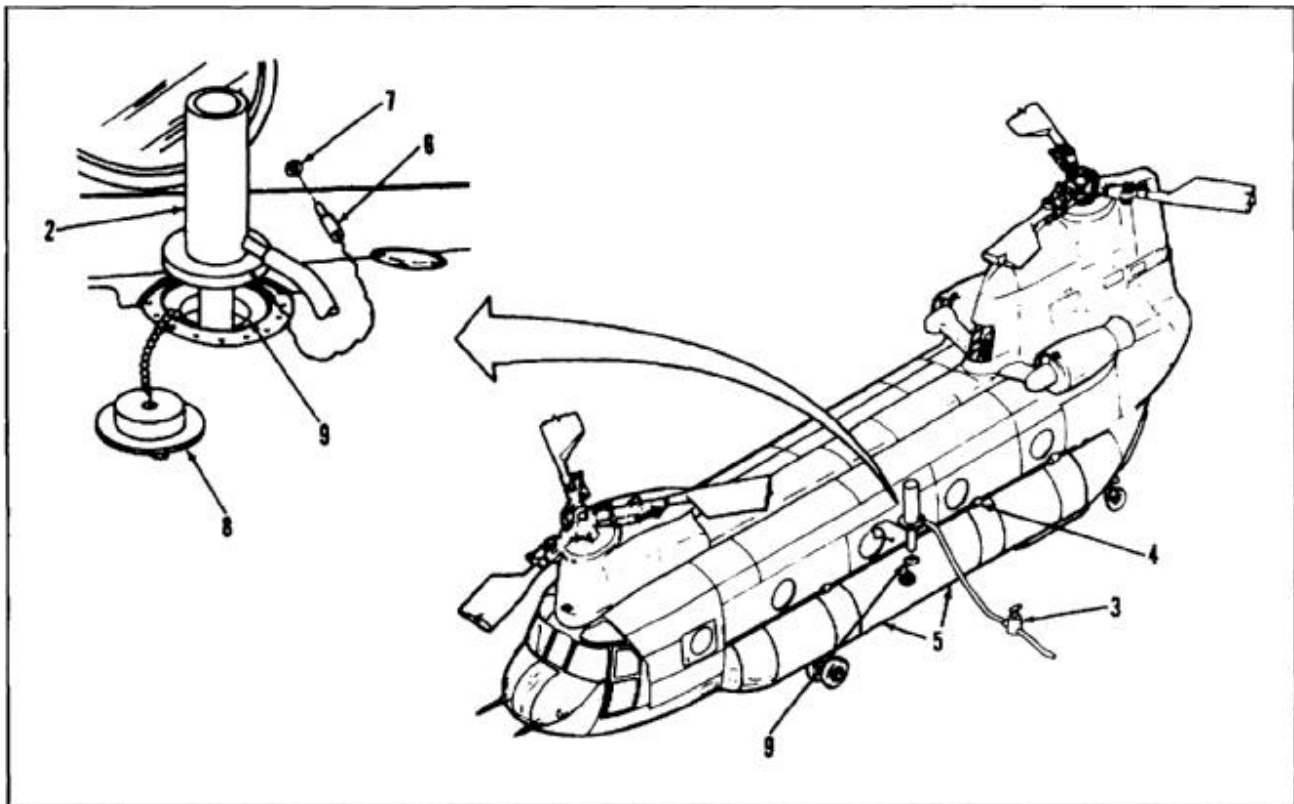

WARNING

If heater and plenum chamber are used with blower, start heater before connecting heater duct to plenum chamber.

Do not shut off air flow while air duct is attached to helicopter.

If power fails, remove duct and blower from area until normal air flow is restored.

11. Open pod access panel (10) for the tank being purged (Task 2-2).
12. Position and ground air blower (11).
13. Start blower (11) and air mover (2).
14. Connect duct (12) to blower.
15. Connect duct ground receptacle (13) to aircraft plug (14).
16. Position duct (12) to blow air at 45° angle across tank access door (15).
17. Remove tank access door (15), forward tank (Task 10-69), main tank (Task 10-51 or 10-53), and aft tank (Task 10-79).
18. Position duct (12) to blow into fuel tank (16) through access hole (15). Maintain use of air mover if working inside fuel cell.
19. After **15 minutes** remove air duct (12) from fuel tank down and remove air blower (10).
20. Test purged tank. Use a combustible gas indicator. If level of fumes is still dangerous, purge until level is safe.
21. Close supply valve (3). Remove air mover (2). Disconnect ground receptacle (6).

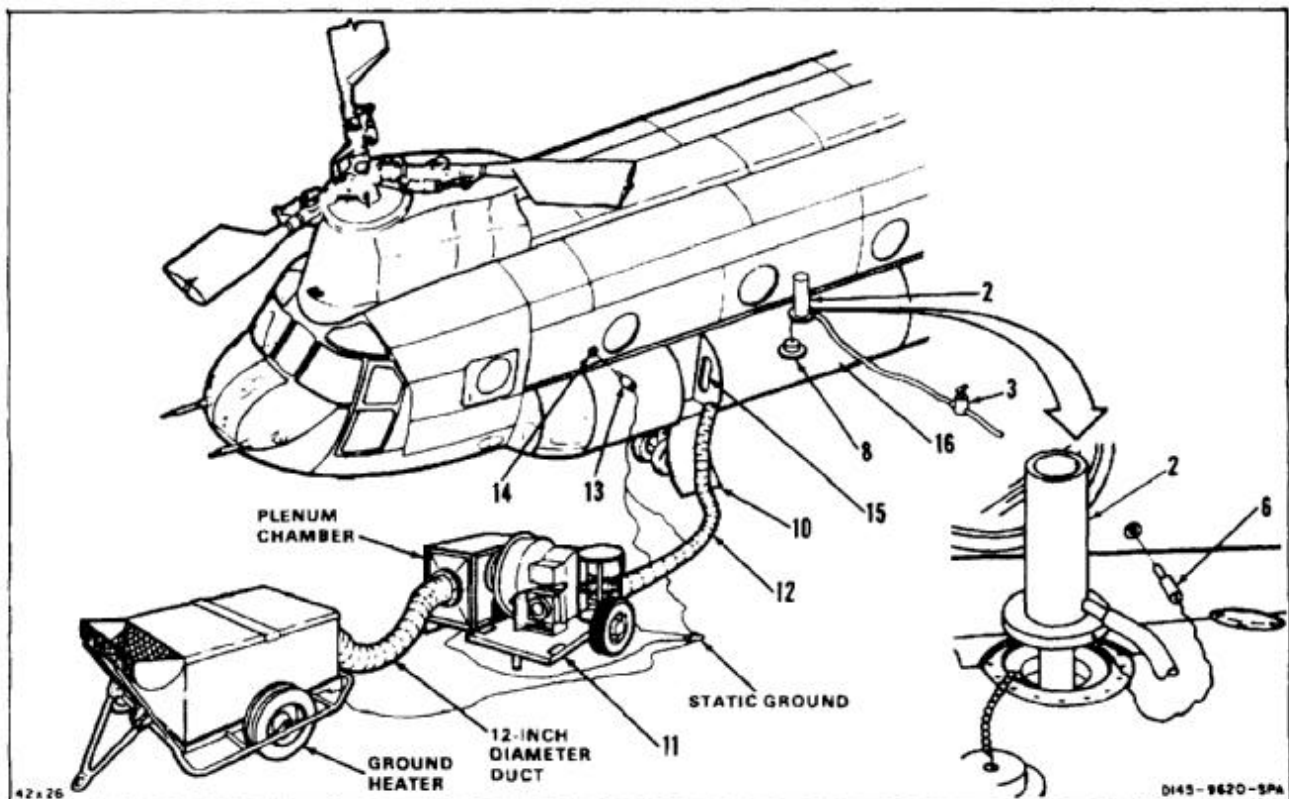

22. Install tank filler cap (8).

FOLLOW-ON MAINTENANCE:

When work on fuel tank is completed, install tank drain valves (Task 10-40).

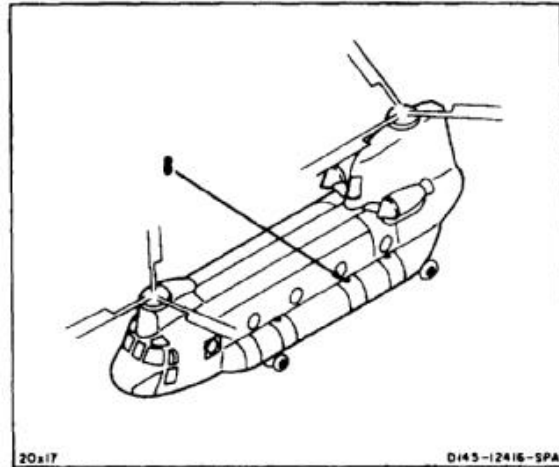

END OF TASK

INITIAL SETUP

Applicable Configurations:

All

Tools:

None

Materials:

None

Personnel Required:

Medium Helicopter Repairer (2)
Inspector

Equipment Condition:

Battery Disconnected (Task 1-39)
Electrical Power Off
Helicopter Grounded (Task 1-29)
Helicopter Defueled (Task 10-34)
Fuel Tanks Purged (Task 10-2)
Forward Landing Gear Access Panels Removed
(Tasks 2-178 and 2-180)
Aft Intertank Pod Panel Removed (Task 2-185)
Main Fuel Tank Vent Fairing Removed (Task 10-63)
Main Fuel Tanks Lowered (Task 10-6)
Forward Fuel Tanks Lowered (Task 10-23)
Aft Fuel Tanks Lowered (Task 10-28)
Main Tank Forward and Aft Access Doors Removed
(Tasks 10-51 and 10-53)
Forward Tank Forward Access Door Removed (Task
10-69)
Aft Tank Forward Access Door Removed (Task 10-79)

General Safety Instructions:**WARNING**

All regulations and instructions
for handling fuels shall be strictly
observed.

NOTE

Inspection does not require removal
of bladder from pod.

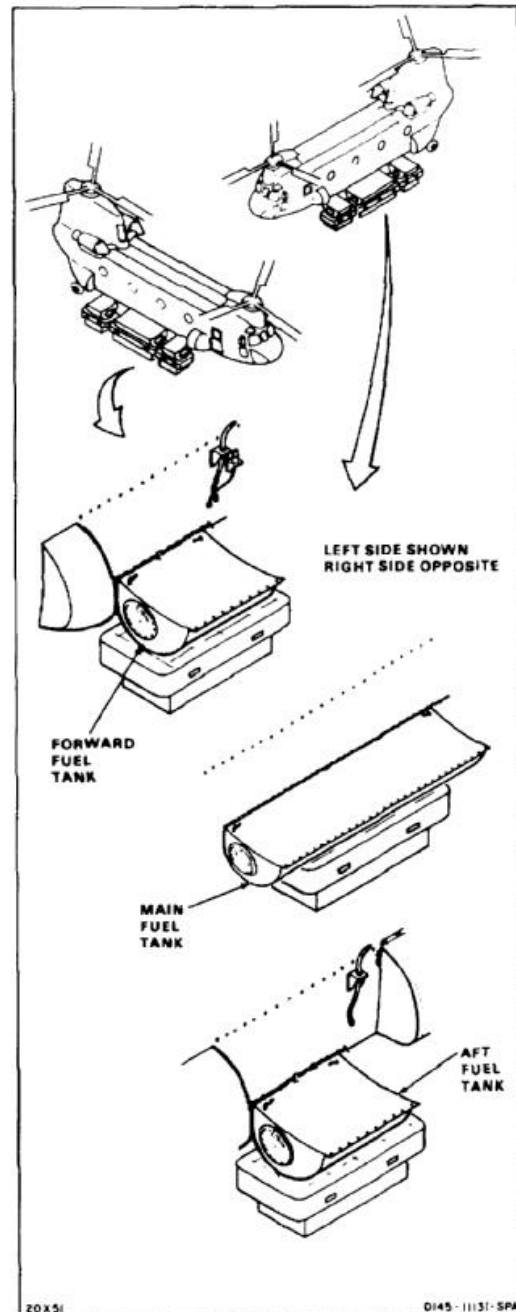

NOTE

Procedure is same to inspect left or right fuel tank assemblies. Left tanks are shown here.

INSPECT MAIN FUEL TANK

1. Check interior of main pod (1). There shall be no damage, layer separation, leakage, or contamination.
2. Check cell (2). There shall be no damage, layer separation, no fuel in self-sealing layers, and no green, sponge-like material.
3. Check interior of cell (2). Interior shall not be contaminated with mold.
4. Check exterior surfaces of cell (2). Anti-chafing tape shall be secure, and there shall be no chafing damage.
5. Check hoses, fittings, and tubing inside tank (2). There shall be no damage or deterioration.
6. Check vent drain lines (3). Lines must not have high or low spots that can trap fluid.
7. Check probes (4). Hoses and tubing must not contact probes under normal movement.

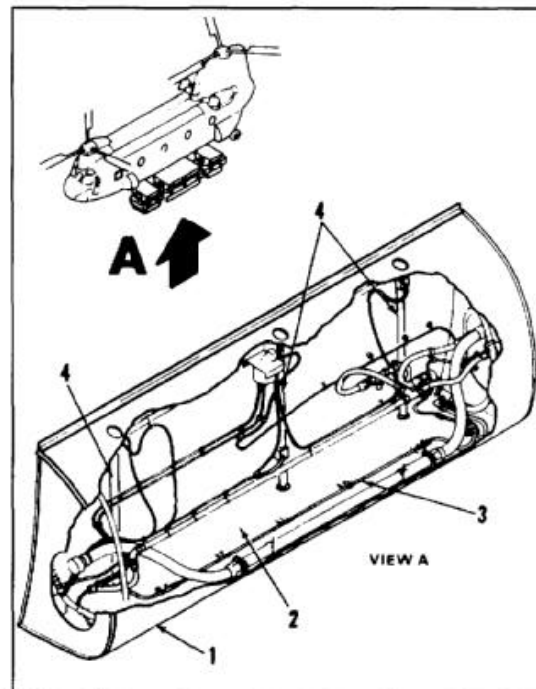
**INSPECT FORWARD FUEL TANK**

8. Check interior of forward pod (5). There shall be no damage, layer separation, leakage, or contamination.
9. Check cell (6). There shall be no damage, layer separation, no fuel in self-sealing layers, and no green, sponge-like material.
10. Check interior of cell (6). Interior shall not be contaminated with mold.
11. Check exterior surface of cell (6). Anti-chafing tape (E381) shall be secure, and there shall be no chafing damage.
12. Check hoses, fittings, and tubing inside cell (6). There shall be no damage or deterioration.
13. Check vent drain lines (7). Lines must not have high or low spots that can trap fluid.

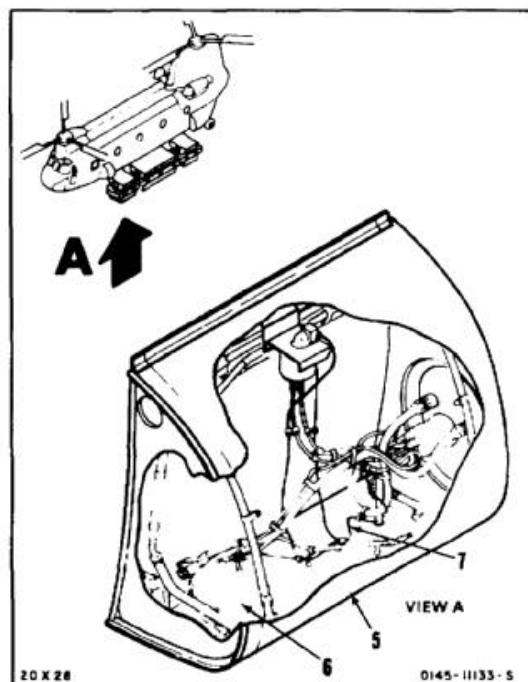

INSPECT AFT FUEL TANK

14. Check interior of aft pod (8). There shall be no damage, layer separation, leakage, or contamination.
 15. Check cell (9). There shall be no damage, layer separation, no fuel in self-sealing layers, and no green, sponge-like material.
 16. Check interior of cell (9). Interior shall not be contaminated with mold.
 17. Check exterior surface of cell (9). Anti-chafing tape shall be secure, and there shall be no chafing damage.
 18. Check hoses, fittings, and tubing inside cell (9). There shall be no damage or deterioration.
 19. Check vent drain lines (10). Lines must not have high or low spots that can trap fluid.
20. Check support structure (11). Support structure shall not be damaged.
 21. Check hinges (12) and hinge pins (13). Hinges and pins shall not be worn or damaged.

FOLLOW-ON MAINTENANCE:

- Perform vent system pressure test (Task 10-117).
- Install aft tank access doors (Task 10-80).
- Install forward tank access doors (Task 10-70).
- Install main tank access doors (Tasks 10-52 and 10-54).
- Raise and install aft fuel tanks (Task 10-31).
- Raise and install forward fuel tanks (Task 10-26).
- Raise and install main fuel tanks (Task 10-21).
- Install main fuel tank vent fairings (Task 10-64).
- Perform vent system flow test (Task 10-118).
- Perform test of pressure refueling system (Task 10-119) and fuel feed system (Task 10-120).
- Install aft intertank pod panels (Task 2-188).
- Close forward landing gear access panels (Task 2-179 and 2-181).
- Service fuel tanks (Task 1-51).
- Bleed fuel system (Task 10-121).

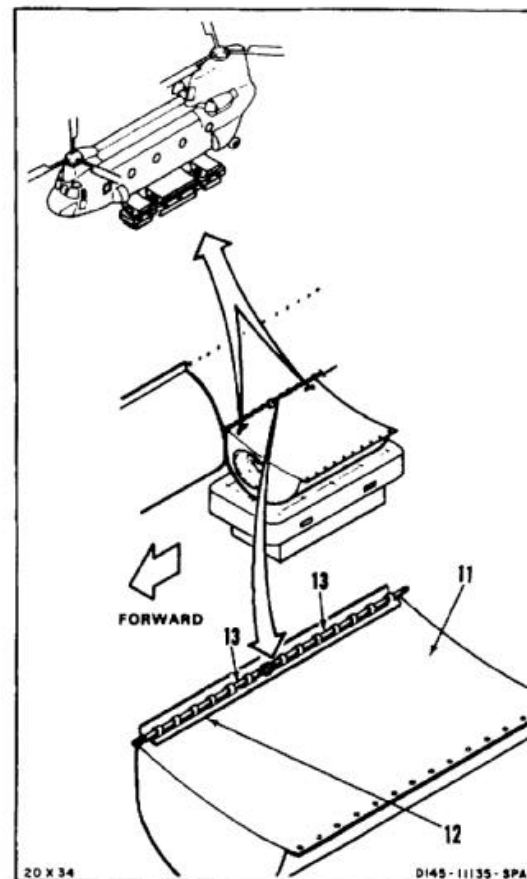
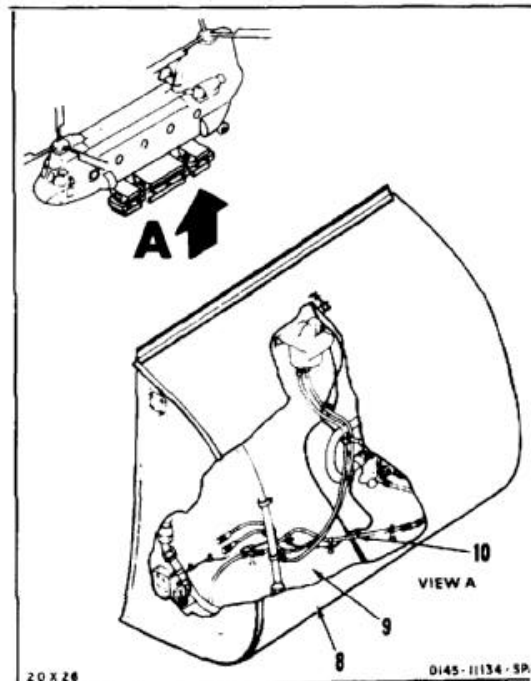

END OF TASK

INITIAL SETUP

Applicable Configurations:

All

Tools:

None

Materials:

None

Personnel Required:

Medium Helicopter Repairer
Inspector

References:

Task 10-118
TM 55-1520-240-T

Equipment Condition:

Battery Disconnected (Task 1-39)
Electrical Power Off
Hydraulic Power Off
Helicopter Grounded (Task 1-29)
Aft Intertank Pod Panels Opened (Task 2-185)
Forward Landing Gear Access Doors Opened (Task 2-2)

General Safety Instructions:



All regulations and instructions for handling fuels shall be strictly observed.

NOTE

Procedure is similar to inspect either main fuel tank after suspected hard landing. Left side tank is shown here.

INSPECT MAIN FUEL TANK

1. Check main fuel tank (1) as follows:
 - a. Check forward access door (2). Door shall be secure, and there shall be no missing bolts (3).

NOTE

Fittings in doors will shear under high loads.

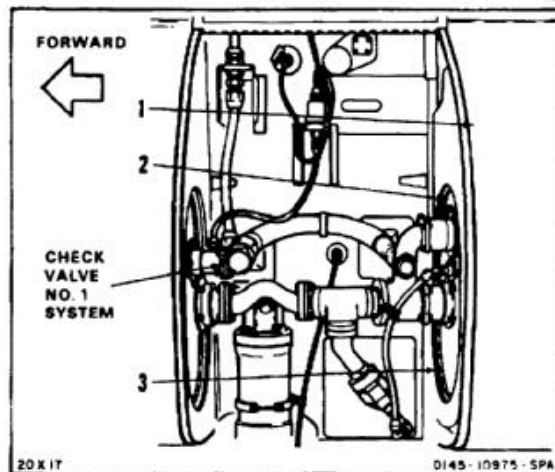
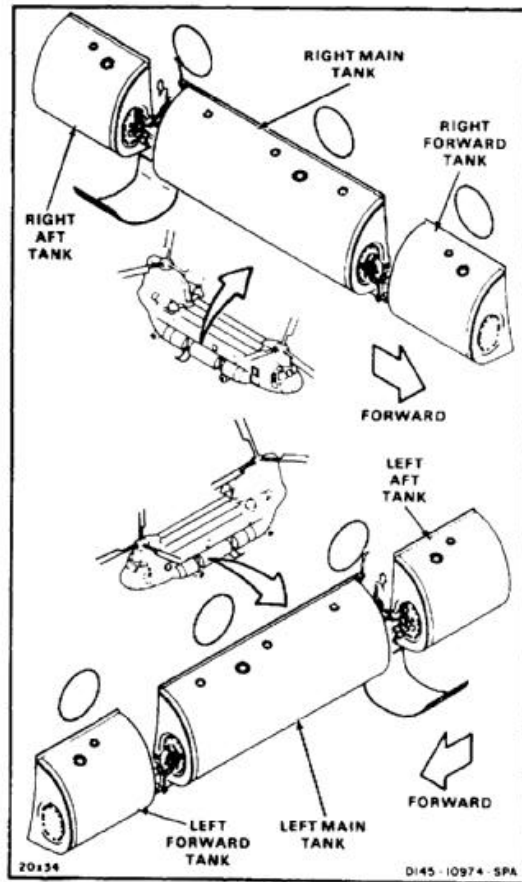

10-5 INSPECT FUEL TANKS — HARD LANDING (Continued)

10-5

- b. Check forward breakaway fittings (4 and 5). Fittings shall be secure.
- c. Check manifold (6), tee (7), and two elbows (8). Manifold, tee, and two elbows shall be secure.
- d. Check aft breakaway fittings (9, 10, and 11). Fittings shall be secure.
- e. Check areas around three tank units (12) and tank filler adapter (13). There shall be no missing rivets.

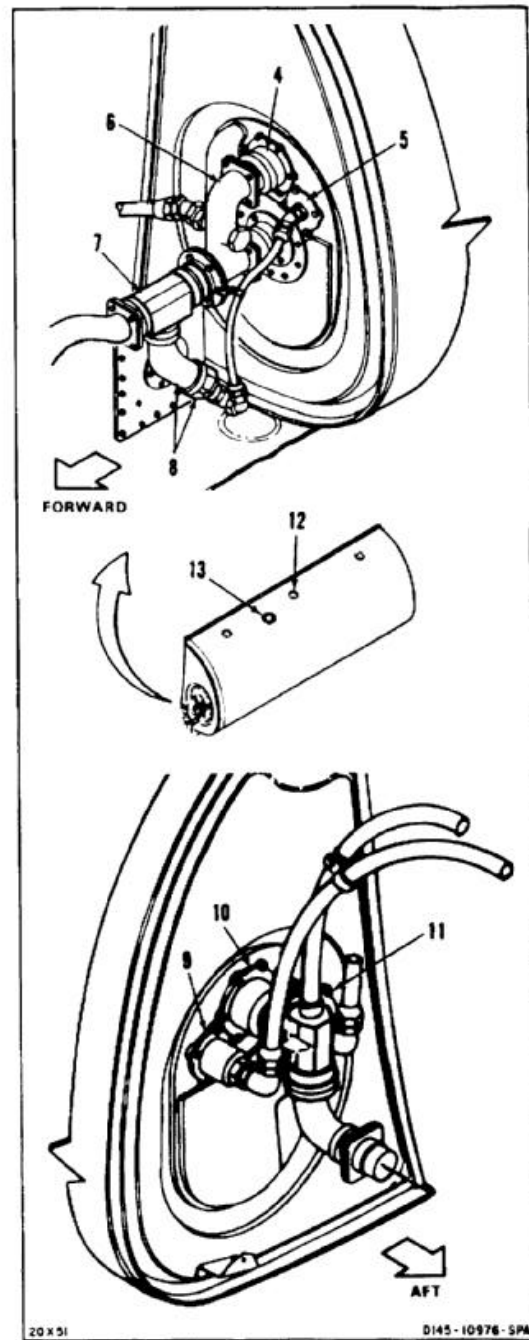

- f. Check two lanyard-release electrical connectors (14). Connectors shall be secure.

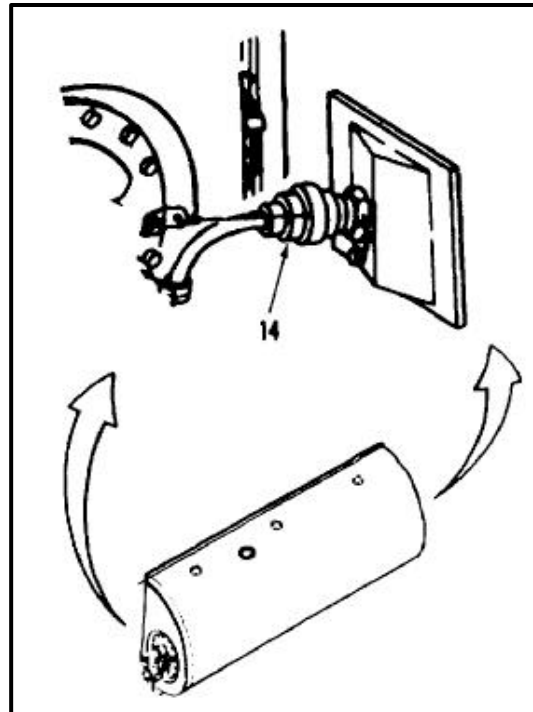

INSPECT FORWARD FUEL TANK

NOTE

Procedure is same to inspect either forward fuel tank after suspected hard landing. Left side is shown here.

2. Check forward fuel tank (15) as follows:
 - a. Check access door (16) on aft end of tank (15). Door shall be secure and there shall be no missing bolts (17).
 - b. Check fittings (18, 19, and 20) on aft end of tank (15). Fittings shall be secure.
 - c. Check access door (21) on forward end of tank. Door shall be secure and there shall be no missing bolts (22).
 - d. Check areas around tank unit (23) and tank filler adapter (24). There shall be no missing rivets.
 - e. Check lanyard-release electrical connector (25). Connector shall be secure.

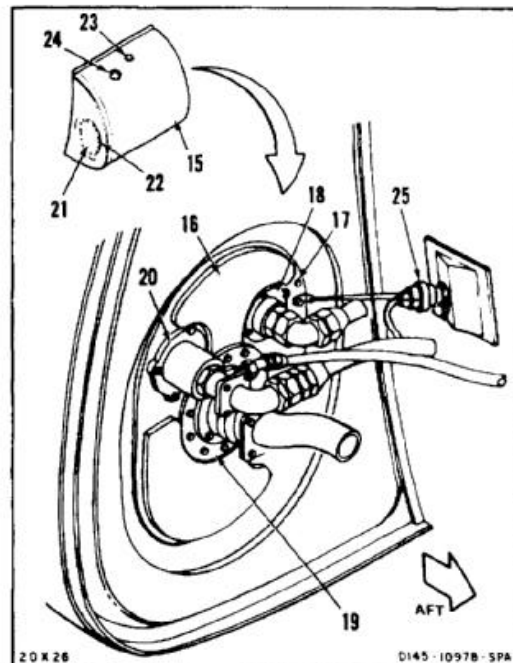

INSPECT AFT FUEL TANK**NOTE**

Procedure is same to inspect either aft fuel tank after suspected hard landing. Right side tank is shown here.

3. Check aft fuel tank (26) as follows:
 - a. Check access door (27) on forward end of tank (26). Door shall be secure, and there shall be no missing bolts (28).
 - b. Check fittings (29 and 30) on forward end of aft tank (26). Fittings shall be secure.
 - c. Check auxiliary power unit pump (31) and valve (32) on left aft tank (26) only. Pump and valve shall be secure.
 - d. Check tee (33), elbow (34), and valve (35). Tee, elbow, and valve shall be secure.
 - e. Check access door (36) on aft end of aft tank (26). Door shall be secure, and there shall be no missing bolts (37).
 - f. Check fitting (38) on aft end of aft tank (26). Fitting shall be secure.
 - g. Check areas around tank unit (39) and tank filler adapter (40). There shall be no missing rivets.
 - h. Check lanyard-release electrical connector (41). Connector shall be secure.

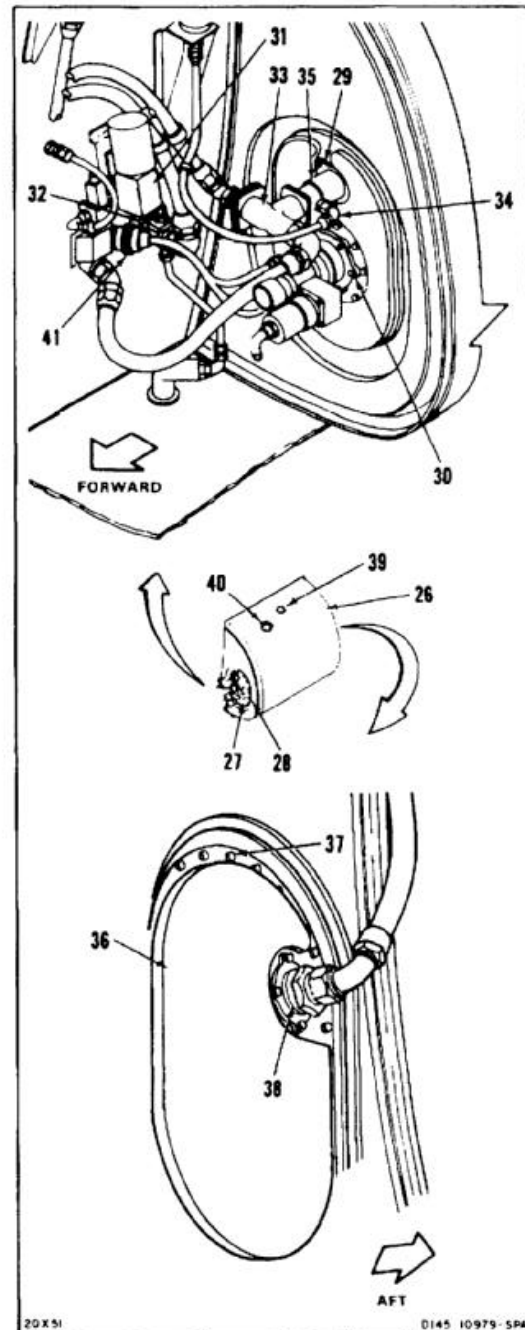

4. Repeat step 1 for other main tank (1).
5. Repeat step 2 for other forward tank (15).
6. Repeat step 3 for other aft tank (26).
7. Perform vent system flow check (Task 10-118).
8. Perform boost pump operational check (TM 55-1520-240-T). Check L FUEL PRESS or R FUEL PRESS lights on master caution panel. If light stays on, this indicates fitting failure in engine feed line on main tank (1). If AUX PRESS light stays on, this indicates fitting failure in transfer line from forward or aft tank (15 or 26).
9. Check all hoses and tubes. Hoses and tubes shall be secure.

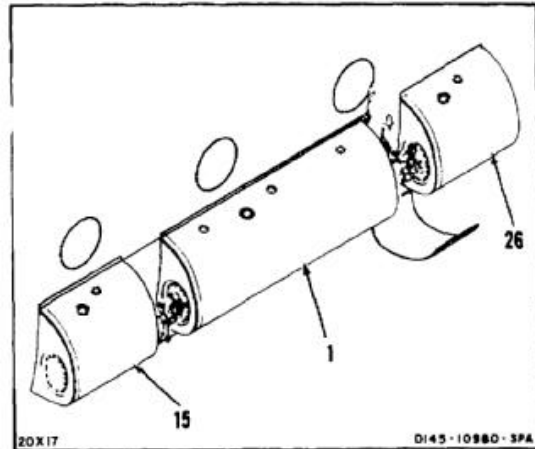
**INSPECT****FOLLOW-ON MAINTENANCE:**

- Perform vent system flow test (Task 10-118).
- Perform test of pressure refueling system (Task 10-119) and fuel feed system (Task 10-120).
- Inspect left intertank pod panels (Task 2-188).
- Close forward landing gear access doors (Task 2-2).

END OF TASK

INITIAL SETUP

Applicable Configurations:

All

Tools:

Aircraft Mechanic's Tool Kit, NSN 5180-00-323-4692
 Padded Support
 Wrench, Open End, 1-1/2 Inch
 Wrench, Open End, 1-7/8 Inch
 Grounded Container, 2 Quart

Materials:

Cloths (E135)
 Penetrating Lubricant (E236)
 Barrier Material (E80)
 Tape (E388)

Personnel Required:

Medium Helicopter Repairer (2)

Equipment Condition:

Battery Disconnected (Task 1-39)
 Electrical Power Off
 Helicopter Grounded (Task 1-29)
 Main Fuel Tank Defueled (Task 10-34 or 10-35)
 Forward Landing Gear Access Panel Removed (Task 2-178 or 2-180)
 Aft Intertank Pod Panel Opened (Task 2-185)
 Main Fuel Tank Vent Fairing Removed (Task 10-63)
 Fuel Tank Purged (Task 10-2)

General Safety Instructions:**WARNING**

All regulations and instructions for handling fuels shall be strictly observed.

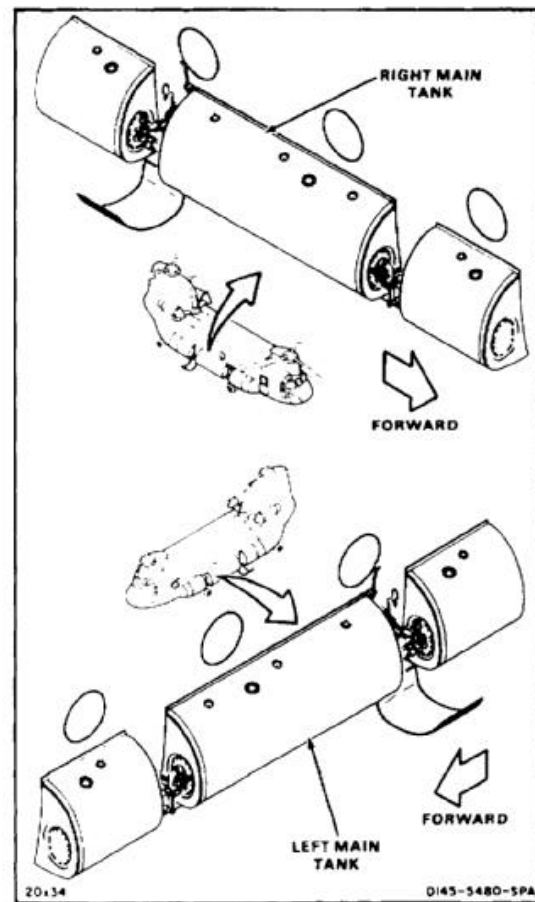

NOTE

Procedure is same to remove main fuel tank in No. 1 or No. 2 fuel system. Removal of No. 1 (left) tank is shown here.

LOWER MAIN FUEL TANK ON HINGES

1. Disconnect electrical connector (1).
- 1.1. Disconnect hook (1.1) from lanyard on electrical connector (1).



When disconnecting fuel hoses from access door, do not allow fittings to turn. Otherwise, access door fittings can fall and cause fuel blockage.

2. Hold filling (2) with wrench and disconnect hose (3). Catch spilled fuel. Use grounded container. Plug hose and cap filling.
3. Remove eight nuts (4), washers (5) and bolts (6). Remove hose clamp (3.1) from the lower flange.
4. Slide manifold (7) forward into adapter (8).
5. Remove gaskets (9 and 10).

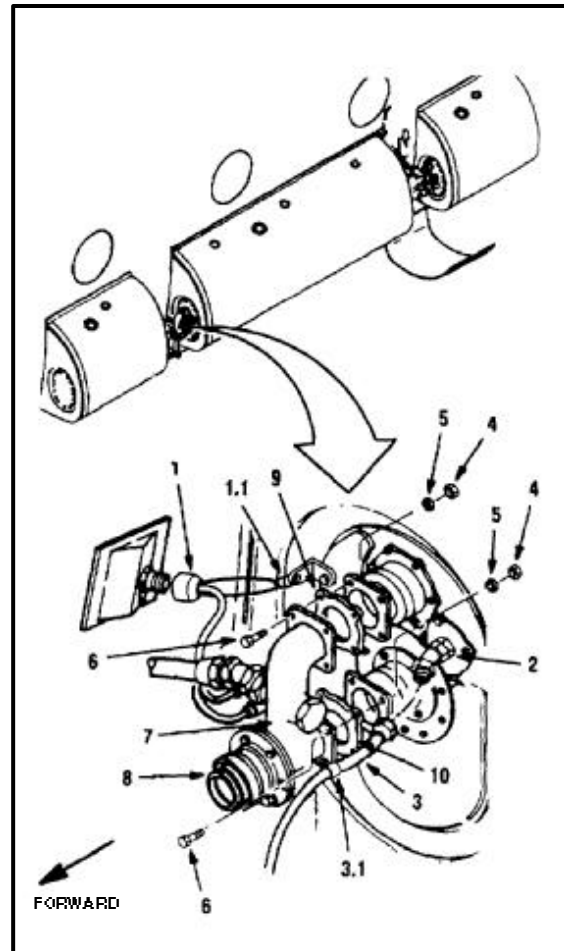

6. Disconnect electrical connector (11).
- 6.1. Disconnect hook (11.1) from the lanyard on electrical connector (11).

CAUTION

Do not allow elbow or fittings to turn when disconnecting fuel hoses from fittings on aft access panel. Otherwise, access door fittings can fail and cause fuel blockage.

7. Hold fitting (12) with wrench and disconnect hose (13). Catch spilled fuel. Use grounded container. Remove conical seal (13.1). Plug hose and cap fitting.
8. Hold fitting (14) with wrench and disconnect hose (15). Plug hose and cap fitting.
9. Hold tee (16) with wrench and disconnect hose (17). Remove conical seal (17.1). Plug hose and cap tee.
10. Remove four nuts (18), washers (19) and bolts (20).
11. Slide elbow (21) aft into adapter (22). Remove gasket (23).
12. Remove four nuts (24), washers (25), and bolts (26).
13. Remove elbow (21), tee (16), and gasket (27).
14. Cover holes in flanges (28 and 29). Use barrier material (E80) and tape (E388).

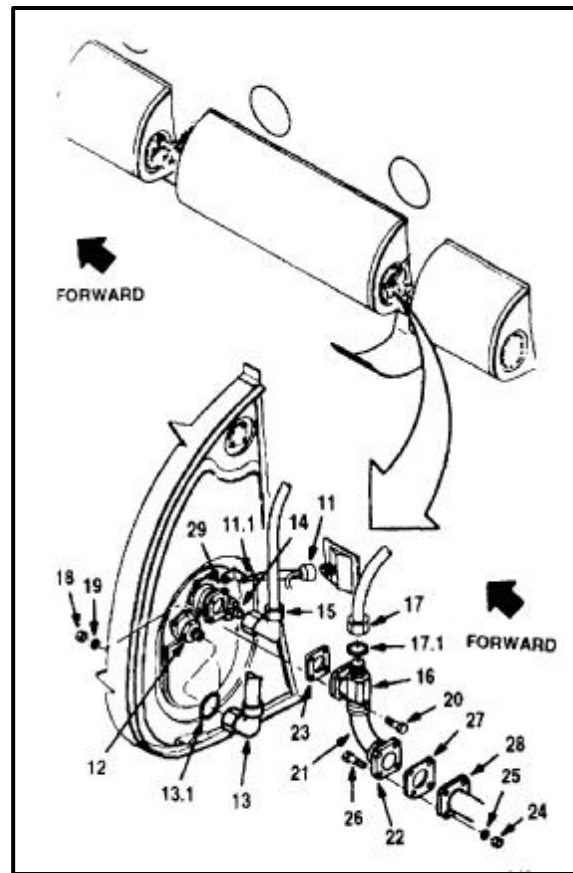

15. Position padded support (30) at side of tank (31). Top of support should be approximately **24 inches** below bottom of fuselage.
16. Remove four bolts (32) and washers (33).
17. With aid from helpers, support tank (31). Remove 37 bolts (34) and washers (35).
18. Lower tank (31) on hinge (36) onto padded support (30).

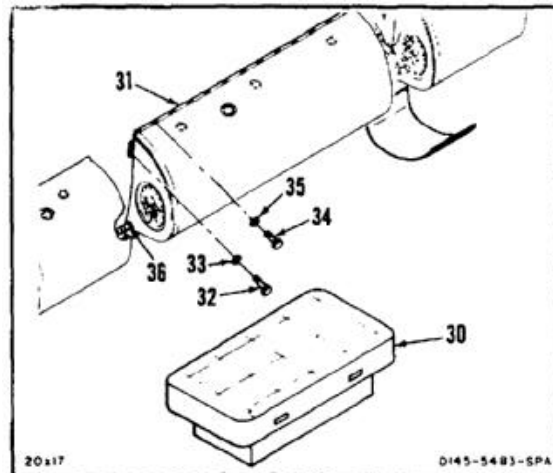

REMOVE MAIN FUEL TANK

19. Remove two straps (37) securing sleeves (38).
20. Disconnect two cable plugs (39).
21. Spray hinge (36) with penetrating lubricant (E236).
22. Remove lockwire at five places (40) and remove four hinge pins (41, 42, 43 and 44).
23. Remove tank (31).
24. Clean up spilled fuel. Use cloths (E135).

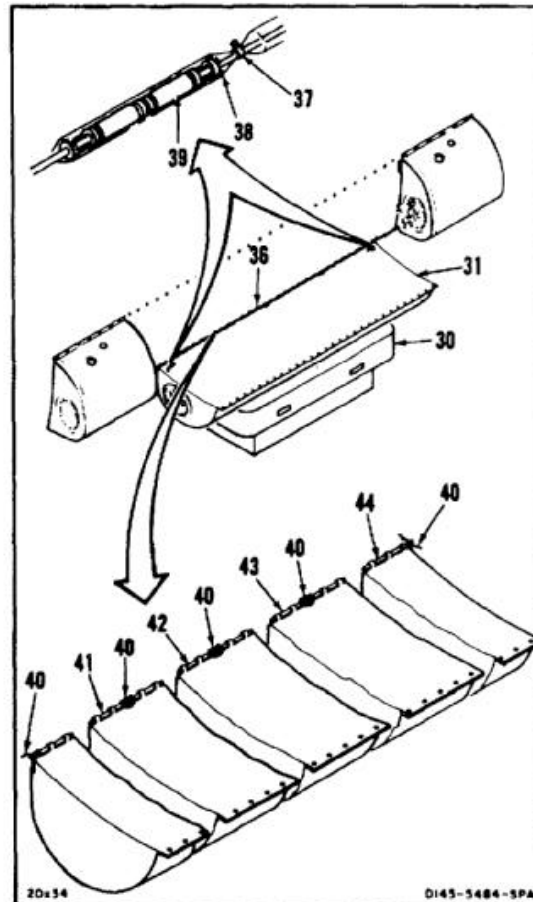

FOLLOW-ON MAINTENANCE:

None

END OF TASK

10-7 REMOVE MAIN FUEL TANK CELL**10-7****INITIAL SETUP****Applicable Configurations:**

All

Tools:

Aircraft Mechanic's Tool Kit, NSN 5180-00-323-4692

Materials:

None

Personnel Required:

Medium Helicopter Repairer

Equipment Condition:

- Main Fuel Tank Removed (Task 10-6)
- Main Fuel Tank Forward Boost Pump and Check Valve Removed (Task 10-51)
- Main Fuel Tank Aft Boost Pump and Check Valve Removed (Task 10-53)
- Main Tank Fuel Lines and Electrical Wiring Removed (Task 10-41)
- Main Fuel Tank Vent Assembly Removed (Task 10-43)
- Fuel Level Control Valve and Mounting Bracket Removed (Task 10-59)
- Tank Drain Valves Removed (Task 10-39)

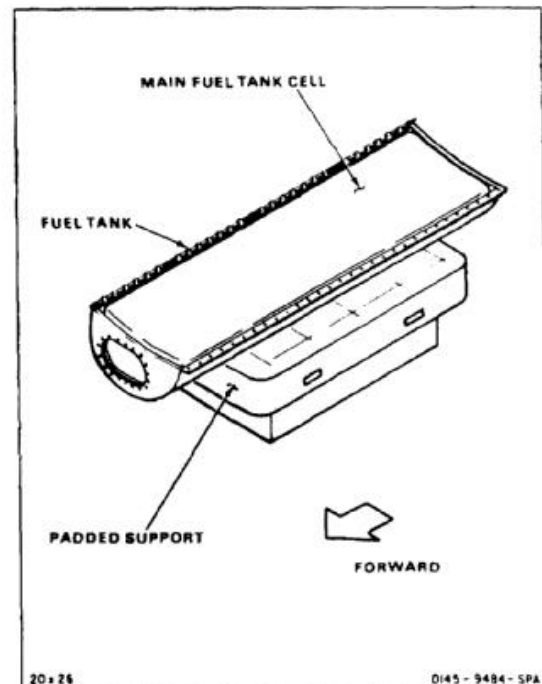
**General Safety Instructions:****WARNING**

All regulations and instructions for handling fuel shall be strictly observed.

CAUTION

Do not puncture or scratch lining of fuel cell. If lining is broken, fuel penetrates and activates self sealing layers. Activated layers swell and trap fuel. Activated green spongy material also contaminates fuel system. This makes it necessary to replace fuel cell and flush fuel system.

NOTE

Procedure is same to remove cell from No. 1 or No. 2 fuel tank. Removal of No. 1 (left) cell is shown here.

REMOVE TWO BOOST PUMP BRACKETS**NOTE**

Procedure is same to remove forward and aft boost pump mounting bracket. Removal of forward mounting bracket is shown here.

1. Remove four bolts (1) and washers (2).
2. Remove pump bracket (3). Remove flange assembly (4) on aft pump bracket.

NOTE

Four different types of main fuel cells are used on the helicopter. Each is interchangeable and there may be washers or bushings installed between pump bracket and cell.

3. Remove four washers (5) or bushings (6) as necessary.
4. Remove four bolts (8) and washers (9).
5. Remove packing (10) between fuel pod (11) and fuel cell (12).

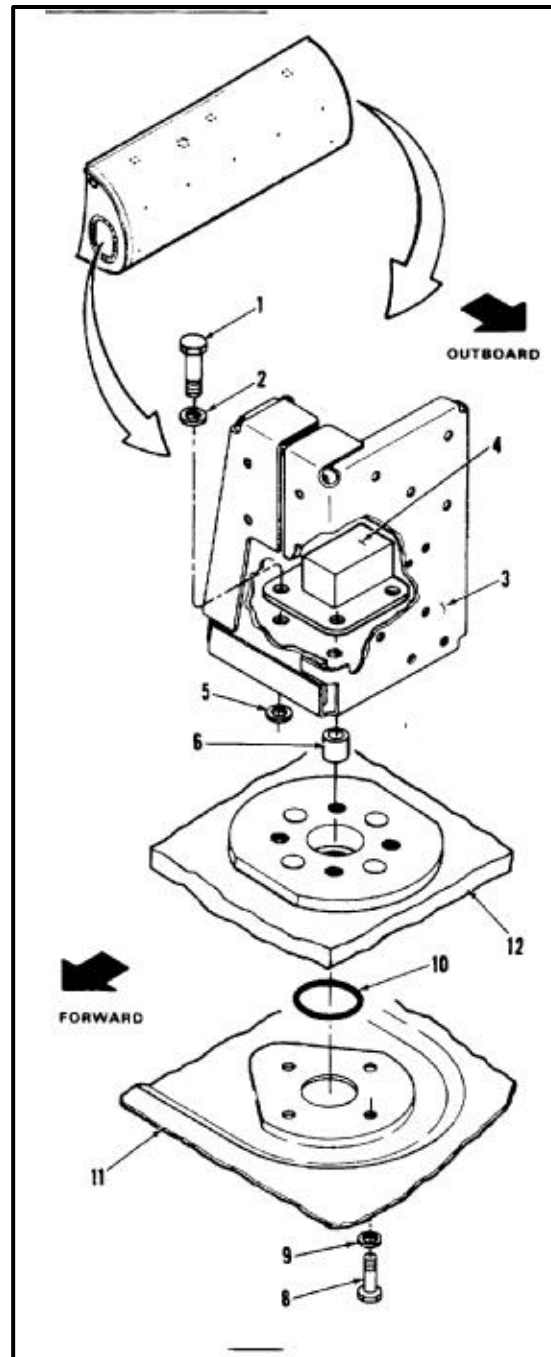

10-7 REMOVE MAIN FUEL TANK CELL (Continued)

6. Remove four bolts (13) and washers (14). Remove closure plate (15) and packing (16) at each end.
7. Remove two screws (17) and packing (18) at each end.
8. Remove four screws (19). Remove gasket (20) between fuel pod (11) and fuel cell (12).

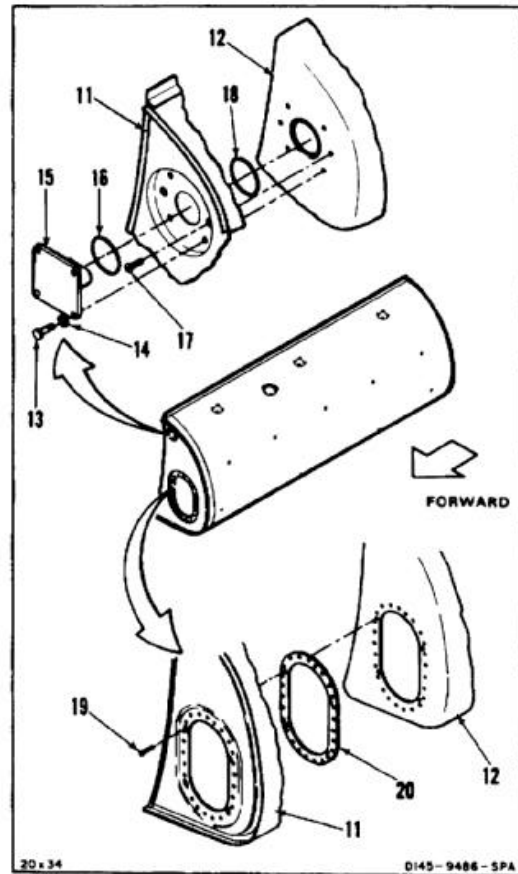

9. Remove six screws (21). Separate fuel cell (12) from fuel pod (11). Remove three gaskets (22).
10. Remove six bolts (23) and washers (24).
11. Remove filler adapter assembly (25) and gasket (26).
12. Remove three screws (27). Separate fuel cell (12) from fuel pod (11). Remove packing (28).
13. Remove five bolts (29) and washers (30).

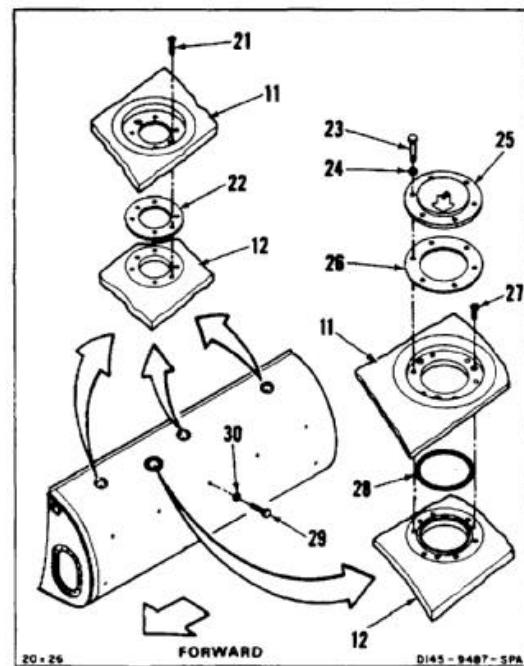

14. Carefully remove fuel tank cell (12) from pod structure (11).

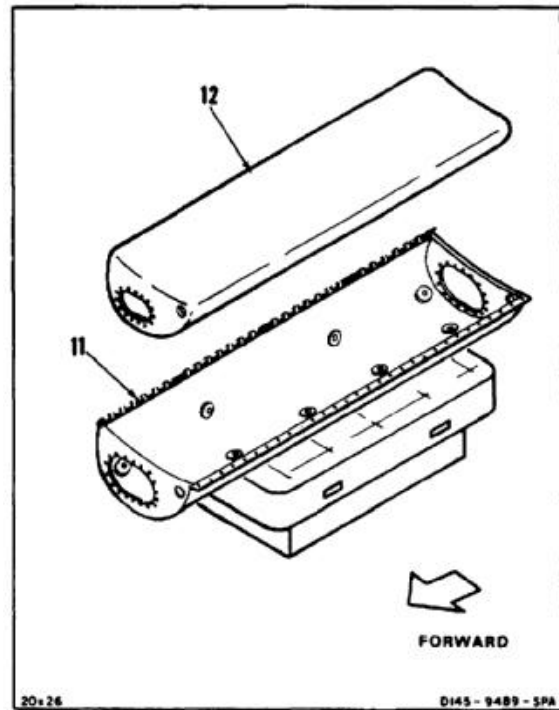

FOLLOW-ON MAINTENANCE:

None

END OF TASK

INITIAL SETUP

Applicable Configurations:

All

Tools:

Aircraft Mechanic's Tool Kit, NSN 51 80-00-323-4692

Materials:

Cloths (E135)
 Vinegar (E436)
 Barrier Material (E80)
 Tape (E388)

Personnel Required:

Medium Helicopter Repairer
 Inspector

Equipment Condition:

As Required



Do not puncture or scratch lining of fuel tank. If lining is broken, fuel penetrates and activates self-sealing layers. Activated layers swell and trap fuel. Activated green spongy material also contaminates fuel system. This makes it necessary to replace fuel tank and flush fuel system.

1. Wash contaminated area of tank. Use cloths (E135) wet with a **50-50** solution of water and vinegar (E436).

2. Wipe cleaned area dry. Use cloths (E135).
3. Make sure interior of cell is free of lint and other foreign material.

INSPECT

4. Cover all holes in cell. Use barrier material (E80) and tape (E388) as necessary.

FOLLOW-ON MAINTENANCE:

None

END OF TASK

INITIAL SETUP

Applicable Configurations:

All

Tools:

None

Materials:

None

Personnel Required:

Medium Helicopter Repairer (2)
Inspector

References:

Task 10-18

Equipment Condition:

As Required

WARNING

All regulations and instructions for handling fuels shall be strictly observed.

1. The following precautions shall be observed before and during removal, cleaning, repair and testing of fuel tank cells.

CAUTION

Do not puncture or scratch lining of fuel cell. If lining is broken, fuel penetrates and activates self-sealing layers. Activated layers swell and trap fuel. Activated green spongy material also contaminates fuel system. This makes it necessary to replace fuel cell and flush fuel system.

CAUTION

Purge fuel cell prior to removal from aircraft and/or entering the cell. Entering the fuel cell is considered to be anytime the mechanic's head is inside (including partially inside) of the fuel cell.

- a. Work only in approved areas with adequate ventilation and where emergency equipment can move freely. Initial deactivation must be done out-of-doors.

WARNING

To prevent asphyxiation from fuel, oil, and other fumes, wear protective clothing, a respirator, a full facepiece, and rubber gloves. Use an air compressor to continuously pump air into the tank when personnel are in the tank. Ground the air hose to the airframe. Assign a man to monitor the person in the tank in case he is overcome by fumes.

- b. Be careful when handling fuel cell at temperatures below **20°F (-6.67°C)** to prevent cracking molded sections.
- c. Make sure fuel cell and all cleaning, repair, and test equipment are properly grounded.
- d. Do not enter cell unless another man is available as safety monitor.
- e. Do not enter fuel cell unless wearing shoes and with no tools in your pockets.
- f. Do not enter fuel cell with tools in your pockets.
- g. Do not allow hot work lamps to contact fuel cell. If possible, use fluorescent lamps for work inside cell.
- h. Do not expose fuel cell to any source of strong light for a long period.
- i. Protect fuel cell at all times from sharp objects and from extremes of temperature and humidity.
- j. Preserve any fuel cell that will not be returned to service in **10 days** to prevent cracking of inner walk (Task 10-18).

FOLLOW-ON MAINTENANCE:

As Required

END OF TASK

10-10 FUEL CELL DAMAGE — CLASSIFICATION AND REPAIR LIMITS (GENERAL INFORMATION)

10-10

INITIAL SETUP**Applicable Configurations:**

All

Tools:

None

Materials:

Repair Cement — 2 Part Set (E63.2)

Personnel Required:

Inspector

References:

Task 10-7
 Task 10-8
 Task 10-11
 Task 10-12
 Task 10-15
 Task 10-15.1
 Task 10-24
 Task 10-29

Equipment Condition:

Off Helicopter



Remove fuel cell from helicopter and clean before doing any repair (Task 10-7, 10-24 or 10-29 and 10-8).

1. Classify fuel cell damage as follows:

MINOR DAMAGE

2. No repair is required if damage is confined to:
 - a. Blisters less than **1 inch** diameter.
 - b. Loose lap seam with **1 inch** (minimum) effective seal after removal of loose edges.

REPARABLE DAMAGE

3. Damage that is reparable is classified as follows:
 - a. Blister Damage. Blisters exceeding **1 inch** diameter must be repaired. Cut away the blister and apply an internal or an external cement repair, depending upon the blister location (Tasks 10-11 and 10-15).
 - b. Loose Seam Damage. A loose seam having less than **1 inch** of effective seal must be repaired. Remove the loose edges and apply an internal or an external reinforced cover patch depending upon the loose seam location (Tasks 10-12 and 10-15.1).

- c. Cuts, Tears, Chafing or Snag Damage. All cuts, tears, chafing and snags occurring to but not penetrating inner liner or outer coating must be repaired. Trim the damaged area and apply an internal or an external cement repair, depending upon the damage location (Tasks 10-11 and 10-15).
- d. Cuts, Tears, Snags, and Holes. All cuts, tears, snags and holes (not including holes which penetrate the entire cell wall) penetrating one or more plies require an internal and external reinforced cover patch, depending on location. Repair is limited to damages not exceeding a length or diameter of **4 inches** after trimming. Remove loose material and ragged edges. Apply external patch first (Tasks 10-12 and 10-15.1).
- e. Hole Damage. Holes which penetrate the entire cell wall without sealant activation and do not exceed a length of **4 inches**. Apply external patch first (Tasks 10-12 and 10-15.1).
- f. Loose Fitting Flange Damage (Internal and External). Clean and buff contact surfaces. Cement surfaces with repair cement (E63.2) (Tasks 10-11 and 10-15).
- g. Replacement of fitting thread inserts (helicoils) (TM 1-1500-204-23).

10-10 FUEL CELL DAMAGE — CLASSIFICATION AND REPAIR LIMITS (GENERAL INFORMATION) (Continued)

10-10

- h. Deleted.
- i. Repair/Replacement of Internal and External Support Fittings (Task 10-12 or 10-15.1). Task 10-12 (exterior) or 10-15.1 (interior) shall be used with the following changes:
 - (1) Omit step 1d as the support fitting is the patch.
 - (2) Omit steps 1h/1m, 1i/1n, and 1j/1o from Tasks 10-12 and 10-15.1 respectively, and incorporate: Apply one uniform brush coat of repair cement (E63.2) to the prepared bonding surface of the support fitting and to the cell wall. Carefully position the support fitting in the proper location and press down firmly with finger pressure to force out any trapped air. Make sure fitting does not move off location during cure.

NON-REPARABLE DAMAGE

- 4. Damage that is not reparable is classified as follows:
 - a. Damage which extends into a corner or step off area that involves a cut longer than **4 inches** is not reparable.
 - b. Damage which has led to activation of the sealant ply/plies is not reparable.
 - c. Damage to cells which cannot be repaired by cement or reinforced patching is not reparable.

FOLLOW ON MAINTENANCE:

None

END OF TASK

INITIAL SETUP

Applicable Configurations:

All

Tools:

All Required
 Portable Drill, Pneumatic, NSN 5130-00-293-1978
 Abrasive Arbor, 1/4 Drive, 1 Inch Diameter, 1 Inch
 Long, Dunmore Model R421003 or Equivalent

Materials:

Emery Cloth (E123)
 Methyl-Ethyl-Ketone (E244)
 Repair Cement — 2 Part Set (E63.2)
 Wooden Tongue Depressor (E424)
 Scotch-Brite (E2)
 Gloves (E184.1 and E186)

Personnel Required:

Aircraft Structural Repairer
 Inspector

References:

None

Equipment Condition:

As Required

General Safety Instructions:**WARNING**

Methyl-ethyl-ketone (E244) and repair cement (E63.2) and its components are flammable and toxic. They can irritate skin and cause burns. Use only with adequate ventilation, away from heat or open flame. Avoid contact with skin, eyes, or clothing. In case of contact, immediately flush skin or eyes with water for at least **15 minutes**. Get medical attention for eyes.

1. Repair blisters, cuts, tears, snags and abrasions that damage but do not penetrate the outer reinforcement plies (No Fabric Damage) as follows.
 - a. Trim away loose, damaged or blistered outer coating.
 - a.1. Clean damaged area using a clean cloth dampened with MEK (E244). Wear gloves (E184.1)

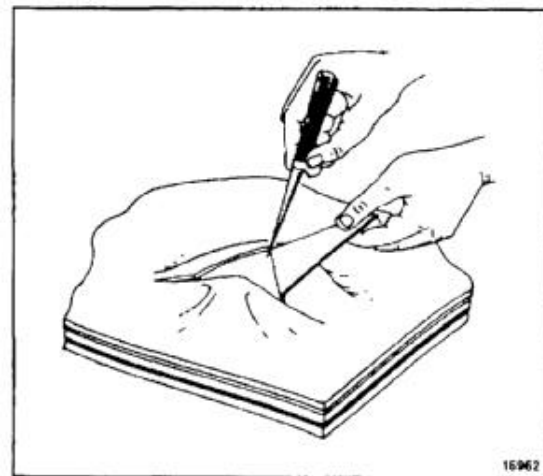

- b. Buff surface around damage **3/4 inch** larger in all directions than damaged area (1). Use portable drill (2), abrasive arbor, and/or scotch-brite (E2). Buff only to remove gloss without excessively reducing outer coating thickness.
- c. Clean buffed area. Use a clean cloth (E120) dampened with MEK (E244). Wear gloves (E184.1).
- d. Prepare repair cement (E63.2) by blending the two ingredients of part 2 (E63.5) together first and then transfer the entire contents of part 2 into the can of part 1 (E63.4). Wear gloves (E186).

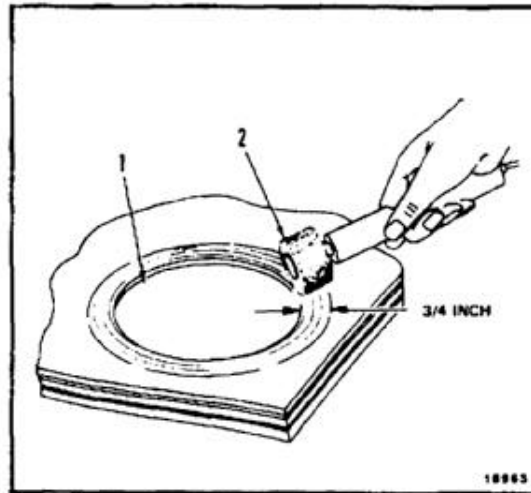

Unmixed cement will not cure.

- e. Stir cement mixture with tongue depressor (E424) for approximately **5 minutes**. Make certain components are completely blended together.
- f. Carefully apply a thin uniform coat of cement mixture (3) over buffed area (4) to no more than **1/4 inch** of O.D. of buffed area. Use a brush. Smooth surface with gloved fingers wet with MEK (E244). Remove any excess cement from unbuffed area. Use clean cloth (E120) dampened with MEK (E244). Wear gloves (E184.1).

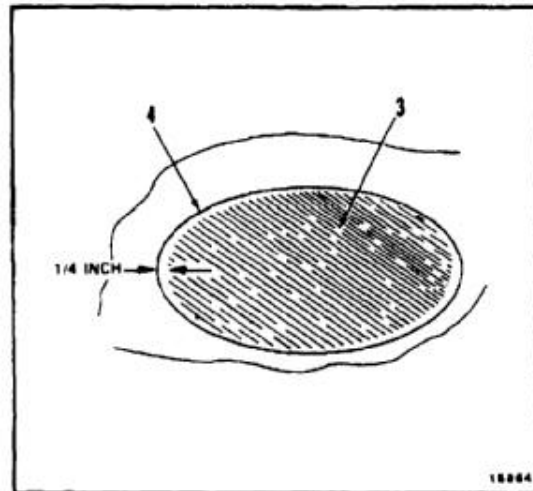

Do not flex fuel cell in repair area.

- g. Allow finished repair to set for **1 hour** before moving fuel cell.
- h. Allow finished repair to air cure for **24 hours** at room temperature of **70°F (33°C)** minimum before use.

INSPECT

FOLLOW-ON MAINTENANCE:

Visually inspect repair for workmanship, no loose edges, no voids, cement fully cured.

END OF TASK

INITIAL SETUP**Applicable Configurations:**

All

Tools:

Portable Drill, Pneumatic, NSN 5130-00-293-1978
Abrasive Arbor, 1/4 Drive, 1 Inch Diameter, 1 Inch
Long, Dunmore Model R421003 or Equivalent

Materials:

Cloths (E120)
Methyl-Ethyl-Ketone (E244)
Scotch-Brite (E2)
Repair Cement — 2 Part Set (E63.2)
Wooden Tongue Depressor (E424)
Repair Fabric (E170.1)
Gloves (E184.1 and E186)

Personnel Required:

Aircraft Structural Repairer
Inspector

References:

None

Equipment Condition:

As Required

General Safety Instructions:**WARNING**

Methyl-ethyl-ketone (E244) and repair cement (E63.2) and its components are flammable and toxic. They can irritate skin and cause burns. Use only with adequate ventilation, away from heat or open flame. Avoid contact with skin, eyes or clothing. In case of contact, immediately flush skin or eyes with water for at least **15 minutes**. Get medical attention for eyes.

1. Repair hole damage, cuts, tears, and snags that penetrate outer coating and one or more exterior plies.
 - a. Trim away loose, damaged or blistered outer coating edges.
 - a.1. Clean damaged area using a clean cloth dampened with MEK (E244). Wear gloves (E184.1).

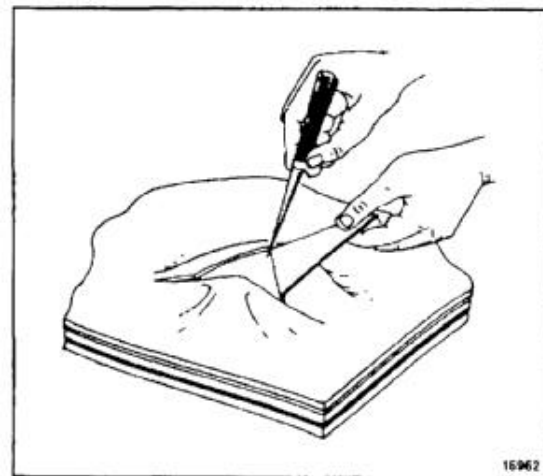

- b. Buff surface around damage **2-1/4 inches** larger in all directions than damaged area (1). Use portable drill (2), abrasive arbor, and/or Scotch-brite (E2). Buff only to remove gloss without excessively reducing outer coating thickness.
- c. Clean buffed area. Use clean cloths (E120) dampened with MEK (E244). Wear gloves (E184.1).

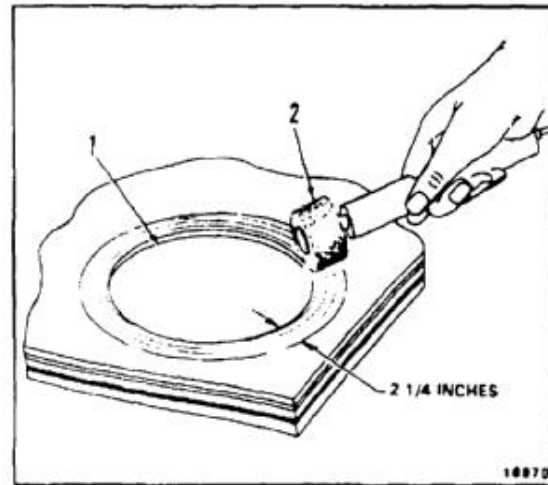

- d. Cut fabric reinforcing patch (3) from nylon fabric (E170.1) large enough to overlap damaged area (1) **2 inches** in all directions.

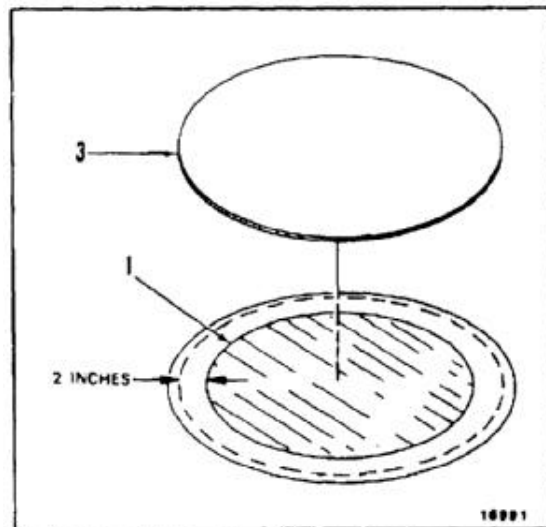

- e. Prepare repair cement (E63.2) by blending the two ingredients of part 2 (E63.5) together first and then transfer the entire contents of part 2 into the can of part 1 (E63.4). Wear gloves (E186).



Unmixed cement will not cure.

- f. Stir cement mixture with tongue depressor (E424) for approximately **5 minutes**. Make certain components are completely blended together.
- g. Carefully apply a uniform coat of repair cement (4) to no more than **1/4 inch** of O.D. of buffed area (5). Use a brush. Smooth surface with gloved fingers wet with MEK (E244) and remove any excess cement from unbuffed area with a clean cloth (E120) and MEK (E244). Wear gloves (E184.1).
- h. Wet fabric reinforcement patch (3) with MEK (E244). Shake out excess MEK.

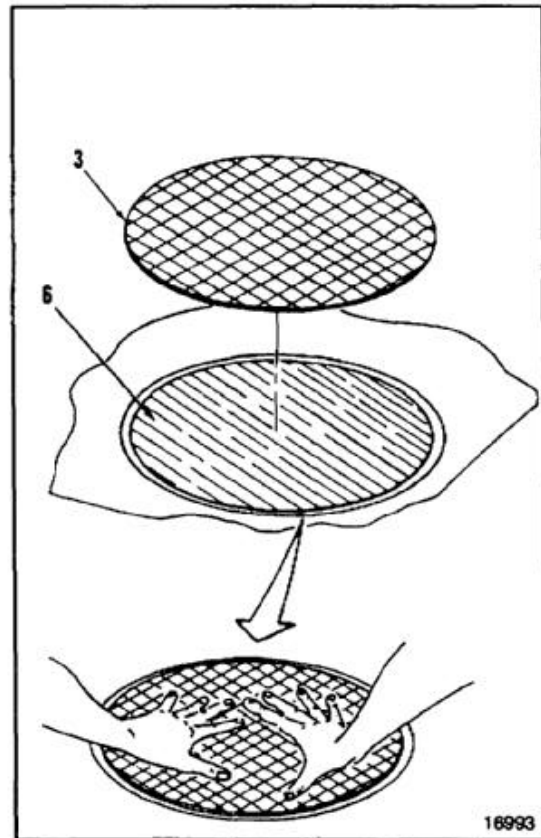

- i. Center wet patch (3) over defect area and press into wet cement (6) with gloved fingers to make sure patch is free of air bubbles and loose edges.

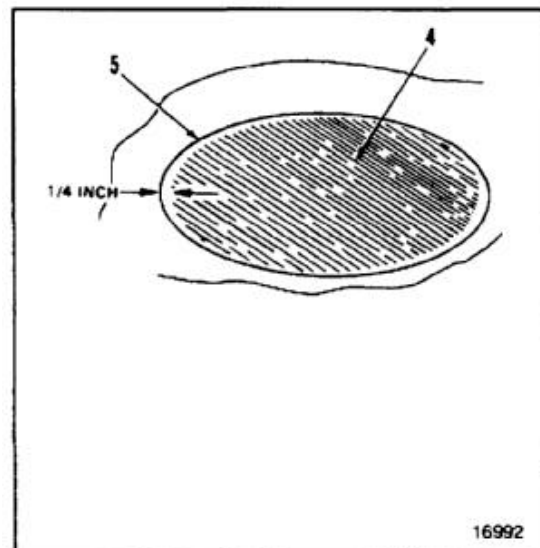

- j. Carefully apply a uniform coat of repair cement (E63.2) over patched area (4) to no more than **1/8 inch** buffed area edge. Use a brush. Smooth surface with gloved fingers wet with MEK (E244) and remove any excess cement from unbuffed area with a clean cloth (E120) and MEK (E244). Wear gloves (E184.1).
- k. Allow finished repair to set for **1 hour** before moving fuel cell.
- l. Allow finished repair to air cure for **24 hours** before use.

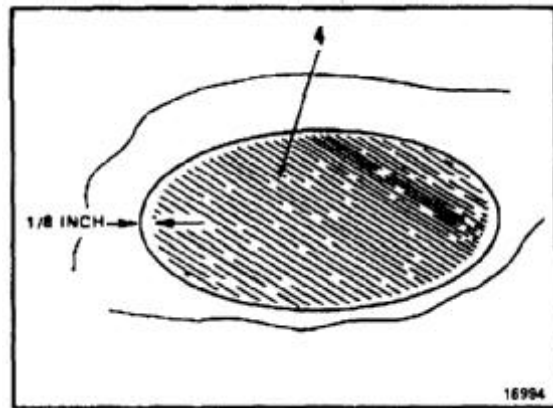
**INSPECT****FOLLOW-ON MAINTENANCE:**

Visually inspect repair for workmanship, no loose edges, no voids, cement fully cured.

Tasks 10-13 and 10-14 deleted.

END OF TASK

INITIAL SETUP

Applicable Configurations:

All

Tools:

Portable Drill, Pneumatic, NSN 5130-00-293-1978
Abrasive Arbor, 1/4 Drive, 1 Inch Diameter, 1 Inch
Long, Dunmore Model R421003 or Equivalent

Materials:

Cloth (E120)
Methyl-Ethyl-Ketone (E244)
Barrier Cement (E63.3)
Repair Cement — 2 Part Set (E63.2)
Gloves (E184.1 and E186)
Wooden Tongue Depressor (E424)
Scotch-Brite (E2)

Personnel Required:

Aircraft Structural Repairer
Inspector

References:

None

Equipment Condition:

As Required

General Safety Instructions:**WARNING**

Methyl-ethyl-ketone (E244) and barrier cement (E63.3), repair cement (E63.2) and its components are flammable and toxic. They can irritate skin and cause burns. Use only with adequate ventilation, away from heat or open flame. Avoid contact with skin, eyes, or clothing. In case of contact, immediately flush skin edges. or eyes with water for at least **15 minutes**. Get medical attention for eyes.

1. Repair blisters, cuts, tears, snags and abrasions that damage but do not penetrate the inner reinforcement plies (No Fabric Damage) as follows.
 - a. Clean damaged area using a clean cloth dampened with MEK (E244). Wear gloves (E184.1).
 - a.1. Trim away loose, damaged or blistered edges.
 - b. Buff surface around damage (1) **1-3/4 inches** larger in all directions than damaged area. Use portable drill (2), abrasive arbor, and/or scotch-brite (E-2). Buff only to remove gloss without excessively reducing inner layer thickness.
 - c. Clean buffed area. Use a clean cloth (E120) dampened with MEK (E244). Wear gloves (E184.1).
 - d. Prepare repair cement (E63.2) by blending the two ingredients of part 2 (E63.5) together first and then transfer the entire contents of part 2 into the can of part 1 (E63.4). Wear gloves (E186).

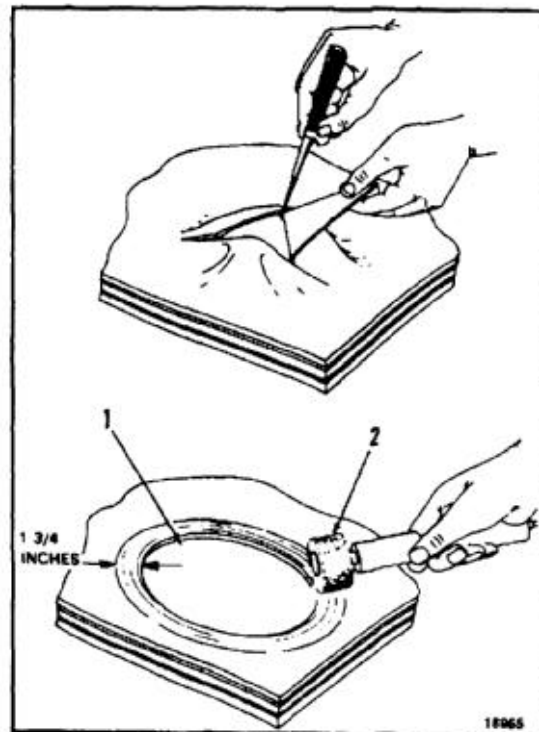

CAUTION

Unmixed cement will not cure.

- e. Stir cement mixture with tongue depressor (E424) for approximately **5 minutes**. Make certain components are completely blended together.
- f. Apply a light coat of cement mixture (3) over buffed repair area to no more than **1/4 inch** of O.D. of buffed area (4). Use a brush. Smooth surface with gloved fingers wet with MEK (E244) and remove any excess cement from unbuffed area. Use clean cloth (E120) dampened with MEK (E244). Wear gloves (E184.1). Allow to air cure for approximately **30 minutes**.

CAUTION

Barrier cement (E63.3) is soluble in methyl-ethyl-ketone (E244). Do not apply MEK to repair area after applying barrier cement.

CAUTION

Do not shake barrier cement (E63.3). Stir with a wooden tongue depressor (E424).

CAUTION

Keep lid on can of barrier cement (E63.3) when not in use to prevent evaporation and thickening.

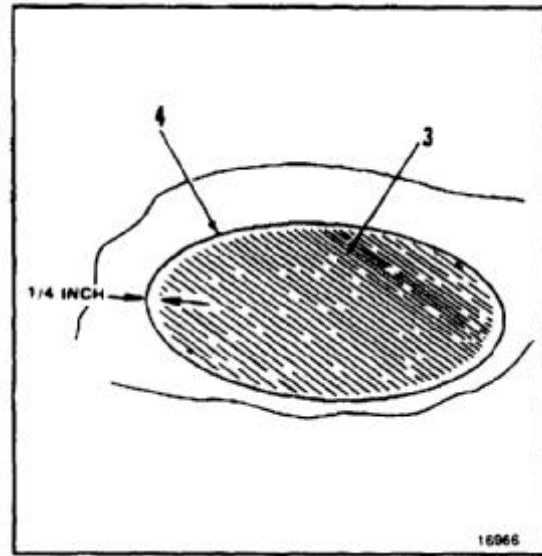

- g. Apply a uniform coat of barrier cement (E63.3) (4) over previous coat of repair cement (2) to within no more than **1/4 inch** of repair area of O.D. Use a brush (5). Remove any excess cement from unbuffered area. Use clean cloth (E120) dampened with MEK (E244). Wear gloves (E184.1). Allow barrier to dry to touch.
- h. Apply a second coat of barrier cement (E63.3) (6) over first barrier coat (4) at **90°** to the application of first coat. Use a brush. Allow second coat to air dry for approximately **30 minutes**.

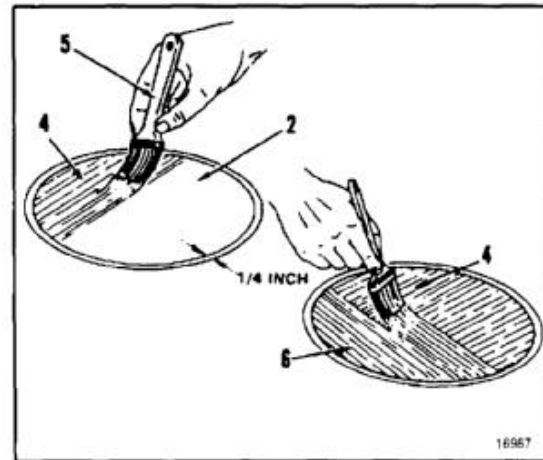

- i. Prepare repair cement (E63.2) as in steps d and e.
- j. Carefully apply a thin uniform coat of cement mixture (7) over previous coats of barrier cement to within no more than **1/8 inch** of O.D. of buffed edge area. Use a brush. Smooth surface with MEK (E244) and remove any excess cement from unbuffered area. Use clean cloth (E120) dampened with MEK (E244). Wear gloves (E184.1).



Do not flex fuel cell in repair area.

- k. Allow finished repair to set for **1 hour** before moving fuel cell.
- l. Allow finished repair to air cure for **24 hours** at room temperature of **70°F (33°C)** minimum before use.

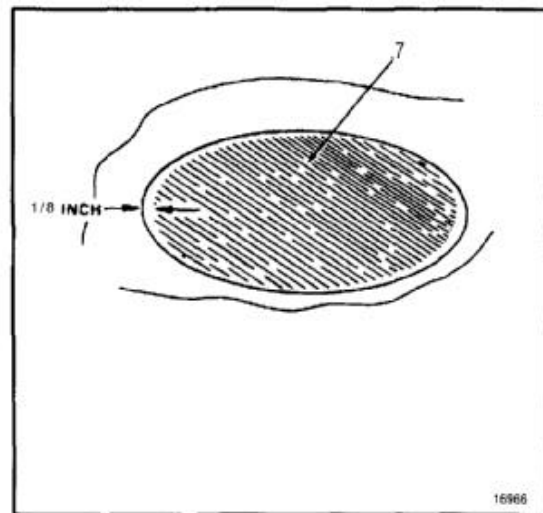

INSPECT

FOLLOW-ON MAINTENANCE:

Visually inspect repair for workmanship, no loose edges, no voids, cement fully cured.

END OF TASK

INITIAL SETUP

Applicable Configurations:

All

Tools:

Portable Drill, Pneumatic, NSN 5130-00-293-1978
Abrasive Arbor, 1/4 Drive, 1 Inch Diameter, 1 Inch
Long, Dunmore Model R421003 or Equivalent

Materials:

Cloths (E120)
Methyl-Ethyl-Ketone (E244)
Repair Fabric (E170.2)
Repair Cement — 2 Part Set (E63.2)
Wooden Tongue Depressor (E424)
Scotch-Brite (E2)
Gloves (E184.1 and E186)
Barrier Cement (E63.3)

Personnel Required:

Aircraft Structural Repairer
Inspector

1. Repair hole damage, cuts, tears, and snags that penetrate one or more interior plies (fabric damage) as follows:
 - a. Trim away loose, damaged or blistered interior edges.
 - a.1. Clean damaged area using a clean cloth dampened with MEK (E244). Wear gloves (E184.1).

References:

None

Equipment Condition:

As Required

General Safety Instructions:**WARNING**

Methyl-ethyl-ketone (E244), barrier cement (E63.3) and repair cement (E63.2) and its components are flammable and toxic. They can irritate skin and cause burns. Use only with adequate ventilation, away from heat or open flame. Avoid contact with skin, eyes or clothing. In case of contact, immediately flush skin or eyes with water for at least **15 minutes**. Get medical attention for eyes.

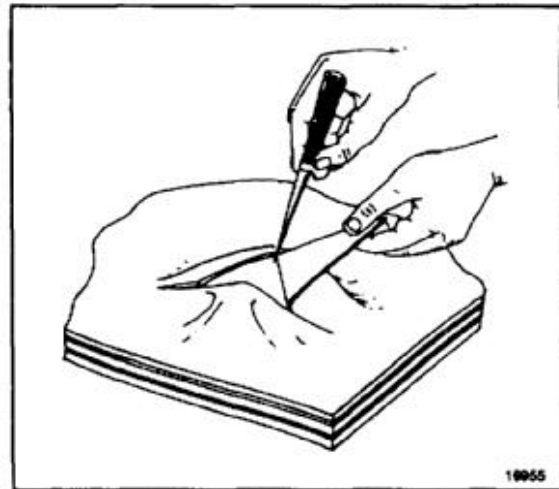

10-15.1 REPAIR FUEL CELL INTERIOR PLIES (Continued)

10-15.1

- b. Buff surface around damage (1) **2-1/4 inches** larger in all directions than damaged area. Use portable drill; abrasive arbor (2), and/or scotch-brite (E2). Buff only to remove gloss without excessively reducing outer coating thickness.
- c. Clean buffed area. Use clean cloths (E120) dampened with MEK (E244). Wear gloves (E184.1).

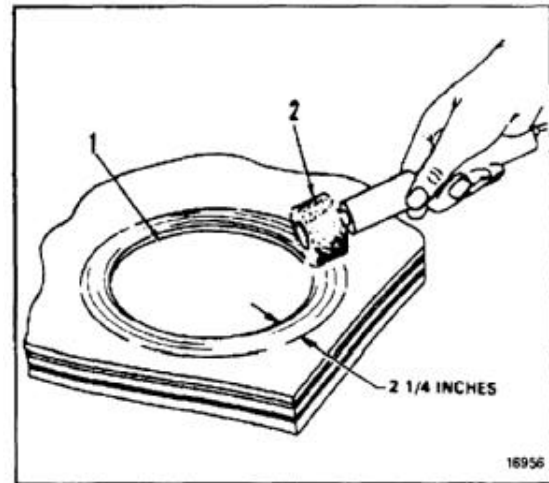

- d. Cut fabric reinforcing patch (3) from nylon fabric (E170.1) large enough to overlap damaged area (1) **2 inches** in all directions.

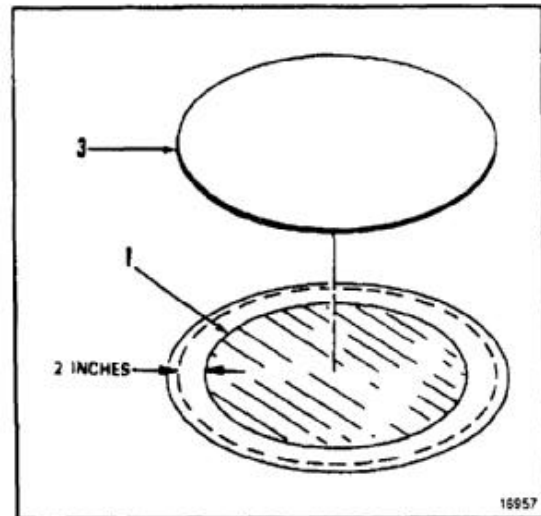

- e. Prepare repair cement (E63.2) by blending the two ingredients of part two (E63.5) together first and then transfer the entire contents of part two into the can of part one (E63.4). Wear gloves (E186).

CAUTION

Unmixed cement will not cure.

- f. Stir cement mixture with tongue depressor (E424) for approximately **5 minutes**. Make certain components are completely blended together.
- g. Fill cavity of damaged area (1) level with inner liner with cement mixture (4) to make a smooth continuous surface to apply barrier over. Smooth surface with gloved fingers wet with MEK (E244). Remove any excess cement from unbuffered area using a clean cloth dampened with MEK (E244). Apply cement mixture to no more than **1/4 inch** of O.D. of buffered area (5).
- h. Allow cement to air cure for approximately **30 minutes**.

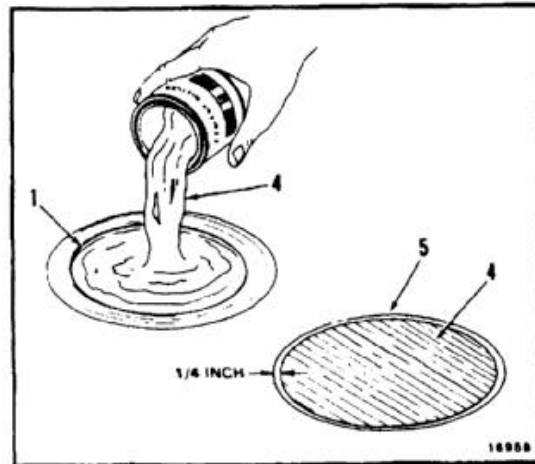

CAUTION

Barrier cement (E63.3) is soluble in methyl-ethyl-ketone (E244). Do not apply MEK to repair area after applying barrier cement.

CAUTION

Do not shake barrier cement (E63.3). Stir with a wooden tongue depressor (E424).

CAUTION

Keep lid on can of barrier cement (E63.3) when not in use to prevent evaporation and thickening.

- i. Carefully apply a uniform coat of barrier cement (E63.3) (5) over previous coat of repair cement mixture (6). Use a brush (7). Remove any excess cement from unbuffered area. Use a clean cloth (E120) and MEK (E244). Wear gloves (E184.1). Allow barrier to dry to touch.
- j. Apply a second coat of barrier cement (8) over first coat at **90°** to the application of the first coat. Use a brush. Allow second coat to air dry for **30 minutes**.
- k. Prepare repair cement (E63.3). (See steps e and f.)
- l. Carefully apply a uniform coat to repair cement (9) over previous coats of barrier cement. Smooth surface with MEK (E244) and remove any excess cement from unbuffered area with a clean cloth (E120) and MEK (E244). Wear gloves (E184.1).
- m. Wet fabric reinforcement patch (2) with MEK (E244). Shake out excess MEK (E244).
- n. Center wet patch over defect area and press into wet cement (9) with fingers to make certain patch is free of air bubbles and loose edges.
- o. Allow cement and fabric patch to air cure approximately **30 minutes**.

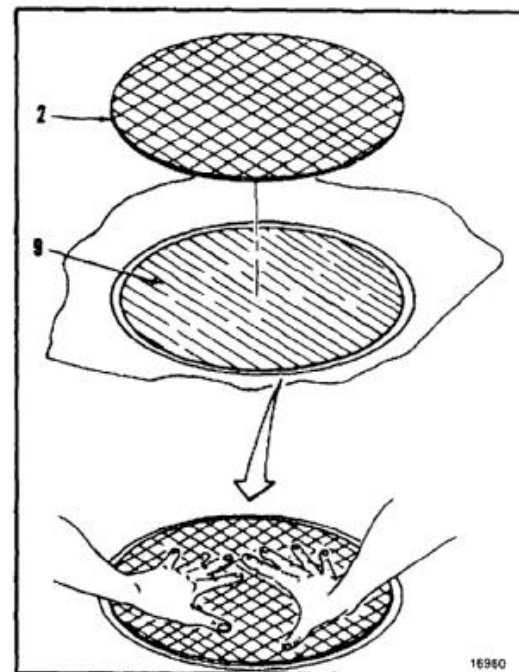
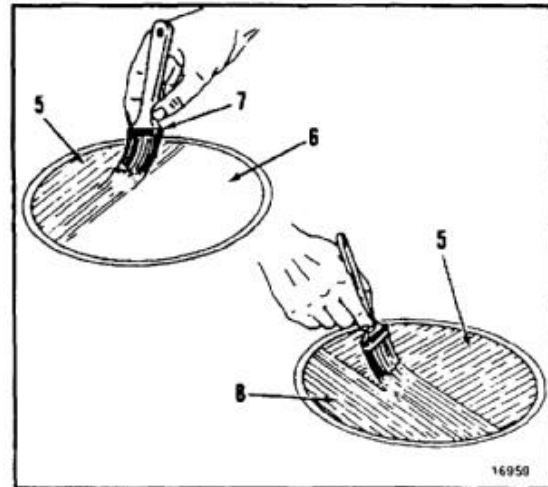

- p. Carefully apply a uniform coat of repair cement (10) over patched area to within no more than **1/8 inch** of O.D. of buffed edge. Smooth surface with gloved fingers wet with MEK (E244). Use a brush. Remove any excess cement with cloths (E120) dampened with MEK (E244). Wear gloves (E184.1).



Do not flex fuel cell in repair area.

- q. Allow finished repair to set for **1 hour** before moving fuel cell.
- r. Allow finished repair to air cure for **24 hours** before use.

INSPECT

FOLLOW-ON MAINTENANCE:

Visually inspect repair for workmanship, no loose edges, no voids, cement fully cured.

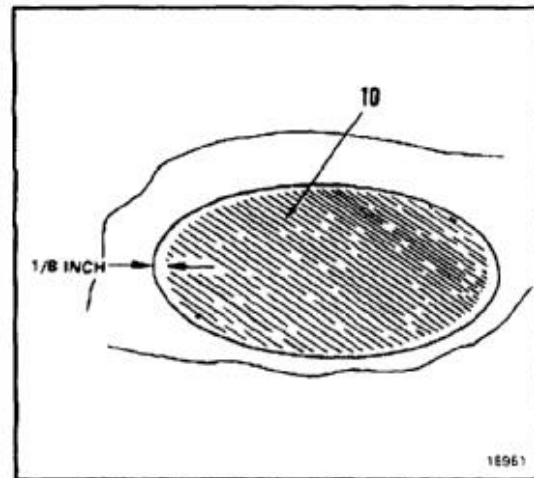

END OF TASK

INITIAL SETUP

Applicable Configurations:

All

Tools:

Aircraft Mechanic's Tool Kit, NSN 5180-00-323-4692
 Overhead Suspension for Fuel Cell (Appendix E-16)
 Tee Fitting
 Manometer
 Source of Low Pressure Dry Air
 Trip Balance
 Graduate (2000 cc)
 Open Container, 2 Gallons

Materials:

Ammonium Hydroxide (E73)
 Cloths (E120)
 Phenolphthalein Crystals (E276)
 Ethyl Alcohol (E167)
 Gloves (E186)

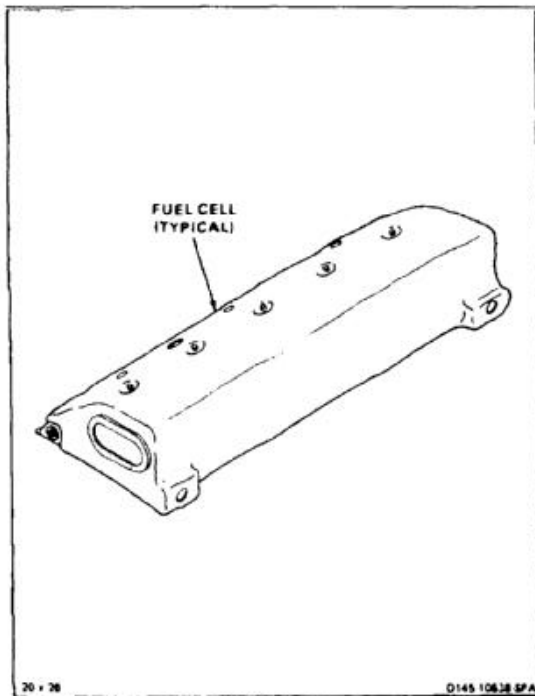
**Personnel Required:**

Medium Helicopter Repairer
 Inspector

References:

Task 10-2
 Task 10-11
 Task 10-12
 Task 10-15

Equipment Condition:

Off Helicopter Task

General Safety Instructions:**WARNING**

Test pressure within the fuel coil shall not exceed **1.5 psi**. Damage to the cell could result in personal injury or death.

WARNING

Ethyl alcohol is flammable. Use only with adequate ventilation, away from heat or open flame. In case of contact, immediately flush skin or eyes with water for at least **15 minutes**. Get medical attention for eyes.

WARNING

Ammonium hydroxide is extremely toxic. It can irritate skin and cause burns. Avoid inhaling. Use only with adequate ventilation. Avoid contact with skin, eyes, or clothing. In case of contact, immediately flush skin or eyes with water for at least **15 minutes**. Get medical attention for eyes.

NOTE

Procedure is same for testing any fuel cell. Main cell is shown here.

1. Install fuel cell (1) in cage, jig or overhead suspension system (2).
2. Install plugs or sealed fittings in all tank openings (3). Leave main access door (4) and one tank opening (5) unsealed.
3. Install tee assembly (6) in tank opening (5).
4. Connect hose (7) from air supply to one leg of tee (6).
5. Connect manometer (8) to other leg of tee (6).
6. Pour **114 cc** of ammonium hydroxide (E73) on cloth (E120). Wear gloves (E186).
7. Insert wet cloth into fuel cell (1) through main access (4).
8. Install cover plate (9) on main access hole (4). Install screws (10) and washers (11).
9. Prepare solution of **40 grams** of phenolphthalein crystals (E276) and **2 quarts** of ethyl alcohol (E167). Stir solution thoroughly.
10. Add **2 quarts** of water to solution and stir.
11. Inflate cell (1) with dry air to **1 to 1.5 psi** maximum.
12. Dip cloth (E120) into solution and wring out cloth thoroughly.
13. Spread cloth on exterior surface of cell (1) and press cloth to ensure contact with surface. Wait at least **30 seconds**.

NOTE

Wear gloves through rest of task.

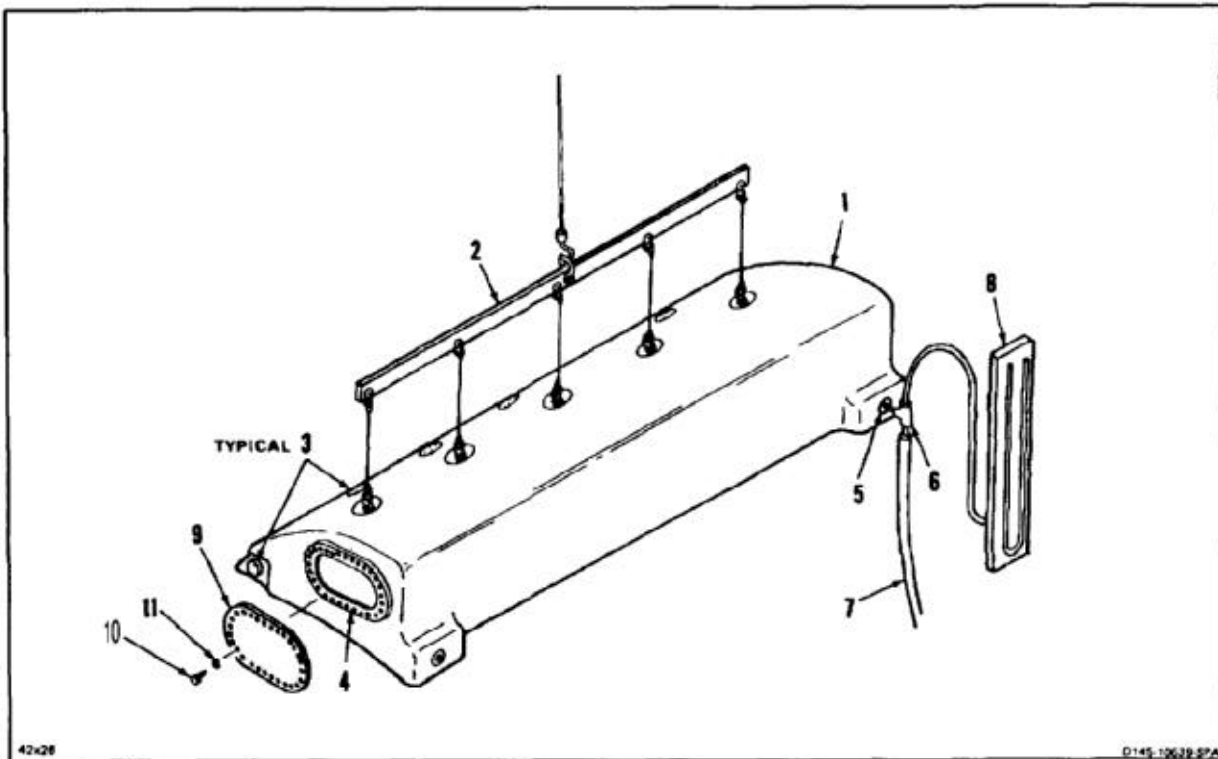

10-16 TESTING REPAIRED CELL — CHEMICAL (Continued)**10-16**

14. Remove cloth and inspect tank for red spots indicating leak.
15. Note location of leaks.
16. Repeat steps 12, 13, and 14 until all exterior surfaces of cell (1) have been covered.
17. Repair fuel cell as necessary (Tasks 10-11, 10-12, and 10-15).
18. Repeat steps 11 thru 17 as necessary.
19. Disconnect air supply.
20. Remove access door (9) and cloth from interior of cell (1).
21. Remove manometer (8), tee (6) and all plugs or sealed fittings from tank openings (3).
22. Purge fuel cell (1) (Task 10-2).
23. Allow cell (1) to air dry.

INSPECT**FOLLOW-ON MAINTENANCE:**

As Required

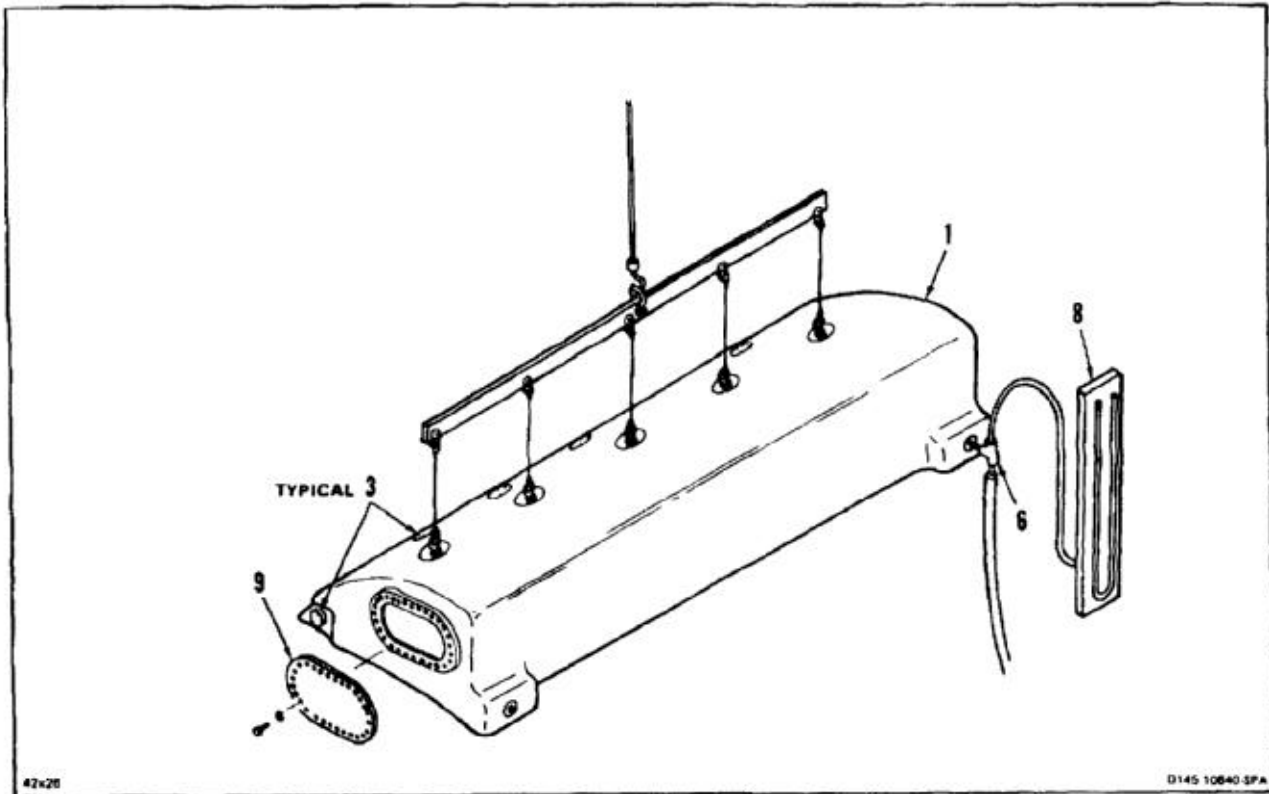

END OF TASK

INITIAL SETUP

Applicable Configurations:

All

Tools:

Aircraft Mechanic's Tool Kit, NSN 5180-00-323-4692
 Overhead Suspension for Fuel Cell (APP E-16)
 Tee Fitting
 Manometer
 Source of Low Pressure Dry Air
 Open Container, 5 Gallon

Materials:

Brush (E85)
 Soap (E353)

Personnel Required:

Medium Helicopter Repairer
 Inspector

References:

Task 10-2
 Task 10-3
 Task 10-11
 Task 10-12
 Task 10-15

Equipment Condition:

Off Helicopter Task

General Safety Instructions:**WARNING**

Test pressure within the fuel cell shall not exceed **1.5 psi**. Damage to the cell could result in personal injury or death.

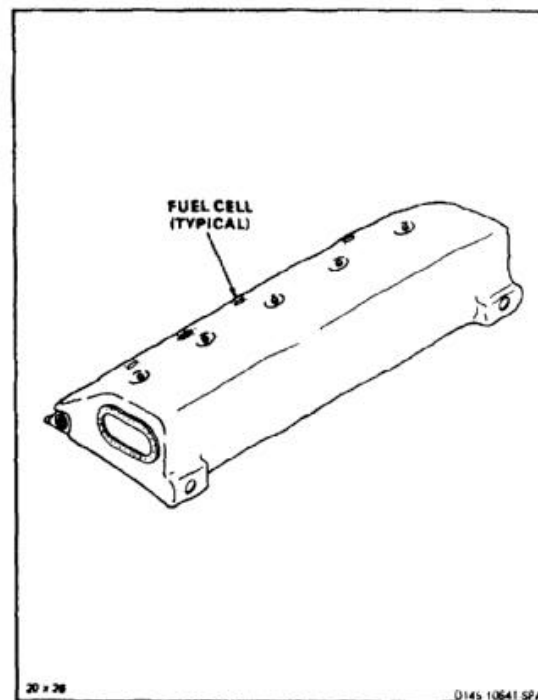

NOTE

Procedure is same for testing any fuel cell. Main cell is shown here.

1. Install cell (1) in cage, jig or overhead suspension system (2).
2. Install plugs or sealed fittings in all tank openings (3). Leave one tank opening (4) unsealed.
3. Install tee assembly (5) in tank opening (4).
4. Connect hose (6) from air supply to one leg of tee (5).
5. Connect manometer (7) to other leg of tee (5).
6. Inflate cell (1) with dry air to **1 to 1.5 psi** maximum.
7. Prepare suds mixture of soap and water. Use soap (E353).
8. Apply suds mixture to external surfaces of cell (1). Use brush (E85).
9. Check surface of cell (1) for bubbling of suds.
10. Note location of air leaks.
11. Remove all soap residue from surface of cell (1). Use water.
12. Repair fuel cell (1) as necessary (Tasks 10-11, 10-12, and 10-15).
13. Repeat steps 6 thru 12 as necessary.

INSPECT

14. Disconnect air supply hose (6).
15. Remove manometer (7), tee (5), and all plugs or sealed fittings from tank openings (3).

FOLLOW-ON MAINTENANCE:

As Required

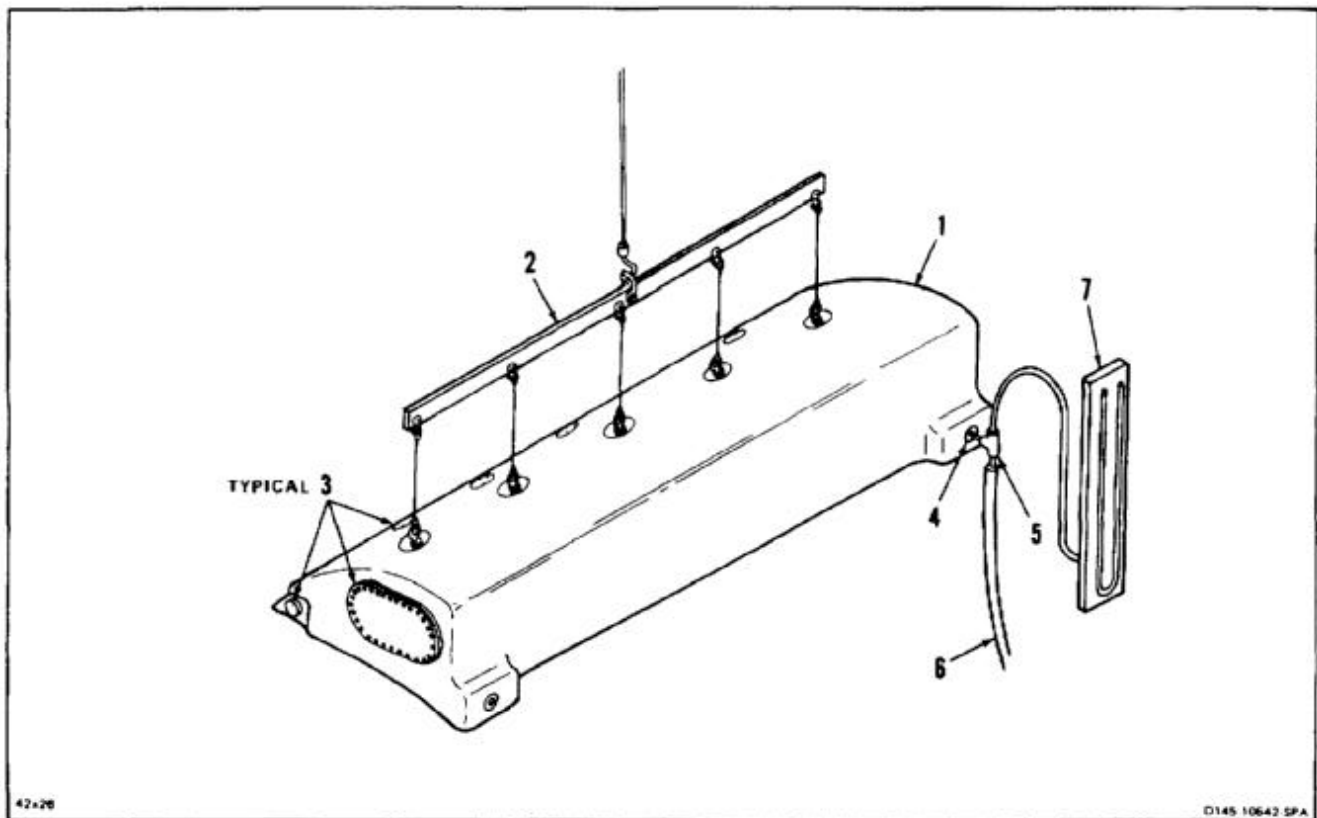

END OF TASK

INITIAL SETUP

Applicable Configurations:

All

Tools:

As Required

Materials:

Fiberboard Shipping Box (E82)

Personnel Required:

Medium Helicopter Repairer (2)

References:

MIL-P-25621

Equipment Condition:

Off Helicopter Task

1. Cushion fittings (1) on cell (2).
2. Block cell (2) to prevent collapsing. Use suitable framework (MIL-P-25621). Cover framework with padding material.
3. Place cell (2) into fiberboard shipping box (E82).
4. Use padding material to cushion cell (1) and prevent movement inside box.



Do not use nails to seal shipping box.
Damage to cell could occur.

5. Seal shipping box (MIL-P-25621).

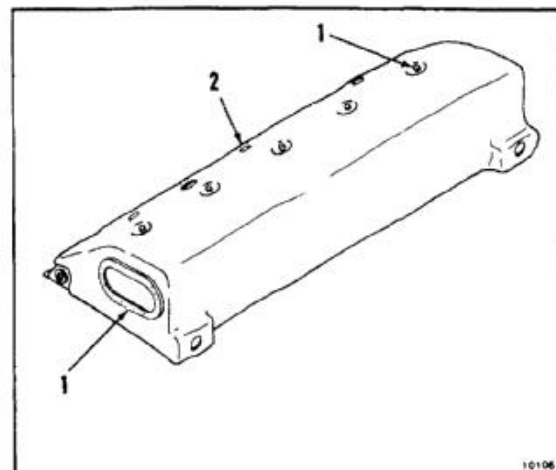
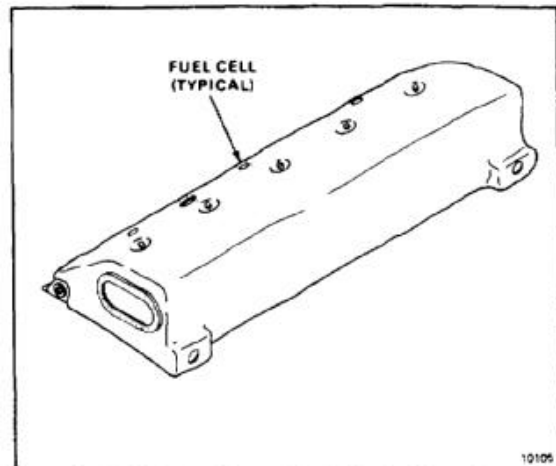
**FOLLOW-ON MAINTENANCE:**

None

END OF TASK

10-70

INITIAL SETUP

Tools:

Aircraft Mechanic's Tool Kit, NSN 5180-00-323-4692
Container, 5 Gallon

Materials:

Cloths (E135)
Lubricating Oil (E251)
Barrier Material (E80)
Tape (E388)

Personnel Required:

Medium Helicopter Repairer
Inspector

References:

TM 1-1500-204-23

Equipment Conditions:

As Required

General Safety Instructions:**WARNING**

All regulations and instructions for handling fuels shall be strictly observed.



Use only clean unused oil. (Refer to TM 1-1500-204-23.)

NOTE

After approximately **10 days**, tanks drained of fuel will dry out. This results in checked and cracked inner walls. Access to inner wall of cell will vary, dependant upon level of disassembly of tank.

1. Gain access to inside of tank cell.
2. Apply light coat of lubricating oil (E251) to inner wall of cell. Apply oil by spraying, fogging, sloshing or painting.
3. Drain excess oil into container.

INSPECT

4. Cover access hole with removed component or barrier material (E80) and tape (E388).

FOLLOW-ON MAINTENANCE:

None

END OF TASK

INITIAL SETUP

Applicable Configurations:

All

Tools:

Aircraft Mechanic's Tool Kit, NSN 5180-00-323-4692

Materials:

Barrier Material (E80)
Tape (E383)
Gloves (E184.1)
Epoxy Primer (E292.1)

Personnel Required:

Medium Helicopter Repairer
Inspector

References:

Task 2-6
Task 2-337
Task 10-8
Task 10-10
Task 10-11
Task 10-12
Task 10-15
Task 10-18

Equipment Condition:

Off Helicopter Task

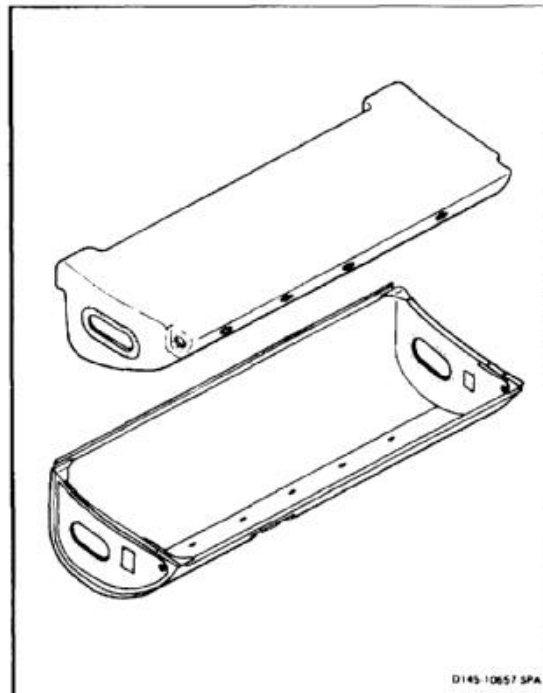

NOTE

Inspection of all fuel cells and tanks is same.

FUEL CELL

1. Inspect inside surface (1) and outside surface (2) of cell, for cuts and scuffed areas.
2. Classify damage (Task 10-10).
3. Repair damage (Tasks 10-11, 10-12, and 10-15).
4. Inspect fitting seal surfaces (3) for nicks, scratches and foreign materials.
5. Repair damage (Task 10-14).
6. Inspect inner lining of cell for surface mold. Pay particular attention to isolated areas.
7. Clean any affected areas (Task 10-8).

FUEL POD

8. Inspect interior of pod (4) for burrs, bare rivets or any condition that could cause chafing of fuel cell (2).

WARNING

Epoxy primer (E292.1) is flammable and toxic. It can irritate skin and cause burns. Avoid inhaling. Use only with adequate ventilation. Avoid contact with skin, eyes, or clothing. Keep away from heat, sparks, or open flame. In case of contact, immediately flush skin or eyes with water for at least **15 minutes**. Get medical attention for eyes.

9. If any burrs are discovered, burnish area until surface is smooth, and finish with two coats of epoxy primer (E292.1) (Task 2-6). Wear gloves (E184.1).
10. If a bare rivet head or a condition that could cause chafing is found, apply anti-chafing tape (E383) to those areas (Task 2-337).
11. Inspect pod fitting seal surfaces (5) for nicks, scratches, and foreign materials.

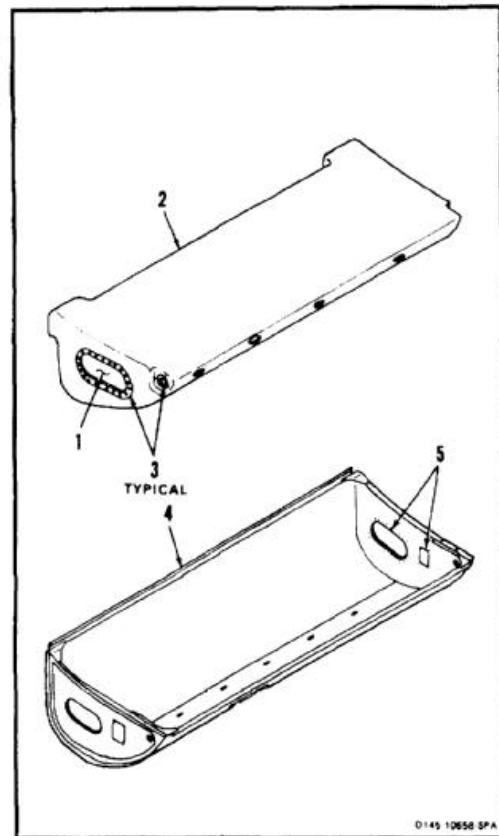

12. If cell will not be refueled within **10 days**, preserve cell (Task 10-18).
13. If tank will not be assembled, cover all openings. Use barrier material (E80) and tape (E388).

FOLLOW-ON MAINTENANCE:

Install main fuel tank cell (Task 10-20).
Install forward fuel tank cell (Task 10-25).
Install aft fuel tank cell (Task 10-30).

END OF TASK

10-19.1 PREPARATION TO REPLACE MAIN FUEL PODS

10-19.1

INITIAL SETUP**Applicable Configurations:**

All

Tools:

Drill Size O
 Drill Size F
 Aircraft Mechanic's Tool Kit, NSN 5180-00-323-4692

Materials:

Lockwire (E232)
 Epoxy Primer (E292.1)
 Gloves (E184.1)

Personnel Required:

Structural Repairer (2)
 Inspector

References:

TM 55-1520-240-23P
 Task 10-20
 Task 10-21

Equipment Condition:

Right or Left Main Fuel Tanks Removed (Task 10-28)

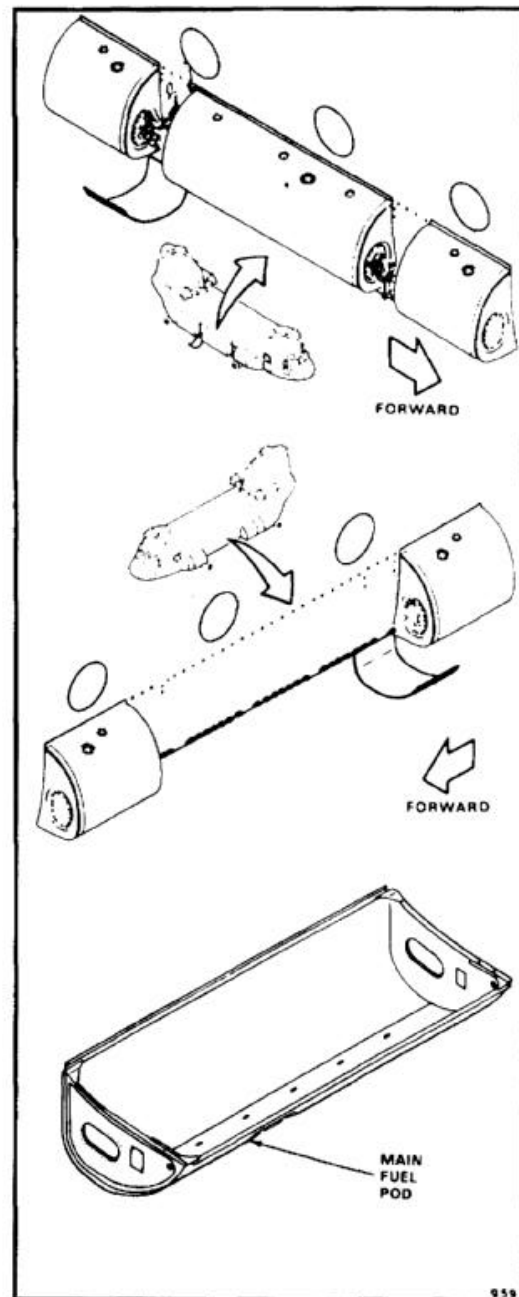

NOTE

Procedure is same to prepare to replace left or right main fuel pod. Left fuel pod is shown here.

1. With aid from helper, position pod (1) on padded support (2) at side of aircraft. Align fuselage hinge half (3) with tank hinge half (4).
2. Install four hinge pins (5, 6, 7, and 8) in hinge (3 and 4).
3. Install lockwire at five places (9) to secure hinge pins (5, 6, 7, and 8). Use lockwire (E232).

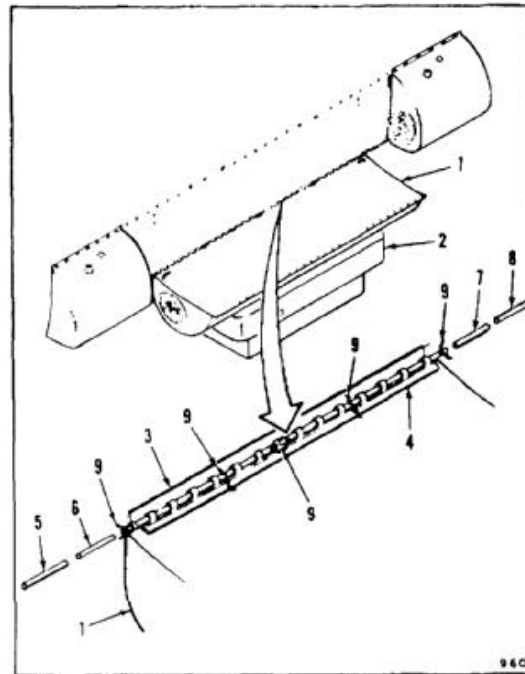

10-19.1 PREPARATION TO REPLACE MAIN FUEL PODS (Continued)

10-19.1

4. Raise pod (1) and position against side of aircraft.
5. Working from inside aircraft mark 37 bolt holes (10) along top of pod (1), and 4 bolt holes (11) on side of pod. Use holes in fuselage (12) as guide.
6. Lower pod (1) on support (2).
7. Drill 37 holes (10) in top support angle (13). Deburr holes. Use drill size F.
8. Drill 4 holes (11) in side support angle (14). Deburr holes. Use drill size O.

INSPECT**WARNING**

Epoxy primer (E292.1) is flammable and toxic. It can irritate skin and cause burns. Avoid inhaling. Use only with adequate ventilation. Avoid contact with skin, eyes, or clothing. Keep away from heat, sparks, or open flame. In case of contact, immediately flush skin or eyes with water for at least **15 minutes**. Get medical attention for eyes.

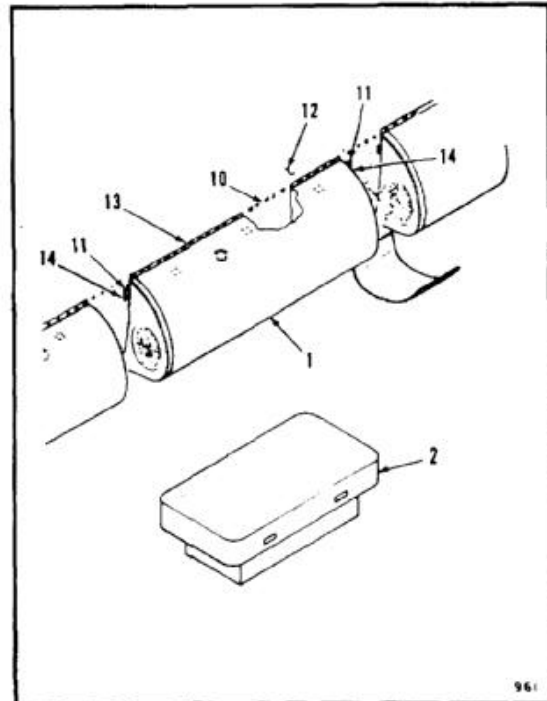

9. Apply epoxy primer (E292.1) to drilled holes (10 and 11). Wear gloves (E184.1).
10. Perform Task 10-20.
11. Perform Task 10-21.

FOLLOW-ON MAINTENANCE:

Test main tank after installation (Task 10-22).
 Perform vent system pressure test (Task 10-117) and flow test (Task 10-118) on affected tank.
 Perform test of pressure refueling system (Task 10-119) and fuel feed system (Task 10-120).
 Refuel all tanks (Task 1-51).
 Check for leaks (Task 10-4).
 Bleed fuel system (Task 10-121).
 Perform operational check of affected fuel system (TM 55-1520-240-T).
 Install forward landing gear access panel (Task 2-179 or 2-181).
 Close and secure aft intertank pod panel (Task 2-2).
 Install main fuel tank vent fairing (Task 10-64).

END OF TASK

INITIAL SETUP

Applicable Configurations:

All

Tools:

Aircraft Mechanic's Tool Kit, NSN 5180-00-323-4692
Torque Wrench, 700 to 1600 Inch-Pounds
Torque Wrench, 30 to 150 Inch-Pounds

Materials:

Petrolatum (E274)

Parts:

Packings
Gaskets

Personnel Required:

Medium Helicopter Repairer
Aircraft Electrician
Inspector

References:

TM 55-1520-240-23P
Task 10-40

General Safety Instructions:

Do not puncture or scratch lining of fuel cell. If lining is broken, fuel penetrates and activates self-sealing layers. Activated layers swell and trap fuel. Activated green spongy material also contaminates fuel system. This makes it necessary to replace fuel cell and flush fuel system.

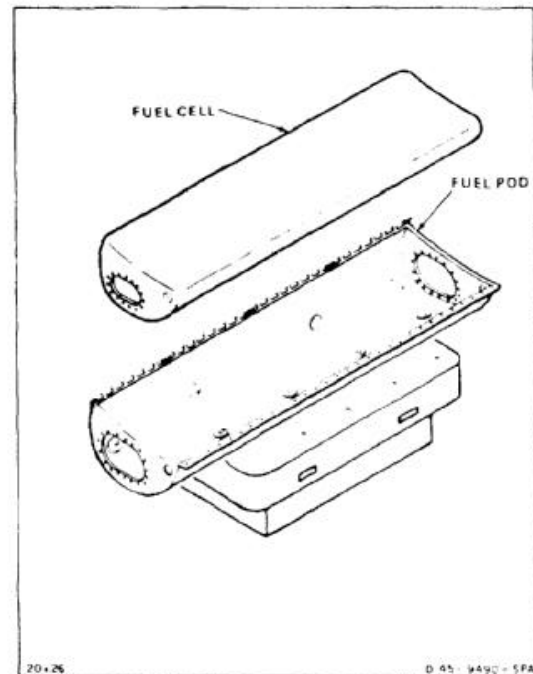

Fuel Cell Hardware Configuration**NOTE**

When installing main fuel cells, there are differences in hardware configuration as noted below.

414PS400-8 Goodyear/Loral	414PS400-10 Uniroyal/Amfuel
Aft Pump Bracket and Drain Flange to Cell	Aft Pump Bracket and Drain Flange to Cell
AN4C10A Bolt (4)	AN4C6A Bolt (4)
AN960PD416 Washer (4)	AN960PD4161 Washer (4)
BACB28Z4-038 Bushing (4) *	AN960PD416 Washer (4)
Fwd Pump	Fwd Pump
AN4C7A Bolt (4)	AN4C4A Bolt (4)
AN960PD416 Washer (4)	AN960PD416L Washer (4)
BAC28Z4-038 Bushing (4)	AN960PD416 Washer (4)

HIGH LEVEL SHUTOFF VALVE INSTALLATION

114P4332-9 Bracket (1)	114P4332-9 Bracket (1)
AN4C4A Bolt (4)	AN4C4A Bolt (4)
AN960PD416L Washer (7)	AN960PD416L Washer (7)
AN4C3A Bolt (3)	AN4C3A Bolt (3)
114P4332-10 Bracket (1)	114P4332-10 Bracket (1)
M85052/1-16 Clamp (1)	M85052/1-16 Clamp (1)
NAS43DD3-32 Spacer (1)	NAS43DD3-32 Spacer (1)
AN960PD416L Washer (1)	AN960PD416L Washer (1)
AN4C15A Bolt (1)	AN4C15A Bolt (1)

* POSITIONED BETWEEN
BRACKET AND CELL

NOTE

Procedure is same to install cell in No. 1 or No. 2 fuel tank pod. Installation of No. 1 (left) cell is shown here.

NOTE

Before installing main fuel tank check backboard for condition.

1. Make sure interior of fuel tank pod (1) is free of foreign material.
2. Position fuel cell (2) carefully in tank pod (1). Insert lower portion of cell in pod. Depress top portion of cell. Position it in and along top portion of tank pod.
3. Form cell (2) to fit contour of pod structure (1).
4. Install bolt (3) and washer (4). Do not tighten bolt at this time.
5. Install four bolts (5, 6, 7, and 8) and washers (4) in this order. Do not tighten bolts at this time.
6. Tighten five bolts (3, 5, 6, 7, and 8) in this order.
7. Coat two packings (9) with petrolatum (E274). Install packings carefully in annular groove of flange (10) at each end of tank. Make sure that packings are not disturbed during positioning of fuel cell (2) in pod (1).
8. Align holes (11) in pod (1) with holes (12) in cell (2). Install eight bolts (13) and washers (14). Torque bolts to **60 to 80 inch-pounds**.

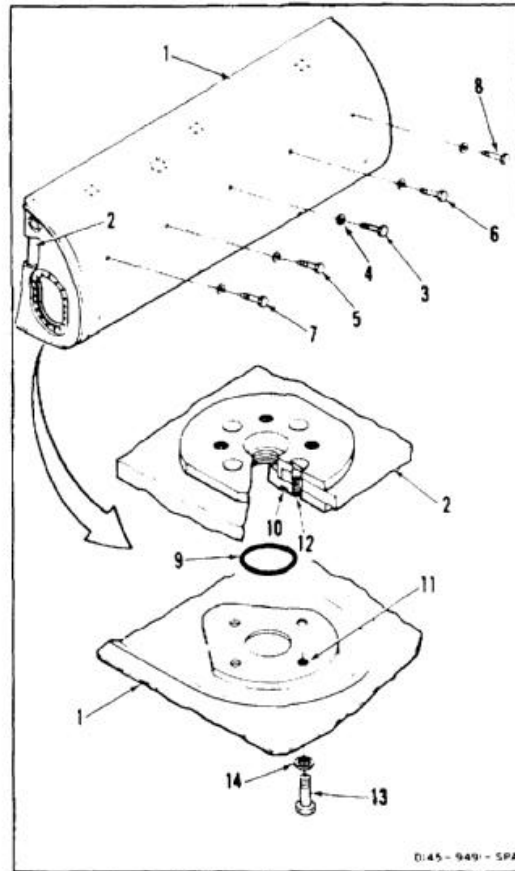

10-20 INSTALL MAIN FUEL TANK CELL (Continued)**10-20**

9. Coat two packings (15) with petrolatum (E274). Install packings carefully in annular groove of flange (16) at each end of cell (2). Make sure packings are not disturbed during positioning of fuel cell in pod (1).
10. Align holes (17) with holes (18). Install two screws (19) at each end of tank pod (1).
11. Coat two packings (20) with petrolatum (E274). Install packings carefully in annular groove of closure plate (21). Position closure plate at each end of tank pod (1).
12. Install four bolts (22) and washers (23). Torque bolts to **60 to 80 inch-pounds**.
13. Coat packing (24) with petrolatum (E274). Install packing carefully in annular groove of cell flange (25). Make sure packing is not disturbed during positioning of fuel cell (2) in pod (1).
14. Align hole (26) in cell (2) with hole (27) in pod (1). Install three screws (28).
15. Position gasket (29) and filler adapter assembly (30). Install four bolts (31) and washers (32). Torque bolts to **60 to 80 inch-pounds**.
16. Position gaskets (33) on three flanges (34) of fuel cell (2). Align holes (35) in fuel cell with holes (36) in tank pod (1). Install six screws (37).

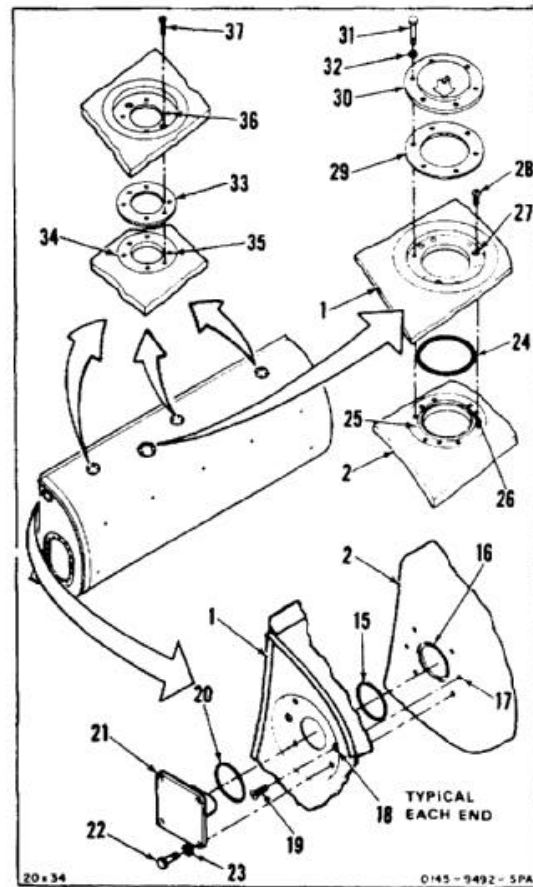

17. Lightly smear both sides of gaskets (38) with petrolatum (E274).
18. Position gaskets (38) between fuel pod (1) and fuel cell (2) at both ends of fuel pod.
19. Align fuel pod (1), gasket (38), and fuel cell (2). Install four screws (39) at each end of tank pod.

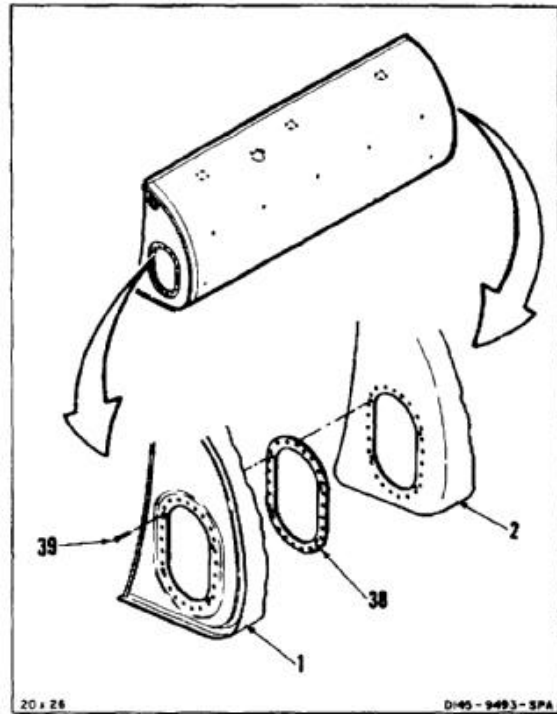

20. Install fuel tank drain valve (Task 10-40).

INSTALL TWO BOOST PUMP BRACKETS

NOTE

Four different types of main fuel cells are used on the helicopter. Each is interchangeable and may require four washers or bushings between pump bracket and cell.

Procedure is same to install forward and aft boost pump mounting bracket. Installation of forward mounting bracket is shown here.

21. For fuel tank 145P4057-1 position four washers (42) on cell flange (41). For fuel tank 414PS400-8 or 145P4057-2 position four bushings (43) on cell flange (41).
22. Position pump bracket (44).
23. On aft pump bracket (44) position flange assembly (45).
24. Install four bolts (46) and washers (47).

INSPECT

FOLLOW-ON MAINTENANCE:

- Install fuel level control valve and mounting bracket (Task 10-60).
- Install main fuel tank vent assembly (Task 10-44).
- Install main fuel tank lines and electrical wiring (Task 10-42).
- Install main fuel tank aft boost pump (Task 10-54).
- Install main fuel tank forward boost pump (Task 10-52).
- Install main fuel tank quantity transmitters (Task 8-82).
- Install main fuel tank (Task 10-21).

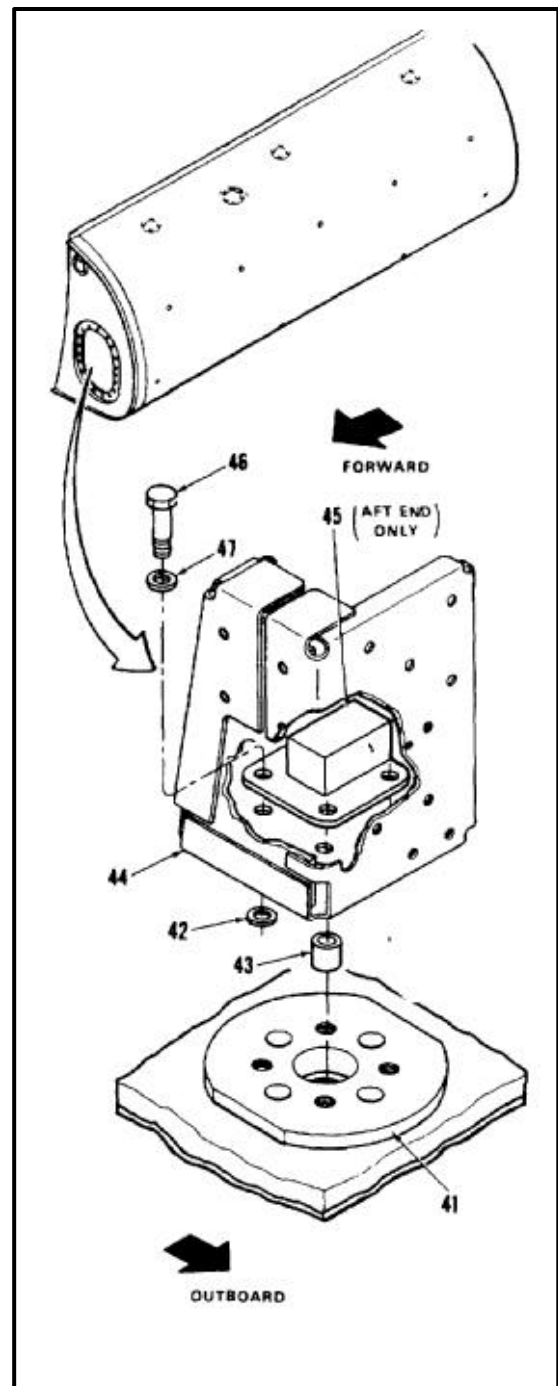

END OF TASK

INITIAL SETUP

Applicable Configurations:

All

Tools:

Aircraft Mechanic's Tool Kit, NSN 5180-00-323-4692
 Wrench, Open End, 1-1/2 Inch
 Wrench, Open End, 1-7/8 Inch

Materials:

Lockwire (E232)
 Tiedown Straps (E375)
 Parting Agent (E307)
 Dry Cleaning Solvent (E162)
 Gloves (E184.1)
 Sealant (E336)
 Cloths (E135)
 Tongue Depressor (E424)

Parts:

Gaskets

Personnel Required:

Medium Helicopter Repairer (3)
 Inspector

References:

TM 55-1520-240-23P

General Safety Instructions:**WARNING**

All regulations and instructions for handling fuels shall be strictly observed.

Dry cleaning solvent (E162) is flammable and toxic. It can irritate skin and cause burns. Use only in well-ventilated area, away from heat and open flame. In case of contact, immediately flush skin or eyes with water for at least **15 minutes**. Get medical attention for eyes.

WARNING

Parting agent (E307) can form toxic vapors if exposed to flame. Use in well-ventilated area, away from open flame. In case of contact, immediately flush skin or eyes with water for at least **15 minutes**. Get medical attention for eyes.

Sealant (E336) can irritate skin and cause burns. Avoid contact with skin, eyes, and clothing. In case of contact, immediately flush skin or eyes with water for at least **15 minutes**. Get medical attention for eyes.

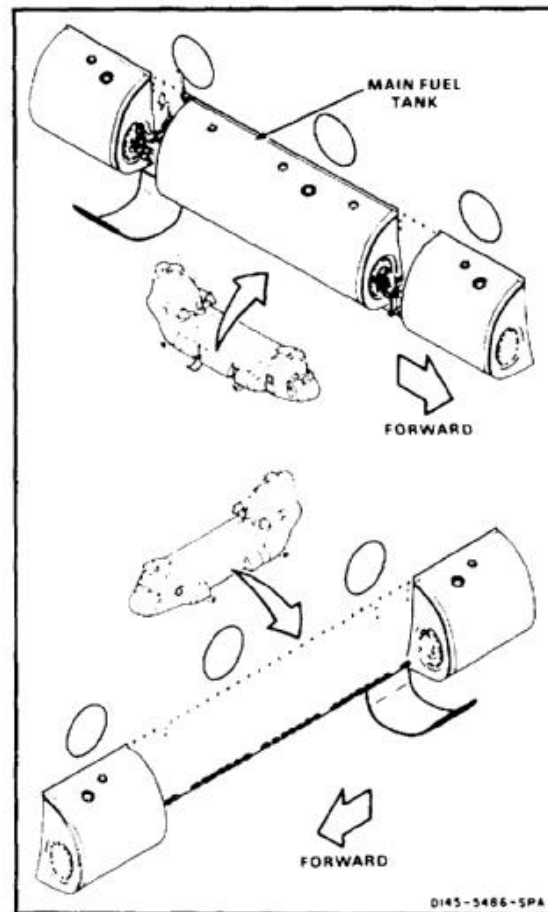

NOTE

Procedure is same to install main fuel tank in No. 1 or No. 2 fuel system. Installation of No. 1 (left) fuel tank is shown here.

INSTALL FUEL TANK ON HINGES

1. With aid from helper, position tank (1) on padded support (2) at side of helicopter. Align fuselage hinge half (3) with tank hinge half (4).
2. Install four hinge pins (5, 6, 7, and 8).
3. Install lockwire at five place (9) to secure hinge pins (5, 6, 7 and 8). Use lockwire (E232).
4. Connect two cable plugs (10).
5. Slide sleeves (11) over plugs (10) and tank sleeves (12). Secure sleeves with tiedown straps (E375) (13).

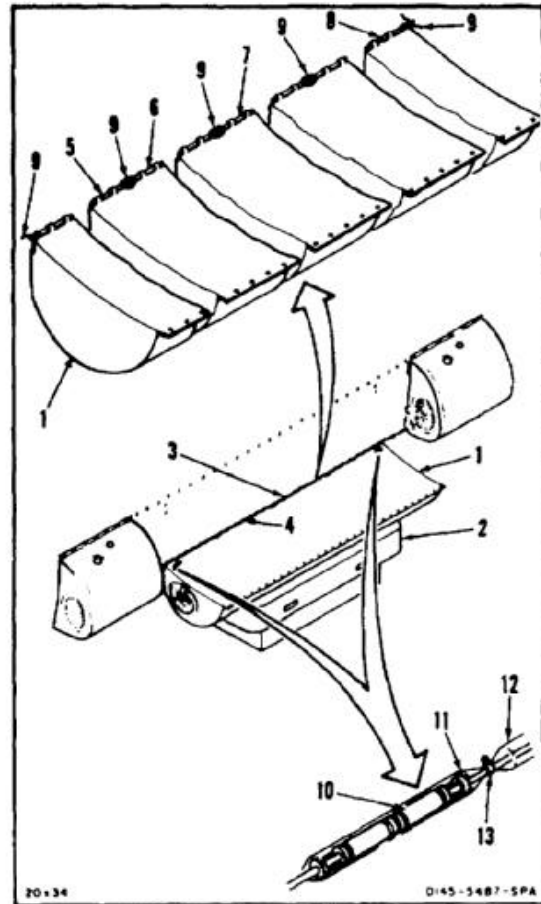

INSTALL MAIN FUEL TANK

6. Clean beam (14) and top edge (15) of tank (1). Use dry cleaning solvent (E162) and cloths (E135). Wear goggles to protect eyes. Use gloves (E184.1).
7. Apply thin coat of parting agent (E307) along beam (14). Use tongue depressor (E424).
8. Apply sealant (E336) along top inside edge of tank (15). Use tongue depressor (E424). Wear gloves (E184.1).
9. With aid from helpers, raise tank (1) and position it against beam (14).
10. Install 37 bolts (17) and washers (16). Apply sealant (E336) over head of bolts.
11. Apply a bead of parting agent (E307) and then sealant (E336) along top outside edge of tank (1) where tank (1) meets skin of aircraft.
12. Install four washers (18) and bolts (19).
13. Remove padded support (2).

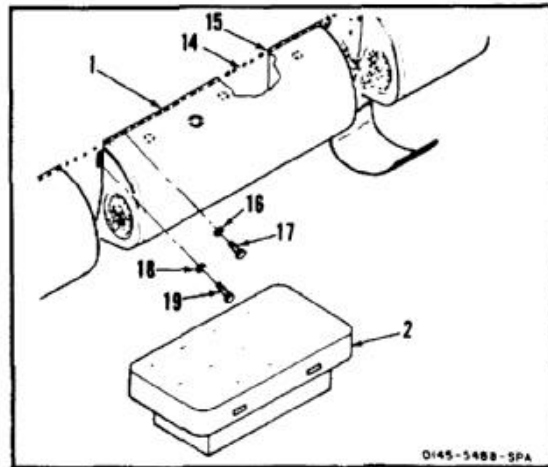

14. Remove barrier material and masking tape from flange of fittings (20 and 21). Clean face of each flange. Use dry cleaning solvent (E162) and cloths (E135). Wear goggles to protect eyes. Wear gloves (E184.1).
15. Position gasket (22), elbow (23), and tee (24). Install four bolts (25), washers (26), and nuts (27).
16. Position gasket (28). Slide elbow (23) forward from adapter (29). Install four bolts (30), washers (31), and nuts (32).

CAUTION

Do not allow fittings or elbows to turn when connecting fuel hoses to fittings on aft access panel. Otherwise, fittings can fail and cause blockage.

17. Remove cap from tee (24) and plug from hose (33). Install conical seal (33.1) in hose fitting. Hold tee with wrench and connect hose to tee.
18. Remove cap from fitting (34) and plug from hose (35). Hold fitting with wrench and connect hose to fitting.
19. Remove cap from fitting (36) and plug from hose (37). Install conical seal (37.1) in hose fitting (37). Hold fitting with wrench and connect hose to fitting.
20. Connect electrical connector (38).
21. Connect hook (38.1) from bracket (38.2) to lanyard on electrical connector (38).

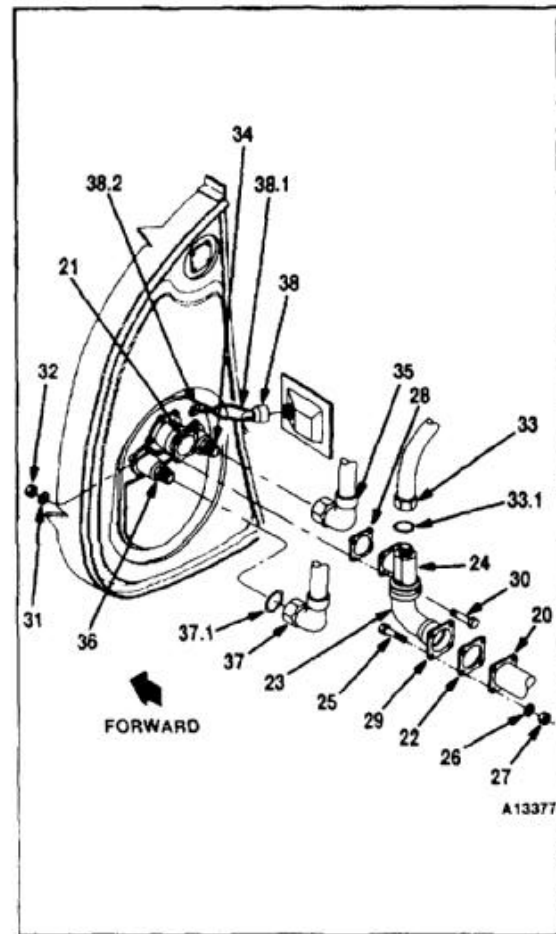

22. Position gaskets (39 and 40). Slide manifold (41) aft from adapter (42).
23. Install eight bolts (43), washers (44), and nuts (45).
24. Remove cap from fitting (46) and plug from hose (47). Hold fitting (46) with wrench and connect hose (47) to fitting.
25. Connect electrical connector (48).
26. Connect hook (48.1) to the lanyard on electrical connector (48) and bracket (48.2).

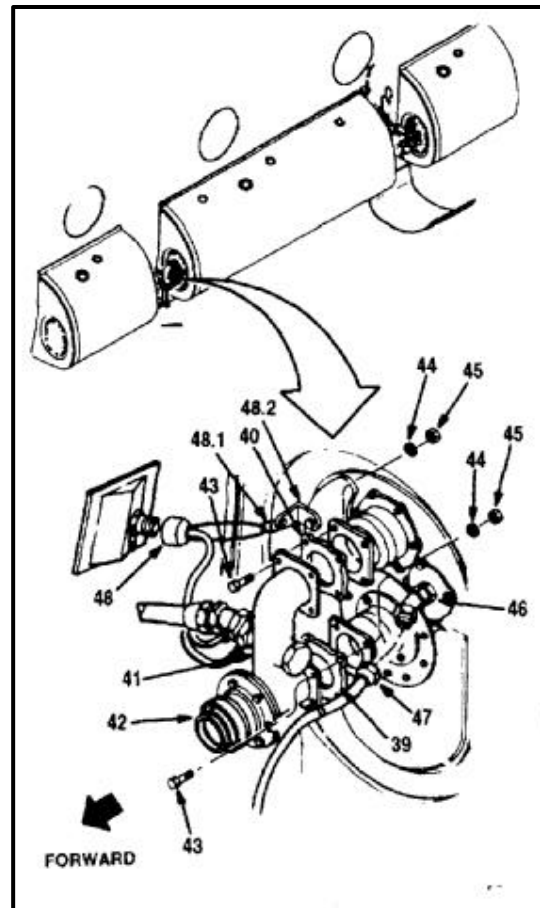
INSPECT**FOLLOW-ON MAINTENANCE:**

- Test main tank after installation (Task 10-22).
- Perform vent system pressure test (Task 10-117) and flow test (Task 10-118) on affected tank.
- Perform test of pressure refueling system (Task 10-119) and fuel feed system (Task 10-120).
- Refuel all tanks (Task 1-51).
- Check for leaks (Task 10-4).
- Bleed fuel system (Task 10-121).
- Perform operational check of affected fuel system (TM 55-1520-240-T).
- Install forward landing gear access panel (Task 2-179 or 2-181).
- Close and secure aft intertank pod panel (Task 2-188).
- Install main fuel tank vent fairing (Task 10-64).

END OF TASK

INITIAL SETUP

Applicable Configurations:

All

Tools:

Aircraft Mechanic's Tool Kit, NSN 5180-00-323-4692
 Nitrogen Supply With Regulator (Preferred) or Low Pressure Air Source (0-120 psig dry/filtered)
 Air Regulator Assembly, NSN 4940-00-200-2096
 Hose, Air, General Purpose, NSN 4720-00-289-3429
 Vent Valve, NSN 4820-00-720-4488
 Shutoff Valve, NSN 4820-01-015-6690
 Low Pressure Air Gage, 0-15 psig, NSN 6685-00-729-4434
 High Pressure Air Gage, 0-60 psig, NSN 6685-00-609-6376
 Stopwatch/Timer
 Plug, MITPK, 114200
 Hose Clamps, NSN 4730-00-965-7503
 Tee, Pipe, NSN 4730-00-278-3990
 Adapter, Straight, Pipe to Hose, NSN 4730-00-287-1876

Materials:

Brush (E85)
 Soap (E353)
 Petrolatum (E274)

Parts:

Packings

Personnel Required:

Medium Helicopter Repairer
 Inspector

References:

Task 10-40
 Task 10-41
 Task 10-42
 Task 10-51
 Task 10-52
 Task 10-81
 Task 10-82
 Task 10-93
 Task 10-94

Equipment Condition:

Battery Disconnected (Task 1-39)
 Electrical Power Off
 Helicopter Grounded (Task 1-29)
 Affected Side of Helicopter Defueled (Task 10-34 or 10-35)
 Forward Landing Gear Access Panel Open (Task 2-2)
 Aft Intertank Pod Panel Open (Task 2-185)
 Vent System Pressure Tested (Task 10-117)

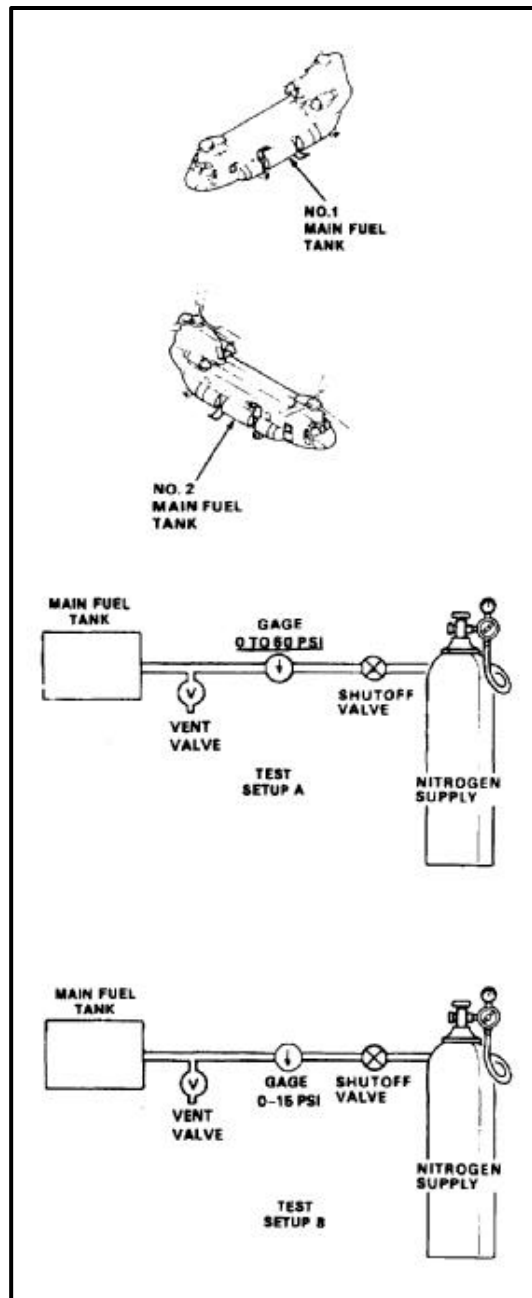

General Safety Instructions:**WARNING**

All regulation and instruction for handling fuels shall be strictly observed.

CAUTION

Do not allow fittings or elbows to turn when connecting fuel hose to fittings on access panels. Otherwise, access door fitting can fail and cause blockage.

NOTE

Procedure is same to test No. 1 (left) or No. 2 (right) main fuel tank. No. 1 tank is shown here.

TEST SETUP A**TEST TANK FUEL SUPPLY SYSTEM**

1. Hold fitting (1) with wrench and disconnect hose (2). Remove conical seal (2.1) from fitting (2.2). Plug fitting.

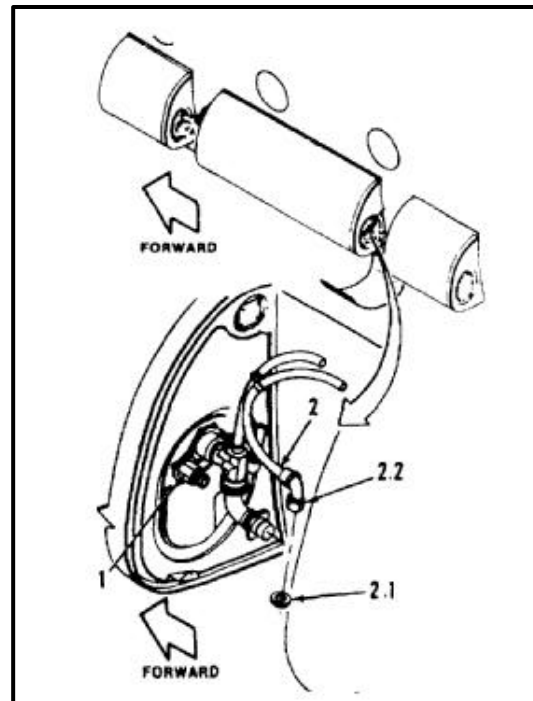

- 1.1. Ensure nitrogen/air supply regulator output pressure is **0 psi**.
2. Make sure valves (3 and 4) are closed. Connect test setup to fitting (1). Open nitrogen/air supply source and regulate pressure to **2 psi** at tank regulator (6).
3. Open valve (3) and allow pressure to stabilize.



Structural damage to aircraft may occur if more than **4.0 psi** is applied.

- 3.1. Increase pressure at regulator (6) and allow to stabilize at **3.0 psi**. Close valve (3).
4. Wait **5 minutes**. Check gage (5). If gage indicates **2.5 psi** or more, go to step 7.
5. If gage (5) reads less than **2.5 psi**, check test setup connections at valves (3 and 4), and gage (5). Use mixture of soap (E353) and water, and brush (E85). Keep system under pressure for **15 minutes**. If bubbles grow in size, connection is leaking. Tighten connections or replace packings as needed. Also check all joints, seams, and cast components.
6. Repeat steps 3 thru 4. If pressure is less than **2.5 psi**, perform steps 7 and 8 and remove fuel lines (Task 10-41). Check lines and connections. Replace packing if needed. Install lines (Task 10-42). Repeat steps 3 thru 5.
7. Shut off nitrogen/air supply (7). Open valve (4) to reduce pressure to **0 psi**. Close valve (4).
8. Disconnect test setup from fitting (1). Cap fitting.

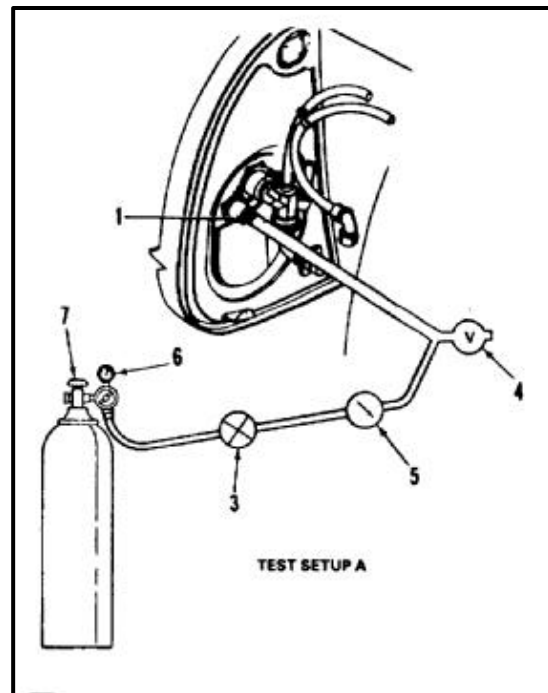

TEST FUEL TANK

9. Hold fitting (6) with wrench and disconnect hose (7). Cap fitting.

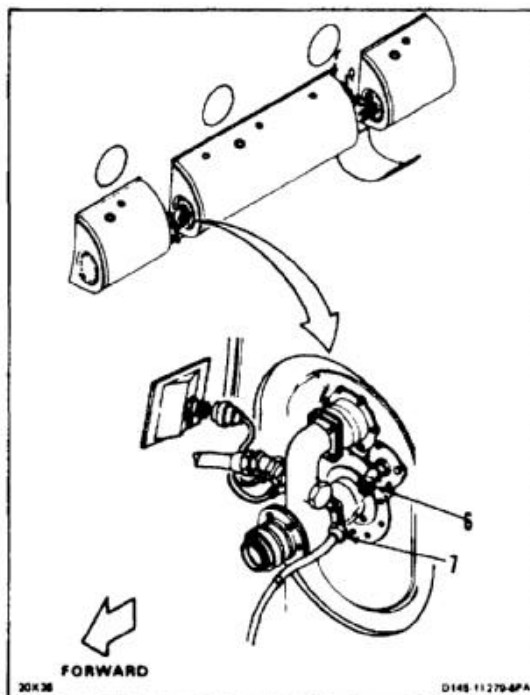

10. Remove drain valve (8) and two packings (9 and 10) (Task 10-93). Install plug in port (11).

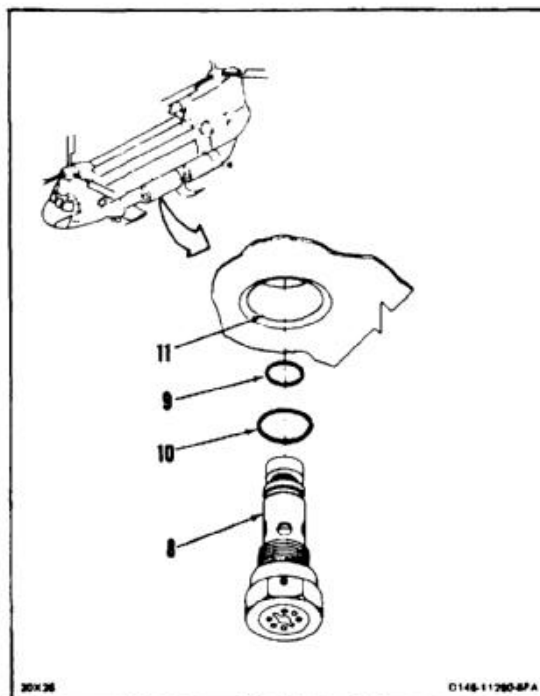

11. Hold fitting (12) with wrench and disconnect hose (13). Remove conical seal (12.1) from hose fitting (12.2).

TEST SETUP B

12. Connect test setup B to fitting (12).

WARNING

Do not allow pressure to exceed **5.0 psi**. Damage to helicopter will occur.

13. Open valve (3) and allow pressure to stabilize at **2 to 4 psi**. Close valve. Record gage (14) indications.
14. Wait **15 minutes**. Check gage. If there is no change in pressure, go to step 21. If pressure has dropped, go to step 16.

CHECK FOR LEAKS

15. Check for leaks as follows:
 - a. Check test setup connections upstream and downstream of drain valve (3), shutoff valve (4), and gage (14). Use mixture of soap (E353) and water, and brush (E85). Tighten connections or replace packings as needed. Repeat steps 13 and 14.

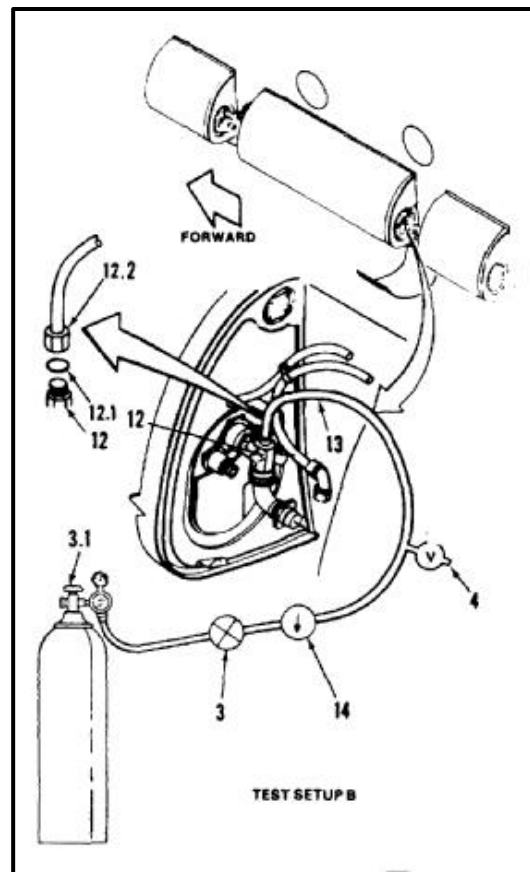

- b. Check forward breakaway fittings (15, 16 and 17), manifold (18), tee (19), and two elbows (20). Apply soap mixture as in step 15a. Secure fittings, manifold, or elbows. Replace packings, if needed. If leak is found, repeat steps 13 and 14.
- c. Check filler adapter (21). Apply soap mixture as in step 15a. Secure filler adapter, or replace packing if needed. If leak is found, repeat steps 13 and 14.

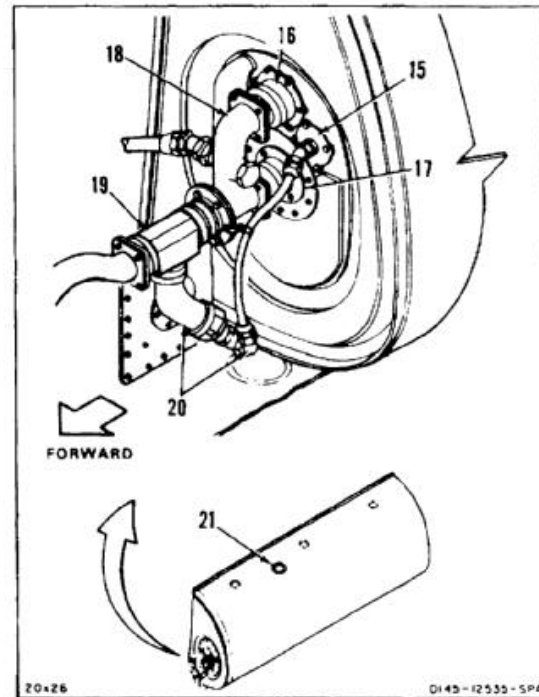

- d. Check three flanges (22). Apply soap mixture as in step 15a. Secure flanges or replace packing, if needed. If leak is found, repeat steps 13 and 14.
- e. Check two closure plates (23) at ends of tank (24). Apply soap mixture as in step 15a. Secure closure plates or replace packings if needed. If leak is found, repeat steps 13 and 14.
- f. Check aft breakaway fittings (25, 26 and 27). Apply soap mixture as in step 15a. Secure fittings or replace packings, if needed. If leak is found, repeat steps 13 and 14.
- g. Check two access doors (28). Apply soap mixture as in step 15a. Secure access doors or replace packings, if needed. If leak is found, repeat steps 13 and 14.
- h. If no leakage is found in steps 15a thru g, go to step 21. If leaks are still found, go to step 16.

CHECK FOR LEAKS INSIDE TANK

16. Remove probe (22) and gasket (Task 8-81). Check inside of flange (22.1). Check underside of gasket and sealing surfaces. Install probe (Task 8-82). If leak is found, repeat steps 13 and 14.

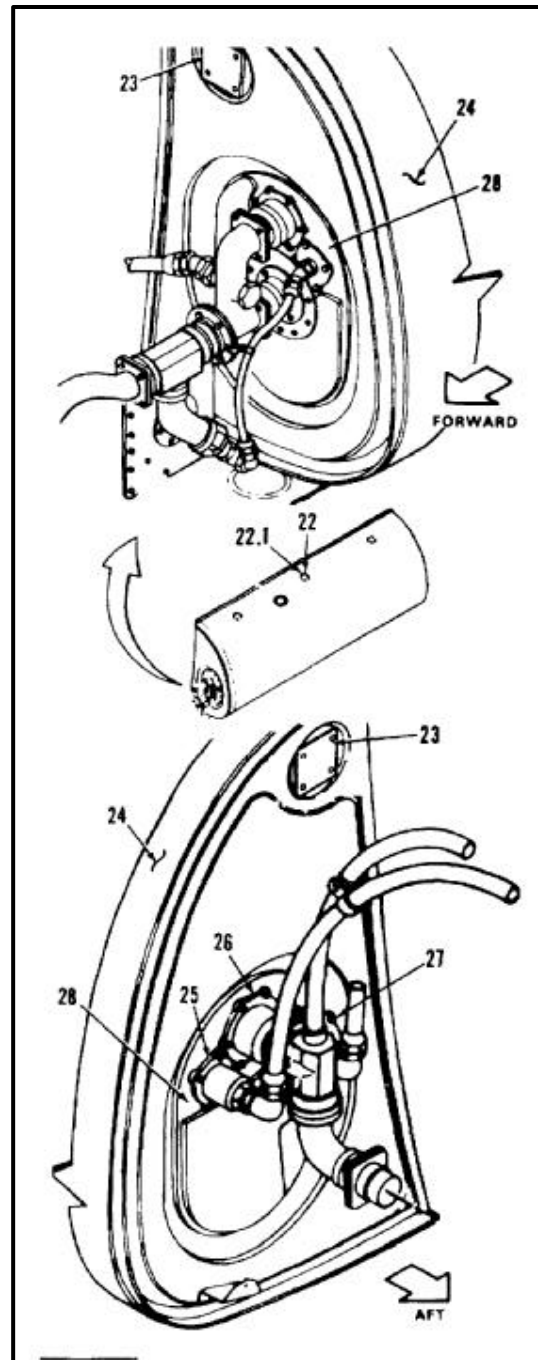

17. Check inside of filler adapter (13) as follows:
- Remove six bolts (29) and washers (30), adapter (13), and gasket (31).
 - Remove three screws (32). Remove packing (33).
 - Check sealing surfaces between cell (34) and pod (35).
 - Coat packing (33) with petrolatum (E274). Install packing carefully in annular groove of cell flange (36). Make sure packing is not disturbed during positioning of fuel cell (34) in pod (35).
 - Align hole (37) in cell (34) with hole (38) in pod (35). Install three screws (32).
 - Position gasket (31) and filler adapter assembly (13). Install six bolts (29) and washers (30). Torque bolts to **60 to 80 inch-pounds**.
 - Repeat steps 13 and 14.

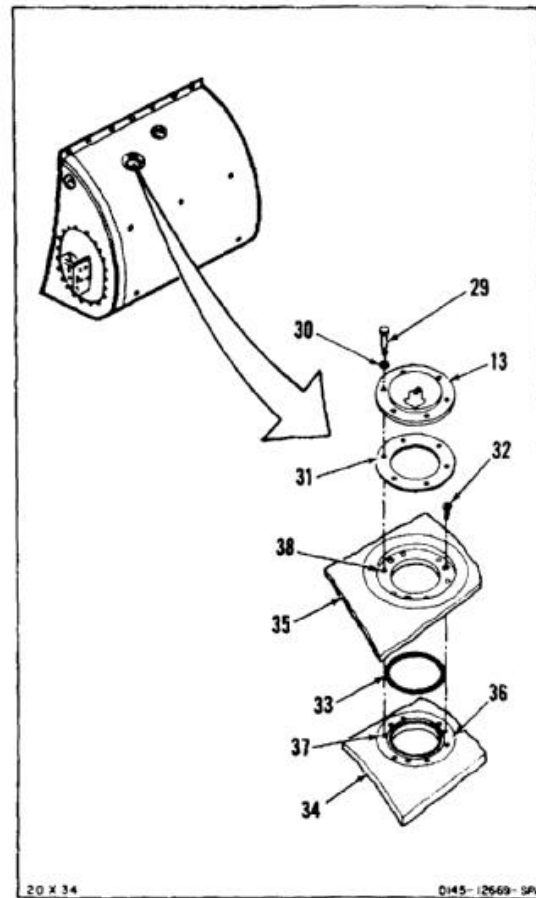

18. Check inside of forward closure plate (23) as follows:
 - a. Remove four bolts (39), washers (40), and packing (41).
 - b. Remove two screws (42) and packing (43).
 - c. Coat packing (43) with petrolatum (E274). Install packing carefully in annular groove of flange (44). Make sure packing is not disturbed during positioning of fuel cell (34) in pod (35).
 - d. Align holes (45) with holes (46). Install two screws (42).
 - e. Coat packing (41) with petrolatum (E274). Install packing carefully in annular groove of pod flange (47). Position closure plate (23) on tank pod (35).
 - f. Install four bolts (39) and washers (40). Torque bolts to **60 to 80 inch-pounds**.
 - g. Repeat steps 13 and 14.
19. Check inside of forward access door (28).
 - a. Remove access door (28) (Task 10-51).
 - b. Remove four screws (48). Remove gasket (49).
 - c. Lightly smear both sides of gasket (49) with petrolatum (E274).
 - d. Position gasket between pod (35) and cell (34).
 - e. Align pod (35), gasket (49), and cell (34). Install four screws (48).
 - f. Install access door (28) (Task 10-52).
 - g. Repeat steps 13 and 14.
20. Repeat steps 18 and 19 at aft end of tank (24).

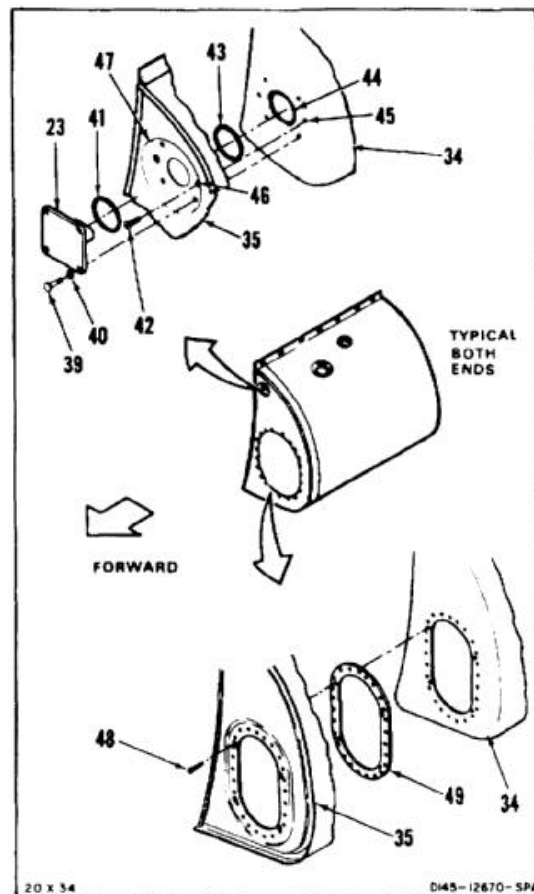

21. Open vent valve (4) and reduce pressure to **0 psi**.
22. Disconnect test setup B from fitting (12).
23. Install conical seal (12.1) in hose fitting (12). Hold fitting with wrench and connect hose (13).
24. Remove cap from fitting (1) and plug from hose (2). Install conical seal (2.1) in hose (2) fitting. Hold fitting with wrench and connect hose.

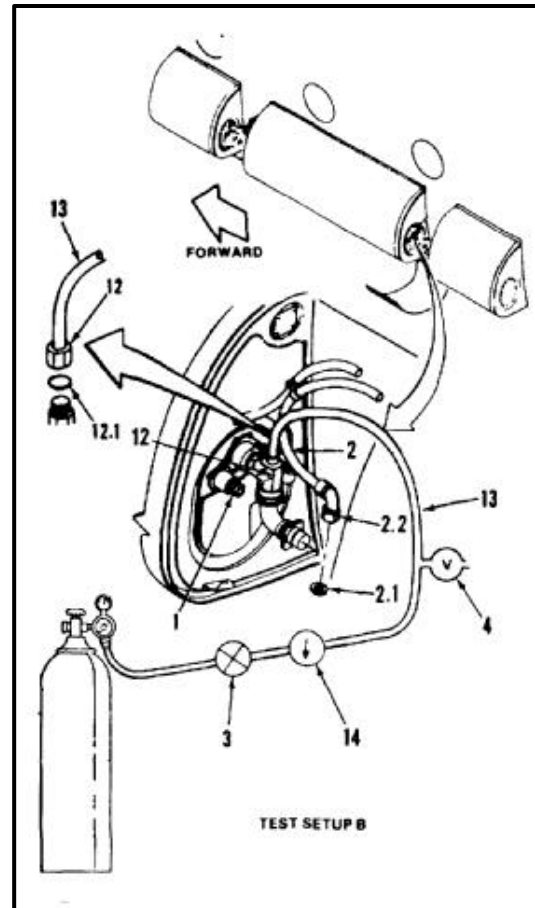

25. Remove plug from port (11). Install two packings (9 and 10) on valve (8). Install valve in port (Task 10-40).

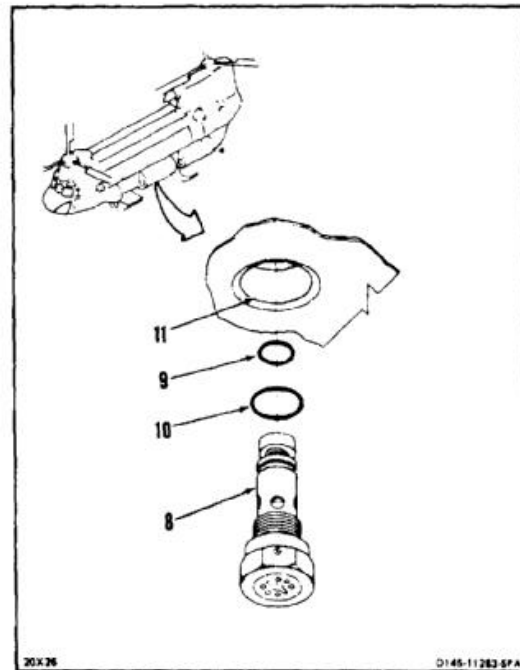

26. Remove cap from fitting (6) and plug from hose (7). Hold fitting with wrench and connect hose.

INSPECT

FOLLOW-ON MAINTENANCE:

- Perform vent system flow test (Task 10-118) on affected tank.
- Perform test of pressure refueling system (Task 10-119) and fuel feed system (Task 10-120).
- Refuel main tank (Task 1-51).
- Check for leaks (Task 10-4).
- Bleed fuel system (Task 10-121).
- Perform operational check of affected fuel system (TM 55-1520-240-T).
- Close forward landing gear access panel (Task 2-2).
- Close aft intertank pod panel (Task 2-188).

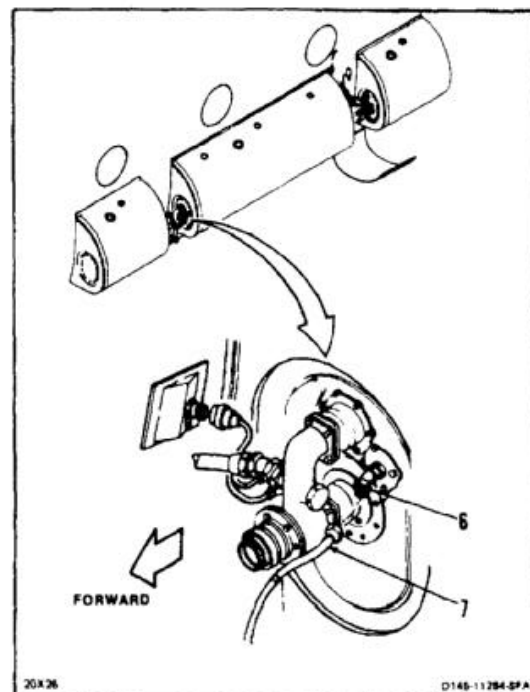

END OF TASK

10-23 REMOVE FORWARD FUEL TANK**10-23****INITIAL SETUP****Applicable Configurations:**

All

Tools

Aircraft Mechanic's Tool Kit, NSN 5180-00-323-4692
 Padded Support
 Wrench, Open End, 1-1/2 Inch
 Wrench, Open End, 1-7/8 Inch
 Grounded Container, 2 Quart or Equivalent

Materials:

Cloths (E135)
 Penetrating Lubricant (E236)
 Barrier Material (E80)
 Tape (E388)

Personnel Required:

Medium Helicopter Repairer (2)

References:

Task 1-22
 Task 2-107

Equipment Condition:

Battery Disconnected (Task 1-39)
 Electrical Power Off
 Helicopter Grounded (Task 1-29)
 All Fuel Tanks Defueled (Task 10-34 or 10-35)
 Fuel Tank Purged (Task 10-2)
 Forward Landing Gear Access Panel Removed (Task 2-178 or 2-180)
 Forward Landing Gear Outboard Wheel Removed (Task 3-9)

General Safety Instructions:**WARNING**

All regulations and instructions for handling fuels shall be strictly observed.

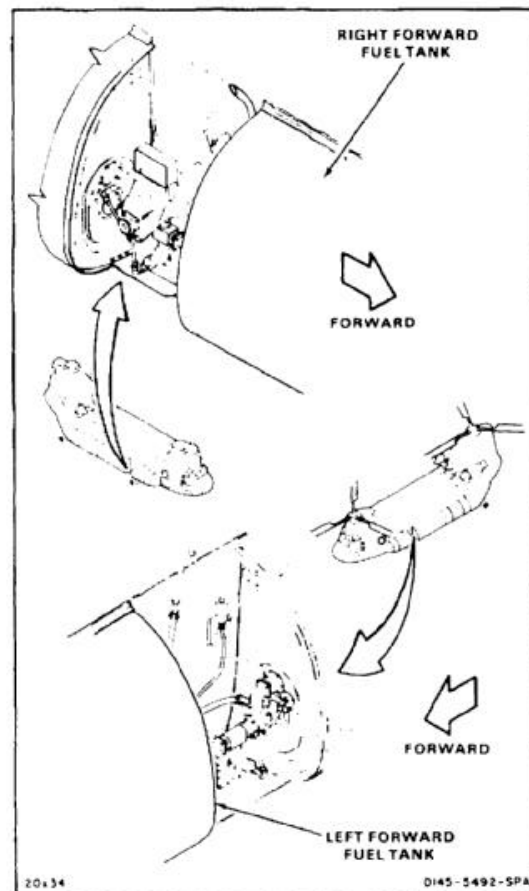

NOTE

Procedure is same to remove forward fuel tank in No. 1 or No. 2 fuel system. Removal of No. 1 (left) tank is shown here.

LOWER FUEL TANK ON HINGES

1. Disconnect electrical connector (1).
- 1.1. Disconnect hook (1.1) at the lanyard on the electrical connector (1) from bracket (1.2).



Do not allow elbows or nipples to turn when disconnecting fuel hoses from aft access panel. Otherwise, fittings can fail and cause fuel blockage.

2. Hold elbow (2) with wrench and disconnect vent hose (3). Plug hose and cap elbow.
3. Hold elbow (4) with wrench and disconnect hose (5). Remove conical seal (5.1) from hose (5) fitting. Plug hose and cap elbow.
4. Hold nipple (6) with wrench and disconnect hose (7). Plug hose and cap nipple.
5. Remove eight nuts (8), washers (9), and bolts (10).
6. Slide adapter (11) aft.
7. Remove two gaskets (12) and tube (13).
8. Cover hole in flange of adapter (11). Use barrier material (E80) and tape (E388).
9. Cover hole in flange of fitting (14). Use barrier material (E80) and tape (E388).

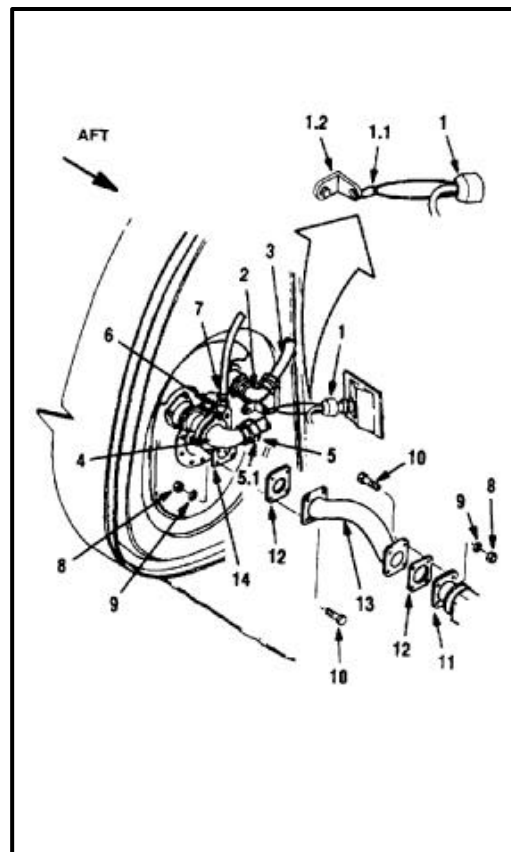

10-23 REMOVE FORWARD FUEL TANK (Continued)**10-23**

10. Remove 54 screws (15) and washers (16) from splice plate (17).

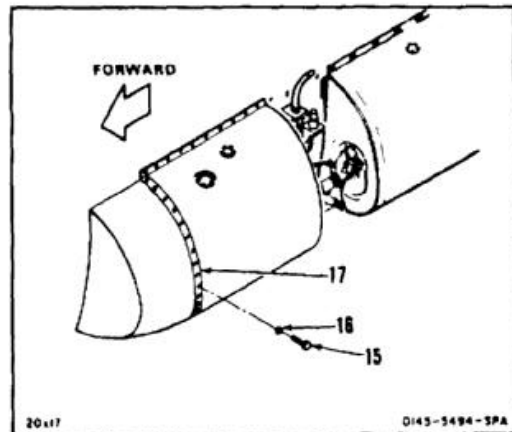

11. Remove cabin side acoustic blanket (18) (left side, forward of sta. 200 and below waterline 0) (Task 2-107).
12. Remove two bolts (19) and washers (20).

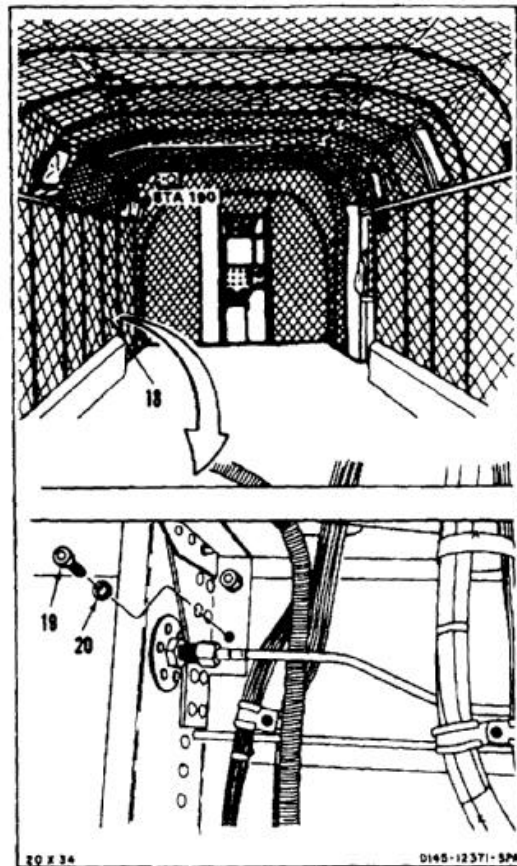

13. Remove two bolts (21) and washers (22).

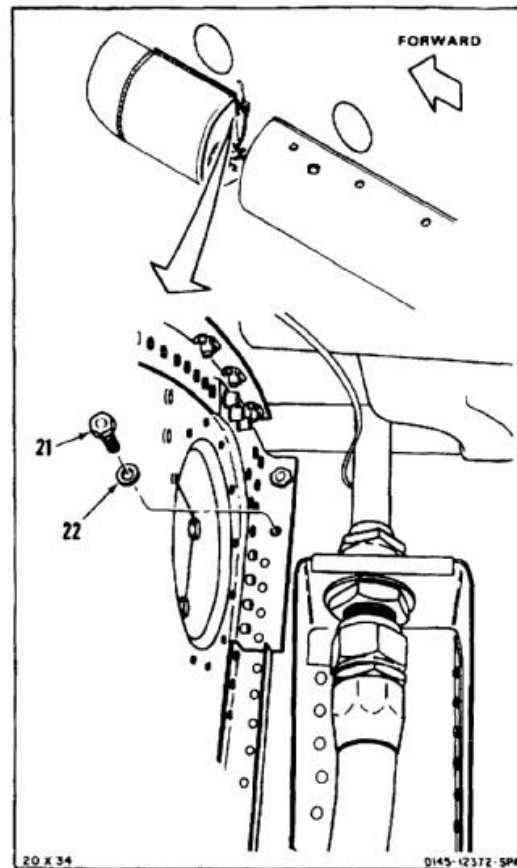

14. Jack helicopter at forward fuselage jack pad (Task 1-22).
15. Position padded support (23) at side of tank (24). Make sure padded support prevents tank from touching any part of helicopter.
16. Have helper support tank (24). Remove 17 bolts (25) and washers (26).

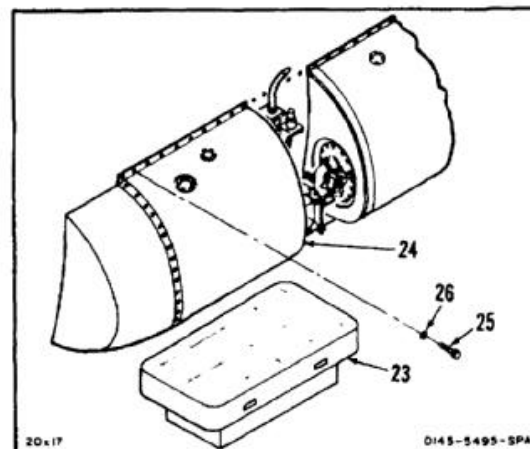

10-23 REMOVE FORWARD FUEL TANK (Continued)**10-23**

17. Lower tank (24) on hinge (27), onto padded support (23).

REMOVE FUEL TANK

18. Remove two straps (28) from sleeves (29).
 19. Disconnect two cable plugs (30).
 20. Spray hinge (27) with penetrating lubricant (E236).
 21. Cut lockwire at three places (31) and remove two hinge pins (32 and 33).
 22. Remove tank (24).

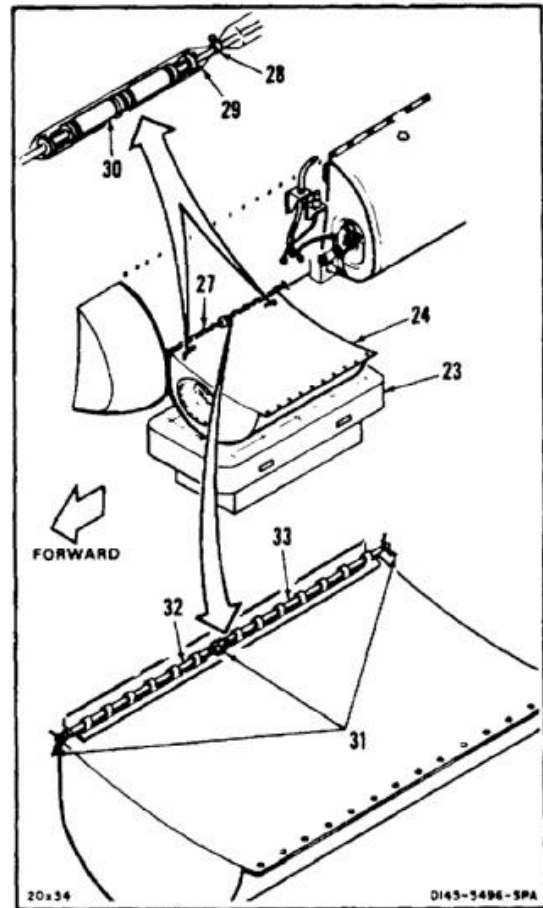
**FOLLOW-ON MAINTENANCE:**

None

END OF TASK

INITIAL SETUP

Applicable Configurations:

All

Tools:

Aircraft Mechanic's Tool Kit, NSN 5180-00-323-4692

Materials:

None

Personnel Required:

Medium Helicopter Repairer

Equipment Condition:

Battery Disconnected (Task 1-39)
 Electrical Power Off
 Forward Fuel Tank Removed (Task 10-23)
 Fuel Quantity Indicating System Tank Unit Removed
 (Task 8-81)
 Forward Fuel Tank Boost Pump Removed (Task
 10-69)
 Forward Tank Fuel Lines and Electrical Wiring
 Removed (Task 10-67)
 Forward Tank Vent Assembly Removed (Task 10-65)
 Fuel Level Control Valve and Mounting Bracket
 Removed (Task 10-59)
 Tank Drain Valves Removed (Task 10-39)
 Forward Fuel Tank Vent Valve Removed (Task 10-73)

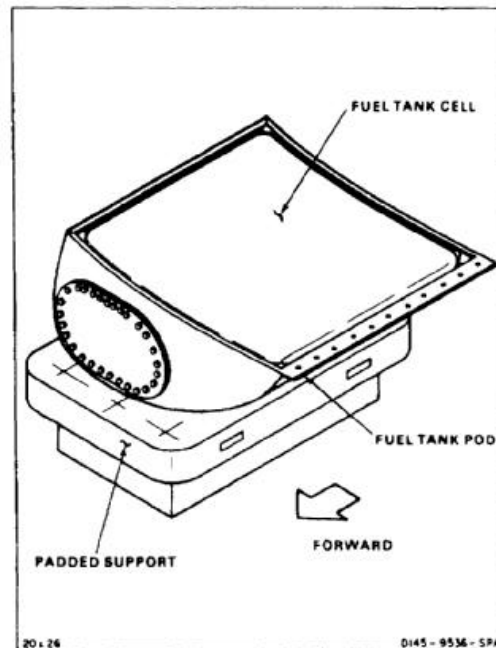
**General Safety Instructions:****WARNING**

All regulations and instructions for handling fuel shall be strictly observed.

CAUTION

Do not puncture or scratch lining of fuel tank. If lining is broken, fuel penetrates and activates self-sealing layers. Activated layers swell and trap fuel. Activated green spongy material also contaminates fuel system. This makes it necessary to replace fuel tank and flush fuel system.

NOTE

Procedure is same to remove cell from No. 1 or No. 2 forward fuel tank. Removal of No. 1 (left) cell is shown here.

REMOVE BOOST PUMP BRACKET

1. Remove four bolts (1) and washers (2).
2. Remove pump bracket (3).

NOTE

Four different types of forward fuel cells are used on the helicopter. Each is interchangeable and there may be washers or bushings installed between pump bracket and cell.

3. Remove four washers (4) or bushings (5) as necessary.
4. Remove four bolts (6) and washers (7) at both ends of cell.
5. Remove packing (8) between fuel pod (9) and fuel cell (10) at both ends of cell.

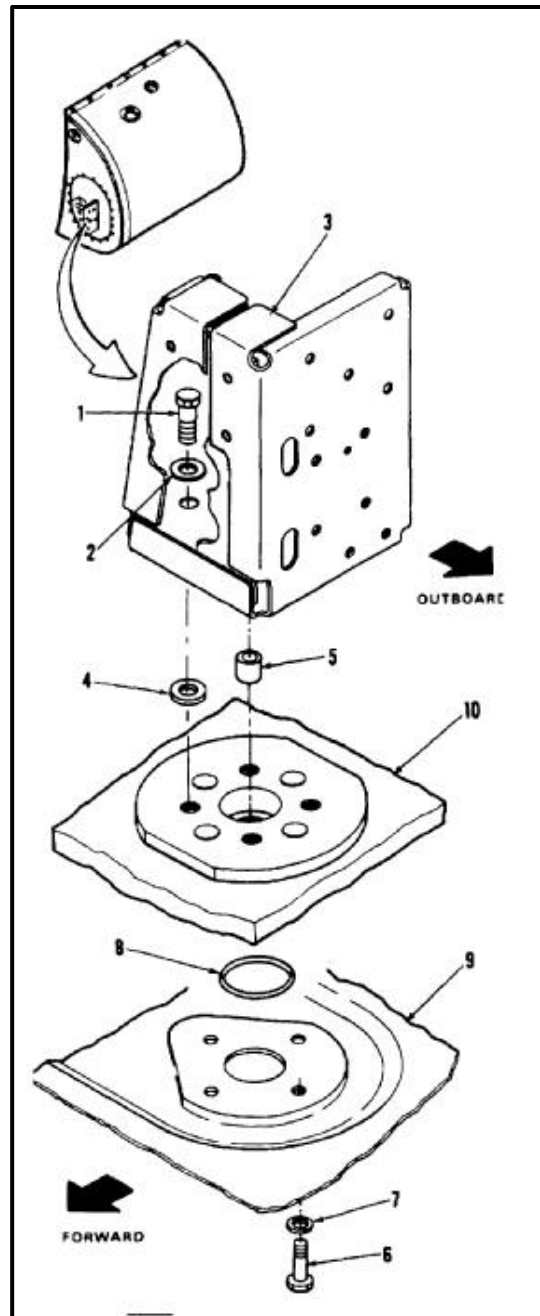

NOTE

Removal of closure plate and access hole gasket is same at both ends of tank.

6. Remove four screws (11) and washers (12). Remove closure plate (13) and packing (14).
7. Remove two screws (15) and packing (16).
8. Remove four screws (17). Remove gasket (18) between fuel pod (9) and fuel cell (10).

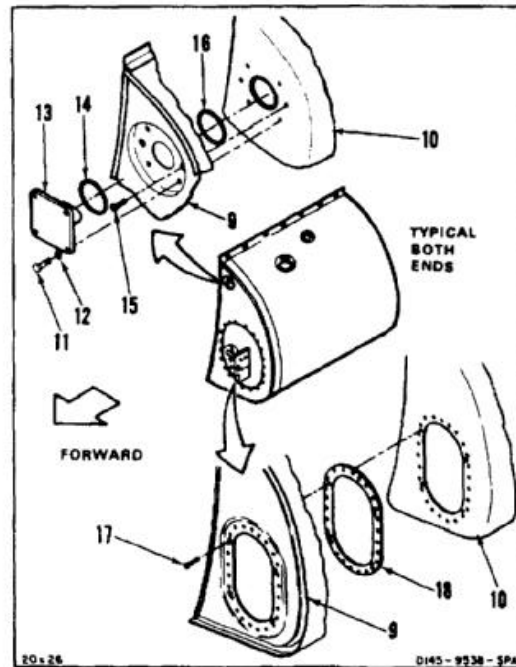

9. Remove two screws (19). Separate fuel cell (10) from fuel pod (9). Remove gasket (20).
10. Remove six bolts (21) and washers (22).
11. Remove filler adapter assembly (23) and gasket (24).
12. Remove three screws (25). Separate fuel cell (10) from fuel pod (9). Remove packing (26).
13. Remove three bolts (27) and washers (28).

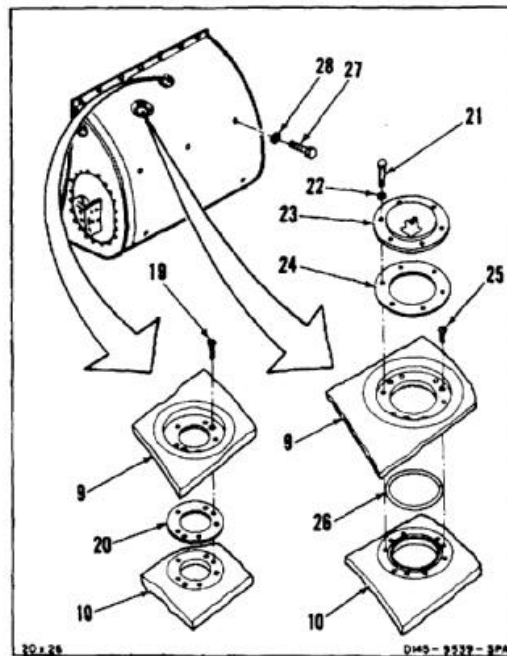

14. Carefully remove fuel cell (10) from pod structure (9).

FOLLOW-ON MAINTENANCE:

None

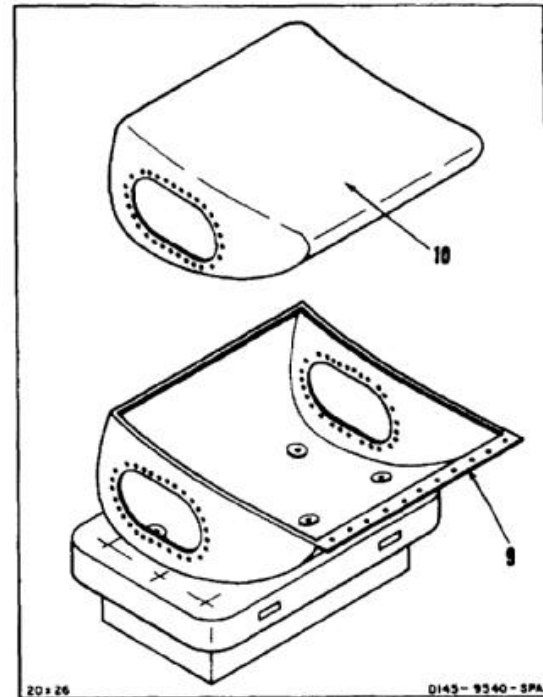

END OF TASK

INITIAL SETUP

Applicable Configurations:

All

Tools:

- Drill Size O
- Drill Size F
- Aircraft Mechanic's Tool Kit, NSN 5180-00-323-4692

Materials:

- Lockwire (E232)
- Epoxy Primer (E292.1)
- Gloves (E184.1)

Personnel Required:

- Structural Repairer (2)
- Inspector

References:

- TM 55-1520-240-23P
- Task 10-25
- Task 10-26

Equipment Condition:

- Forward Left or Right Fuel Tank Removed (Task 10-23)
- Aft Left or Right Fuel Tank Removed (Task 10-28)

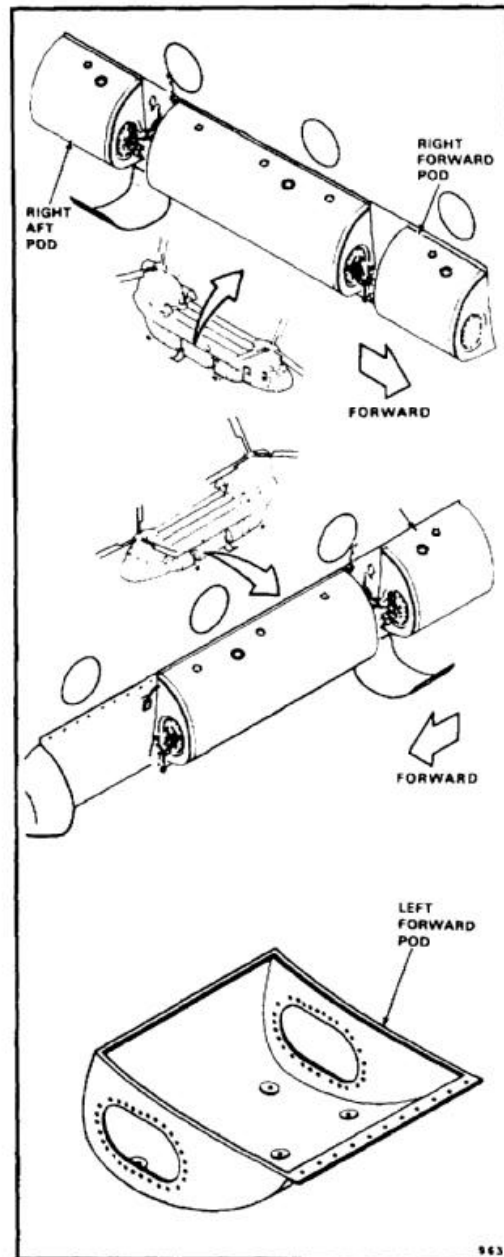

NOTE

Procedure is same to prepare to replace left or right, forward or aft fuel pods. Left, forward pod is shown here.

1. With aid from helper, position pod (1) on padded support (2) at side of aircraft. Align fuselage hinge half (3) with tank hinge half (4).
2. Install two hinge pins (5 and 6) in hinges (3 and 4).
3. Install lockwire at three places (7) to secure hinge pins (5 and 6). Use lockwire (E232).

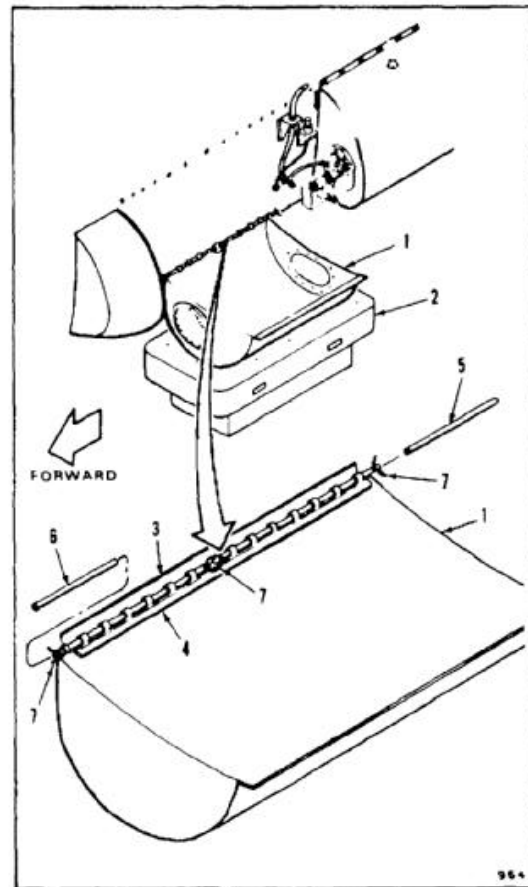

4. Raise pod (1) and position against side of aircraft.
5. Working from inside aircraft, mark 17 bolt holes (8) along top of pod (1), and 4 holes (9) on sides of pod. Use holes in fuselage (10) as a guide.
6. Lower pod (1) on support (2).
7. Drill 17 holes (8) in top support angle (11). Deburr holes. Use drill size F.
8. Drill 4 holes (9) in side support angle (12). Deburr holes. Use drill size O.

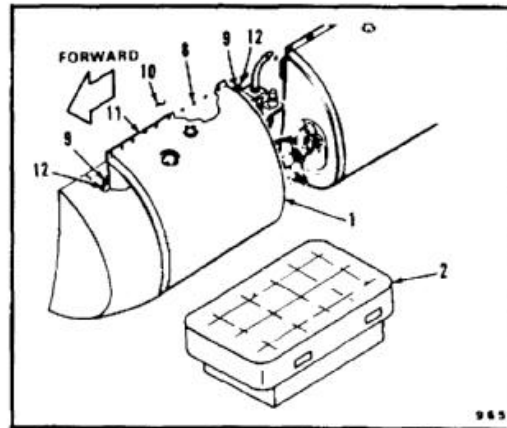
**INSPECT****WARNING**

Epoxy primer (E292.1) is flammable and toxic. It can irritate skin and cause burns. Avoid inhaling. Use only with adequate ventilation. Avoid contact with skin, eyes, or clothing. Keep away from heat, sparks, or open flame. In case of contact, immediately flush skin or eyes with water for at least **15 minutes**. Get medical attention for eyes.

9. Apply epoxy primer (E292.1) to drilled holes (8 and 9). Wear gloves (E184.1).
10. Perform Task 10-25.
11. Perform Task 10-26.

FOLLOW-ON MAINTENANCE:

Perform vent system pressure test (Task 10-117) and flow test (Task 10-118) on affected tank.
 Perform test of pressure refueling system (Task 10-119) and fuel feed system (Task 10-120).
 Refuel helicopter (Task 1-51).
 Bleed fuel system (Task 10-121).
 Perform operational check of affected fuel system (TM 55-1520-240-T).
 Inspect for leaks (Task 10-4).
 Install forward landing gear access panel (Task 2-179 or 2-181).

END OF TASK

INITIAL SETUP

Applicable Configurations:

All

Tools:

Aircraft Mechanic's Tool Kit, NSN 5180-00-323-4692
Torque Wrench, 30 to 150 Inch-Pounds

Materials:

Petrolatum (E274)

Parts:

Packings
Gaskets

Personnel Required:

Medium Helicopter Repairer
Inspector

References:

Task 10-40
TM 55-1520-240-23P

General Safety Instructions:

Do not puncture or scratch lining of fuel tank. If lining is broken, fuel penetrates and activates self-sealing layers. Activated layers swell and trap fuel. Activated green spongy material also contaminates fuel system. This makes it necessary to replace fuel tank and flush fuel system.

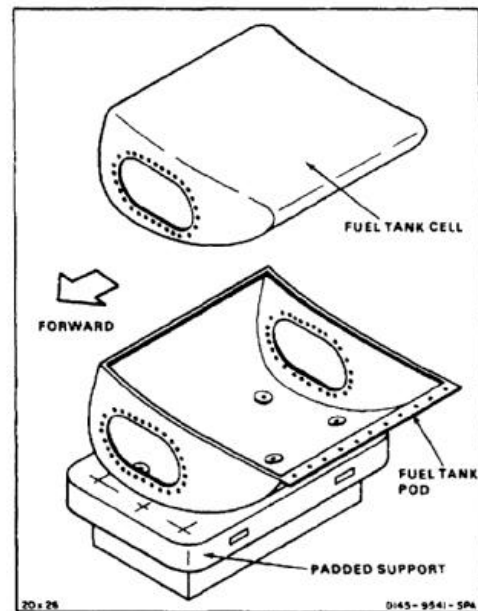

NOTE

Procedure is same to install cell in No. 1 or No. 2 fuel tank pod. Installation of No. 1 (left) cell is shown here.

NOTE

Before installing forward fuel tank check backboard for condition.

1. Make sure interior of fuel tank pod (1) is free of foreign material.
2. Position fuel cell (2) carefully in tank pod (1). Insert lower portion of cell in pod. Depress top portion of cell. Position it in and along top portion of tank pod.
3. Form cell (2) to fit contour of pod structure (1).
4. Install bolt (3) and washer (4). Do not tighten bolt at this time.
5. Install bolts (5 and 6) and washers (4). Do not tighten bolts at this time.
6. Tighten three bolts (3, 5 and 6) in this order.
7. Coat two packings (7) with petrolatum (E274). Install packings carefully in annular groove of flange (8) at each end of tank. Make sure that packings are not disturbed during positioning of fuel cell (2) in pod (1).
8. Align holes (9) in pod (1) with holes (10) in cell (2). Install eight bolts (11) and washers (12). Torque bolts to **60 to 80 inch-pounds**.

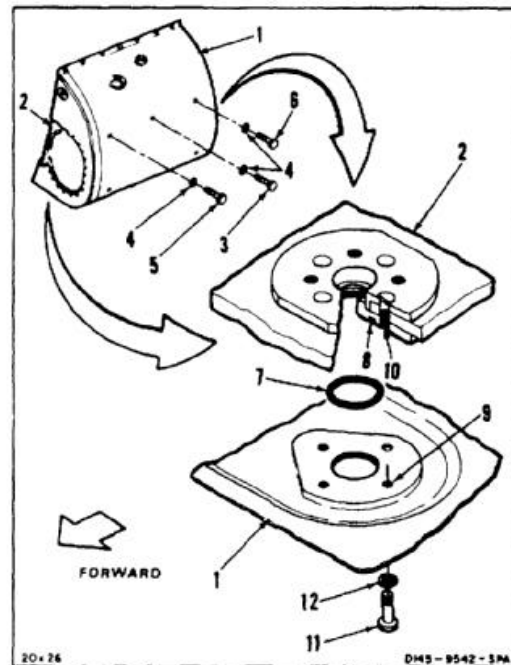

10-25 INSTALL FORWARD FUEL TANK CELL (Continued)

10-25

9. Coat two packings (13) with petrolatum (E274). Install packings carefully in annular groove of flange (14) at each end of cell (2). Make sure packings are not disturbed during positioning of fuel cell in pod (1).
10. Align holes (15) with holes (16). Install two screws (17) at each end of tank pod (1).
11. Coat two packings (18) with petrolatum (E274). Install packings carefully in annular groove of cell flange (19). Position closure plate (20) at each end of tank pod (1).
12. Install four bolts (21) and washers (22). Torque bolts to **60 to 80 inch-pounds**.
13. Coat packings (23) with petrolatum (E274). Install packing carefully in annular groove of cell flange (24). Make sure packing is not disturbed during positioning of fuel cell (2) in pod (1).
14. Align hole (25) in cell (2) with hole (26) in pod (1). Install three screws (27).
15. Position gasket (28) and filler adapter assembly (29). Install six bolts (30) and washers (31). Torque bolts to **60 to 80 inch-pounds**.
16. Position gasket (32) on flange (33) of fuel cell (2). Align holes (34) in fuel cell with holes (35) in pod (1). Install three screws (36).

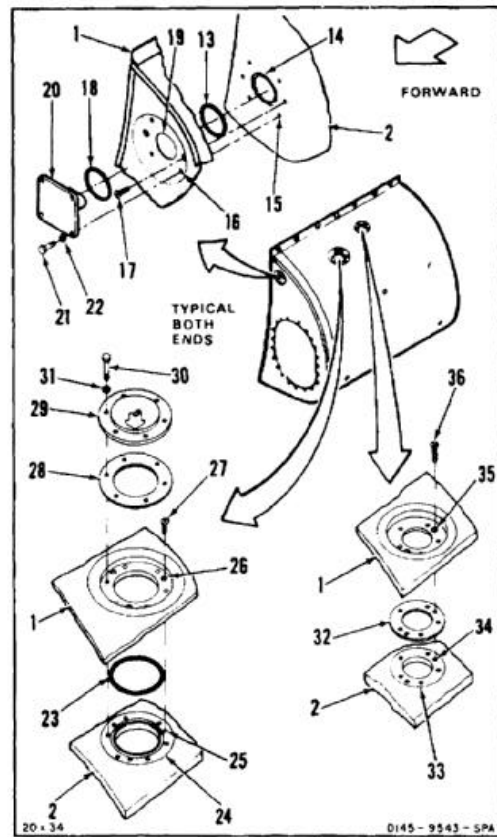

17. Lightly smear both sides of gasket (37) with petrolatum (E274).
18. Position gaskets (37) between fuel pod (1) and fuel cell (2) at both ends of fuel pod.
19. Align fuel pod (1), gaskets (37) and fuel cell (2). Install four screws (38) at each end of tank pod.

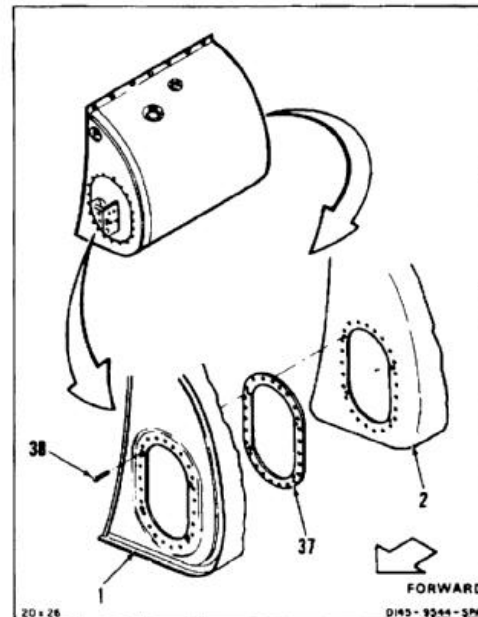

20. Install fuel tank drain valves (Task 10-40).

INSTALL BOOST PUMP BRACKET

NOTE

Four different types of forward fuel cells are used on the helicopter. Each is interchangeable and may require four washers or bushings between pump bracket and cell.

21. For fuel cell 145P4056-1 position four washers (39) on cell flange (40). For fuel cell 145P4056-2 or 414PS401-8 install four bushings (41) on cell flange (40).
22. Position pump bracket (42).
23. Install four bolts (43) and washers (44).

INSPECT

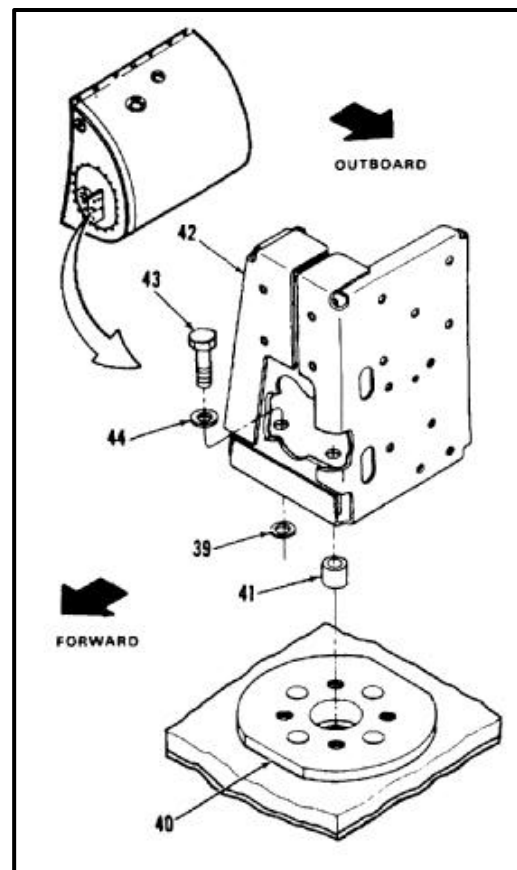

FOLLOW-ON MAINTENANCE:

Install forward fuel tank vent valve (Task 10-74).
Install fuel level control valve and mounting bracket
(Task 10-60).
Install forward fuel tank vent assembly (Task 10-66).
Install forward tank fuel lines and electrical wiring
(Task 10-68).
Install fuel quantity indicating system tank unit (Task
8-82).
Install forward tank boost pump (Task 10-70).
Install forward fuel tank (Task 10-26).

END OF TASK

INITIAL SETUP

Applicable Configurations:

All

Tools:

Aircraft Mechanic's Tool Kit, NSN 5180-00-323-4692
 Wrench, Open End, 1-1/2 Inch
 Wrench, Open End, 1-7/8 Inch

Materials:

Cloths (E135)
 Gloves (E184.1)
 Lockwire (E231)
 Lockwire (E232)
 Dry Cleaning Solvent (E162)
 Tiedown Straps (E375)
 Parting Agent (E307)
 Sealant (E336)
 Tongue Depressors (E424)

Parts:

Gaskets

Personnel Required:

Medium Helicopter Repairer (2)
 Inspector

References:

Task 1-22
 Task 2-108
 Task 3-12
 TM 55-1520-240-23P

General Safety Instructions:**WARNING**

All regulations and instructions for handling fuels shall be strictly observed.

Dry cleaning solvent (E162) is flammable and toxic. It can irritate skin and cause burns. Use only in well-ventilated area, away from heat and open flame. In case of contact, immediately flush skin or eyes with water for at least **15 minutes**. Get medical attention for eyes.

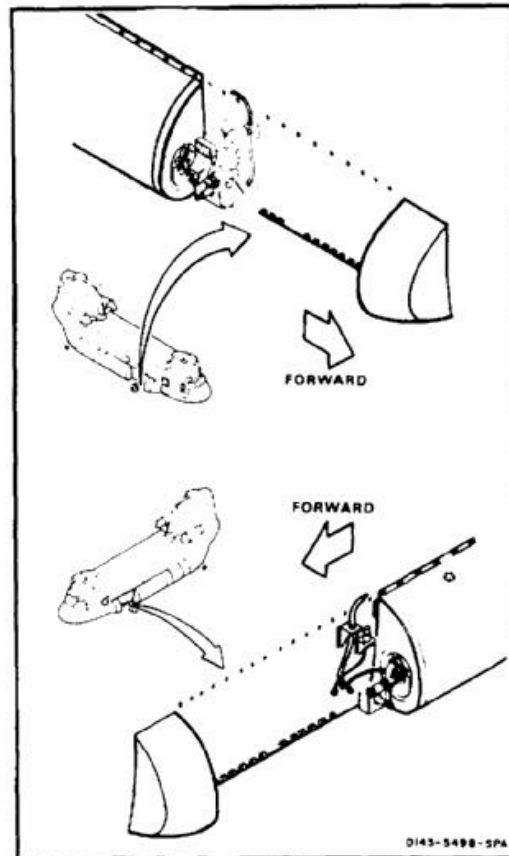
**WARNING**

Parting agent (E307) can form toxic vapors if exposed to flame. Use in well-ventilated area, away from open flame. In case of contact, immediately flush skin or eyes with water for at least **15 minutes**. Get medical attention for eyes.

Sealant (E336) can irritate skin and cause burns. Avoid contact with skin, eyes, and clothing. In case of contact, immediately flush skin or eyes with water for at least **15 minutes**. Get medical attention for eyes.

NOTE

Procedure is same to install forward fuel tank in No. 1 or No. 2 fuel system. Installation of No. 1 (left) tank is shown here.

INSTALL FUEL TANK ON HINGES

1. Position tank (1) on padded support (2) at side of helicopter. Align fuselage hinge half (3) with tank hinge half (4).
2. Install hinge pins (5 and 6) in direction of arrows.
3. Install lockwire at three places (7) in hinge pins (5 and 6). Use lockwire (E232).
4. Connect two cable plugs (8).
5. Slide sleeves (9) over plugs (8) and tank sleeves (10). Secure sleeves with tiedown straps (E375) (11).

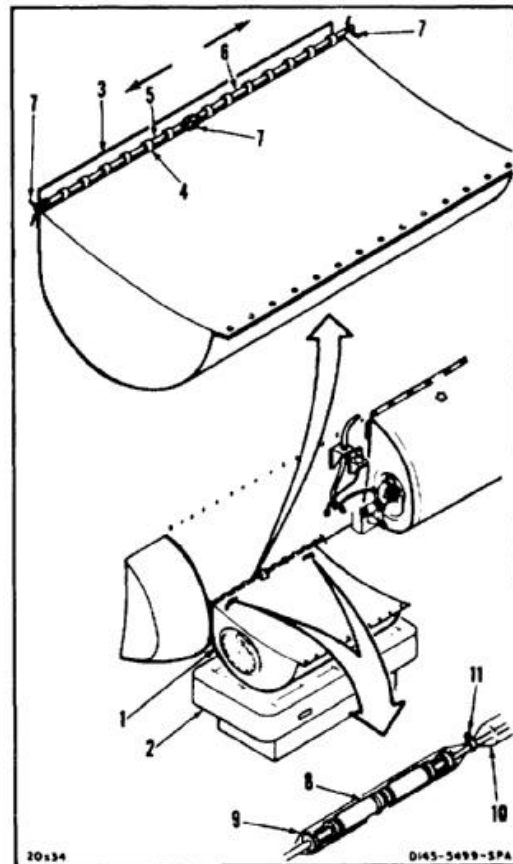

RAISE AND INSTALL FUEL TANK

6. Clean beam (12) and top edge (13) of tank (1). Use dry cleaning solvent (E162) and cloths (E135). Wear goggles to protect eyes. Wear gloves (E184.1).
7. Apply thin coat of parting agent (E307) along beam (12). Use tongue depressor (E424). Wear gloves (E184.1).
8. Apply sealant (E336) on top inner edge of tank (13). Use tongue depressor (E424). Wear gloves (E184.1).
9. With aid from helper, raise tank (1) to installed position and support tank.
10. Install 17 bolts (14) and washers (15). Apply sealant (E336) over head of bolts.
11. Apply a bead of parting agent (E307) and then sealant (E336) along top outside edge of tank (1) where tank meets skin of aircraft.
12. Remove padded support (2).
13. Install two washers (16) and bolts (17).

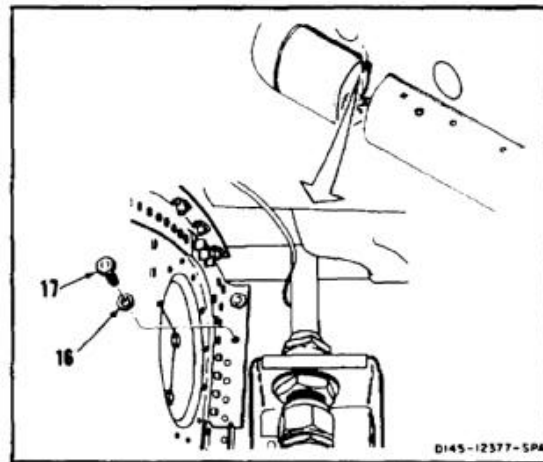
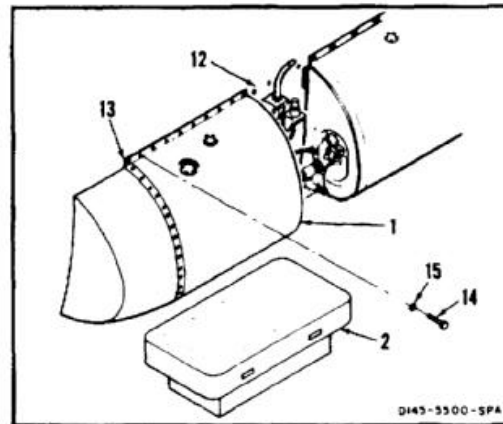

- 13.1. Install two washers (18) and bolts (19).
14. Install cabin side acoustic blanket (20) (Task 2-108).

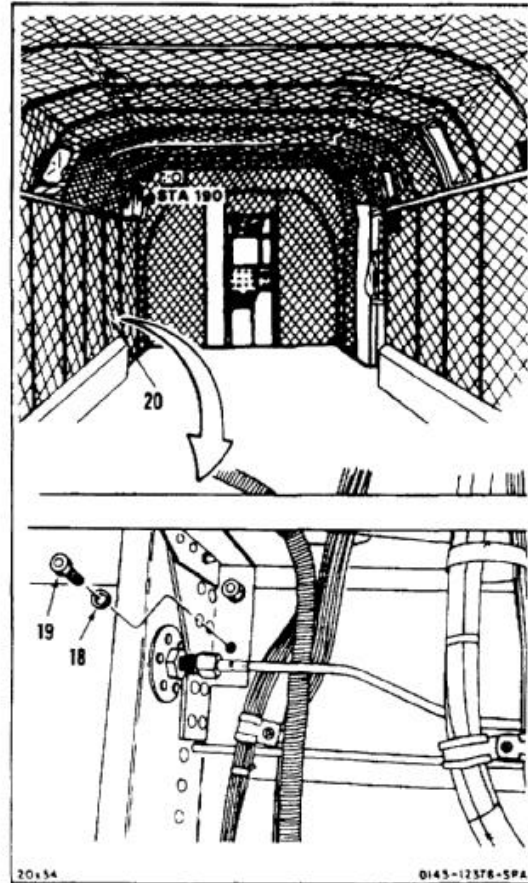

15. Install forward landing gear outboard wheel (Task 3-12).
16. Remove jack from forward fuselage jack pad (Task 1-22).
17. Install 54 screws (21) and washers (22) in splice plate (23).

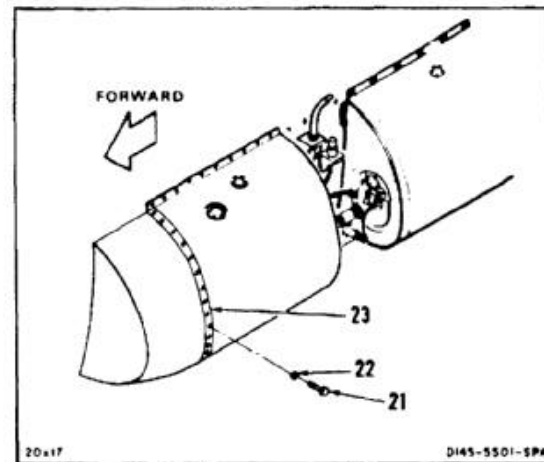

18. Remove barrier material and tape from flange of fitting (24) and adapter (25). Remove tape residue. Use dry cleaning solvent (E162). Wear goggles to protect eyes. Wear gloves (E184.1).

NOTE

Tube (28) is not symmetrical. Make sure that the upper nut at the landing gear mount remains accessible when installing the tube.

19. Position two gaskets (26 and 27) and tube (28). Slide adapter (25) forward to position gaskets and tube.
20. Install eight bolts (29), washers (30), and nuts (31).



Do not allow nipple or elbows to turn when connecting fuel hoses to aft access door. Otherwise, access door fittings can fail and cause blockage.

21. Remove plug from hose (32) and cap from nipple (33). Hold nipple with wrench and connect hose to nipple.



If the conical seal is not installed, fuel leakage will occur.

22. Remove plug from hose (34) and cap from elbow (35). Install conical seal (34.1) in hose (34) fitting. Hold elbow with wrench and connect hose to elbow.
23. Remove plug from hose (36) and cap from elbow (37). Hold elbow with wrench and connect hose to elbow.
24. Connect electrical connector (38).
- 24.1. Connect hook (38.1) to the lanyard on electrical connector (38) and bracket (38.2).

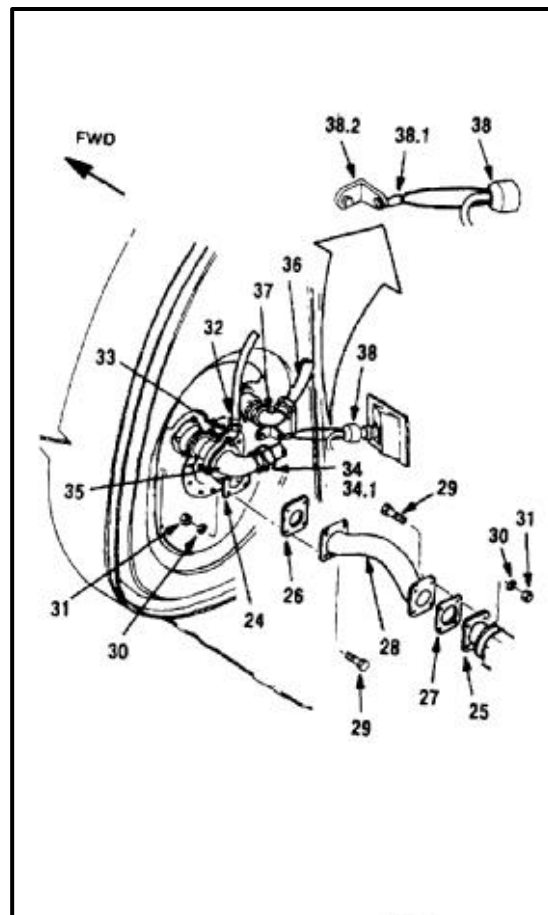

INSPECT***FOLLOW-ON MAINTENANCE:***

- Perform vent system pressure test (Task 10-117) and flow test (Task 10-118) on affected tank.
- Perform test of pressure refueling system (Task 10-119) and fuel feed system (Task 10-120).
- Refuel helicopter (Task 1-51).
- Bleed fuel system (Task 10-121).
- Perform operational check of affected fuel system (TM 55-1520-240-T).
- Inspect for leaks (Task 10-4).
- Install forward landing gear access panel (Task 2-179 or 2-181).

END OF TASK

INITIAL SETUP

Applicable Configurations:

All

Tools:

Aircraft Mechanic's Tool Kit, NSN 5180-00-323-4692
 Nitrogen Supply With Regulator (Preferred) or Low Pressure Air Source (0-120 psig dry/filtered)
 Air Regulator Assembly, NSN 4940-00-200-2096
 Hose, Air, General Purpose, NSN 4720-00-289-3429
 Vent Valve, NSN 4820-00-720-4488
 Shutoff Valve, NSN 4820-01-015-6690
 Low Pressure Air Gage, 0-15 psig, NSN 6685-00-729-4434
 Stopwatch/Timer
 Plug, MITPK, 114200
 Hose Clamps, NSN 4730-00-965-7503
 Tee, Pipe, NSN 4730-00-278-3990
 Adapter, Straight, Pipe to Hose, NSN 4730-00-287-1876
 Closure Plate (E-17)
 Torque Wrench, 30 to 150 Inch-pounds

Materials:

Soap (E353)
 Brush (E85)
 Petrolatum (E274)

Parts:

Packings
 Gaskets

Personnel Required:

Medium Helicopter Repairer
 Inspector

References:

Task 8-81
 Task 8-82
 Task 10-26

Equipment Condition:

Battery Disconnected (Task 1-39)
 Electrical Power Off
 Helicopter Grounded (Task 1-29)
 Fuel Tanks Defueled on Affected Side (Task 10-34 or 10-35)
 Forward Landing Gear Access Door Open (Task 2-2)

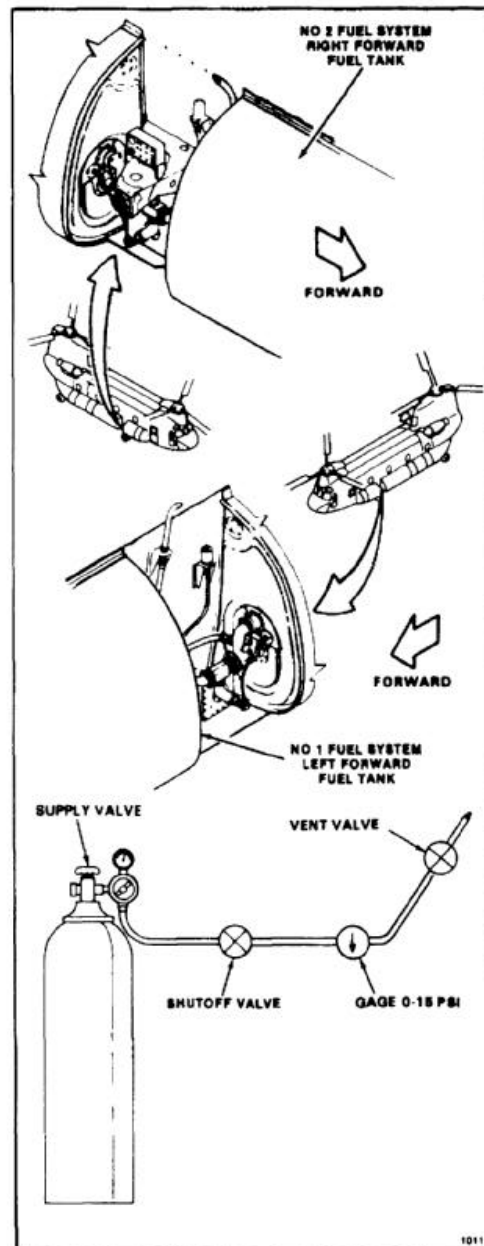

General Safety Instructions:**WARNING**

All regulations and instructions for handling fuels shall be strictly observed.

NOTE

Procedure is same to test No. 1 or No. 2 fuel system forward fuel tank. No. 1 forward tank is shown here.

1. Remove aft drain valve (1) and two packings (2 and 3). Install plug in port (4).

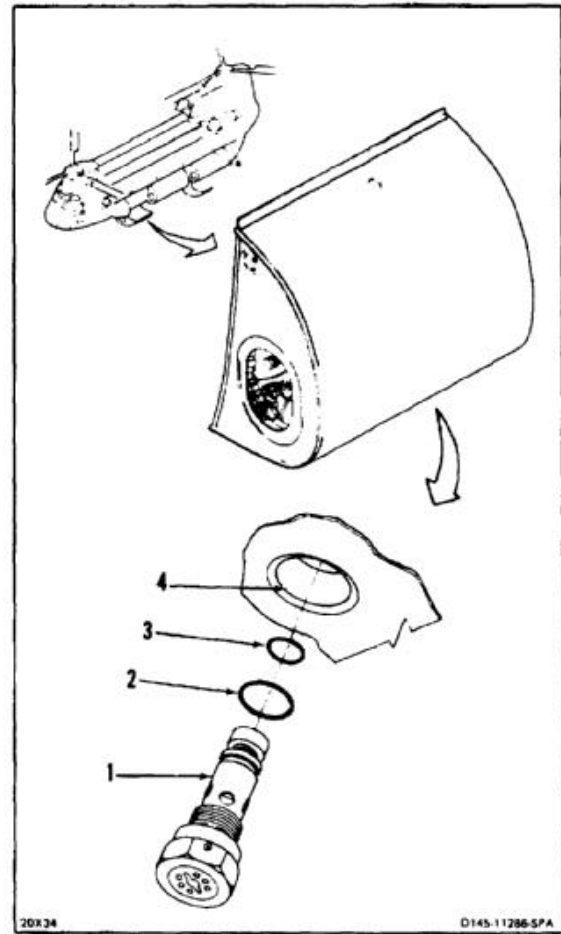
**CAUTION**

Do not allow elbows or fittings to turn when disconnecting hoses from access panel. Otherwise, fittings can fail and cause blockage.

2. Hold elbow (5) with wrench and disconnect hose (6). Remove conical seal (6.1) from hose (6) fitting. Plug hose and cap elbow.
3. Hold fitting (7) with wrench and disconnect hose (8). Plug hose (8).
4. Remove eight nuts (9), washers (10), and bolts (11). Remove tube (12) and two gaskets (13). Install closure plate (14) and gasket on adapter (15). Use four bolts, washers, and nuts.

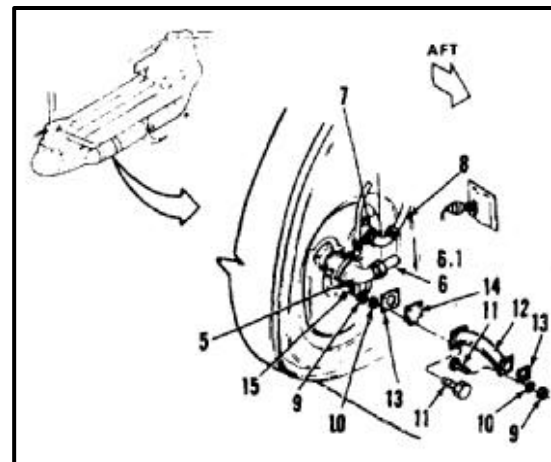

5. Make sure valves (16 and 17) are closed. Connect test setup to fitting (7).



Structural damage to aircraft may occur if more than **4.0 psi** is applied.

6. Open valve (16) and apply **3.0 psi**. Close valve. Do not apply more than **4.0 psi**.
7. Wait **15 minutes**. Check gage (18). If gage indicates **3.0 psi**, go to step 16. If gage indicates less than **3.0 psi**, go to step 8.

CHECK FOR LEAKS OUTSIDE TANK

8. Check for leaks as follows:
 - a. Check test setup upstream and downstream of valves (16 and 17) and gage (18). Use mixture of soap (E353) and water and brush (E85). Allow system to remain under measure for **15 minutes**. If bubbles grow in size, connection is leaking. Tighten leaking connections or replace packings as needed. Also check all joints, seams, and cast components. If leak is found, repeat steps 6 and 7.
 - b. Check three fittings (19). Apply soap mixture as in step 8a. Secure fittings or replace packings if needed. If leak is found, repeat steps 6 and 7.
 - c. Check aft access door (20). Apply soap mixture as in step 8a. Secure access door or replace gaskets, if needed. If leak is found, repeat steps 6 and 7.

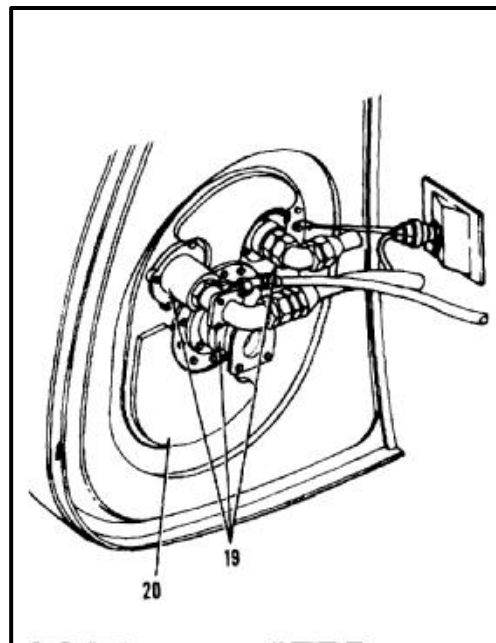
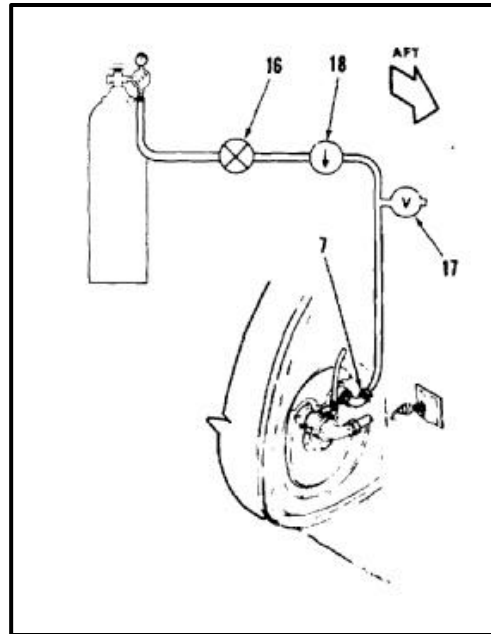

- d. Check flange (21). Apply soap mixture as in step 8a. Secure flange or replace packing, if needed. If leak is found, repeat steps 6 and 7.
- e. Check filler adapter (24). Apply soap mixture as in step 8a. Secure filler adapter or replace packing, if needed.
- f. Check sump drain (25). Apply soap mixture as in step 8a. Secure drain or replace packings, if necessary. If leak is found, repeat steps 6 and 7.
- g. Check aft closure plate (22) at end of tank (23). Apply soap mixture as in step 8a. Secure closure plates or replace packings, if needed. If leak is found, repeat steps 6 and 7.
- h. If no leakage is found in steps 8a thru g, go to step 16. If leaks are still found, go to step 9.

CHECK FOR LEAKS INSIDE TANK

9. Remove probe (21) and gasket (Task 8-81). Check inside of flange (21.1). Check underside of gasket and sealing surfaces. Install probe (Task 8-82). Repeat steps 6 and 7.

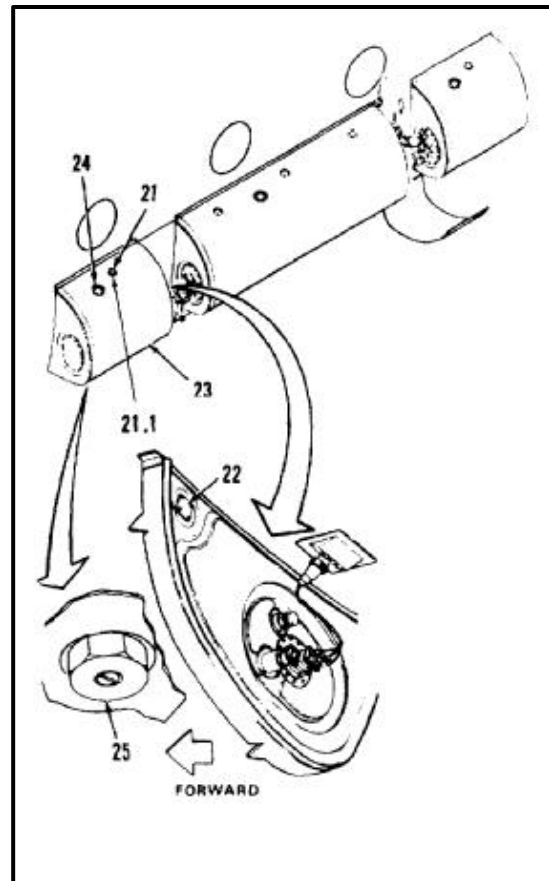

10. Check inside of filler adapter (24) as follows:
 - a. Remove six bolts (26) and washers (27), adapter (28), and gasket (29).
 - b. Remove three screws (30). Remove packing (31).
 - c. Check sealing surfaces between cell (32) and pod (33).
 - d. Coat packing (31) with petrolatum (E274). Install packing carefully in annular groove of cell flange (34). Make sure packing is not disturbed during positioning of fuel cell (32) in pod (33).
 - e. Align hole (35) in cell (32) with hole (36) in pod (33). Install three screws (30).
 - f. Position gasket (29) and filler adapter assembly (28). Install six bolts (26) and washers (27). Torque bolts to **60 to 80 inch-pounds**.
 - g. Repeat steps 6 and 7.

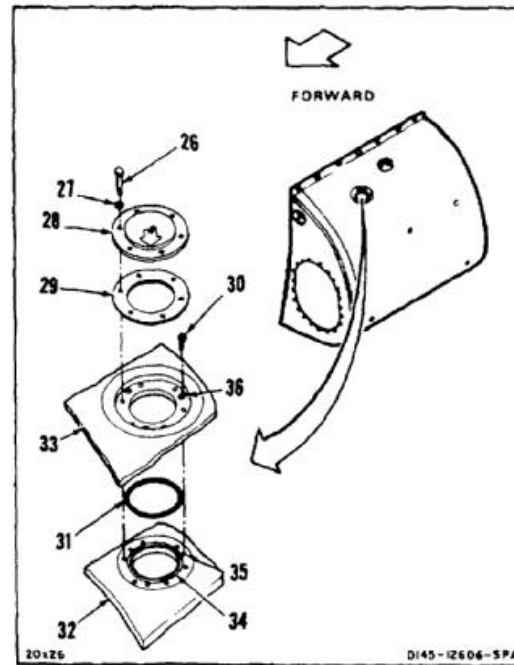

10-27 TEST FORWARD FUEL TANK AFTER INSTALLATION (Continued)**10-27**

11. Remove 54 screws (37) and washers (38) from splice plate (39). Remove splice plate.
12. Lower forward tank (23) (Task 10-26).
13. Check inside of forward access door (20) as follows:
 - a. Remove 30 bolts (40) and washers (41).
 - b. Remove door (20) and gasket (42).
 - c. Remove four screws (43). Remove gasket (44).
 - d. Lightly smear both sides of gasket (44) with petrolatum (E274).
 - e. Position gasket (44) between fuel pod (33) and fuel cell (32) at end of fuel pod.
 - f. Align fuel pod (33), gasket (44) and fuel cell (32). Install four screws (43).
 - g. Install access door (20) (Task 10-70).
 - h. Repeat steps 6 and 7.
14. Check inside of forward closure plate (22) as follows:
 - a. Remove four bolts (45), washers (46), and packing (47).
 - b. Remove two screws (48) and packing (49).
 - c. Coat packing (49) with petrolatum (E274). Install packing carefully in annular groove of flange (50). Make sure packing is not disturbed during positioning of fuel cell (32) in pod (33).
 - d. Align holes (51) with holes (52). Install two screws (48).
 - e. Coat packing (47) with petrolatum (E274). Install packing carefully in annular groove of cell flange (53). Position closure plate (22) on tank pod (33).
 - f. Install four bolts (45) and washers (46). Torque bolts to **60 to 80 inch-pounds**.
 - g. Repeat steps 6 and 7.
15. Repeat steps 13 and 14 at aft end of tank (23).

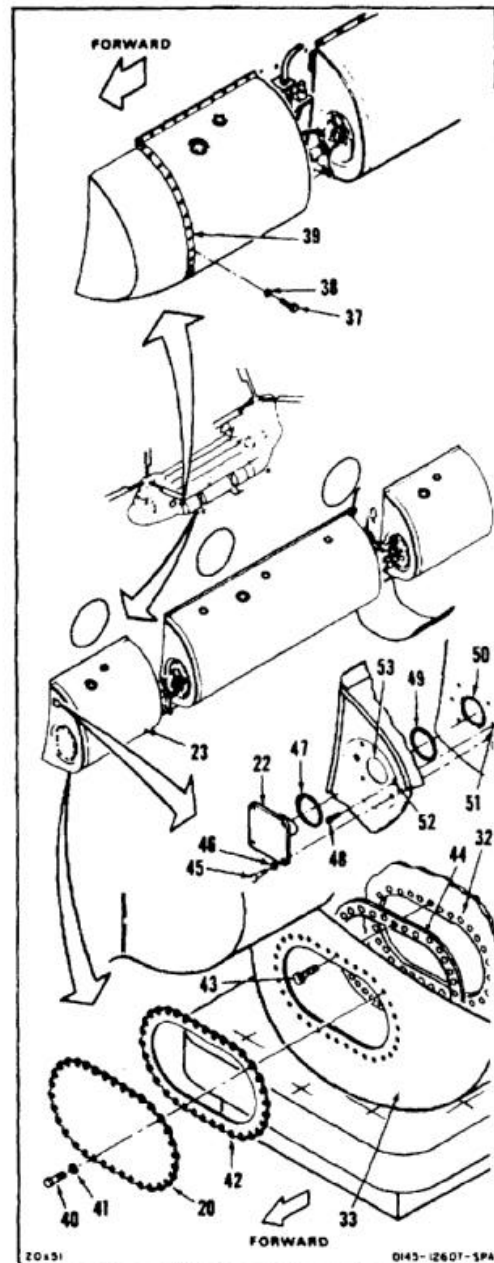

16. Open vent valve (17) and reduce pressure to **0 psi**.
17. Disconnect test setup from fitting (7).

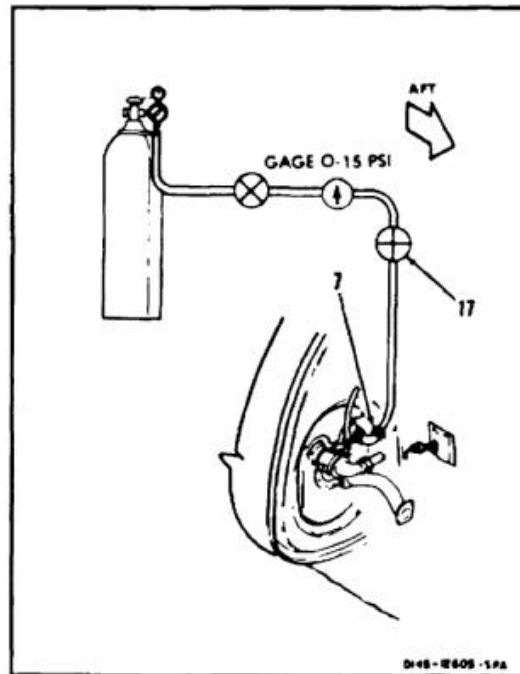

CAUTION

Do not allow elbow or fittings to turn when connecting hoses to aft access panel. Otherwise, fittings can fail and cause blockage.

18. Remove plug from hose (8). Hold fitting (7) with wrench and connect hose to fitting.
19. Remove plug from hose (6) and cap from elbow (5). Install conical seal (6.1) in hose (6) fitting. Hold elbow with wrench and connect hose to elbow.
20. Remove four bolts (11), washers (10), and nuts (9). Remove closure plate (14) and gasket (13).

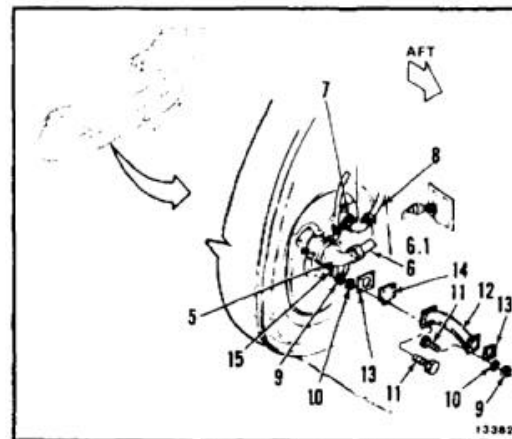

NOTE

Tube (12) is not symmetrical. Make sure that the upper nut on the landing gear mount remains accessible when installing the tube.

21. Install tube (12) and two gaskets (13). Use eight bolts (11), washers (10), and nuts (9).

22. Remove plug from port (4). Install packings (2 and 3) on drain valve (1). Install valve in port.

FOLLOW-ON MAINTENANCE:

Perform vent system pressure test (Task 10-117) and flow test (Task 10-118) on affected tank.
 Perform test of pressure refueling system (Task 10-119) and fuel feed system (Task 10-120).
 Refuel helicopter (Task 1-51).
 Bleed fuel system (Task 10-121).
 Perform operational check of affected fuel system (TM 55-1520-240-T).

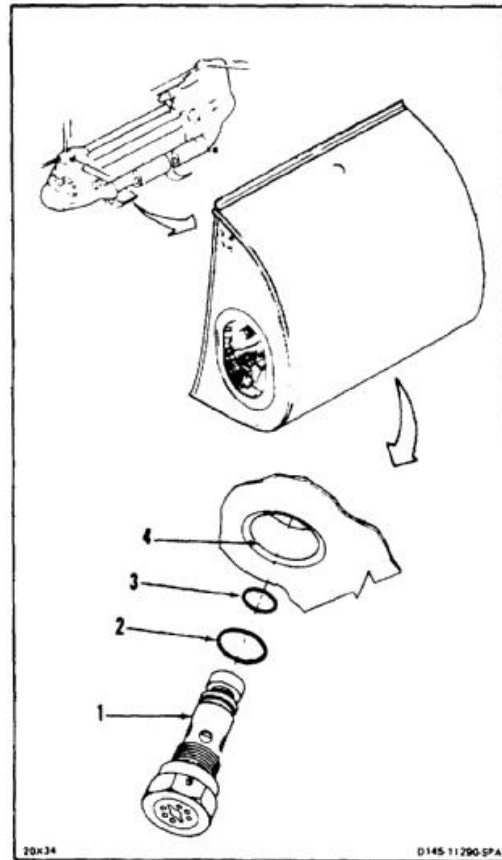

END OF TASK

INITIAL SETUP

Applicable Configurations:

All

Tools:

Aircraft Mechanic's Tool Kit, NSN 5180-00-323-4692
 Padded Support
 Wrench, Open End, 1-1/2 Inch
 Wrench, Open End, 1-7/8 Inch
 Strap Wrench
 Grounded Container, 2 Quart or Equivalent

Materials:

Cloths (E135)
 Penetrating Lubricant (E236)
 Barrier Material (E80)
 Tape (E388)

Personnel Required:

Medium Helicopter Repairer (2)

Equipment Condition:

Battery Disconnected (Task 1-39)
 Electrical Power Off
 Helicopter Grounded (Task 1-29)
 Fuel Tank Defueled (Task 10-34 or 10-35)
 Fuel Pod Vent Fairing Removed (Task 10-63)
 Aft Intertank Pod Panel Removed (Task 2-185)
 Aft Pod Panel Removed (Task 2-185)
 Fuel Tank Purged (Task 10-2)

General Safety Instructions:**WARNING**

All regulations and instructions
 for handling fuels shall be strictly
 observed.

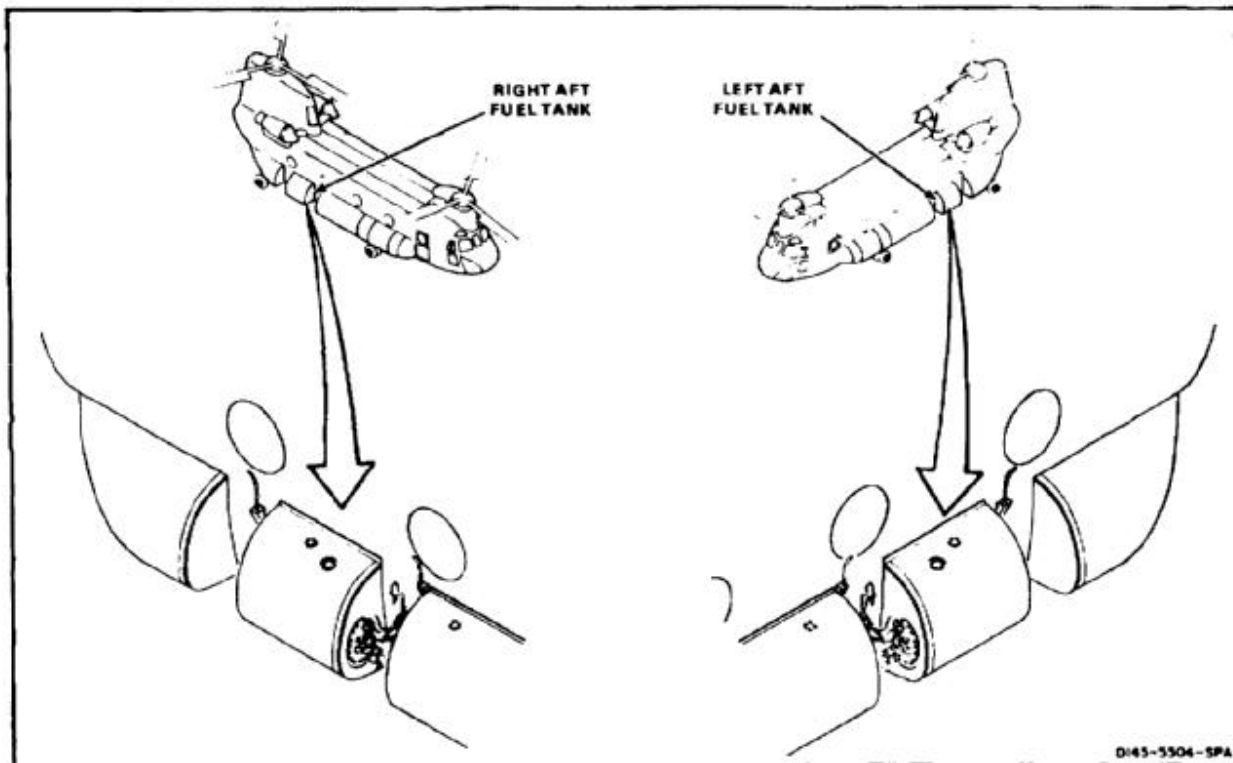

NOTE

Procedure is same to remove aft fuel tank in No. 1 or No. 2 fuel system. Removal of No. 1 (left) tank is shown here.

LOWER FUEL TANK ON HINGES

1. Disconnect electrical connector (1).
- 1.1. Disconnect hook (1.1) from cable (1.2).
2. Remove four nuts (2), washers (3), and bolts (4).
3. Slide adapter (5) forward on elbow (6). Remove gasket (7). Catch spilled fuel in grounded container.



Do not allow nipple or fittings to turn when disconnecting fuel lines from forward or aft access panel of tank. Otherwise, access door fittings can fail and cause blockage.

4. Hold nipple (8) with strap wrench and disconnect hose (9). Cap nipple and plug hose.
5. Hold breakaway fitting (10) with strap wrench and disconnect hoses (11 and 12). Remove conical seals (11.1 and 12.1) from hose fittings. Cap fitting and plug hoses.

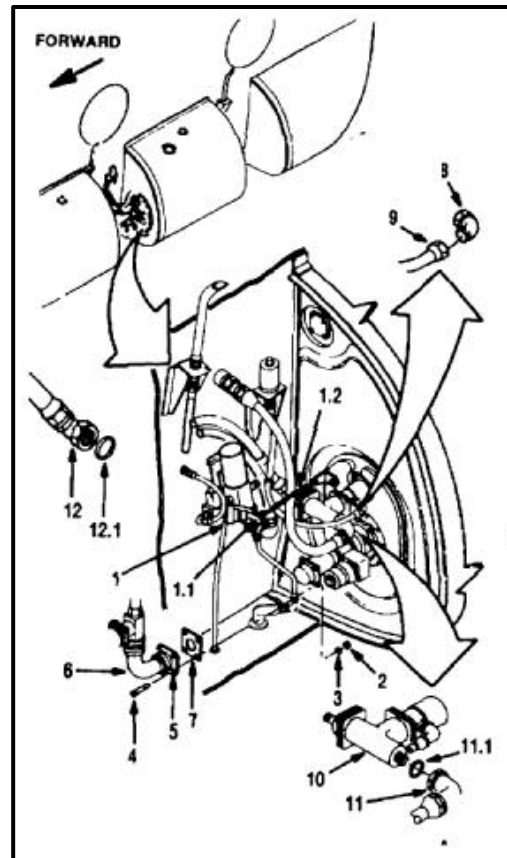

6. Hold fitting (13) with wrench and disconnect hose (14). Cap fitting and plug hose.
7. Position padded support (15) at side of tank (16). Top of support should be approximately **24 inches** below bottom of fuselage.
8. With aid from helper, support tank (16). Remove 17 bolts (17) and washers (18).
9. Remove four bolts (19) and washers (20).
10. Lower tank (16) on hinge (21) onto padded support (15).
11. Cover holes in flange of fitting (22) and adapter (5) of elbow (6). Use barrier material (E80) and tape (E388).

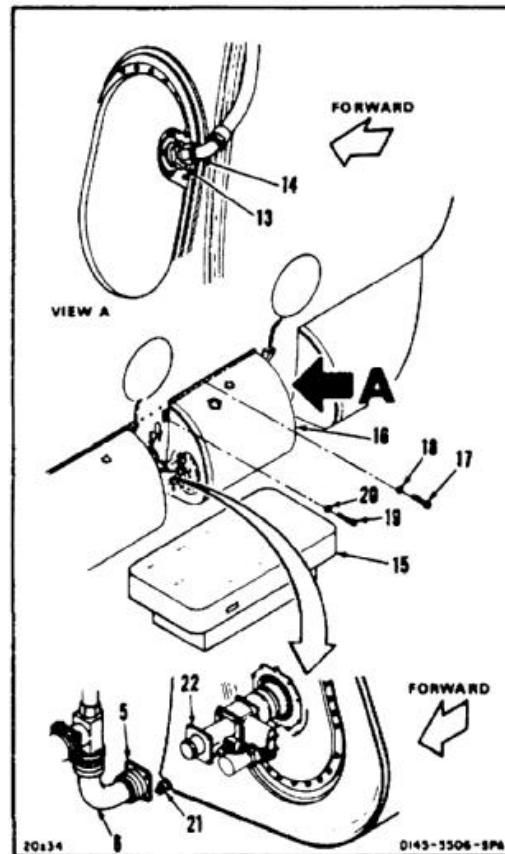

REMOVE FUEL TANK

12. Remove two straps (23) securing sleeves (24).
13. Disconnect two cable plugs (25).
14. Spray hinge (21) with penetrating lubricant (E236).
15. Remove lockwire (26).
16. Remove hinge pins (27 and 28).
17. Remove tank (16) and support (15).
18. Clean up spilled fuel. Use cloths (E135).

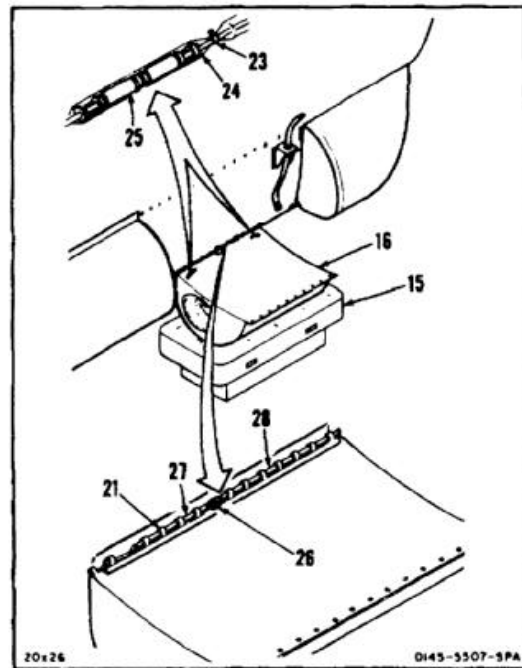
**FOLLOW-ON MAINTENANCE:**

None

END OF TASK

INITIAL SETUP

Applicable Configurations:

All

Tools:

Aircraft Mechanic's Tool Kit, NSN 5180-00-323-4692

Materials:

None

Personnel Required:

Medium Helicopter Repairer

Equipment Condition:

Aft Fuel Tank Removed (Task 10-28)
 Fuel Quantity Indicating System Tank Unit Removed
 (Task 8-81)
 Aft Fuel Tank Boost Pump Removed (Task 10-79)
 Aft Tank Fuel Lines and Electrical Wiring Removed
 (Task 10-77)
 Aft Fuel Tank Vent Assembly Removed (Task 10-65)
 Fuel Level Control Valve and Mounting Bracket
 Removed (Task 10-59)
 Tank Drain Valves Removed (Task 10-39)
 Aft Fuel Tank Vent Valve Removed (Task 10-83)

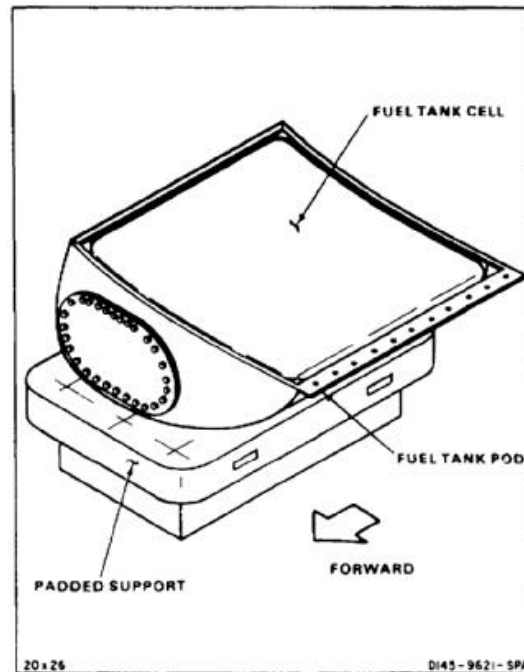
**General Safety Instructions:****WARNING**

All regulations and instructions for handling fuel shall be strictly observed.

CAUTION

Do not puncture or scratch lining of fuel tank. If lining is broken, fuel penetrates and activates self-sealing layers. Activated layers swell and trap fuel. Activated green spongy material also contaminates fuel system. This makes it necessary to replace fuel tank and flush fuel system.

NOTE

Procedure is same to remove cell from No. 1 or No. 2 aft fuel tank. Removal of No. 1 (left) cell is shown here.

REMOVE BOOST PUMP BRACKET

1. Remove four bolts (1) and washers (2).
2. Remove pump bracket (3).

NOTE

Four different types of aft fuel cells are used on the helicopter. Each is interchangeable and there may be washers or bushings installed between pump bracket and cell.

3. Remove four washers (4) or bushings (5) as necessary.
4. Remove four bolts (6) and washers (7).
5. Remove packing (8) between fuel pod (9) and fuel cell (10).

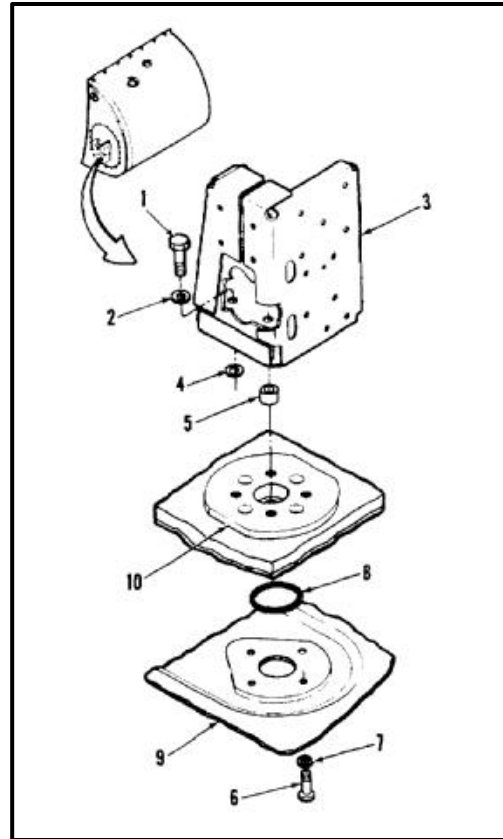

NOTE

Removal of closure plate and access hole gasket is same at both ends of tank.

6. Remove four screws (11) and washers (12). Remove closure plate (13) and packing (14).
7. Remove two screws (15) and packing (16).
8. Remove four screws (17). Remove gasket (18) between fuel pod (9) and fuel cell (10).

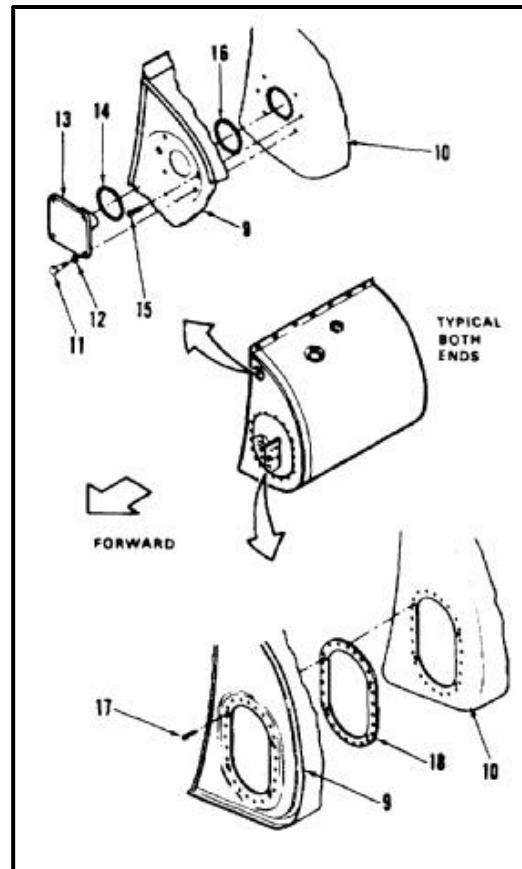

10-29 REMOVE AFT FUEL TANK CELL (Continued)**10-29**

9. Remove three screws (19). Separate fuel cell (10) from fuel pod (9). Remove gasket (20).
10. Remove six bolts (21) and washers (22).
11. Remove filler adapter assembly (23) and gasket (24).
12. Remove three screws (25). Separate fuel cell (10) from fuel pod (9). Remove packing (26).
13. Remove three bolts (27) and washers (28).

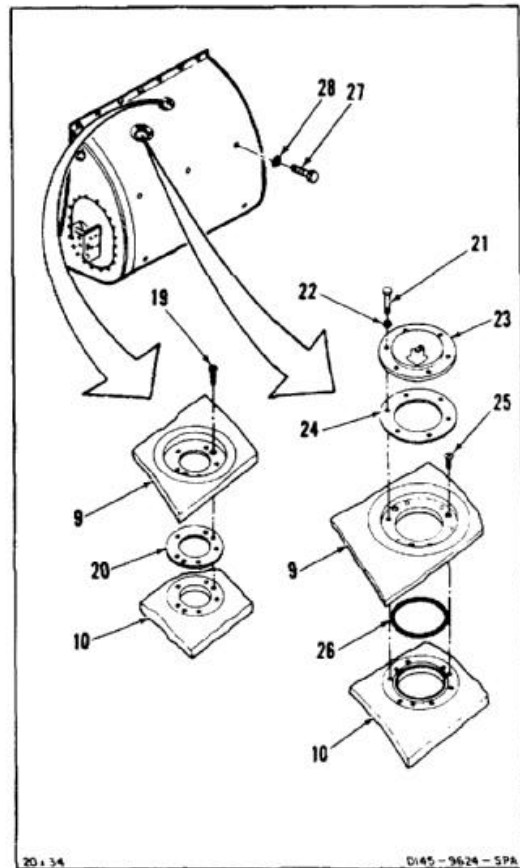

14. Carefully remove fuel cell (10) from pod structure (9).

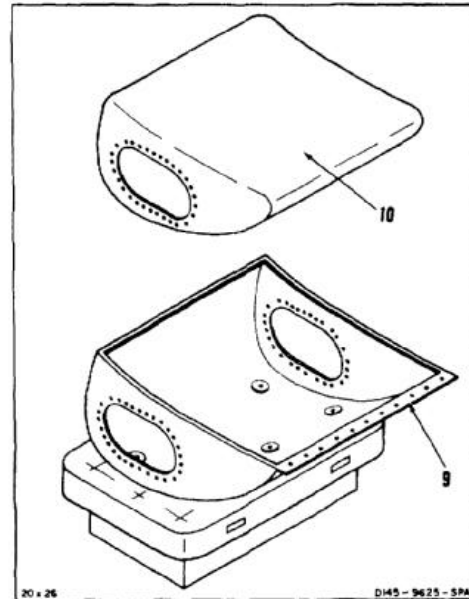

FOLLOW-ON MAINTENANCE:

None

END OF TASK

10-140

INITIAL SETUP

Applicable Configurations:

All

Tools:

Aircraft Mechanic's Tool Kit, NSN 5180-00-323-4692
Torque Wrench, 30 to 150 Inch-Pounds

Materials:

Petrolatum (E274)

Parts:

Packings
Gaskets

Personnel Required:

Medium Helicopter Repairer
Inspector

References:

Task 10-40
TM 55-1520-240-23P

General Safety Instructions:

Do not puncture or scratch lining of fuel cell. If lining is broken, fuel penetrates and activates self-sealing layers. Activated layers swell and trap fuel. Activated green spongy material also contaminates fuel system. This makes it necessary to replace fuel cell and flush fuel system.

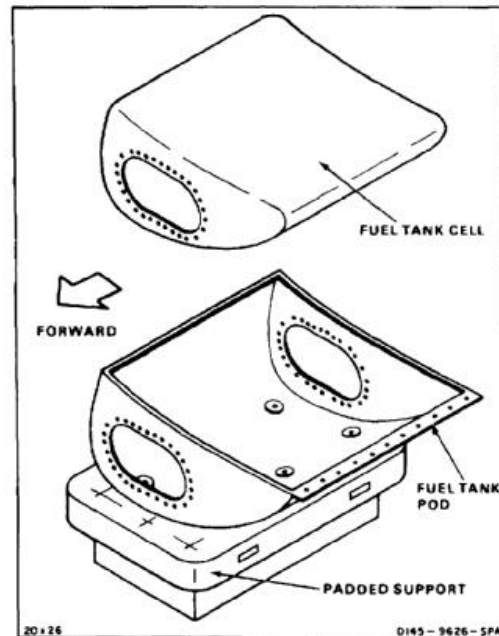

NOTE

Procedure is same to install cell in No. 1 or No. 2 fuel tank pod. Installation of No. 1 (left) cell is shown here.

NOTE

Before installing aft fuel tank check backboard for condition.

1. Make sure interior of fuel tank pod (1) is free of foreign material.
2. Position fuel cell (2) carefully in tank pod (1). Insert lower portion of cell in pod. Depress top portion of cell. Position it in and along top portion of tank pod.
3. Form cell (2) to fit contour of pod structure (1).
4. Install bolt (3) and washer (4). Do not tighten bolt at this time.
5. Install bolts (5 and 6) and washers (4). Do not tighten bolts at this time.
6. Tighten three bolts (3, 5 and 6) in this order.
7. Coat two packings (7) with petrolatum (E274). Install packings carefully in annular groove of flange (8) at each end of tank. Make sure that packings are not disturbed during positioning of fuel cell (2) in pod (1).
8. Align holes (9) in pod (1) with holes (10) in cell (2). Install eight bolts (11) and washers (12). Torque bolts to **60 to 80 inch-pounds**.

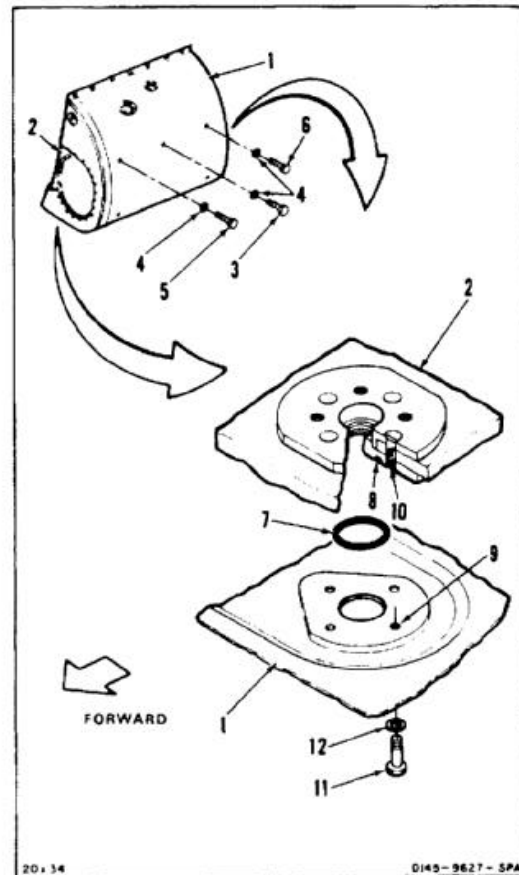

9. Coat two packings (13) with petrolatum (E274). Install packings carefully in annular groove of flange (14) at each end of cell (2). Make sure packings are not disturbed during positioning of fuel cell in pod (1).
10. Align holes (15) with holes (16). Install two screws (17) at each end of tank pod (1).
11. Coat two packings (18) with petrolatum (E274). Install packings carefully in annular groove of cell flange (19). Position closure plate (20) at each end of tank pod (1).
12. Install four bolts (21) and washers (22). Torque bolts to **60 to 80 inch-pounds**.
13. Coat packing (23) with petrolatum (E274). Install packing carefully in annular groove of cell flange (24). Make sure packing is not disturbed during positioning of fuel cell (2) in pod (1).
14. Align hole (25) in cell (2) with hole (26) in pod (1). Install three screws (27).
15. Position gasket (28) and filler adapter assembly (29). Install six bolts (30) and washers (31). Torque bolts to **60 to 80 inch-pounds**.
16. Position gasket (32) on flange (33) of fuel cell (2). Align holes (34) in fuel cell with holes (35) in pod (1). Install two screws (36).

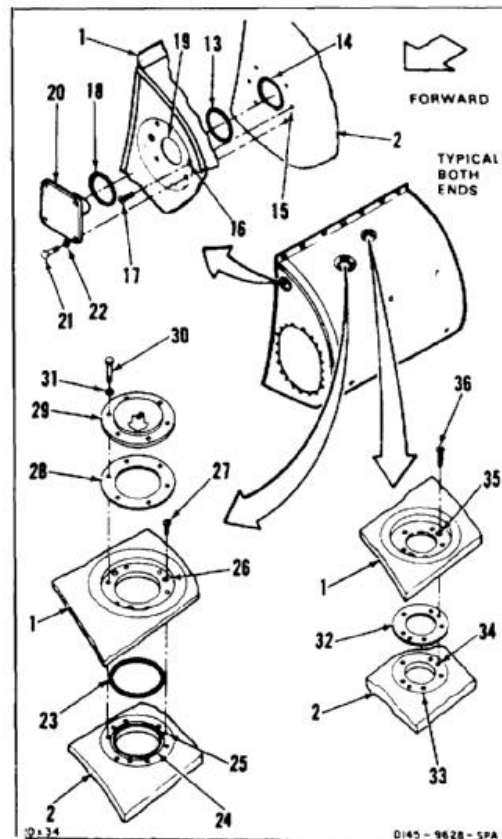

17. Lightly smear both sides of gasket (37) with petrolatum (E274).
18. Position gaskets (37) between fuel pod (1) and fuel cell (2) at both ends of fuel pod.
19. Align fuel pod (1), gaskets (37) and fuel cell (2). Install four screws (38) at each end of tank pod.

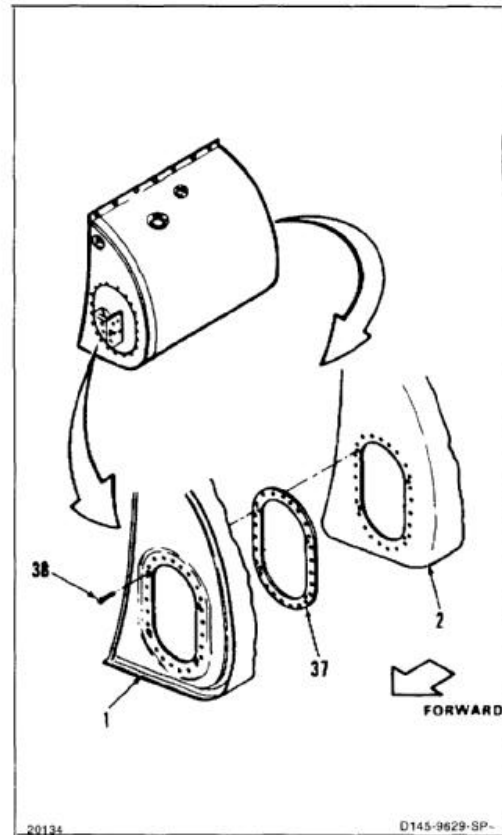

20. Install fuel tank drain valves (Task 10-40).

INSTALL BOOST PUMP BRACKET

NOTE

Four different types of aft fuel cells are used on the helicopter. Each is interchangeable and may require four washers/bushings between pump bracket and cell.

21. For fuel cell 145P4056-1 position four washers (39) on cell flange (4.0). For fuel cell 145P4056-2 or 414PS401-8 install four bushings (41) on cell flange (40).
22. Position pump bracket (42).
23. Install four bolts (43) and washers (44).

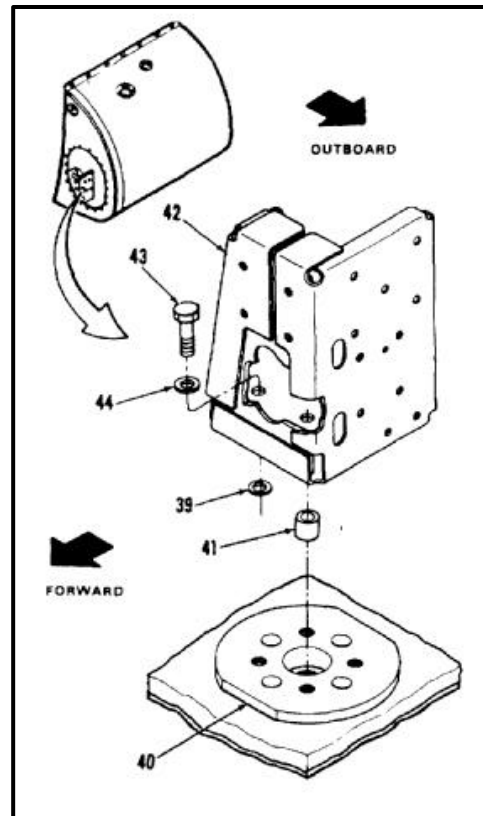

INSPECT

FOLLOW-ON MAINTENANCE:

- Install aft fuel tank vent valve (Task 10-84).
- Install fuel level control valve and mounting bracket (Task 10-60).
- Install auxiliary tank vent assembly (Task 10-66).
- Install aft tank fuel lines and electrical wiring (Task 10-78).
- Install fuel quantity indicating system tank unit (Task 8-82).
- Install aft tank boost pump (Task 10-80).
- Install aft fuel tank (Task 10-31).

END OF TASK

INITIAL SETUP

Applicable Configurations:

All

Tools:

Aircraft Mechanic's Tool Kit, NSN 5180-00-323-4692
 Wrench, Open End, 1-1/2 Inch
 Wrench, Open End, 1-7/8 Inch
 Strap Wrench

Materials:

Cloths (E135)
 Dry Cleaning Solvent (E162)
 Gloves (E186)
 Tiedown Straps (E375)
 Lockwire (E232)
 Lockwire (E231)
 Parting Agent (E307)
 Sealant (E336)
 Tongue Depressors (E424)

Parts:

Gaskets

Personnel Required:

Medium Helicopter Repairer (2)
 Inspector

References:

TM 55-1520-240-23P

General Safety Instructions:**WARNING**

All regulations and instructions for handling fuels shall be strictly observed.

WARNING

Dry cleaning solvent (E162) is flammable and toxic. It can irritate skin and cause burns. Use only in well-ventilated area, away from heat and open flame. In case of contact, immediately flush skin or eyes with water for at least **15 minutes**. Get medical attention for eyes.

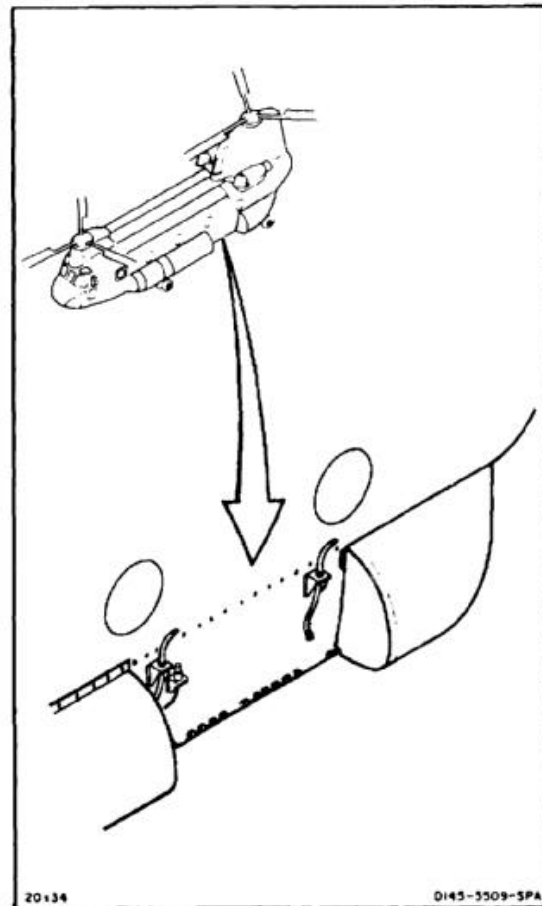
**WARNING**

Parting agent (E307) can form toxic vapors if exposed to flame. Use in well-ventilated area, away from open flame. In case of contact, immediately flush skin or eyes with water for at least **15 minutes**. Get medical attention for eyes.

WARNING

Sealant (E336) can irritate skin and cause burns. Avoid contact with skin, eyes, and clothing. In case of contact, immediately flush skin or eyes with water for at least **15 minutes**. Get medical attention for eyes.

NOTE

Procedure is same to install aft fuel tank in No. 1 or No. 2 fuel system. Installation of No. 1 (left) tank is shown here.

INSTALL FUEL TANK ON HINGES

1. With aid from helper, position tank (1) on padded support (2) at side of helicopter. Align fuselage hinge half (3) with tank hinge half (4).
2. Install hinge pin (5 and 6).
3. Install lockwire (7).
4. Connect two cable plugs (8).
5. Slide sleeve (9) over plugs (8) and tank sleeve (10). Secure sleeve with tiedown straps (E375) (11).

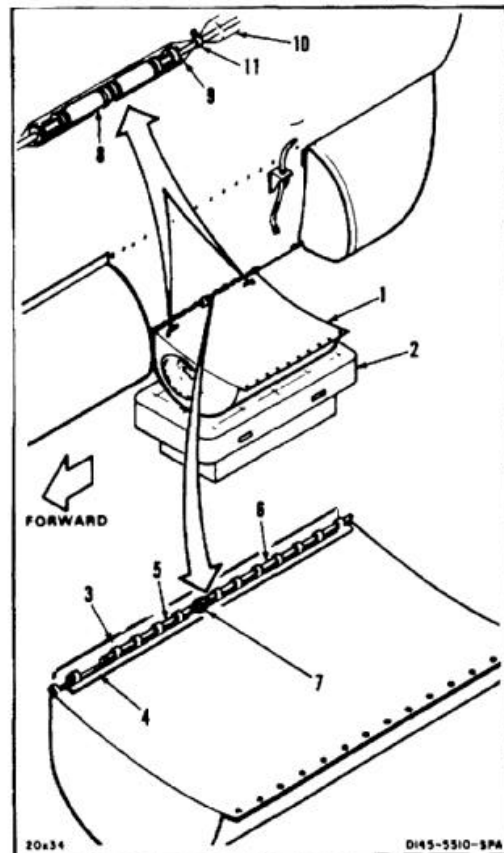

RAISE AND INSTALL FUEL TANK

6. Clean beam (12) and top edge (13) of tank (1). Use dry cleaning solvent (E162) and cloths (E135). Wear goggles to protect eyes. Wear gloves (E186).
7. Apply thin coat of parting agent (E307) along beam (12). Use tongue depressor (E424). Wear gloves (E186).
8. Apply coat of sealant (E336) on top inner edge of tank (13). Use tongue depressor (E424). Wear gloves (E186).
9. Remove barrier material and tape from flange of elbow (14) and flange of fitting (15). Clean faces of flanges. Use dry cleaning solvent (E162) and cloths (E135). Wear goggles to protect eyes. Wear gloves (E186).
10. With aid from helper, raise tank (1) to installed position and support tank.
11. Install 17 bolts (17) and washers (18). Apply sealant (E336) over head of bolts.
12. Apply a bead of parting agent (E307) and then sealant (E336) to top outside edge of tank (1) where tank meets skin of aircraft.
13. Remove padded support (2).
14. Install four bolts (18) and washers (19).

CAUTION

Do not allow fittings to turn when connecting fuel hoses to access door. Otherwise, fittings can fall and cause blockage.

15. Remove cap from fitting (20) and plug from hose (21). Connect hose.

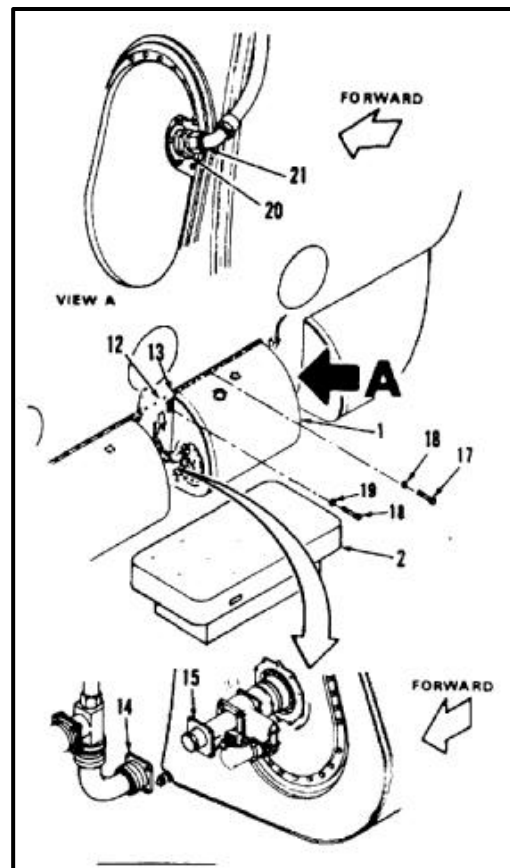

10-31 INSTALL AFT FUEL TANK (Continued)**10-31**

16. Remove caps from breakaway fitting (22) and plugs from hoses (23 and 24). Install conical seals (23.1 and 24.1) in hose fittings. Connect hoses.
17. Remove cap from nipple (25) and plug from hose (26). Connect hose.
18. Position gasket (27). Slide adapter (28) aft from elbow (14).
19. Install four bolts (29), washers (30), and nuts (31).
20. Connect electrical connector (32).
21. Connect hook (32.1) to the lanyard of electrical connector (32) and to cable (32.2).

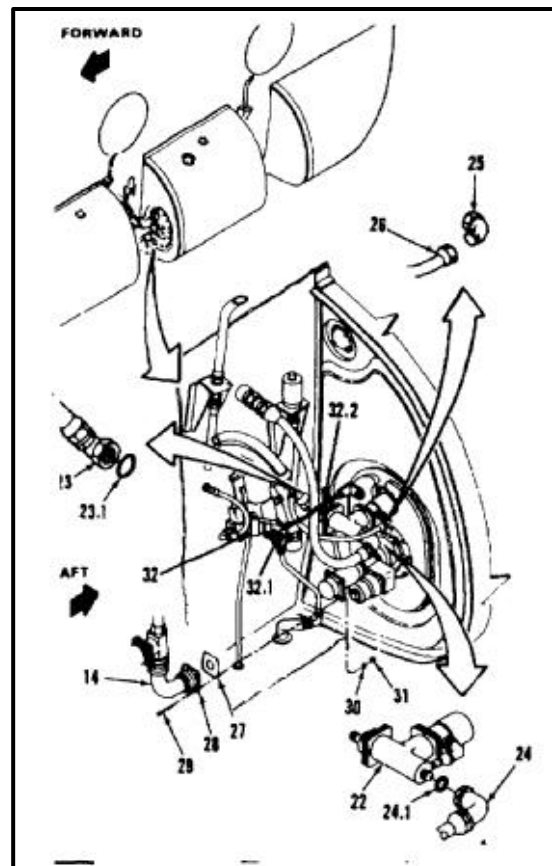
INSPECT**FOLLOW-ON MAINTENANCE:**

- Perform vent system pressure test (Task 10-117) and flow test (Task 10-118) on affected tank.
- Perform test of pressure refueling system (Task 10-119) and fuel feed system (Task 10-120).
- Refuel helicopter (Task 1-51).
- Bleed fuel system (Task 10-121).
- Perform operational check of affected fuel system (TM 55-1520-240-T).
- Inspect for leaks (Task 10-2).
- Install aft intertank pod panel (Task 2-188).
- Install aft pod panel (Task 2-188).
- Install fuel pod vent fairing (Task 10-64).

END OF TASK

INITIAL SETUP

Applicable Configurations:

All

Tools:

Aircraft Mechanic's Tool Kit, NSN 5180-00-323-4692
 Nitrogen Supply With Regulator (Preferred) or Low Pressure Air Source (0-12 psig dry or filtered)
 Air Regulator Assembly, NSN 4940-00-200-2096
 Hose, Air, General Purpose, NSN 4720-00-289-3429
 Vent Valve, NSN 4820-00-720-4488
 Shutoff Valve, NSN 4820-01-015-6690
 Low Pressure Air Gage, 0-15 psig, NSN 6685-00-729-4434
 Stopwatch/Timer
 Plug, MITPK, 114200
 Hose Clamps, NSN 4730-00-965-7503
 Tee, Pipe, NSN 4730-00-278-3990
 Adapter, Straight, Pipe to Hose, NSN 4730-00-287-1876
 Torque Wrench, 30 to 150 Inch-Pounds
 Grounded Container, 2 Quart or Equivalent

Materials:

Soap (E353)
 Brush (E85)
 Petrolatum (E274)

Parts:

Packings
 Gaskets

Personnel Required:

Medium Helicopter Repairer
 Inspector

References:

Task 8-81
 Task 8-82
 Task 10-39
 Task 10-40
 Task 10-79
 Task 10-80

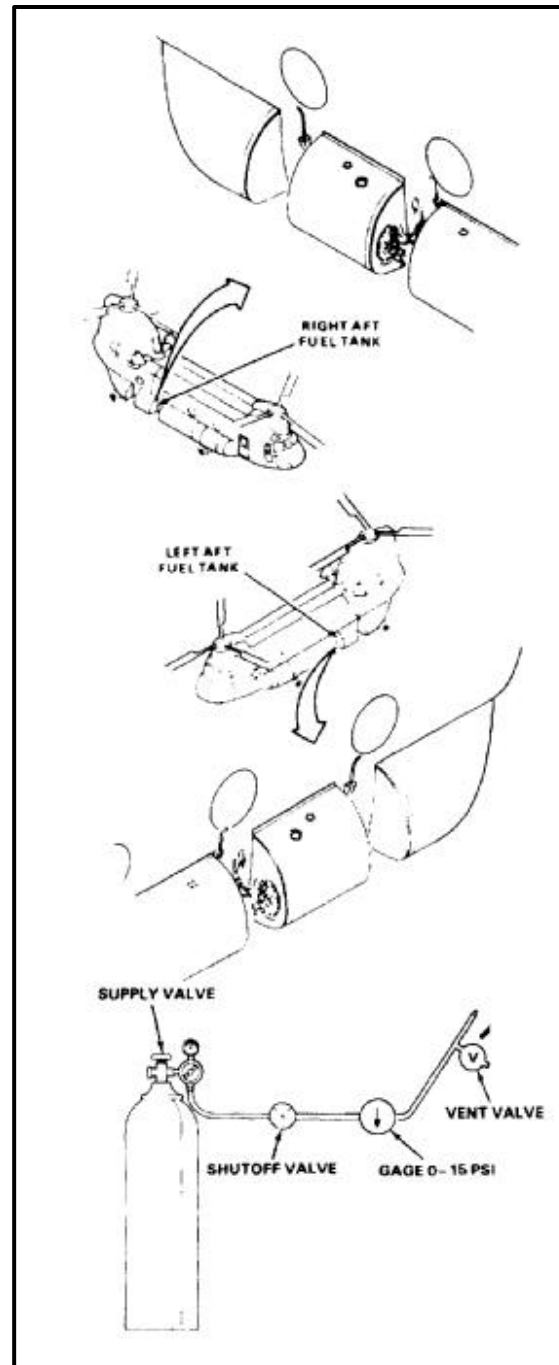

Equipment Condition:

Battery Disconnected (Task 1-39)
 Electrical Power Off
 Helicopter Grounded (Task 1-29)
 Fuel Tank Defueled on Affected Side (Task 10-34 or 10-35)
 Aft Intertank Pod Panel Lowered (Task 2-185)
 Aft Pod Panel Removed (Task 2-185)

General Safety Instructions:**WARNING**

All regulations and instructions for handling fuels shall be strictly observed.

NOTE

Procedure is same to test No. 1 or No. 2 fuel system aft fuel tank. No. 1 aft tank is shown here.

1. Remove aft drain valve (1) and two packings (2 and 3). Install plug in port (4).

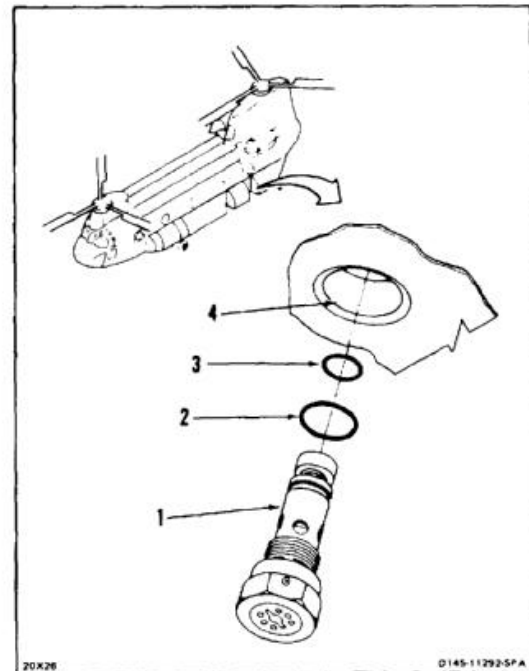
**CAUTION**

Do not allow nipple or fittings to turn when disconnecting fuel lines from forward or aft access panel of tank. Otherwise, access panel fittings can fall and cause fuel blockage.

2. Check that gate valve (5) is closed.
3. Hold breakaway fitting (6) with a strap wrench and disconnect hoses (7 and 8). Remove conical seals (7.1 and 8.1). Catch spilled fuel. Use grounded container. Cap fitting and plug hoses.

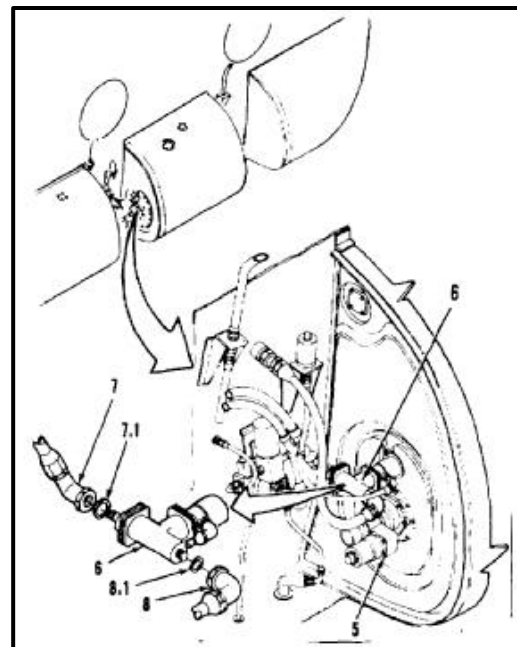

4. At aft end of tank (9), hold fitting (10) with wrench and disconnect hose (11). Plug hose.

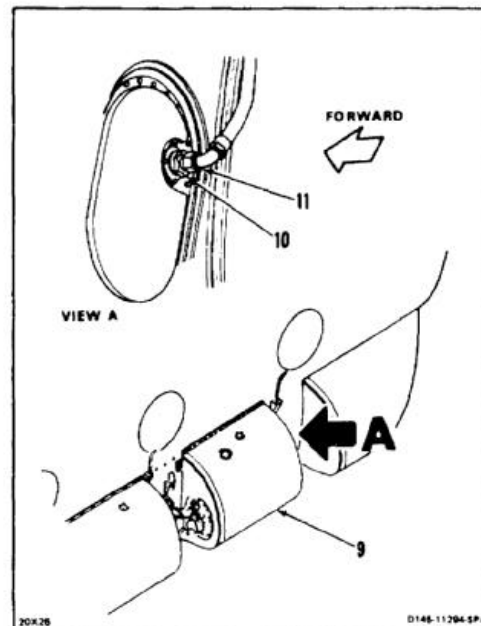

5. Make sure valve (12) is open and valve (13) is closed. Connect test setup to fitting (10).



Structural damage to aircraft may occur if more than **4.0 psi** is applied.

- 5.1. Open nitrogen or air supply source (13.1) and regulate pressure to **3.0 psi**. Do not apply more than **4.0 psi**.
6. Open valve (12) and allow pressure to stabilize at **3.0 psi**. Close valve. Do not apply more than **4.0 psi**.
7. Wait **15 minutes**. Check gage (14). If gage indicates **3.0 psi**, go to step 14. If gage indicates less than **3.0 psi**, go to step 8.

CHECK FOR LEAKS OUTSIDE OF TANK

8. Check for leaks as follows:
- Check test setup connections upstream and downstream of valves (12 and 13), and gage. Use mixture of soap (E353) and water, and brush (E85). Allow system to remain under pressure for **15 minutes**. If bubbles grow in size, connection is leaking. Tighten leaking connections or replace packings as needed. Also check all joints, seams, and cast components. If leak is found, repeat steps 6 and 7.

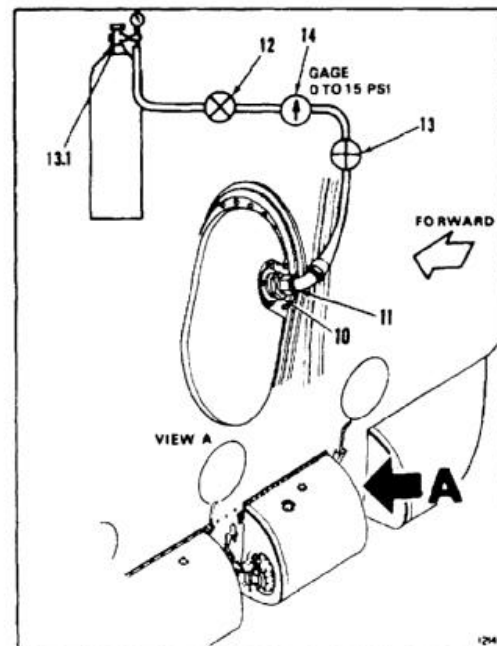

- b. Check two fittings (15) on forward end of tank (9). Apply soap mixture as in step 8a. Secure fittings or replace packings as needed. If leak is found, repeat steps 6 and 7.
- c. Check filler adapter (16). Apply soap mixture as in step 8a. Secure filler adapter or replace packings, if needed. If leak is found, repeat steps 6 and 7.
- d. Check flange (17). Apply soap mixture as in step 8a. Secure flange or replace packing, if needed. If leak is found, repeat steps 6 and 7.
- e. Check aft fitting (10). Apply soap mixture as in step 8a. Secure fitting or replace packing, if needed. If leak is found, repeat steps 6 and 7.
- f. Check two access doors (18). Apply soap mixture as in step 8a. Secure access doors or replace gasket, if needed. If leak is found, repeat steps 6 and 7.

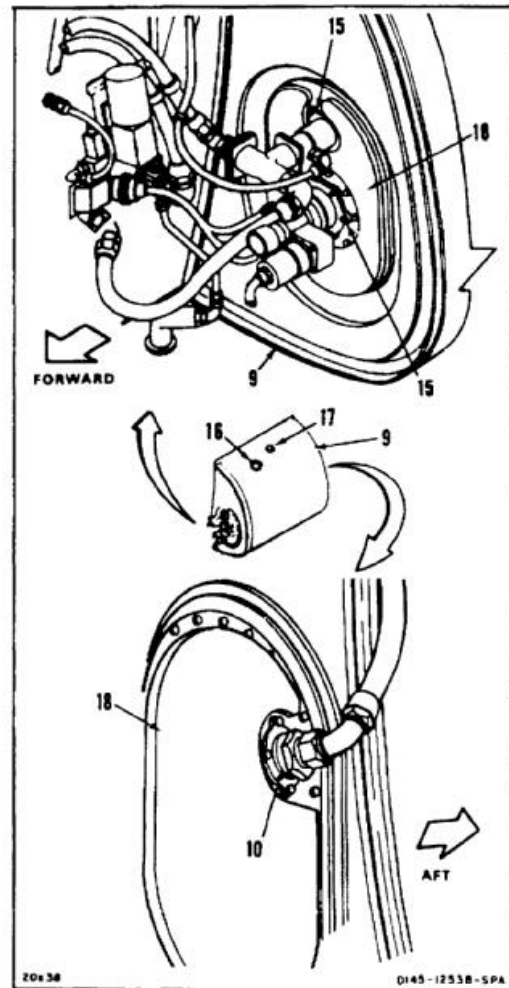

- g. Check closure plate (19) at each end of tank (9). Apply soap mixture as in step 8a. Secure plates or replace packings, if needed. If leak is found, repeat steps 6 and 7.
- h. Check pressure switch (20) and fittings on hose (21). Apply soap mixture as in step 8a. Secure valve or fittings, or replace packings, if needed. If leak is found, repeat steps 6 and 7.
- i. Check forward sump drain (22). Apply soap and water mixture as in step 8a. Secure drain or replace packings, if needed. If leak is found, repeat steps 6 and 7.
- j. If no leaks are found in steps 8a thru i, go to step 14. If leaks are found, go to step 9.

CHECK FOR LEAKS INSIDE TANK

- 9. Remove probe (22) and gasket (Task 8-81). Check inside of flange (22.1). Remove probe and gasket. Check underside of gasket and sealing surfaces. Install probe (Task 8-82). If leak is found, repeat steps 6 and 7.

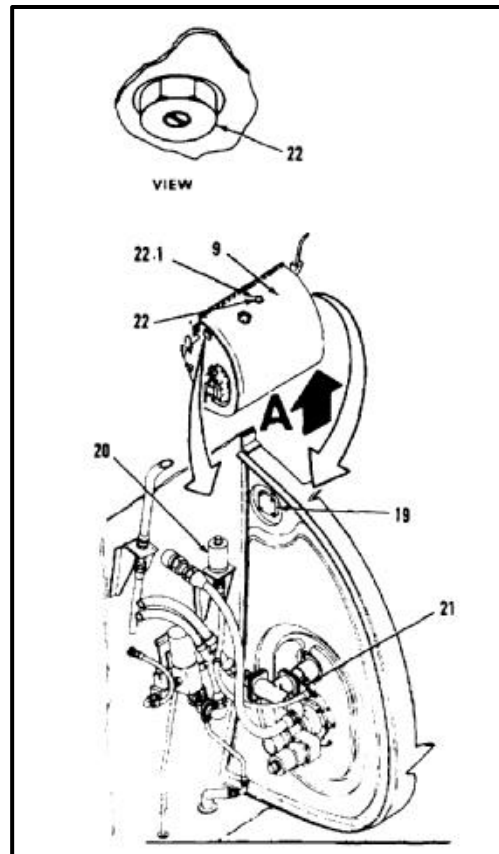

10. Check inside of filler adapter (25) as follows:
 - a. Remove six bolts (23) and washers (24), adapter (25), and gasket (26).
 - b. Remove three screws (27). Remove packing (28).
 - c. Check sealing surfaces between cell (29) and pod (30).
 - d. Coat packing (28) with petrolatum (E274). Install packing carefully in annular groove of cell flange (31). Make sure packing is not disturbed during positioning of fuel cell (29) in pod (30).
 - e. Align hole (32) in cell (29) with hole (33) in pod (30). Install three screws (27).
 - f. Position gasket (26) and filler adapter assembly (25). Install six bolts (23) and washers (24). Torque bolts to **60 to 80 inch-pounds**.
 - g. Repeat steps 6 and 7.

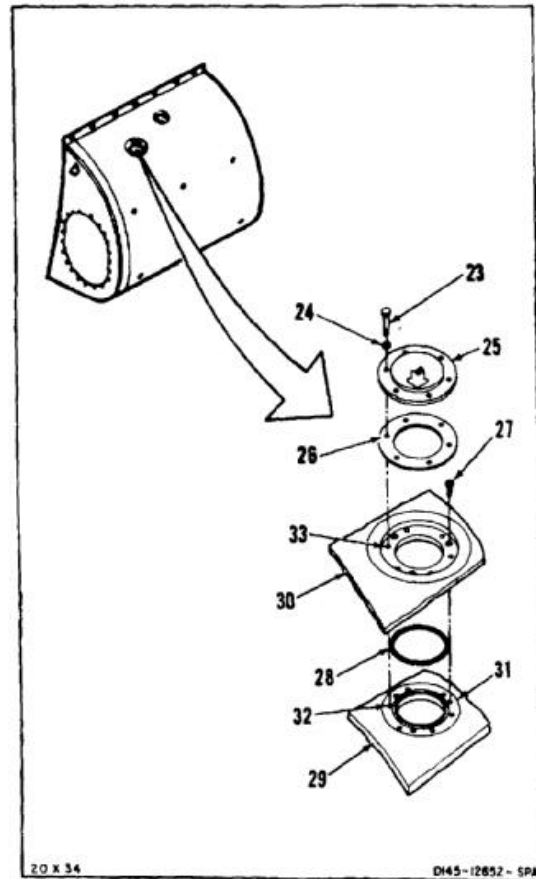

11. Check inside of forward closure plate (34) as follows:
 - a. Remove four bolts (35), washers (36), and packing (37).
 - b. Remove two screws (38) and packing (39).
 - c. Coat packing (39) with petrolatum (E274). Install packing carefully in annular groove of flange (40). Make sure packing is not disturbed during positioning of fuel cell (29) in pod (30).
 - d. Align holes (41) with holes (42). Install two screws (38).
 - e. Coat packing (37) with petrolatum (E274). Install packing carefully in annular groove of cell flange (40). Position closure plate (34) on tank pod (30).
 - f. Install four bolts (35) and washers (36). Torque bolts to **60 to 80 inch-pounds**.
 - g. Repeat steps 6 and 7.
12. Check inside of forward access door (18).
 - a. Remove access door (18) (Task 10-79).
 - b. Remove four screws (43). Remove gasket (44).
 - c. Lightly smear both sides of gasket (44) with petrolatum (E274).
 - d. Position gasket between pod (30) and cell (29).
 - e. Align pod (30), gasket (44), and cell (29). Install four screws (43).
 - f. Install access door (18) (Task 10-80).
 - g. Repeat steps 6 and 7.
13. Repeat steps 11 and 12 at aft end of tank (9).

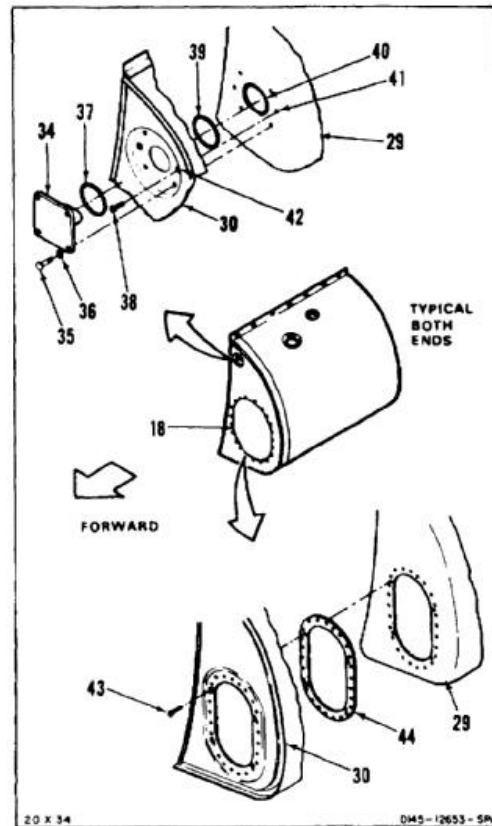

14. Open vent valve (13) and reduce pressure to **0 psi** close valve.
15. Disconnect test setup from fitting (10).

CAUTION

Do not allow nipple of fittings to turn when disconnecting fuel lines from forward or aft access panel of tank. Otherwise, access panel fittings can fall and cause fuel blockage.

16. Remove plug from hose (11). Hold fittings (10) with wrench and connect hose.

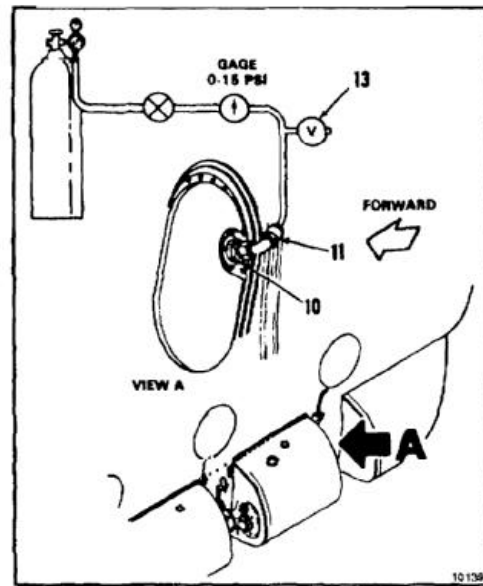

17. Remove caps from breakaway fitting (6) and plugs from hoses (7 and 8). Install conical seals (7.1 and 8.1) in hose fittings. Connect hoses.

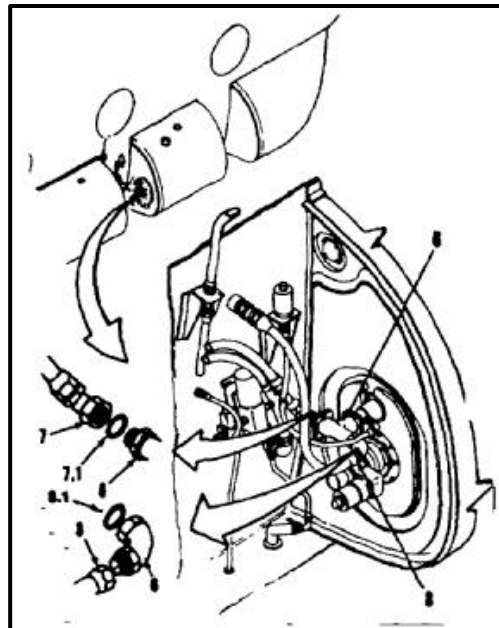

18. Remove plug from port (4). Install two serviceable packings (2 and 3) on valve (1). Install valve in port.

INSPECT**FOLLOW-ON MAINTENANCE:**

Perform vent system pressure test (Task 10-117) and flow test (Task 10-118) on affected tank.
Perform test of pressure refueling system (Task 10-119) and fuel feed system (Task 10-120).
Install aft pod panel (Task 2-188).
Raise aft intertank pod panel (Task 2-188).
Refuel helicopter (Task 1-51).
Bleed fuel system (Task 10-121).
Perform operational check of affected fuel system (TM 55-1520-240-T).

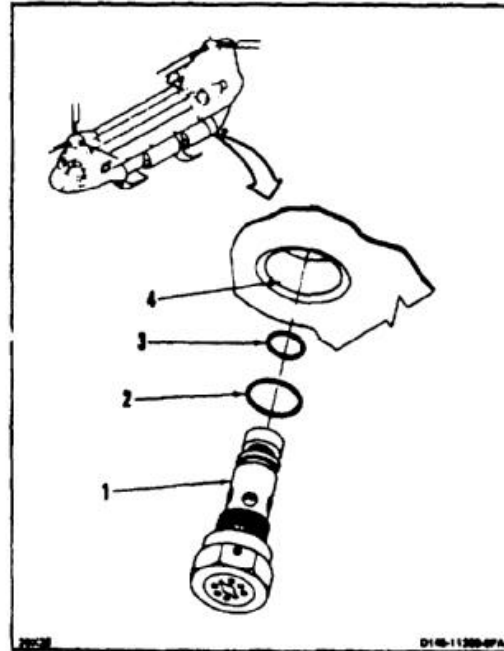

END OF TASK

**SECTION III
FUEL SYSTEMS**

INITIAL SETUP

Applicable Configurations:

Without **74**

Tools:

As Required

Materials:

As Required

Personnel Required:

Medium Helicopter Repairer (2)
Inspector

References:

- Task 1-37
- Task 4-17
- Task 4-18
- Task 10-36
- Task 10-37
- Task 10-51
- Task 10-52
- Task 10-53
- Task 10-54
- Task 10-69
- Task 10-70
- Task 10-79
- Task 10-80
- TM 55-2840-254-23

Equipment Condition:

- Electrical Power On
- Battery Connected (Task 1-39)
- Helicopter Grounded (Task 1-29)
- Engine Work Platform Open (Task 2-2)
- Engine Access Covers Open (Task 4-49)

NOTE

Procedure is same to isolate contamination in the No. 1 (left) or No. 2 (right) fuel system. No. 1 system is shown here.

1. Remove static fuel filter element (1), fuel control elements (2 and 3) and inlet fuel element (4) (TM 55-2840-254-23).
2. Inspect filter elements (1, 2, 3 and 4). For contamination as follows:
 - a. If contamination is dirt, sand or grit with no metal particles or chips, flush airframe fuel system (Task 10-36) and engine fuel system (Task 10-37).

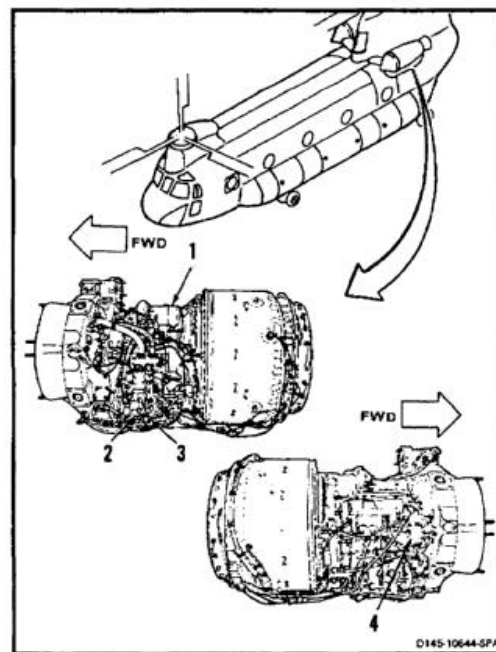
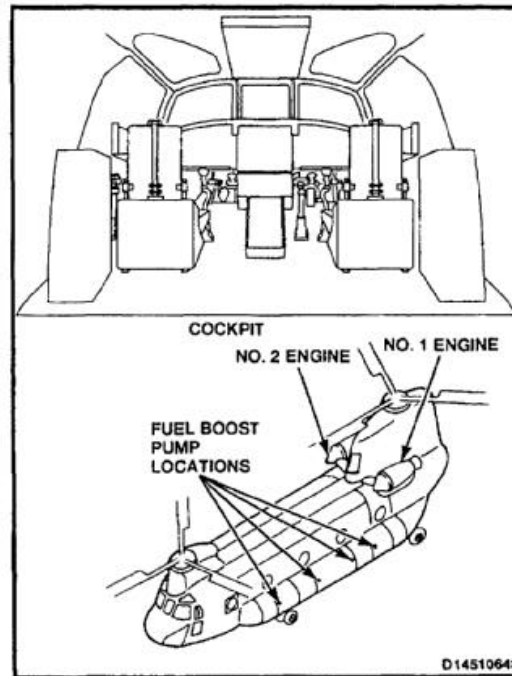

- b. If metal contamination is found in static fuel filter element (1), perform steps 3 thru 25.
- c. If metal is found in fuel control filters (2 or 3) or inline fuel filter (4), perform step 27.
3. Install filters (1, 2, 3 and 4).

METAL IN STATIC FILTER

4. Make sure that there is enough fuel in fuel tanks for proper operation of boost pumps.

5. On PDP No. 1 (5), check that following circuit breakers are closed (pushed in):

- LH FUEL PUMP CONT
- AUX AFT (6)
- MAIN AFT (7)
- MAIN FWD (8)
- AUX FWD (9)

- LH FUEL PUMPS
- MAIN FWD (10)
- MAIN AFT (11)
- AUX FWD (12)
- AUX AFT (13)

- 6. Set FUEL PUMPS LEFT SIDE FWD AUX switch (14) to ON.
- 7. Check FUEL PRESS light (15) goes out.
- 8. Place ear against forward fuel tank (16). If sound of pump is irregular or loud or if light (15) does not go out, the boost pump is defective.
- 9. If necessary, replace boost pump (Tasks 10-69 and 10-70).

NOTE

A seized forward tank boost pump can trip its LH FUEL PUMPS circuit breaker (12).

10. Set switch (14) to OFF.

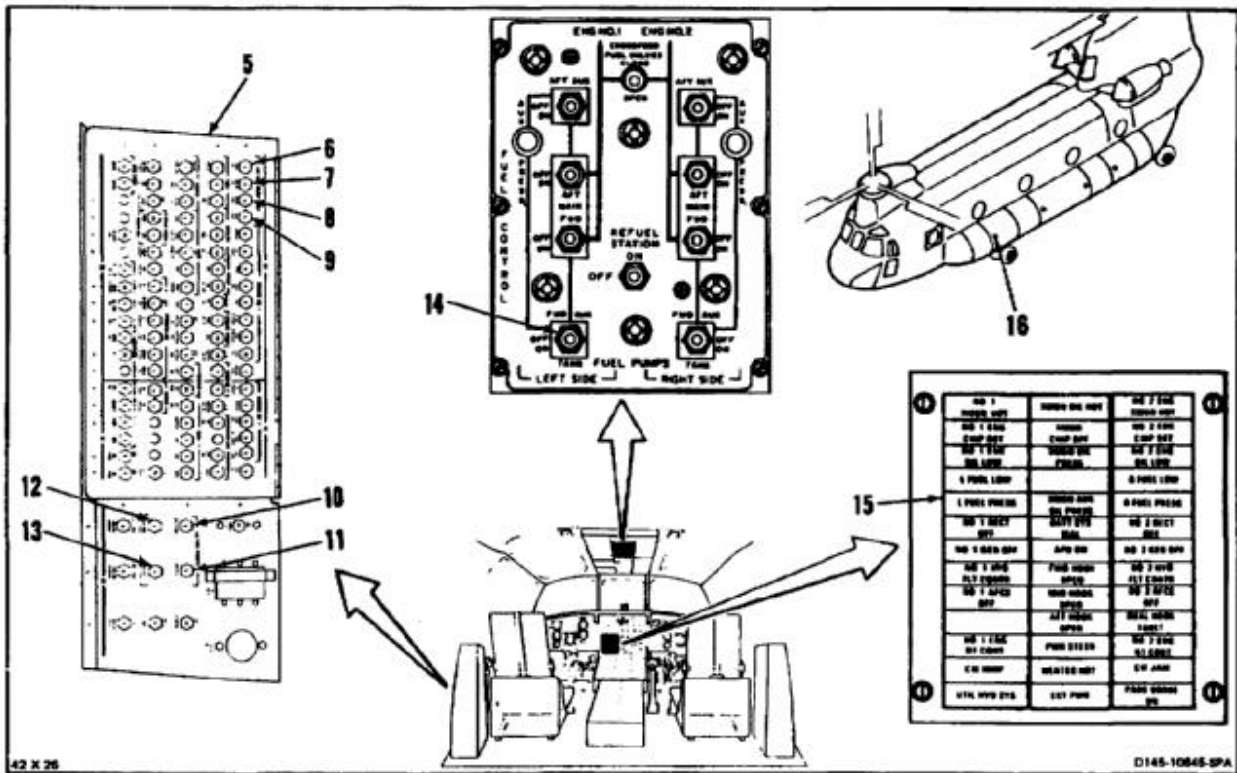

10-33 ISOLATING CONTAMINATION (Continued)**10-33**

11. Set FUEL PUMPS LEFT SIDE AFT AUX switch (17) to ON.
12. Check L FUEL PRESS light (15) goes out.
13. Place ear against aft fuel tank (18). If sound of pump is irregular or loud or if light (15) does not go out, the boost pump is defective.
14. If necessary, replace boost pump (Tasks 10-79 and 10-80).

NOTE

A seized aft tank boost pump can trip its LH FUEL PUMPS circuit breaker.

15. Set switch (17) to OFF.
16. Set FUEL PUMPS LEFT SIDE MAIN FWD. switch (19) to ON.
17. Check L FUEL PRESS light (15) goes out.
18. Place ear against main fuel tank (20). If sound of pump is irregular or loud or if light (15) does not go out, the boost pump is defective.
19. If necessary, replace boost pump (Tasks 10-51 and 10-52).

NOTE

A seized main forward boost pump can trip LH FUEL PUMPS circuit breaker (10).

20. Set switch (19) to OFF.

21. Set FUEL PUMPS LEFT SIDE MAIN AFT switch (21) to ON.
22. Check L FUEL PRESS light (15) goes out.
23. Place ear against main fuel tank (22). If sound of pump is irregular or loud or if light (15) does not go out, the boost pump is defective.
24. If necessary, replace boost pump (Tasks 10-53 and 10-54).

NOTE

A seized main aft boost pump can trip its LH FUEL PUMPS circuit breaker.

25. Set switch (21) to OFF.
26. If all fuel tank boost pumps are satisfactory, replace engine fuel boost pump (Tasks 4-17 and 4-18).

METAL IN FUEL CONTROL FILTER OR INLINE FUEL FILTER

27. Replace engine fuel control unit (TM 55-2840-254-23).
28. Disconnect ac power (Task 1-37).

INSPECT**FOLLOW-ON MAINTENANCE:**

- Close engine access cover (Task 4-50).
- Close engine work platform (Task 2-2).

INITIAL SETUP

Applicable Configurations:

With **74**

Tools:

Aircraft Mechanic's Tool Kit, NSN 5180-00-323-4692

Materials:

None

Personnel Required:

Medium Helicopter Repairer (2)
Inspector

References:

Task 4-17
Task 4-18
Task 10-36
Task 10-37
Task 10-51
Task 10-52
Task 10-53
Task 10-54
Task 10-69
Task 10-70
Task 10-79
Task 10-80
TM 1-2840-265-23

Equipment Condition:

Electrical Power On
Battery Connected (Task 1-39)
Helicopter Grounded (Task 1-29)
Engine Work Platform Open (Task 2-2)
Engine Access Covers Open (Task 4-49)

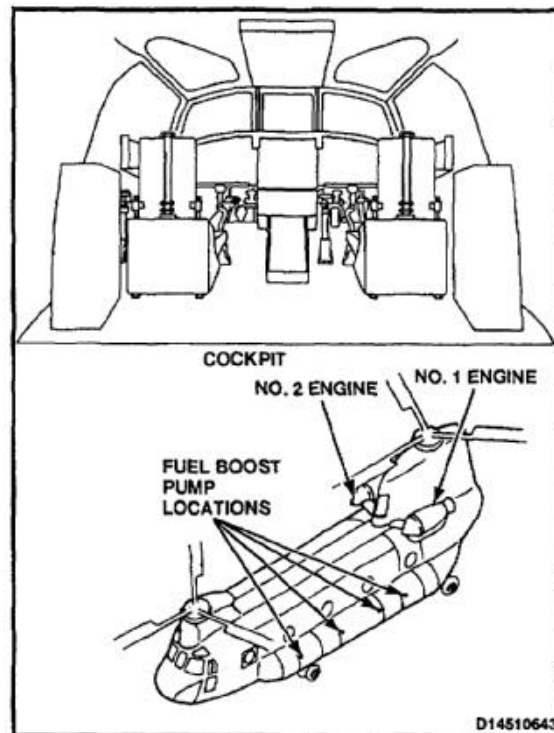

NOTE

Procedure is similar to isolate contamination in the No. 1 (left) or No. 2 (right) fuel system. No. 1 system shown here.

1. Remove the element from barrier fuel filter (1) and inline fuel filter (2). Remove hydromechanical unit (HMU) screen (3) (TM 1-2840-265-23).
 2. Inspect elements from filters (1 and 2) and screen (3) for contamination.
- a. If contamination is dirt, sand or grit with no metal particles or chips, flush airframe fuel system (Task 10-36) and engine fuel system (Task 10-37). Go to Follow-On Maintenance.
 - b. If metal contamination is found in barrier element of barrier fuel filter (1), perform steps 2 thru 14.
 - c. If metal is found in element of inline fuel filter (2) or HMU screen (3), replace the HMU (TM 1-2840-265-23).
3. Install elements in filters (1 and 2). Install HMU screen (3).

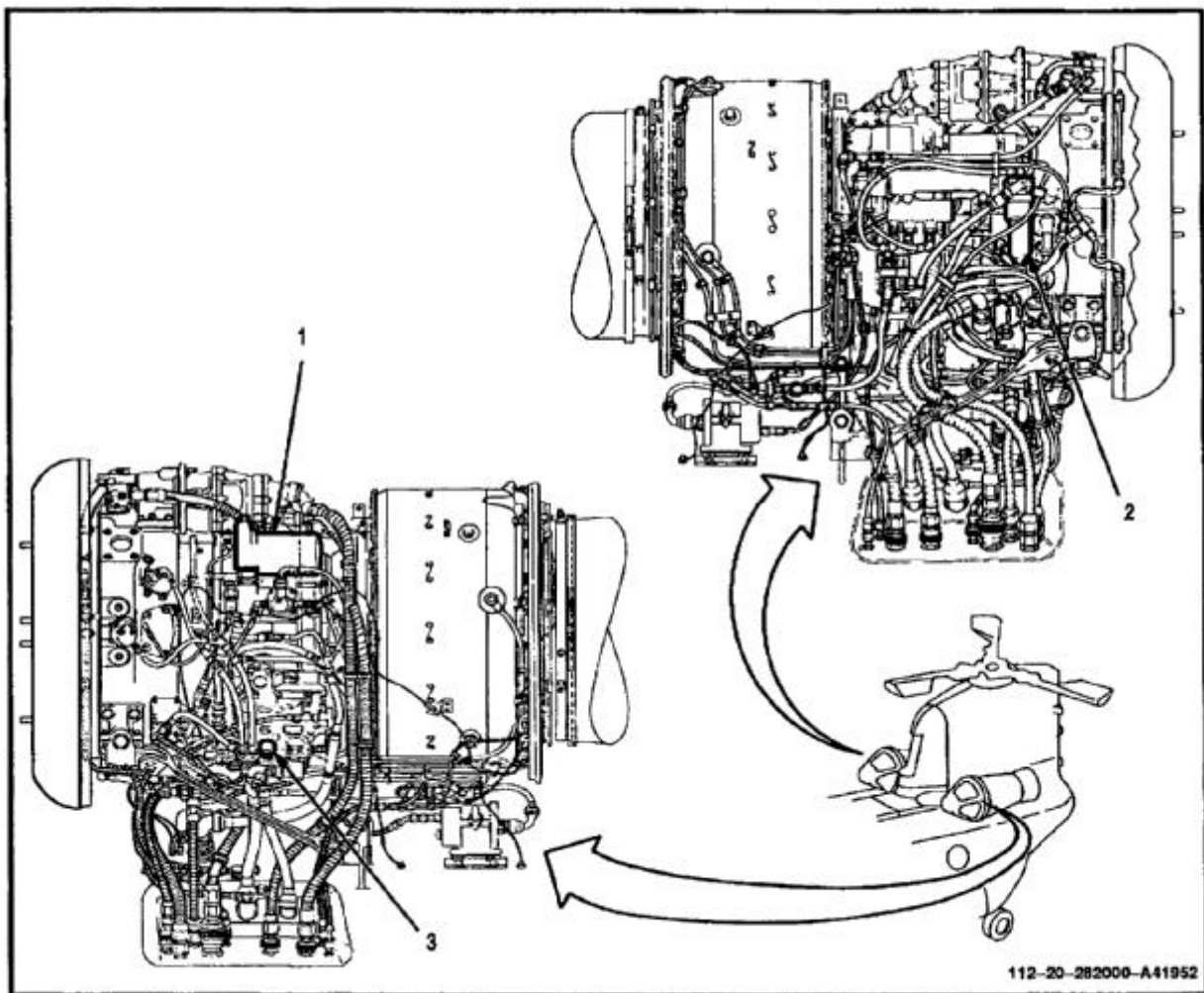

METAL IN MAIN FILTER

4. Make sure that there is enough fuel in the fuel tanks for proper operation of boost pumps.
5. On No. 1 power distribution panel (4), check that following circuit breakers are closed (pushed in):

LH FUEL PUMPS
 MAIN FWD (5)
 MAIN AFT (6)
 AUX FWD (7)
 AUX AFT (8)

LH FUEL PUMP CONT
 MAIN FWD (9)
 MAIN AFT (10)

6. Set the FWD AUX TANK switch (11) on ON.
7. Check that the L FUEL PRESS light (12) on the master caution panel goes out.
8. Place an ear against fuel tank (14) in the area of forward boost pump (13). If the sound of pump is irregular or loud, the pump is defective. If necessary, replace boost pump (Tasks 10-69 and 10-70).

NOTE

A seized forward boost pump can trip LH FUEL PUMP FWD circuit breaker (7).

9. Set switch (11) to OFF.

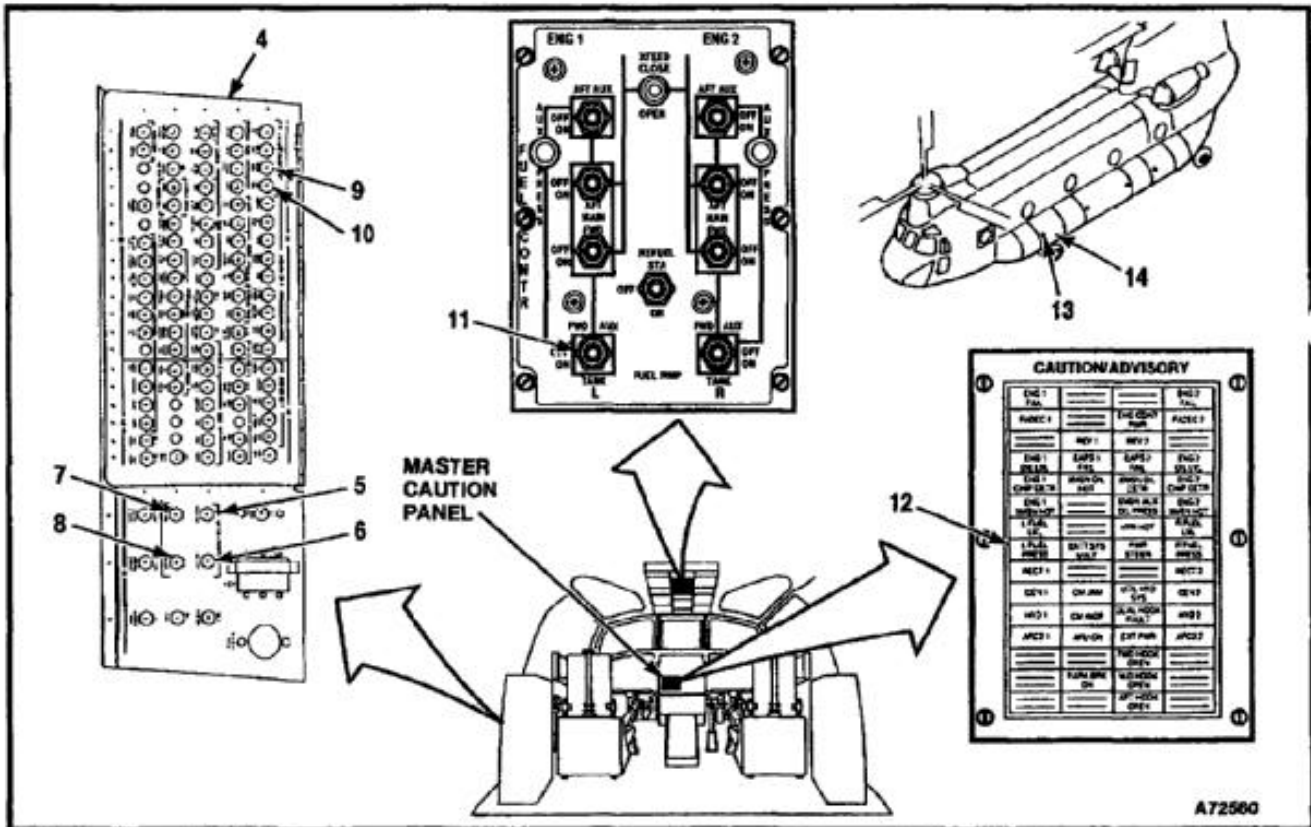

10-33.1 ISOLATING CONTAMINATION (Continued)

10-33.1

- 10. Set the L AFT AUX switch (15) to ON.
- 11. Check that the L FUEL PRESS light (12) goes out.
- 12. Place an ear against fuel tank (16) in the area of aft boost pump (17). If the sound of pump is irregular or loud, the boost pump is defective. Replace the boost pump (Tasks 10-79 and 10-80).

NOTE

A seized main aft boost pump can trip its LH FUEL PUMP circuit breaker (8).

- 13. Set switch (15) to OFF.
- 14. Set L MAIN FWD switch (18) to ON.
- 15. Check L FUEL PRESS light (12) goes out.
- 16. Place ear against main fuel tank (19). If sound of pump is irregular or loud or if light (12) does not go out, the boost pump is defective.
- 17. If necessary, replace boost pump (Tasks 10-51 and 10-52).

NOTE

A seized main forward boost pump can trip LH FUEL PUMPS circuit breaker (5).

- 18. Set switch (18) to OFF.
- 19. Set L MAIN AFT switch (20) to ON.
- 20. Check L FUEL PRESS light (12) goes out. Place ear against main fuel tank (21). If sound of pump is irregular or loud or if light (12) does not go out, the boost pump is defective. If necessary, replace boost pump (Tasks 10-53 and 10-54).

NOTE

A seized main aft boost pump can trip its LH FUEL PUMPS circuit breaker (6).

- 21. Set switch (20) to OFF.
- 22. If all fuel tank boost pumps are satisfactory, replace engine fuel boost pump (Tasks 4-17 and 4-18).

INSPECT

FOLLOW-ON MAINTENANCE:

- Disconnect ac power (Task 1-37).
- Close engine access cover (Task 4-50).
- Close engine work platform (Task 2-2).

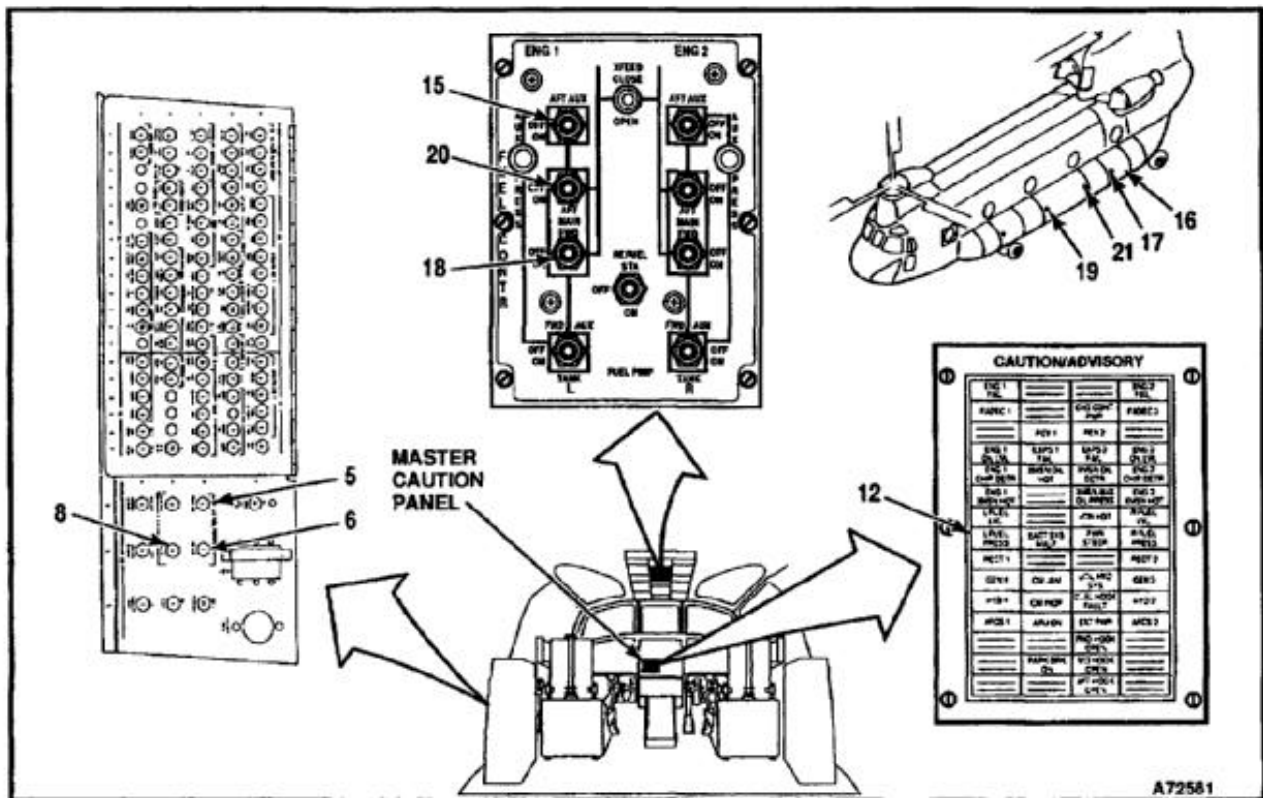

END OF TASK

INITIAL SETUP

Applicable Configurations:

All

Tools:

Aircraft Mechanic's Tool Kit, NSN 5180-00-323-4692
 Grounded Container, 5 Gallon or Equivalent

Materials:

Cloths (E135)

Personnel Required:

Petroleum Supply Specialist
 Medium Helicopter Repairer

References:

FM 10-68

Equipment Condition:

Helicopter Parked on Level Ground at Least 50 Feet
 From Hangar or Structure (Task 1-25)

Battery Connected (Task 1-39)
 Apply Electrical Power (Task 1-37)
 Helicopter Grounded (Task 1-29)
 Defueling Vehicle Grounded to Helicopter Cargo
 Ramp Open (TM 55-1520-240-T)

General Safety Instructions:

WARNING

Proper electrical grounding is essential to prevent damage to equipment and injury to personnel.

WARNING

All regulations and instructions for handling fuels shall be strictly observed.

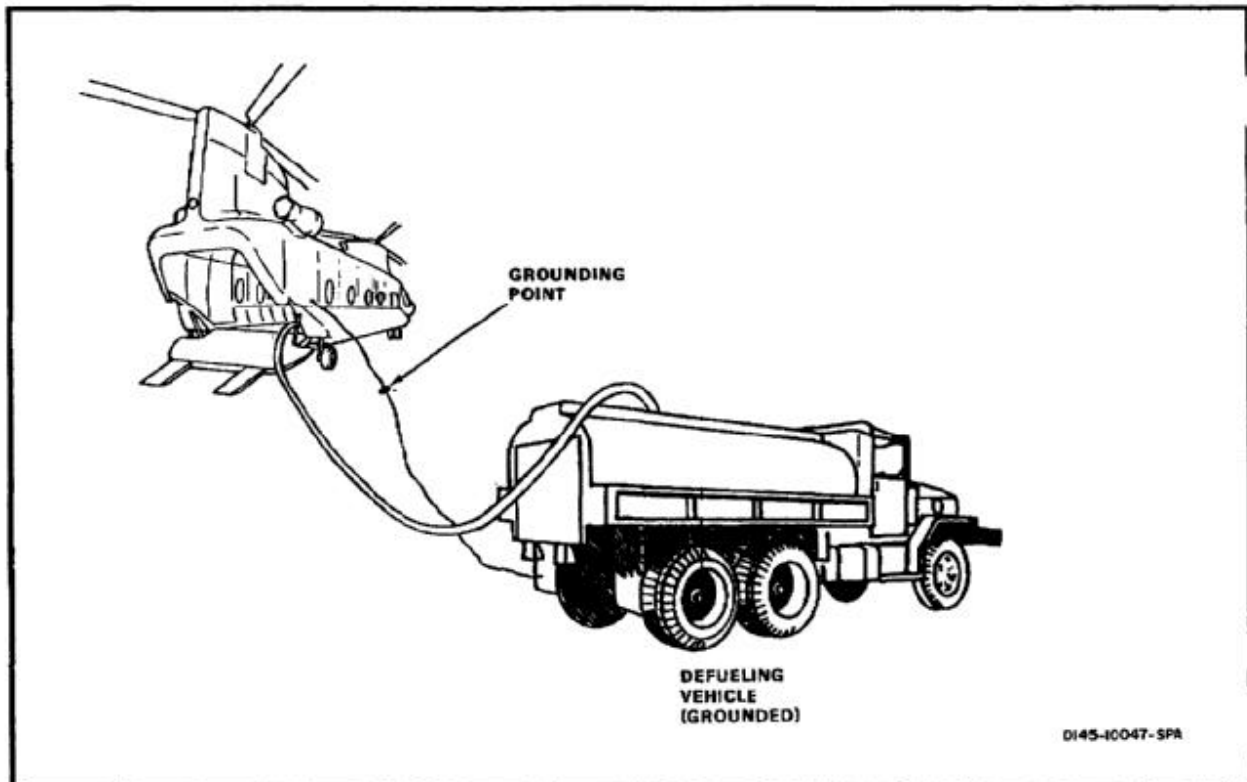

D145-10047-SPA

1. Connect ground wire (1) of defueling hose (2) to helicopter ground point (3) (FM 10-68).

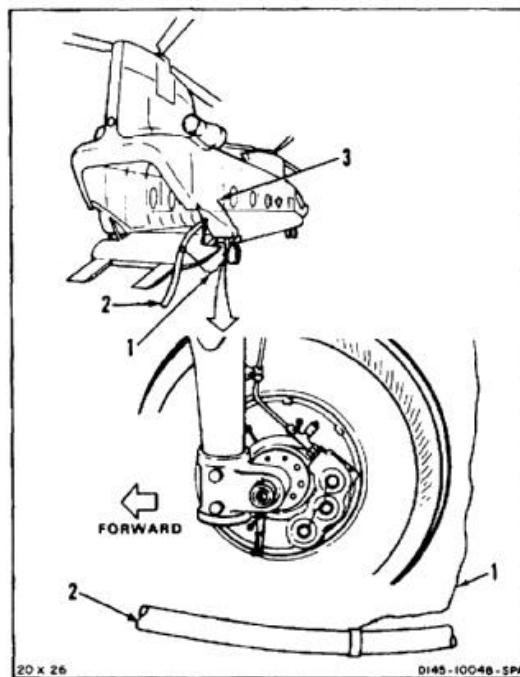

2. Manually close APU shutoff valve lever (4).

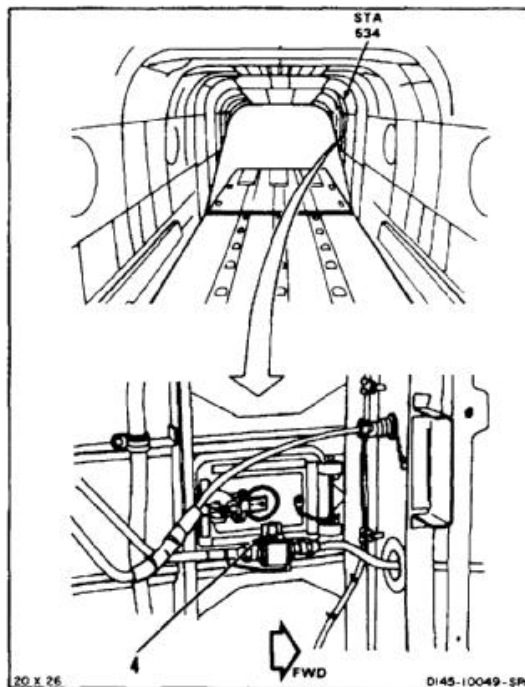

3. Manually close engine No. 1 fuel shutoff valve lever (5).
4. Manually close engine No. 2 fuel shutoff valve lever (6).

NOTE

Disconnect electrical cable from valve(s).

5. Manually close defueling valve lever (7).
6. Remove blanking cap (8). Connect hose connector (9) to elbow (10).

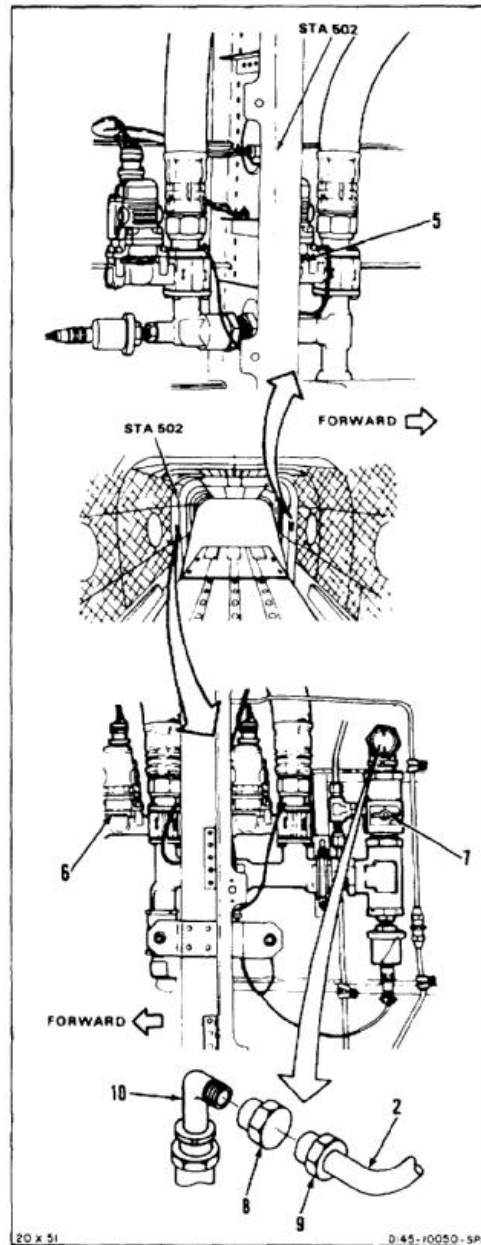

NOTE

Fuel tanks may be defueled all together or one at a time.

DEFUEL ALL TANKS

10. On overhead panel (11) set eight ENG No. 1 and ENG No. 2 switches (15, 16, 17 and 18) to ON.
11. Observe panel (19), when L FUEL PRESS light (20) comes on, set four ENG No. 1 switches (15 and 16) to off. When right fuel pressure light (21) comes on, set four ENG No. 2 switches (17 and 18) to off.
12. Go to step 22.

DEFUEL ANY MAIN TANK

13. On overhead panel (11), set applicable MAIN AFT and MAIN FWD switches (16 or 18) to ON.
14. Observe panel (19). When applicable fuel pressure light (20 or 21) comes on, set applicable switches (16 or 18) to OFF.
15. Go to step 22.

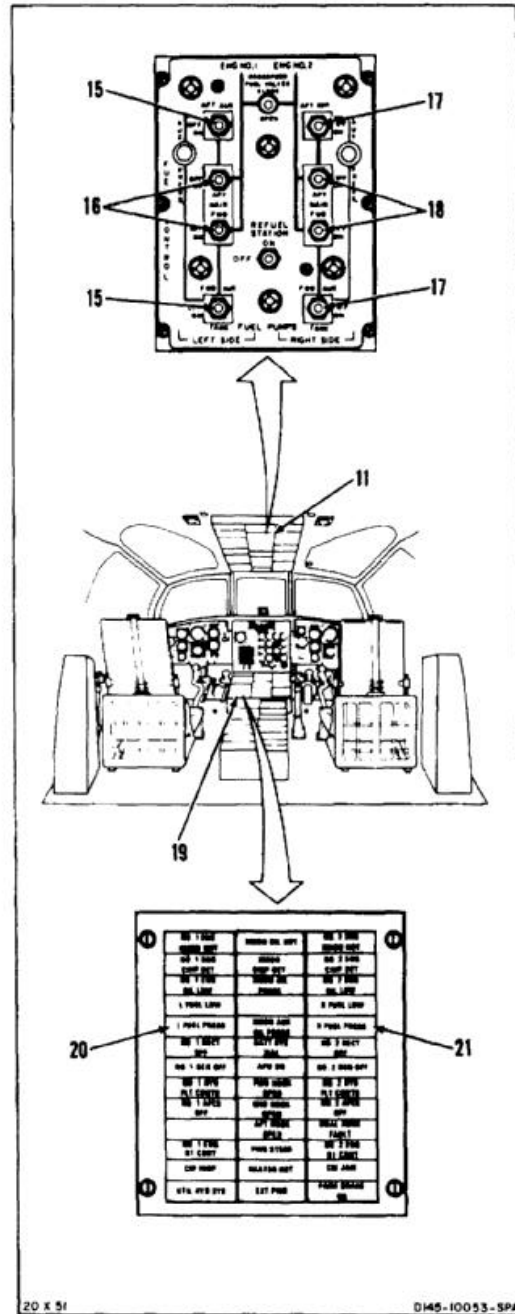

DEFUEL ANY FORWARD OR AFT TANK

16. Set FUEL QUANTITY selector (22) to position applicable to tank(s) to be defueled.
17. Note reading(s) on indicator (23). Subtract reading from 1700. Note resultant figure.
18. Set MAIN AFT and MAIN FWD switches (16 or 18), for applicable side of helicopter, to ON.
19. Observe indicator (23). When indicator reads below resultant figure in step 17, set switches (16 or 18) to OFF.
20. Set applicable AFT AUX or FWD AUX switch (15 or 17) to ON.
21. Observe panel (11). When applicable FUEL PRESS light (24 or 25) comes on, set switch(es) (15 or 17) to OFF.

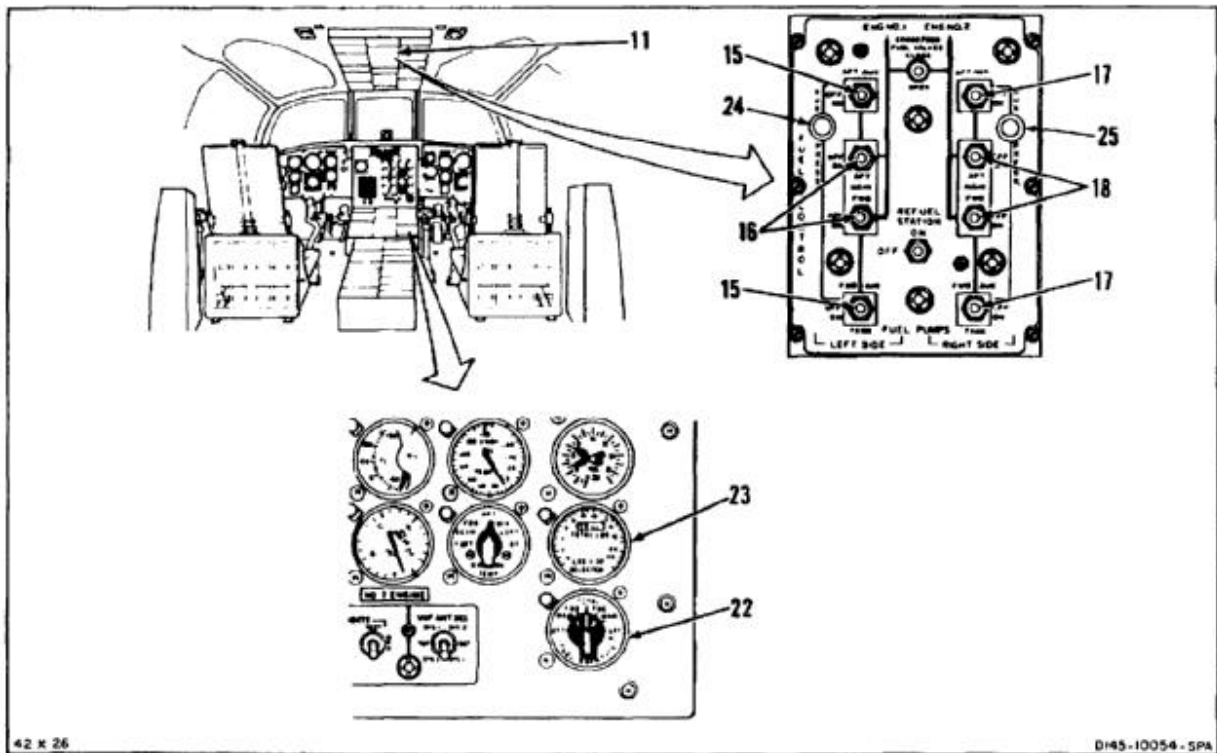

22. Manually close defueling valve lever (7).
23. Disconnect hose connector (9). Install blanking cap (8).

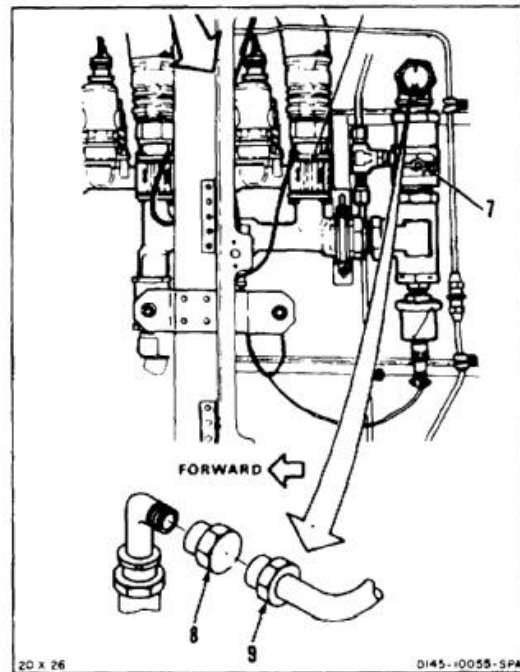

24. Disconnect ground wire (1) of hose (2) from helicopter ground point (3). Remove hose from helicopter.
25. Remove ac power from helicopter (Task 1-37).

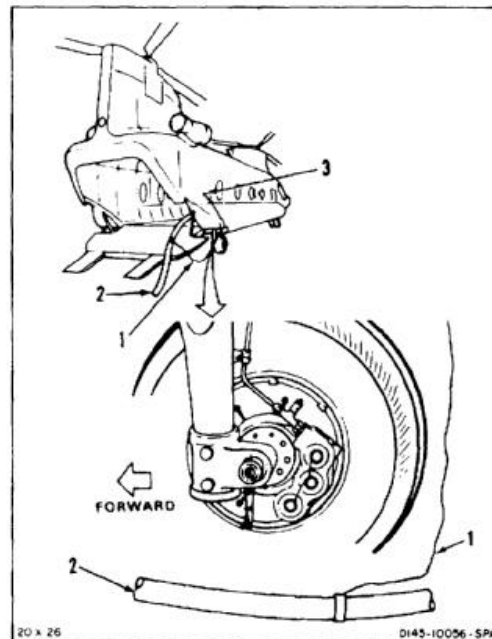

26. Position grounded container(s) (26) under drain valves (27 and 28) of applicable tank(s).
27. Insert screwdriver in slot (29) of forward drain valve (27). Push up and turn drain valve stem (30) clockwise. Drain remaining fuel into container (26). Remove screwdriver.
28. Insert screwdriver in slot (31) of aft drain valve (28). Drain remaining fuel into container (26). Remove screwdriver.
29. Remove grounded container(s) (26).
30. Clean up any spilled fuel. Use cloths (E135).

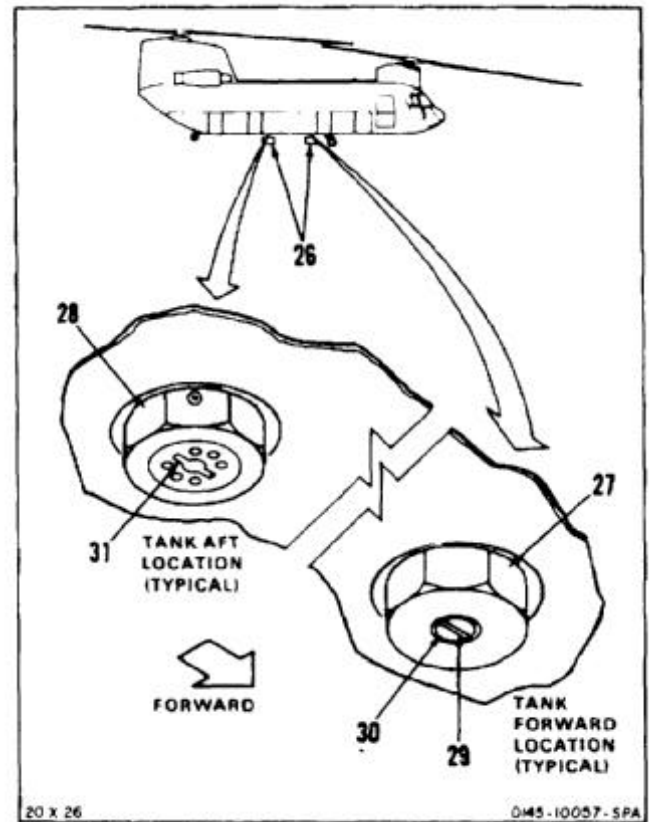

31. Manually open APU shutoff valve lever (4).

FOLLOW-ON MAINTENANCE:

None

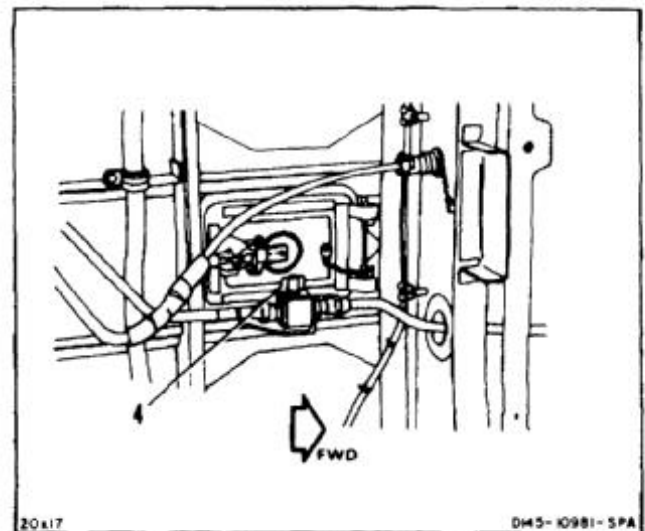

END OF TASK

INITIAL SETUP

Applicable Configurations:

All

Tools:

Aircraft Mechanic's Tool Kit, NSN 5180-00-323-4692
 Grounded Container, 5 Gallon or Equivalent

Materials:

Cloths (E135)

Personnel Required:

Petroleum Supply Specialist
 Medium Helicopter Repairer

References:

FM 10-68

Equipment Condition:

Helicopter Parked on Level Ground at Least 50 Feet
 From Hangar or Structure (Task 1-25)
 Battery Disconnected (Task 1-39)
 Electrical Power Off
 Helicopter Grounded (Task 1-29)
 Defueling Vehicle Grounded to Helicopter

General Safety Instructions:

WARNING

Proper electrical grounding is essential to prevent damage to equipment and injury to personnel.

WARNING

All regulations and instructions for handling fuels shall be strictly observed.

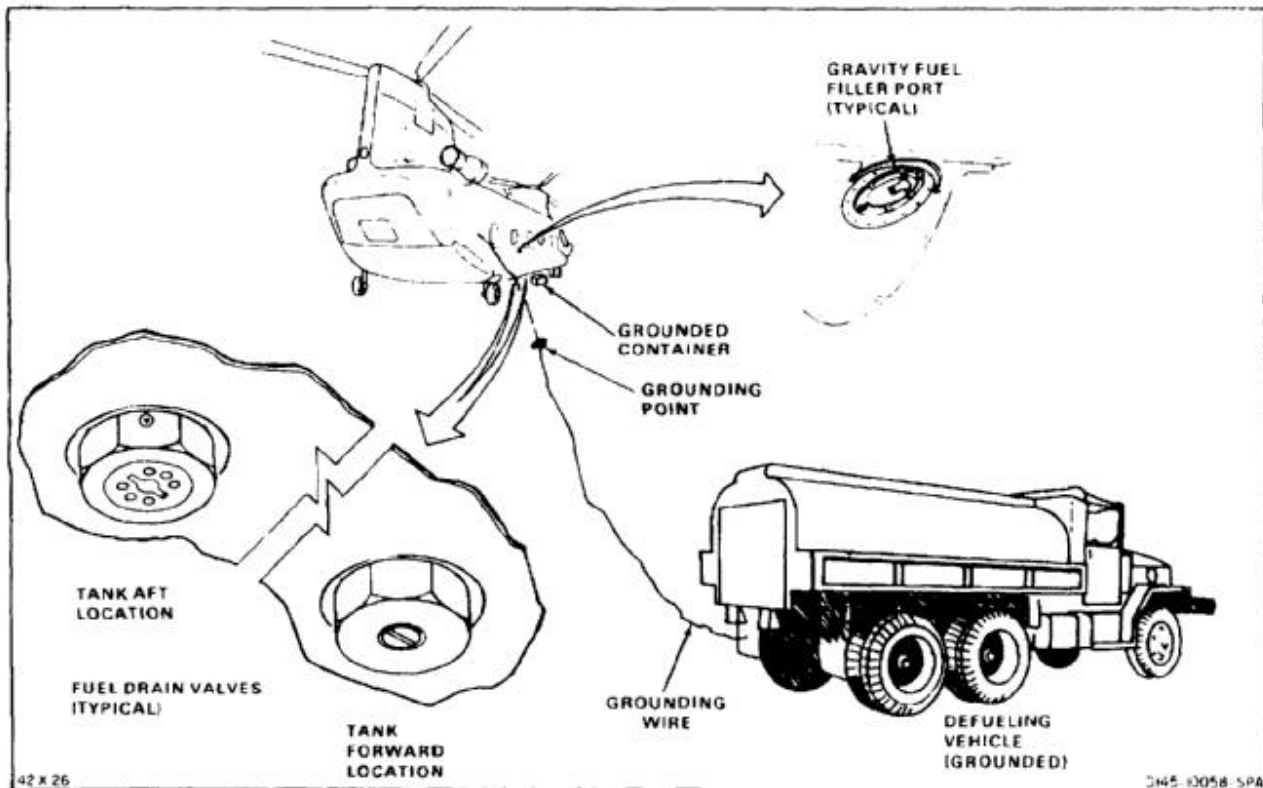

NOTE

Procedure is same to defuel any fuel tank. Defueling of right main tank is shown here.

1. Attach hose grounding lead (1) into helicopter ground socket (2) (FM 10-68).
2. Raise filler cap latch (3). Rotate cap (4) counterclockwise. Remove cap and allow it to hang on retention chain (5).



Take care when inserting and removing defueling hose. Damage to cell walls and internal components can result.

3. Insert defueling hose (6) into filler opening (7).
4. Defuel tank cell.
5. Remove defueling hose (6) from helicopter.
6. Remove lead (1) from socket (2).
7. Install and lock filler cap (4).

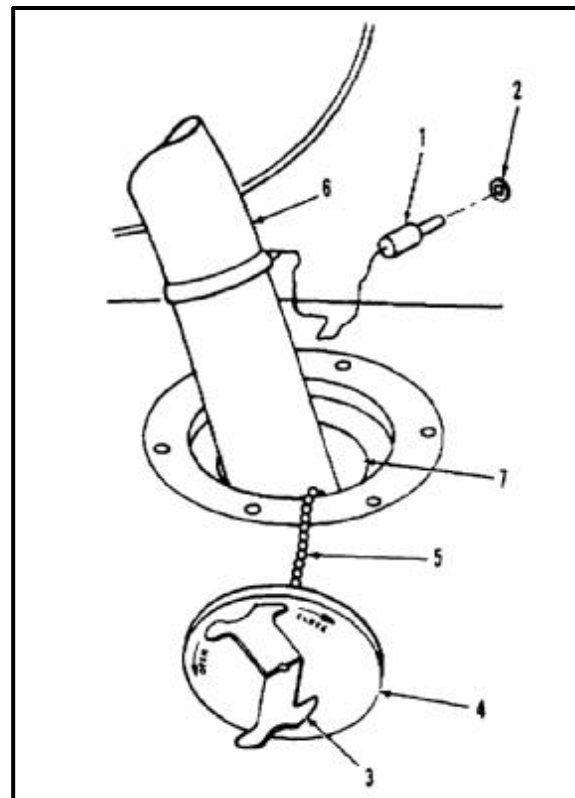

8. Position grounded container(s) (8) under drain valves (9 and 10) of applicable tank(s).
9. Insert screwdriver in slot (11) of forward drain valve (9). Push up and turn drain valve stem (12) clockwise. Drain remaining fuel into container (8). Remove screwdriver.
10. Insert screwdriver in slot (13) of aft drain valve (10). Turn drain valve stem (14) counterclockwise. Drain remaining fuel into container (8). Remove screwdriver.
11. Remove grounded container(s) (8).
12. Clean up any spilled fuel. Use cloths (E135).

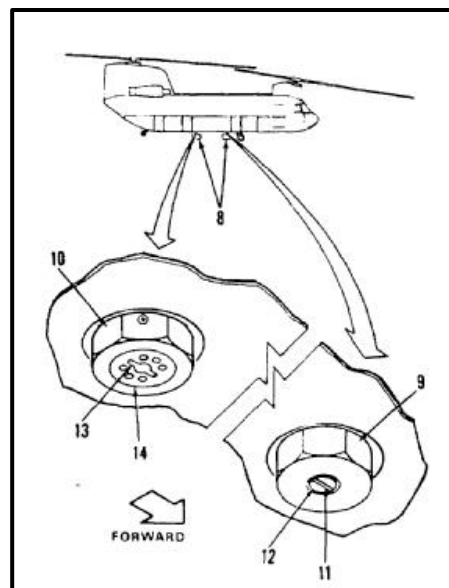
**FOLLOW-ON MAINTENANCE:**

None

END OF TASK

INITIAL SETUP

Applicable Configurations:

All

Tools:

Aircraft Mechanic's Tool Kit, NSN 5180-00-323-4692
 Drain Hoses (2), Approximately 16 Feet Long, One End to Have 7/8 Inch Standard Male Union
 Drain (1), Approximately 16 Feet Long, One End to Have 9/16 Inch Standard Male Union
 Air Supply, Approximately 80 psi
 Container, 2 Gallon
 Grounded Container, 50 Gallon or Equivalent

Materials:

Cloths (E135)
 Solvent (E162)
 Vinegar (E436)
 Gloves (E186)

Personnel Required:

Medium Helicopter Repairer (2)
 Inspector

References:

Task 1-37
 Task 10-9
 Task 10-51

Task 10-52
 Task 10-54
 Task 10-70
 Task 10-80
 Task 10-117
 Task 10-118
 Task 10-119
 Task 10-120
 TM 1-2840-265-23 (With **74**)
 TM 55-2840-254-23 (Without **74**)

Equipment Condition:

Battery Disconnected (Task 1-39)
 Electrical Power Off
 Helicopter Grounded (Task 1-29)
 Helicopter Defueled (Task 10-34 or 10-35)
 Fuel Tanks Purged (Task 10-2)
 All Fuel Boost Pumps Removed (Tasks 10-69, 10-51, 10-53, and 10-79)
 Engine Work Platforms Open (Task 2-2)
 Engine Access Covers Open (Task 4-49)

General Safety Instructions:

WARNING

All regulations and instructions for handling fuels shall be strictly observed.

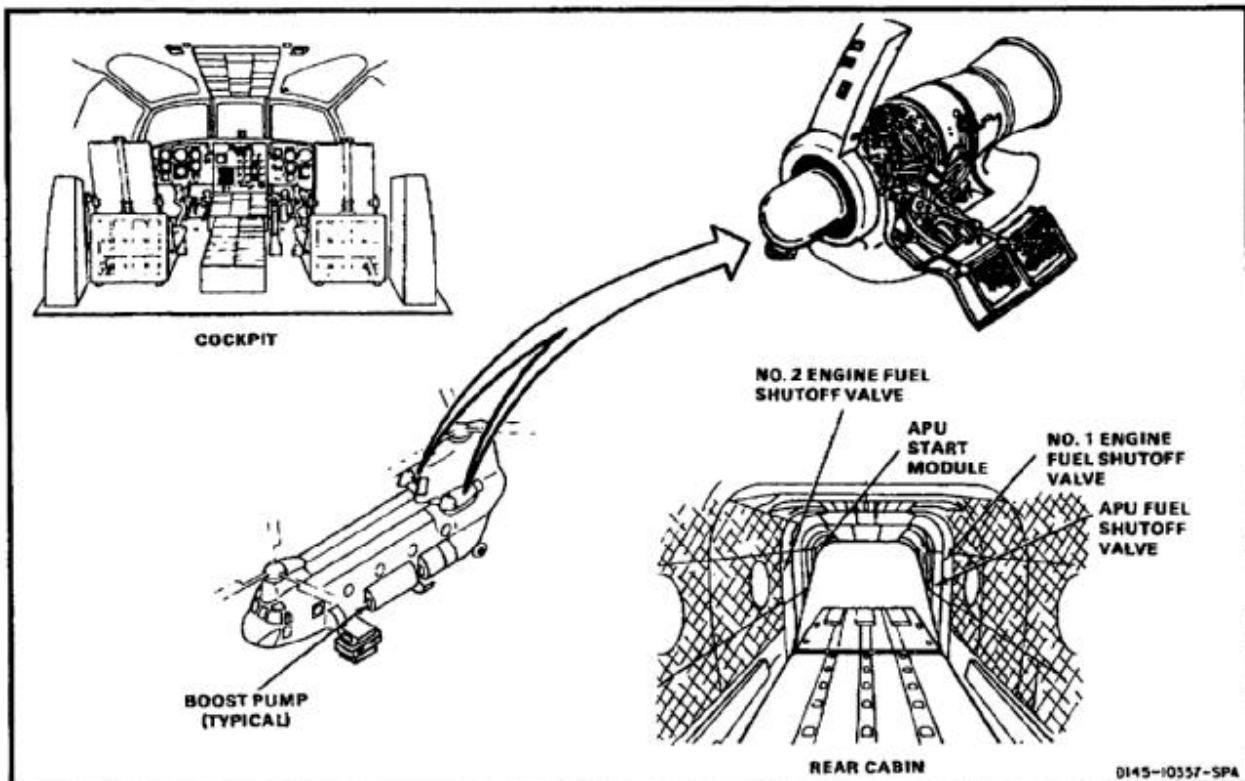

1. Follow instructions of Task 10-9, Fuel Cell Precautionary Criteria, General Information.
2. Inspect interior of fuel cells (1) for dirt or contaminants.
3. Wipe out any dirt or other contaminants. Clean the interior of cells (1). Use clean cloth (E135) damp with **50-50** solution of vinegar (E436) and water.

WARNING

Dry cleaning solvent (E162) is flammable and toxic. It can irritate skin and cause burns. Use only in well-ventilated area, away from heat and open flame. In case of contact, immediately flush skin or eyes with water for at least **15 minutes**. Get medical attention for eyes.

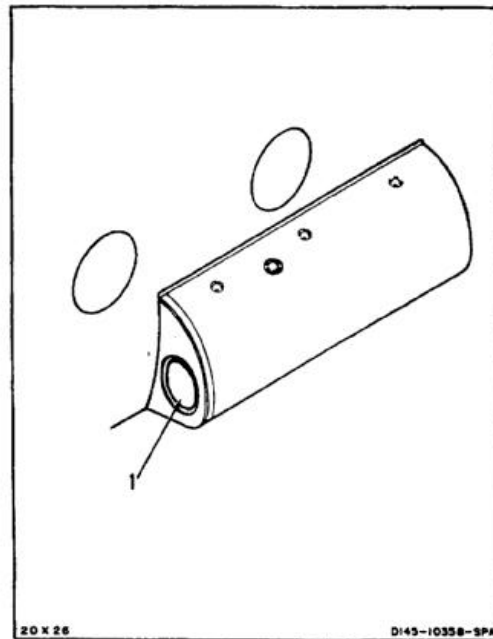

4. Clean boost pump screens (2) by sloshing. Use **2 gallon** container and dry cleaning solvent (E162). Wear gloves (E186).
5. Remove any remaining contaminants from screens (2) with compressed air.
6. Perform vent system pressure test (Task 10-117).
7. Install eight fuel boost pumps (Tasks 10-52, 10-54, 10-70 and 10-80).
8. Perform vent system flow test (Task 10-118), pressure refueling system test (Task 10-119), and fuel feed system test (Task 10-120).
9. Refuel helicopter (Task 1-51).

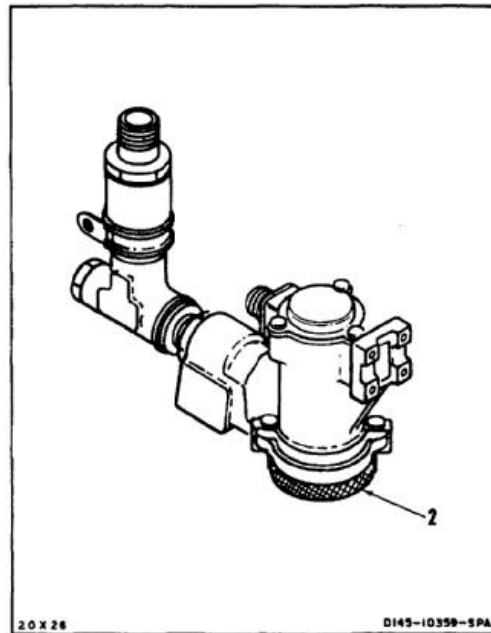

CAUTION

Do not use tape to seal open ports.
Tape adhesive is soluble in fuel and
can cause contamination.

NOTE

Steps 10 thru 13 are without **74**.

10. Disconnect fuel hose (3) from engine fuel control nipple (4) on both engines (5). Cap nipple on fuel control.
11. Connect one drain hose (6) to fuel hose (3) on each engine (5). Place free end of each drain hose in grounded container (7).
12. Attach grounding wire (8) on each drain hose (6) to grounded container (7).
13. Apply ac power to helicopter (Task 1-37).

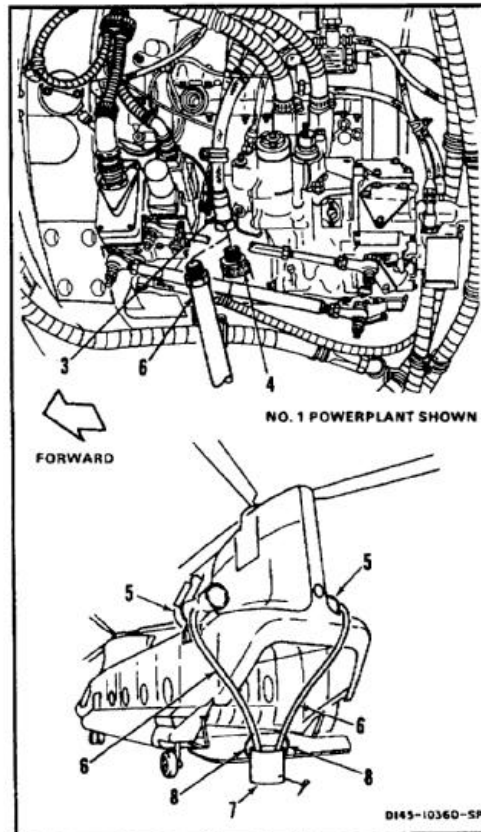

NOTE

Steps 14 thru 18 are with **74**.

14. Remove screw (3) and nut (4) from clamp (5) on fuel supply hose (6). Separate hose from hose (7).
15. Wearing gloves (E184.1), disconnect fuel supply hose (6) from union (8) on both engines (9). Cap union.
16. Attach grounding wire (10) from each drain hose (11) to grounded container (12).
17. Connect one drain hose (11) to fuel supply hose (6) on each engine (9). Place free end of each drain hose in grounded container (12).
18. Apply ac power to helicopter (Task 1-37).

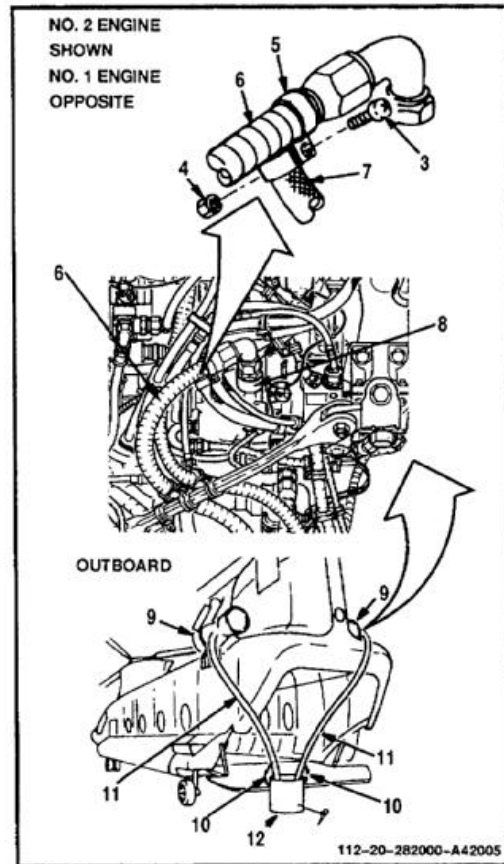

NOTE

Steps 19 thru 23 are without **74**.

- 19. On No. 1 PDP panel (9), check that following circuit breakers are closed (pushed in).

XFEED CONT (10)
 LH FUEL PUMP CONT
 AUX AFT (11)
 MAIN AFT (12)
 MAIN FWD (13)
 AUX FWD (14)

LH FUEL PUMPS
 MAIN FWD (15)
 MAIN AFT (16)
 AUX FWD (17)
 AUX AFT (18)

APU CONT
 NORM (19)
 EMERG (20)

- 20. On No. 1 PDP panel (9), open (pull out) FUEL SHUT OFF circuit breaker (21).

- 21. On No. 2 PDP panel (22) check that following circuit breakers are closed (pushed in).

RH FUEL PUMP CONT
 AUX AFT (23)
 MAIN AFT (24)
 MAIN FWD (25)
 AUX FWD (26)

RH FUEL PUMPS
 MAIN FWD (27)
 MAIN AFT (28)
 AUX FWD (29)
 AUX AFT (30)

- 22. On No. 2 PDP panel (22) open (pull out) FUEL SHUT OFF circuit breaker (31).

- 23. On overhead panel (32) set CROSSFEED FUEL VALVES switch (33) to OPEN.

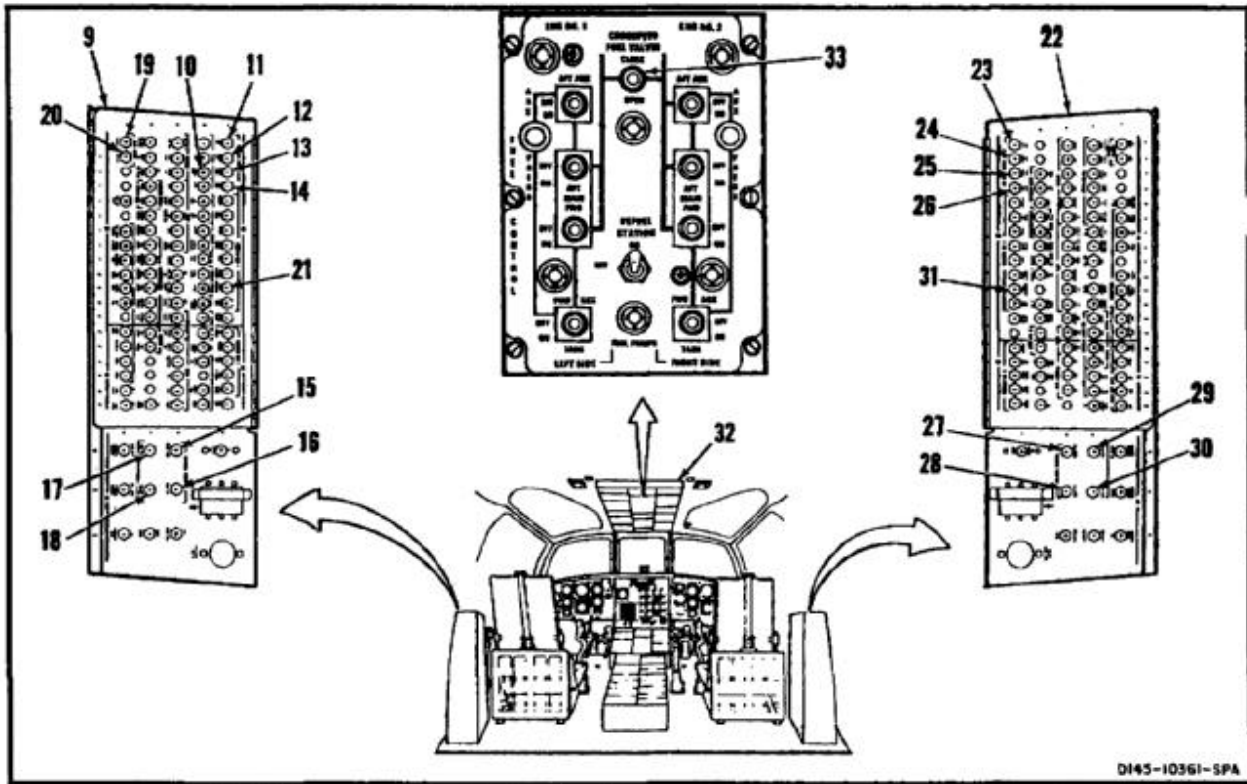

DI45-10361-SPA

NOTE

Steps 24 thru 29 are with **74**.

24. On No. 1 PDP panel (9), check that following circuit breakers are closed (pushed in).

XFEED CONT (10)
LH FUEL PUMP CONT
MAIN AFT (12)
MAIN FWD (13)

LH FUEL PUMPS
MAIN FWD (15)
MAIN AFT (16)
AUX FWD (17)
AUX AFT (18)

APU CONT
NORM (19)
EMERG (20)

25. On No. 1 PDP panel (9), open (pull out) FUEL SHUT OFF circuit breaker (21).

26. On No. 2 PDP panel (22) check that following circuit breakers are closed (pushed in).

RH FUEL PUMP CONT
MAIN FWD (25)
AUX FWD (26)

RH FUEL PUMPS
MAIN FWD (27)
MAIN AFT (28)
AUX FWD (29)
AUX AFT (30)

27. On No. 2 PDP panel (22) open (pull out) FUEL SHUT OFF circuit breaker (31).

28. On overhead panel (32) set CROSSFEED FUEL VALVES switch (33) to OPEN.

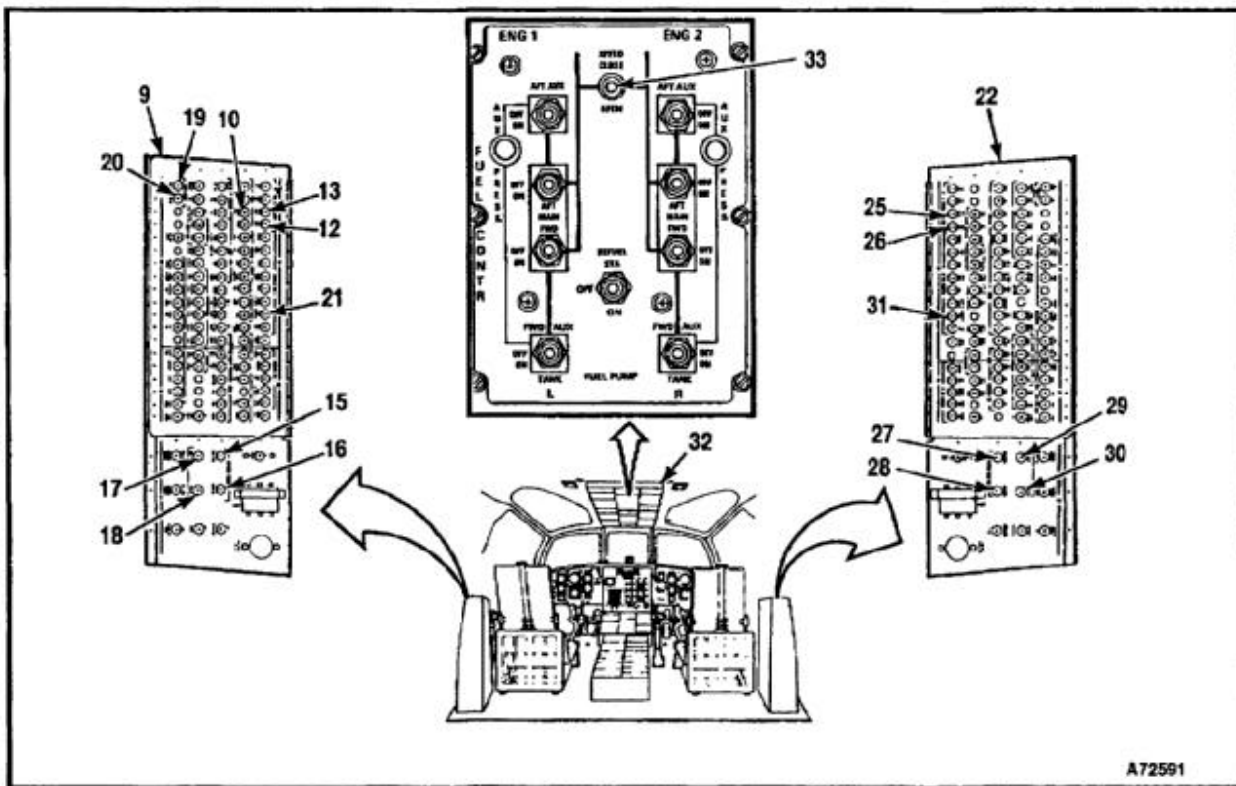

29. Manually move No. 2 engine shutoff valve lever (34) to CLOSE.
30. Make sure No. 1 engine shut off valve lever (35) is at OPEN.

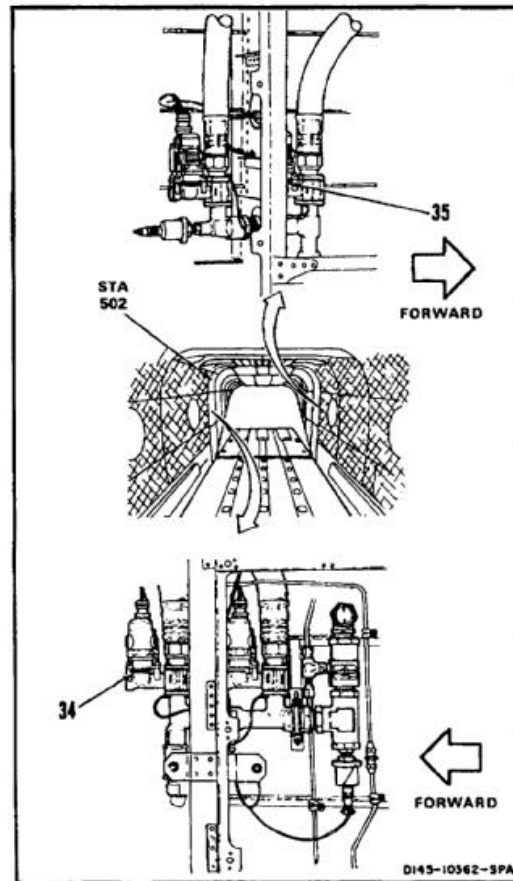

31. Set each of eight FUEL PUMPS switches (36 thru 43) momentarily to ON one at a time.
32. Set all eight FUEL PUMPS switches (36 thru 43) to ON at same time.
33. Set all eight FUEL PUMPS switches (36 thru 43) to OFF when approximately **15 gallons** of fuel has been pumped through open drain hoses (6) into grounded container (7).

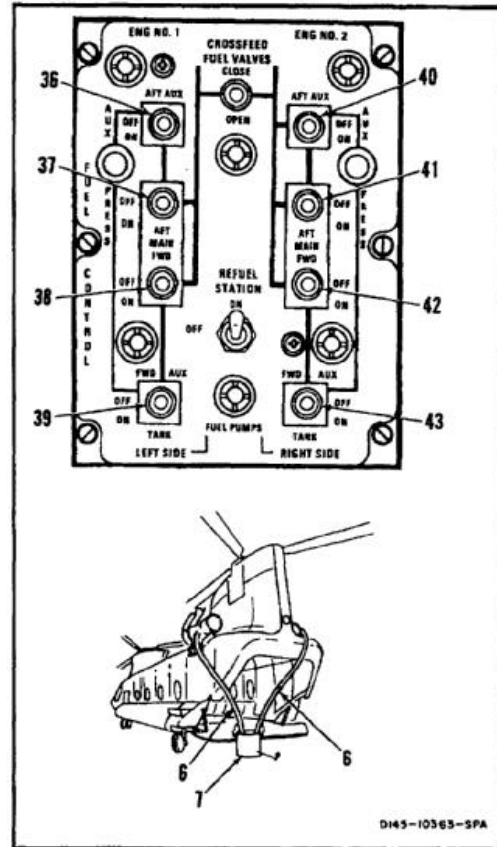

34. Manually move No. 2 engine shutoff valve lever (34) to OPEN.
35. Manually move No. 1 engine shutoff valve lever (35) to CLOSE.
36. Repeat steps 21, 22 and 23.
37. Manually move No. 2 engine shutoff valve lever (34) to CLOSE.

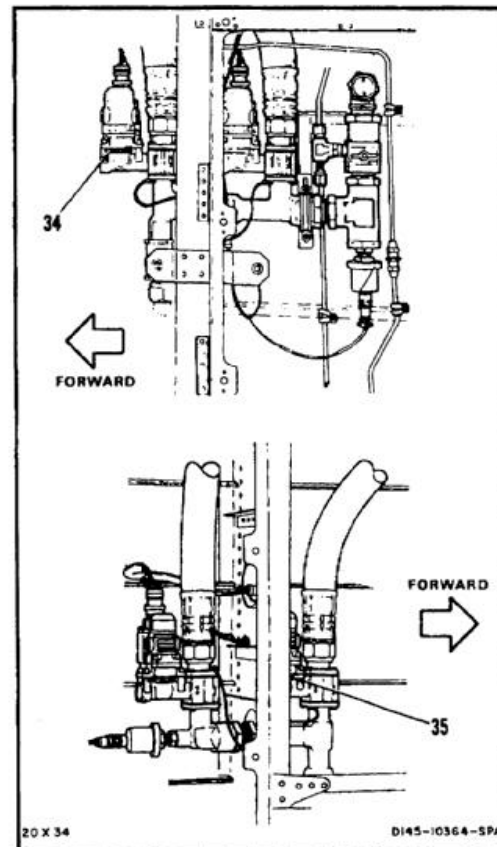

- 38. Press button (44) on APU start module (45).
When sounds of utility hydraulic system depressurizing stop, release button.

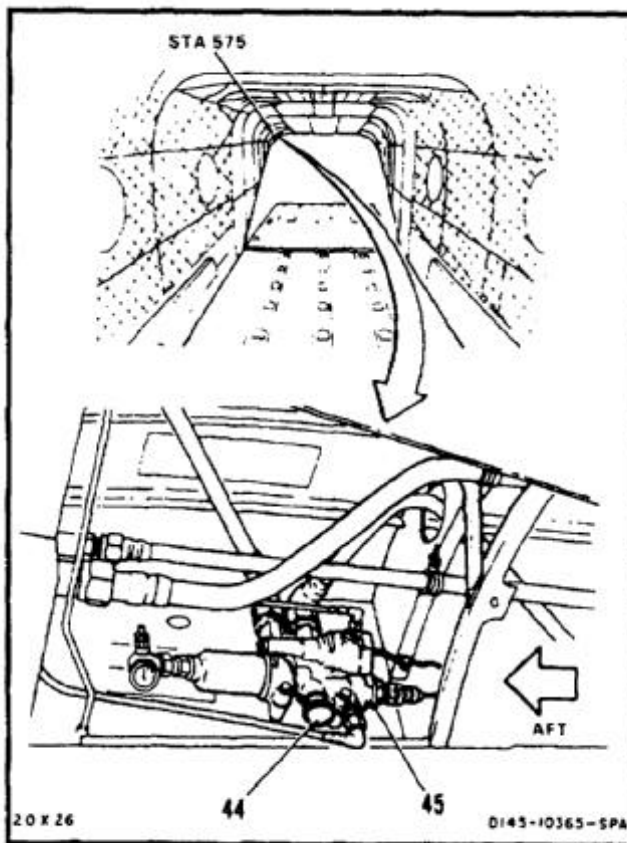

39. Disconnect fuel line (48) from APU shutoff valve (49).
40. Connect drain hose (50) to valve (49).
41. Connect drain hose grounding wire (51) to convenient helicopter ground point (52).
42. Place free end of drain hose (50) in grounded container (7).
43. Make sure APU shutoff valve (49) is OPEN.

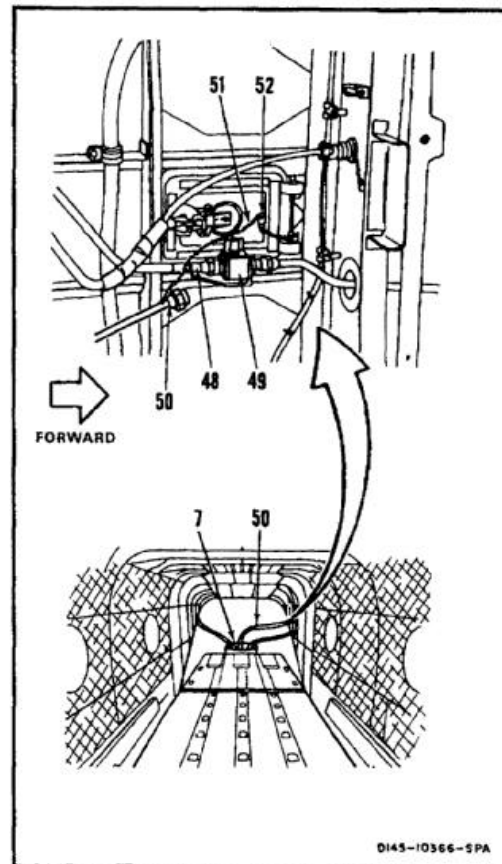

44. Set APU switch (53) to START.
45. Set FUEL PUMP switches (37 and 38) to ON.
46. Allow approximately **2 gallons** of fuel to flow into grounded container (7).
47. Set FUEL PUMP switches (37 and 38) to OFF.
48. Set APU switch (53) to OFF.

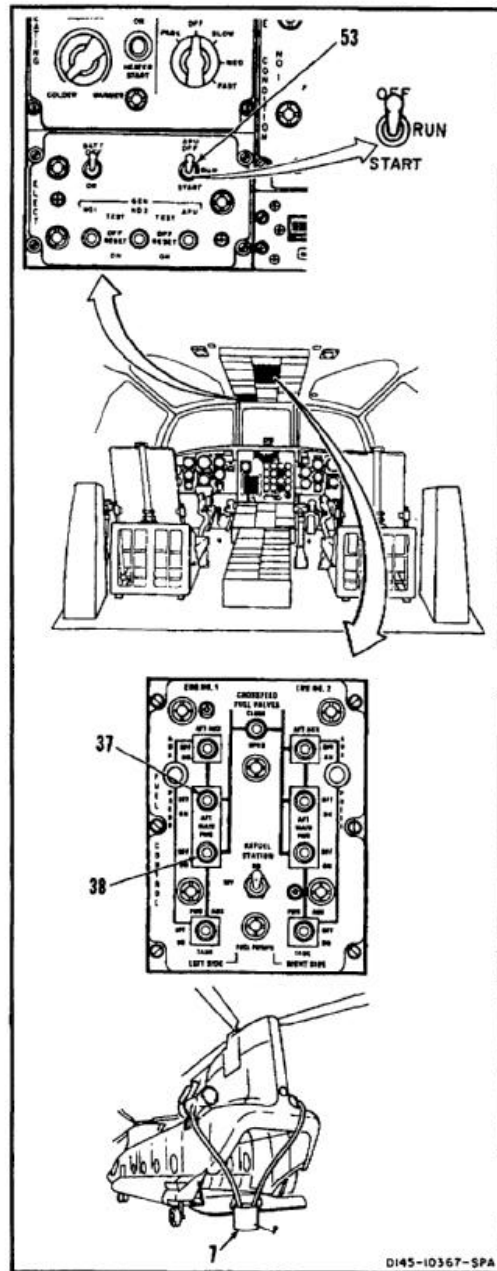

- 49. Disconnect drain hose (50) from valve (49).
- 50. Disconnect drain hose grounding wire (51) from helicopter ground point (52).
- 51. Remove drain hose (50) from vicinity of helicopter.
- 52. Connect fuel hose (48) to valve (49).

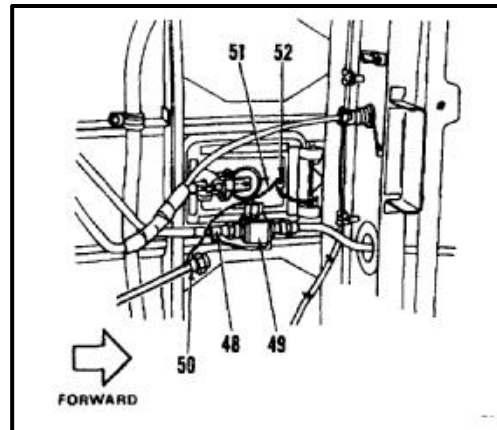

NOTE

Steps 53 thru 55 are without **74**.

- 53. Disconnect one drain hose (6) from fuel hose (3) on each engine (5).
- 54. Remove cap from fuel control nipple (4). Connect fuel hose (3) to nipple.
- 55. Disconnect grounding wire (8) on each drain hose (6).

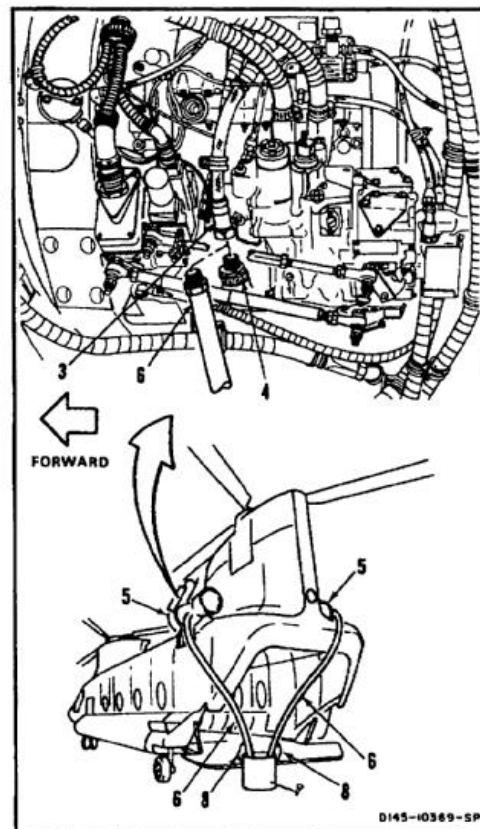

NOTE

Steps 56 thru 64 are with **74**.

56. Wearing gloves (E184.1), disconnect drain hose (11) from fuel hose (6) on each engine (9).
57. Remove cap from union (8). Connect fuel hose (6) to the union.
58. Clamp hose (6) to hose (7) with clamp (5), screws (3), and nut (4).
59. Disconnect grounding wire (10) on each drain hose (11).

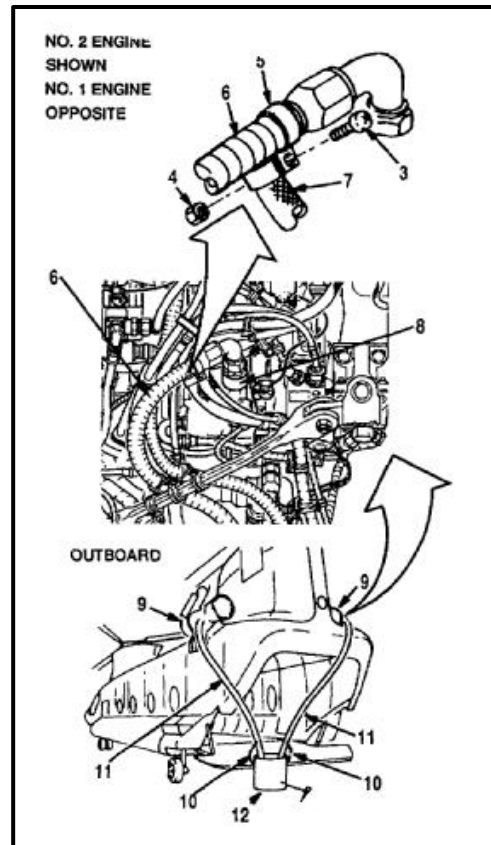

60. On No. 1 PDP panel (9) close (push in) FUEL SHUT OFF circuit breaker (21).

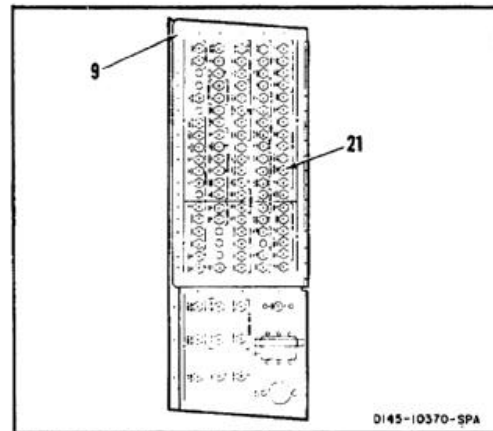

61. On No. 2 PDP panel (22) close (push in) FUEL SHUTOFF circuit breaker (31).

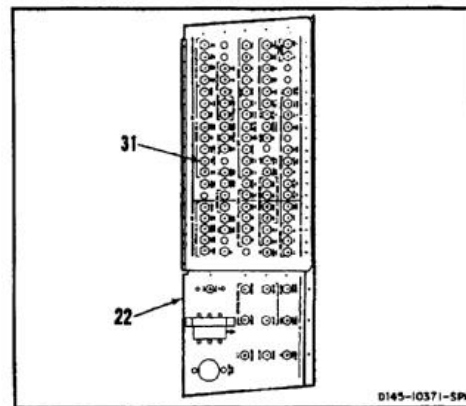

62. Set CROSSFEED FUEL VALVES switch (33) to CLOSE.
63. Pressurize utility hydraulic system.
64. Install new elements in both engine static fuel filter. (Refer to TM 55-2840-254-23 without **74**, TM 1-2840-265-23 with **74**.)
65. Remove ac power from helicopter.

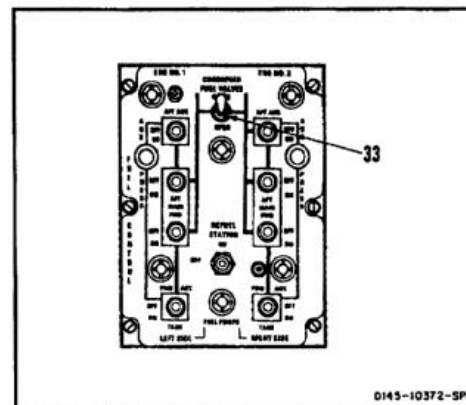

INSPECT

FOLLOW-ON MAINTENANCE:

- Close engine access cover (Task 4-50).
- Close engine work platform (Task 2-2).

END OF TASK

INITIAL SETUP**Applicable Configurations:**Without **74****Tools:**

Aircraft Mechanic's Tool Kit, NSN 5180-00-323-4692
 Drain Hoses (2), Approximately 16 Feet Long, One
 End to Have 5/8 Inch Standard Hose Flared Fitting
 Drain Hoses (2), Approximately 16 Feet Long One
 End to Have 3/8 Inch Standard Hose Flared Fitting
 Grounded Container, 50 Gallon or Equivalent

Materials:

Cloths (E135)
 Gloves (E184.1)

Personnel Required:

Medium Helicopter Repairer (2)
 Inspector

References:

Task 1-37
 Task 1-38
 TM 55-2840-254-23

Equipment Condition:

Battery Connected
 Electrical Power On
 Helicopter Grounded (Task 1-29)
 Helicopter Refueled (Task 1-51)
 Engine Work Platforms Open (Task 2-2)
 Engine Access Cover Open (Task 4-49)

General Safety Instructions:**WARNING**

All regulations and instructions
 for handling fuels shall be strictly
 observed.

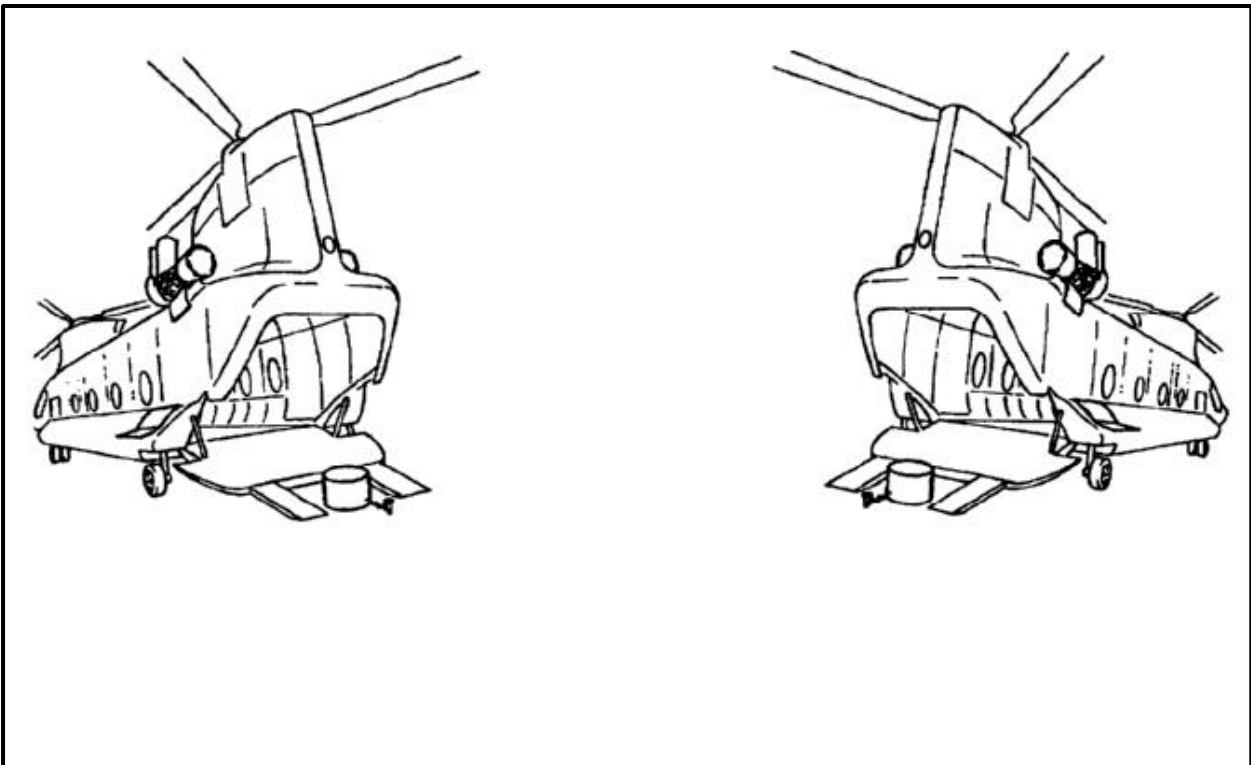

1. Remove and clean starting fuel hose (1) and starting fuel tube (2) on each engine (3 and 4) (TM 55-2840-254-23).
2. Install hose (1) on solenoid valve (5) on each engine (3 and 4) (TM 55-2840-254-23).
3. Connect drain hose (6) on hose nipple (7) on each engine (3 and 4).

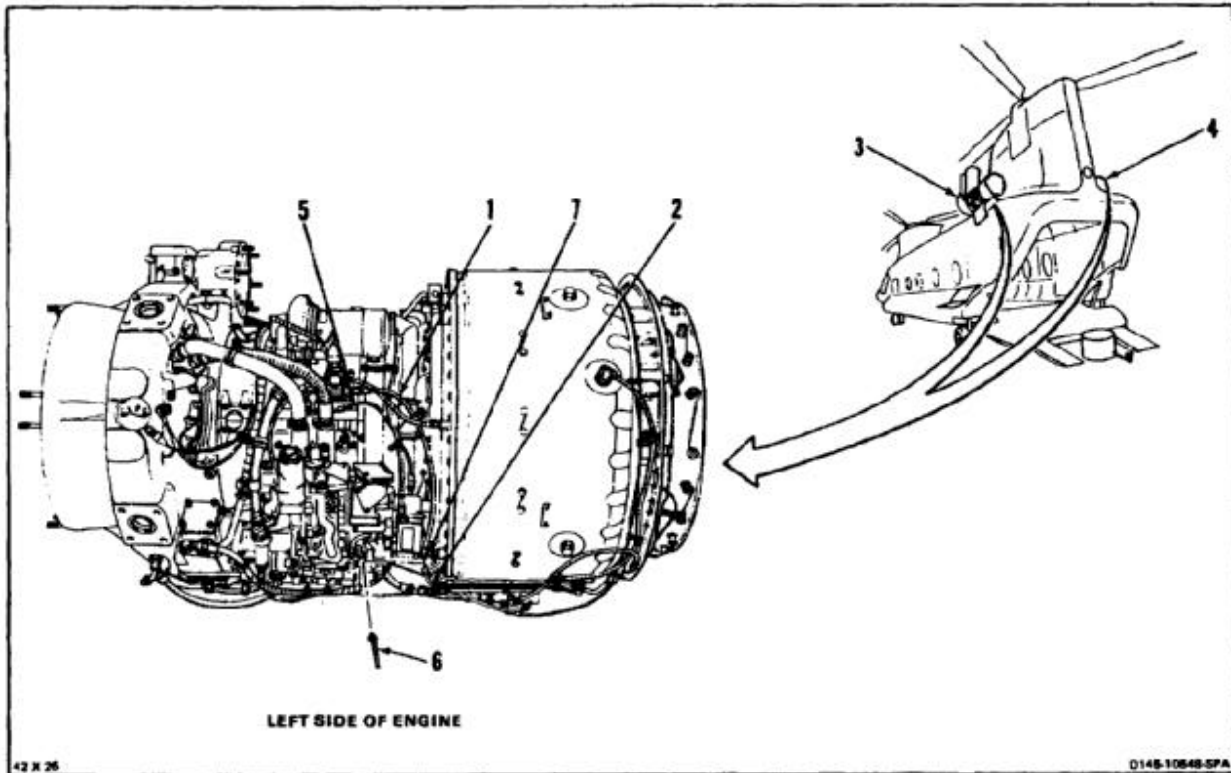

CAUTION

Do not use tape to seal open ports. Tape adhesive is soluble in fuel and can cause contamination.

4. Disconnect fuel hose (8) from flow divider nipple (9) on each engine (3 and 4). Cap nipples.
5. Connect one drain hose (10) to fuel hose (8) on each engine (3 and 4).

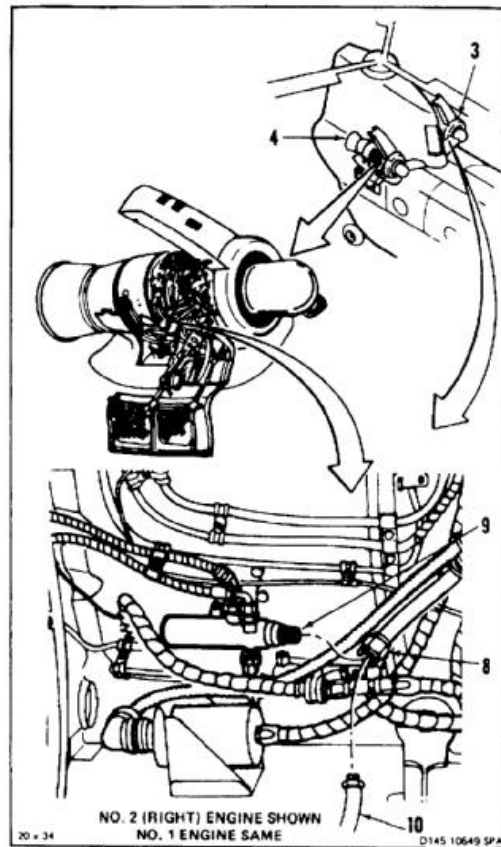

6. Place free end of each drain hose (6 and 10) in grounded container (11).
7. Attach grounding wires (12) on each drain hose (6 and 10) to grounded container (11).
8. Apply hydraulic power to helicopter (Task 1-38).

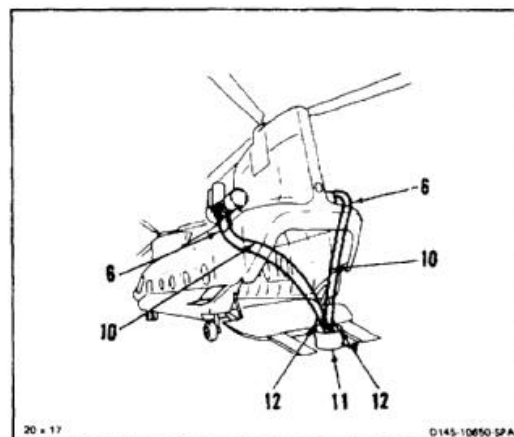

9. On PDP No. 1 (13), check that START & TEMP circuit breaker (14) is closed (pushed in).
10. On PDP No. 1 (13), open ENGINE No. 1 IGN circuit breaker (15).
11. On PDP No. 2 (16), check that following START & TEMP circuit breaker (17) is closed (pushed in).
12. On PDP No. 2 (16), open ENGINE No. 2 IGN circuit breaker (18).
13. Check ENGINE 1 START switch (19) and ENGINE 2 START switch (20) are OFF.
14. Check ENGINE CONDITION No. 1 lever (21) is at STOP.
15. Set ENGINE 1 START switch (19) to START.
16. Set ENGINE CONDITION No. 1 lever (21) to GROUND.
17. Allow approximately **15 gallons** of fuel to flow through drain hoses (6 and 10) into container (11).
18. Set ENGINE 1 START switch (19) to MOTOR.
19. Set ENGINE CONDITION No. 1 lever (21) to STOP.
20. Set ENGINE 1 START switch (19) to OFF.
21. Repeat steps 14 thru 19 for ENGINE 2.

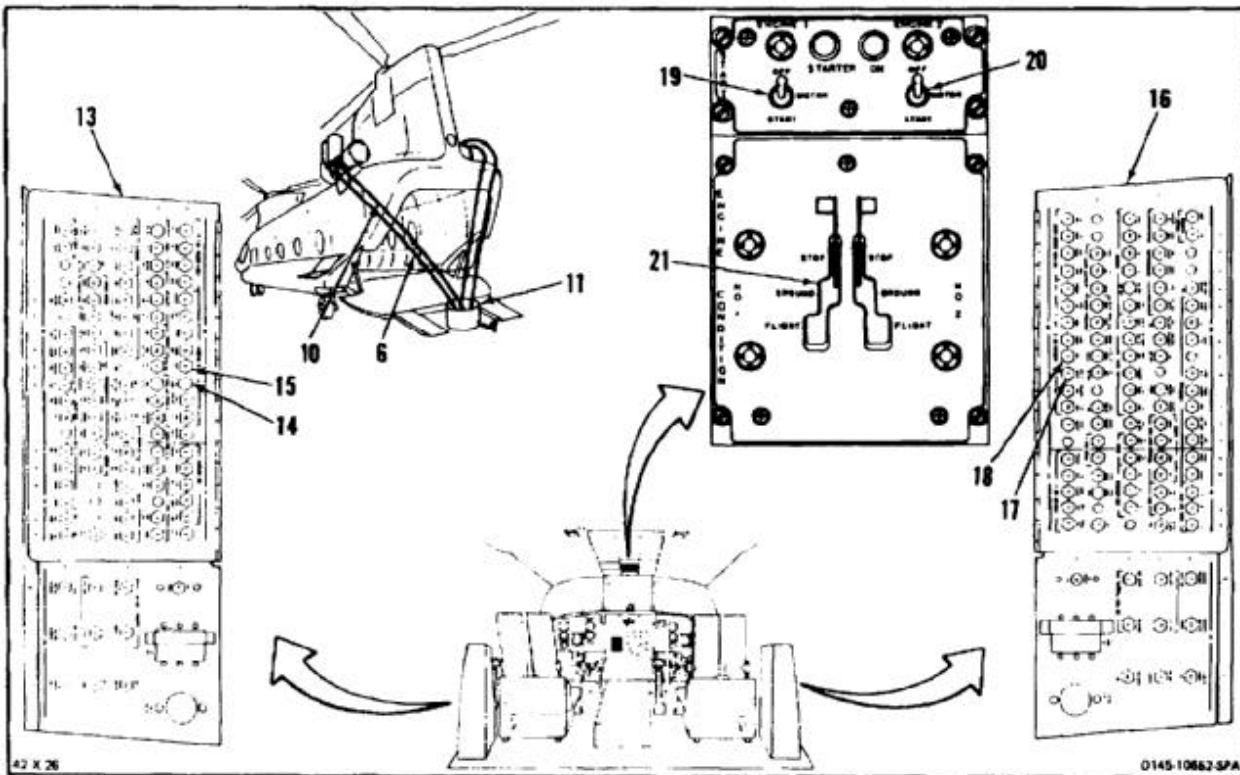

10-37 FLUSHING ENGINE FUEL SYSTEM (Continued)**10-37**

22. Remove ac electrical power and hydraulic power from helicopter (Tasks 1-37 and 1-38).
23. Disconnect drain line (10) from fuel hose (8) on each engine.
24. Remove cap from valve nipple (9). Install fuel hose (8) on nipple on each engine.

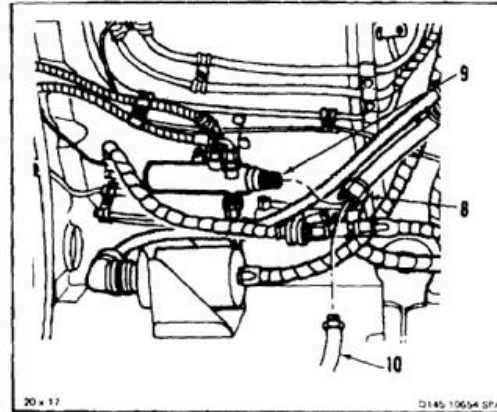

25. Disconnect drain line (6) from nipple (7) on each engine.
26. Install starting fuel tube (2) on each engine (TM 55-2840-254-23).

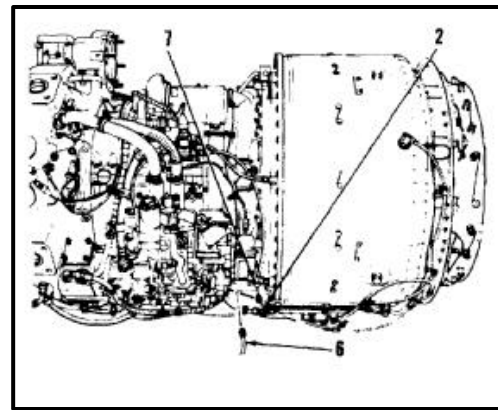

27. Disconnect four grounding wires (12) from grounded container (11).
28. Remove, clean and install fuel control unit filters on each engine (TM 55-2840-254-23).
29. Remove, clean and install element of in-line fuel filter on each engine (TM 55-2840-254-23).
30. Clean up any spilled fuel. Use cloths (E135).

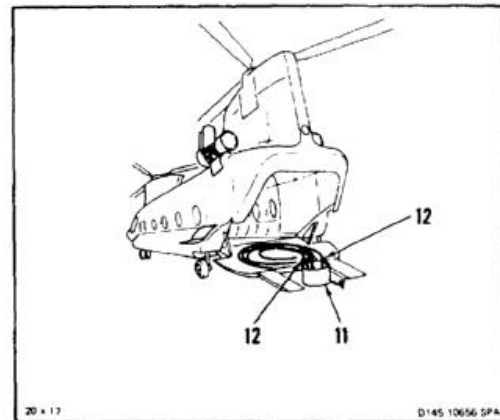
**INSPECT****FOLLOW-ON MAINTENANCE:**

- Close engine access cover (Task 4-50).
- Close engine work platform (Task 2-2).

END OF TASK

INITIAL SETUP

Applicable Configurations:

With **74**

Tools:

Aircraft Mechanic's Tool Kit, NSN 5180-00-323-4692
 Drain Hoses (2), Approximately 16 Feet Long, One
 End With 5/8 Inch Standard Hose Flared Fitting
 Drain Hoses (2), Approximately 16 Feet Long, One
 End With 3/8 Inch Standard Hose Flared Fitting
 Grounded Container, Fuel, 50 Gallon or Equivalent

Materials:

Cloths (E135)
 Gloves (E184.1)

Personnel Required:

Medium Helicopter Repairer (2)
 Inspector

References:

Task 1-37
 Task 1-38
 TM 1-2840-265-23

Equipment Condition:

Battery Connected
 Electrical Power On
 Helicopter Grounded (Task 1-29)
 Helicopter Refueled (Task 1-51)
 Engine Work Platforms Open (Task 2-2)
 Engine Access Cover Open (Task 4-49)

General Safety Instructions:**WARNING**

All regulations and instructions
 for handling fuels shall be strictly
 observed.

WARNING

Fuel is flammable and irritant to skin,
 eyes, and respiratory tract. Avoid
 repeated or prolonged skin contact.
 Handle only in well-ventilated areas.
 Keep away from sparks, open flames,
 or other sources of ignition.

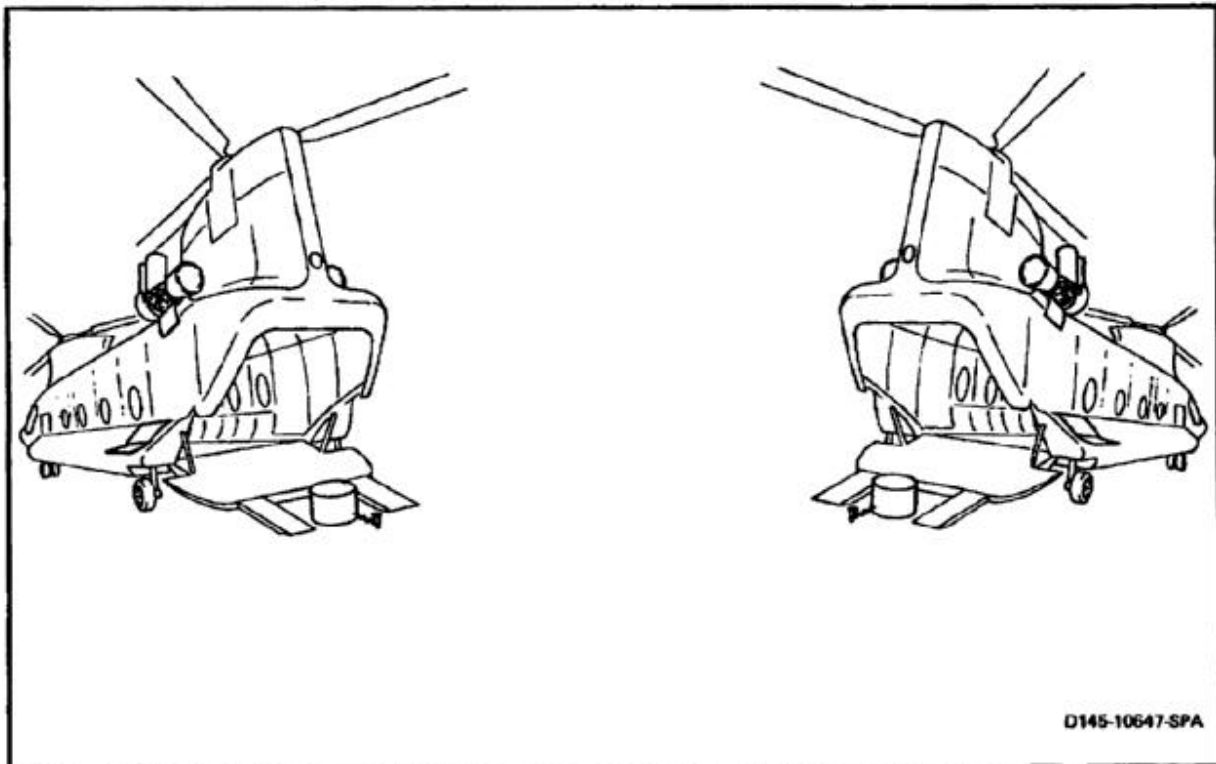

D145-10647-SPA

NOTE

Wear gloves (E184.1) when performing steps 1 thru 7.

1. Remove and clean starting fuel hose (1) and starting fuel tube (2) on each engine (3 and 4) (TM 1-2840-265-23).
2. Install hose (1) on solenoid valve (5) on each engine (3 and 4) (TM 1-2840-265-23).
3. Connect drain hose (6) to end of hose (1) on each engine (3 and 4).

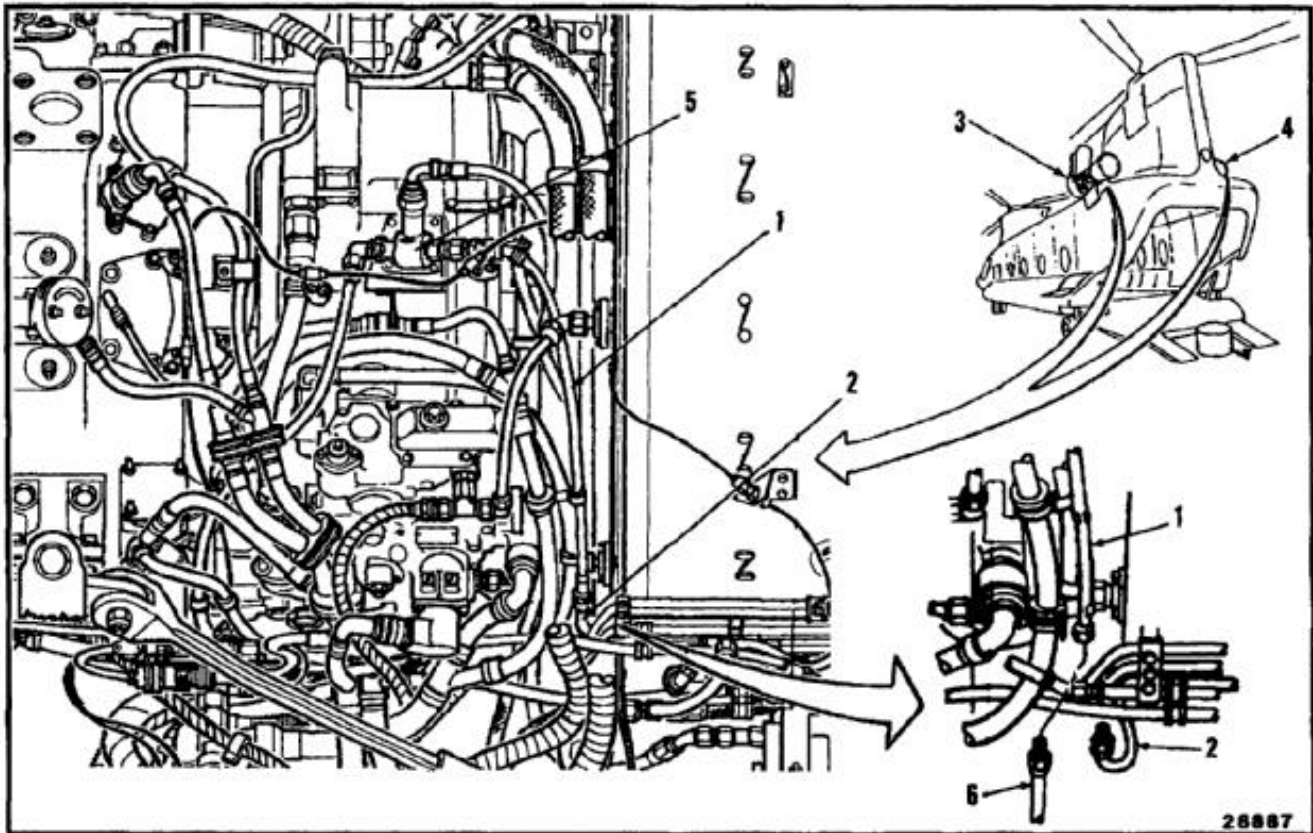

26887

CAUTION

Do not use tape to seal open ports.
Tape adhesive is soluble in fuel and can cause contamination.

4. Disconnect fuel hose (7) from flow divider (8) on each engine (3 and 4). Cap connectors.
5. Connect a drain hose (9) to fuel hose (7) on each engine (3 and 4).

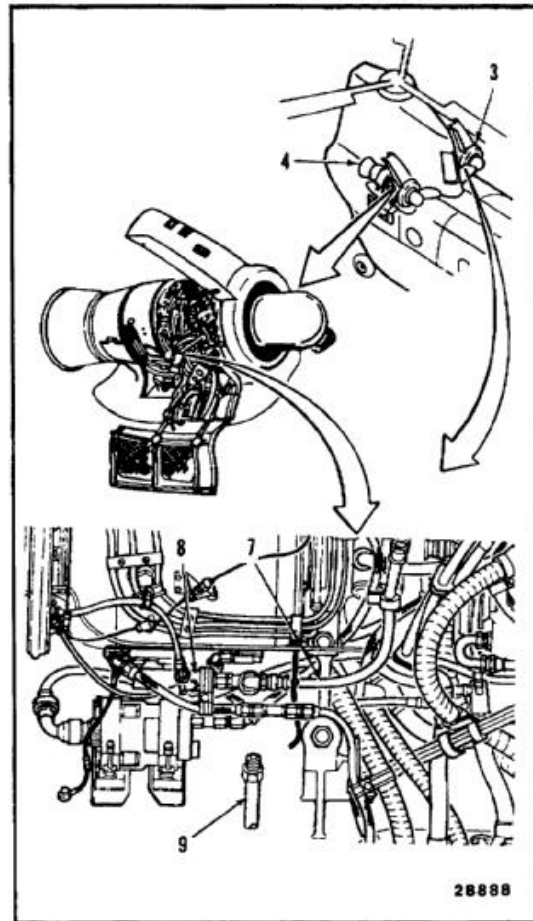

6. Attach ground wires (10) from each drain hose (6 and 9) to grounded container (11).
7. Place free end of each drain hose (6 and 9) in grounded container (11).
8. Apply hydraulic power to helicopter (Task 1-38).

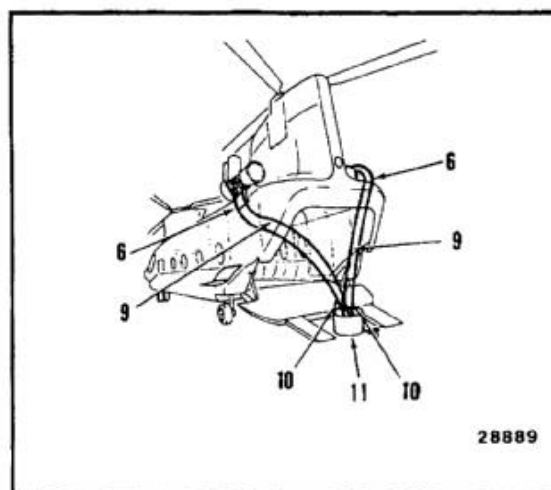

10-37.1 FLUSHING ENGINE FUEL SYSTEM (Continued)

10-37.1

9. On PDP No. 1 (12), open the ENGINE No. 1 START & IGN circuit breaker (13).
10. On PDP No. 2 (14), open ENGINE No. 2 START & IGN circuit breaker (15).
11. On FADEC panel (16), check that ENG START switch (17) is centered.
12. On ENGINE CONDITION panel (18), check that No. 1 lever (19) is at STOP.
13. Set ENG START switch (17) to 1.
14. Allow approximately **15 gallons** of fuel to flow through drain hoses (6 and 10) into container (11).
15. Center ENG START switch (17).
16. On ENGINE CONDITION panel (18), check that No. 2 lever (20) is at STOP.
17. Set ENG START switch (17) to 2.
18. Allow approximately **15 gallons** of fuel to flow through drain hoses (21 and 22) into container (11).
19. Center ENG START switch (17).
20. On PDP No. 1 (12), close the ENGINE No. 1 START & IGN circuit breaker (13).
21. On PDP No. 2 (14), close the ENGINE NO. 2 START & IGN circuit breaker (15).

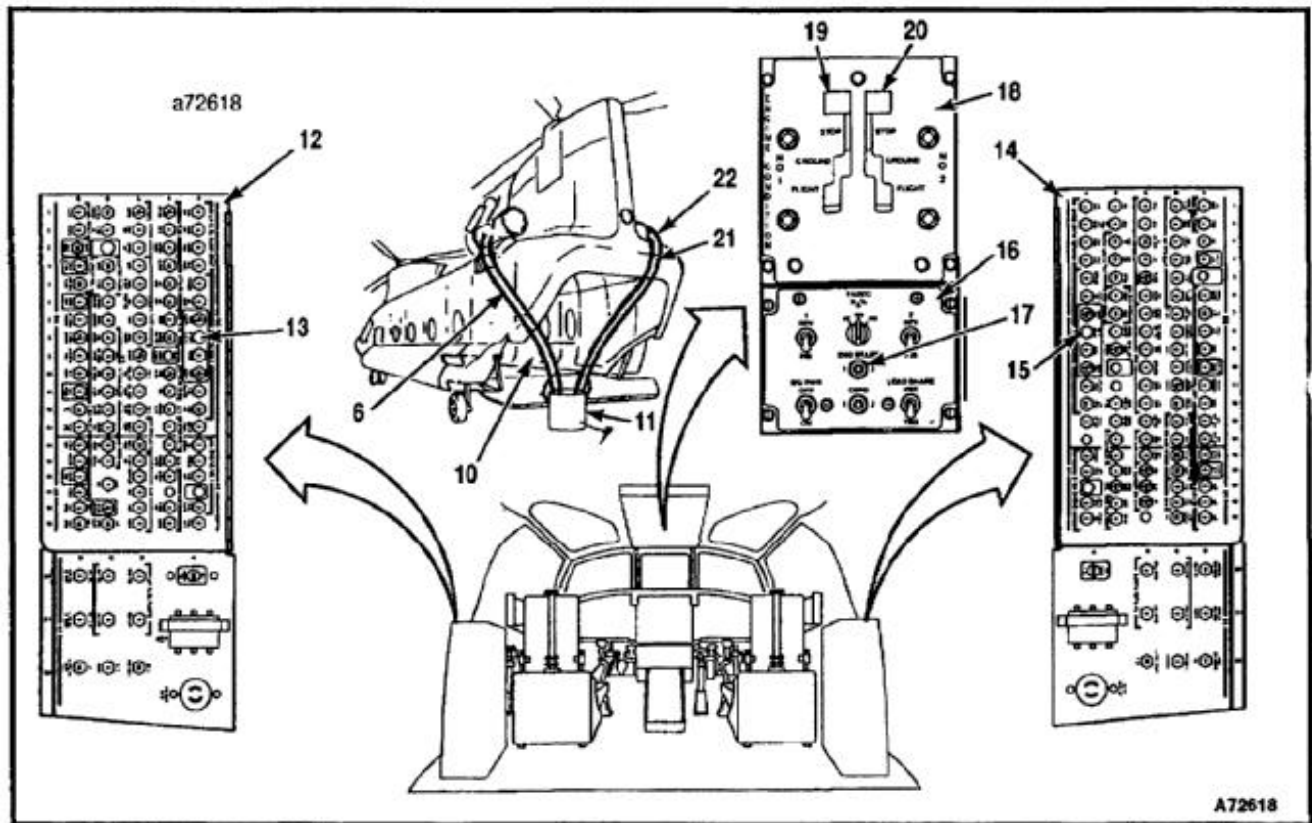

22. Remove ac electrical power and hydraulic power from helicopter (Tasks 1-37 and 1-38).

NOTE

Wear gloves (E184.1) when performing steps 23 thru 30.

23. Disconnect drain line (9) from fuel hose (7) on each engine.
24. Remove cap from flow divider (8). Install fuel hose (7) on flow divider of each engine.

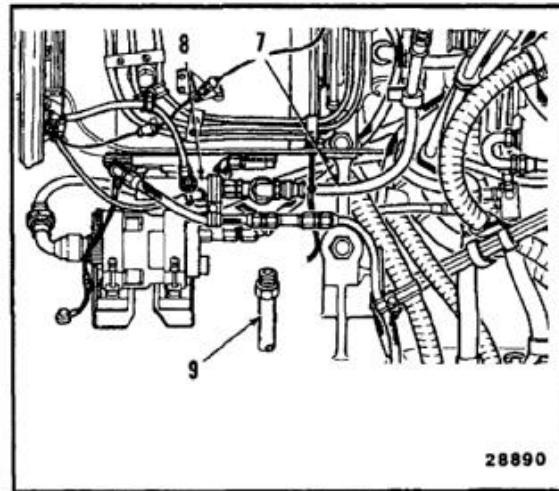

25. Disconnect drain hose (6) from end of hose (1) on each engine.
26. Install starting fuel tube (2) on each engine (TM 1-2840-265-23).

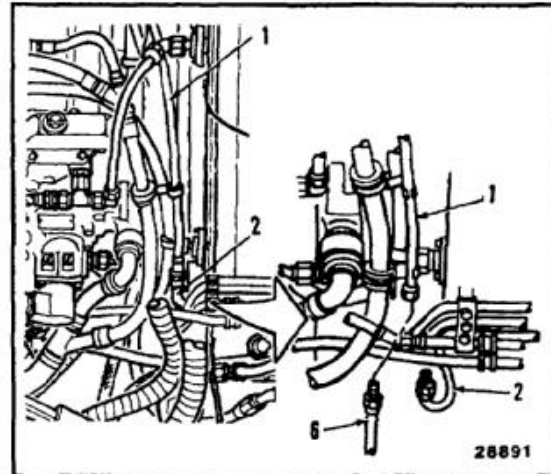

27. Disconnect four ground wires (10) from grounded container (11).
28. Remove, clean, and install barrier filter element on each engine (TM 1-2840-265-23).
29. Remove, clean, and install inline fuel filter element on each engine (TM 1-2840-265-23).
30. Wearing gloves (E184.1), clean up any spilled fuel. Use cloths (E135).

INSPECT**FOLLOW-ON MAINTENANCE:**

Close engine access cover (Task 4-50).
Close engine work platform (Task 2-2).

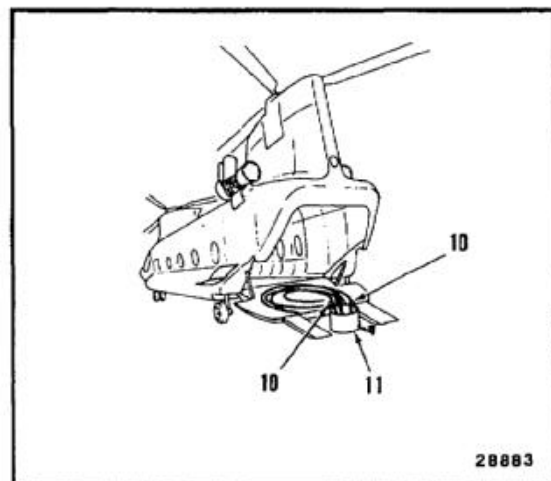

END OF TASK

INITIAL SETUP

Applicable Configurations:

All

Tools:

As Required

Materials:

As Required

Parts:

As Required

Personnel Required:Medium Helicopter Repairer (2)
Inspector**References:**

TM 1-1500-204-23

Equipment Condition:

As Required



Do not allow fittings at access doors to turn when connecting or disconnecting fuel hoses. Otherwise, access door fittings can fail and cause fuel or vent blockage.

1. Cap or plug open lines and fittings to prevent foreign matter entering the fuel system.
2. Replace standard parts with like, serviceable parts as required.
3. Use new gaskets or packings when reinstalling fittings.

4. Install preformed aluminum seals VSF1015A16B in hose connections. Torque connectors to **500-700 inch-pounds**.
5. After installation, check the connections of replaced parts for leaks.
6. Where tubing emerges through outer skin of fuselage, replace watertight seal as required.
7. Repair, fabricate, and test fuel lines as directed in TM 1-1500-204-23.

FOLLOW-ON MAINTENANCE:

As Required

END OF TASK

INITIAL SETUP

Applicable Configurations:

All

Tools:

Aircraft Mechanic's Tool Kit, NSN 5180-00-323-4692
 Socket, 1 Inch
 Grounded Container, 14 Quart or Equivalent

Materials:

Cloths (E135)

Personnel Required:

Medium Helicopter Repairer

Equipment Condition:

Battery Disconnected (Task 1-39)
 Electrical Power Off
 Helicopter Grounded (Task 1-29)
 Tank Defueled Aft Aux Main or Fwd Aux, As Required
 (Task 10-34 or 10-35)

General Safety Instructions:**WARNING**

All regulations and instructions
 for handling fuels shall be strictly
 observed.

NOTE

There are two drain valves on each
 tank, one at forward end and one at
 aft end. Procedure can be used to
 remove any drain valve.

Forward and aft drain valves on each
 tank do not look alike.

1. For forward location in tank, remove drain valve (1) and packing (2). Install plug in port (3). Use container for spilled fuel.
2. For aft location in tank, remove drain valve (4) and packings (5 and 6). Install plug in port (7). Use container for spilled fuel.
3. Clean up spilled fuel. Use cloths (E135).

FOLLOW-ON MAINTENANCE:

None

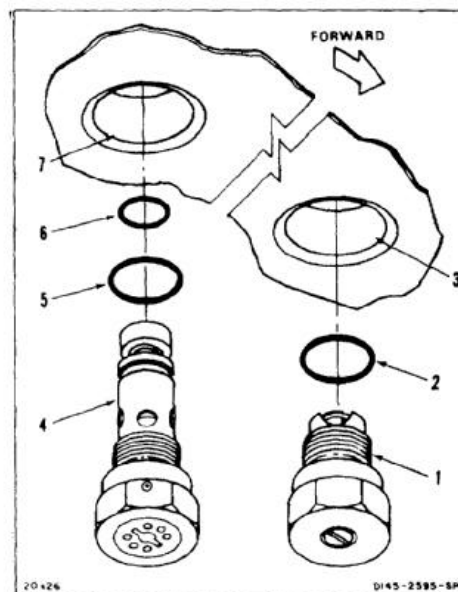
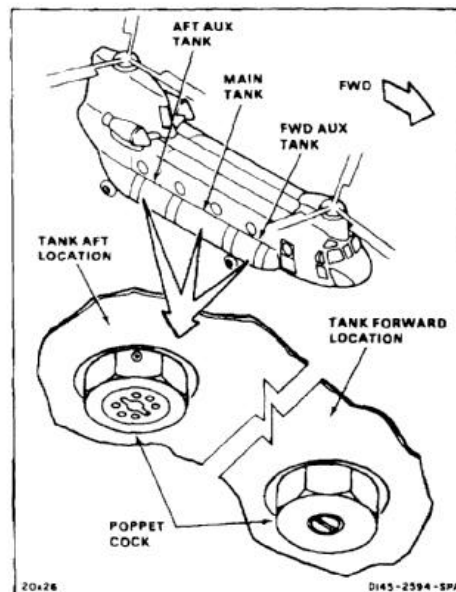

END OF TASK

10-204

INITIAL SETUP

Applicable Configurations:

All

Tools:

Aircraft Mechanic's Tool Kit, NSN 5180-00-323-4692
 Socket, 1 Inch
 Torque Wrench, 150 to 750 Inch-Pounds

Materials:

None

Parts:

Packings

Personnel Required:

Medium Helicopter Repairer
 Inspector

References:

TM 55-1520-240-23P

General Safety Instructions:**WARNING**

All regulations and instructions for handling fuels shall be strictly observed.

NOTE

There are two drain valves on each tank, one at forward end and one at aft end. Procedure can be used to install any drain valve.

Forward and aft drain valves do not look alike.

1. Remove plugs from tank drain holes (1) as required.
2. For aft location in tank, install packings (2 and 3) on drain cock (4). Install drain valve in aft drain hole (1). Torque valve to **180 to 240 inch-pounds**.
3. For forward location in tank, install packing (5) on drain cock (6). Install drain valve in forward drain hole (1). Torque valve to **180 to 240 inch-pounds**.

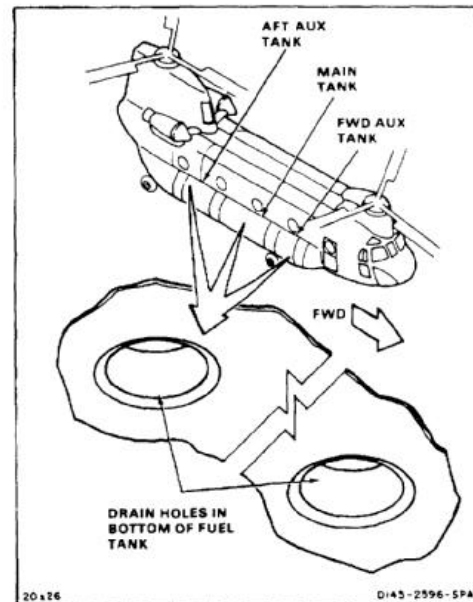

20x26

D145-2596-SPA

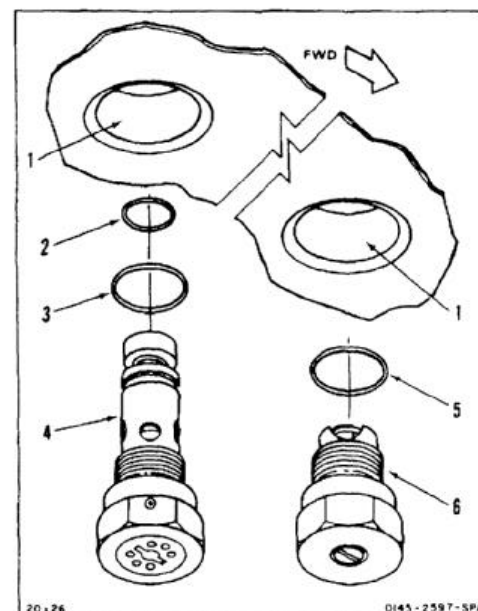

20x26

D145-2597-SPA

INSPECT

FOLLOW-ON MAINTENANCE:

Refuel affected tank(s) only.
Check for leaks.

END OF TASK

10-206

INITIAL SETUP

Applicable Configurations:

All

Tools:

Aircraft Mechanic's Tool Kit, NSN 5180-00-323-4692

Materials:

- Barrier Material (E80)
- Tape (E388)
- Paper Tags (E264)

Personnel Required:

Medium Helicopter Repairer

Equipment Condition:

- Battery Disconnected (Task 1-39)
- Electrical Power Off

- Helicopter Grounded (Task 1-29)
- Affected Side of Helicopter Defueled (Task 10-34 or 10-35)
- Forward Auxillary Tank Lowered on Hinges (Task 10-23)
- Main Fuel Tank Forward Boost Pump Removed (Task 10-51)
- Main Fuel Tank Aft Boost Pump Removed (Task 10-53)
- Main Fuel Tank — Fuel Quantity Transmitters Removed (Task 8-81)

General Safety Instructions:

WARNING

All regulations and instructions for handling fuel shall be strictly observed.

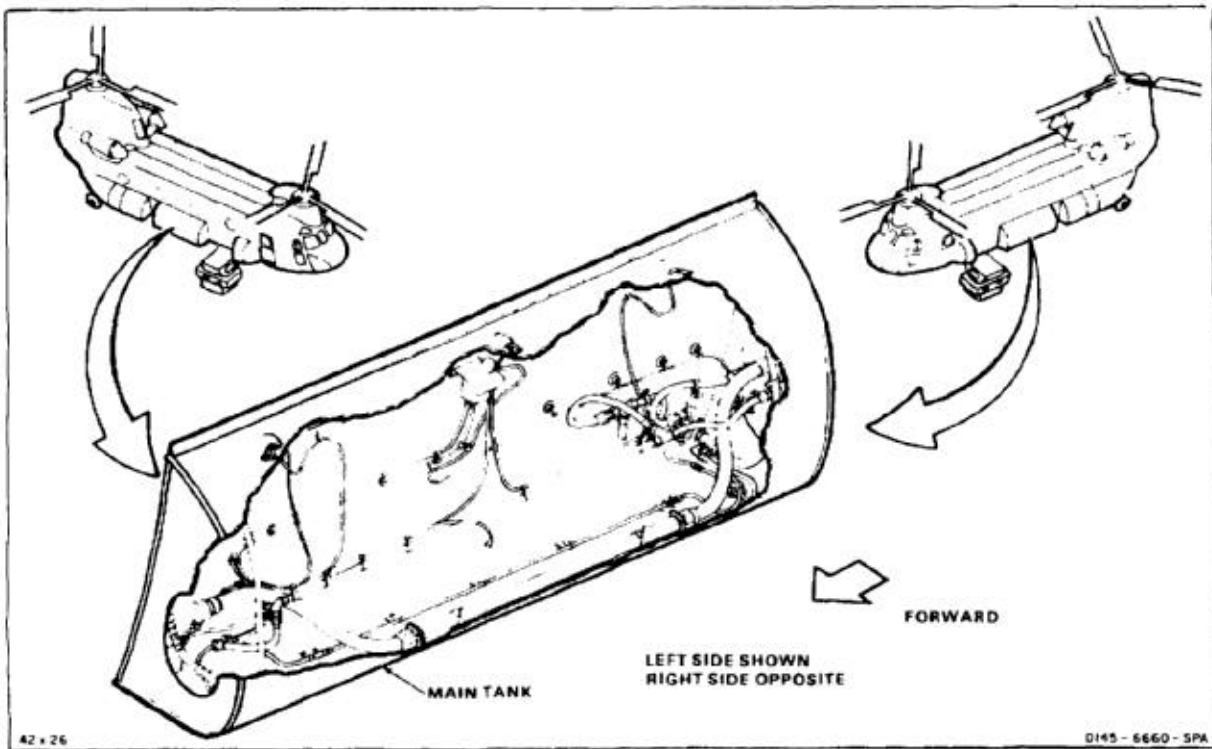

NOTE

Procedure is same to remove No. 1 or No. 2 main tank fuel lines and electrical wiring. No. 1 (left) main tank is shown here.

1. Disconnect hose connector (1).
2. Remove two screws (2), washers (3), and spacers (4).
3. Tag and remove tube (5), two clamps (6), tee (7), hose (8), tube (9), suction valve assembly (10), and cable clip (11) as unit. Plug tube and cap hose.

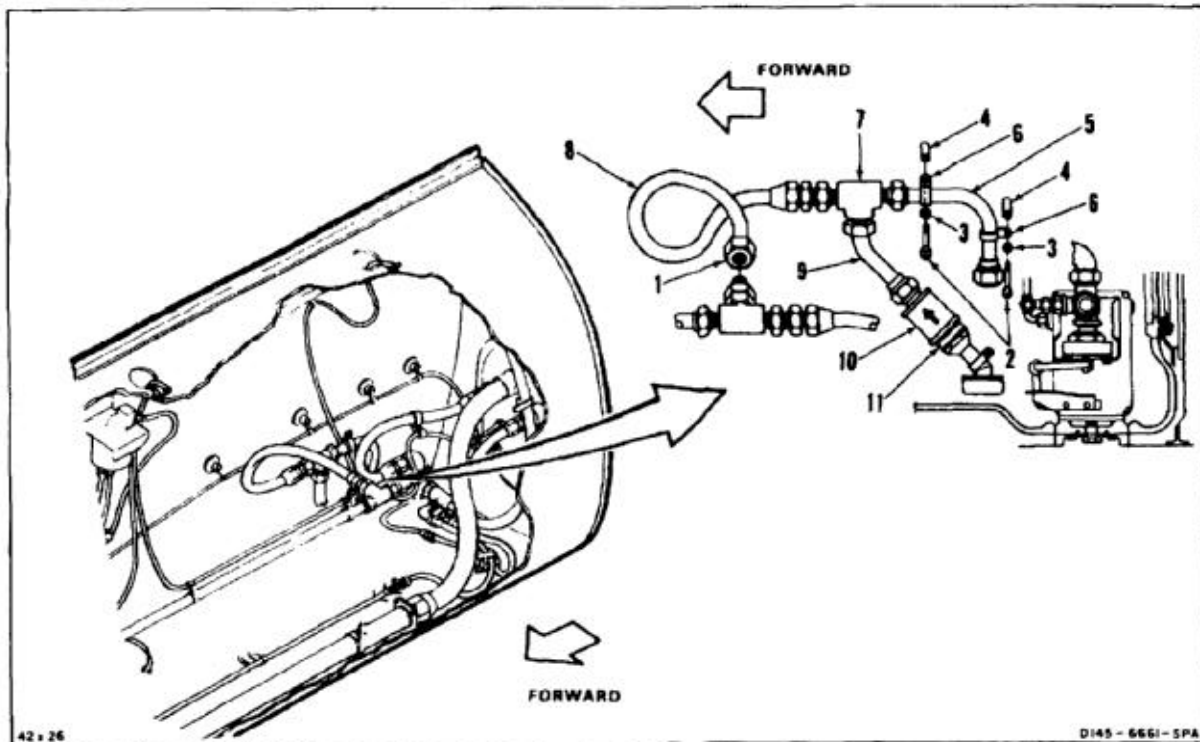

10-41 REMOVE MAIN TANK FUEL LINES AND ELECTRICAL WIRING (Continued)**10-41**

4. Remove two screws (12), washers (13), and spacers (14).
5. Tag and remove tube (15) and two hose (16) as a unit. Plug hoses.
6. Remove screw (17), washer (18), and nut (19).
7. Remove four screws (20) and washers (21).
8. Disconnect electrical connector (22).
9. Remove nut (23), washer (24), and screw (25).
10. Tag and remove electrical cable (26).

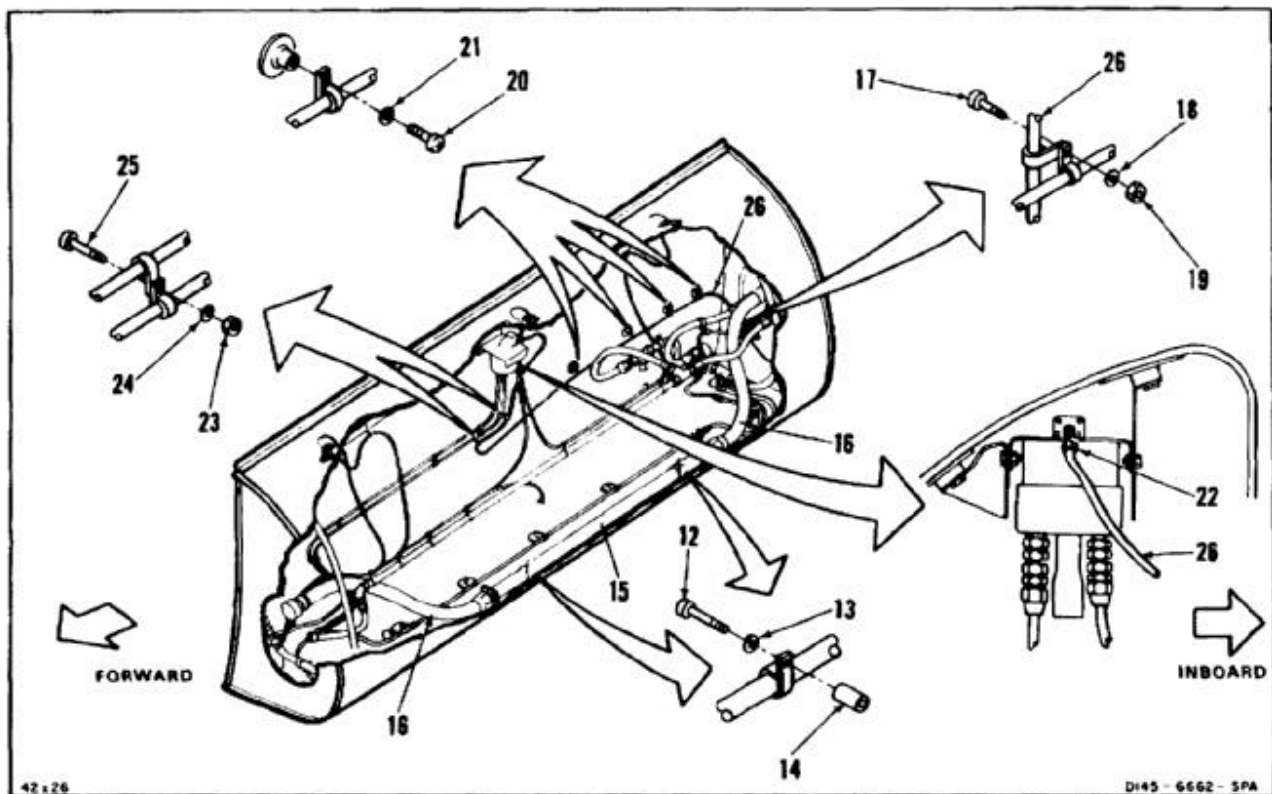

11. Disconnect two hose connectors (27).
12. Remove three screws (28) and washers (29).
13. Remove screw (30), washer (31), and spacer (32).
14. Tag and remove two hoses (33) as a unit.
15. Remove four screws (34) and washers (35).
16. Tag and remove tube (36) and electrical wire (37) as a unit.
17. Cover forward access hole (38) and aft access hole (39). Use barrier material (E80) and tape (E388).

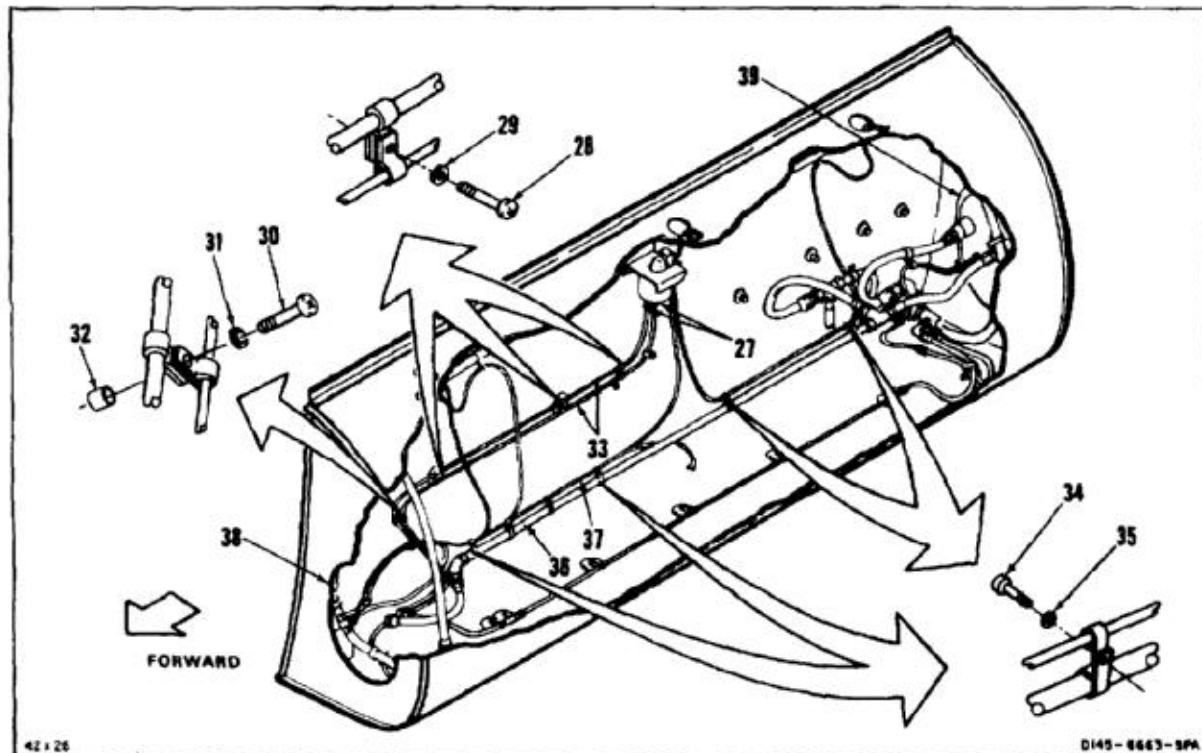
**FOLLOW-ON MAINTENANCE:**

None

END OF TASK

10-210

INITIAL SETUP**Applicable Configurations:**

All

Tools:

Aircraft Mechanic's Tool Kit, NSN 5180-00-323-4692

Materials:

Lockwire (E233)
Dry Cleaning Solvent (E162)
Cloths (E135)
Gloves (E186)

Personnel Required:

Medium Helicopter Repairer
Inspector

References:

TM 55-1520-240-23P

General Safety Instructions:**WARNING**

All regulations and instructions
for handling fuels shall be strictly
observed.

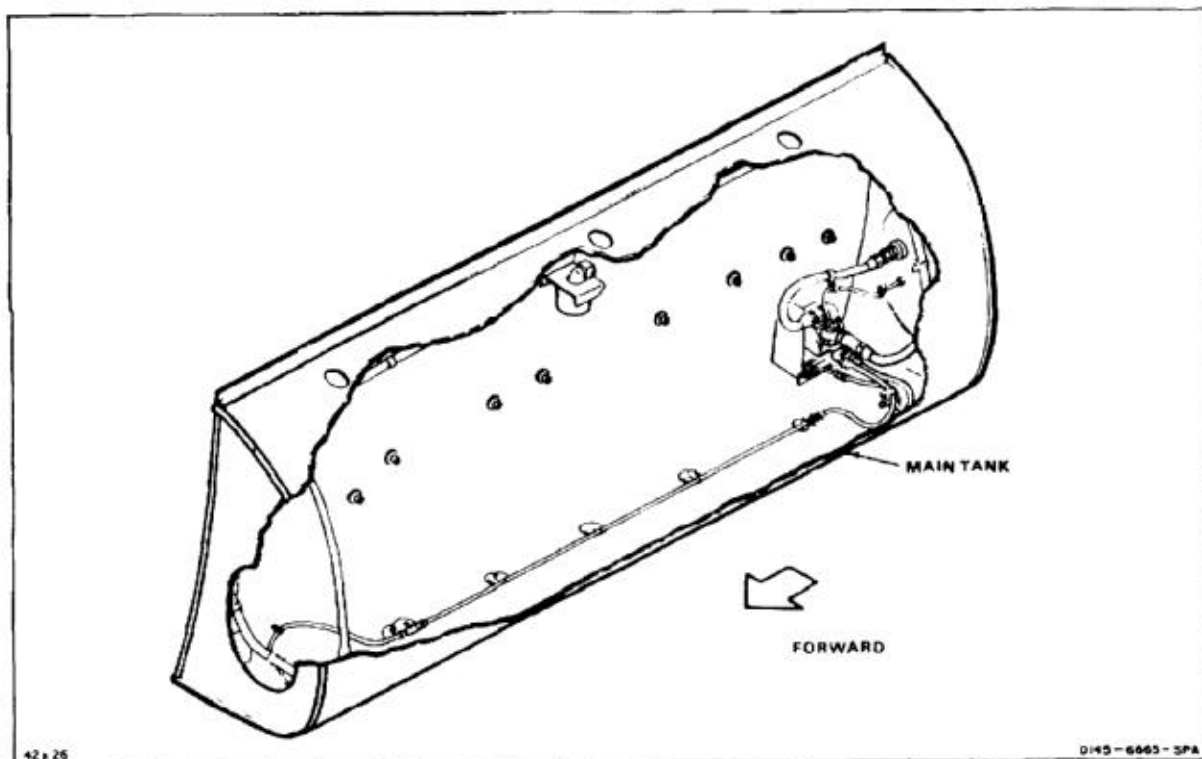

WARNING

Dry cleaning solvent (E162) is flammable and toxic. It can irritate skin and cause burns. Use only in well-ventilated area, away from heat and open flame. In case of contact, immediately flush skin or eyes with water for at least **15 minutes**. Get medical attention for eyes.

NOTE

Procedure is same to install No. 1 or No. 2 main tank fuel lines and electrical wiring. No. 1 (left) main tank is shown here.

1. Remove barrier material and tape from forward access hole (1) and aft access hole (2). Clean any tape residue from face of tank. Use dry cleaning solvent (E162) and cloths (E135). Use goggles for eyes. Wear gloves (E186).
2. Remove tags and position tube (3) and attached electrical wires (4) in fuel tank (5). Position four electrical wire clamps (6) and four tube clamps (7) against four tank attachment hoses (8).
3. Install four washers (9) and screws (10).
4. Remove tags and position two hoses (11) in fuel tank (5). Position three hose clamps (12) and three hose clamps (13) against three tank attachment hoses (14).
5. Install three washers (15) and screws (16).
6. Position two hose clamps (17 and 18) and spacer (19) against tank attachment hose (20).
7. Install washer (21) and screw (22).
8. Connect two hose connectors (23).

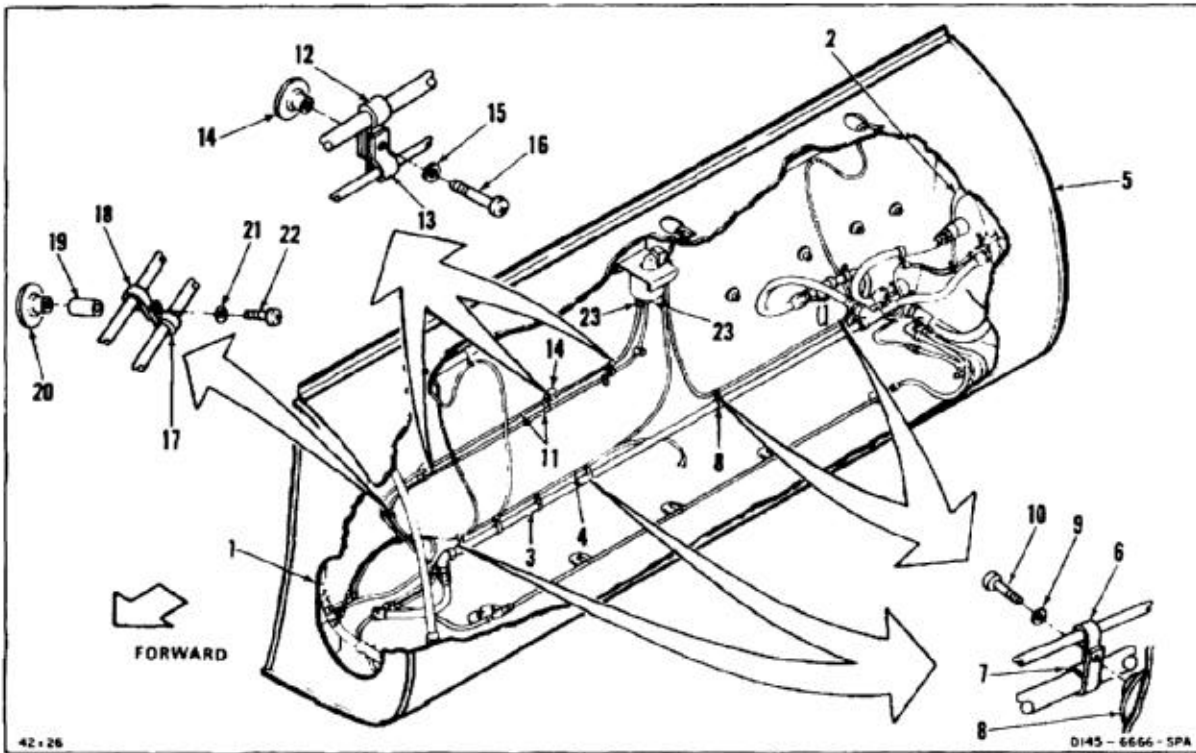

10-42 INSTALL MAIN TANK FUEL LINES AND ELECTRICAL WIRING (Continued)

- | | |
|--|--|
| <p>9. Position electrical cable (24) in fuel tank (5). Remove tags.</p> <p>10. Position two cable clamps (25) and two hose clamps (26).</p> <p>11. Install two screws (27), washers (28), and nuts (29).</p> <p>12. Connect electrical connector (30).</p> | <p>13. Position cable clamps (31) at four tank attachment points (32). Install four screws (33) and washers (34).</p> <p>14. Position cable clamps (35 and 35). Install screw (37), washer (38), and nut (39).</p> <p>15. Remove tags and position tube (40) and two hoses (41 and 42). Position tube clamps (43) at two tank attachment points (44). Install two spacers (45), washers (46), and screws (47).</p> |
|--|--|

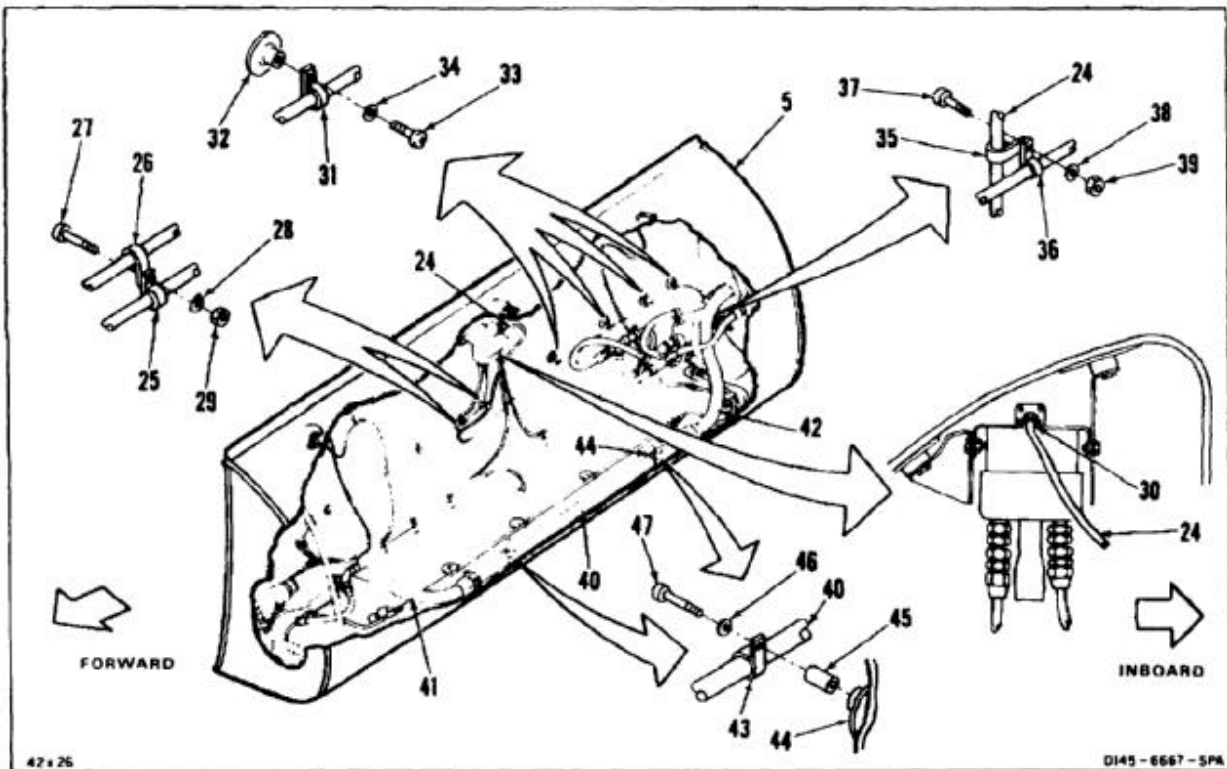

16. Remove tags and position tube (48), two clamps (49), tee (50), hose (51), tube (52), suction valve assembly (53), and cable clip (54) as a unit.
17. Install two spacers (55), washers (56), and screws (57).
18. Connect hose connector (58).

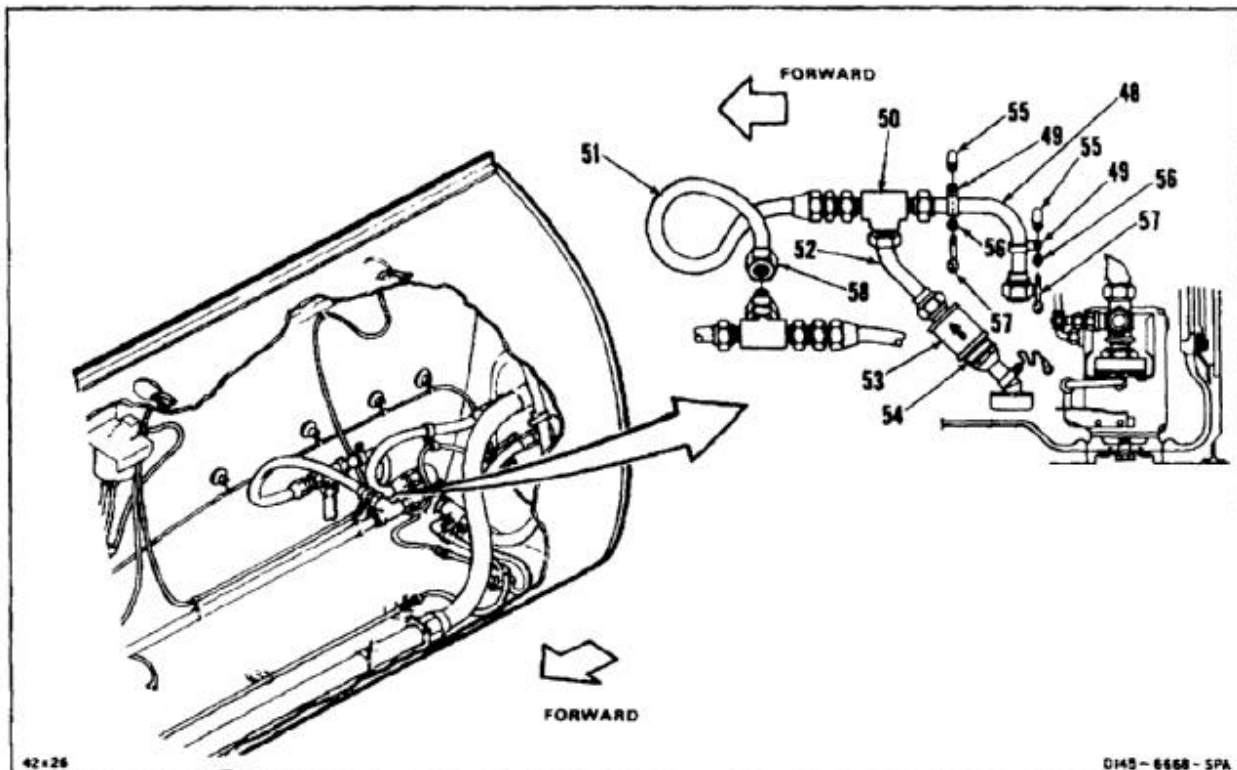
INSPECT**FOLLOW-ON MAINTENANCE:**

- Install main fuel tank-fuel quantity transmitters (Task 8-82).
- Install main fuel tank aft boost pump (Task 10-54).
- Install main fuel tank forward boost pump (Task 10-52).
- Raise and install forward auxiliary fuel tank (Task 10-26).
- Perform vent system pressure test (Task 10-117) on affected tank.
- Perform test of pressure refueling system (Task 10-119) and fuel feed system (Task 10-120).
- Refuel helicopter (Task 1-51).
- Bleed fuel system (Task 10-121).
- Perform operational check of affected fuel system (TM 55-1520-240-T).
- Inspect for leaks (Task 10-4).

END OF TASK

10-214

INITIAL SETUP

Applicable Configurations:

All

Tools:

Aircraft Mechanic's Tool Kit, NSN 5180-00-323-4692

Materials:

- Barrier Material (E80)
- Tape (E388)
- Paper Tags (E264)

Personnel Required:

Medium Helicopter Repairer

Equipment Condition:

- Battery Disconnected (Task 1-39)
- Electrical Power Off

- Helicopter Grounded (Task 1-29)
- Affected Side of Helicopter Defueled (Task 10-34 or 10-35)
- Forward Auxiliary Tank Lowered on Hinges (Task 10-23)
- Main Fuel Tank Forward Access Door Removed (Task 10-51)
- Main Fuel Tank Aft Access Door Removed (Task 10-53)
- Main Fuel Tank — Fuel Quantity Transmitters Removed (Task 8-81)

General Safety Instructions:

WARNING

All regulations and instructions for handling fuel shall be strictly observed.

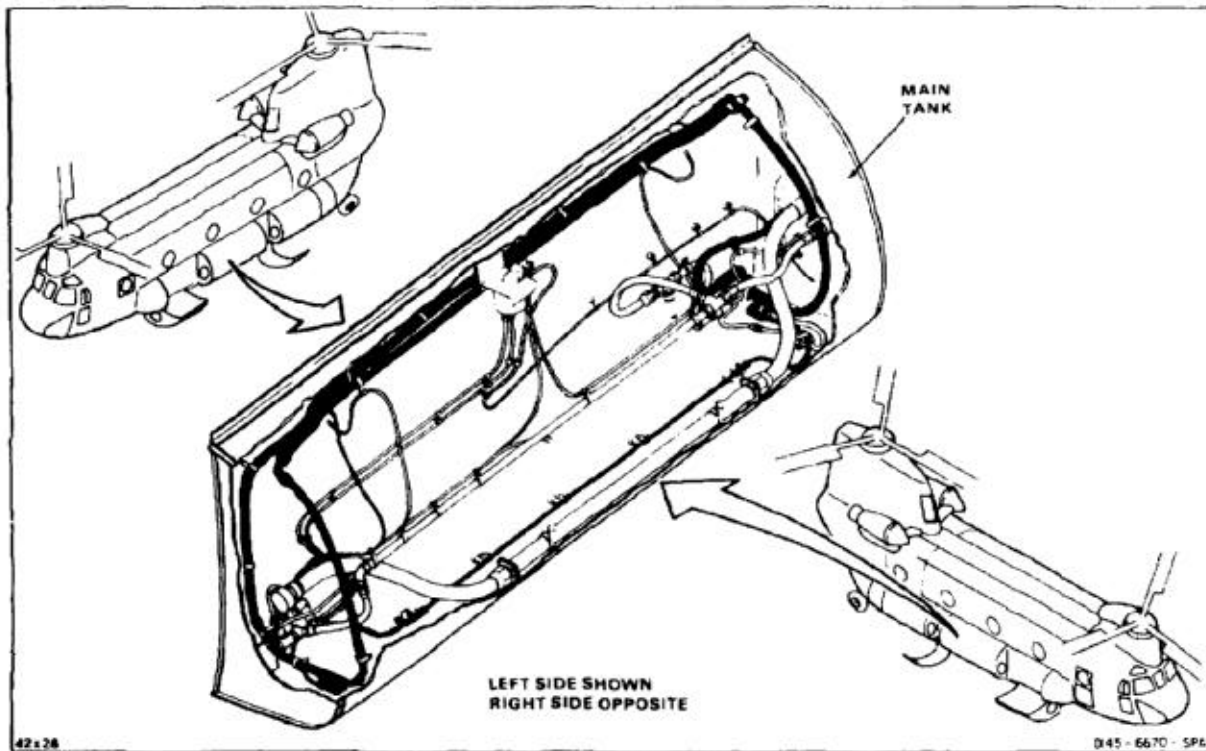

NOTE

Procedure is same to remove No. 1 or No. 2 main fuel tank vent assembly. Removal of No. 1 (left) vent assembly is shown here.

1. Disconnect hoses (1 and 2) from tee (3). Plug hoses and cap tee.
2. Disconnect hose (4) from drain valve (5). Tag and remove hose. Plug hose and cap valve.
3. Remove two screws (6) and washers (7) securing clamps (8) to tank cell (9).
4. Remove screw (10), washer (11), and nut (12) only if vent tube (13) will be removed from vent (14).
5. Disconnect hose (1) from vent tube (13). Tag and remove hose. Plug hose and cap tube.
- 5.1. If required, remove and plug tube (13).

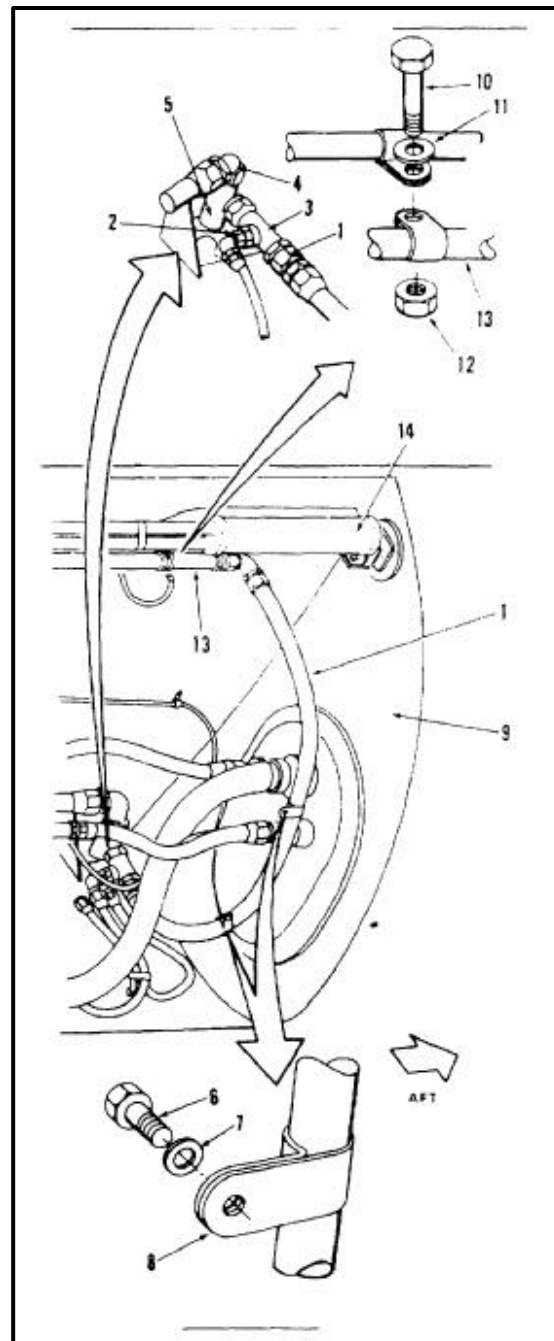

10-43 REMOVE MAIN FUEL TANK VENT ASSEMBLY (Continued)**10-43**

6. Remove six bolts (15), washers (16), and spacers (17).
7. Remove bolt (18), washer (19), and nut (20) securing clamp (21) on hose (22) to clamp (23) on tee (24).
8. Remove bolt (25) and washer (26).
9. Remove bolt (27), washer (28), and nut (29).

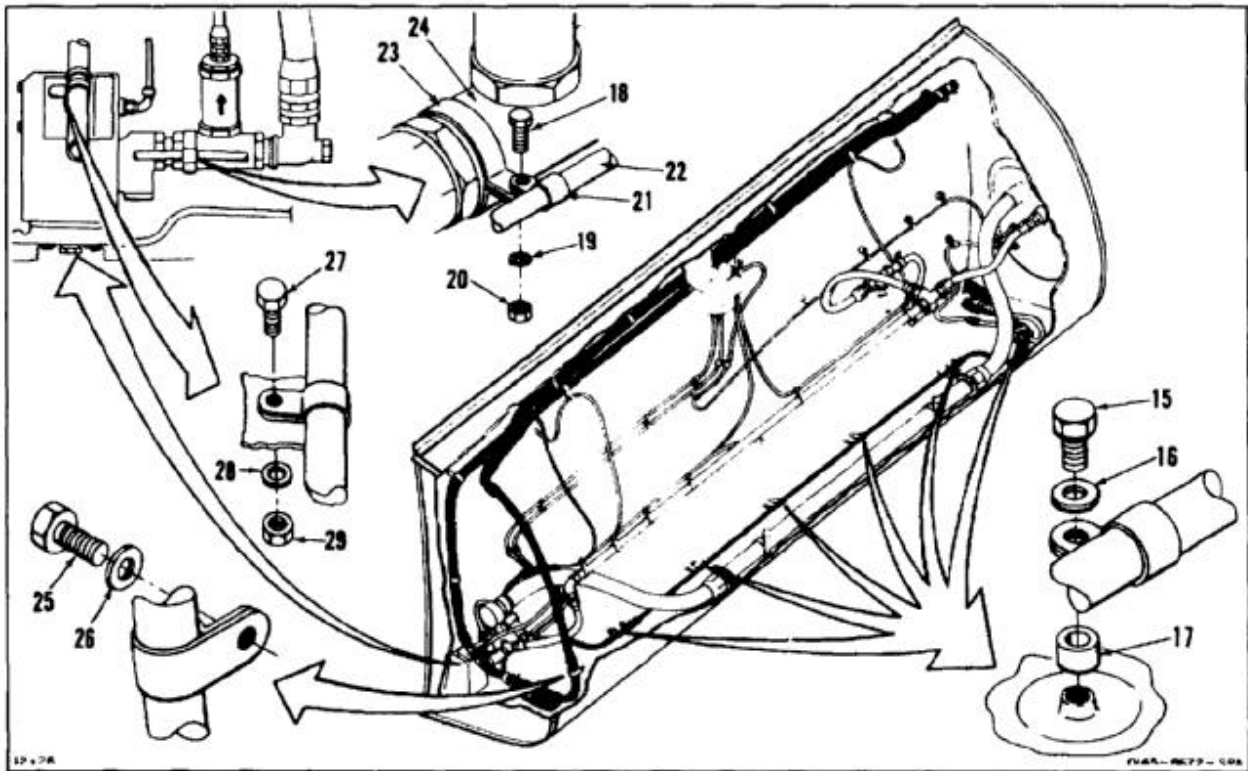

10. Remove nut (30), washer (31), and screw (32).
11. Disconnect hose (33). Plug hose.
12. Tag and remove tube (34) and hose assembly (33) from fuel tank (35) through forward access (36).
13. Disconnect hose connector (37).
14. Remove two screws (38) and washers (39).
15. Disconnect hose connector (40). Tag, remove, and plug hose (41).
16. Disconnect hose connectors (42 and 43). Tag and remove hose (44) and tube (45). Plug and cap hose and tube.

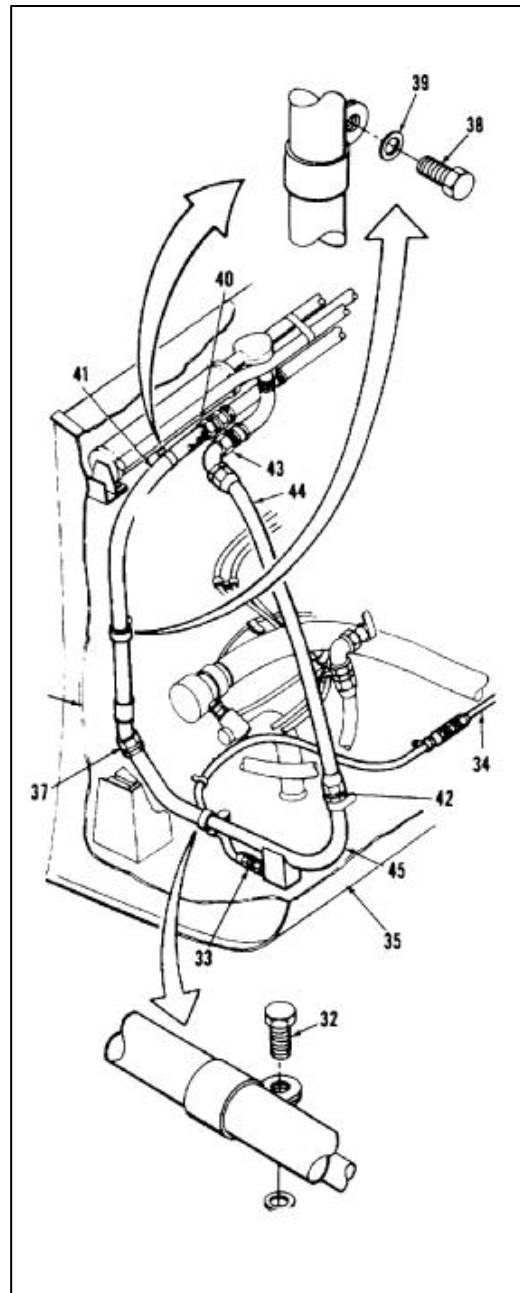

10-43 REMOVE MAIN FUEL TANK VENT ASSEMBLY (Continued)**10-43**

17. Remove two nuts (46), washers (47), and screws (48).
18. Remove nut (49), washer (50), spacer tube (51), and screw (52).
19. Remove screw (53) washer (54), and spacer (54.1).
20. Remove four nuts (55), washers (56), and screws (57). Two at forward end, and two at aft end.
21. Remove vent assembly (58) from fuel tank, through forward access (36). Plug and cap all openings in vent assembly.
22. Cover forward access hole (36) and aft access hole (37). Use barrier material (E80) and tape (E388).

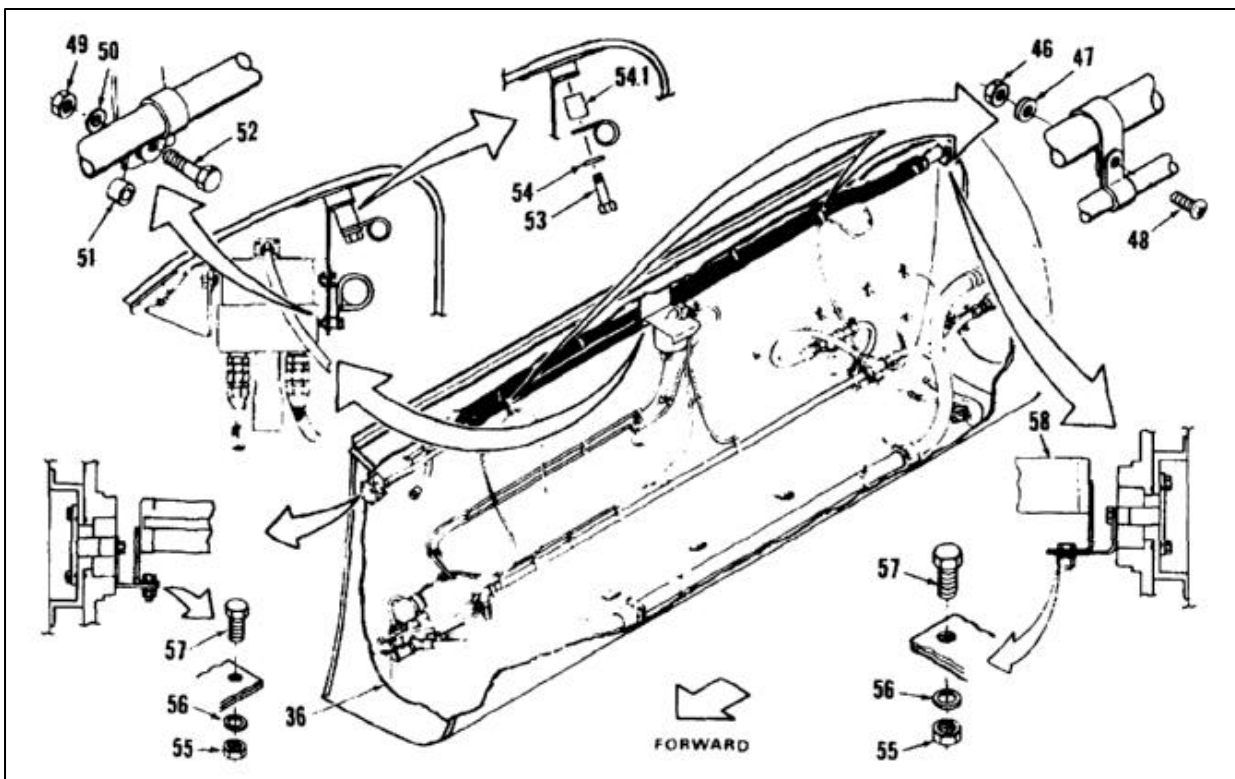
**FOLLOW-ON MAINTENANCE:**

None

END OF TASK

INITIAL SETUP

General Safety Instructions:

Applicable Configurations:

All

Tools:

Aircraft Mechanic's Tool Kit, NSN 5180-00-323-4692

Materials:

- Cloths (E135)
- Dry Cleaning Solvent (E162)
- Gloves (E186)

Personnel Required:

- Medium Helicopter Repairer
- Inspector

References:

TM 55-1520-240-23P

WARNING

All regulations and instructions for handling fuel shall be strictly observed.

CAUTION

Do not puncture or scratch lining of fuel cell. If lining is broken, fuel penetrates and activates self sealing layers. Activated layers swell and trap fuel. Activated green spongy material also contaminates fuel system. This makes it necessary to replace fuel cell and flush fuel system.

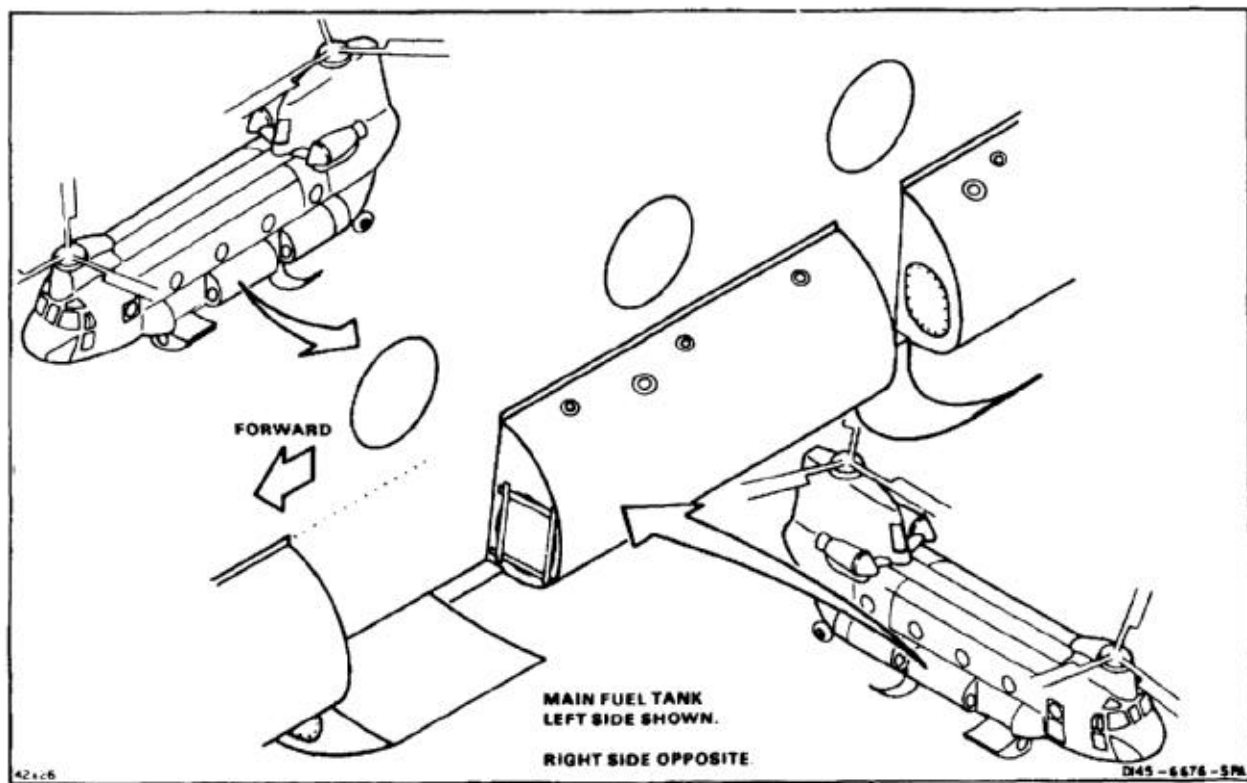

WARNING

Dry cleaning solvent (E162) is flammable and toxic. It can irritate skin and cause burns. Use only in well-ventilated area, away from heat and open flame. In case of contact, immediately flush skin or eyes with water for at least **15 minutes**. Get medical attention for eyes.

NOTE

Procedure is same to install No. 1 and No. 2 main fuel tank vent assembly. Installation of No. 1 (left) main fuel tank vent assembly is shown here.

1. Remove barrier material and tape from forward access hole (1) and aft access hole (2). Remove tape residue from face of tank. Use dry cleaning solvent (E162) and cloths (E135). Wear goggles to protect eyes. Wear gloves (E186).
2. Remove plugs from vent assembly (3) guide vent assembly into fuel cell (4) through forward access hole (1). Make sure air vent tube (5) is at forward end of cell.
3. Deleted.
4. Position vent assembly (3) between brackets (8). Adjust brackets as needed.
5. Install four screws (9), washers (10), and nuts (11).
6. Deleted.
7. Install washer (12), screw (13), and spacer (14) on fuel cell (4).
8. Install screw (15), spacer tube (16), washer (17), nut (18), and pipe clamp (19) on bracket (20).
9. Install two screws (21), washers (22), and nuts (23), through electrical cable clamp (24) and tube clamp (25).

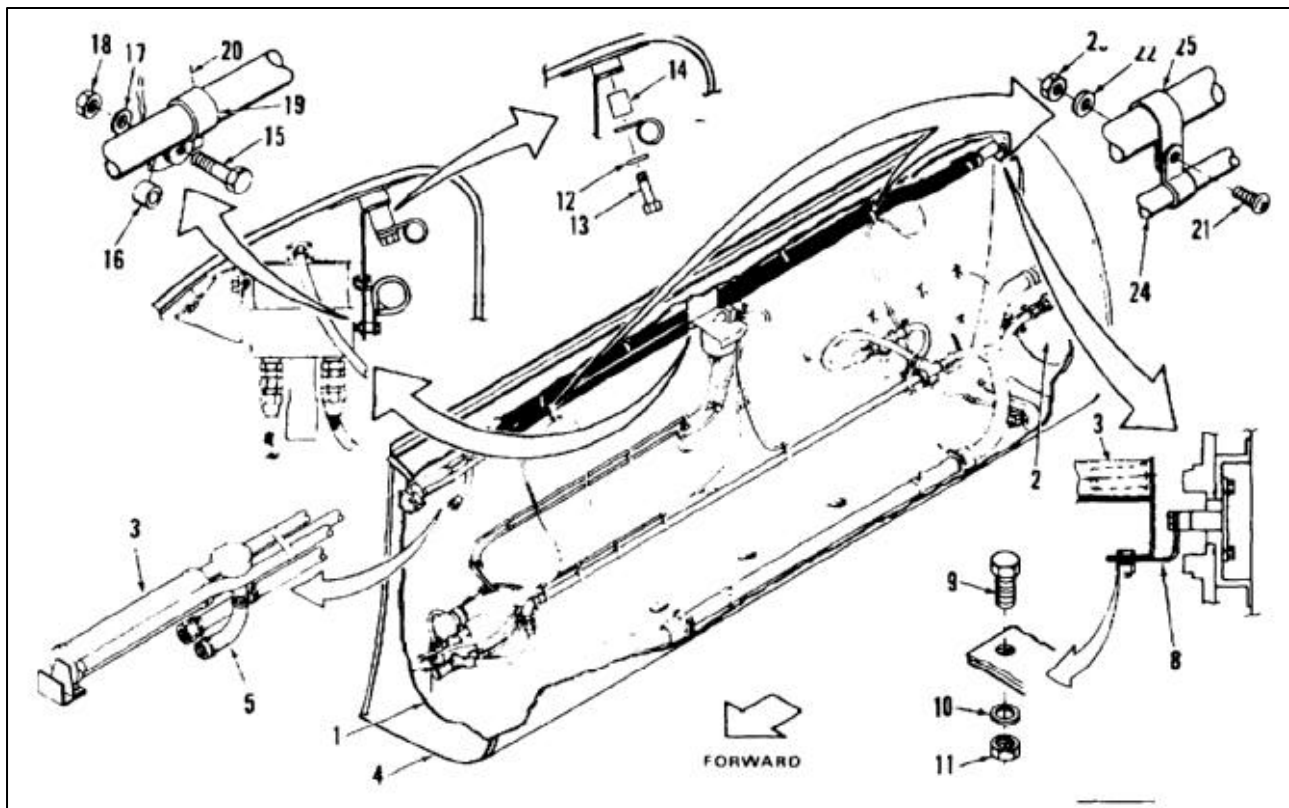

10. Remove plugs and tags from hose (26). Position hose in fuel cell (4). Connect hose connector (27).
11. Remove plugs and tags from tube (28). Position tube and ring (29). Connect hose connector (30).
12. Remove plugs and tags from hose (31). Position ring (29). Connect hose connectors (32 and 33).
13. Position two clamps (34). Install two washers (35) and screws (36).
14. Remove tags and plugs from hose and tube assembly (37) and position assembly in fuel cell (4) through forward access hole (1). Make sure flexible hose with **90°** connector is at aft end of fuel cell.
15. Connect hose connector (38).
16. Install screw (39), washer (40), and nut (41) to connect clamp (42) on hose (43) to clamp (44) on tube (28).

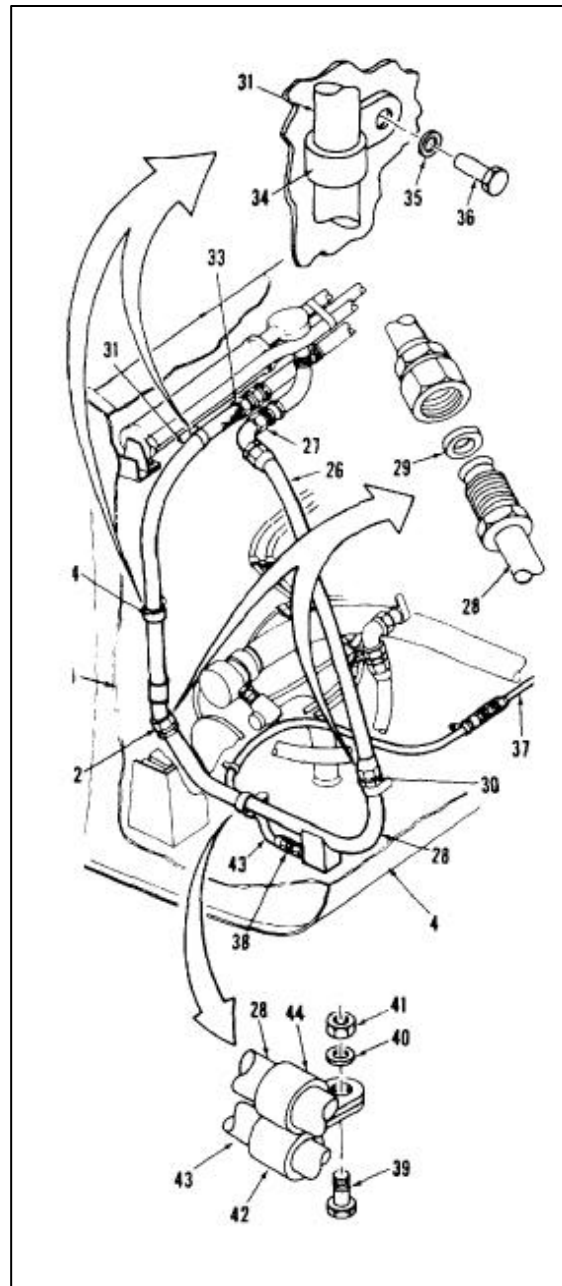

- | | |
|--|--|
| <p>17. Position clamp (45). Install bolt (46), washer (47), and nut (48).</p> <p>18. Position clamp (49). Install bolt (50) and washer (51).</p> <p>19. Install bolt (52), washer (53), and nut (54) to connect clamp (55) on hose (56) to clamp (57) on tee (58).</p> | <p>20. Position pipe assembly (59), clamp (60) and spacer (61). Install washer (62) and screw (63).</p> <p>21. Remove tags from four spacers (64) and position as indicated.</p> <p>22. Position four clamps (65). Install four washers (66) and screws (67).</p> <p>23. Position two hose clamps (68) and spacer (69). Install washer (70) and screw (71).</p> <p>24. Check that no high or low points occur in pipe assembly (59).</p> |
|--|--|

NOTE

Pipe assembly must be positioned so that no high or low spots in the assembly can trap fluids. Clamps and spacers must be positioned to remove slack in hose and ensure a level tube.

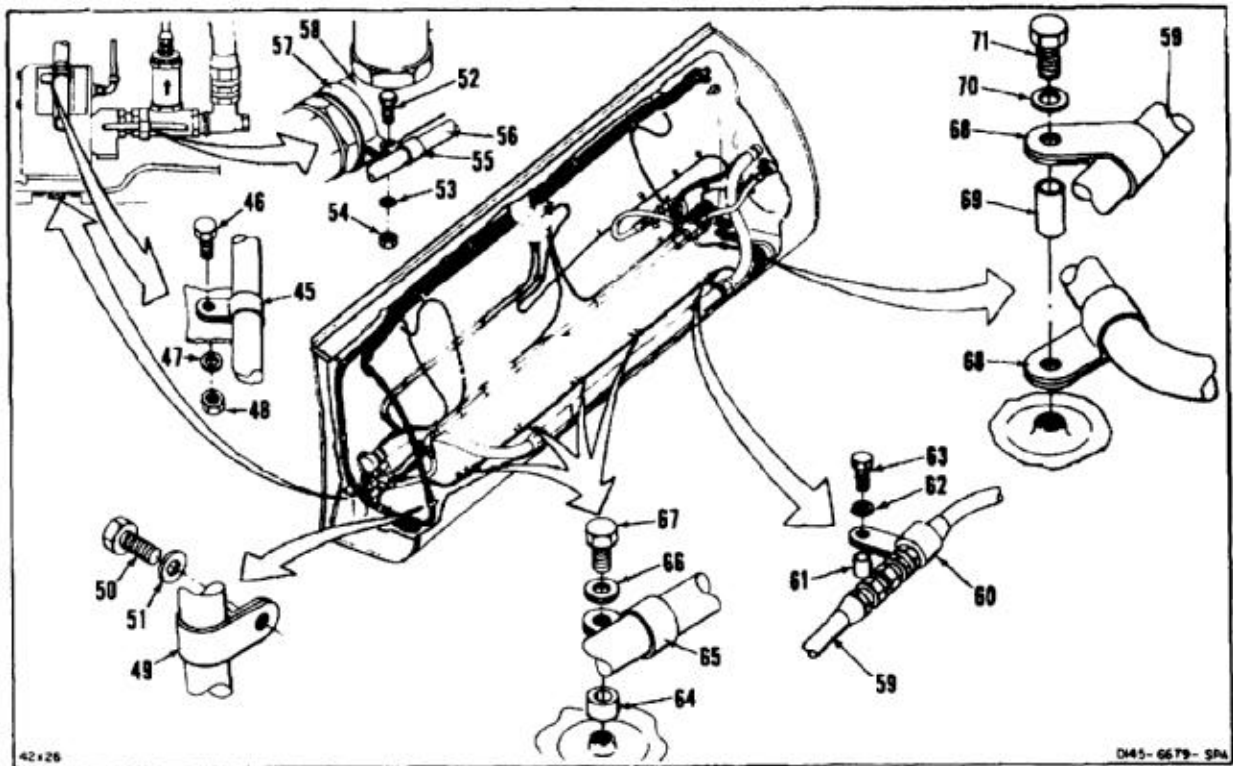

25. Remove tags and plugs from hose (72) and tube (73). Install tube if removed. Position hose in fuel cell (4).
26. Connect hose connector (74).
27. Position tube clamp (75) and tube clamp (76). Install screw (77), washer (78), and nut (79).
28. Install two screws (80) and washers (81) to connect tube clamp (82) to tank cell (4).
29. Remove tags and plugs from hose (83). Position hose in cell (4). Remove cap from drain valve (84). Connect 90° connector (85) to valve.
30. Remove tag and plug from hose connector (86) and caps from tee (87). Connect hose to tee.
31. Connect hose (72) to tee (87).
32. Position hose clamp (88) and electrical wire clamp (89). Install screw (90), washer (91), and nut (92).

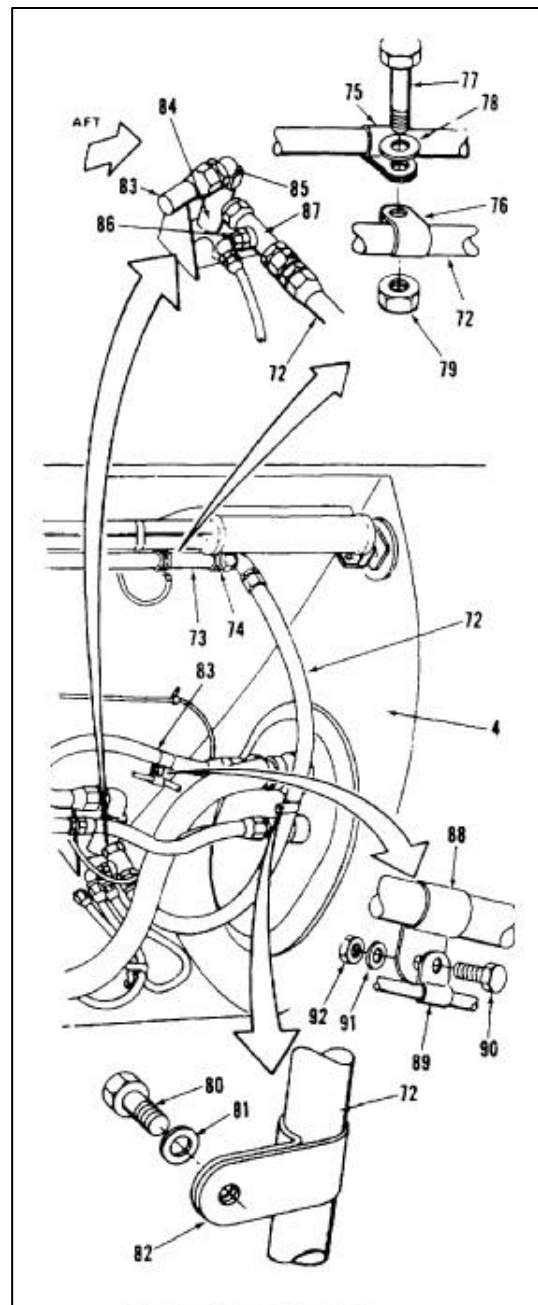
INSPECT

FOLLOW-ON MAINTENANCE:

Install main fuel tank transmitters (Task 8-82).
 Install main fuel tank aft access door (Task 10-54).
 Pressure test vent system (Task 10-117).
 Install main fuel tank forward access door (Task 10-52).
 Test fuel tank after installation (Task 10-22).

Perform vent system flow test (Task 10-118).
 Install forward fuel tank (Task 10-26).
 Perform test of pressure refueling system (Task 10-119) and fuel feed system (Task 10-120).
 Refuel helicopter (Task 1-51).
 Bleed fuel system (Task 10-121).

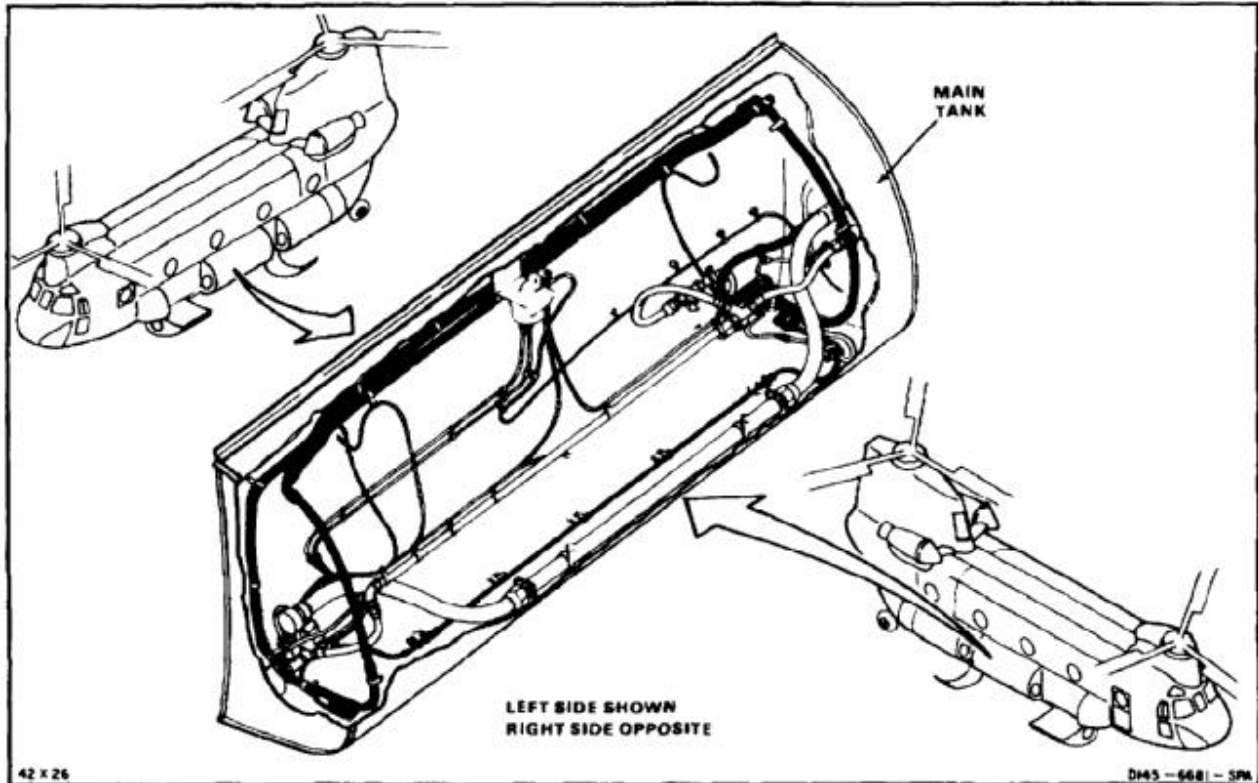

END OF TASK

INITIAL SETUP

Applicable Configurations:

All

Tools:

Aircraft Mechanic's Tool Kit, NSN 5180-00-323-4692

Materials:

Barrier Material (E80)
Tape (E388)

Personnel Required:

Medium Helicopter Repairer

Equipment Condition:

Battery Disconnected (Task 1-39)
Electrical Power Off
Helicopter Grounded (Task 1-29)
Main Fuel Tank Defueled (Task 10-34 or 10-35)
Aft Intertank Pod Panel Lowered (Task 2-185)
Main Fuel Tank Aft Access Door Removed (Task 10-53)

General Safety Instructions:

WARNING

All regulations and instructions for handling fuels shall be strictly observed.

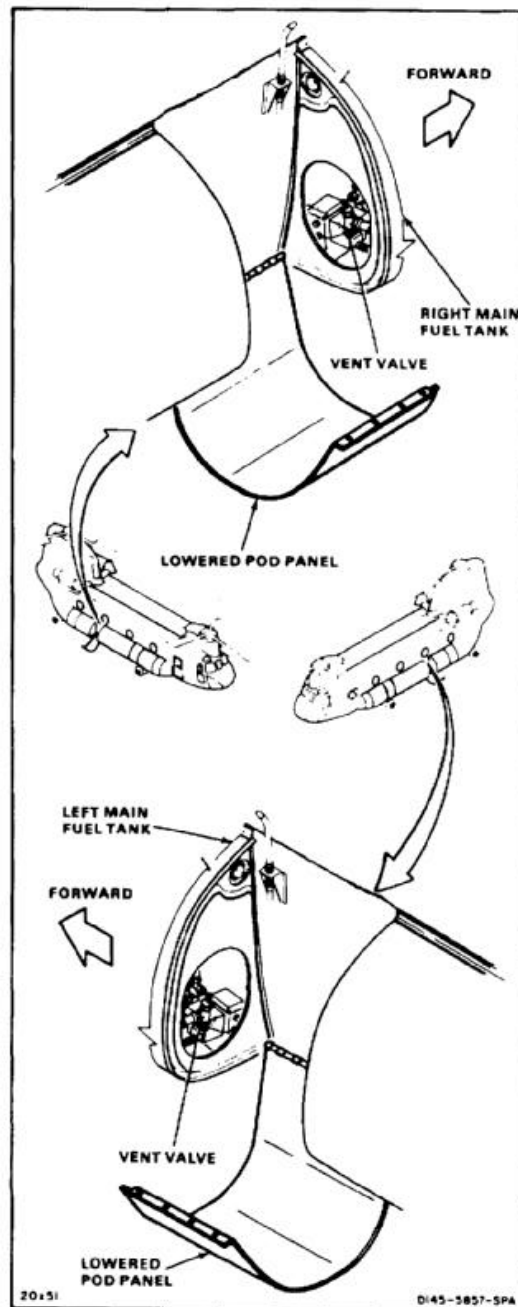

CAUTION

Do not puncture or scratch lining of fuel tank. If lining is broken, fuel penetrates and activates self-sealing layers. Activated layers swell and trap fuel. Activated green spongy material also contaminates fuel system. This makes it necessary to replace fuel tank and flush fuel system.

NOTE

Procedure is same to remove vent valve in No. 1 or No. 2 main fuel tank. Removal of No. 2 (right) vent valve is shown here.

1. Disconnect hose (1) from vent valve (2). Plug and remove hose from tank (3).
2. Disconnect hose (4) from valve (2).
3. Remove four bolts (5) and washers (6).
4. Remove valve (2) and gasket (7) from adapter plate (8) and bracket (9).
5. Cover access hole (10) in tank (3). Use barrier material (E80) and tape (E388).

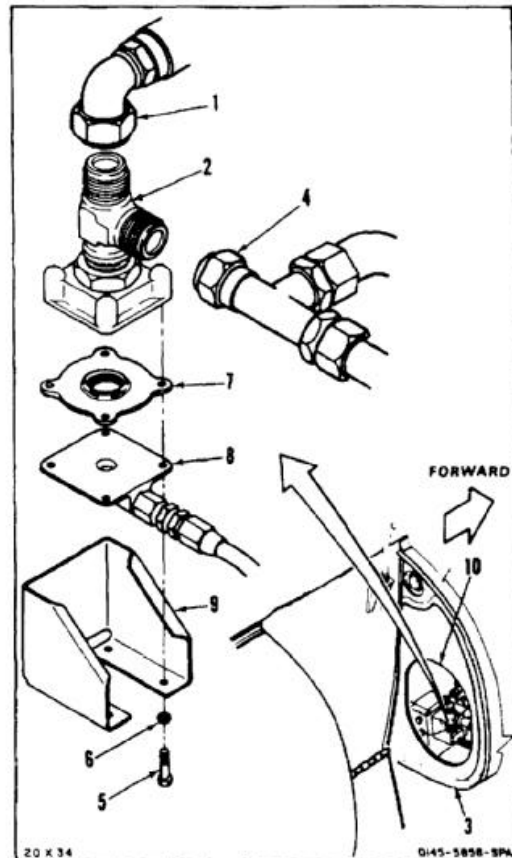
**FOLLOW-ON MAINTENANCE:**

None

END OF TASK

INITIAL SETUP

Applicable Configurations:

All

Tools:

Aircraft Mechanic's Tool Kit, NSN 5180-00-323-4692

Materials:

None

Personnel Required:

Medium Helicopter Repairer

Equipment Condition:

Off Helicopter Task

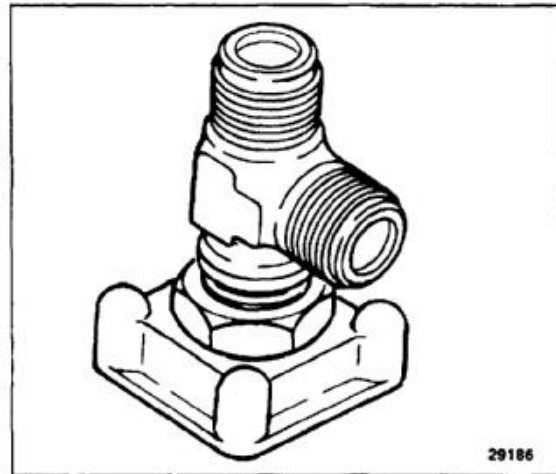

1. Loosen nut (1) and remove base (2) from body (3).
2. Remove concave washer (4), valve retainer (5), floats (6), balls (7), tubes (8), seats (9), packings (10), and packing (11).

FOLLOW-ON MAINTENANCE:

None

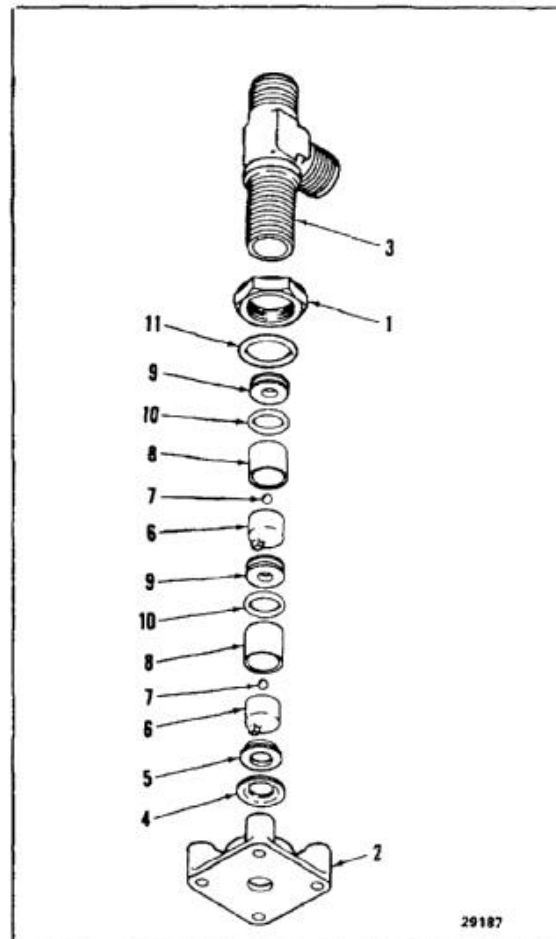

END OF TASK

10-45.2 ASSEMBLE FUEL VENT VALVE

10-45.2

INITIAL SETUP**Applicable Configurations:**

All

Tools:

Aircraft Mechanic's Tool Kit, NSN 51 80-00-323-4692

Materials:

None

Personnel Required:

Medium Helicopter Repairer

Equipment Condition:

Off Helicopter Task

1. Install nut (1) and packing (11) onto body (3).
2. Install packings (10) on seats (9).
3. Install packing (10) and seat (9) into body (3).
4. Install tube (8), ball (7), and float (6) into body (3).
5. Install packing (10) and seat (9) into body (3).
6. Install tube (8), ball (7), and float (6) into body (3).
7. Install retainer (5) and concave washer (4) into body (3).
8. Install base (2) onto body (3).

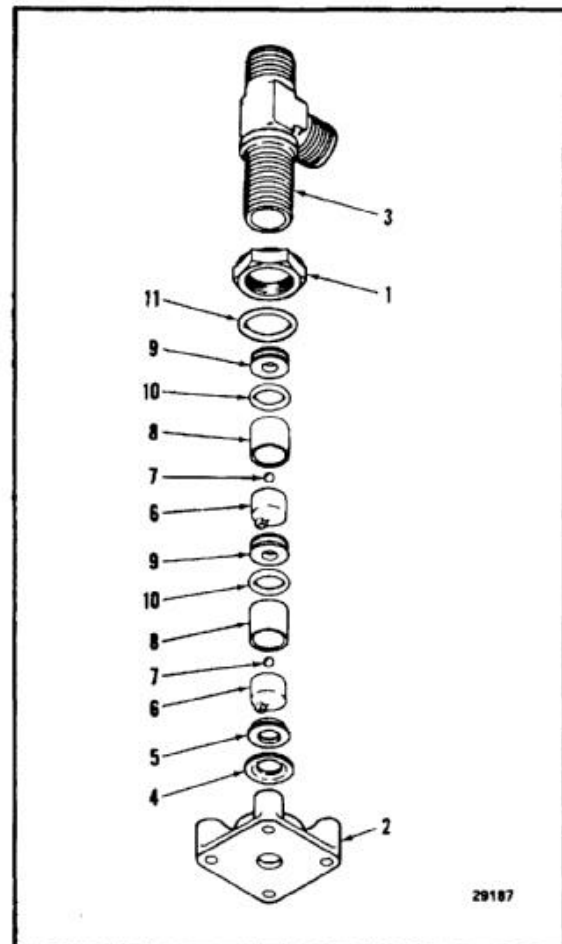

9. Tighten base (2) on body (3).
10. Orient body (3) so that horizontal fitting is at 90° to one of the base (2) sides and that the distance from the center of the horizontal fitting and the bottom of the base is **2.75 to 2.88 inches**.
11. Tighten nut (4).

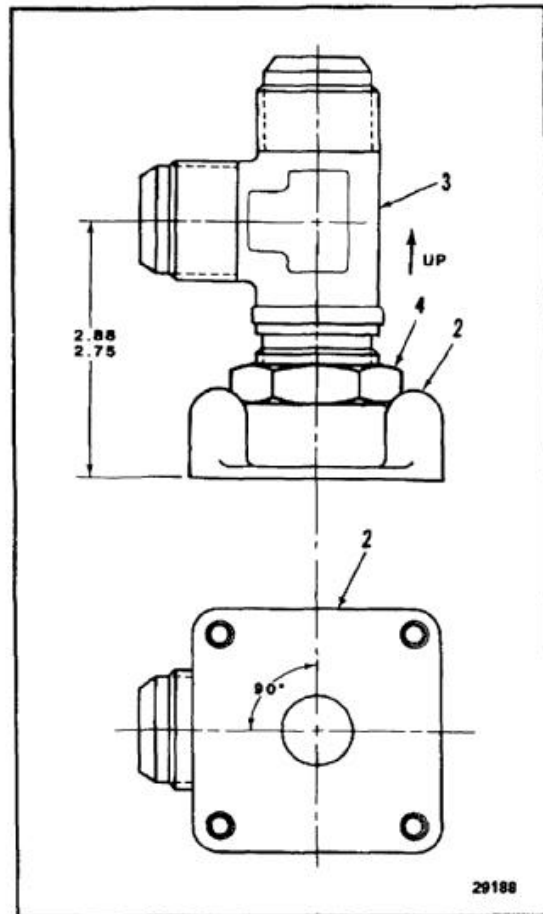
**FOLLOW-ON MAINTENANCE:**

None

END OF TASK

10-230

INITIAL SETUP

Applicable Configurations:

All

Tools:

Aircraft Mechanic's Tool Kit, NSN 5180-00-323-4692

Materials:

Dry Cleaning Solvent (E162)
Cloths (E135)
Gloves (E186)

Parts:

Gasket

Personnel Required:

Medium Helicopter Repairer
Inspector

References:

TM 55-1520-240-23P

General Safety Instructions:**WARNING**

All regulations and instructions for handling fuels shall be strictly observed.

NOTE

Procedure is same to install vent valve in No. 1 or No. 2 main fuel tank. Installation of No. 2 (right) vent valve is shown here.

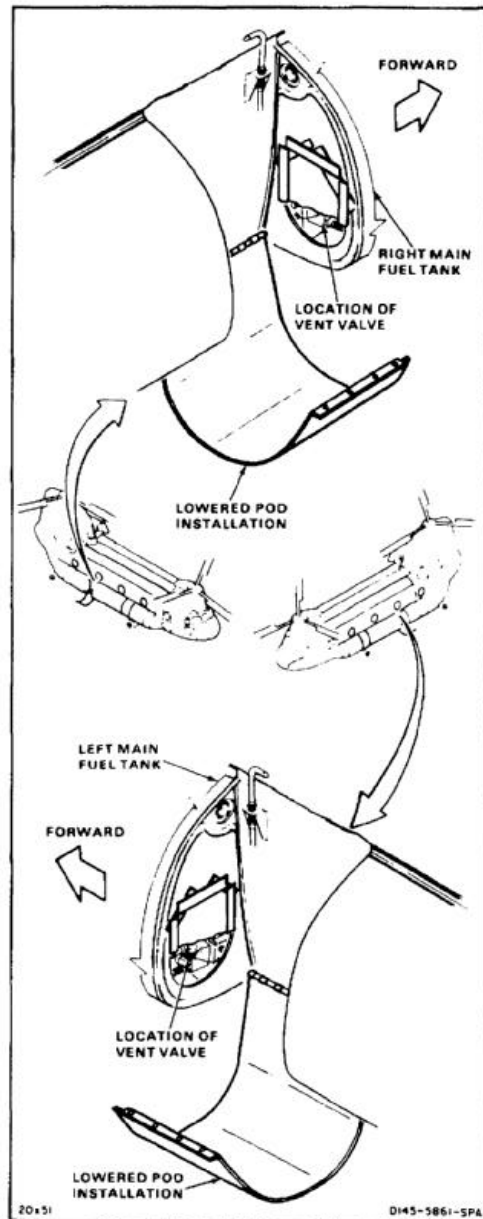

WARNING

Dry cleaning solvent (E162) is flammable and toxic. It can irritate skin and cause burns. Use only in well-ventilated area, away from heat and open flame. In case of contact, immediately flush skin or eyes with water for at least **15 minutes**. Get medical attention for eyes.

1. Remove barrier material and tape from hole (1) in tank (2). Remove tape residue from tank. Use dry cleaning solvent (E162) and cloths (E15). Wear goggles to protect eyes. Wear gloves (E186).

CAUTION

Do not puncture or scratch lining of fuel tank. If lining is broken, fuel penetrates and activates self-sealing layers. Activated layers swell and trap fuel. Activated green spongy material also contaminates fuel system. This makes it necessary to replace fuel tank and flush fuel system.

2. Position adapter plate (3), gasket (4), and valve (5), with valve port (6) outboard, on bracket (7).
3. Install four washers (8) and bolts (9).
4. Connect tube (10) to valve (5).
5. Remove plug from hose (11). Connect hose to valve (5).

INSPECT**FOLLOW-ON MAINTENANCE:**

Perform vent system pressure test (Task 10-117).
 Install access door (Task 10-54).
 Test main fuel tank (Task 10-22).
 Perform vent system flow test (Task 10-118).
 Perform test of pressure refueling system (Task 10-119) and fuel feed system (Task 10-120).
 Refuel helicopter (Task 1-51).
 Bleed fuel system (Task 10-121).
 Perform operational check of affected fuel system (TM 55-1520-240-T).
 Inspect for leaks (Task 10-4).
 Close and latch aft intertank pod panel (Task 2-188).

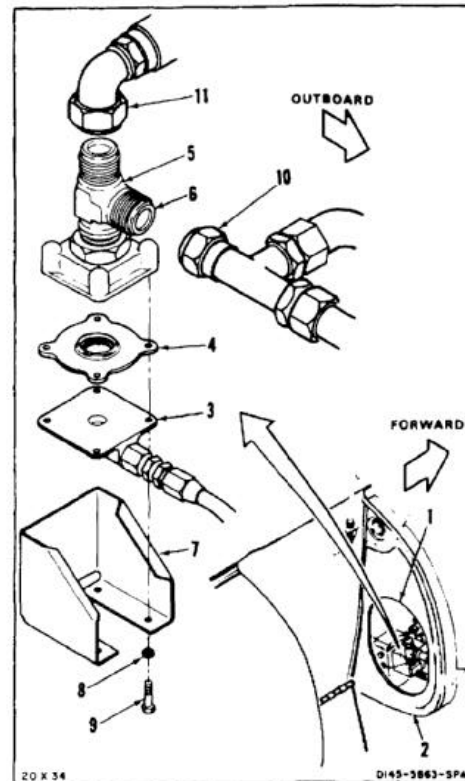

END OF TASK

10-232

INITIAL SETUP

Applicable Configurations:

All

Tools:

Aircraft Mechanic's Tool Kit, NSN 5180-00-323-4692
Grounded Container, 2 Quart or Equivalent

Materials:

Cloths (E135)
Barrier Material (E80)
Tape (E388)

Personnel Required:

Medium Helicopter Repairer

Equipment Condition:

Battery Disconnected (Task 1-39)
Electrical Power Off
Helicopter Grounded (Task 1-29)
Forward Landing Gear Access Panel Opened (Task 2-2)
All Tanks on Affected Side of Helicopter Defueled and Both Crossover Valves Closed (Task 10-34 or 10-35)
Affected Main Fuel Tank Purged (Task 10-2)
Main Fuel Tank Fuel Level Shutoff Valve Removed (No. 1 System — Task 10-55 (Without **82**), 10-55.1 (With **82**), No. 2 System — Task 10-57)

General Safety Instructions:**WARNING**

All regulations and instructions for handling fuels shall be strictly observed.

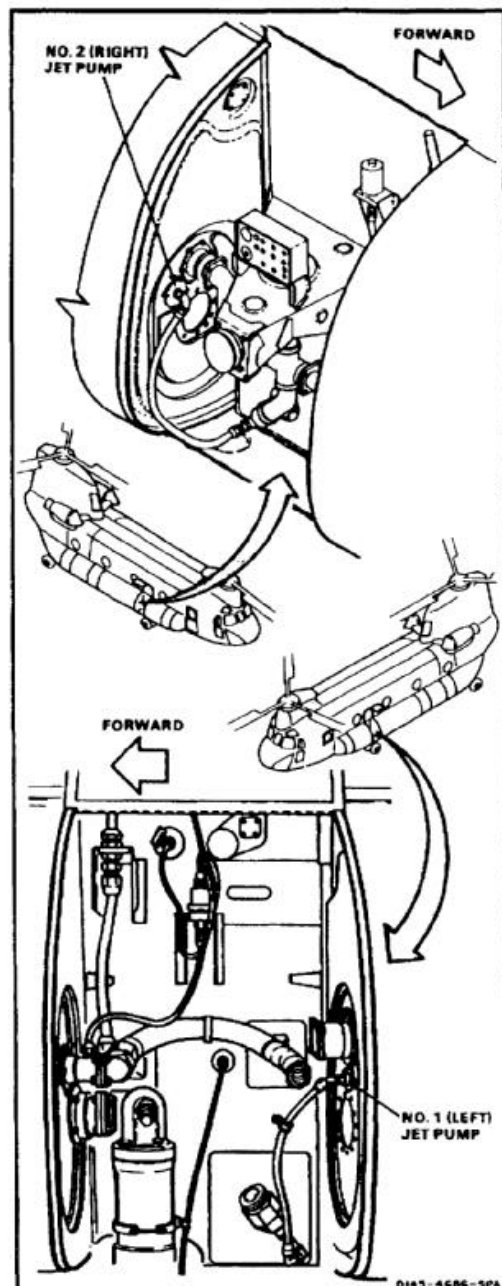

NOTE

Procedure is same to remove No. 1 or No. 2 jet pump. Removal of No. 1 (left) pump is shown here.

1. Disconnect hose (1) from jet pump (2). Use grounded container to catch spilled fuel.
2. Clean up spilled fuel. Use cloths (E135).

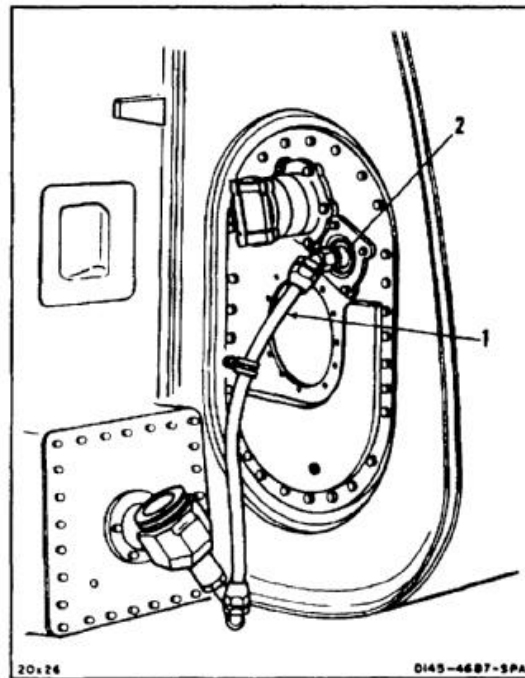

CAUTION

Do not puncture or scratch lining of fuel tank. If lining is broken, fuel penetrates and activates self-sealing layers. Activated layers swell and trap fuel. Activated green spongy material also contaminates fuel system. This makes it necessary to replace fuel tank and flush fuel system.

3. Reach through hole in tank (3). Disconnect hose (4) from jet pump (2). Carefully lower hose inside tank.
4. Remove four bolts (5) and washers (6).
5. Remove jet pump (2) from tank (3).
6. Cover two holes in tank (3). Use barrier material (E80) and tape (E388).

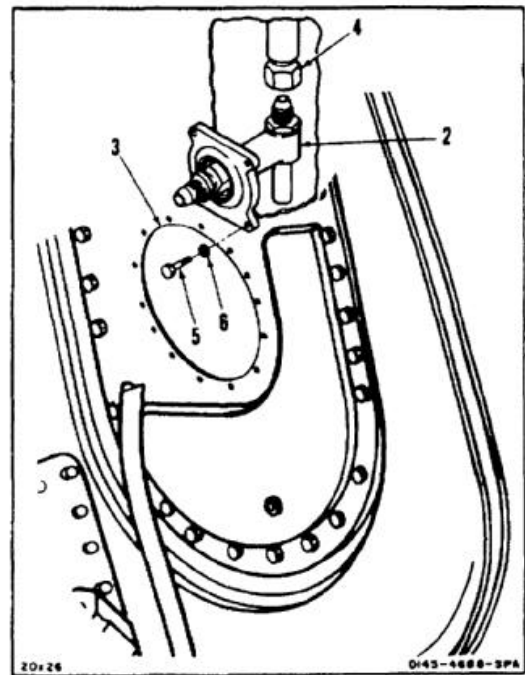

10-47 REMOVE MAIN FUEL TANK JET PUMP (Continued)**10-47**

7. Remove packing (7) from flange of jet pump (2).

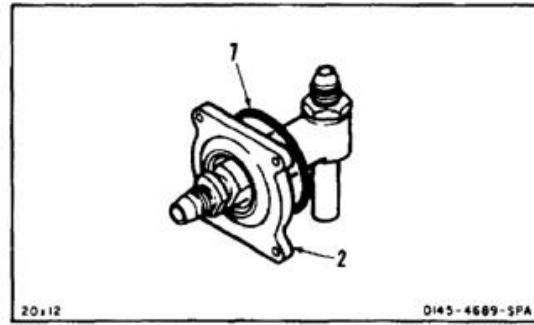
***FOLLOW-ON MAINTENANCE:***

None

END OF TASK

INITIAL SETUP

Applicable Configurations:

All

Tools:

Aircraft Mechanic's Tool Kit, NSN 5180-00-323-4692

Materials:

- Cloths (E135)
- Dry Cleaning Solvent (E162)
- Gloves (E186)

Parts:

Packing

Personnel Required:

Medium Helicopter Repairer
Inspector

References:

TM 55-1520-240-23P

General Safety Instructions:

WARNING

All regulations and instructions for handling fuels shall be strictly observed.

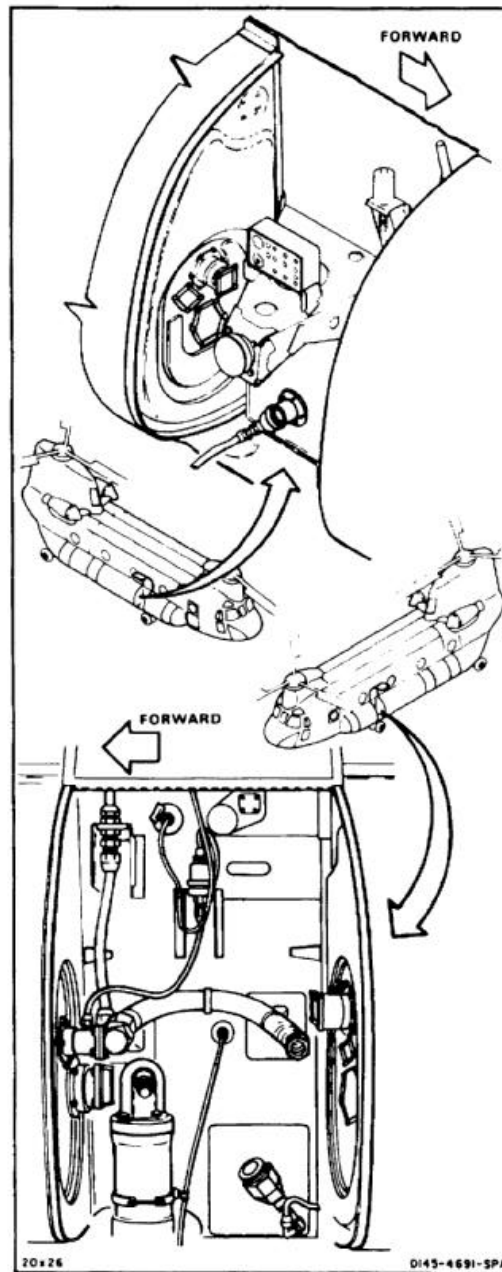

NOTE

Procedure is same to install No. 1 or No. 2 jet pump. Installation of No. 1 (left) pump is shown here.

1. Install packing (1) on jet pump (2).

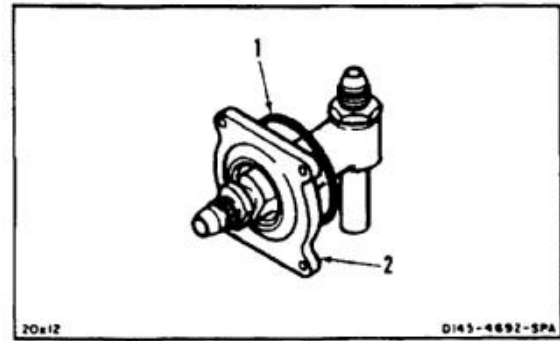
**WARNING**

Dry cleaning solvent (E162) is flammable and toxic. It can irritate skin and cause burns. Use only in well-ventilated area, away from heat and open flame. In case of contact, immediately flush skin or eyes with water for at least **15 minutes**. Get medical attention for eyes.

2. Remove barrier material and tape from two holes in tank (3). Clean tape residue from tank. Use dry cleaning solvent (E162) and cloths (E135). Use goggles for eyes. Wear gloves (E186).
3. Maneuver jet pump (2) into position in tank (3).
4. Install four bolts (4) and washers (5).

CAUTION

Do not puncture or scratch lining of fuel tank. If lining is broken, fuel penetrates and activates self-sealing layers. Activated layers swell and trap fuel. Activated green spongy material also contaminates fuel system. This makes it necessary to replace fuel tank and flush fuel system.

5. Reach through hole (6) in tank (3) and connect hose (7) to jet pump (2).

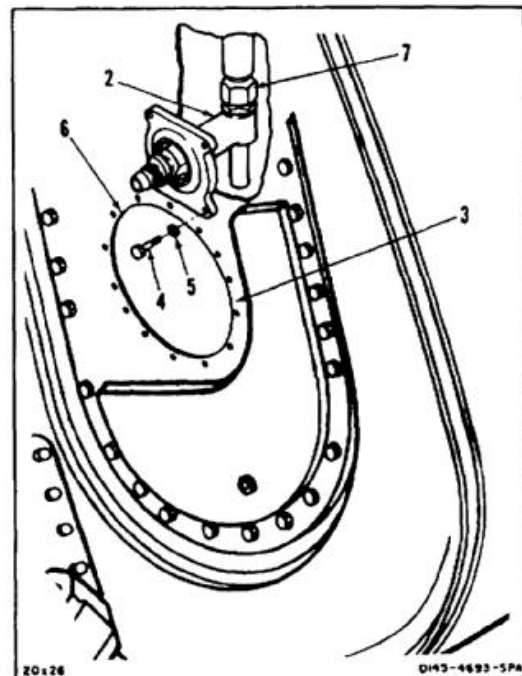

6. Connect hose (8) to jet pump (2).

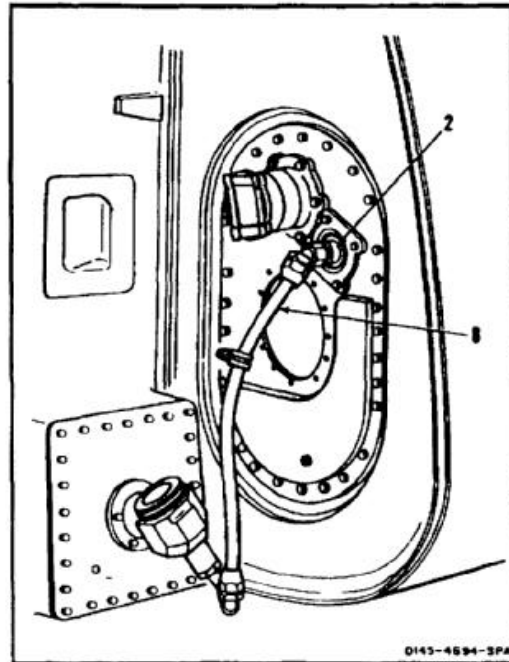

INSPECT

FOLLOW-ON MAINTENANCE:

- Perform vent system pressure test (Task 10-117).
- Install main tank fuel level shutoff valve (for No. 1 system (left) Task 10-56 (Without **82**), Task 10-56.1 (With **82**), for No. 2 system (right) Task 10-58).
- Perform vent system flow test (Task 10-118).
- Perform test of pressure refueling system (Task 10-119) and fuel feed system (Task 10-120).
- Refuel affected side of helicopter (Task 1-51).
- Bleed fuel system (Task 10-121).
- Check for leaks (Task 10-4).
- Perform functional check of fuel system (TM 55-1520-240-T).
- Close forward landing gear access panel (Task 2-2).

END OF TASK

10-48.1 REMOVE FUEL TANK BREAKAWAY FITTINGS

10-48.1

INITIAL SETUP

Applicable Configurations:

All

Tools:

Aircraft Mechanic's Tool Kit, NSN 51 80-00-323-4692
 Grounded Container, 2 Quart

Materials:

Cloths (E135)

Personnel Required:

Medium Helicopter Repairer

Equipment Condition:

Battery Disconnected (Task 1-39)
 Electrical Power Off
 Helicopter Grounded (Task 1-29)
 Forward Landing Gear Door Opened (Task 2-2) or Aft
 Intertank Pod Panel Lowered (Task 2-185)
 Affected Tank Defueled and Crossover Valves Closed
 (Task 10-34 or 10-35)

General Safety Instructions:

WARNING

All regulations and instructions for handling fuels shall be strictly observed.

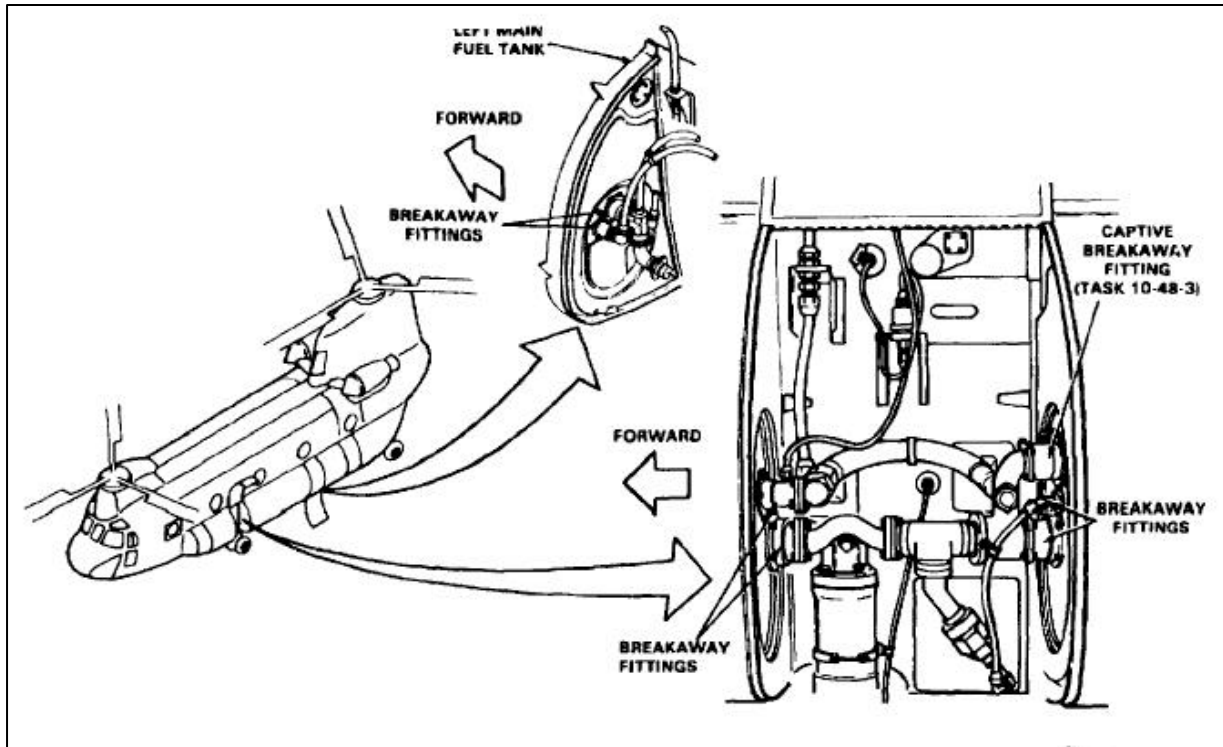

CAUTION

Parts connected to breakaway fittings must be removed without applying force to fitting. Otherwise fitting may be broken.

NOTE

Procedure is similar to remove breakaway fittings from any fuel tank except captive breakaway fitting (1) at forward and aft ends of main fuel tank (Task 10-48.3). Forward No. 1 (left) intertank area shown here contains typical breakaway fitting installations.

1. Loosen flange bolts (2). Use wrench on flats (3), to prevent application of force to breakaway fittings. Disconnect other end of tube (4), and remove applicable seals and packings. Catch spilled fuel. Use grounded container.
2. Disconnect hose (10.1).
3. Remove hose coupling (6), eight bolts (7), washer (8), and nuts (9). Remove hose (10), tube (11), and manifold (5) as an assembly.
4. Remove six screws (12) and washers (13). Remove breakaway fitting (14) and packing (15). Wipe up spilled fuel. Use cloths (E135).

FOLLOW-ON MAINTENANCE:

None

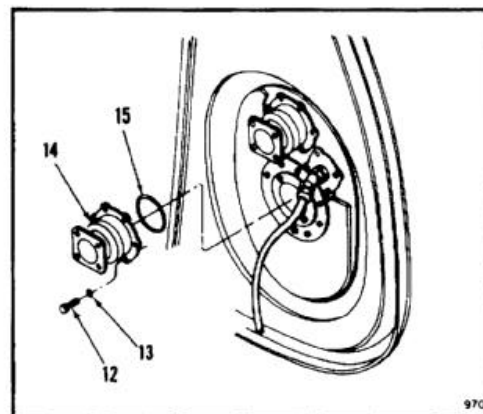
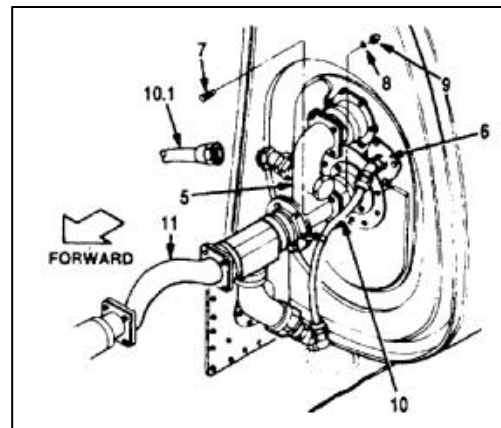
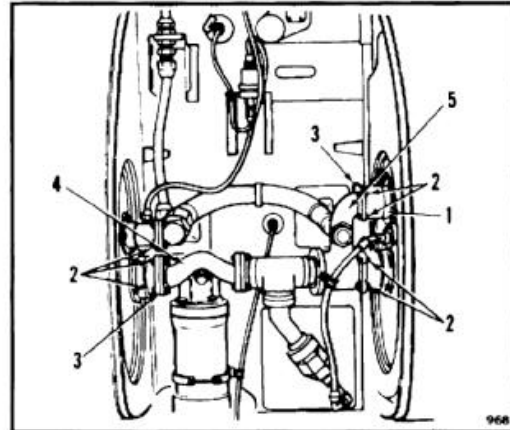

END OF TASK

10-240

10-48.2 INSTALL FUEL TANK BREAKAWAY FITTINGS

10-48.2

INITIAL SETUP

Applicable Configurations:

All

Tools:

Aircraft Mechanic's Tool Kit, NSN 51 80-00-323-4692

Materials:

None

Personnel Required:

Medium Helicopter Repairer
Inspector

General Safety Instructions:

WARNING

All regulations and instructions for handling fuels shall be strictly observed.

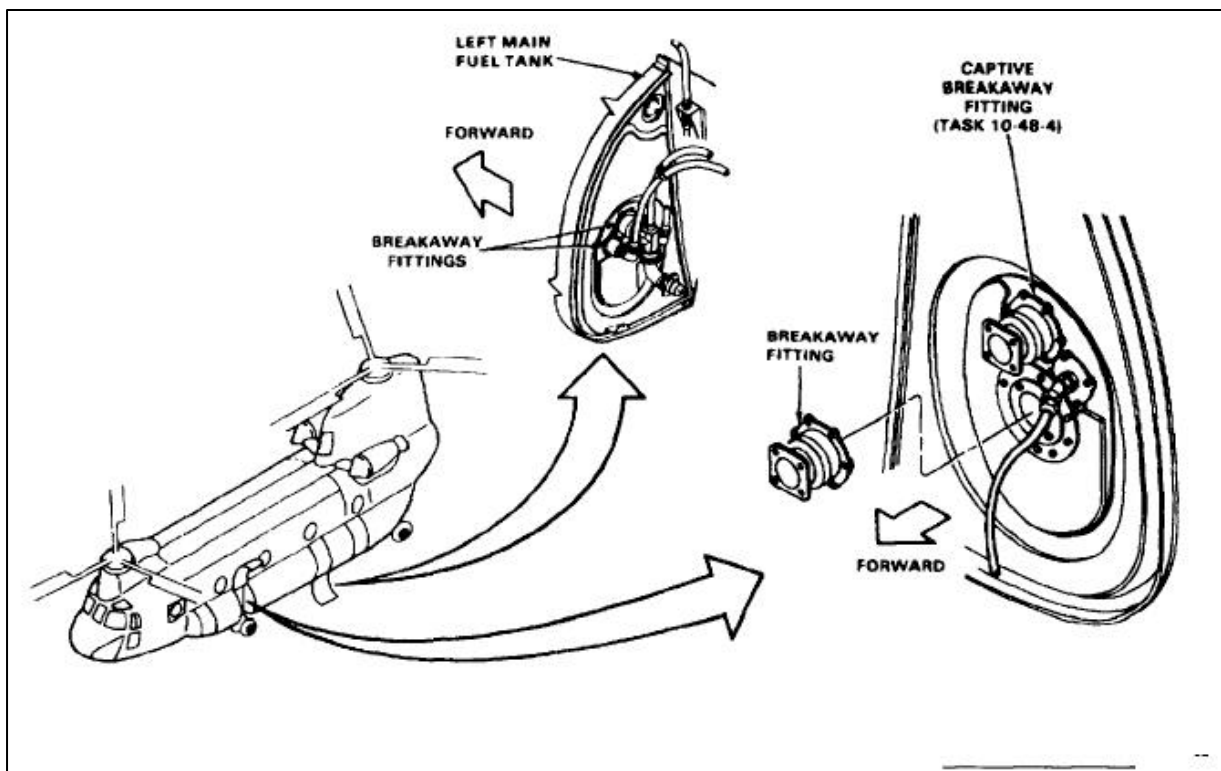

CAUTION

Parts connected to breakaway fittings must be installed without applying force to fitting. Otherwise fitting may break.

NOTE

Procedure is similar to install breakaway fittings in any fuel tank except captive breakaway fitting (1) at forward and aft ends of main fuel tank (Task 10-48.4). Forward No. 1 (left) intertank area shown here contains typical breakaway fitting installations.

1. Position packing (2) and breakaway fitting (3) on fuel tank (4). Install six screws (5) and washers (6).
2. Position manifold (7), hose (8), tube (9) and applicable seals and packings on breakaway fittings (3). Install eight bolts (10), washers (11), and nuts (12) loosely. If connecting hose coupling (13) breakaway fitting, hold flats with wrench while tightening. Connect tube at other end.
3. Connect hose (14).
4. Tighten bolts (10) at breakaway fittings (3). Use wrench on flats to prevent application of force to breakaway fittings.

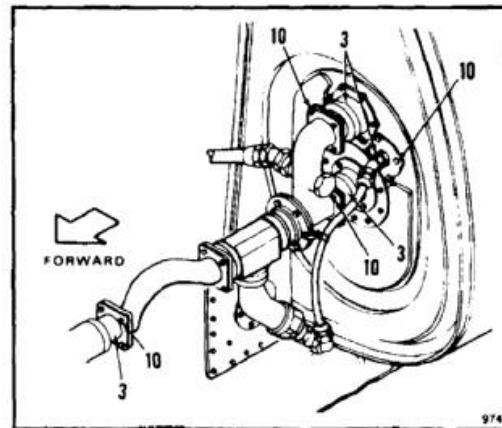
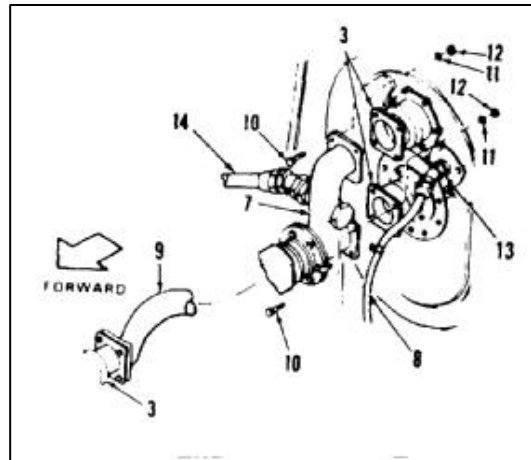
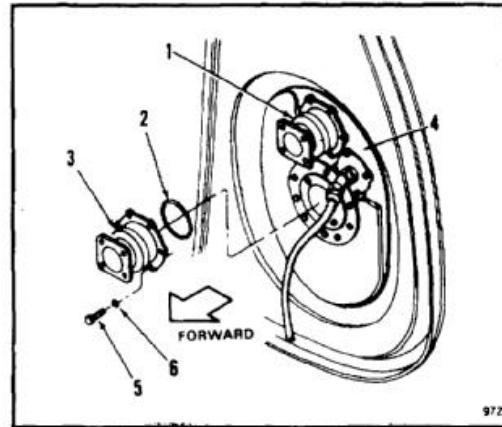

FOLLOW-ON MAINTENANCE:

- Perform vent system flow test (Task 10-118).
- Perform pressure refueling system test (Task 10-119).
- Test affected tank after installation (Task 10-22, 10-27, or 10-32).
- Refuel helicopter (Task 10-51).
- Check for leaks (Task 10-4).
- Bleed fuel system (Task 10-121).
- Perform operational check of fuel system (TM 55-1520-240-T).
- Close forward landing gear door or aft intertank pod panel (Task 2-2 or 2-188).

END OF TASK

10-48.3 REMOVE CAPTIVE BREAKAWAY FITTING

10-48.3

INITIAL SETUP**Applicable Configurations:**

All

Tools:

Aircraft Mechanic's Tool Kit, NSN 5180-00-323-4692
Grounded Container, 2 Quart or Equivalent

Materials:

None

Personnel Required:

Medium Helicopter Repairer

Equipment Condition:

Battery Disconnected (Task 1-39)
Electrical Power Off
Helicopter Grounded (Task 1-29)
Forward Landing Gear Door Opened (Task 2-2) or Aft
Intertank Pod Panel Lowered (Task 2-185)
Affected Tank Defueled and Crossover Valves Closed
(Task 10-34 or 10-35)
Main Fuel Tank Forward Access Door Removed
(Task 10-51) or Main Fuel Tank Aft Access Door
Removed (Task 10-54)

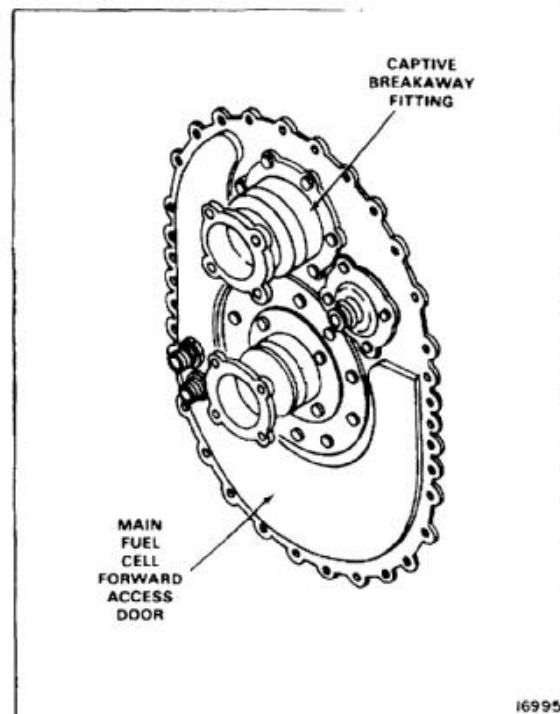
**NOTE**

Procedure is the same to remove captive breakaway fitting from any fuel tank access door. Main fuel tank forward access door is shown here.

1. Remove six screws (1) and washers (2).
2. Remove fitting (3) and packing (4) from access door (5).

FOLLOW-ON MAINTENANCE:

None

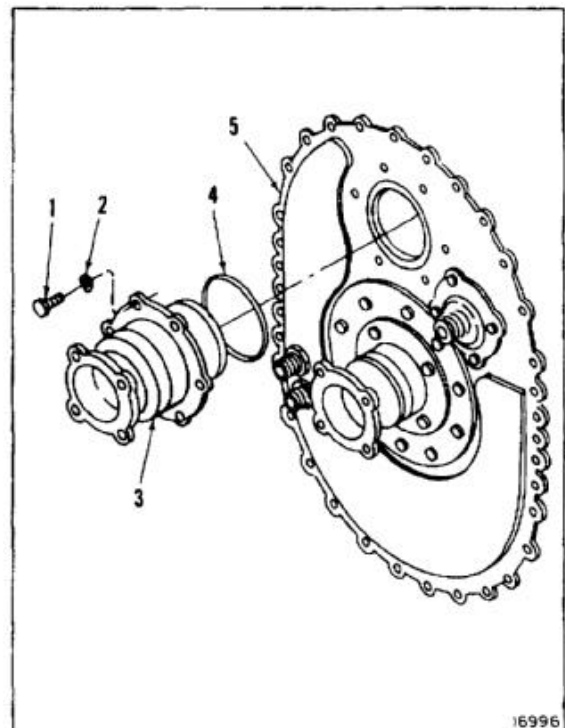

END OF TASK

INITIAL SETUP

Applicable Configurations:

All

Tools:

Aircraft Mechanic's Tool Kit, NSN 5180-00-323-4692

Materials:

None

Personnel Required:

Medium Helicopter Repairer

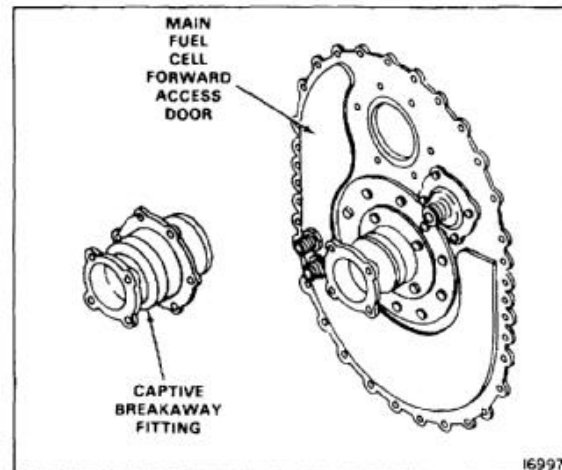
**NOTE**

Procedure is the same to install captive breakaway fitting from any fuel tank access door. Main fuel tank forward access door is shown here.

1. Position packing (1) and captive breakaway fitting (2) on access door (3).
2. Install six screws (4) and washers (5).

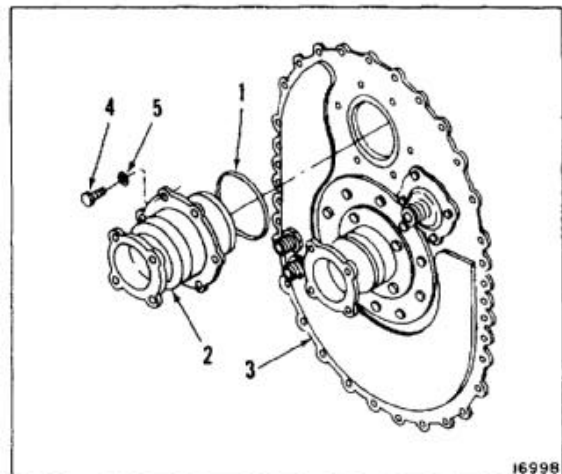
**FOLLOW-ON MAINTENANCE:**

Install fuel cell forward or aft access door (Task 10-52 or 10-54).

END OF TASK

10-244

INITIAL SETUP

Applicable Configurations:

All

Tools:

Aircraft Mechanic's Tool Kit, NSN 51 80-00-323-4692

Material:Barrier Material (E80)
Tape (E388)**Personnel Required:**

Medium Helicopter Repairer

Equipment Condition:Battery Disconnected (Task 1-39)
Electrical Power Off
Helicopter Grounded (Task 1-29)
Forward Landing Gear Access Panel Opened (Task 2-2)
Main Fuel Tank Forward Access Door Removed (Task 10-51)**General Safety Instructions:****WARNING**

All regulations and instructions for handling fuels shall be strictly observed.

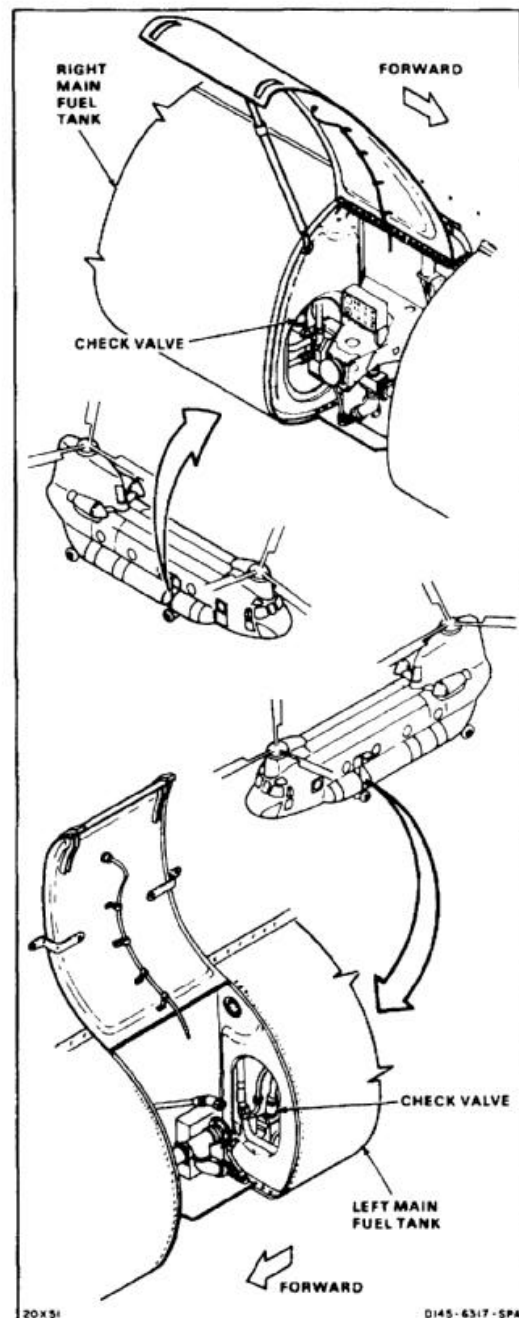

NOTE

Procedure is same to remove check valve from No. 1 or No. 2 main fuel tank removal of No. 1 (left) check valve is shown here.

1. Disconnect hose (1).
2. Remove check valve (2) and packing (3) from tee (4).
3. Cover access hole in tank (5) with barrier material (E80) and tape (E388).

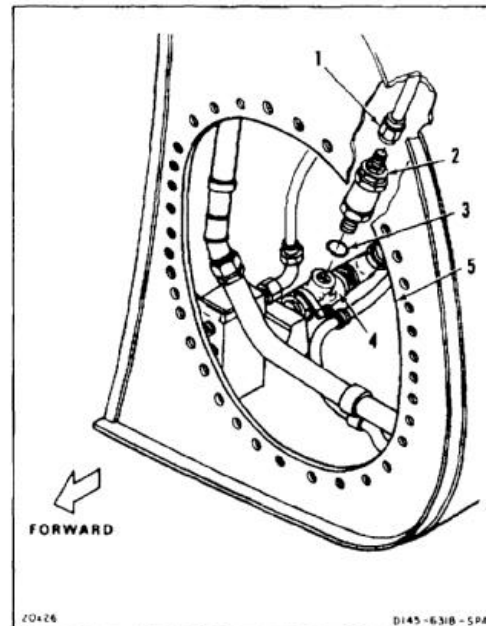
**FOLLOW-ON MAINTENANCE:**

None

END OF TASK

10-246

INITIAL SETUP

Applicable Configurations:

All

Tools:

Aircraft Mechanic's Tool Kit, NSN 5180-00-323-4692

Materials:

Dry Cleaning Solvent (E162)
 Cloths (E120)
 Gloves (E186)

Parts:

Packings

Personnel Required:

Medium Helicopter Repairer
 Inspector

References:

TM 55-1520-240-23P

General Safety Instructions:**WARNING**

All regulations and instructions
 for handling fuels shall be strictly
 observed.

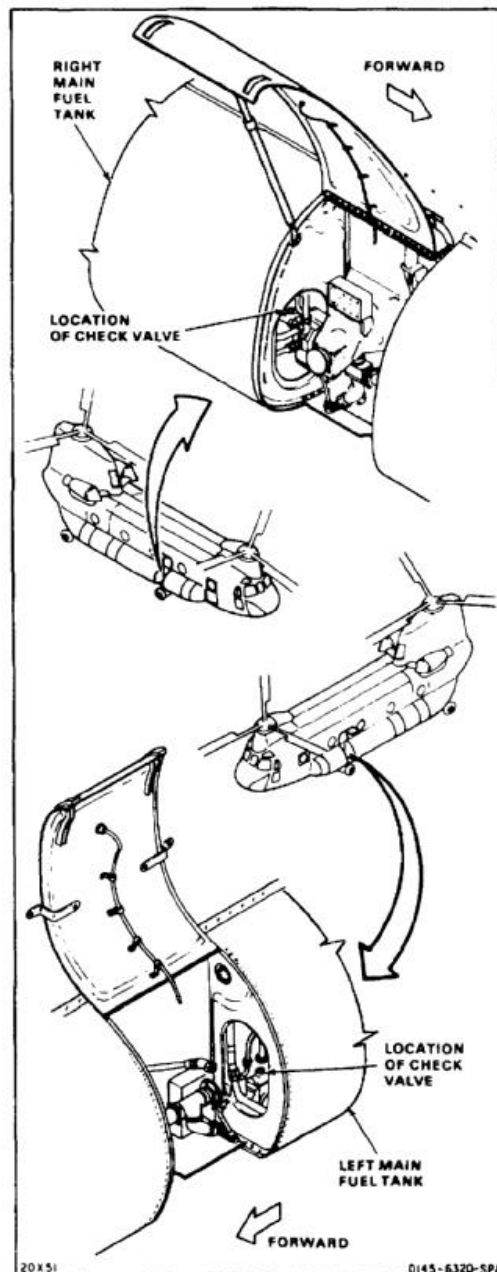

WARNING

Dry cleaning solvent (E162) is flammable and toxic. It can irritate skin and cause burns. Use only in well-ventilated area, away from heat and open flame. In case of contact, immediately flush skin or eyes with water for at least **15 minutes**. Get medical attention for eyes.

NOTE

Procedure is same to install motive flow check valve in No. 1 or No. 2 main fuel tank. Installation of No. 1 (left) check valve is shown here.

1. Remove barrier material and tape from access hole in tank (1). Clean tape residue from tank. Use dry cleaning solvent (E162) and clean cloths (E120). Wear goggles to protect eyes. Wear gloves (E186).

CAUTION

Do not puncture or scratch lining of fuel tank. If lining is broken, fuel penetrates and activates self-sealing layers. Activated layers swell and trap fuel. Activated green spongy material also contaminates fuel system. This makes it necessary to replace fuel tank and flush fuel system.

2. Install packing (2) and check valve (3) set in tee (4).
3. Connect hose (5).

INSPECT**FOLLOW-ON MAINTENANCE:**

Perform vent system pressure test on affected tank (Task 10-117).
 Install main fuel tank forward access door (Task 10-52).
 Test main fuel tank (Task 10-22).
 Perform vent system flow test (Task 10-118).
 Perform test of pressure refueling system (Task 10-119) and fuel feed system (Task 10-120).
 Refuel helicopter (Task 1-51).
 Bleed fuel system (Task 10-121).
 Perform operational check of fuel system (left or right) (TM 55-1520-240-T).
 Inspect for leaks (Task 10-4).
 Close forward landing gear access panel (Task 2-2).

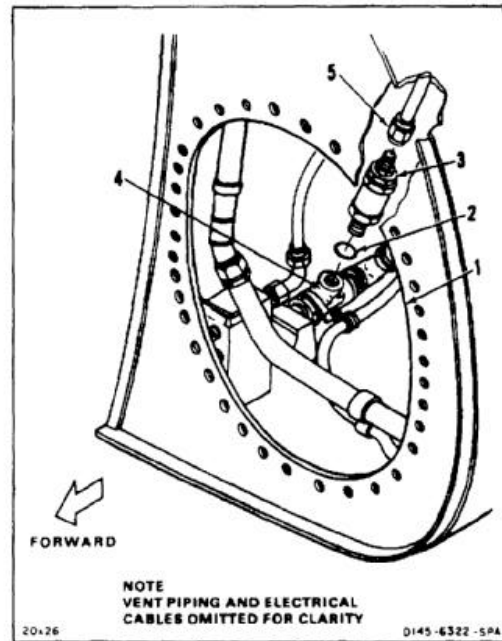

END OF TASK

10-248

10-51 REMOVE MAIN FUEL TANK FORWARD BOOST PUMP AND CHECK VALVE**10-51****INITIAL SETUP****Applicable Configurations:**

All

Tools:

Aircraft Mechanic's Tool Kit, NSN 51 80-00-323-4692
 Wrench, Open End, 1-1/2 Inch
 Wrench, Open End, 1-7/8 Inch
 Grounded Container, 2 Quart

Materials:

Barrier Material (E80)
 Tape (E388)
 Paper Tags (E264)
 Cloths (E120)
 Gloves (E184.1)

Personnel Required:

Medium Helicopter Repairer

Equipment Condition:

Battery Disconnected (Task 1-39)
 Electrical Power Off
 Helicopter Grounded (Task 1-29)
 Forward Landing Gear Access Panel Opened (Task 2-2)
 Main Tank Defueled (Task 10-34 or 10-35)
 Main Fuel Tank Purged (Task 10-2)
 Tee Fitting Removed (No. 1 Tank) (Task 10-55
 (Without **82**) or 10-55.1 (With **82**))
 Cross Fitting Removed (No. 2 Tank) (Task 10-57)

General Safety Instructions:**WARNING**

All regulations and instructions
 for handling fuels shall be strictly
 observed.

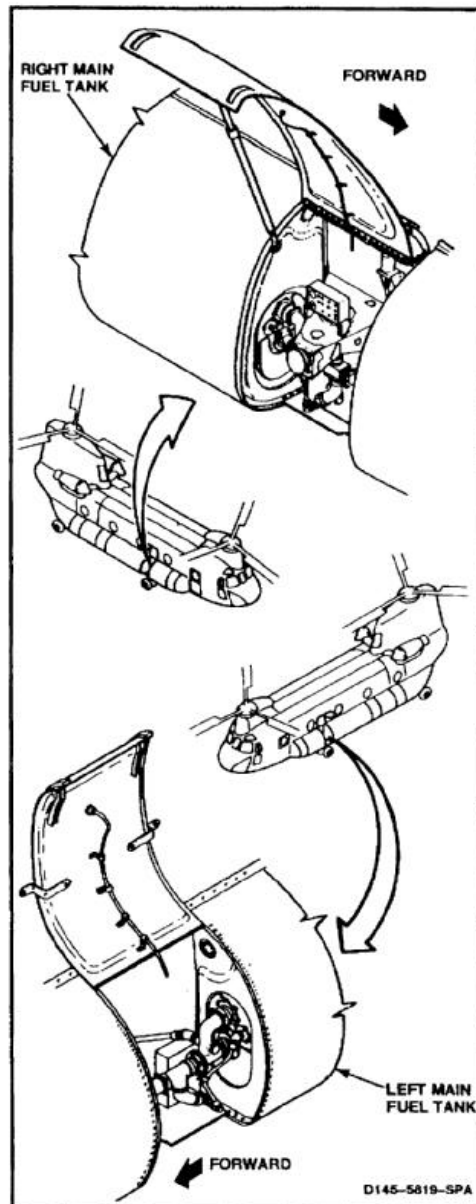

NOTE

Procedure is same to remove forward boost pump and check valve from No. 1 or No. 2 main fuel tank. Removal of No. 1 (left) boost pump and check valve is shown here.

REMOVE TANK FORWARD ACCESS DOOR

1. Disconnect electrical connector (1) from receptacle (2). Remove bolt (3) and washer (4) at clip (5). Remove the clip and loosely install the bolt and washer.



When disconnecting fuel hoses from forward access door, do not allow fittings to turn. Otherwise, fittings can fail and cause fuel blockage.

2. While holding fitting (6) with a wrench, disconnect hose (7). Catch spilled fuel. Use grounded container. Plug hose and cap fitting. Wear gloves (E184.1).
3. While holding fitting (8) with a wrench, disconnect hose (9).
4. Remove conical seal (10) from between fitting (8) and hose (9). Plug hose and cap the fitting.
5. Remove four bolts (11), washers (12), and nuts (13) from each flange of manifold (14).
6. Remove clip (15) from the lower flange of manifold (14).
7. Remove manifold (14), with gaskets (16) and (17).

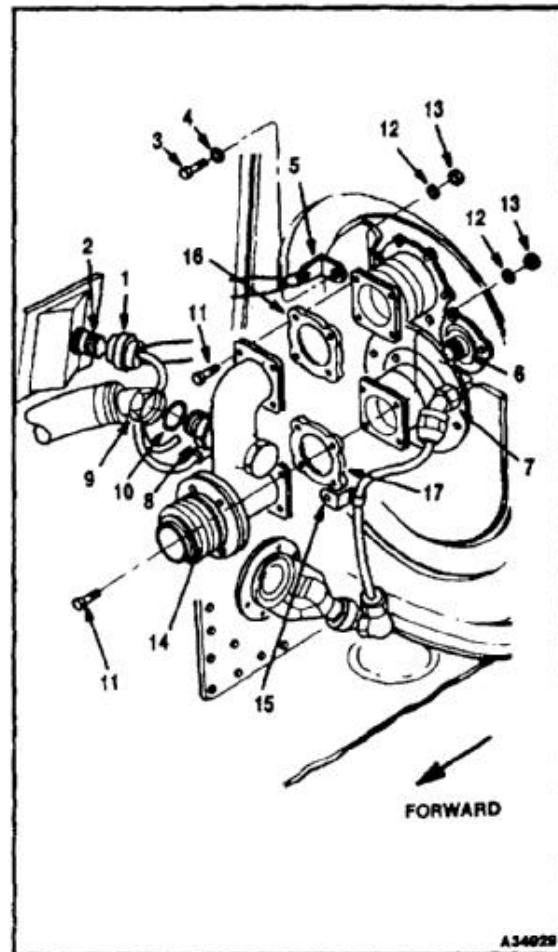

10-51 REMOVE MAIN FUEL TANK FORWARD BOOST PUMP AND CHECK VALVE (Continued) 10-51

8. Tag two electrical plugs (18 and 19). Remove lockwire and disconnect two plugs.
9. Remove lockwire and loosen two locknuts (20 and 21).
10. Remove 30 bolts (22), washers (23), and bracket (24). Tie back cables (25). Use tape (E388).
11. Move access door (26) from tank for access to inside of door.

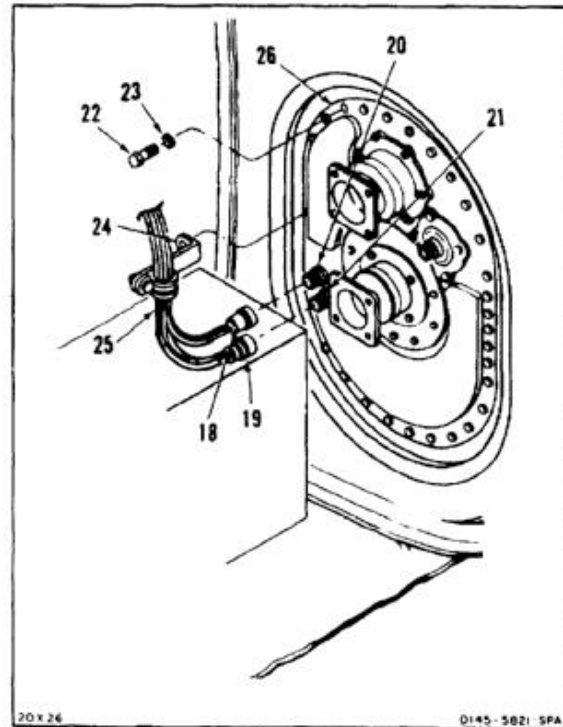

CAUTION

Do not puncture or scratch lining of fuel tank. If lining is broken, fuel penetrates and activates self-sealing layers. Activated layers swell and trap fuel. Activated green spongy material also contaminates fuel system. This makes it necessary to replace fuel tank and flush fuel system.

12. Disconnect hose (27). Plug and tag hose and cap nipple (28).
13. Disconnect hose (29). Cap hose and plug ring nut (30).
14. Disconnect and tag two hoses (31 and 32). Plug hoses and cap nipples (33 and 34).
15. Remove locknuts (20 and 21).
16. Remove electrical cables (35 and 36) from holes (37 and 38) in access door (26). Tag cables.
17. Remove access door (26) and gasket (39).

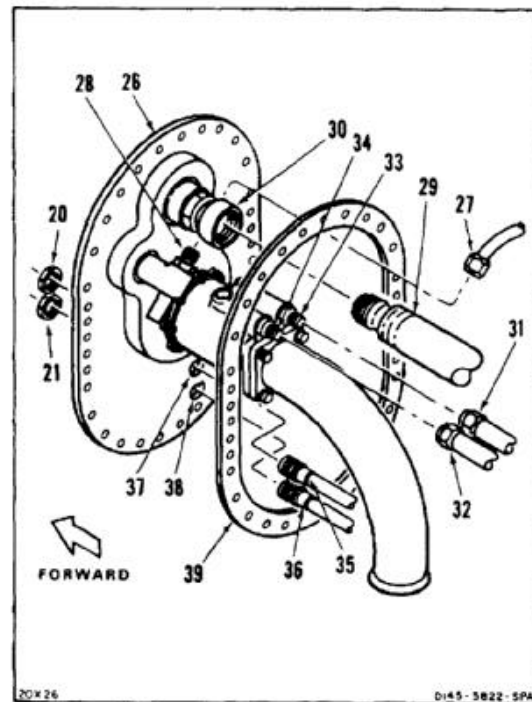

REMOVE FORWARD BOOST PUMP

18. Remove lockwire and disconnect electrical connector (40) from boost pump (41). Tag connector.
19. Disconnect hoses (42 and 43) from boost pump (41). Cap boost pump and plug hoses. Tag hoses.
20. Remove bolt (44), washer (45), nut (46).
21. Remove four bolts (47) and washers (48).
22. Maneuver boost pump (41) from pump bracket (49). Remove boost pump.
23. Cover access hole in tank (50) with barrier material (E80) and tape (E388).
24. Wipe up spilled fuel. Use cloths (E120). Wear gloves (E184.1).

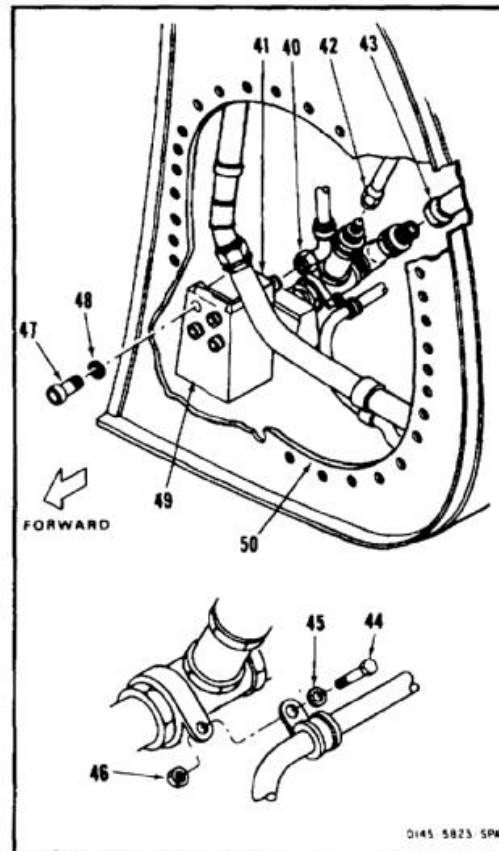

25. Loosen locknut (51) with wrench on flats of tee (52). Remove tee from pump nipple (53). Plug tee.
26. Remove packing (54) and locknut (51). Cap nipple (53).

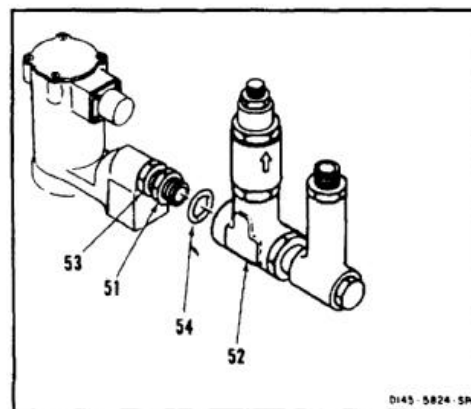

REMOVE CHECK VALVE

27. Loosen locknut (56).
28. With wrench on flats of tee (53), remove check valve (57) from tee.
29. Remove packing (58). Plug tee.
30. Remove locknut (56).

FOLLOW-ON MAINTENANCE:

None

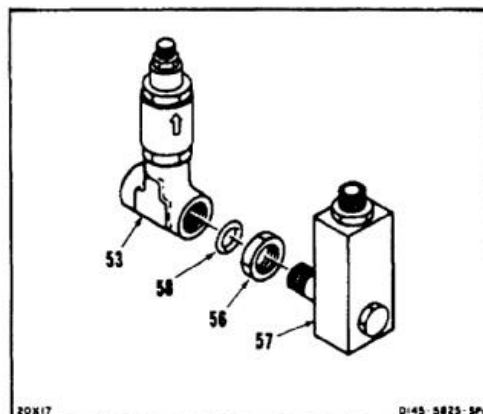

END OF TASK

INITIAL SETUP

Applicable Configurations:

All

Tools:

Aircraft Mechanic's Tool Kit, NSN 5180-00-323-4692
 Torque Wrench, 30 to 150 Inch-Pounds
 Torque Wrench, 700 to 1600 Inch-Pounds

Materials:

Lockwire (E231)
 Grease (E458)
 Dry Cleaning Solvent (E162)
 Cloths (E120)
 Gloves (E186)
 Petrolatum (E274)

Parts:

Gaskets
 Packings

Personnel Required:

Medium Helicopter Repairer
 Inspector

References:

TM 55-1520-240-23P

General Safety Instructions:**WARNING**

All regulations and instructions for handling fuels shall be strictly observed.

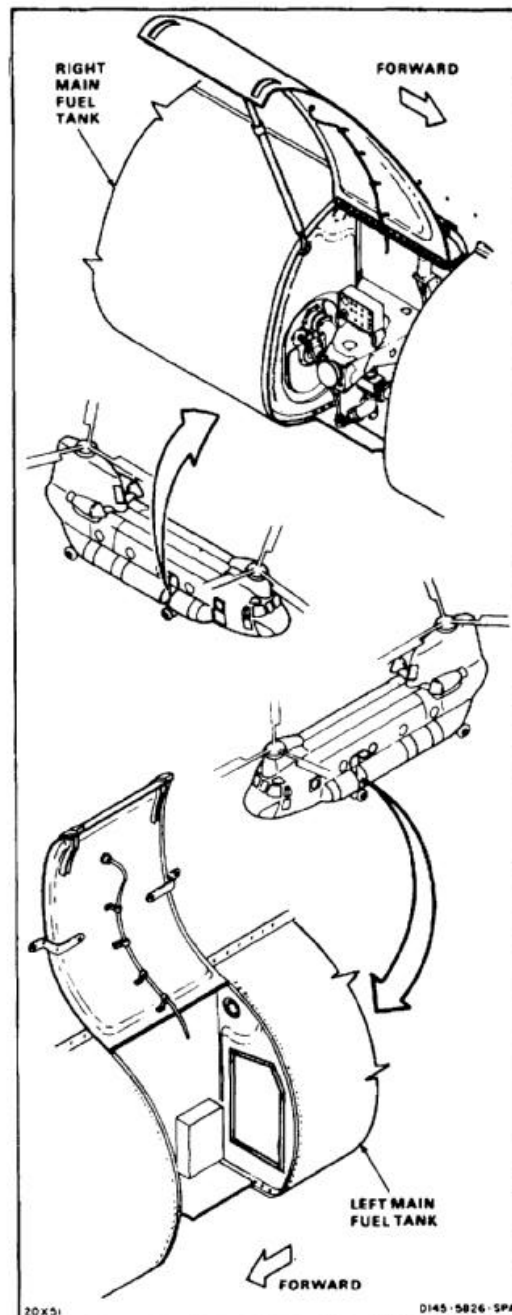

NOTE

Procedure is same to install forward boost pump and check valve in No. 1 or No. 2 main fuel tank. Installation of No. 1 (left) boost pump and check valve is shown here.

INSTALL FORWARD CHECK VALVE

1. Install locknut (1) and packing (2) on check valve (3).
2. Remove plug from tee (4). With wrench on flats of tee, install tee on check valve (3).
3. Align check valve (3) and tee (4) as shown. Tighten locknut (1).

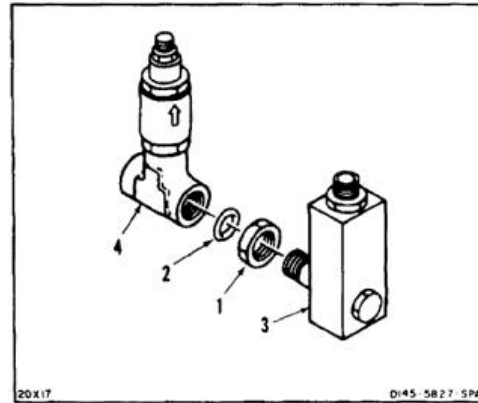
**INSTALL FORWARD BOOST PUMP**

4. Remove cap from nipple (5). Install locknut (6) and packing (7) on nipple.
5. Remove plug from tee (4). Apply grease (E458) to thread of nipple (5). Install tee on nipple.
6. Align tee (4) and boost pump (8) as shown. Hold flats on tee with wrench. Tighten locknut (6).

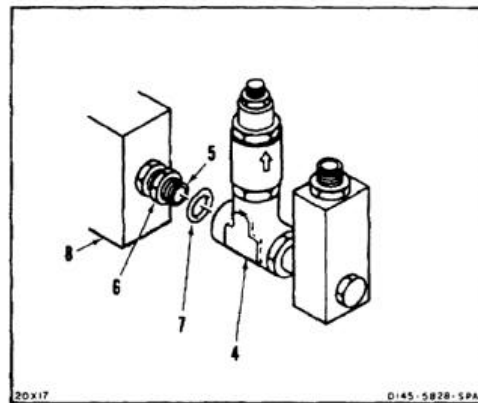

WARNING

Dry cleaning solvent (E162) is flammable and toxic. It can irritate skin and cause burns. Use only in well-ventilated area, away from heat and open flame. In case of contact, immediately flush skin or eyes with water for at least **15 minutes**. Get medical attention for eyes.

7. Remove barrier material and tape from access hole in tank (9). Clean tape residue from tank. Use dry cleaning solvent (E162) and cloths (E120). Wear goggles to protect eyes. Wear gloves (E186).

CAUTION

Do not puncture or scratch lining of fuel tank. If lining is broken, fuel penetrate and activates self-sealing layers. Activated layers swell and trap fuel. Activated green spongy material also contaminates fuel system. This makes it necessary to replace fuel tank and flush fuel system.

8. Position boost pump (8) on bracket (10). Install four bolts (11) and washers (12).
9. Position spacer (13) and cable clamp (14). Install bolt (15), washer (16), and nut (17).
10. Remove caps from boost pump (8) and plugs and tags from hoses (18 and 19). Connect hoses to pump. Torque hose connector (19) to **1125 inch-pounds**.
11. Connect electrical connector (20) to boost pump (8). Remove tag. Lockwire connector to pump. Use lockwire (E231).

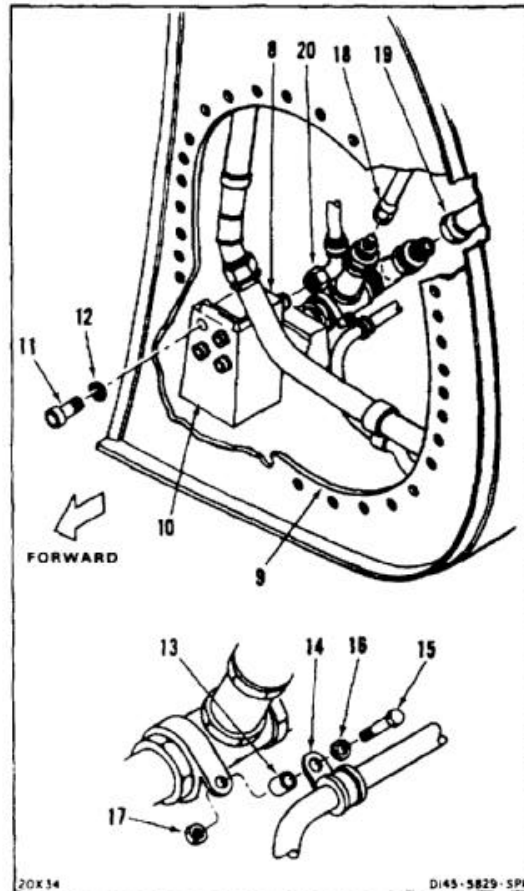

INSTALL TANK FORWARD ACCESS DOOR**NOTE**

Coat preformed packings with petrolatum (E274).

12. Position gasket (21) and access door (22) next to access hole in tank (9). Remove tag from electrical receptacle (23). Check that packing is installed on receptacle. Insert receptacle through hole (24). Check that packing is installed on receptacle, install key washer (25.1), install and hand tighten locknut (25) on receptacle.
13. Remove tag from electrical receptacle (26). Insert receptacle through hole (27). Check that packing is installed on receptacle. Install and hand tighten locknut (28) on receptacle.
14. Remove tag and plug from hose (29) and cap from nipple (30). Connect hose to nipple.
15. Remove tag and plug from hose (31) and cap from nipple (32). Connect hose to nipple.
16. Remove cap from hose (33) and plug from ring nut (34). Connect ring nut to hose. Tighten ring nut with a strap until it is bottomed against hose fitting. Check that ring nut fits against hose fitting with a gap of no more than **0.050 inch**.
17. Remove tag and plug from hose (35) and cap from nipple (36). Connect hose to nipple.
18. Position gasket (21) and access door (22) against tank (9).
19. Position electrical cable (37) and bracket (38) as shown. Install 30 bolts (39) and washers (40). Torque bolts to **70 inch-pounds**.
20. Tighten two locknuts (25 and 28). Torque to **100 to 125 inch-pounds** and lockwire (E231). Bend tabs on keywasher (25.1).
21. Connect electrical plug (41) to receptacle (23). Remove tag.
22. Connect electrical plug (42) to receptacle (26). Remove tag.
23. Lockwire connectors (41 and 42). Use lockwire (E231).

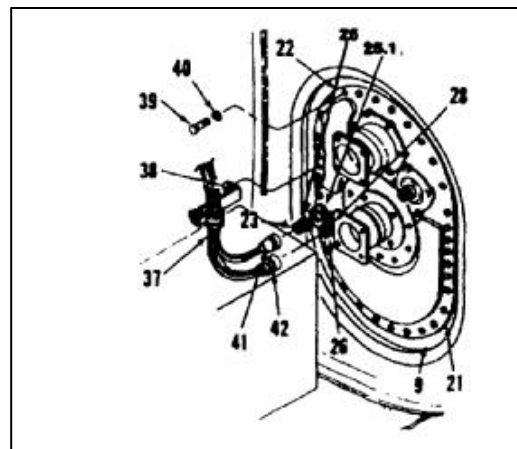
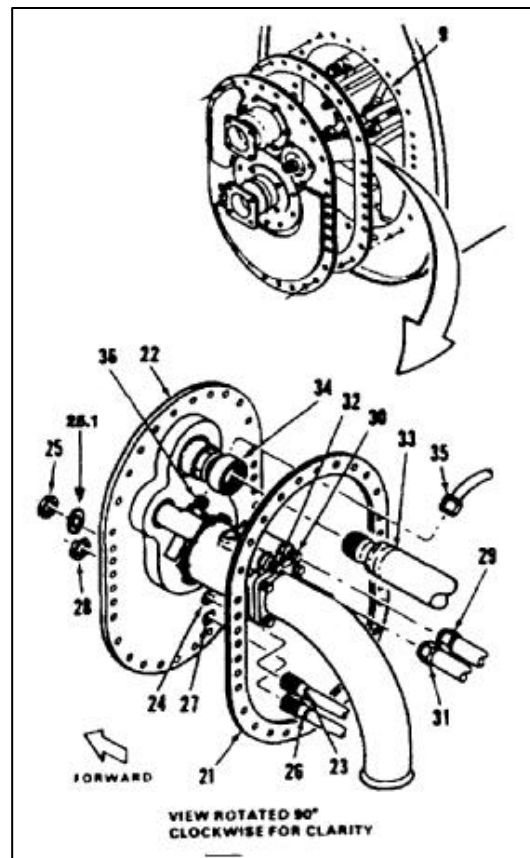

24. Position manifold (43) with gaskets (44 and 45) against breakaway fittings (46 and 47).
25. Install four bolts (48), washers (49), and nuts (50) at top of flange of manifold (43).
26. Position hose clamp clip (51) against the lower flange of manifold (43) at the lower outboard hole. Install four bolts (52), washers (53), and nuts (54).



When connecting fuel hoses to forward access panel, do not allow fittings to turn. Otherwise, fittings can fail and cause fuel blockage.

27. Remove plug from hose (55) and cap from fitting (56). Install conical seal (57) in hose. Hold fitting with wrench. Connect hose.
28. Remove plug from hose (58) and cap from fitting (59). Hold fitting with wrench. Connect hose.
29. Connect electrical connector (60) to receptacle (61).
30. Remove one bolt (39) and washer (40) from access door (22) to install lanyard clip (62) on the door. Position the clip against the door and install the bolt and washer. Torque the bolt to **70 inch-pounds**.

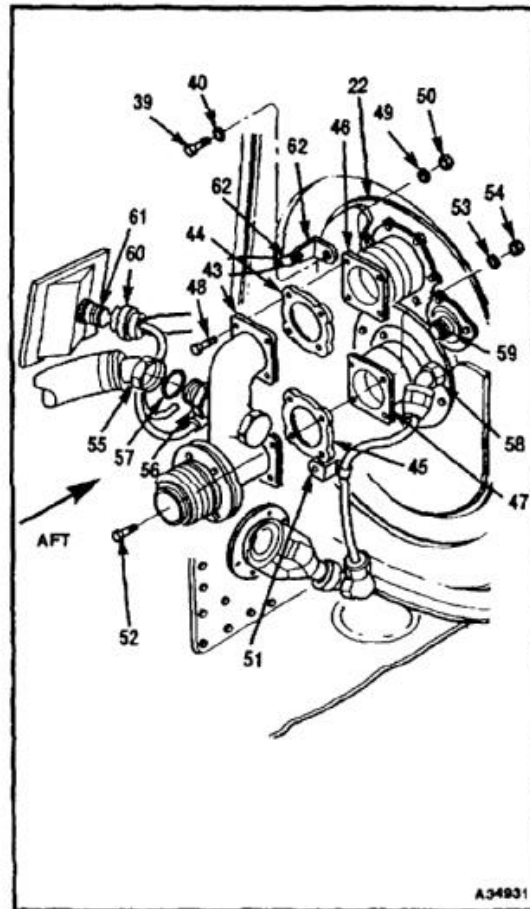

INSPECT

FOLLOW-ON MAINTENANCE:

- Install tee fitting (No. 1 Tank) (Task 10-56 (Without **82**) or 10-56.1 (With **82**)).
- Install cross fitting (No. 2 Tank) (Task 10-58).
- Perform vent system flow test (Task 10-118).
- Test main fuel tank (Task 10-22).
- Perform test of pressure refueling system (Task 10-119) and fuel feed system (Task 10-120).
- Refuel helicopter (Task 1-51).
- Bleed fuel system (Task 10-121).
- Perform operational check of appropriate fuel system (TM 55-1520-240-T).
- Close forward landing gear panel (Task 2-2).

END OF TASK

INITIAL SETUP

Applicable Configurations:

All

Tools:

Aircraft Mechanic's Tool Kit, NSN 5180-00-323-4692
 Wrench, Open End, 1-1/2 Inch
 Wrench, Open End, 1-1/8 Inch
 Strap Wrench
 Grounded Container, 2 Quart or Equivalent

Materials:

Barrier Material (E80)
 Tape (E388)
 Paper Tags (E264)
 Cloths (E135)

Personnel Required:

Medium Helicopter Repairer

Equipment Condition:

Battery Disconnected (Task 1-39)
 Electrical Power Off
 Helicopter Grounded (Task 1-29)
 Aft Intertank Pod Panel Lowered (Task 2-185)
 Main Tank Defueled (Task 10-34 or 10-35)
 Main Fuel Tank Purged (Task 10-2)

General Safety Instructions:

WARNING

All regulations and instructions for handling fuels shall be strictly observed.

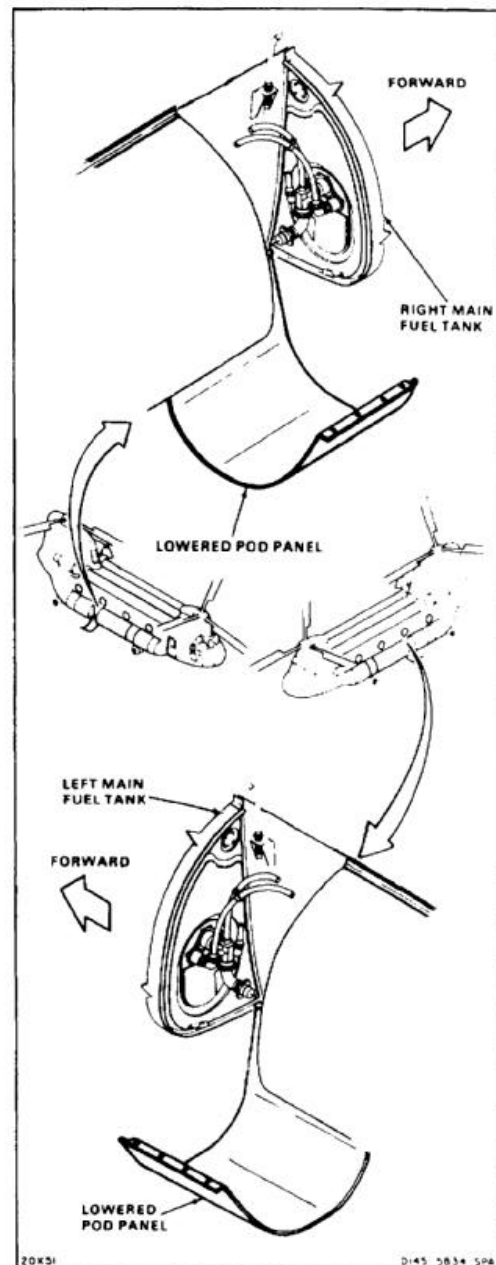

NOTE

Procedure is same to remove aft boost pump and check valve from No. 1 or No. 2 main fuel tank. Removal of No. 1 (left) boost pump and check valve is shown here.

REMOVE TANK AFT ACCESS DOOR

1. Tag two connectors (1 and 2). Remove lockwire and disconnect two connectors. Tape wires and connectors to fuselage (3) for temporary stowage. Use tape (E388).



When disconnecting fuel hoses from aft access door, do not allow fittings to turn. Otherwise, fittings can fail and block fuel flow.

2. Hold fitting (4) with wrench. Disconnect vent hose (5). Plug hose and cap fitting. Tape hose to fuselage (3) for stowage. Tag hose.
3. Hold fitting (7) with wrench. Disconnect hose (6). Remove conical seal (6.1) from hose fitting. Plug hose and cap fitting. Tape hose to fuselage (3) for stowage. Tag hose.
4. Remove hoses (8). Plug hose and cap adapters (9 and 10). Tag hose.
5. Hold adapter (12) with wrench and disconnect hose (11). Remove conical seal (11.1) from hose fitting. Plug hose and cap adapter (12). Tape hose to fuselage (3) for stowage. Tag hose.
6. Remove four nuts (14), washers (13), and bolts (15).
7. Slide elbow (16) aft into union adapter (17). Remove gasket (18).
8. Remove four nuts (19), washers (20), and bolts (21).
9. Remove elbow (16) and gasket (22).

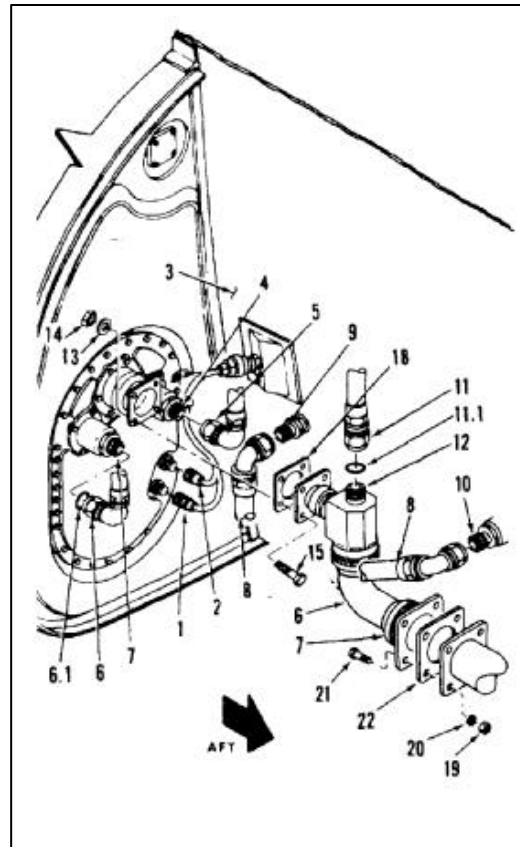

10-53 REMOVE MAIN FUEL TANK AFT BOOST PUMP AND CHECK VALVE (Continued)**10-53**

10. Remove lockwire and loosen two locknuts (23 and 24).
11. Remove 30 bolts (25) and washers (26).
12. Remove two brackets (27 and 28).
13. Move access door (29) from tank for access to inside of door.

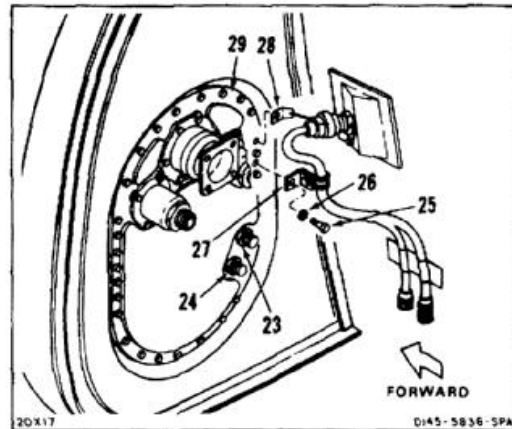
**REMOVE BOOST PUMP**

Do not puncture or scratch lining of fuel tank. If lining is broken, fuel penetrates and activates self-sealing layers. Activated layers swell and trap fuel. Activated green spongy material also contaminates fuel system. This makes it necessary to replace fuel tank and flush fuel system.

14. Tag and disconnect two hoses (30 and 31). Plug hoses and cap fittings (32 and 33).
15. Disconnect hose (34). Cap hose and plug ring nut (35).
16. Remove two locknuts (23 and 24).
17. Guide two receptacles (36 and 37) from holes (38 and 39) in access door (29).
18. Remove access door (29) and gasket (40).

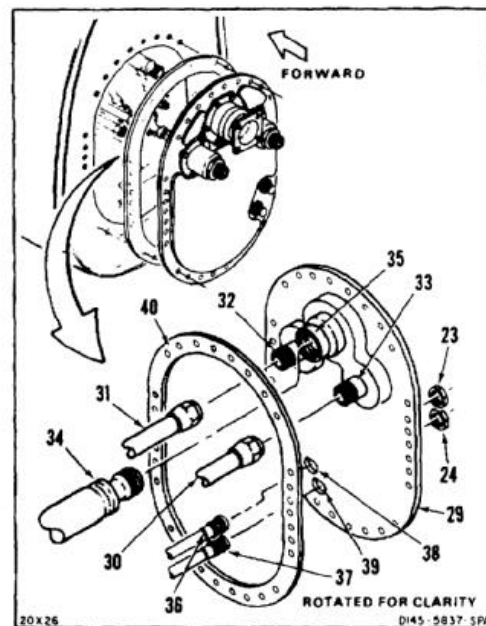

19. Remove lockwire and disconnect electrical connector (41) from boost pump (42).
20. Remove nut (43), two washers (44), spacer (45) and screw (48).
21. Disconnect hose connection (47). Cap boost pump (42) and plug hose.
22. Remove four bolts (48) and washers (49) and electrical lead (50).
23. Maneuver boost pump (42) from pump bracket (51). Remove boost pump.
24. Cover access hole in tank (52) with barrier material (E80) and tape (E388).
25. Wipe up spilled fuel. Use cloths (E135).

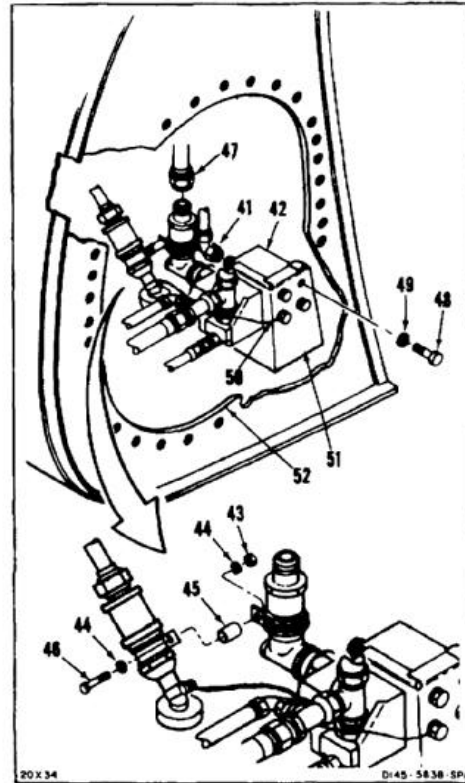
**REMOVE CHECK VALVE**

26. Loosen locknut (53) with wrench on flats of check valve (54) remove check valve.
27. Remove packing (55) and locknut (53) from valve (54). Cap valve and plug boost pump (42).

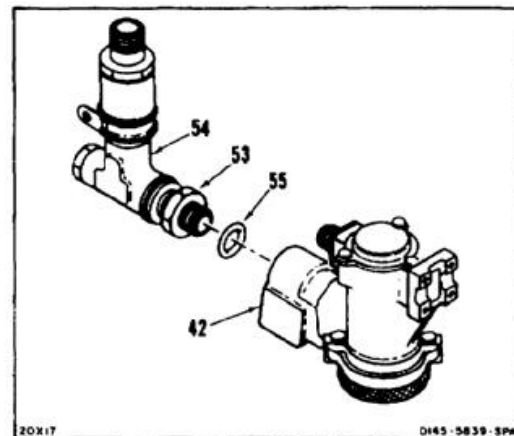
**FOLLOW-ON MAINTENANCE:**

None

END OF TASK

10-262

INITIAL SETUP

Applicable Configurations:

All

Tools:

Aircraft Mechanic's Tool Kit, NSN 5180-00-323-4692
 Torque Wrench, 30 to 150 Inch-Pounds
 Torque Wrench, 700 to 1600 Inch-Pounds
 Wrench, Open End, 1-1/2 Inch
 Wrench, Open End, 1-7/8 Inch

Materials:

Lockwire (E231)
 Grease (E458)
 Dry Cleaning Solvent (E162)
 Gloves (E186)

Parts:

Gaskets
 Packing

Personnel Required:

Medium Helicopter Repairer
 Inspector

References:

TM 55-1520-240-23

General Safety Instructions:**WARNING**

All regulations and instructions
 for handling fuels shall be strictly
 observed.

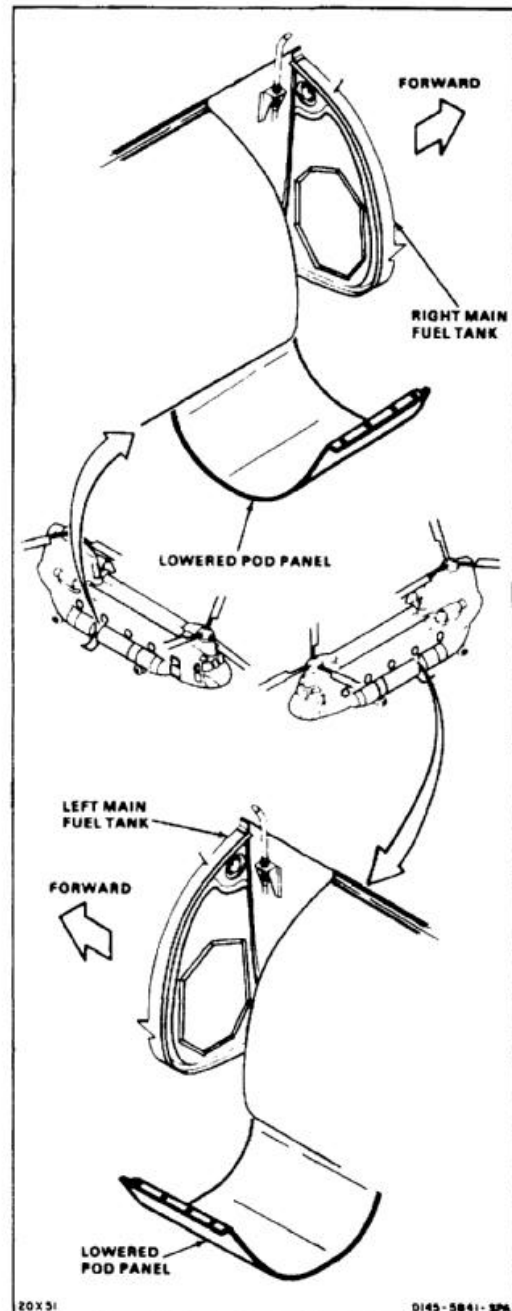

NOTE

Procedure is same to install aft boost pump and check valve in No. 1 or No. 2 main fuel tank. Installation of No. 1 (left) boost pump and check valve.

INSTALL CHECK VALVE

1. Remove plug from boost pump (1) and cap from nipple (2) of check valve (3).
2. Install locknut (4) and packing (5) on check valve (3). Apply grease (E458) to thread of nipple (2). Install check valve on fuel boost pump (1).
3. Align check valve (3) with boost pump (1) as shown. Tighten locknut (4).

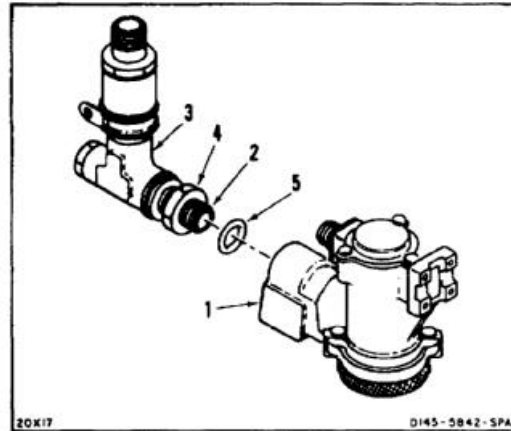

INSTALL AFT BOOST PUMP**WARNING**

Dry cleaning solvent (E162) is flammable and toxic. It can irritate skin and cause burns. Use only in well-ventilated area, away from heat and open flame. In case of contact, immediately flush skin or eyes with water for at least **15 minutes**. Get medical attention for eyes.

4. Remove barrier material and tape from access hole in tank (6). Clean tape residue from face of tank. Use dry cleaning solvent (E162) and cloths (E120). Wear goggles to protect eyes. Wear gloves (E186).

CAUTION

Do not puncture or scratch lining of fuel tank. If lining is broken, fuel penetrates and activates self-sealing layers. Activated layers swell and trap fuel. Activated green spongy material also contaminates fuel system. This makes it necessary to replace fuel tank and flush fuel system.

5. Position boost pump (1) on bracket (7). Position electrical lead (8) on bracket. Install four bolts (9) and washers (10).
6. Position spacer (11) and cable clamp (12). Install bolt (13), washers (14), and nut (15).
7. Remove caps from boost pump (1) and plugs from tube (16). Connect tube to boost pump. Torque tube connector to **1125 inch-pounds**.
8. Connect electrical connector (17) to boost pump (1). Lockwire connector to pump. Use lockwire (E233).

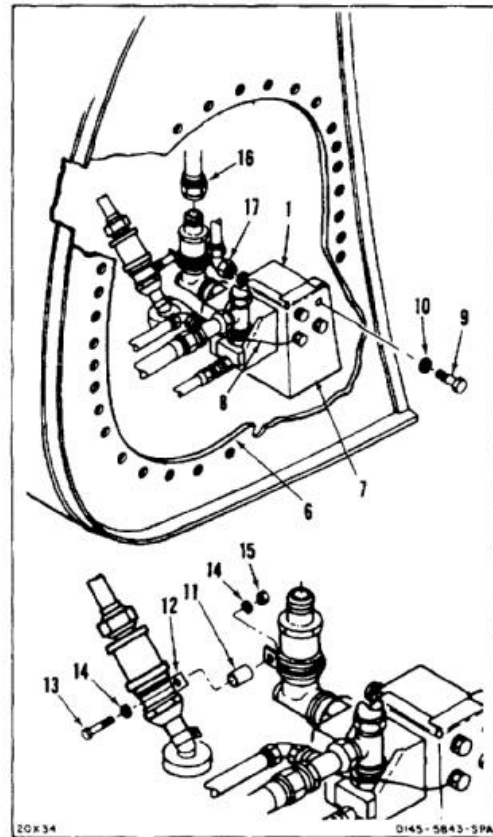
INSPECT

INSTALL TANK AFT ACCESS DOOR

9. Position gasket (18) and access door (19) next to access hole in tank (6).

NOTE

Coat preformed packings with petrolatum (E274).

10. Position electrical cable (20). Insert receptacle (21) through hole (22). Check that packing is installed on receptacle. Install keywasher (23.1). Install and hand tighten locknut (23) on receptacle.
11. Position electrical cable (24). Insert receptacle (25) through hole (26). Check that packing is installed on receptacle. Install and hand tighten locknut (27) on receptacle.
12. Remove plug from ring nut (28) and cap from hose (29). Connect hose to ring nut. Tighten ring nut with a strap wrench until it is bottomed against hose fitting. Check that ring nut fits against hose fitting with a gap of no more than **0.050 inch**.



Incorrect connection of fuel and vent hoses will not be evident during gravity refueling, only during pressure refueling. Airframe damage will occur.

13. Remove tag and plug from vent hose (30) and cap from fitting (31). Connect hose to fitting.
14. Remove tag and plug from fuel hose (32) and cap from fitting (33). Connect hose to fitting.

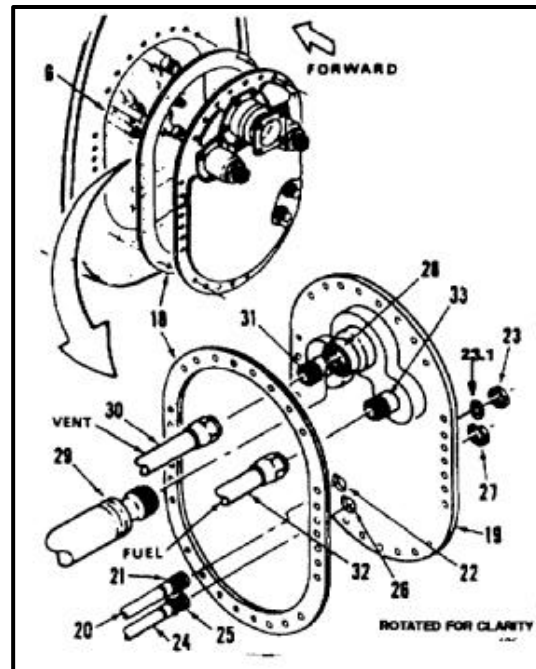

10-54 INSTALL MAIN FUEL TANK AFT BOOST PUMP AND CHECK VALVE (Continued)**10-54**

15. Position gasket (18) and access door (19) against tank (6).
16. Position two brackets (34 and 35) as shown. Install 30 bolts (36) and washers (37). Torque bolts to **70 inch-pounds**.
17. Tighten locknuts (23 and 27). Torque to **100 to 125 inch-pounds**. Install lockwire (E231). Bend tabs on key washer (23.1).

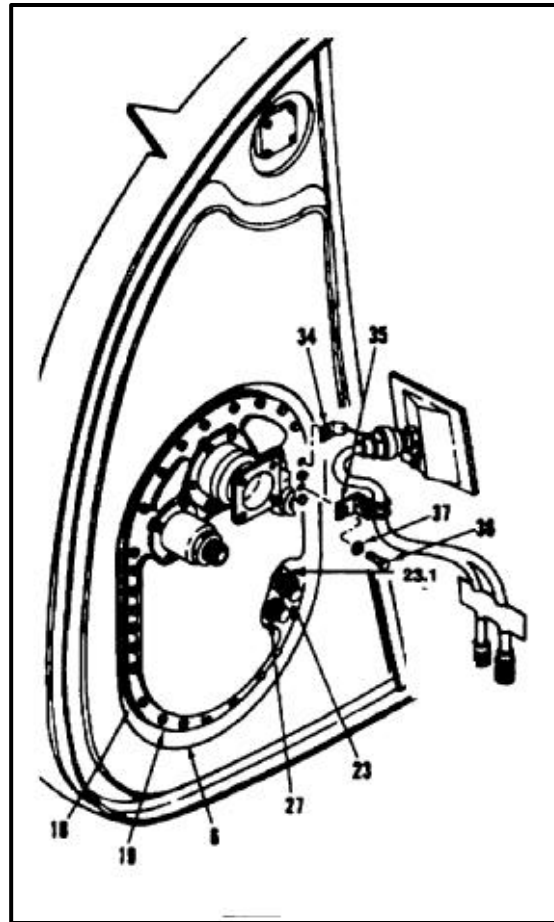

18. Position elbow (38) and gasket (39). Install four bolts (40), washers (41), and nuts (42),
19. Position gasket (43). Slide elbow (38) forward from union adapter (44). Install four bolts (45), washers (46), and nuts (47).



When connecting fuel hoses to aft access door, do not allow fittings to turn. Otherwise, fitting can fail and block fuel flow.

20. Remove cap from adapter (48). Remove tape and plug from hose (49). Install conical seal (49.1) in hose fitting. Hold adapter with wrench. Connect hose.
21. Remove cap from adapter (50). Remove tape and plug from hose (51). Install conical seal (51.1) in hose fitting. Hold adapter with wrench. Connect hose.
22. Remove caps from two adapters (52 and 53) and plugs from two connectors on hose (54). Position and connect hose to adapters.
23. Remove cap from adapter (55). Remove tape and plug from hose (56). Connect hose to adapter.
24. Remove tape from two electrical connectors (57 and 58).
25. Connect connector (57) to receptacle (59). Remove tag.
26. Connect connector (58) to receptacle (60). Remove tag.

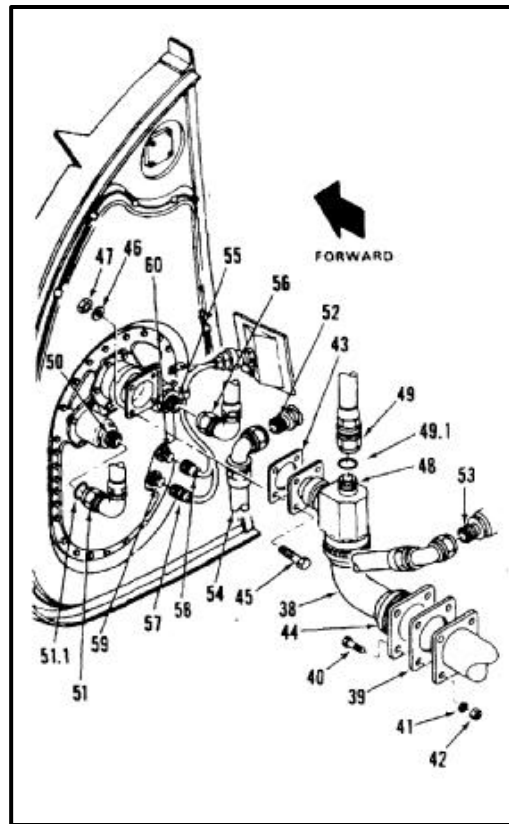

INSPECT

FOLLOW-ON MAINTENANCE:

- Perform vent system flow test (Task 10-118).
- Test main fuel tank (Task 10-22).
- Perform test of pressure refueling system (Task 10-119) and fuel feed system (Task 10-120).
- Refuel helicopter (Task 1-51).
- Bleed fuel system (Task 10-121).
- Perform operational check of appropriate fuel system (TM 55-1520-240-T).
- Inspect for leaks (Task 10-4).
- Close and latch aft intertank pod panel (Task 2-188).

END OF TASK

10-55 REMOVE MAIN TANK (NO. 1 SYSTEM) FUEL LEVEL SHUTOFF VALVE**10-55****INITIAL SETUP****Applicable Configurations:**Without **82****Tools:**

Aircraft Mechanic's Tool Kit, NSN 5180-00-323-4692
 Strap Wrench
 Grounded Container, 2 Quart or Equivalent

Materials:

Cloths (E135)
 Barrier Material (E80)
 Tape (E388)

Personnel Required:

Medium Helicopter Repairer

Equipment Condition:

Battery Disconnected (Task 1-39)
 Electrical Power Off
 Helicopter Grounded (Task 1-29)
 Forward Landing Gear Access Door Opened (Task 2-2)
 All Tanks on Left Side of Helicopter Defueled and Both Crossover Valves Closed (Task 10-34 or 10-35)

General Safety Instructions:**WARNING**

All regulations and instructions for handling fuels shall be strictly observed.

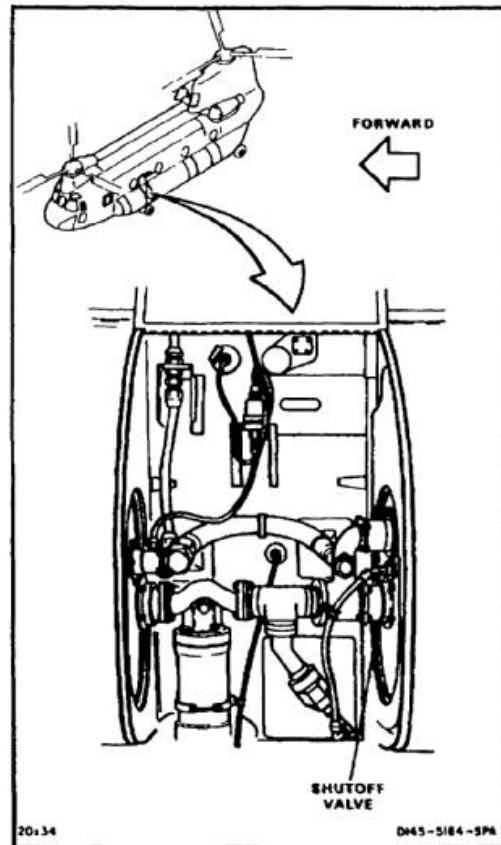

1. Loosen three ring nuts (1) on tee (2). Use strap wrench.
2. Loosen ring nut (3) on elbow (4). Use strap wrench.
3. Remove four bolts (5), nuts (6), and washers (7).
4. Remove tube (8), tee (2) and elbow (4). Catch spilled fuel. Use grounded container. Separate tube and elbow from tee.
5. Remove gasket (9).

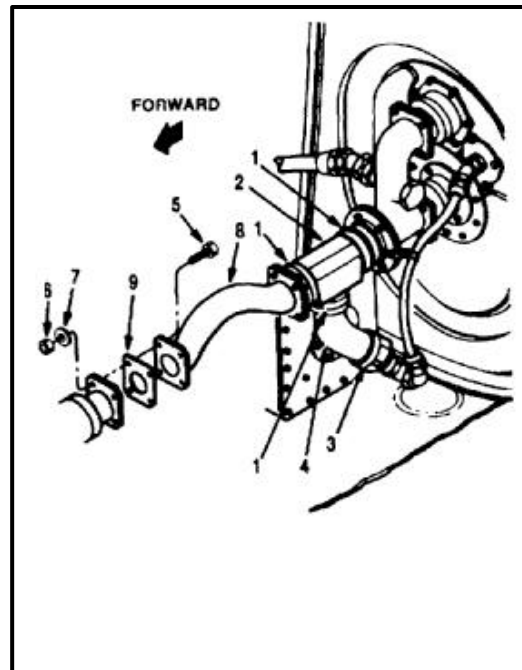

6. Remove bolt (10), two washers (11), and nut (12) from hose clamp (13). Disconnect clamp.
7. Disconnect hose (14). Remove conical seal (14.1) from hose fitting. Plug hose.
8. Remove four bolts (15), washers (16), and nuts (17).
9. Support manifold (18). Remove four bolts (19), washers (20), nuts (21), and manifold.

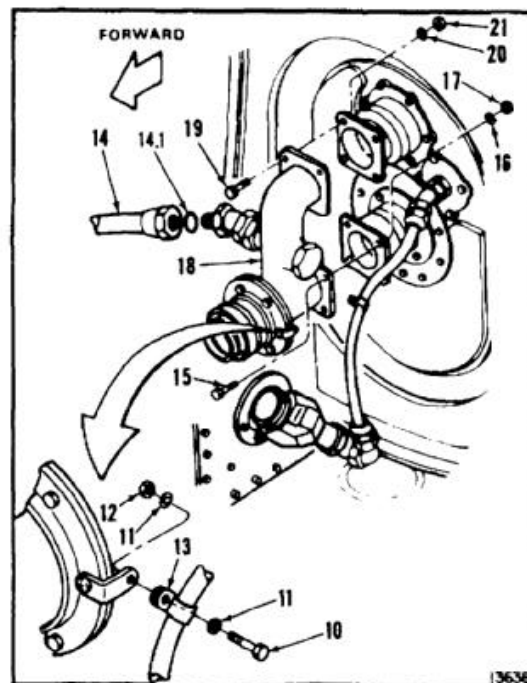

10-55 REMOVE MAIN TANK (NO. 1 SYSTEM) FUEL LEVEL SHUTOFF VALVE (Continued)

10. Remove two gaskets (22). Plug holes in four fittings (23).

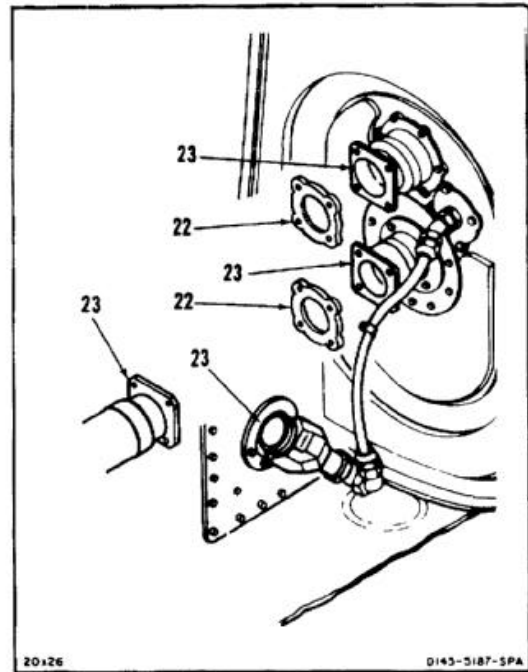

11. Remove four packings (24) from elbow (4), tube (8), and manifold (18).

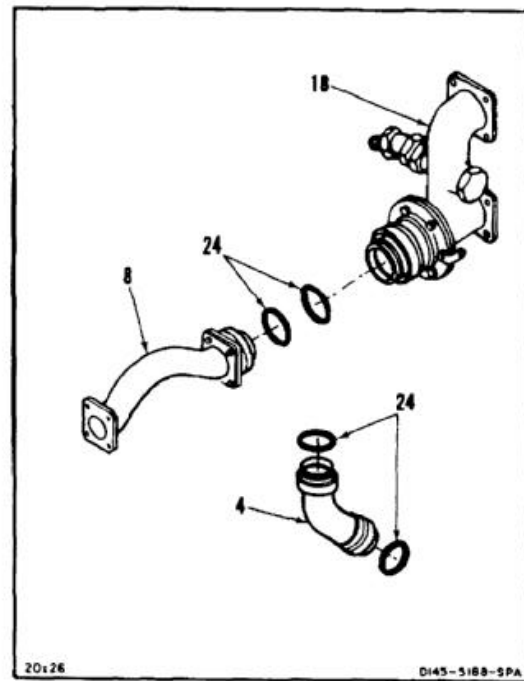

12. Remove 10 bolts (25) and washers (26).
13. Withdraw fuel valve (27) from tank (28) for access to two hose connections (29). Disconnect hose connections.
14. Maneuver fuel valve (27) from tank (28). Seal hole in tank. Use barrier material (E80) and tape (E388).
15. Remove packing (30) from mounting flange of fuel valve (27).

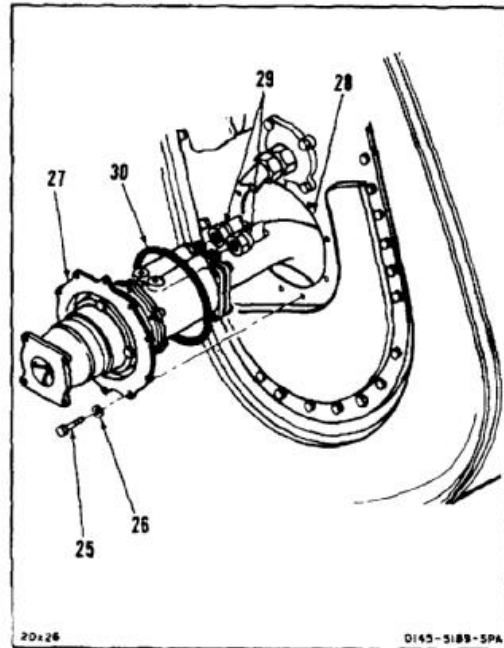

16. Remove four bolts (31) and washers (32). Remove fitting (33) and packing (34) from valve (27).
17. Remove four bolts (35), washers (36) and nuts (37). Remove tube (38).
18. Clean up spilled fuel. Use cloths (E135).

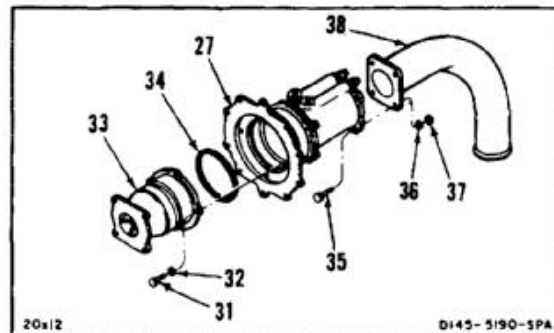
**FOLLOW-ON MAINTENANCE:**

None

END OF TASK

10-272

10-55.1 REMOVE MAIN TANK (NO. 1 SYSTEM) FUEL LEVEL SHUTOFF VALVE

10-55.1

INITIAL SETUP**Applicable Configurations:**With **82****Tools:**

Aircraft Mechanic's Tool Kit, NSN 5180-00-323-4692
 Strap Wrench
 Grounded Container, 2 Quart or Equivalent

Materials:

Cloths (E135)
 Barrier Material (E80)
 Tape (E388)

Personnel Required:

Medium Helicopter Repairer

Equipment Condition:

Battery Disconnected (Task 1-39)
 Electrical Power Off
 Helicopter Grounded (Task 1-29)
 Forward Left Landing Gear Access Door Opened
 (Task 2-2)
 All Tanks on Left Side of Helicopter Defueled and Both
 Crossover Valves Closed (Task 10-34 or 10-35)
 ERFS II Refueling Hose Removed (Task 10-55.2)

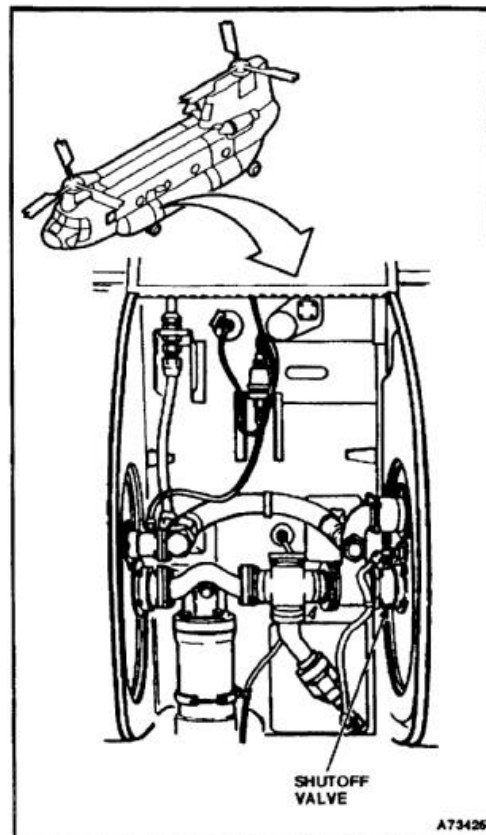
**General Safety Instructions:****WARNING**

All regulations and instructions
 for handling fuels shall be strictly
 observed.

1. Loosen three ring nuts (1) on fitting (2). Use strap wrench.
2. Loosen ring nut (3) on elbow (4). Use strap wrench.
3. Remove four bolts (5), nuts (6), and washers (7).
4. Remove tube (8), fitting (2), and elbow (4). Catch spilled fuel. Use grounded container. Separate tube (8) and elbow (4) from fitting (2).
5. Remove gasket (9).

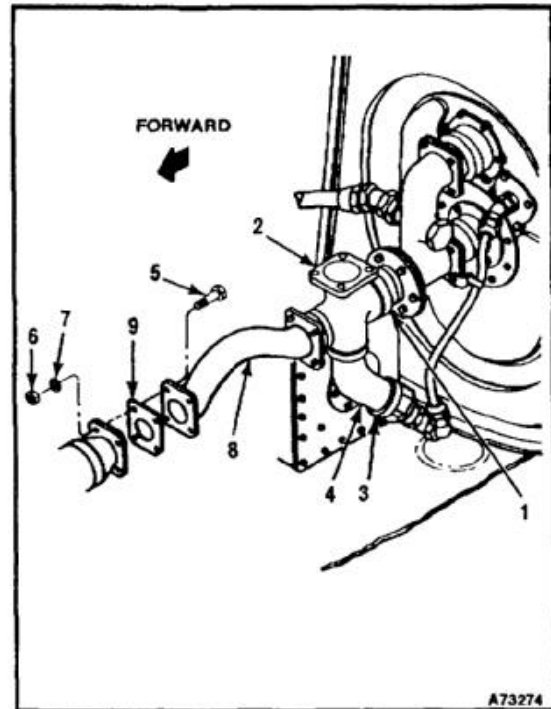

6. Remove bolt (10), two washers (11) and nut (12) from hose clamp (13). Disconnect clamp.
7. Disconnect hose (14). Remove conical seal (15) from hose fitting. Plug hose.
8. Remove four bolts (16), washers (17), and nuts (18).
9. Support manifold (19). Remove four bolts (20) washers (21), nuts (22), and manifold.

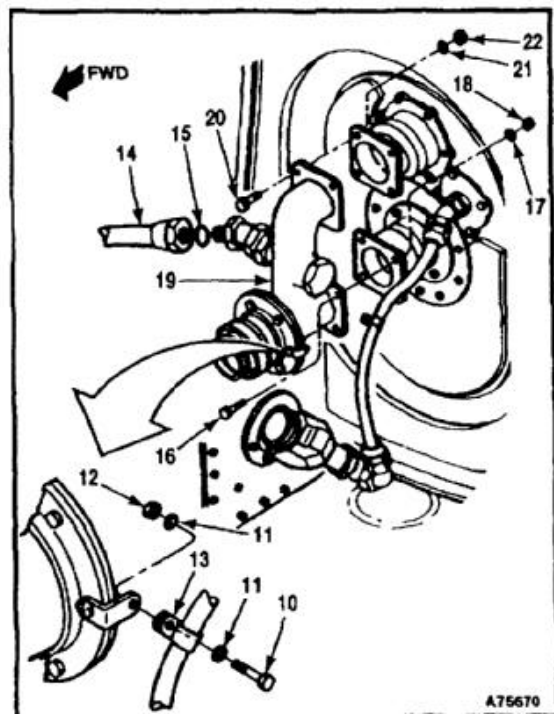

10-55.1 REMOVE MAIN TANK (NO. 1 SYSTEM) FUEL LEVEL SHUTOFF VALVE (Continued)

10-55.1

10. Remove two gaskets (23). Plug holes in four fittings (24).

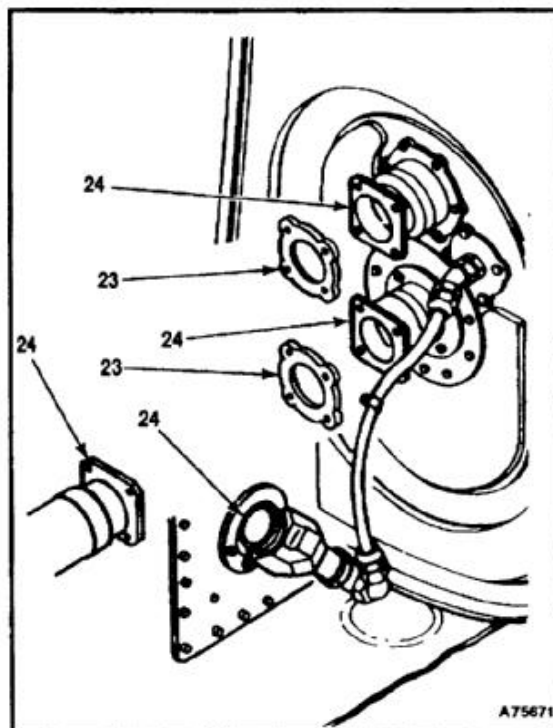

11. Remove four packings (25) from elbow (4), tube (8), and manifold (19).

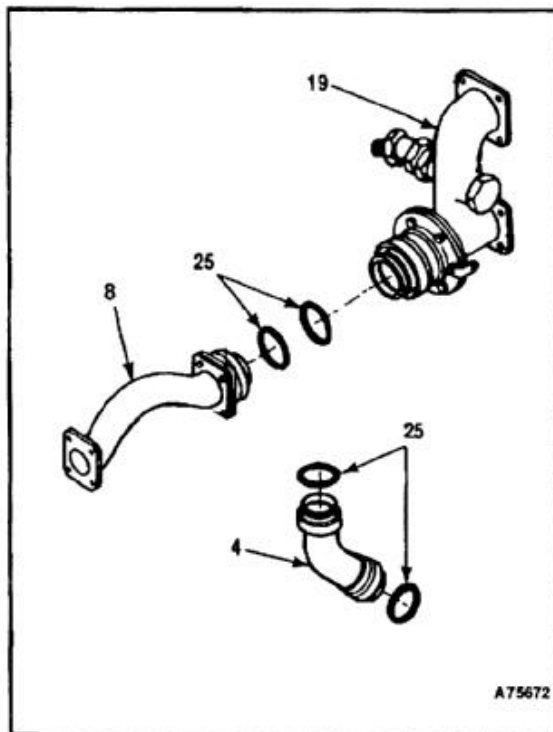

12. Remove 10 bolts (26) and washers (27).
13. Withdraw fuel valve (28) from tank (29) for access to two hose connections (30). Disconnect hose connections.
14. Maneuver fuel valve (28) from tank (29). Seal hole in tank. Use barrier material (E80) and tape (E388).
15. Remove packing (31) from mounting flange of fuel valve (28).

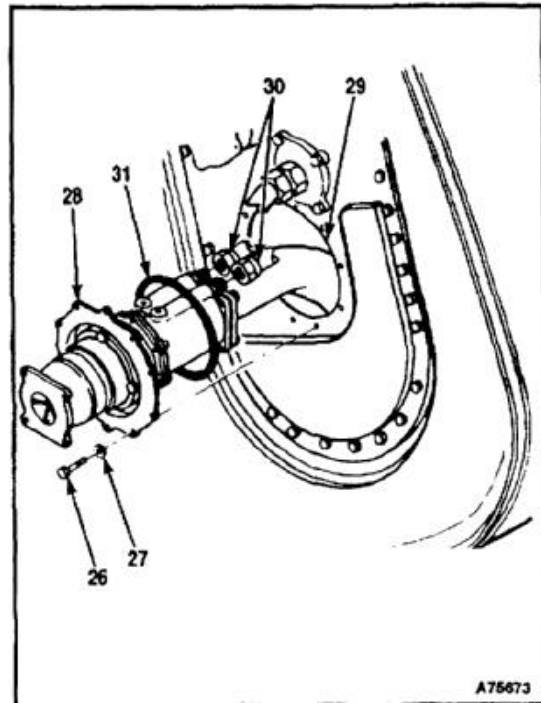

16. Remove four bolts (32) and washers (33). Remove fitting (34) and packing (35) from valve (28).
17. Remove four bolts (36), washers (37), and nuts (38). Remove tube (39).
18. Clean up spilled fuel. Use cloths (E135).

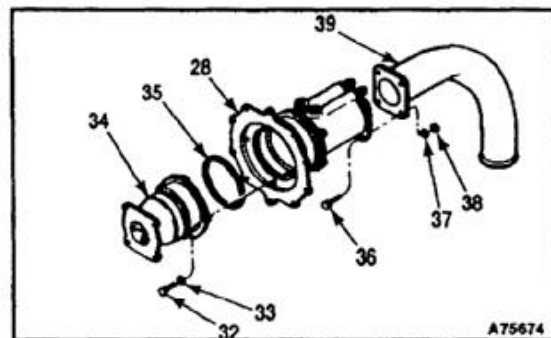
**FOLLOW-ON MAINTENANCE:**

None

END OF TASK

10-276

10-55.2 REMOVE EXTENDED RANGE FUEL SYSTEM (ERFS II) REFUELING HOSE ASSEMBLY**10-55.2****INITIAL SETUP****Applicable Configurations:**With **82****Tools:**

Aircraft Mechanic's Tool Kit, NSN 5180-00-323-4692
 Blanking Plate, 234P4116-6
 Grounded Container, 2 Quart or Equivalent

Materials:

Cloths (E135)
 Gloves (E186)

Personnel Required:

Medium Helicopter Repairer (2)

Equipment Condition:

Battery Disconnected (Task 1-39)
 Electrical Power Off
 Hydraulic Power Off
 Helicopter Grounded (Task 1-29)
 Forward Left Landing Gear Access Panel Open (Task 2-2)

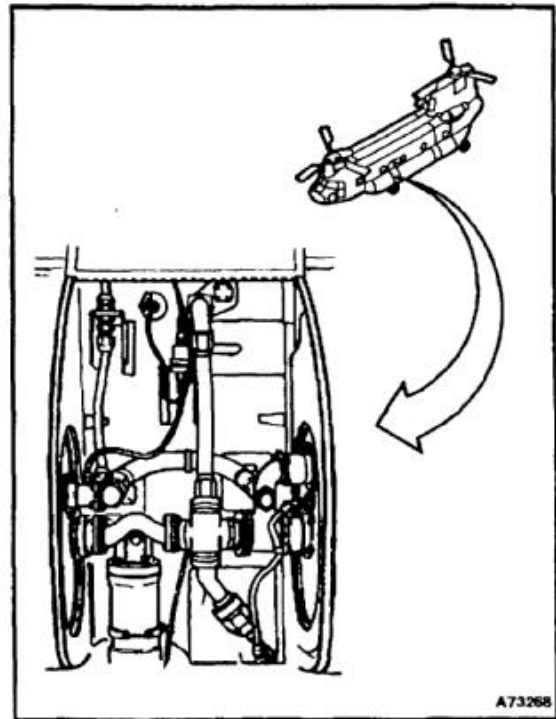
**General Safety Instructions:****WARNING**

All regulations and instructions for handling fuels shall be strictly observed.

10-55.2 REMOVE EXTENDED RANGE FUEL SYSTEM (ERFS II) REFUELING HOSE ASSEMBLY (Continued)

10-55.2

1. Remove nuts (1), washers (2), and bolts (3) from the flange at the bottom of hose (4).
2. Wearing gloves (E186), separate the hose (4) with gasket (5), from cross fitting (6). Allow fuel to drain into a container.
3. Disconnect electrical connector (7) from gate valve (8).
4. Request that a helper work in cabin to assist in removing four nuts (9) and washers (20) from coupling flange (10).
5. Have helper remove coupling (11) and spacer (17), with two packings (18), from aircraft fitting (12).
6. Supporting the gate valve (8), remove four bolts (13) and washers (14) from the top flange of hose (4).
7. Remove the valve (8) and hose (4), with gaskets (5, 15 and 16).
8. Position blanking plate (19) over gasket (5) on cross fitting (6).
9. Install four bolts (3), washers (2), and nuts (1).

FOLLOW-ON MAINTENANCE:

None

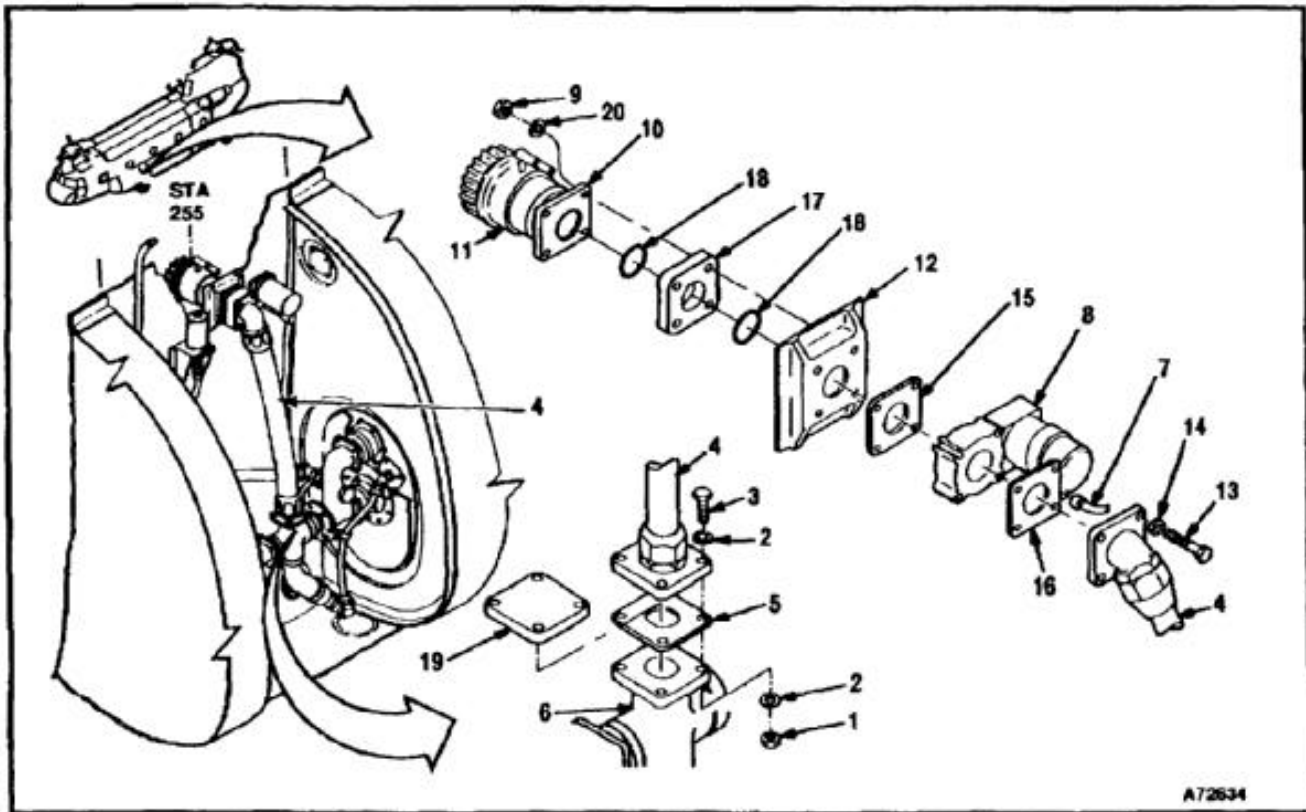

END OF TASK

10-55.3 INSTALL EXTENDED RANGE FUEL SYSTEM (ERFS II) REFUELING HOSE ASSEMBLY**10-55.3****INITIAL SETUP****Applicable Configurations:**With **82****Tools:**

Aircraft Mechanic's Tool Kit, NSN 51 80-00-323-4692

Materials:

None

Personnel Required:

Medium Helicopter Repairer (2)

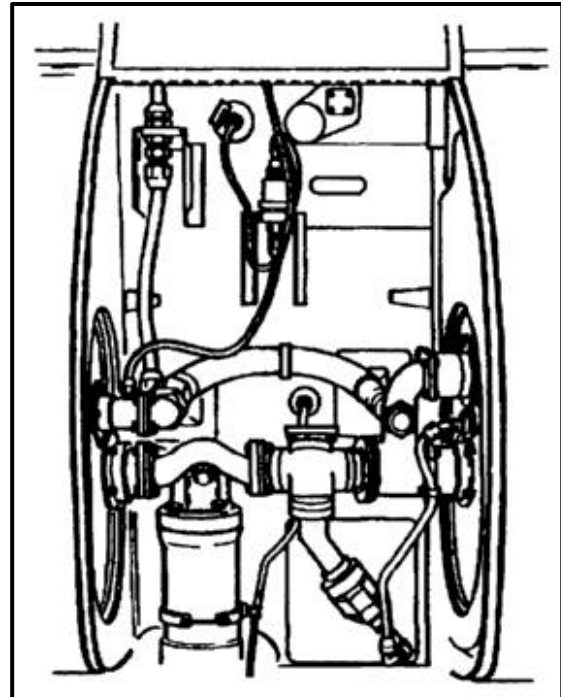

10-55.3 INSTALL EXTENDED RANGE FUEL SYSTEM (ERFS II) REFUELING HOSE ASSEMBLY (Continued)

10-55.3

1. Remove nuts (1) washers (2), and bolts (3).
2. Remove blanking plate (19), with gasket (5), from the flange of cross fitting (6).
3. Position the gate valve (8) with gasket (15) against airframe fitting (12).
4. Position the upper flange of hose (4) with gasket (16) against the valve (8).
5. Install four bolts (13) and washers (20) through the hose flange and the body of the valve (8).
6. Request that helper, working in the cabin, position packings (18), spacer (17) and flange (10) of coupling (11) over the four bolts and against the airframe fitting (12) and gasket (15).
7. Have helper install washers (20) and nuts (9).
8. Position the bottom flange of hose (4), with gasket (5) on the flange of cross fitting (6).
9. Install four bolts (3), washers (2), and nuts (1).
10. Install electrical connector (7) on gate valve (8).

FOLLOW-ON MAINTENANCE:

Close forward left landing gear access panel (Task 2-2).

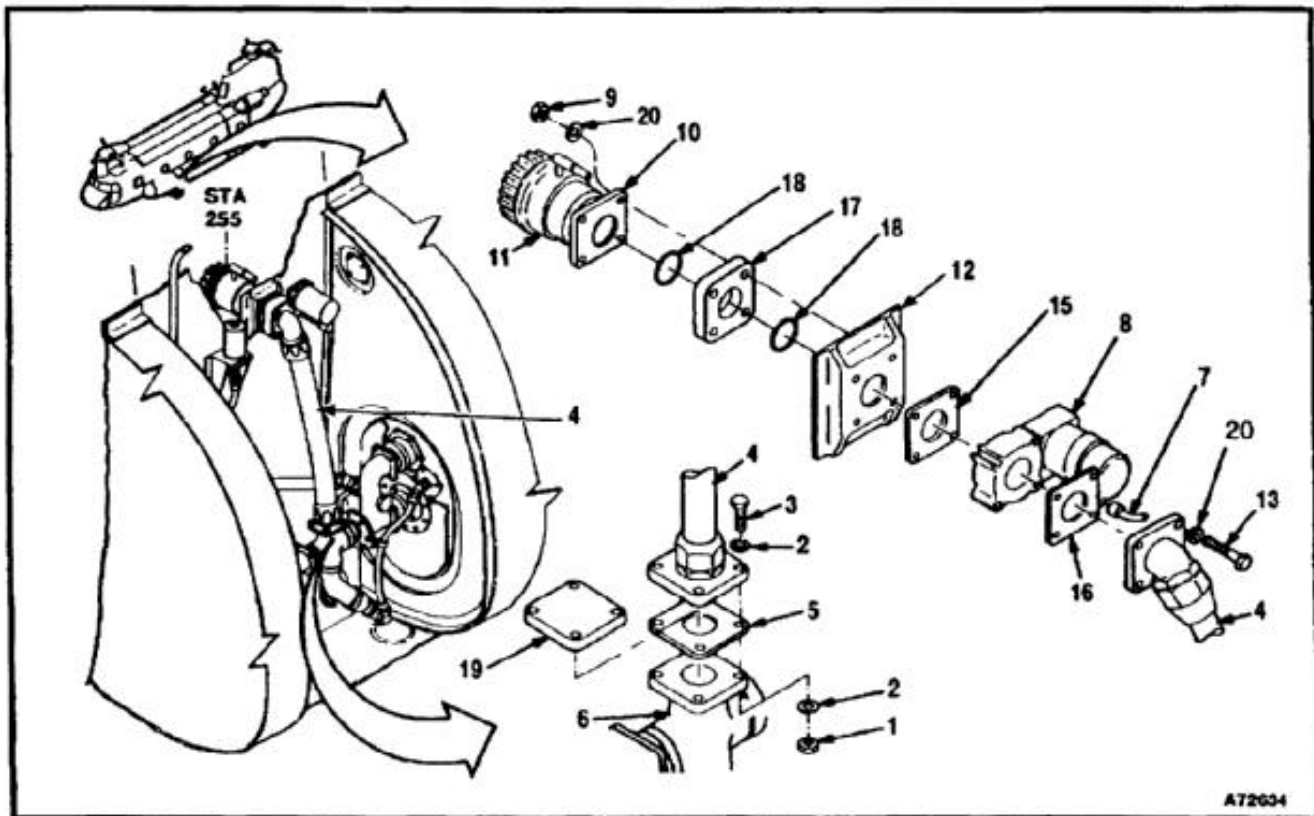

END OF TASK

10-280

INITIAL SETUP

Applicable Configurations:Without **82****Tools:**

Aircraft Mechanic's Tool Kit, NSN 51 80-00-323-4692

Materials:

Cloths (E135)
 Dry Cleaning Solvent (E162)
 Gloves (E186)
 Lockwire (E231)

Parts:

Packings
 Gaskets

Personnel Required:

Medium Helicopter Repairer
 Inspector

References:

TM 55-1520-240-23P

General Safety Instructions:**WARNING**

All regulations and instructions
 for handling fuels shall be strictly
 observed.

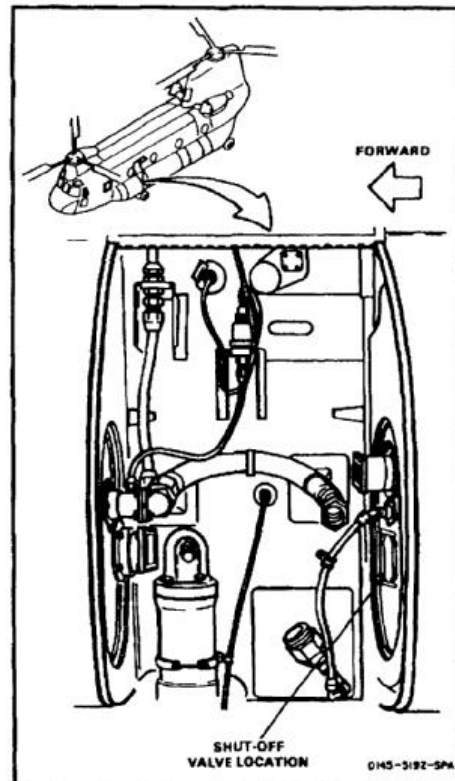

1. Position tube (1) on valve (2). Install four bolts (3) washers (4) and nuts (5).
2. Install packing (6) on breakaway fitting (7). Position fitting on valve (2). Install four bolts (8) and washers (9).

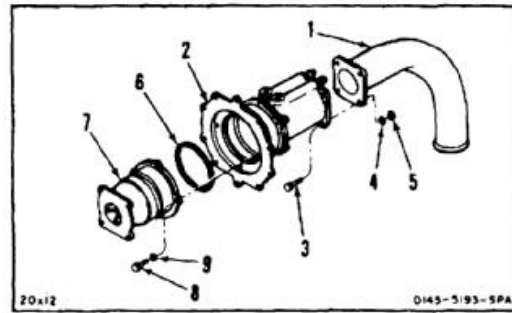

3. Install packing (10) on flange of valve (2).

WARNING

Dry cleaning solvent (E162) is flammable and toxic. It can irritate skin and cause burns. Use only in well-ventilated area, away from heat and open flame. In case of contact, immediately flush skin or eyes with water for at least **15 minutes**. Get medical attention for eyes.

4. Remove barrier material and tape from hole in tank (11). Clean tape residue from tank. Use dry cleaning solvent (E162) and cloths (E135). Wear goggles to protect eyes. Wear gloves (E186).
5. Pull two hoses (12) through hole in tank (11) to outside of tank. Maneuver valve (2) into position next to hole in tank (11). Connect two hoses (12) to valve.
6. Position valve (2) against face of tank. Install 10 bolts (13) and washers (14).

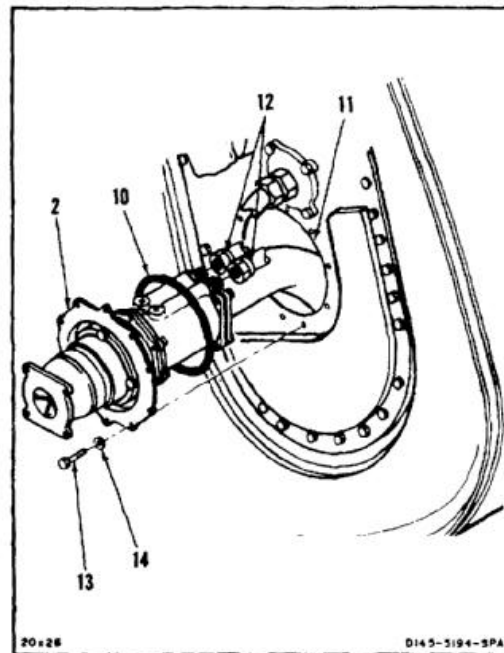

10-56 INSTALL MAIN TANK (NO. 1 SYSTEM) FUEL LEVEL SHUTOFF VALVE (Continued)

7. Install four packings (15) on elbow (16), tube (17), and manifold (18).

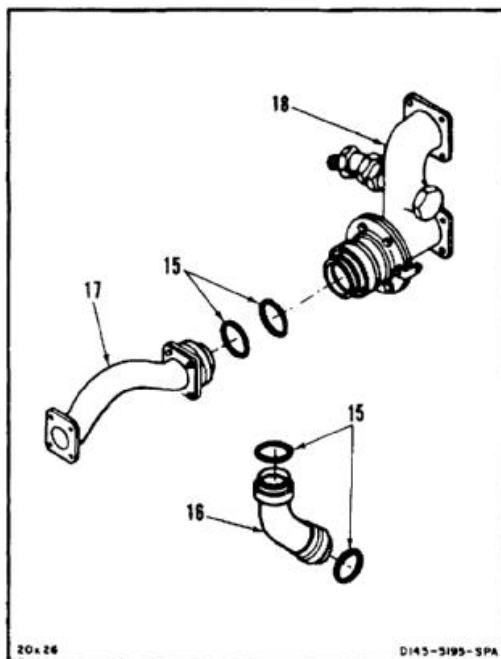

8. Remove plugs from four fittings (19). Position two gaskets (20 and 21).

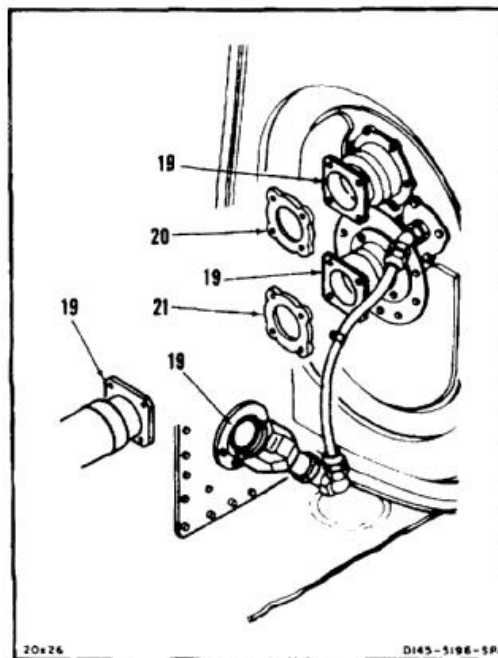

9. Position manifold (18). Install eight bolts (22), washers (23), and nuts (24).
10. Remove plug from hose (25). Install conical seal (25.1). Install hose on manifold (18).
11. Position hose clamp (26). Install bolt (27), two washers (28), and nut (29).

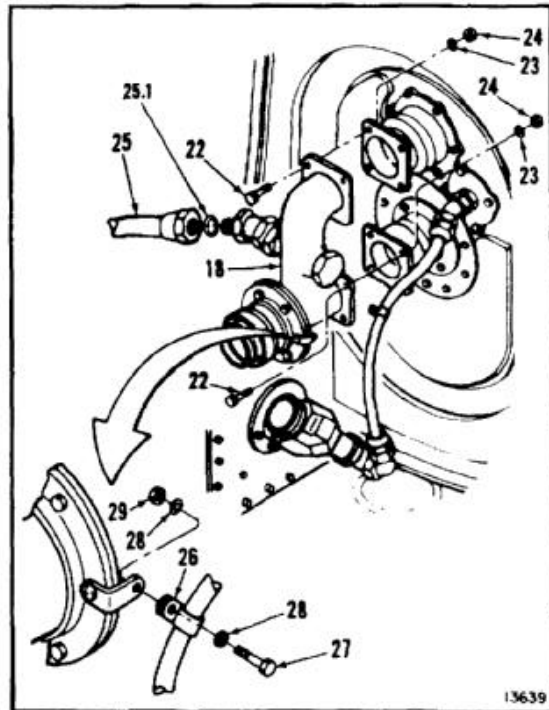

12. Position gasket (30).

NOTE

Tube (17) is not symmetrical. Make sure that the upper nut on the landing gear mount remains accessible when installing the tube.

13. Maneuver tube (17), tee (31), and elbow (16) into position on manifold (18) and fittings (19).
14. Install four bolts (32), washers (33), and nuts (34).



Do not use strap wrench or overtighten ring nuts, failure of the breakaway fittings may occur.

15. Hand tighten four ring nuts (35) and lockwire. Use lockwire (E231).

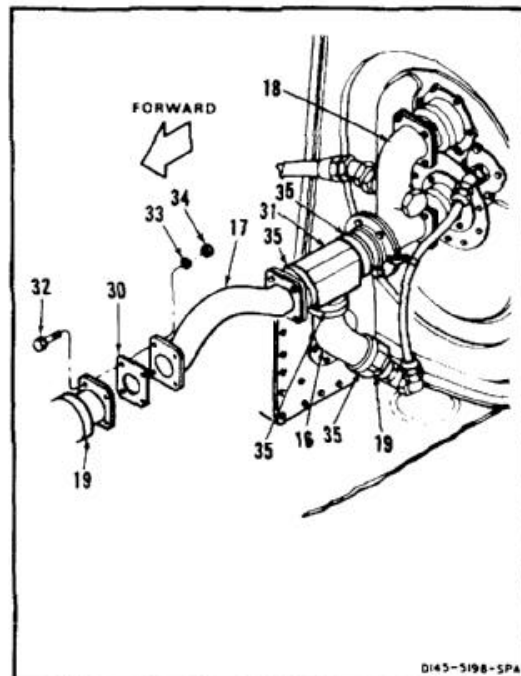

FOLLOW-ON MAINTENANCE:

- Perform test of pressure refueling system (Task 10-119).
- Refuel left side of helicopter (Task 1-51).
- Bleed fuel system (Task 10-121).
- Check for leaks (Task 10-4).
- Perform operational check of fuel system (TM 55-1520-240-T).
- Close and latch forward landing gear access panel (Task 2-2).

END OF TASK

INITIAL SETUP

Applicable Configurations:With **82****Tools:**

Aircraft Mechanic's Tool Kit, NSN 5180-00-323-4692

Materials:

Cloths (E135)
 Dry Cleaning Solvent (E162)
 Gloves (E186)
 Lockwire (E231)

Parts:

Packings
 Gaskets

Personnel Required:

Medium Helicopter Repairer
 Inspector

References:

TM 55-1520-240-23P

General Safety Instructions:**WARNING**

All regulations and instructions
 for handling fuels shall be strictly
 observed.

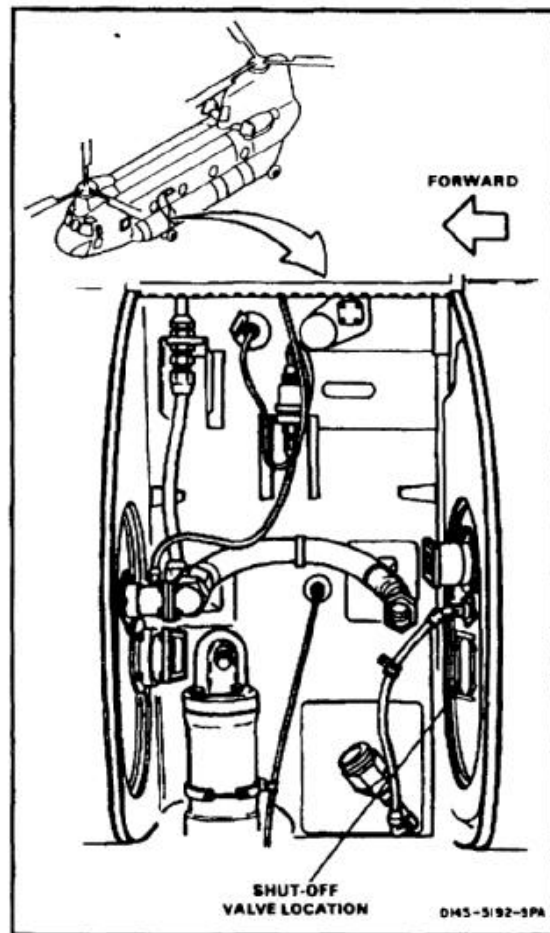

10-56.1 INSTALL MAIN TANK (NO. 1 SYSTEM) FUEL LEVEL SHUTOFF VALVE (Continued)

10-56.1

1. Position tube (1) on valve (2). Install four bolts (3), washers (4), and nuts (5).
2. Install packing (6) on breakaway filling (7). Position fitting on valve (2). Install four bolts (8) and washers (9).

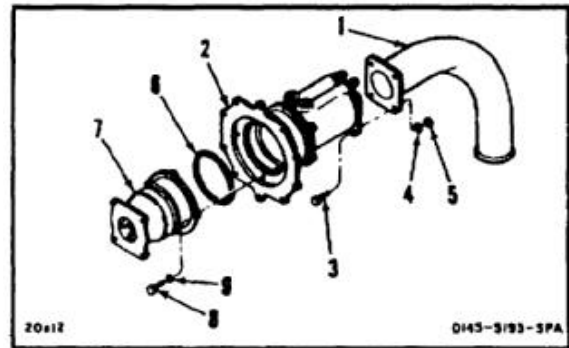

3. Install packing (10) on flange of valve (2).

WARNING

Dry cleaning solvent (E162) is flammable and toxic. It can irritate skin and cause burns. Use only in well-ventilated area, away from heat and open flame. In case of contact, immediately flush skin or eyes with water for at least **15 minutes**. Get medical attention for eyes.

4. Remove barrier material and tape from hole in tank (11). Clean tape residue from tank. Use dry cleaning solvent (E162) and cloths (E135). Wear goggles to protect eyes. Wear gloves (E186).
5. Pull two hoses (12) through hole in tank (11) to outside of tank. Maneuver valve (2) into position next to hole in tank (11). Connect two hoses (12) to valve.
6. Position valve (2) against face of tank. Install 10 bolts (13) and washers (14).

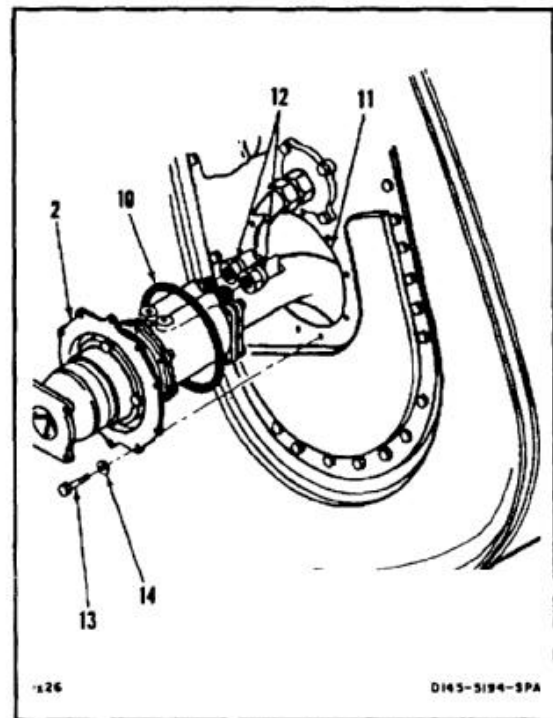

7. Install four packings (15) on elbow (16), tube (17), and manifold (18).

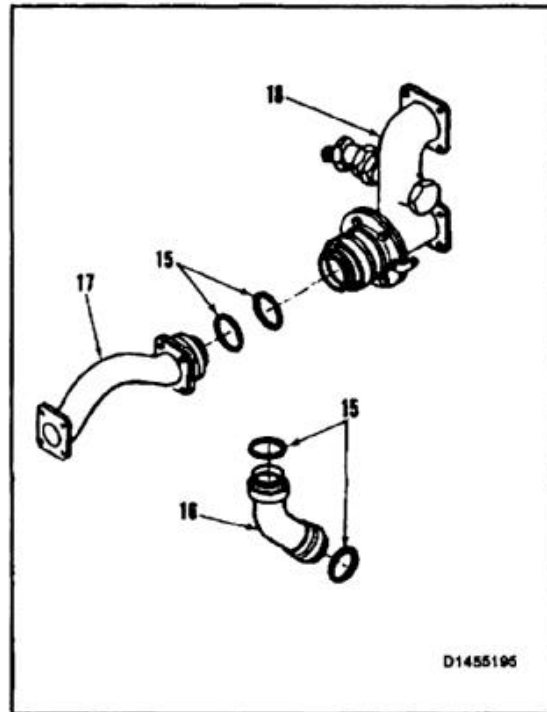

8. Remove plugs from four fittings (19). Position two gaskets (20 and 21).

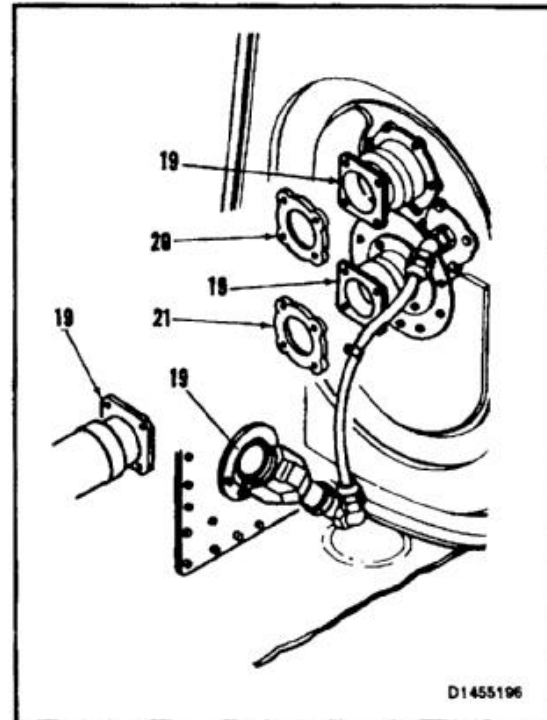

10-56.1 INSTALL MAIN TANK (NO. 1 SYSTEM) FUEL LEVEL SHUTOFF VALVE (Continued)

10-56.1

9. Position manifold (18). Install eight bolts (22), washers (23), and nuts (24).
10. Remove plug from hose (25). Install conical seal (25.1). Install hose on manifold (18).
11. Position hose clamp (26). Install bolt (27), two washers (28), and nut (29).

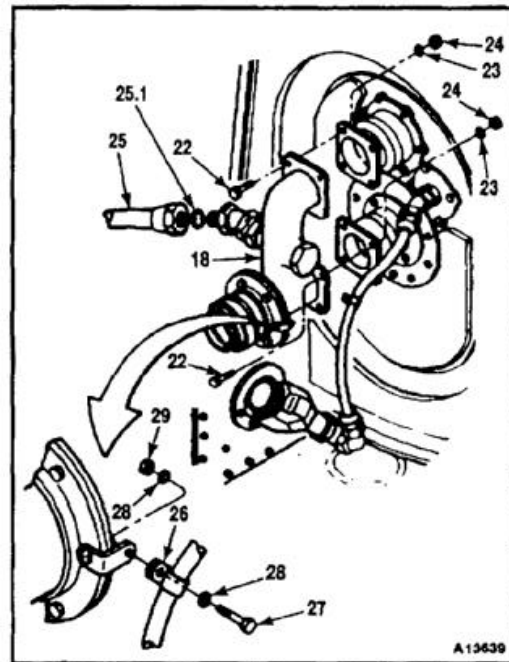

12. Position gasket (30).

NOTE

Tube (17) is not symmetrical. Make sure that the upper nut on the landing gear mount remains accessible when installing the tube.

13. Maneuver tube (17), fitting (31), and elbow (16) into position on manifold (18) and fittings (19).
14. Install four bolts (32), washers (33), and nuts (34).



Do not use strap wrench or over-tighten ring nuts. Failure of the breakaway fittings may occur.

15. Hand tighten four ring nuts (35) and lockwire. Use lockwire (E231).

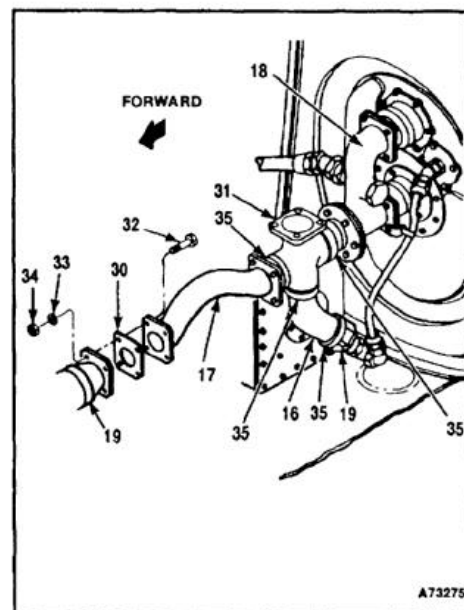

FOLLOW-ON MAINTENANCE:

- Install ERFS II refuel hose (Task 10-55.3).
- Perform test of pressure refueling system (Task 10-119).
- Refuel left side of helicopter (Task 1-51).
- Bleed fuel system (Task 10-121).
- Check for leaks (Task 10-4).
- Perform operational check of fuel system (TM 55-1520-240-T).
- Close and latch forward landing gear access panels (Task 2-2).

END OF TASK

10-57 MAIN TANK (NO. 2 SYSTEM) FUEL LEVEL SHUTOFF VALVE REMOVAL**10-57****INITIAL SETUP****Applicable Configurations:**

All

Tools:

Aircraft Mechanic's Tool Kit, NSN 5180-00-323-4692
 Wrench, Open End, 1-1/2 Inch
 Strap Wrench
 Grounded Container, 2 Quart or Equivalent

Materials:

Cloths (E135)
 Barrier Material (E80)
 Tape (E388)
 Gloves (E184.1)

Personnel Required:

Medium Helicopter Repairer

Equipment Condition:

Battery Disconnected (Task 1-39)
 Electrical Power Off
 Helicopter Grounded (Task 1-29)
 Forward Right Landing Gear Access Door Opened
 (Task 2-2)
 All Tanks On Right Side Of Helicopter Defueled and
 Both Crossover Valves Closed (Task 10-34 or
 10-35)
 Refueling Adapter Removed (Task 10-87)

General Safety Instructions:**WARNING**

All regulations and instructions
 for handling fuels shall be strictly
 observed.

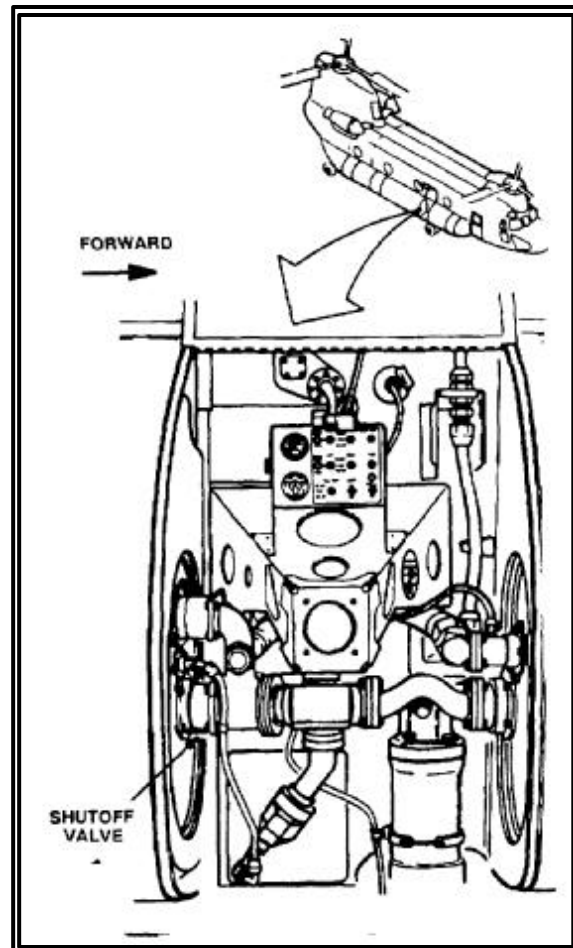

NOTE

Index numbers 1 through 6 not used.

1. Disconnect hose connector (9) from inboard fitting on manifold (10). Remove conical seal (8) from hose fitting. Plug the hose.
2. Remove lockwire (18) and loosen ring nut (19) at the bottom of elbow (17). Use a strap wrench.
3. Remove four bolts (16), nuts (14), and washers (15) from each end of tube (12).
4. Slide the fitting at the forward end of cross fitting (7) aft. Remove tube (12), with gaskets (11), from between the cross fitting and adapter (13). Use a grounded container to catch spilled fuel. Wear gloves (E184.1).

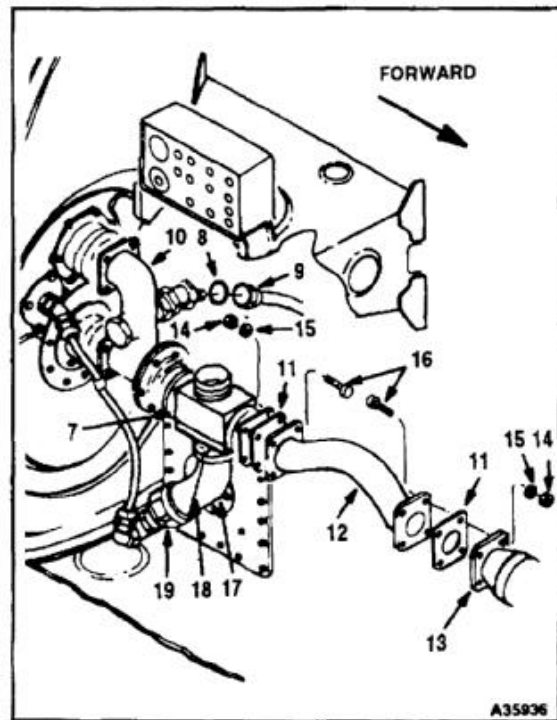

5. Remove four bolts (20), nuts (22), and washers (21) from each of the two flanges on manifold (10). Remove the clip of hose clamp (24) from the lower flange.
6. Carefully lift the manifold (10), with gaskets (23), cross fitting (7), and elbow (17) as an assembly up and back from fitting (25) and forward fuel tank fittings (19). Use a grounded container to catch spilled fuel. Wear gloves (E184.1).
7. Plug all component openings.

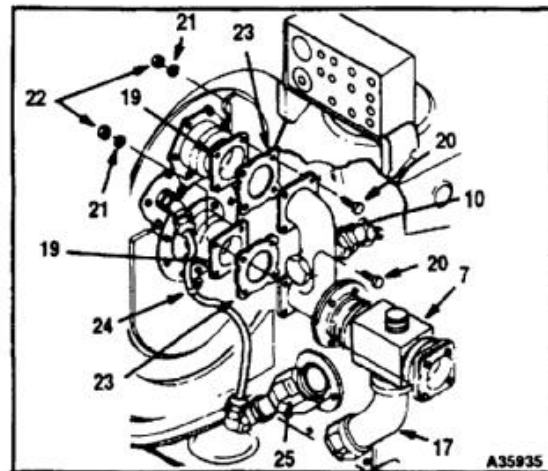

10-57 MAIN TANK (NO. 2 SYSTEM) FUEL LEVEL SHUTOFF VALVE REMOVAL (Continued)**10-57**

8. Remove 10 bolts (26) and washers (27).
9. Withdraw fuel valve (28) from tank (29) for access to two hoses (30). Disconnect the hoses from the valve.
10. Maneuver fuel valve (28) from tank (29). Cover the opening in the tank with barrier material (E80) and tape (E388).
11. Remove packing (31) from the mounting flange of fuel valve (28).

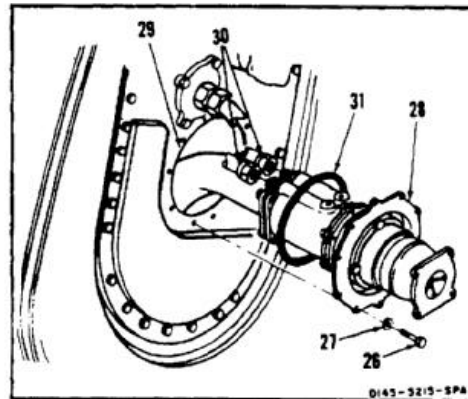

12. Remove four bolts (32) and washers (33). Remove fitting (34), with packing (35), from valve (28).
13. Remove four bolts (36), washers (37), and nuts (38). Remove tube (39).
14. Clean up spilled fuel. Use cloths (E135). Wear gloves (E184.1).

FOLLOW-ON MAINTENANCE:

None

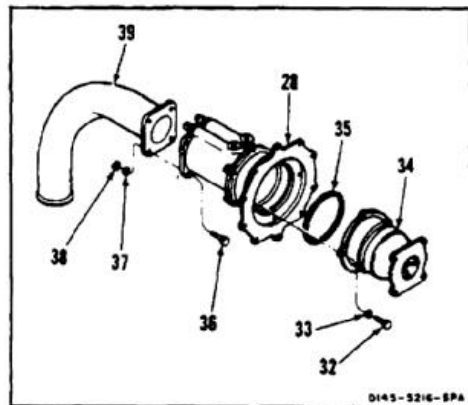

END OF TASK

INITIAL SETUP

Applicable Configurations:

All

Tools:

Aircraft Mechanic's Tool Kit, NSN 5180-00-323-4692
Wrench, Open End, 1-1/2 Inch

Materials:

Gloves (E184.1)
Dry Cleaning Solvent (E162)
Cloths (E120)
Lockwire (E231)

Parts:

Packings
Gaskets

Personnel Required:

Medium Helicopter Repairer
Inspector

References:

TM 55-1520-240-23P

General Safety Instructions:**WARNING**

All regulations and instructions
for handling fuels shall be strictly
observed.

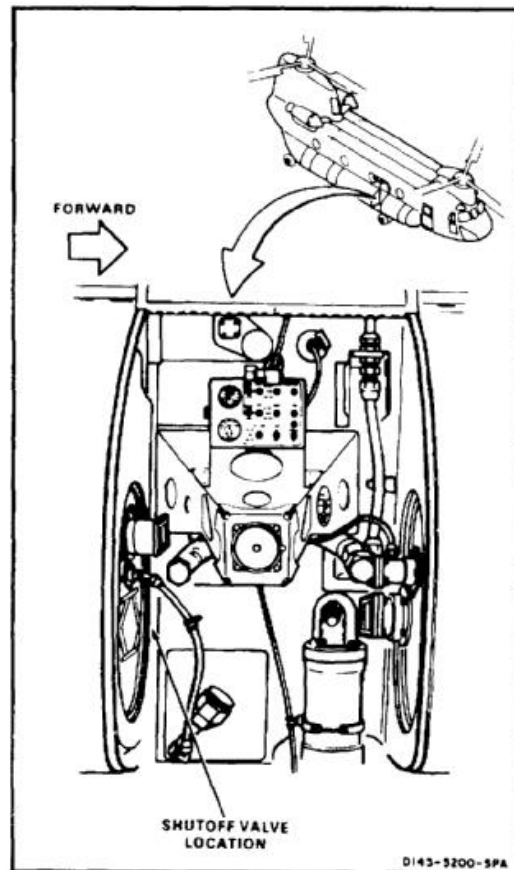

1. Position tube (1) against valve (2). Install four bolts (3), washers (4), and nuts (5).
2. Install packing (6) on fitting (7). Position fitting against valve (2). Install four bolts (8) and washers (9).

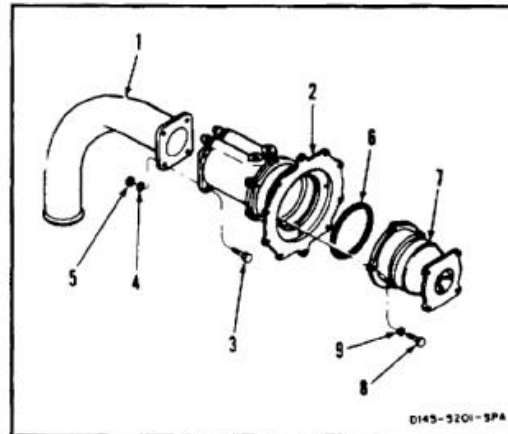

3. Install packing (10) on mounting flange of valve (2).

WARNING

Dry cleaning solvent (E162) is flammable and toxic. It can irritate skin and cause burns. Use only in well-ventilated area, away from heat and open flame. In case of contact, immediately flush skin or eyes with water for at least **15 minutes**. Get medical attention for eyes.

4. Remove barrier material and tape from the opening in tank (11). Clean tape residue from tank with dry cleaning solvent (E162) and cloths (E120). Wear goggles to protect eyes. Wear gloves (E184.1).
5. Pull the ends of hoses (12) through the opening to the outside of tank (11). Maneuver valve (2) into position next to the tank opening. Connect the hoses to the valve. Remove tags.
6. Position valve (2) against the face of tank (11). Install 10 bolts (13) and washers (14).

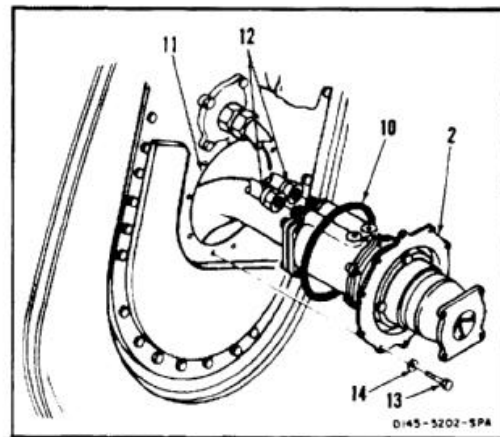

7. Remove plugs from the assembly of manifold (20), cross fitting (21), and elbow (22). Align the assembly, with two gaskets (18), with the two tank fittings and lower fitting (23).
8. Install four bolts (17), washers (16), and nuts (15) at the top flange of manifold (20).
9. Position the clip of hose clamp (19) against the lower flange of manifold (20) at the lower outboard hole. Install four bolts (17), washers (16), and nuts (15).



Do not use a strap wrench or overtighten the ring nut. Failure may occur.

10. Hand tighten the lower ring nut on elbow (22) on fitting (23). Lockwire the lower ring nut to the upper ring nut. Use lockwire (E231).

NOTE

When connecting fuel hoses to the forward access panel, do not allow the fittings to turn. If they turn, the fittings can fail and cause fuel blockage.

11. Remove the plug from hose (25). Install conical seal (24) in the hose fitting. While holding the manifold fitting with a wrench, connect the hose to the inboard fitting of manifold (20).

NOTE

Tube (30) is not symmetrical. Make sure the upper nut on the landing gear mount remains accessible when installing the tube.

Aft gasket (29) has a larger center hole than the forward gasket.

12. Position gaskets (29) and tube (30) between forward tank adapter (31) and cross fitting (21). Slide the forward fitting on the cross fitting forward to hold the tube and gaskets in place.
13. Install four bolts (28), washers (27) and nuts (26) at each end of the tube. Make sure the heads of the bolts face each other.

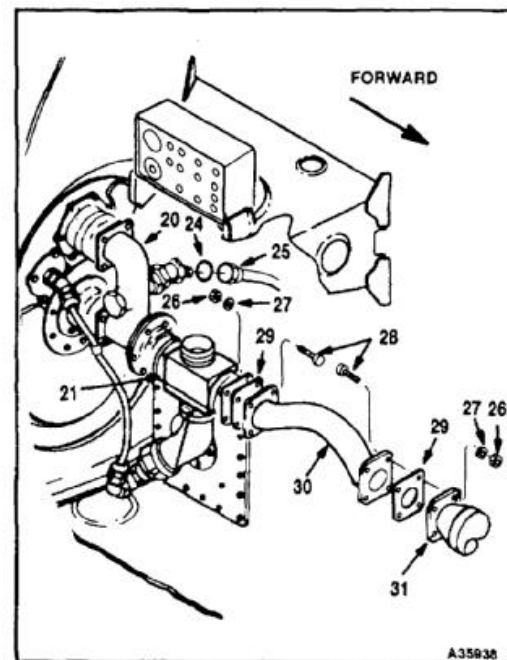
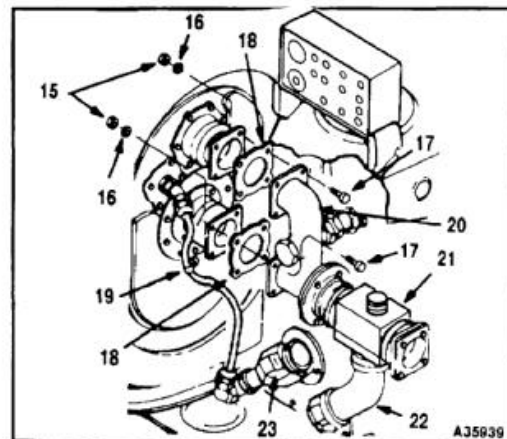

INSPECT***FOLLOW-ON MAINTENANCE:***

- Install refueling adapter (Task 10-88).
- Perform test of pressure refueling system (Task 10-119).
- Refuel right side of helicopter (Task 1-51).
- Bleed fuel system (Task 10-121).
- Check for leaks (Task 10-4).
- Perform operational check of fuel system (TM 55-1520-240-T).
- Close and latch the forward landing gear access panel (Task 2-2).

END OF TASK

10-59 REMOVE FUEL LEVEL CONTROL VALVE AND MOUNTING BRACKET FROM MAIN FUEL TANKS

INITIAL SETUP

Applicable Configurations:

All

Tools:

Aircraft Mechanic's Tool Kit, NSN 5180-00-323-4692

Materials:

- Barrier Material (E80)
- Paper Tags (E264)
- Tape (E388)

Personnel Required:

Medium Helicopter Repairer

Equipment Condition:

- Battery Disconnected (Task 1-39)
- Electrical Power Off
- Helicopter Grounded (Task 1-29)
- Aft Access Door Removed for Main Fuel Tank (Task 10-53)

General Safety Instructions:

WARNING

All regulations and instructions for handling fuels shall be strictly observed.

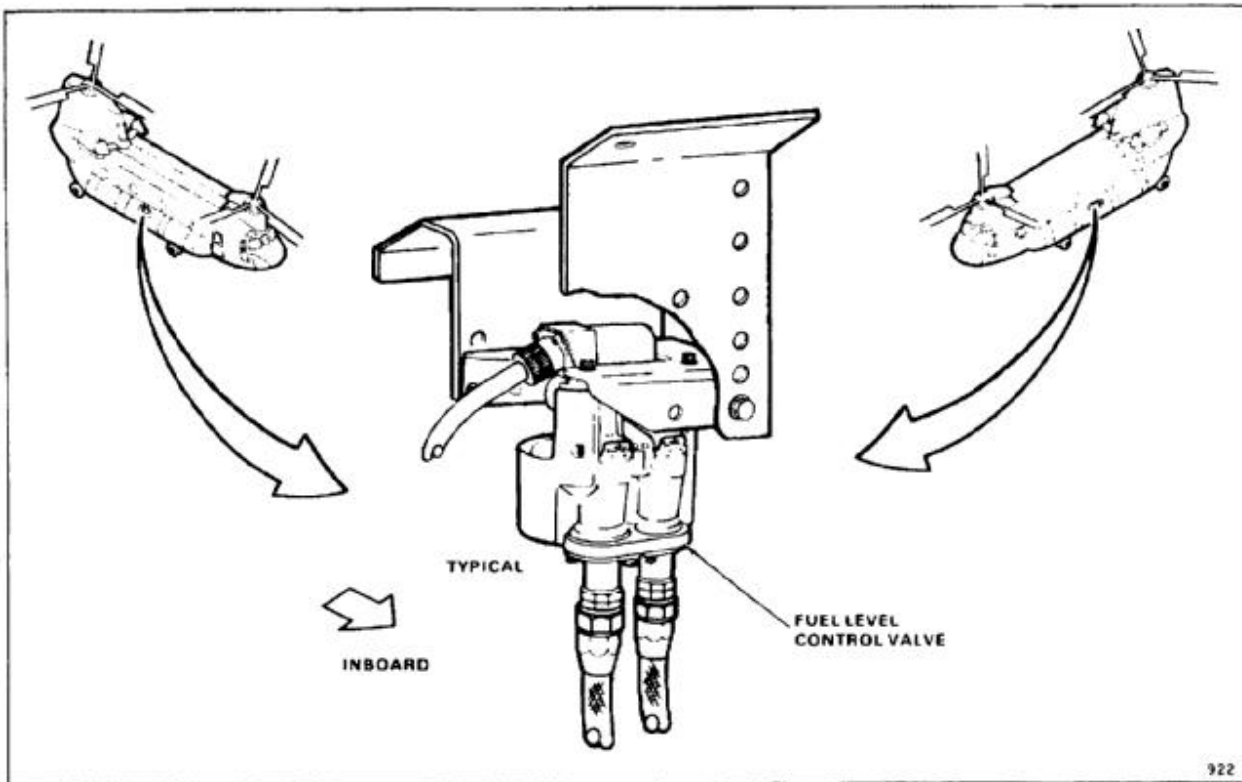

10-59 REMOVE FUEL LEVEL CONTROL VALVE AND MOUNTING BRACKET FROM MAIN FUEL TANKS (Continued)

10-59



Do not puncture or scratch lining of fuel tank. If lining is broken, fuel penetrates and activates self-sealing layers. Activated layers swell and trap fuel. Activated green spongy material also contaminates fuel system. This makes it necessary to replace fuel tank and flush fuel system.

NOTE

Procedure is same to remove fuel level control valve and mounting bracket from either main fuel tank. Removal of valve and mounting bracket for No. 1 (left) tank is shown here.

REMOVE CONTROL VALVE

1. Disconnect electrical cable (1).
2. Tag and disconnect hoses (2 and 3).
3. Remove four bolts (4) and washers (5).
4. Remove valve (6).

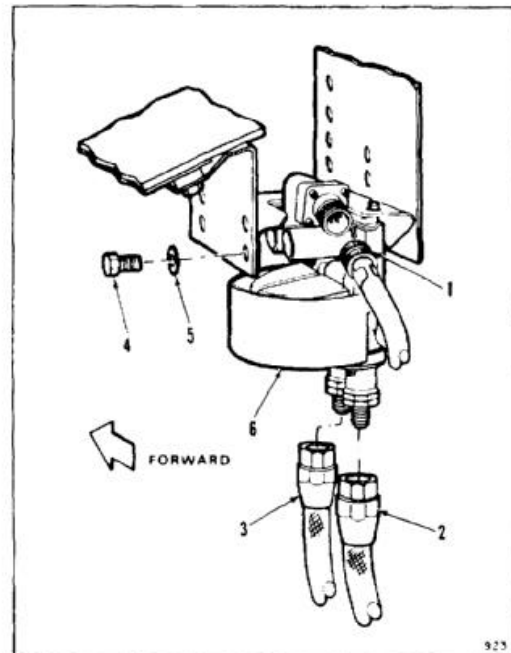

REMOVE MOUNTING BRACKET**NOTE**

Three different types of mounting bracket installation are used on the helicopter. Each requires a different attachment to the inside of the fuel cell.

5. For fuel cells 414PS400-8, remove three bolts (7) and washers (8). Remove brackets (9).

For fuel cell 145P4057-1, remove three bolts (10) and three washers (11). Remove bracket (12) and three washers (13).

For fuel cell 145P4057-2, remove three bolts (14) and washers (15). Remove bracket (16) and three bushings (17).

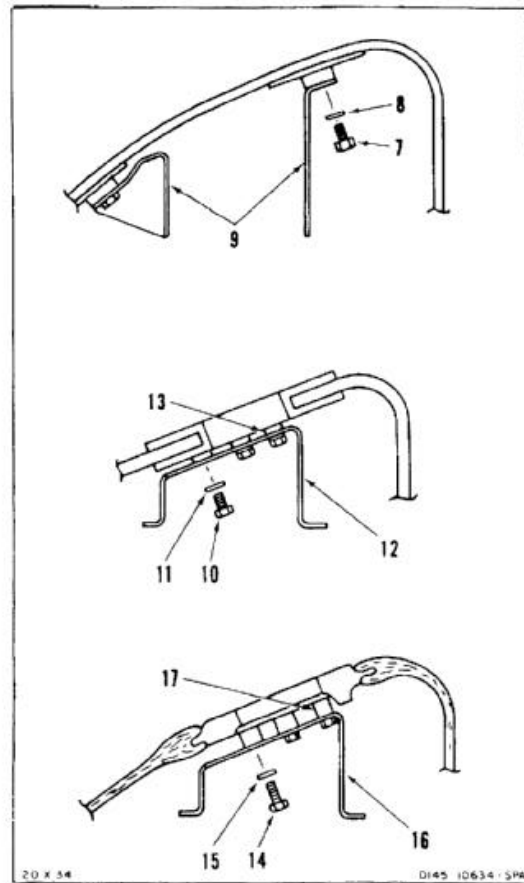

6. Cover access hole (18) in tank. Use barrier material (E80) and tape (E388).

FOLLOW-ON MAINTENANCE:

None

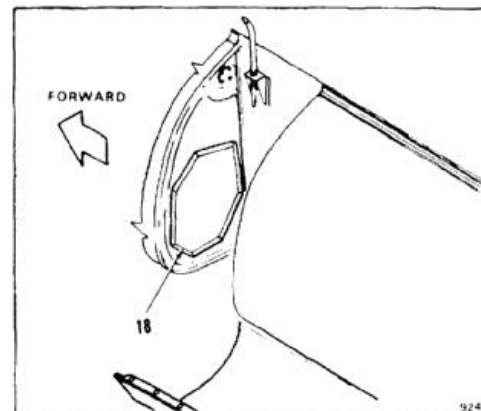

END OF TASK

10-300

10-60 INSTALL FUEL LEVEL CONTROL VALVE AND MOUNTING BRACKET IN MAIN FUEL TANKS

10-60

INITIAL SETUP

Applicable Configurations:

All

Tools:

Aircraft Mechanic's Tool Kit, NSN 5180-00-323-4692

Materials:

- Dry Cleaning Solvent (E162)
- Cloths (E135)
- Gloves (E186)

Personnel Required:

- Medium Helicopter Repairer
- Inspector

References:

TM 55-1520-240-23P

General Safety Instructions:

WARNING

All regulations and instructions for handling fuels shall be strictly observed.

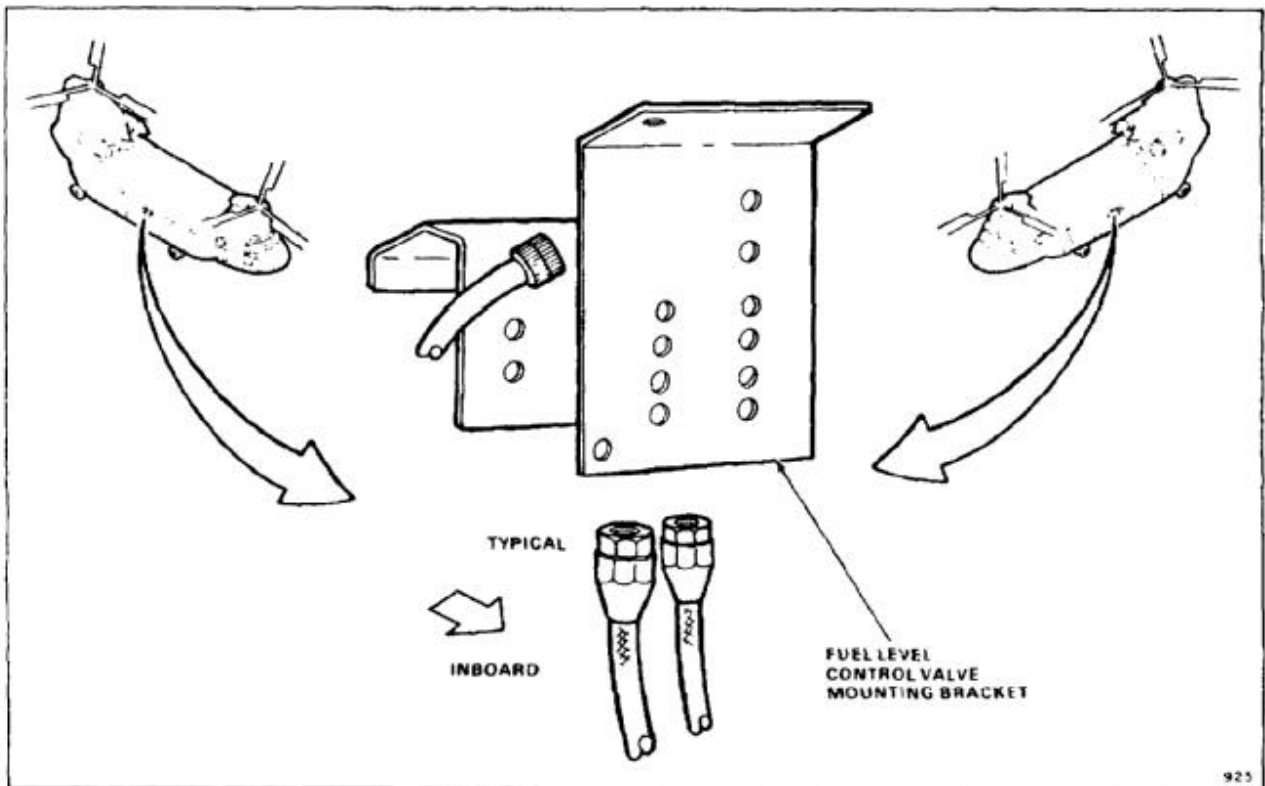

WARNING

Dry cleaning solvent (E162) is flammable and toxic. It can irritate skin and cause burns. Use only in well-ventilated area, away from heat and open flame. In case of contact, immediately flush skin or eyes with water for at least **15 minutes**. Get medical attention for eyes.

CAUTION

Do not use main tank fuel level control valves in auxiliary tanks or auxiliary tank valves in main tanks. Fuel system will not operate properly unless correct valves are used in correct tanks.

NOTE

Procedure is same to install fuel level control valve and mounting bracket in either main fuel tank. Installation of valve and bracket for No. 1 (left) tank is shown here.

1. Remove barrier material and tape from access hole (1) in tank. Remove tape residue from tank. Use dry cleaning solvent (E162) and cloths (E135). Wear goggles to protect eyes. Wear gloves (E186).

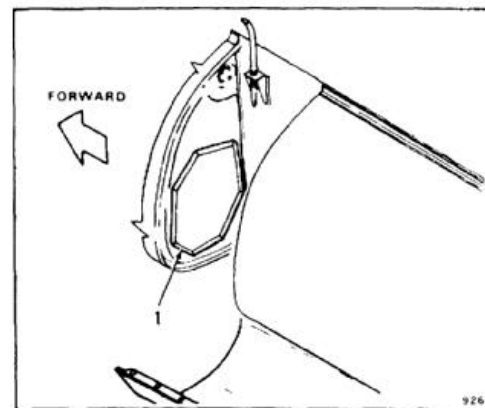

10-60 INSTALL FUEL LEVEL CONTROL VALVE AND MOUNTING BRACKET IN MAIN FUEL TANKS (Continued)

10-60

CAUTION

Do not puncture or scratch lining of fuel tank. If lining is broken, fuel penetrates and activates self-sealing layers. Activated layers swell and trap fuel. Activated green spongy material also contaminates fuel system. This makes it necessary to replace fuel tank and flush system.

INSTALL MOUNTING BRACKET
NOTE

Three different types of mounting bracket installation are used on the helicopter. Each requires a different attachment to the inside of the fuel cell.

2. For fuel cell 414PS400-8, position two brackets (2). Install three bolts (3) and washers (4). Do not tighten bolts at this time.

For fuel cell 145P4057-1, position three thick washers (5) and bracket (6). Install three bolts (7) and thin washers (8).

For fuel cell 145P4057-2, position three bushings (9) and bracket (10). Install three bolts (11) and washers (12).

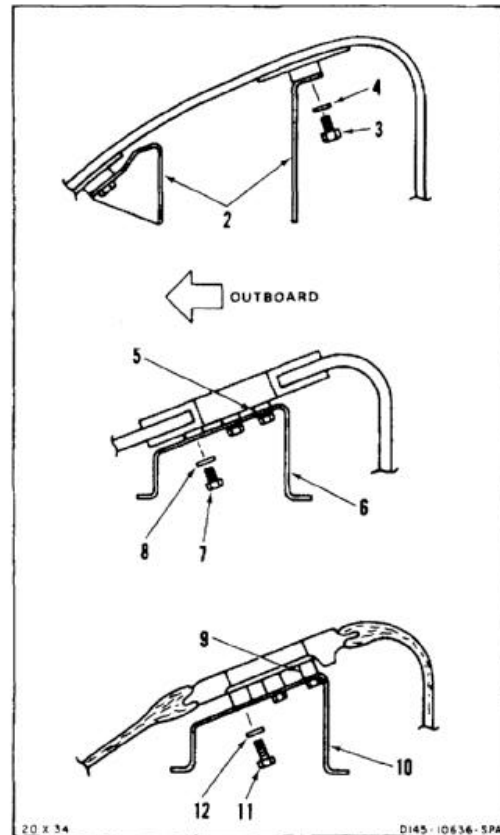

INSTALL CONTROL VALVE

3. Position valve (13) on bracket (2, 6 or 10).
4. Install four washers (14) and bolts (15) in bottom set of bracket mounting holes.
5. On fuel cell 414PS400-8, tighten three bolts (3).
6. Connect two hoses (16 and 17) to valve (13). Remove tags.
7. Connect electrical cable (18).

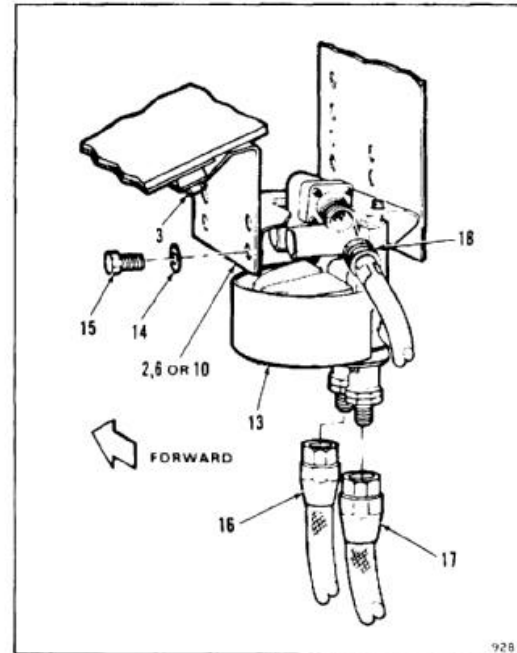
INSPECT**FOLLOW-ON MAINTENANCE:**

- Perform vent system pressure test (Task 10-117).
- Install aft access door (Task 10-54).
- Test main fuel tank (Task 10-22).
- Perform vent system flow test on affected tank (Task 10-118).
- Perform test of pressure refueling system (Task 10-119) and fuel feed system (Task 10-120).
- Refuel helicopter (Task 1-51).
- Bleed fuel system (Task 10-121).
- Perform operational check of appropriate fuel system (TM 55-1520-240-T).
- Inspect for leaks (Task 10-4).

END OF TASK

10-304

10-60.1 REMOVE FUEL LEVEL CONTROL VALVE AND MOUNTING BRACKET FROM AUXILIARY FUEL TANKS 10-60.1

INITIAL SETUP

Applicable Configurations:

All

Tools:

Aircraft Mechanic's Tool Kit, NSN 5180-00-323-4692

Materials:

- Barrier Material (E80)
- Paper Tags (E264)
- Tape (E388)

Personnel Required:

Medium Helicopter Repairer

Equipment Condition:

- Battery Disconnected (Task 1-39)
- Electrical Power Off
- Helicopter Grounded (Task 1-29)
- Forward Access Door Removed for Forward Fuel Tank (Task 10-69)
- Forward Access Door Removed for Aft Fuel Tank (Task 10-79)

General Safety Instructions:

WARNING

All regulations and instructions for handling fuels, shall be strictly observed.

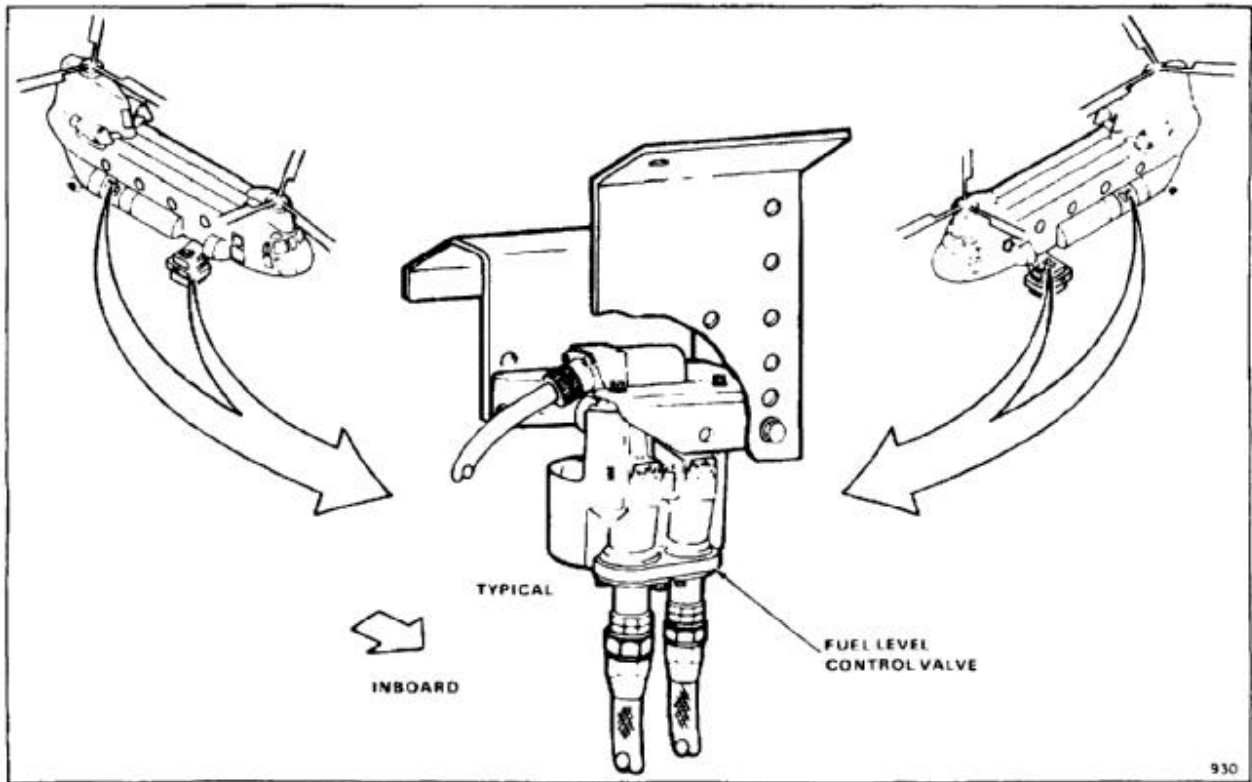

10-60.1 REMOVE FUEL LEVEL CONTROL VALVE AND MOUNTING BRACKET FROM AUXILIARY FUEL TANKS (Continued) 10-60.1

Do not puncture or scratch lining of fuel tank. If lining is broken, fuel penetrates and activates self-sealing layers. Activated layers swell and trap fuel. Activated green spongy material also contaminates fuel system. This makes it necessary to replace fuel tank and flush fuel system.

NOTE

Procedure is same to remove fuel level control valve and mounting bracket from any auxiliary fuel tank. Removal of valve and mounting bracket for No. 1 (left) aft tank is shown here.

REMOVE CONTROL VALVE

1. Disconnect electrical cable (1).
2. Tag and disconnect hoses (2 and 3).
3. Remove four bolts (4) and washers (5).
4. Remove valve (6).

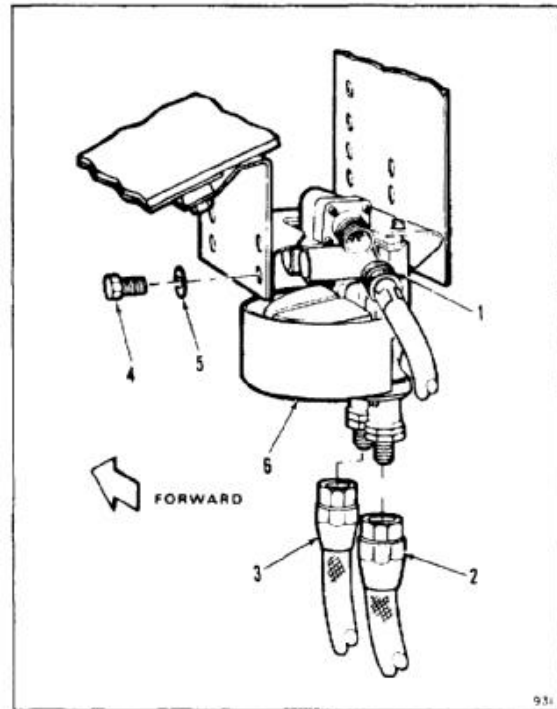

10-60.1 REMOVE FUEL LEVEL CONTROL VALVE AND MOUNTING BRACKET FROM AUXILIARY FUEL TANKS (Continued) 10-60.1
REMOVE MOUNTING BRACKET
NOTE

Three different types of mounting bracket installation are used on the helicopter. Each requires a different attachment to the inside of the fuel cell.

5. For fuel cells 414PS401-8, remove three bolts (7) and washers (8). Remove brackets (9).

For fuel cell 145P4056-1, remove three bolts (10) and three washers (11). Remove bracket (12) and three washers (13).

For fuel cell 145P4056-2, remove three bolts (14) and washers (15). Remove bracket (16) and three bushings (17).

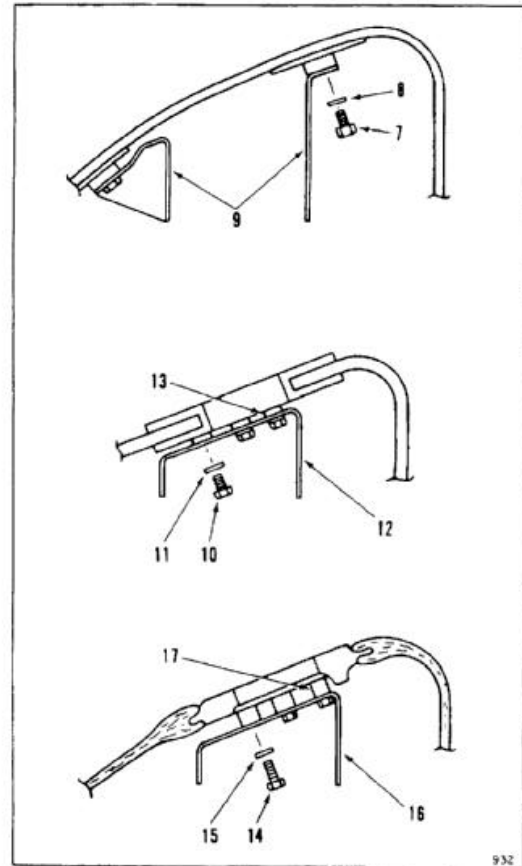

6. Cover access hole (18) in tank. Use barrier material (E80) and tape (E388).

FOLLOW-ON MAINTENANCE:

None

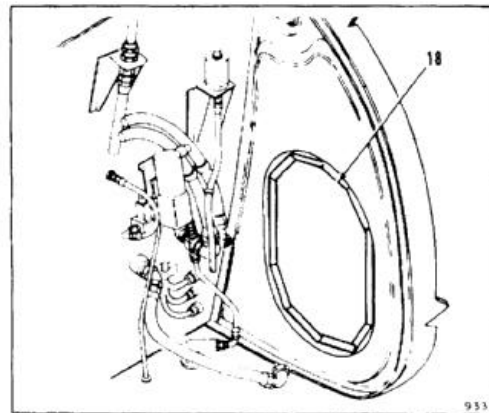

END OF TASK

10-60.2 INSTALL FUEL LEVEL CONTROL VALVE AND MOUNTING BRACKET IN AUXILIARY FUEL TANKS

INITIAL SETUP

Applicable Configurations:

All

Tools:

Aircraft Mechanic's Tool Kit, NSN 5180-00-323-4692

Materials:

- Dry Cleaning Solvent (E162)
- Cloths (E135)
- Gloves (E186)

Personnel Required:

- Medium Helicopter Repairer
- Inspector

References:

TM 55-1520-240-23P

General Safety Instructions:

WARNING

All regulations and instructions for handling fuels shall be strictly observed.

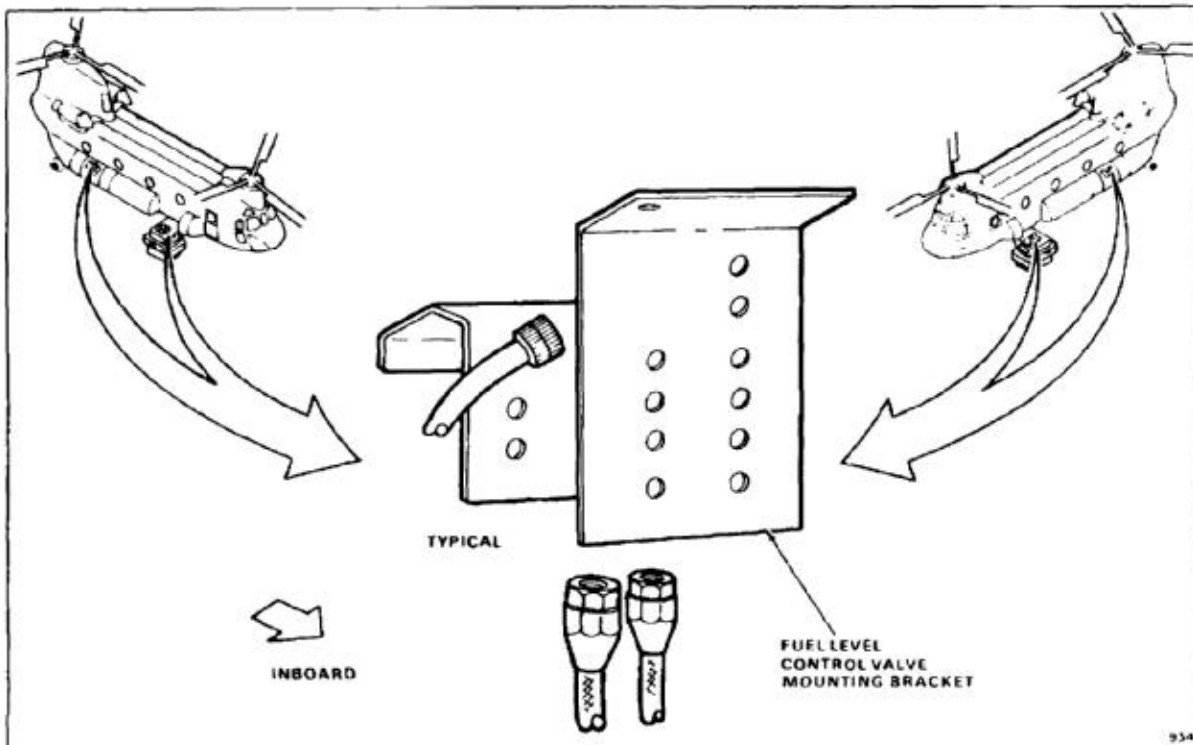

10-60.2 INSTALL FUEL LEVEL CONTROL VALVE AND MOUNTING BRACKET IN AUXILIARY FUEL TANKS (Continued)

10-60.2

WARNING

Dry cleaning solvent (E162) is flammable and toxic. It can irritate skin and cause burns. Use only in well-ventilated area, away from heat and open flame. In case of contact, immediately flush skin or eyes with water for at least **15 minutes**. Get medical attention for eyes.

CAUTION

Do not use main tank fuel level control valves in auxiliary tanks or auxiliary tank valves in main tanks. Fuel system will not operate properly unless correct valves are used in correct tanks.

NOTE

Procedure is same to install fuel level control valve and mounting bracket in any auxiliary fuel tank. Installation of valve and bracket for No. 1 (left) aft tank is shown here.

1. Remove barrier material and tape from access hole in tank (1). Remove tape residue from tank. Use dry cleaning solvent (E162) and cloths (E135). Wear goggles to protect eyes. Wear gloves (E186).

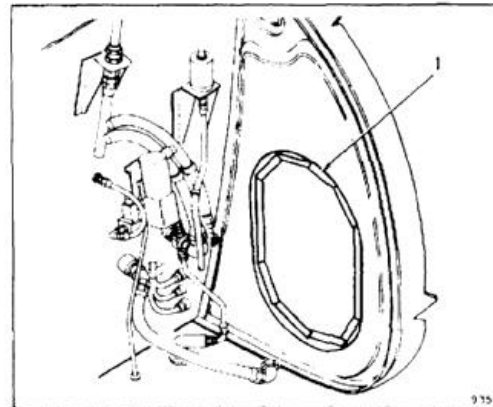

CAUTION

Do not puncture or scratch lining of fuel tank. If lining is broken, fuel penetrates and activates self-sealing layers. Activated layers swell and trap fuel. Activated green spongy material also contaminates fuel system. This makes it necessary to replace fuel tank and flush fuel system.

INSTALL MOUNTING BRACKET**NOTE**

Three different types of mounting bracket installation are used on the helicopter. Each requires a different attachment to the inside of the fuel cell.

2. For fuel cell 414PS401-8, position two brackets (2). Install three bolts (3) and washers (4). Do not tighten bolts at this time.

For fuel cell 145P4056-1, position three thick washers (5) and bracket (6). Install three bolts (7) and thin washers (8).

For fuel cell 145P4056-2, position three bushings (9) and bracket (10). Install three bolts (11) and washers (12).

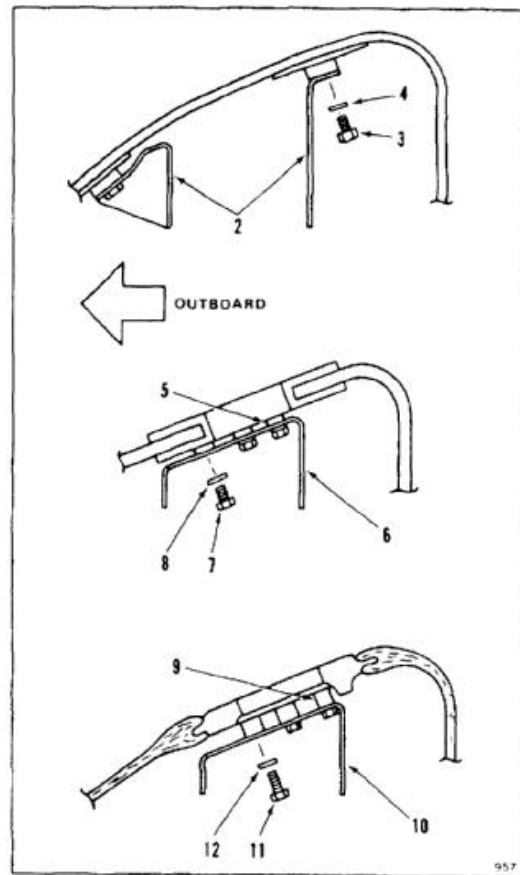

10-60.2 INSTALL FUEL LEVEL CONTROL VALVE AND MOUNTING BRACKET IN AUXILIARY FUEL TANKS (Continued)

10-60.2

INSTALL CONTROL VALVE

3. Position valve (13) on bracket (2, 6 or 10).
4. Install four washers (14) and bolts (15) in lowest hole locations.
5. On fuel cell 414PS401-8, tighten three bolts (3).
6. Connect two hoses (16 and 17) to valve (13). Remove tags.
7. Connect electrical cable (18).

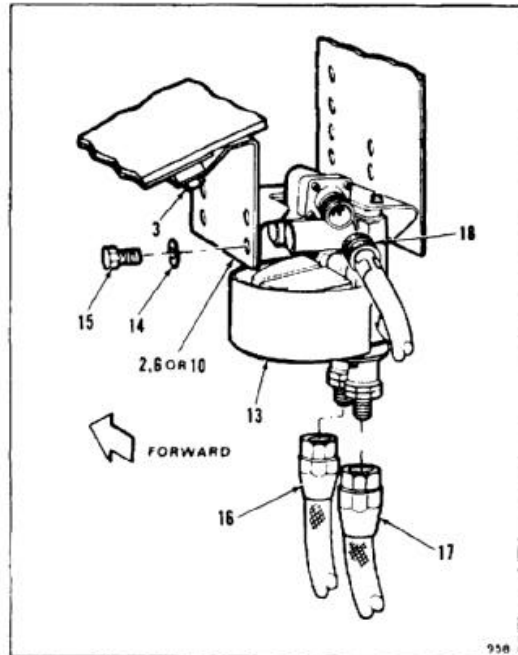
INSPECT**FOLLOW-ON MAINTENANCE:**

Perform vent system pressure test (Task 10-117).

For forward fuel tank:

- Install forward access door (Task 10-26).
- Install forward fuel tank (Task 10-70).
- Test forward fuel tank (Task 10-27).

For aft fuel tank:

- Install forward access door (Task 10-80).
- Install fuel level shutoff valve (Task 10-82).
- Test aft fuel tank (Task 10-32).
- Perform vent system flow test on affected tank (Task 10-118).
- Perform test of pressure refueling system (Task 10-119) and fuel feed system (Task 10-120).
- Refuel helicopter (Task 1-51).
- Bleed fuel system (Task 10-121).
- Perform operational check of appropriate fuel system (TM 55-1520-240-T).
- Inspect for leaks (Task 10-4).

END OF TASK

INITIAL SETUP

Applicable Configurations:

All

Tools:

Aircraft Mechanic's Tool Kit, NSN 5180-00-323-4692

Materials:Barrier Material (E80)
Tape (E388)**Personnel Required:**

Medium Helicopter Repairer

Equipment Condition:Battery Disconnected (Task 1-39)
Electrical Power Off
Helicopter Grounded (Task 1-29)
Main Fuel Tank Defueled (Task 10-34 or 10-35)
Aft Intertank Pod Lowered (Task 2-185)
Main Fuel Tank Aft Access Door Removed (Task 10-53)**General Safety Instructions:****WARNING**

All regulations and instructions for handling fuels shall be strictly observed.

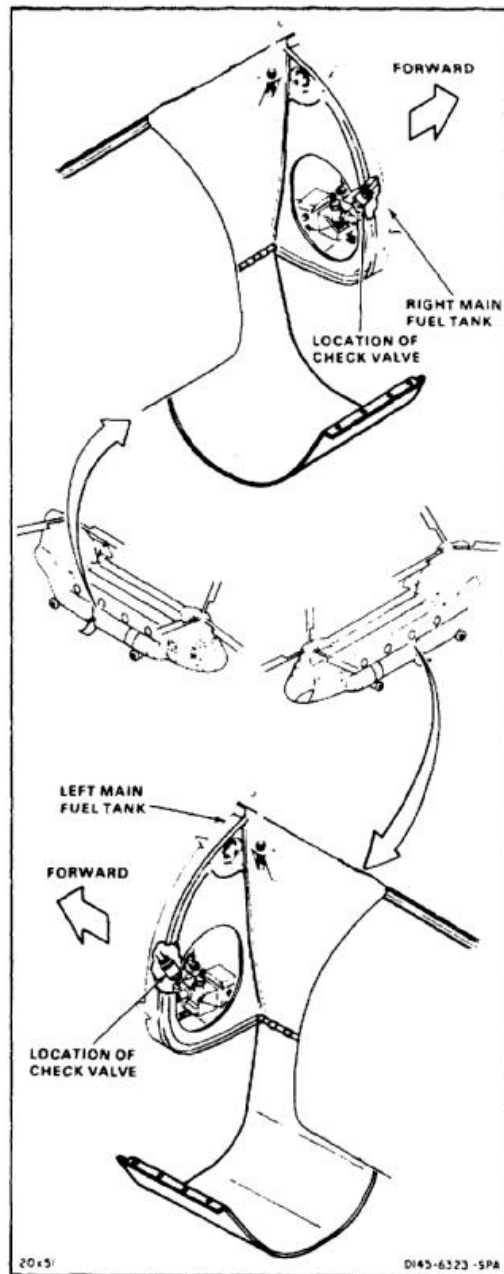

CAUTION

Do not puncture or scratch lining of fuel tank. If lining is broken, fuel penetrates and activates self-sealing layers. Activated layers swell and trap fuel. Activated green spongy material also contaminates fuel system. This makes it necessary to replace fuel tank and flush fuel system.

NOTE

Procedure is same to remove suction feed check valve from No. 1 or No. 2 main fuel tank. Removal of No. 2 (right) valve is shown here.

1. Remove bolt (1) and washer (2) from mounting bracket (3).
2. Disconnect bonding jumper (4). Install washer (2) and bolt (1).
3. Remove nut (5), washer (6), bolt (7), and spacer (8).
4. Disconnect tube (9) from check valve (10).
5. Remove check valve (10), bellmouth tube (11), clamp (12), and bonding jumper (4) as a unit.
6. Cover access hole (13) in tank (14). Use barrier material (E80) and tape (E388).
7. Disconnect bellmouth tube (11) from valve (10).
8. Remove clamp (12).

FOLLOW-ON MAINTENANCE:

None

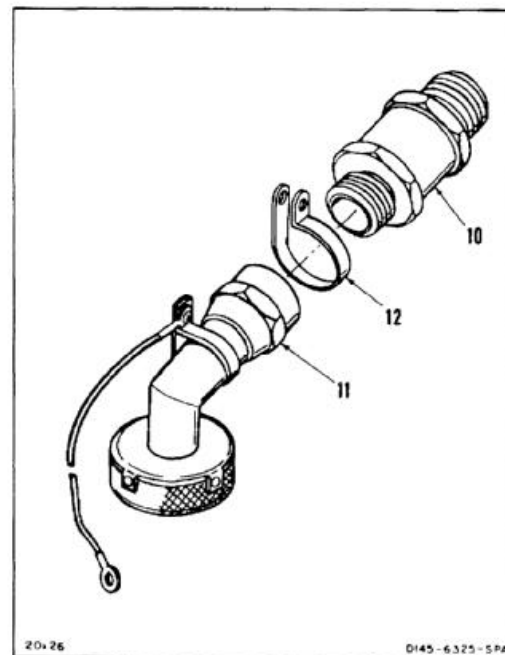
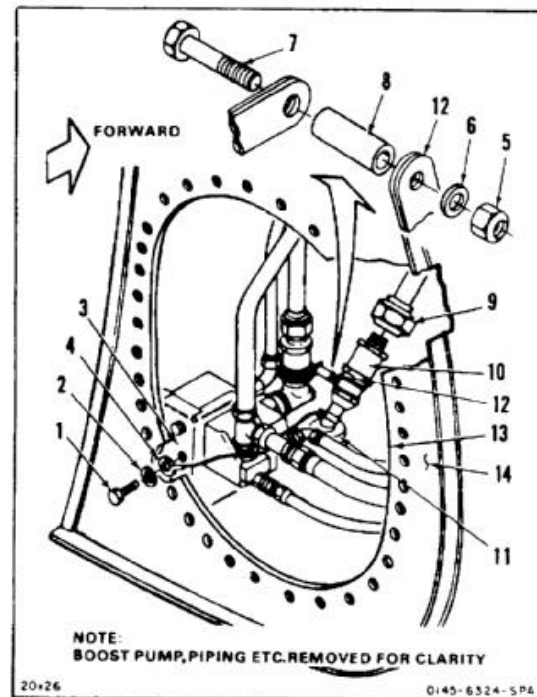

END OF TASK

INITIAL SETUP

Applicable Configurations:

All

Tools:

Aircraft Mechanic's Tool Kit, NSN 5180-00-323-4692

Materials:

- Cloths (E120)
- Dry Cleaning Solvent (E162)
- Gloves (E186)

Personnel Required:

- Medium Helicopter Repairer
- Inspector

References:

TM 55-1520-240-23P

General Safety Instructions:

WARNING

All regulations and instructions for handling fuels shall be strictly observed.

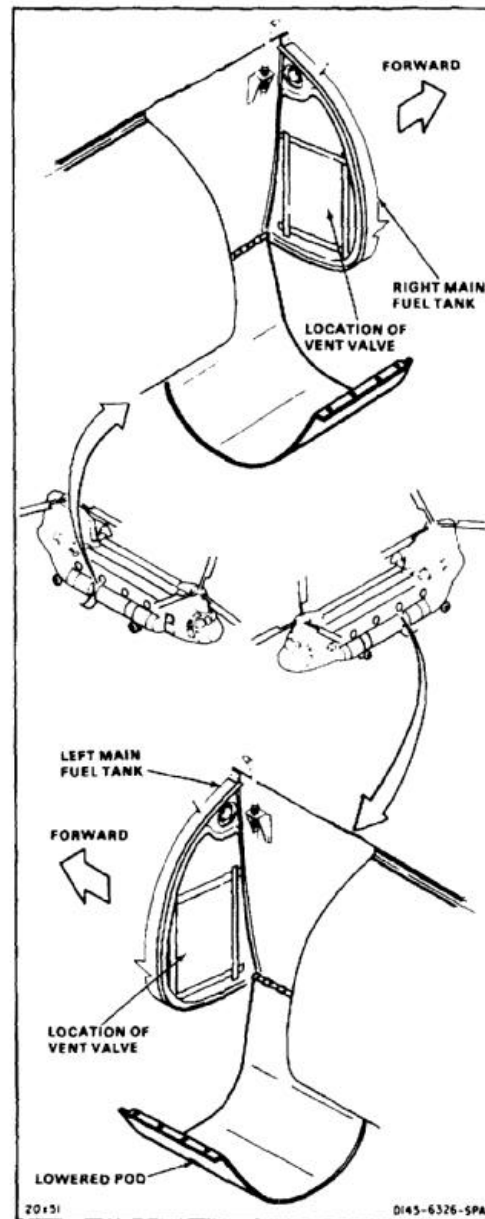

NOTE

Procedure is same to install suction feed check valve in No. 1 or No. 2 main fuel tank. Installation of No. 2 (right) valve is shown here.

1. Install clamp (1) on bellmouth tube (2).
2. Connect bellmouth tube connector (3) to check valve (4).

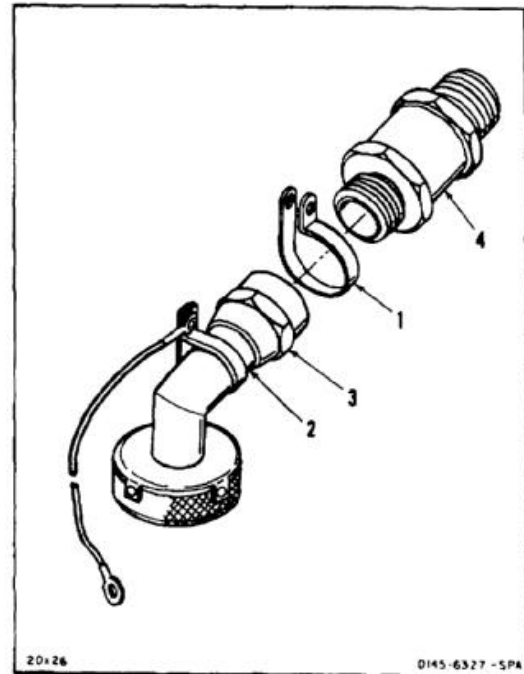

WARNING

Dry cleaning solvent (E162) is flammable and toxic. It can irritate skin and cause burns. Use only in well-ventilated area, away from heat and open flame. In case of contact, immediately flush skin or eyes with water for at least **15 minutes**. Get medical attention for eyes.

3. Remove barrier material and tape from main fuel tank (5). Remove tape residue from tank. Use dry cleaning solvent (E162) and cloths (E120). Wear goggles to protect eyes. Wear gloves (E186).

CAUTION

Do not puncture or scratch lining of fuel tank. If lining is broken, fuel penetrates and activates self-sealing layers. Activated layers swell and trap fuel. Activated green spongy material also contaminates fuel system. This makes it necessary to replace fuel tank and flush fuel system.

4. Position check valve (4), bellmouth tube (2), clamp (1), and bonding jumper (6) as a unit.
5. Connect tube (7) to check valve (4).
6. Position spacer (8) and clamp (1). Install bolt (9), washer (10), and nut (11).
7. Remove bolt (12) and washer (13) from mounting bracket (14).
8. Position bonding jumper (6). Install washer (13) and bolt (12).

INSPECT**FOLLOW-ON MAINTENANCE:**

Perform vent system pressure test (Task 10-117).
 Install main fuel tank aft access door (Task 10-54).
 Test main fuel tank (Task 10-22).
 Perform vent system flow test (Task 10-118).
 Perform test of pressure refueling system (Task 10-119) and fuel feed system (Task 10-120).
 Refuel helicopter (Task 1-51).
 Bleed fuel system (Task 10-121).
 Perform operational check of fuel system (TM 55-1520-240-T).
 Inspect for leaks (Task 10-4).
 Close and latch aft intertank pod panel (Task 2-188).

END OF TASK

10-316

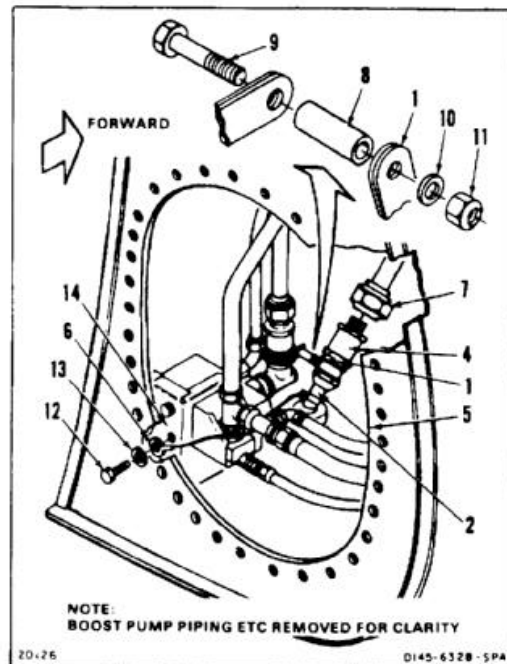

10-63 REMOVE FUEL TANK VENT FAIRING**10-63****INITIAL SETUP****Applicable Configurations:**

All

Tools:

Aircraft Mechanic's Tool Kit, NSN 5180-00-323-4692

Materials:

None

Personnel Required:

Medium Helicopter Repairer

Equipment Condition:

Battery Disconnected (Task 1-39)

Electrical Power Off

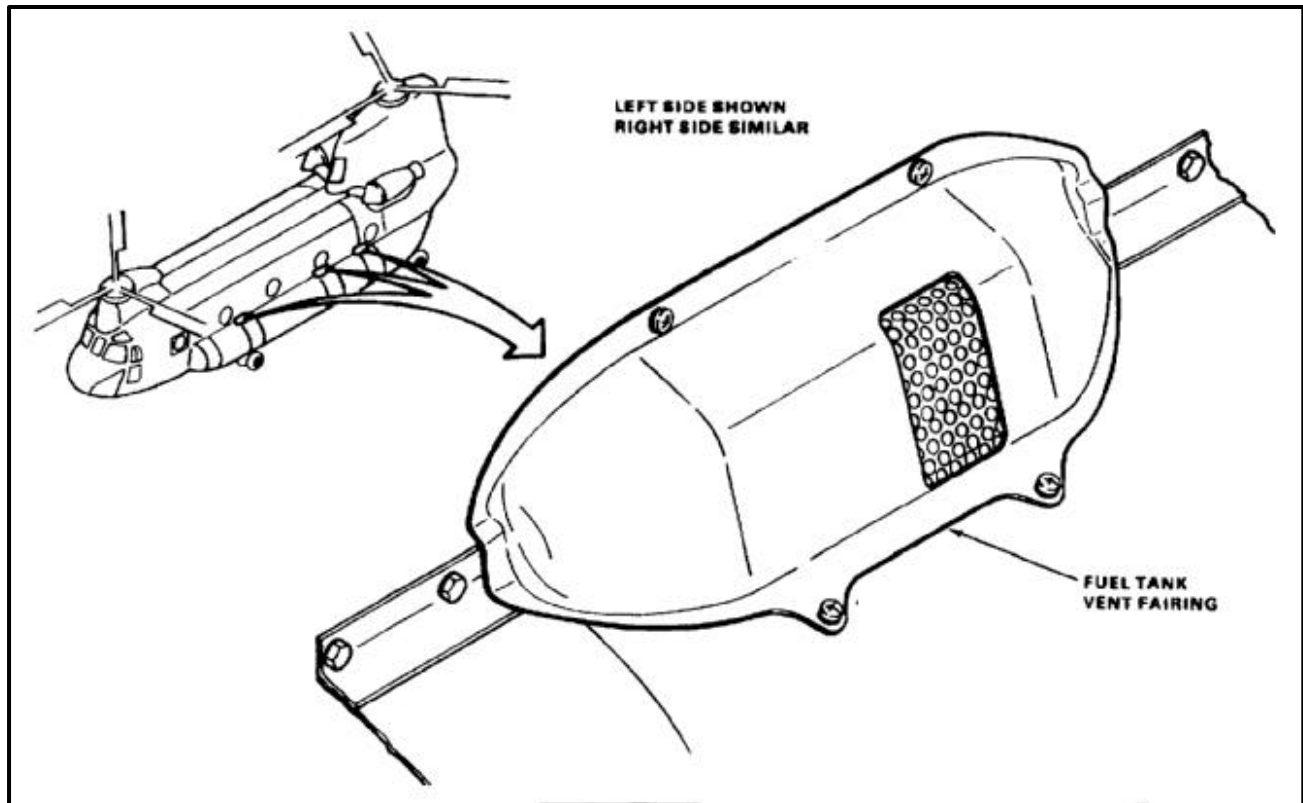

NOTE

Procedure is same to remove any of six fuel tank vent fairings. Removal of left side main tank vent fairing is shown here.

1. Remove two screws (1) and washers (2).
2. Remove two screws (3) and washers (4).
3. Slide vent fairing (5) aft to disengage baffle (6) from vent tube (7).
4. Remove fairing (5).

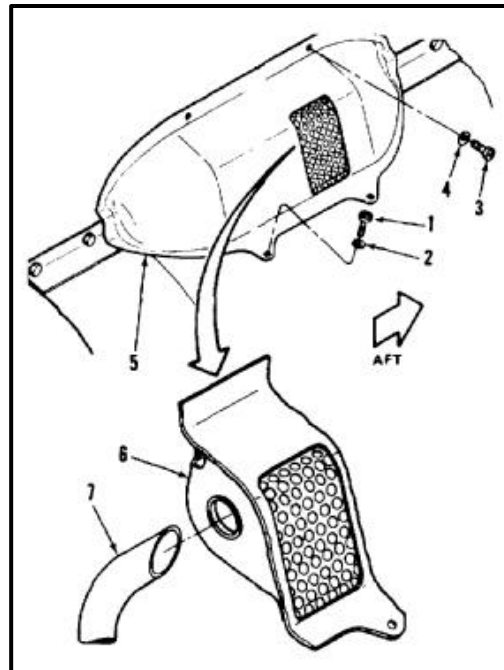
**FOLLOW-ON MAINTENANCE:**

None

END OF TASK

10-318

INITIAL SETUP

Applicable Configurations:

All

Tools

Aircraft Mechanic's Tool Kit, NSN 5180-00-323-4692

Materials:

None

Personnel Required:

Medium Helicopter Repairer
Inspector

References:

TM 55-1520-240-23P

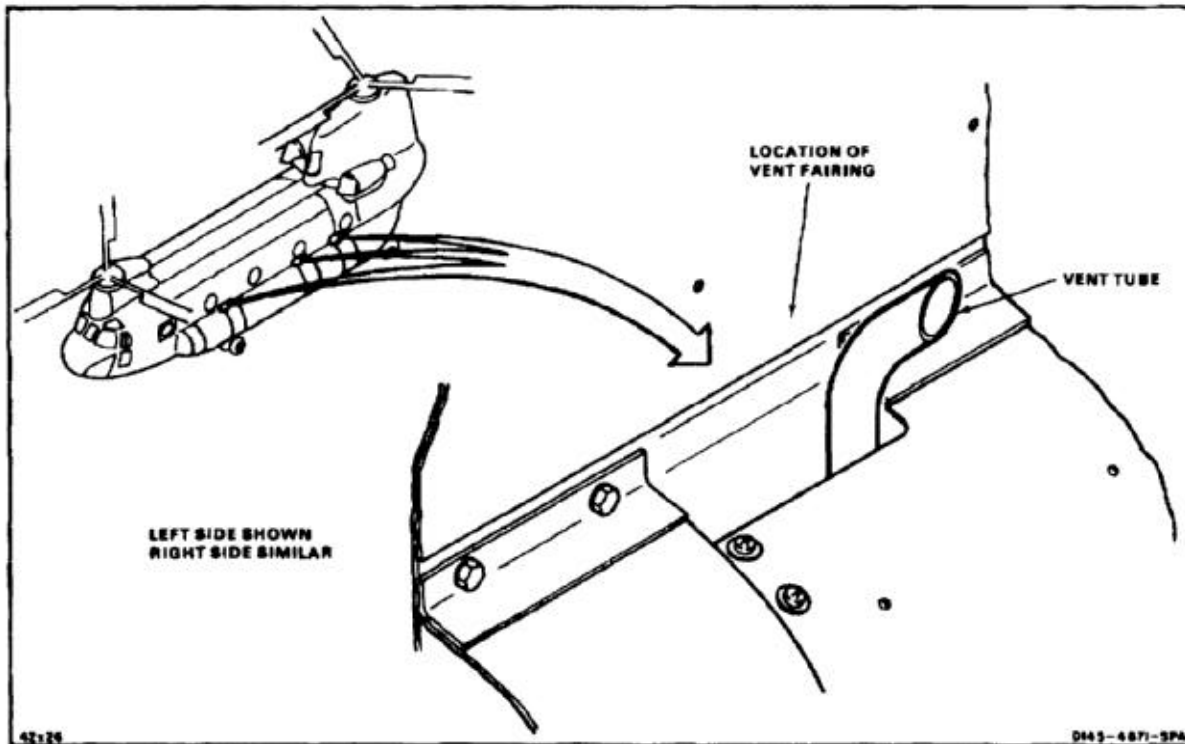

NOTE

Procedure is same to install any of six fuel tank vent fairings. Installation of left side main tank vent fairing is shown here.

1. Position fairing (1) aft of vent tube (2). Align hole in baffle (3) with end of tube. Slide fairing forward.
2. Align four holes (4) in fairing (1) with holes in pod (5) and fuselage (6).
3. Install two screws (7) and washers (8).
4. Install two screws (9) and washers (10).

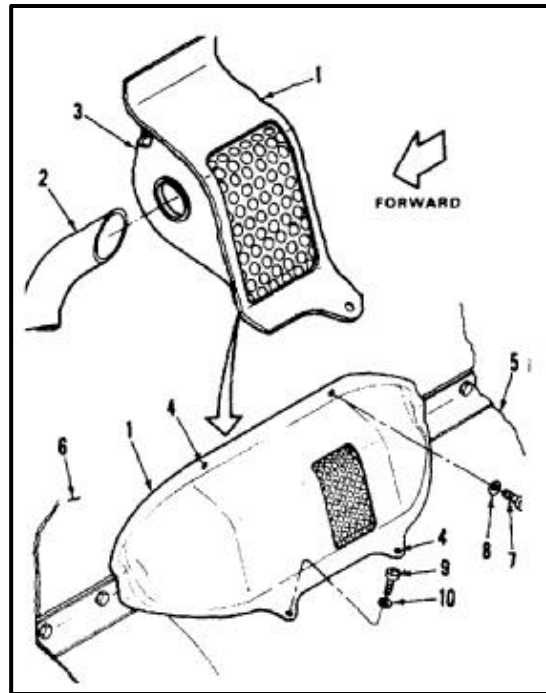
INSPECT**FOLLOW-ON MAINTENANCE:**

None

END OF TASK

10-320

10-65 REMOVE FORWARD OR AFT FUEL TANK VENT ASSEMBLY**10-65****INITIAL SETUP****Applicable Configurations:**

All

Tools:

Aircraft Mechanic's Tool Kit, NSN 5180-00-323-4692

Materials:

Barrier Material (E80)
Tape (E388)
Paper Tags (E264)

Personnel Required:

Medium Helicopter Repairer

Equipment Condition:

Battery Disconnected (Task 1-39)
Electrical Power Off
Helicopter Grounded (Task 1-29)
Affected Side of Helicopter Defueled (Task 10-34 or 10-35)
Fuel Quantity Transmitter Removed (Task 8-81)

For Forward Fuel Tank Vent Assembly Removal (Only), Lower Fuel Tank on Hinges (Task 10-23)
Forward Access Door Removed on Forward or Aft Auxiliary Tank (Task 10-69 or 10-79)

General Safety Instructions:**WARNING**

All regulations and instructions for handling fuel shall be strictly observed.

CAUTION

Do not puncture or scratch lining of fuel cell. If lining is broken, fuel penetrates and activates self-sealing layers. Activated layers swell and trap fuel. Activated green spongy material also contaminates fuel system. This makes it necessary to replace fuel cell and flush fuel system.

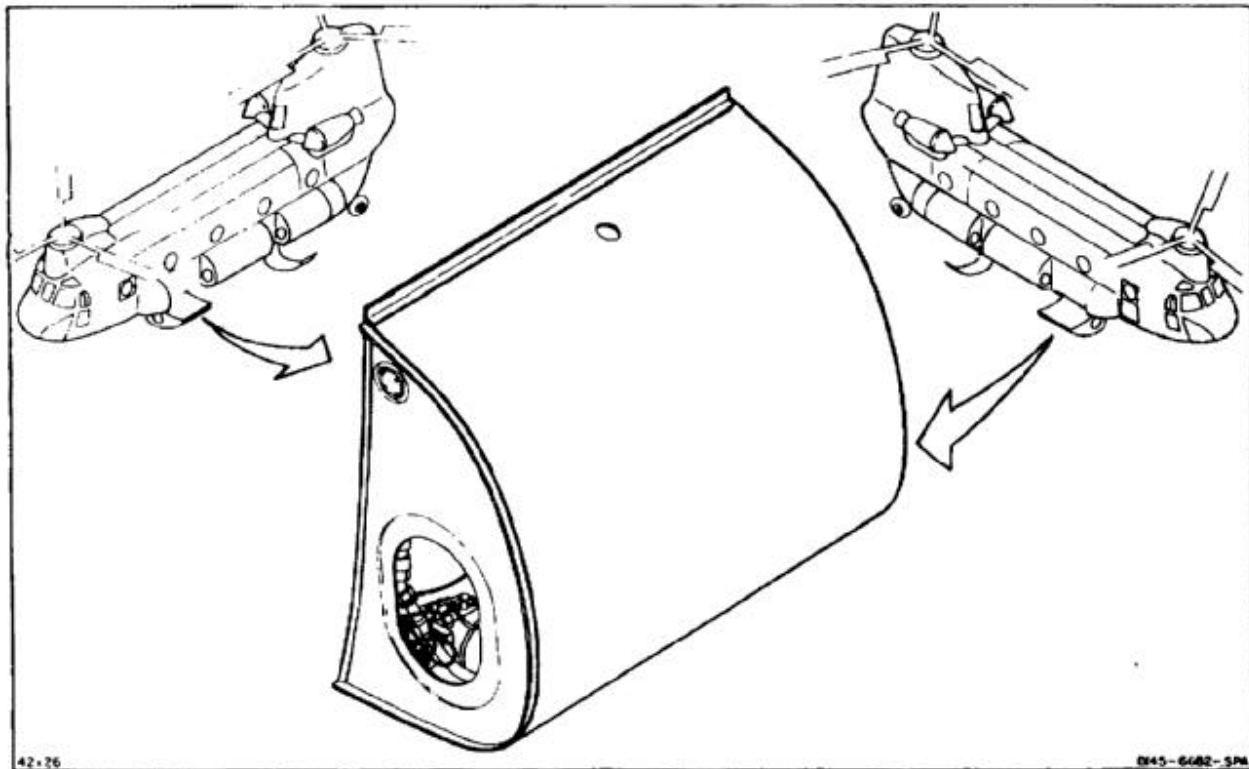

NOTE

Procedure is same to remove No. 1 or No. 2 forward or aft auxiliary fuel tank vent assembly. No. 1 (left) forward auxiliary fuel tank vent assembly is shown here.

1. On forward fuel tank only, remove nut (1), washer (2), screws (3), and spacer (4).
2. On forward fuel tank only, remove two nuts (5), washers (6), and screws (7).
3. Disconnect hose connectors (8 and 9). Tag and remove hose (10).
4. Disconnect hose connectors (11 and 12).
5. Remove nut (13), washer (14), and screw (15).
6. Remove two screws (16) and washers (17).
7. Disconnect hose connector (19). Tag and remove hose (20) and ring (21).
8. Remove three screws (22), washers (23), and spacers (24). Tag each screw and spacer for correct location.

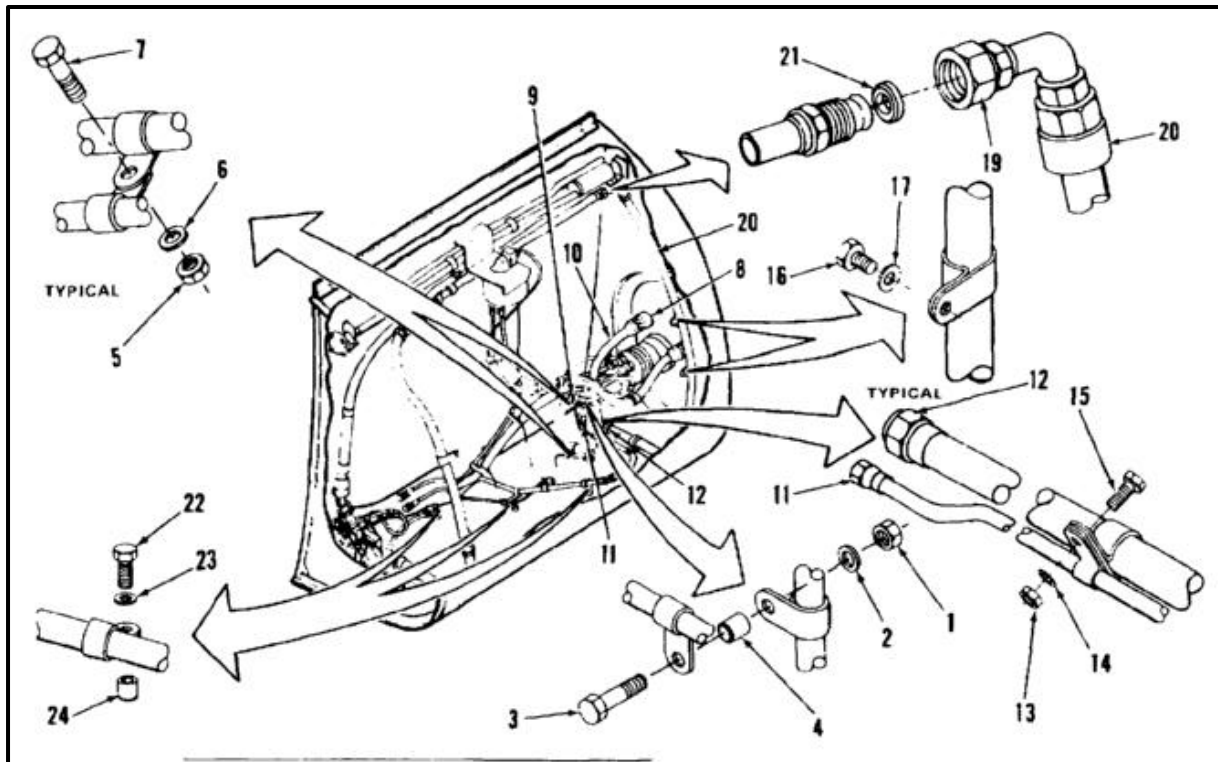

10-65 REMOVE FORWARD OR AFT FUEL TANK VENT ASSEMBLY (Continued)

- | | |
|---|---|
| <p>9. Remove nut (25), washer (26), and screw (27).</p> <p>10. Remove nut (28), washer (29), and screw (30).</p> <p>11. Remove nut (31), washer (32) and screw (33).</p> <p>12. Disconnect hose connector (34). Tag and remove tube assembly (35).</p> <p>13. Disconnect hose connectors (36) and (37). Remove two rings (38).</p> <p>14. Remove two screws (39), washers (40). Tag and remove hose (41).</p> | <p>15. On aft tank only, remove nut (42), washer (43), and screw (44).</p> <p>16. Disconnect hose connectors (45) and (46). Remove ring (38).</p> <p>17. Remove screw (47) and washer (48). Tag and remove hose (49).</p> <p>18. Remove screw (50), washer (51), and spacer (52).</p> <p>19. Remove screw (53), washer (54), and spacer (55). Tag and remove tube (56).</p> |
|---|---|

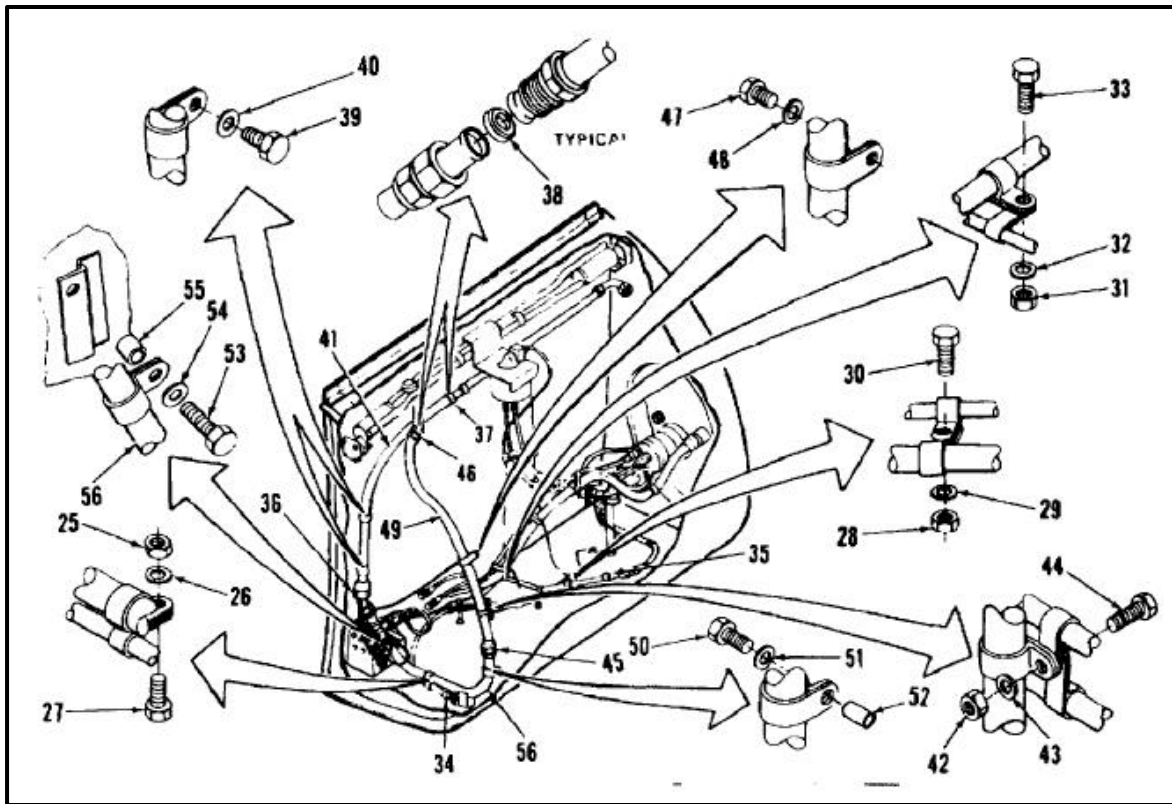

20. Remove nut (57), washer (58), and screw (59).
21. Remove four nuts (60), washers (61), and screws (62). Tag and remove vent assembly (63).
22. Cover access (64). Use barrier material (E80) and tape (E388).

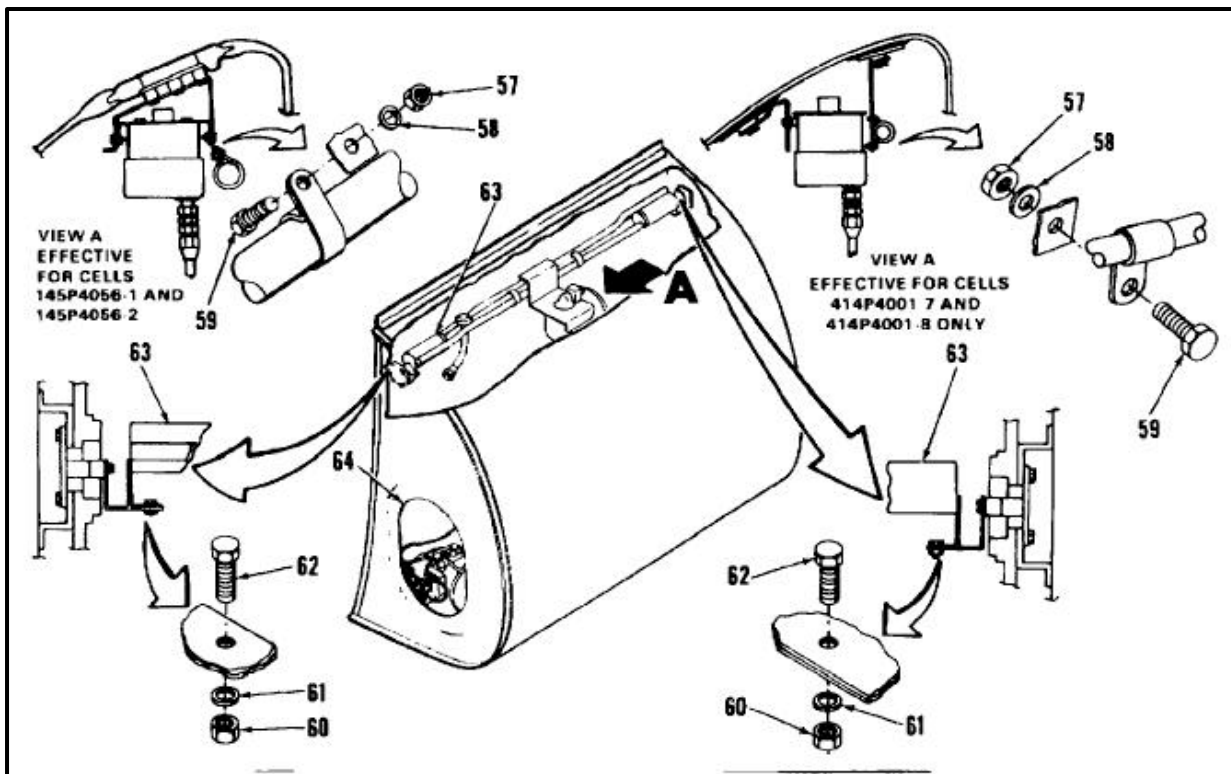

FOLLOW-ON MAINTENANCE:

None

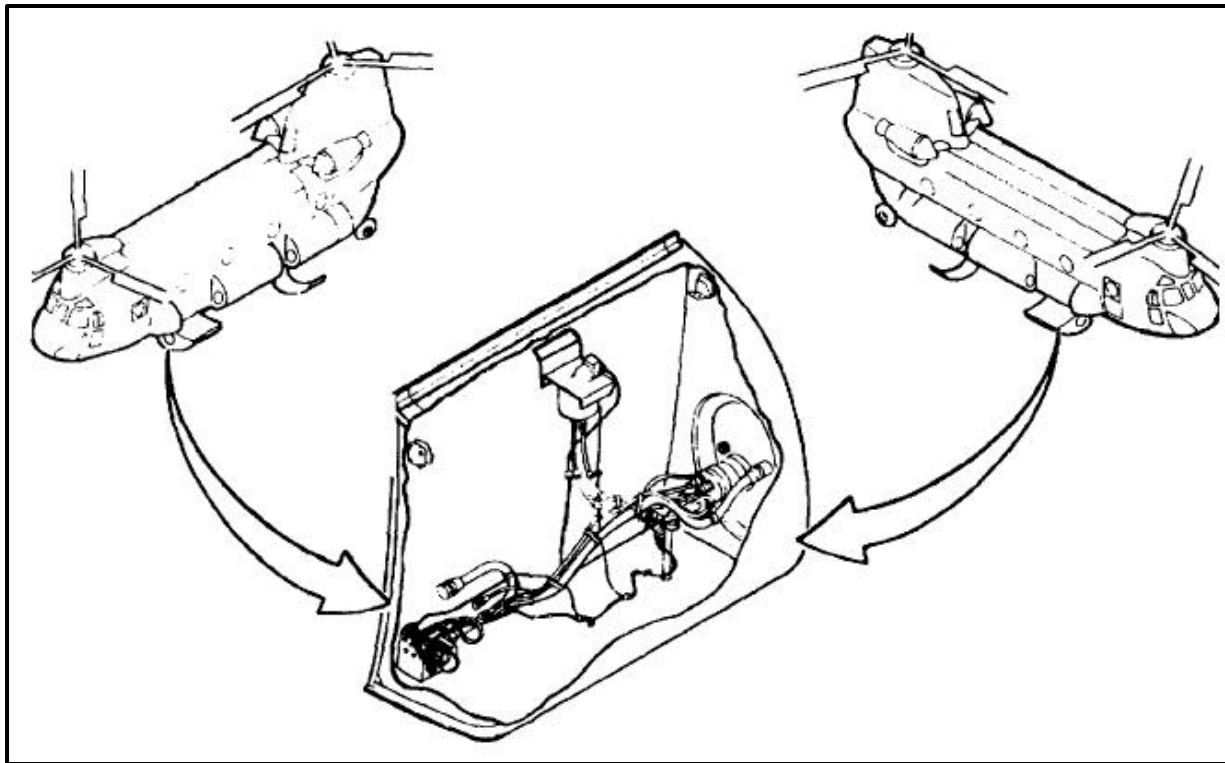

END OF TASK

INITIAL SETUP

Applicable Configurations:

All

Tools:

Aircraft Mechanic's Tool Kit, NSN 5180-00-323-4692

Materials:

Cloths (E135)
 Dry Cleaning Solvent (E162)
 Gloves (E184.1)

Personnel Required:

Medium Helicopter Repairer
 Inspector

References:

TM 55-1520-240-23P
 TM 55-1520-240-T

General Safety Instructions:**WARNING**

All regulations and instructions for handling fuels shall be strictly observed.

CAUTION

Do not puncture or scratch lining of fuel cell. If lining is broken, fuel penetrates and activates self-sealing layers. Activated layers swell and trap fuel. Activated green spongy material also contaminates fuel system. This makes it necessary to replace fuel cell and flush fuel system.

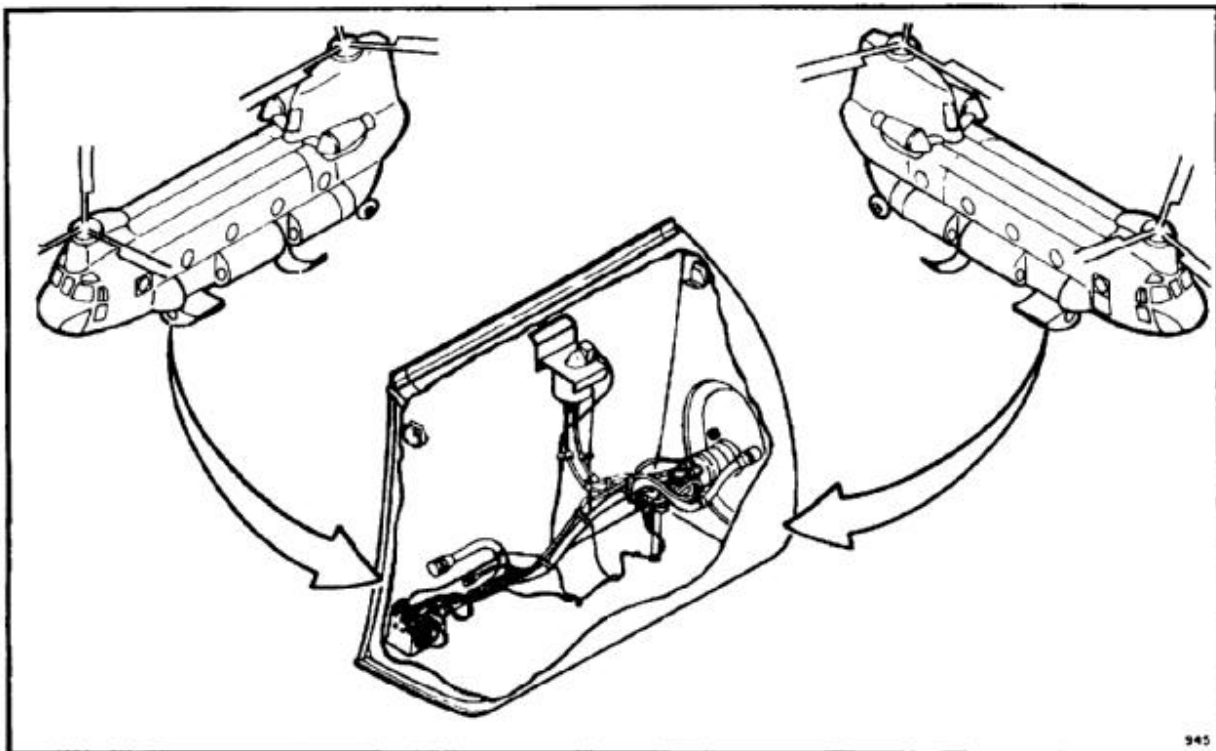

WARNING

Dry cleaning solvent (E162) is flammable and toxic. It can irritate skin and cause burns. Use only in well-ventilated area, away from heat and open flame. In case of contact, immediately flush skin or eyes with water for at least **15 minutes**. Get medical attention for eyes.

NOTE

Procedure is same to install No. 1 and No. 2 forward or aft fuel tank vent assembly. No. 1 (left) forward fuel tank vent assembly is shown here.

1. Remove barrier material and tape from forward access hole (1).

2. Remove tape residue from face of tank (2). Use dry cleaning solvent (E162) and cloths (E135). Wear goggles to protect eyes. Wear gloves (E184.1).
3. Position vent assembly (3) on two brackets (4). Install four screws (5), washers (6), and nuts (7).

NOTE

If required, a stand off spacer tube may be used to allow clearance between the bracket and the control valve. Tube length should be as required.

4. Position clamp (8). Install screw (9), washer (10), and nut (11).

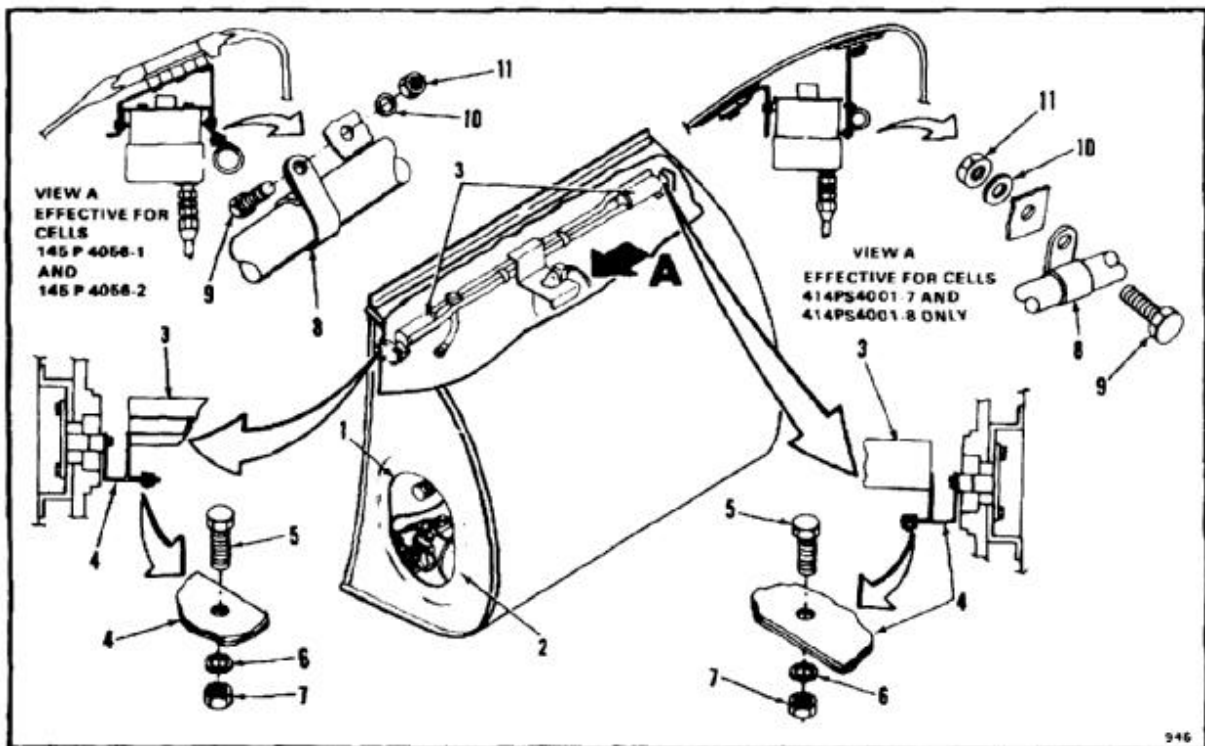

946

5. Remove tags and position tube (12) and clamp (13). Install screw (14), washer (15), and spacer (16).
6. Position clamp (17) and spacer (18). Install screw (19) and washer (20).
7. Remove tags and position hose (21) and ring (22). Connect hose connectors (23 and 24).
8. Position clamp (25). Install screw (26) and washer (27).
9. On aft tank only, position hose clamp (28) and two hose clamps (29 and 30).
10. Install screw (31), washer (32) and nut (33).
11. Remove tags and position hose (34). Position ring (22) at each end of hose. Connect hose connectors (35 and 36).
12. Position two clamps (37). Install two screws (38) and washers (39).
13. Remove tags and position pipe assembly (40). Connect hose connector (41).
14. Position clamps (42 and 43). Install screw (44), washer (45), and nut (46).
15. Position clamps (47 and 48). Install screw (49), washer (50), and nut (51).
16. Position clamps (52 and 53). Install screw (54), washer (55), and nut (56).

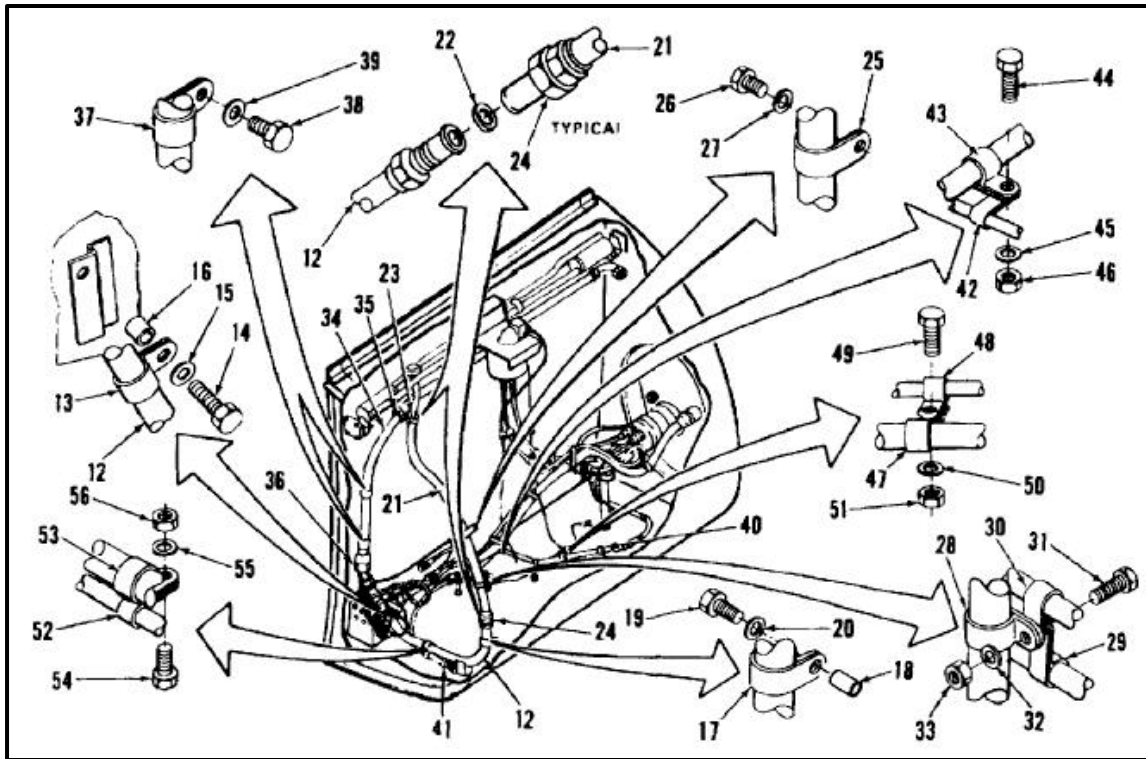

NOTE

Pipe assembly (40) must be positioned so that no high or low spots in the assembly can trap fluids. Clamps and spacers must be positioned to remove slack in hose and ensure a level tube.

17. Remove tags from three spacers (57) and position as indicated.
18. Position three clamps (58). Install three washers (59) and screws (60).
19. Check that no high or low points occur in pipe assembly (40).
20. Remove tags and position hose (61) and ring (62). Connect hose connectors (63 and 64).
21. Position two clamps (65). Install two washers (67) and screws (68).
22. Connect hose connector (69). Position clamps (70 and 71). Install screw (72), washer (73), and nut (74).
23. Remove tags and position hose (75). Connect hose connectors (76 and 77).
24. On forward fuel tank only, position two clamps (78 and 79). Install two screws (80), washers (81), and nuts (82).
25. On forward fuel tank only, position two clamps (83 and 84) and spacer (85). Install screw (86), washer (87), and nut (88).

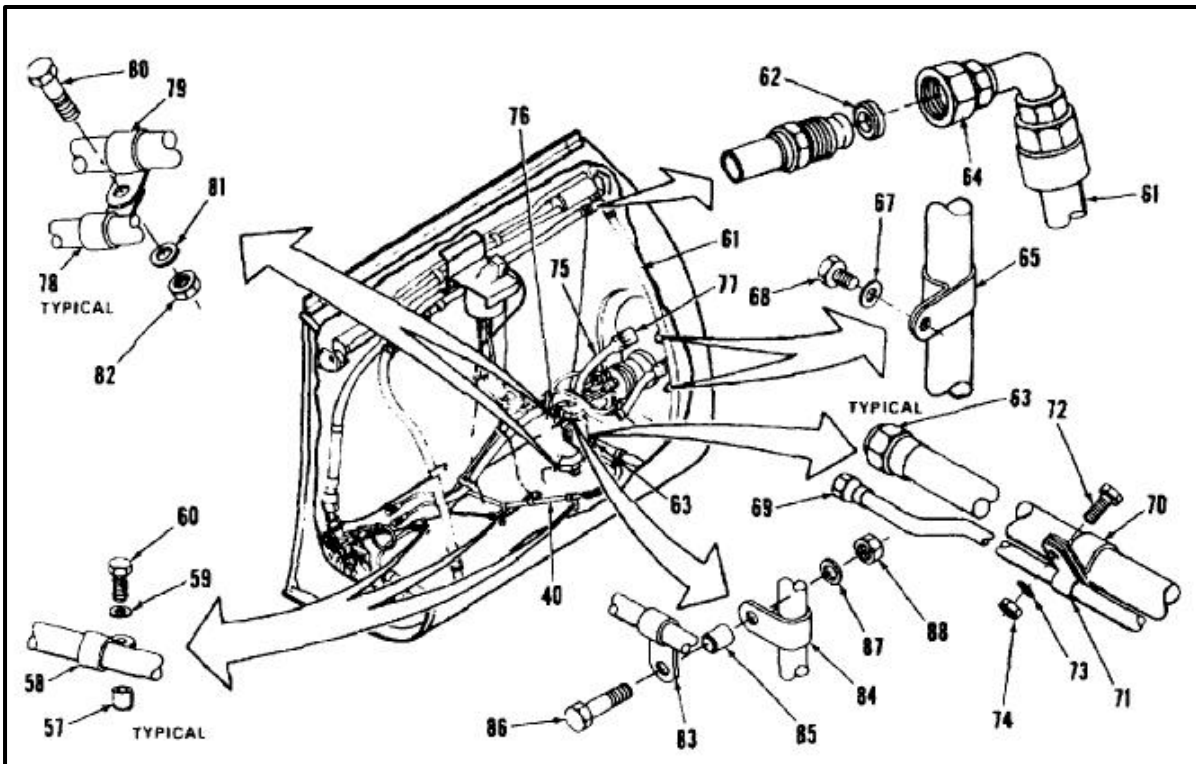

INSPECT**FOLLOW-ON MAINTENANCE:**

- Pressure test vent system (Task 10-117).
- Install forward access door on forward or aft auxiliary tank (Task 10-70 or 10-80).
- For forward auxiliary fuel tank only, raise fuel tank on hinges (Task 10-26).
- Install fuel quantity transmitter (Task 8-82).

- Test fuel tank after installation (Task 10-27 or 10-32).
- Perform vent system flow test (Task 10-118).
- Perform test of pressure refueling system (Task 10-119) and fuel feed system (Task 10-120).
- Refuel helicopter (Task 1-51).
- Bleed fuel system (Task 10-121).
- Check for leaks (Task 10-4).
- Perform operational check of fuel system (TM 55-1520-240-T).

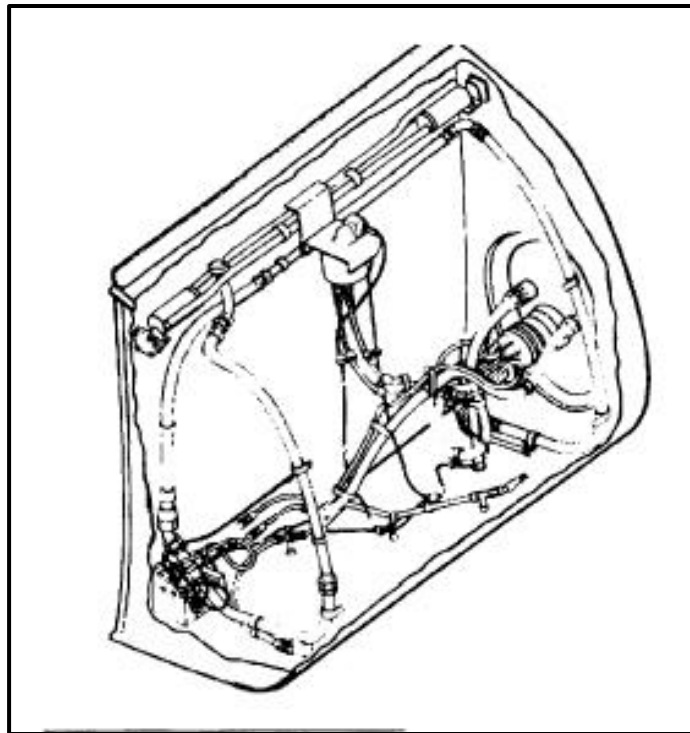

END OF TASK

10-330

10-67 REMOVE FORWARD TANK FUEL LINES, AND ELECTRICAL WIRING

10-67

INITIAL SETUP

Applicable Configurations:

All

Tools:

Aircraft Mechanic's Tool Kit, NSN 51 80-00-323-4692

Materials:

- Barrier Material (E80)
- Tape (E388)
- Paper Tags (E264)

Personnel Required:

Medium Helicopter Repairer

Equipment Condition:

- Battery Disconnected (Task 1-39)
- Electrical Power Off
- Helicopter Grounded (Task 1-29)
- Forward Tank Defueled (Task 10-34 or 10-35)
- Fuel Quantity Transmitter Removed (Task 8-81)
- Forward Fuel Tank Lowered On Hinges (Task 10-23)
- Forward Fuel Tank Boost Pump Removed (Task 10-69)

General Safety Instructions:

WARNING

All regulations and instructions for handling fuel shall be strictly observed.

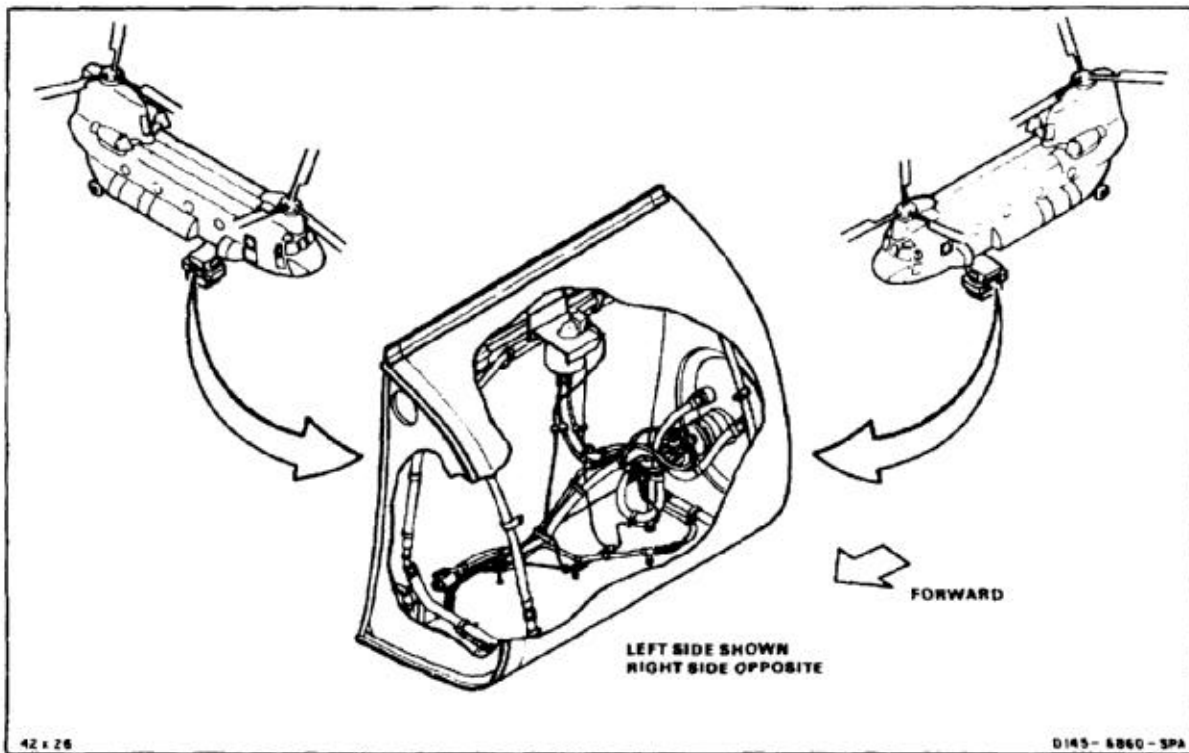

NOTE

Procedure is same to remove No. 1 or No. 2 forward tank fuel lines and electrical wiring. No. 1 (left) forward tank removal is shown here.

1. Remove lockwire and disconnect three electrical connectors (1).
2. Remove lockwire and three locknuts (2).
3. Push three electrical receptacles (3) into fuel tank (4). Cover holes in tank. Use barrier material (E80) and tape (E388).

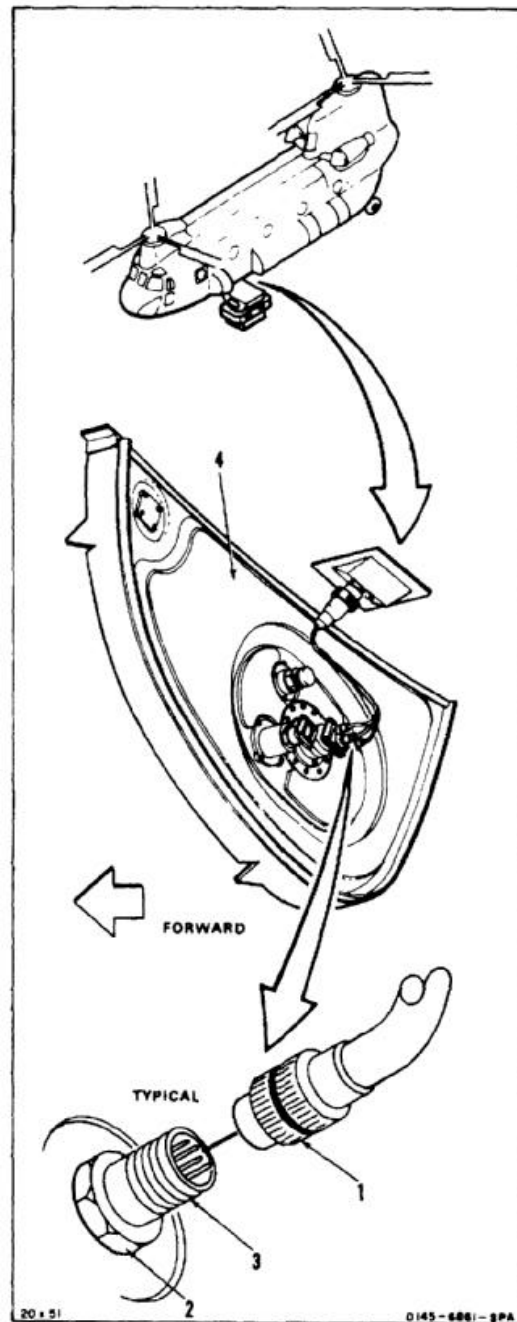

10-67 REMOVE FORWARD TANK FUEL LINES, AND ELECTRICAL WIRING (Continued)**10-67**

4. Remove four screws (5 and 6) and washers (7 and 8). Tag and disconnect four electrical wire terminals (9 and 10). Install four screws and washers.
5. Remove screw (11) and washer (12). Disconnect cable clamp (13). Install screw and washer.
6. Remove screw (14), washer (15), and spacers (16). Disconnect two hose clamps (17), hose clamp (18), and electrical cable clamp (19) from fuel cell mounting plate (20).
7. Tag and disconnect hose connector (21) and two hose connectors (22).

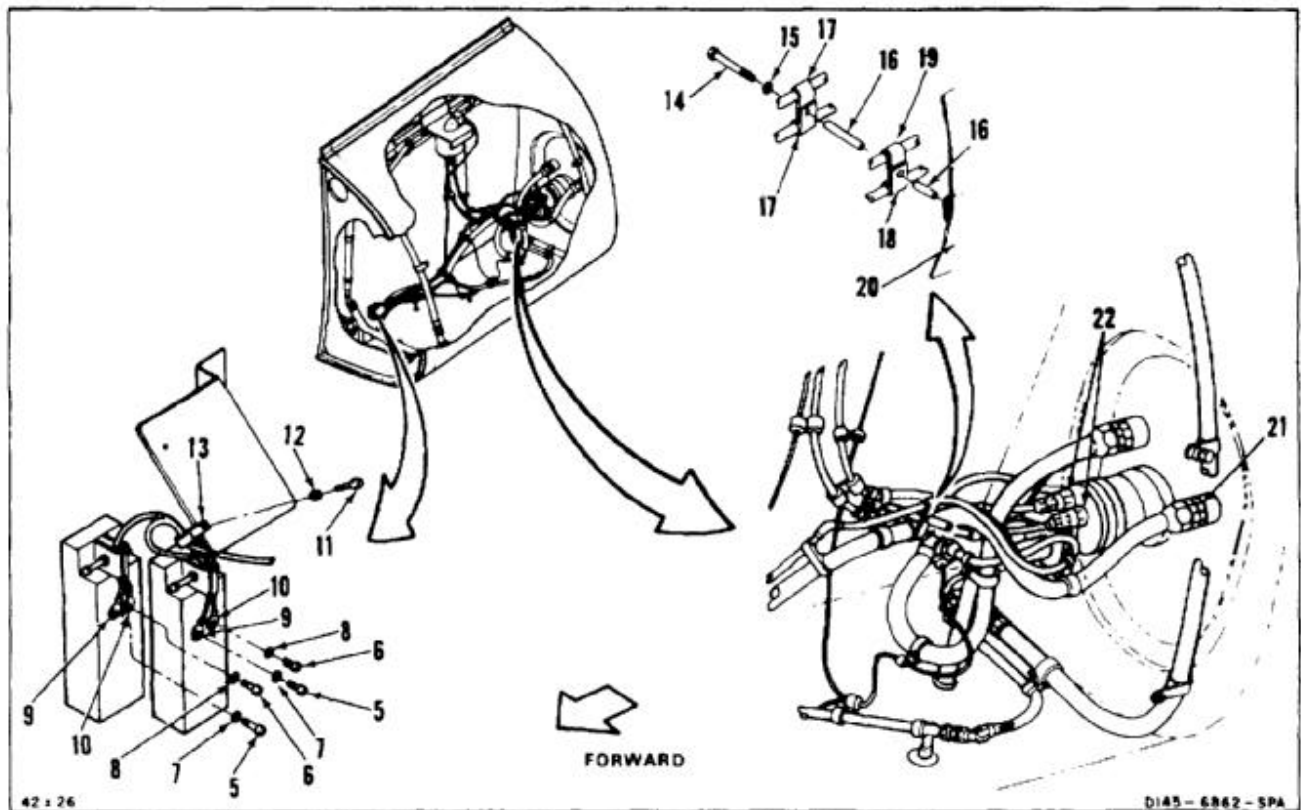

8. Remove screw (23), washer (24) and nut (25). Disconnect two hose clamps (26) from hose clamp (27).
9. Remove screw (28), washer (29) and nut (30). Disconnect electrical wire clamp (31) from electrical cable clamp (32).
10. Tag and remove hose (33) and electrical cable (34) as unit.

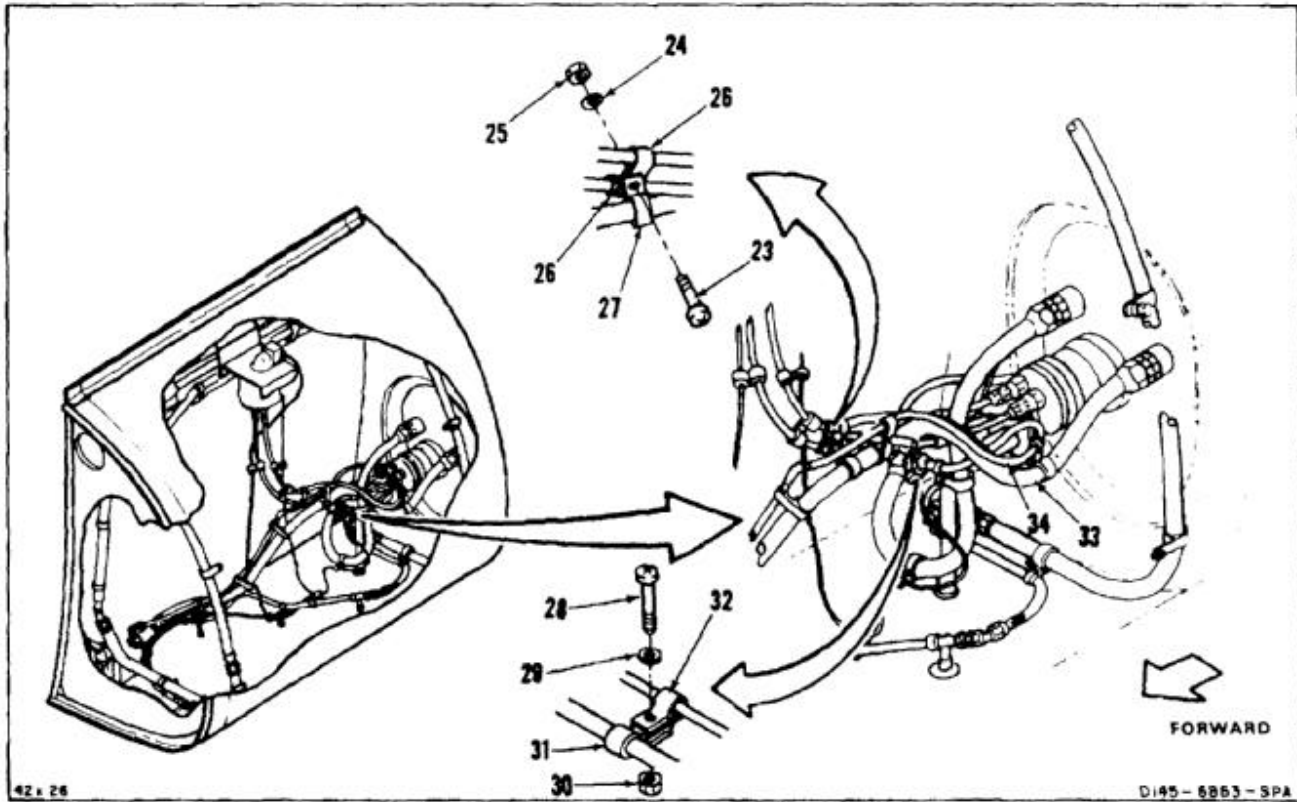

10-67 REMOVE FORWARD TANK FUEL LINES, AND ELECTRICAL WIRING (Continued)**10-67**

11. Remove screw (35), washer (36), and nut (37). Disconnect hose clamp (38) from electrical clamp (39).
12. Remove screw (40), washer (41) and nut (42). Disconnect hose clamp (43) from electrical clamp (44).
13. Disconnect two flexible hose connectors (45) (45).
14. Tag and remove two hose (46) as unit.
15. Remove two screws (47), washers (48) and spacers (49).
16. Remove two screws (50), washers (51) and nuts (52).
17. Tag and remove electrical wires (53).

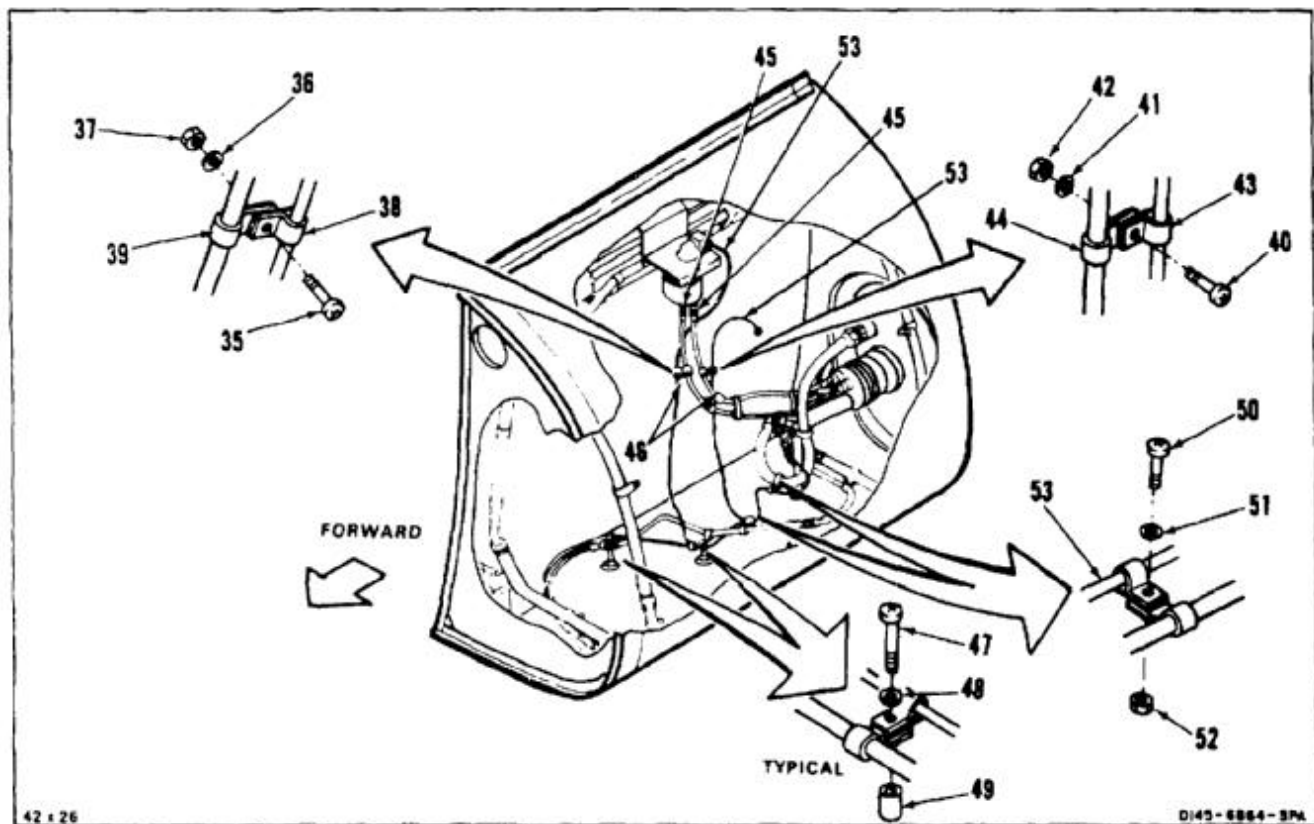

42 x 26

DI45-6864-3PA

18. Cover access hole in end of fuel tank (4). Use barrier material (E80) and tape (E388).

FOLLOW-ON MAINTENANCE:

None

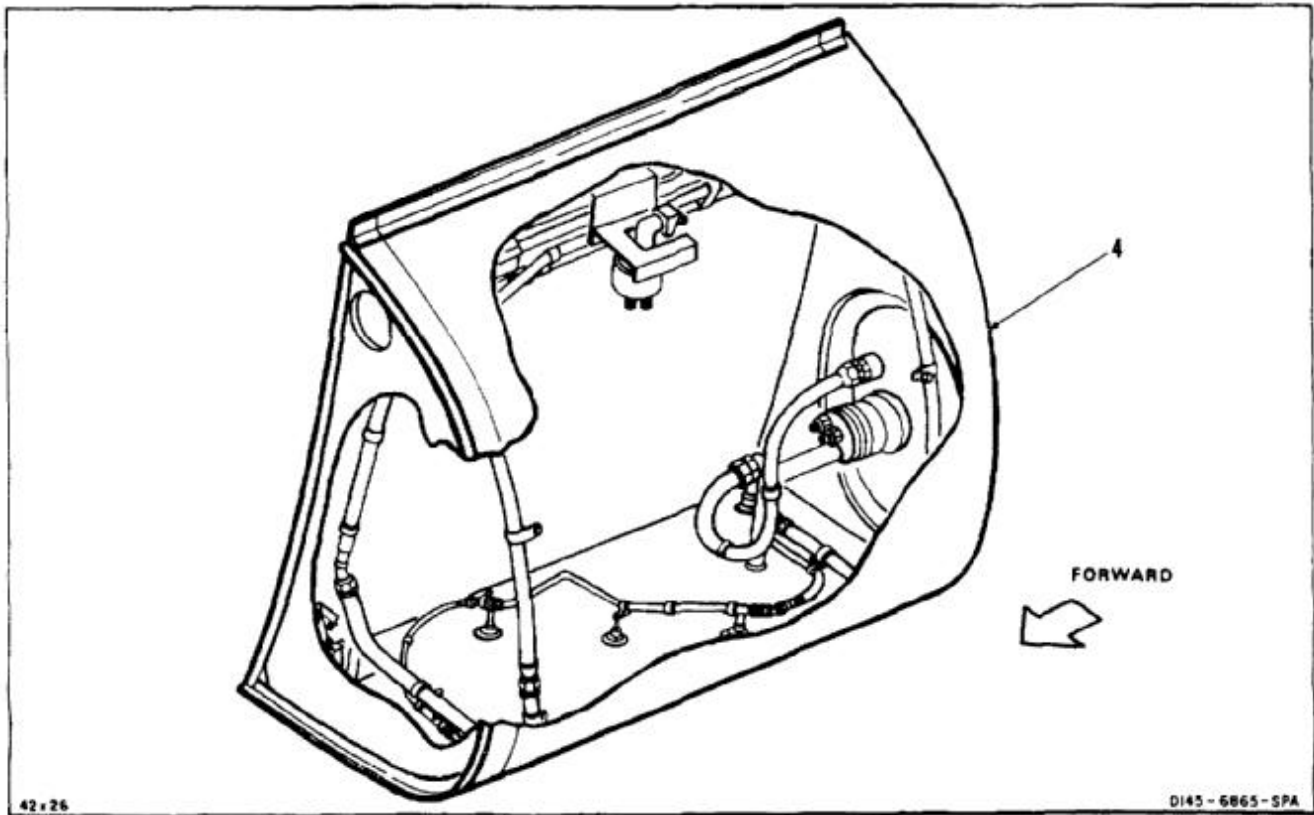

END OF TASK

INITIAL SETUP

Applicable Configurations:

Tools:

Aircraft Mechanic's Tool Kit, NSN 5180-00-323-4692

Materials:

- Dry Cleaning Solvent (E162)
- Gloves (E186)
- Cloths (E135)
- Lockwire (E227)

Personnel Required

- Medium Helicopter Repairer (2)
- Inspector

References:

- Task 1-13
- TM 55-1520-240-23P

General Safety Instructions:

WARNING

All regulations and instructions for handling fuel shall be strictly observed.

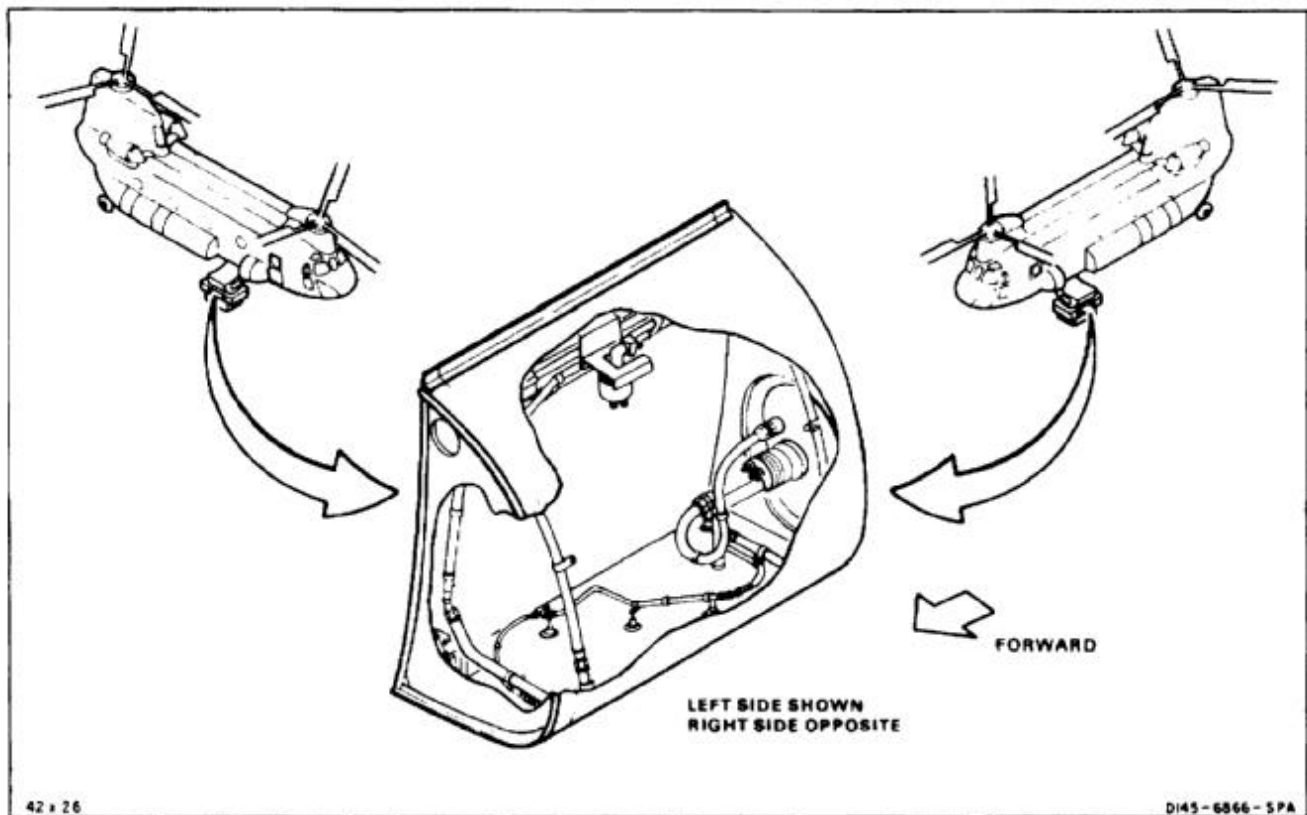

WARNING

Dry cleaning solvent (E162) is flammable and toxic. It can irritate skin and cause burns. Use only in well-ventilated area, away from heat and open flame. In case of contact, immediately flush skin or eyes with water for at least **15 minutes**. Get medical attention for eyes.

NOTE

Procedure is same to install No. 1 or No. 2 forward tank lines and electrical wiring. No. 1 (left) forward tank installation is shown here.

1. Remove barrier material and tape from hole in tank (1). Clean tape residue from tank. Use dry cleaning solvent (E162) and cloths (E135). Wear goggles to protect eyes. Wear gloves (E186).
2. Remove tags and position electrical wires (2).

3. Position two electrical wire clamps (3) and two tube clamps (4). Install two screws (5), washers (6), and nuts (7).
4. Position two tube clamps (8) and two electrical wire clamps (9). Install two screws (10), washers (11), and spacers (12).
5. Remove tags and position two hoses (13).

CAUTION

Extreme care should be applied during installation and inspection to ensure that hose connectors are properly installed. Serious damage could occur to the helicopter if these hose end fittings are not properly torqued. (Refer to Task 1-13.)

6. Connect two hoses connectors (14).
7. Position two electrical clamps (15) on two hose clamps (16). Install two screws (17), washers (18) and nuts (19).

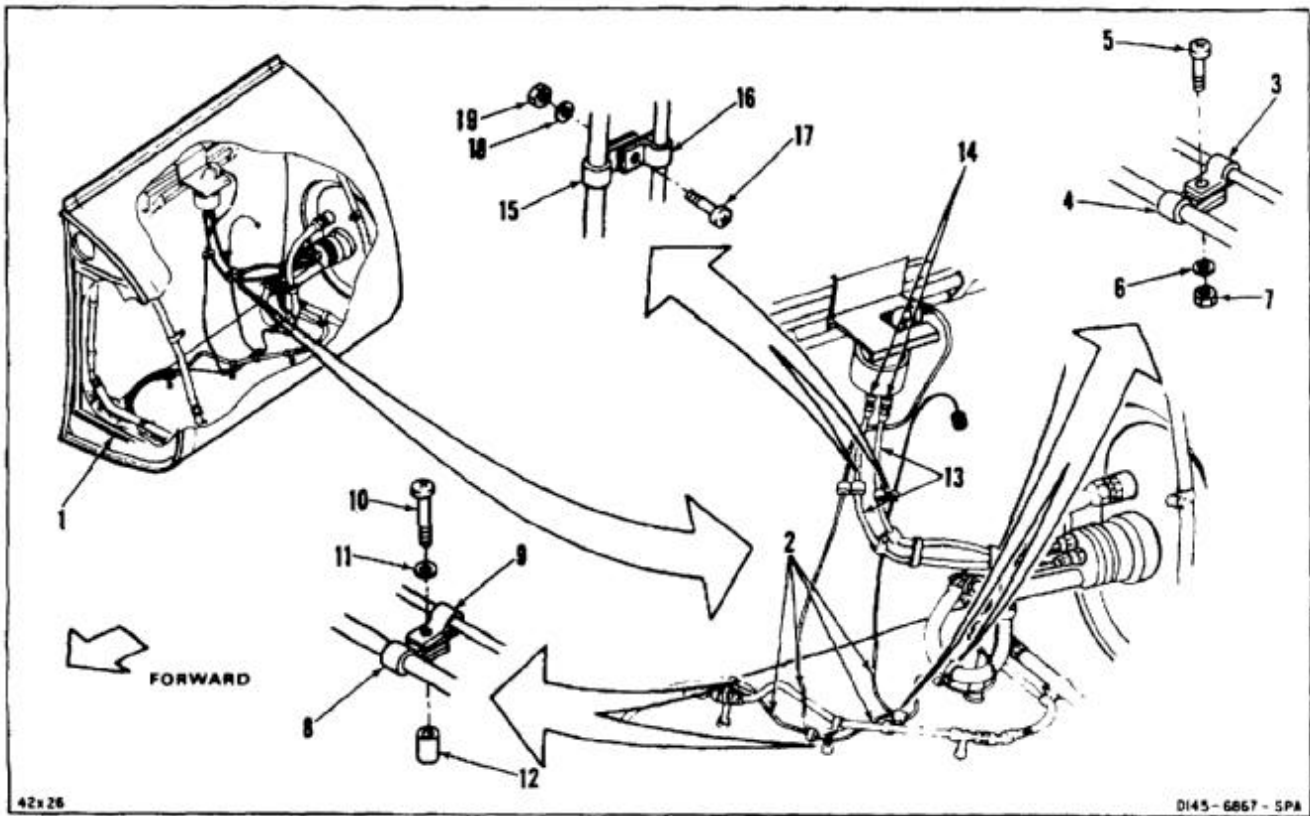

10-68 INSTALL FORWARD TANK FUEL LINES AND ELECTRICAL WIRING (Continued)**10-68**

8. Remove tags and position unit of hose (20) and electrical cable (21).
9. Position electrical cable clamp (22) on electrical wire clamp (23). Install screw (24), washer (25), and nut (26).
10. Position two hose clamps (27 and 28) on hose clamp (29). Install screw (30) washer (31) and nut (32).

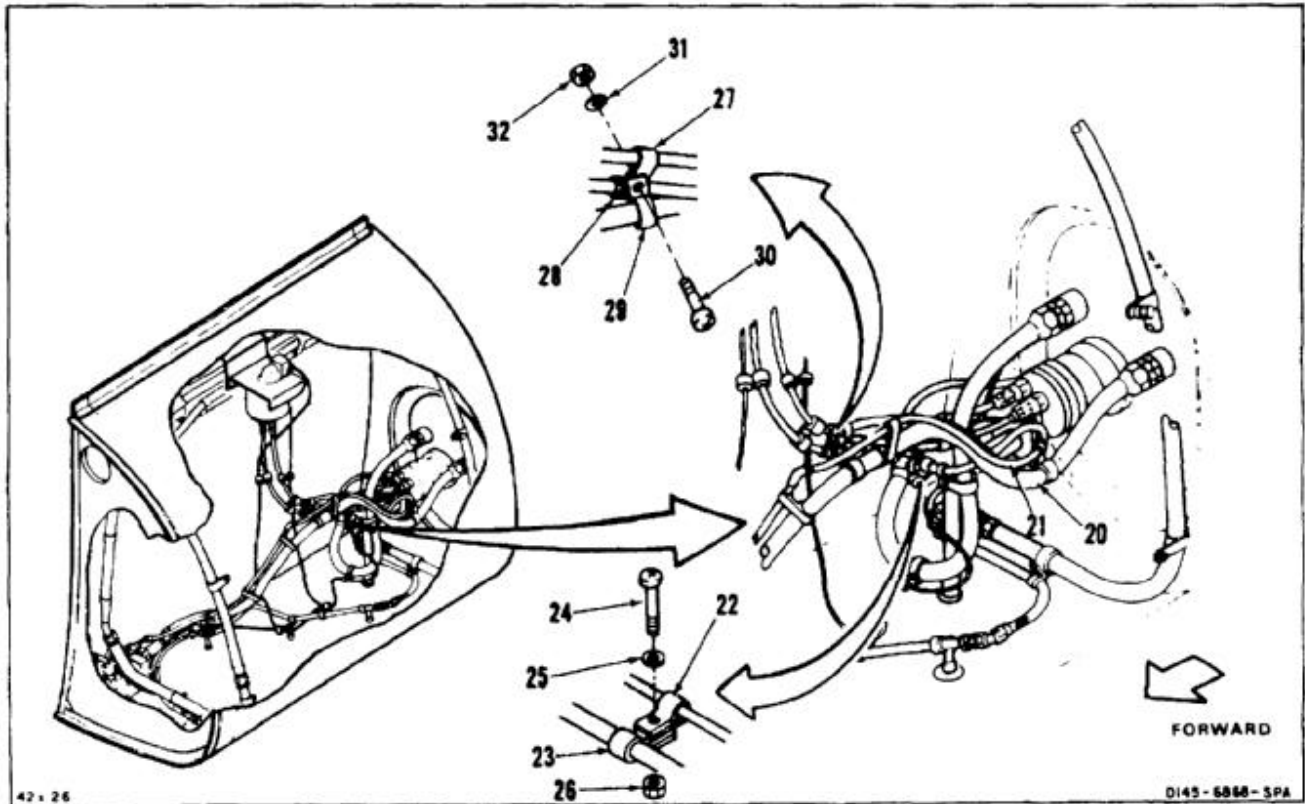

11. Connect two hose connectors (33) and hose connector (34). Remove tags.
12. Position screw (35) through washer (36), two hose clamps (37), spacer (38), hose clamp (39), electrical cable clamp (40) and spacer (41). Install screw (35) in fuel cell mounting plate (42).
13. Remove screw (43) and washer (44). Position cable clamp (45). Install washer and screw.
14. Remove four screws (46 and 47) and washers (48 and 49). Remove tags and position four electrical terminals (50 and 51). Install washers and screws.

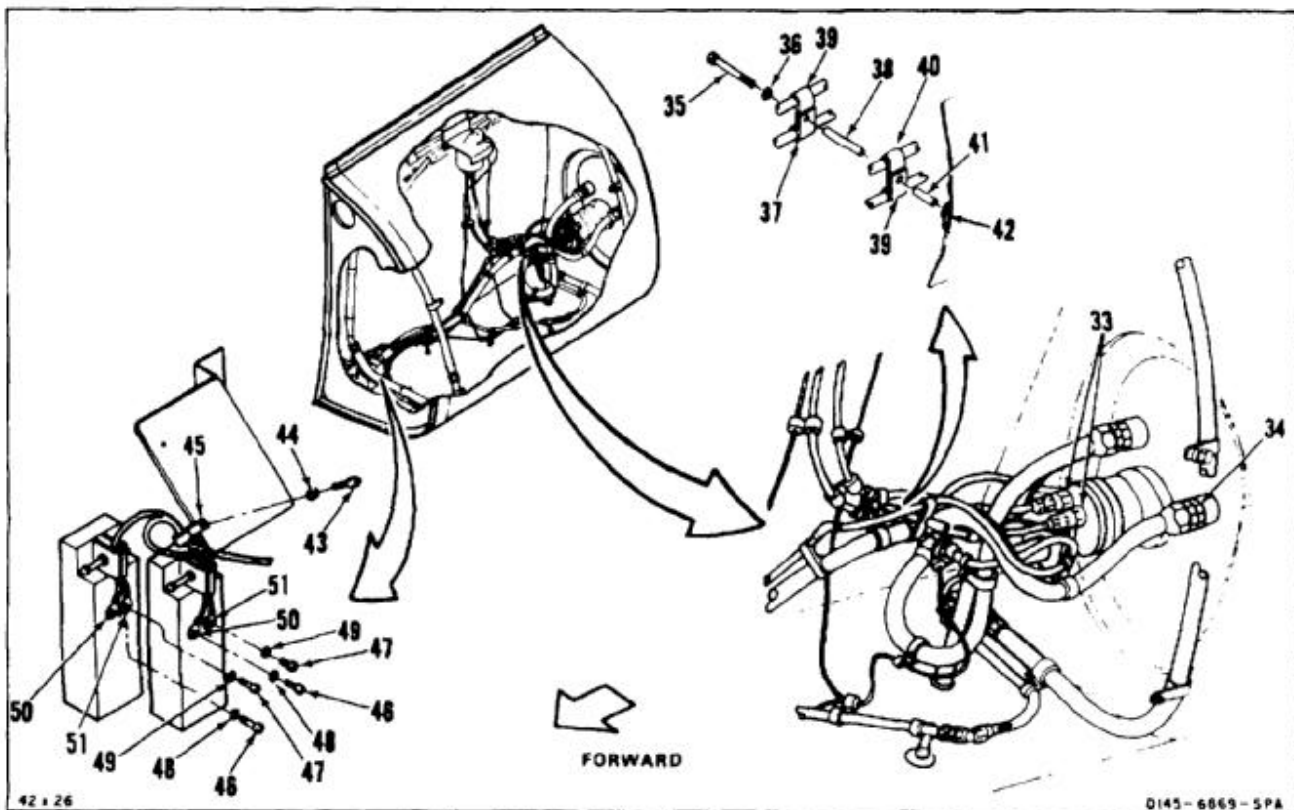

15. Remove barrier material and tape from three holes in tank (52). Clean tape residue from tank. Use dry cleaning solvent (E162) and cloths (E135). Wear goggles to protect eyes. Wear gloves (E186).
16. Have helper, from inside tank, push three receptacles (53) through holes in tank (52). Install three locknuts (54) on receptacles. Install lockwire (E227).
17. Connect three electrical connectors (55). Install lockwire (E227).

INSPECT**FOLLOW-ON MAINTENANCE:**

- Install fuel tank boost pump (Task 10-70).
- Perform vent system pressure test (Task 10-117).
- Raise and install forward fuel tank (Task 10-26).
- Install fuel quantity transmitter (Task 8-82).
- Test forward fuel tank (Task 10-27).
- Perform vent system flow test (Task 10-118).
- Perform test of pressure refueling system (Task 10-119) and fuel feed system (Task 10-120).
- Refuel helicopter (Task 1-51).
- Bleed fuel system (Task 10-121).
- Perform operational check of appropriate fuel system (TM 55-1520-240-T).

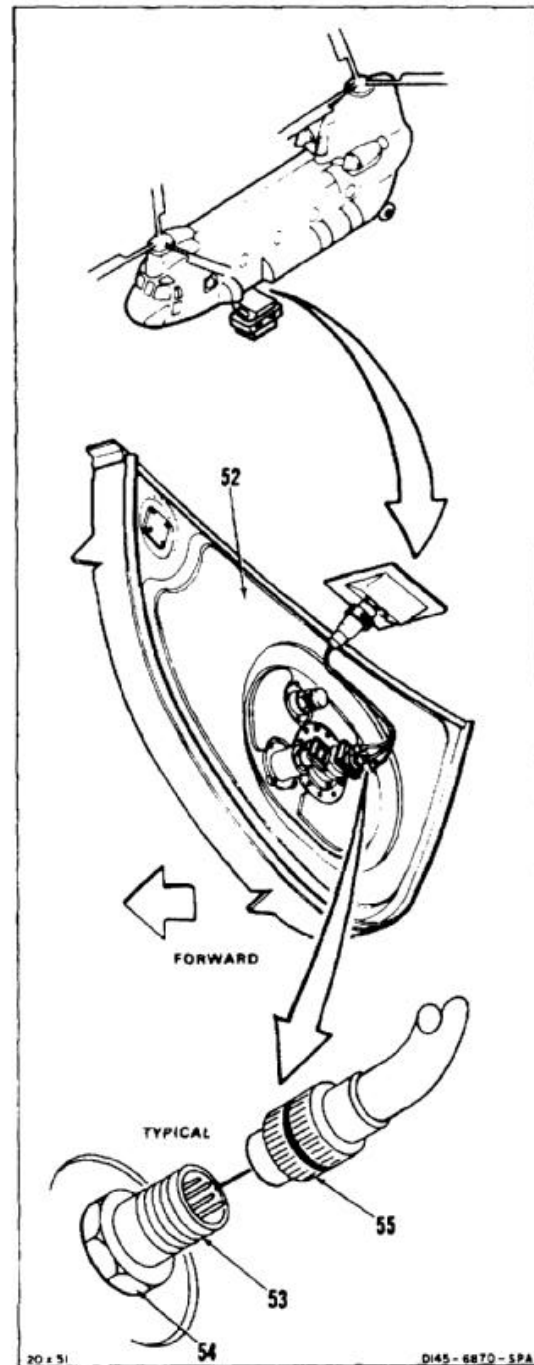

END OF TASK

INITIAL SETUP

Applicable Configurations:

All

Tools:

Aircraft Mechanic's Tool Kit, NSN 5180-00-323-4692
 Wrench, Open End, 1-1/8 Inch
 Wrench, Open End, 1-1/2 Inch

Materials:

Barrier Material (E80)
 Tape (E388)

Personnel Required:

Medium Helicopter Repairer

Equipment Condition:

Battery Disconnected (Task 1-39)
 Electrical Power Off
 Helicopter Grounded (Task 1-29)
 Defuel Forward Fuel Tank (Task 10-34 or 10-35)
 Forward Fuel Tank Lowered on Hinges (Task 10-23)

General Safety Instructions:**WARNING**

All regulations and instructions
 for handling fuels shall be strictly
 observed.

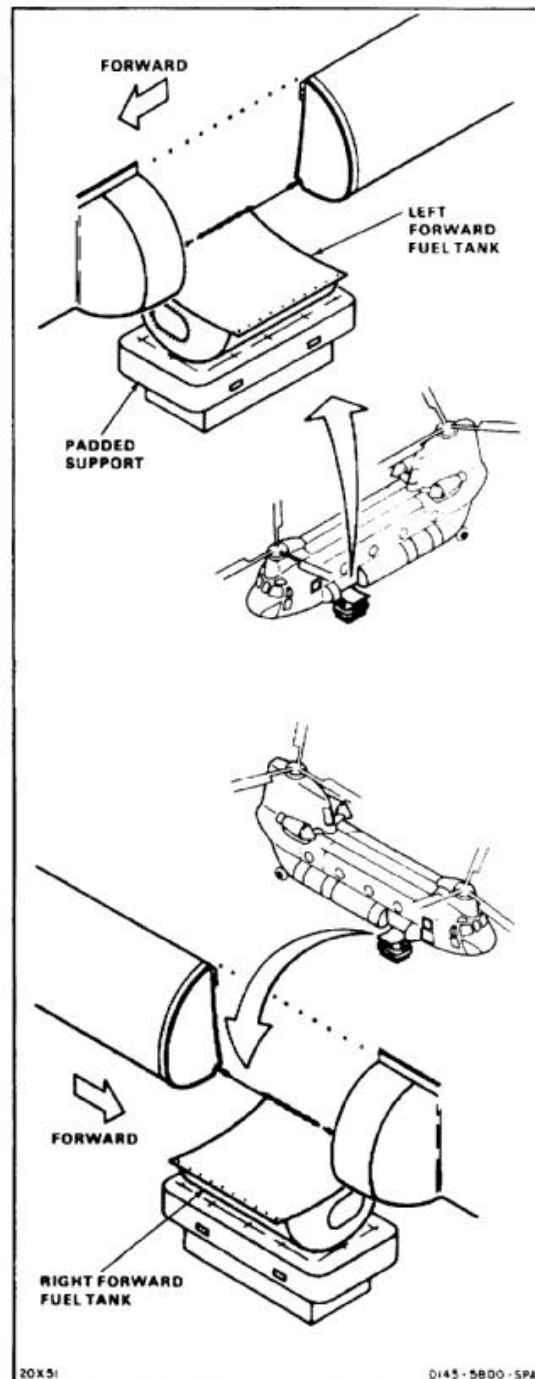

NOTE

Procedure is same to remove boost pump from No. 1 or No. 2 fuel system forward fuel tank. Removal of No. 1 (left) boost pump is shown here.

REMOVE FORWARD ACCESS DOOR

1. Remove 30 bolts (1) and washers (2).
2. Remove door (3) and gasket (4).

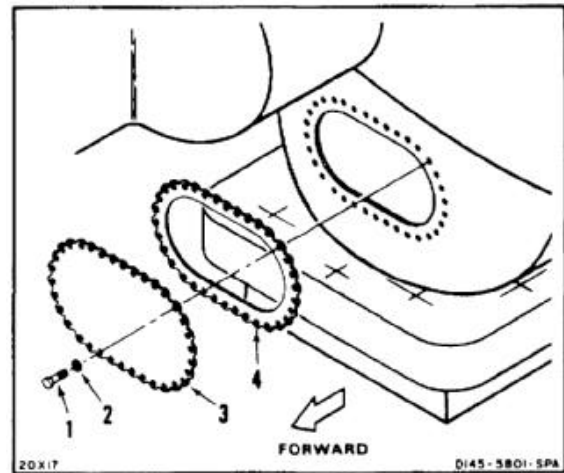
**REMOVE BOOST PUMP**

Do not puncture or scratch lining of fuel tank. If lining is broken, fuel penetrates and activates self-sealing layer. Activated layers swell and trap fuel. Activated green spongy material also contaminates fuel system. This makes it necessary to replace fuel tank and flush fuel system.

3. Remove lockwire and disconnect electric connector (5) from boost pump (6).
4. Disconnect hose (7) from boost pump (6). Cap boost pump. Plug hose.
5. Remove four bolts (8) and washers (9).
6. Maneuver boost pump (6) from pump bracket (10) and remove pump.
7. Cover access hole in tank (11) with barrier material (E80) and tape (E388).

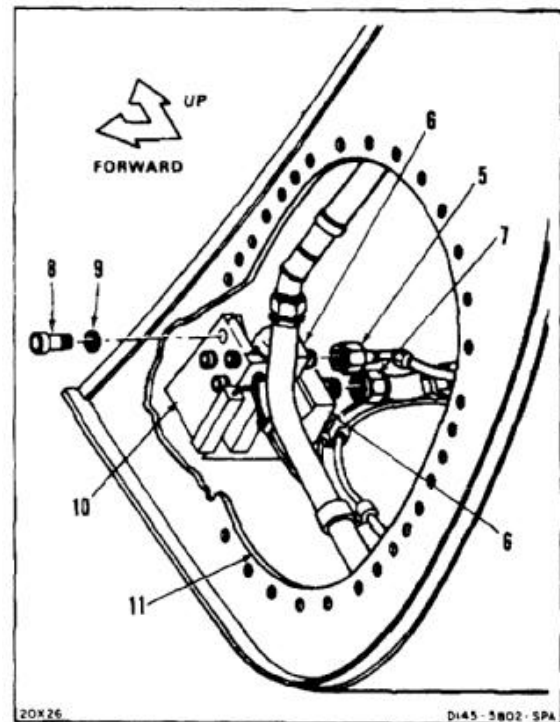
**FOLLOW-ON MAINTENANCE:**

None

END OF TASK

INITIAL SETUP

Applicable Configurations:

All

Tools:

Aircraft Mechanic's Tool Kit, NSN 5180-00-323-4692
 Torque Wrench, 30 to 150 Inch-Pounds
 Torque Wrench, 700 to 1600 Inch-Pounds
 Wrench, Open End, 1-1/8 Inch
 Wrench, Open End, 1-1/2 Inch

Materials:

Lockwire (E233)
 Cloths (E135)
 Dry Cleaning Solvent (E162)
 Gloves (E186)

Parts:

Gasket

Personnel Required:

Medium Helicopter Repairer
 Inspector

References:

Task 10-117
 TM 55-1520-240-23P

WARNING

All regulations and instructions
 for handling fuels shall be strictly
 observed.

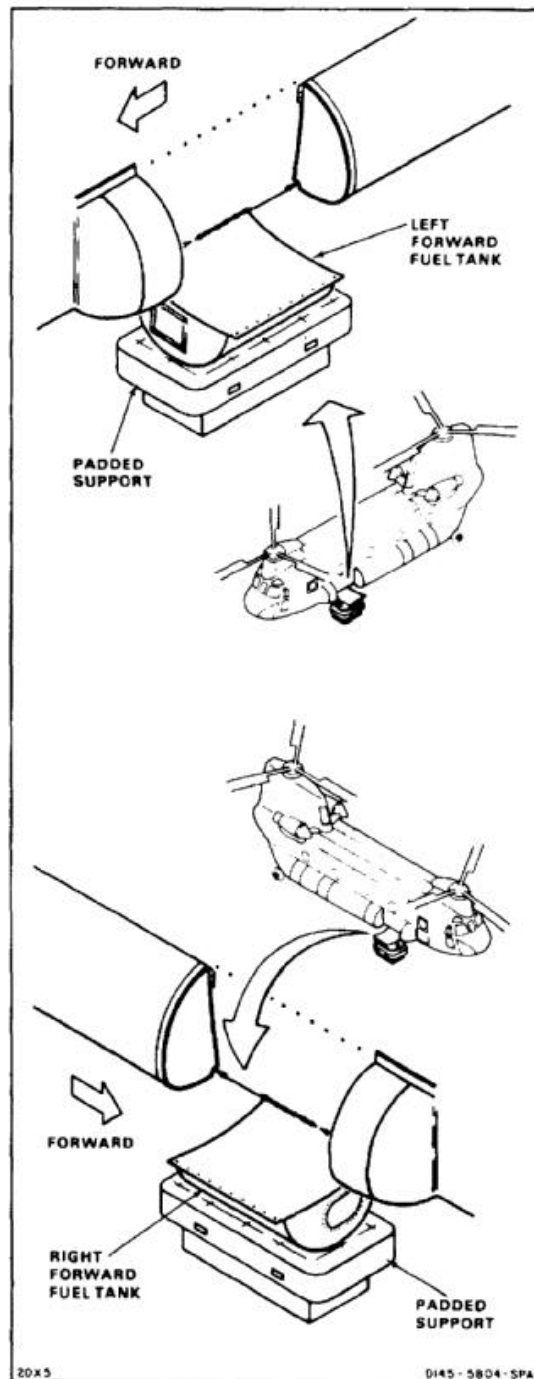

WARNING

Dry cleaning solvent (E162) is flammable and toxic. It can irritate skin and cause burns. Use only in well-ventilated area, away from heat and open flame. In case of contact, immediately flush skin or eyes with water for at least **15 minutes**. Get medical attention for eyes.

NOTE

Procedure is same to install boost pump in No. 1 or No. 2 fuel system forward fuel tank. Installation of No. 1 (left) boost pump is shown here.

INSTALL BOOST PUMP

1. Remove barrier paper and tape covering access hole in tank (1). Clean tape residue from face of tank. Use dry cleaning solvent (E162) and cloths (E135). Wear goggles to protect eyes. Wear gloves (E186).

CAUTION

Do not puncture or scratch lining of fuel tank. If lining is broken, fuel penetrates and activates self-sealing layers. Activated layers swell and trap fuel. Activated green spongy material also contaminates fuel system. This makes it necessary to replace fuel tank and flush fuel system.

2. Position boost pump (2) on pump bracket (3). Install four bolts (4) and washers (5).
3. Remove plug from hose (6) and cap from boost pump (2). Connect hose to boost pump. Torque how connector to **1125 inch-pounds**.
4. Connect electrical connector (7) to pump (2). Lockwire connector to pump. Use lockwire (E233).

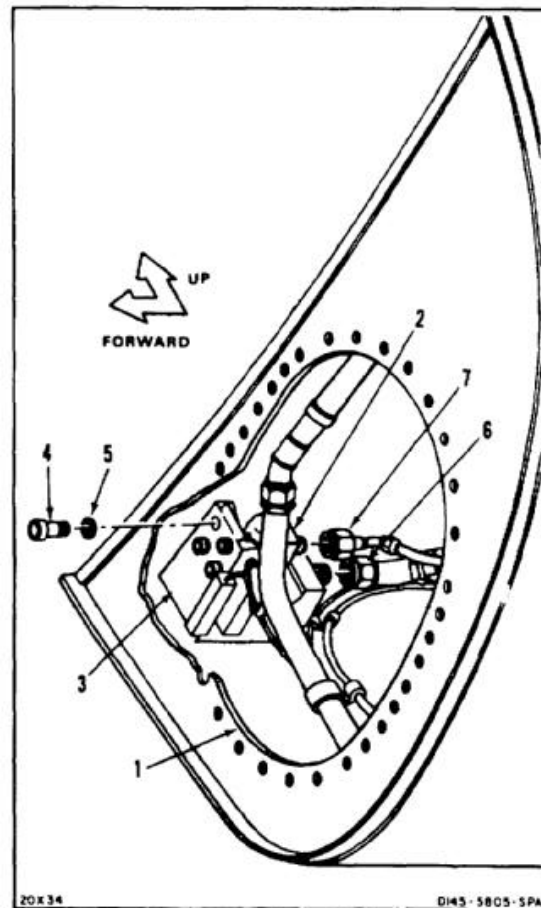
INSPECT

INSTALL ACCESS DOOR

5. Perform vent system pressure test (Task 10-117).
6. Position gasket (8) and door (9). Install 30 washers (10) and bolts (11). Torque bolts to **70 inch-pounds**.

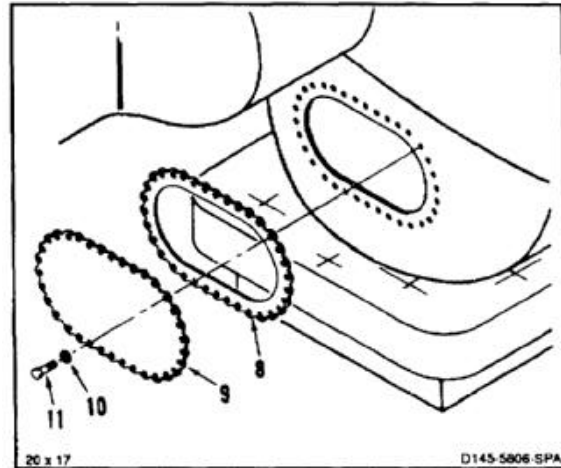
**FOLLOW-ON MAINTENANCE:**

- Install forward fuel tank (Task 10-26).
- Perform test of pressure refueling system (Task 10-119) and fuel feed system (Task 10-120).
- Refuel helicopter (Task 1-51).
- Bleed fuel system (Task 10-121).
- Perform operational check of appropriate fuel system (TM 55-1520-240-T).

END OF TASK

10-71 REMOVE FORWARD FUEL TANK FUEL LEVEL SHUTOFF VALVE**10-71****INITIAL SETUP****Applicable Configurations:**

All

Tools:

Aircraft Mechanic's Tool Kit, NSN 5180-00-323-4692
 Grounded Container, 2 Quart or Equivalent

Materials:

Cloths (E135)
 Barrier Material (E80)
 Tape (E388)

Personnel Required:

Medium Helicopter Repairer

Equipment Condition:

Battery Disconnected (Task 1-39)
 Electrical Power Off
 Helicopter Grounded (Task 1-29)
 Forward Landing Gear Access Panel On Affected
 Side of Helicopter Opened (Task 2-2)
 All Tanks on Affected Side of Helicopter Defueled
 and Both Crossover Valves Closed (Task 10-34
 or 10-35)

General Safety Instructions:**WARNING**

All regulations and instruction
 for handling fuels shall be strictly
 observed.

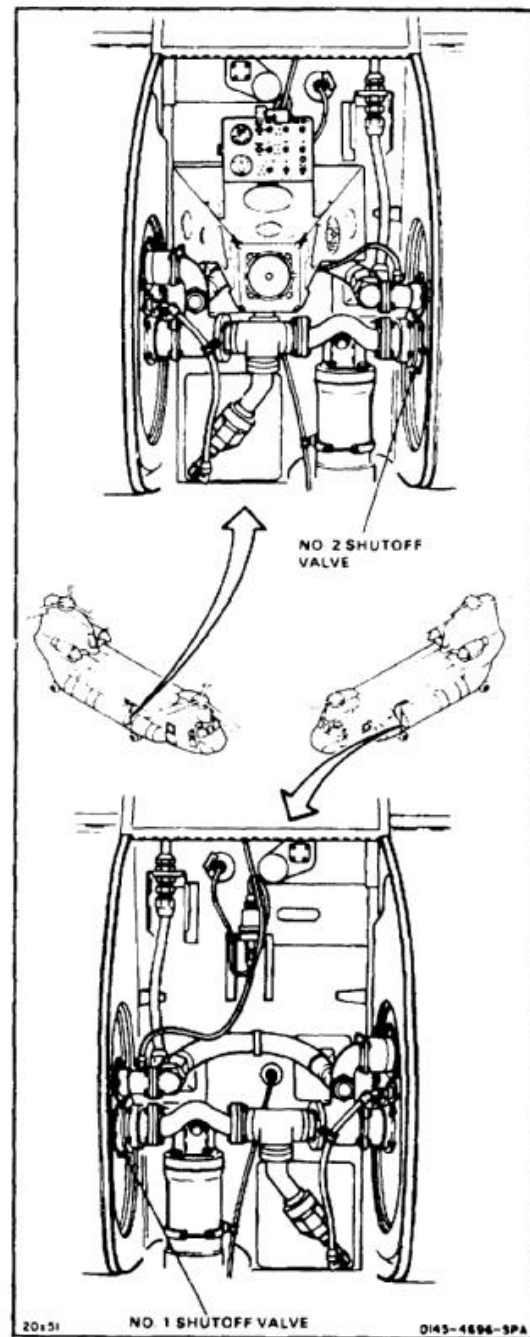

NOTE

Procedure is same to remove fuel level shutoff valve in No. 1 or No. 2 fuel system. Removal of No. 2 (right side) shutoff valve is shown here.

NOTE

Index number 4 is not used.

1. Remove eight nuts (1), washers (2), and bolts (3).
2. Slide adapter (5) aft into fitting (6). Catch spilled fuel in grounded container.
3. Remove gaskets (7 and 8) and tube (9).
4. Cover hole in adapter (5). Use barrier material (E80) and tape (E388).

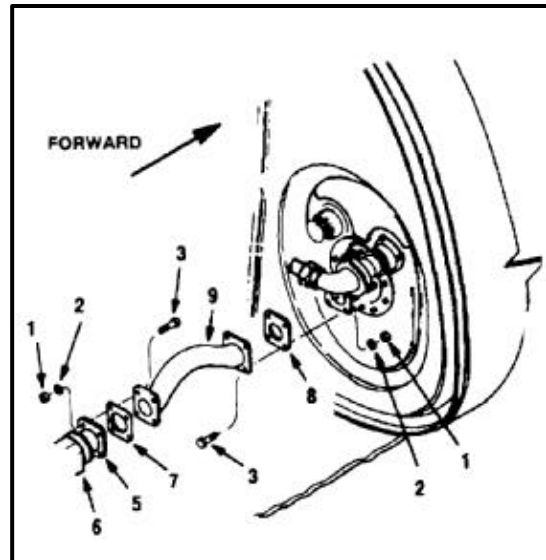

5. Remove 10 bolts (10) and washers (11).
6. Withdraw shutoff valve (12) from tank (13) for access to two hose connections (14). Disconnect hose connections.
7. Maneuver shutoff valve (12) from tank (13). Cover hole in tank. Use barrier material (E80) and tape (E388).
8. Remove packing (15) from flange of valve (12).

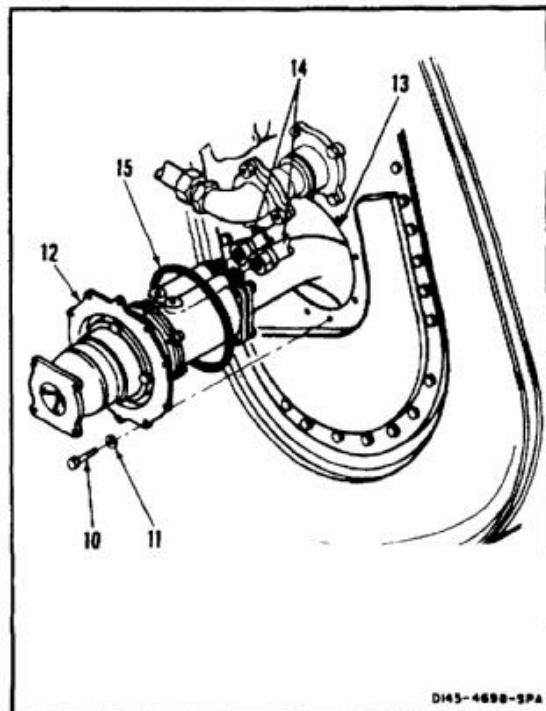

10-71 REMOVE FORWARD FUEL TANK FUEL LEVEL SHUTOFF VALVE (Continued)**10-71**

9. Remove four bolts (16) and washers (17). Remove fitting (18) and packing (19) from valve (12).
10. Remove four bolts (20), washers (21), and nuts (22). Remove tube (23).
11. Cleanup spilled fuel. Use cloths (E135).

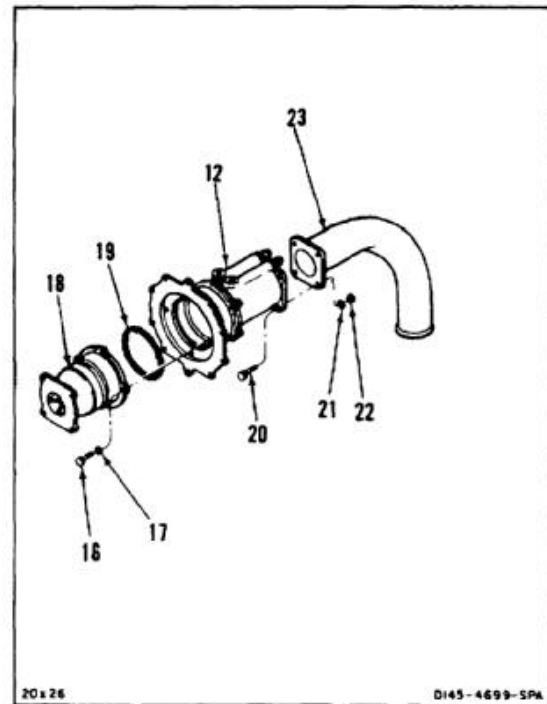
***FOLLOW-ON MAINTENANCE:***

None

END OF TASK

INITIAL SETUP

Applicable Configurations:

All

Tools:

Aircraft Mechanic's Tool Kit, NSN 5180-00-323-4692

Materials:

Dry Cleaning Solvent (E162)
Cloths (E135)
Gloves (E184.1)

Parts:

Packings
Gaskets

Personnel Required:

Medium Helicopter Repairer
Inspector

References:

TM 55-1520-240-23P

General Safety Instructions:**WARNING**

All regulations and instructions for handling fuels shall be strictly observed.

WARNING

Dry cleaning solvent (E162) is flammable and toxic. It can irritate skin and cause burns. Use only in well-ventilated area, away from heat and open flame. In case of contact, immediately flush skin or eyes with water for at least **15 minutes**. Get medical attention for eyes.

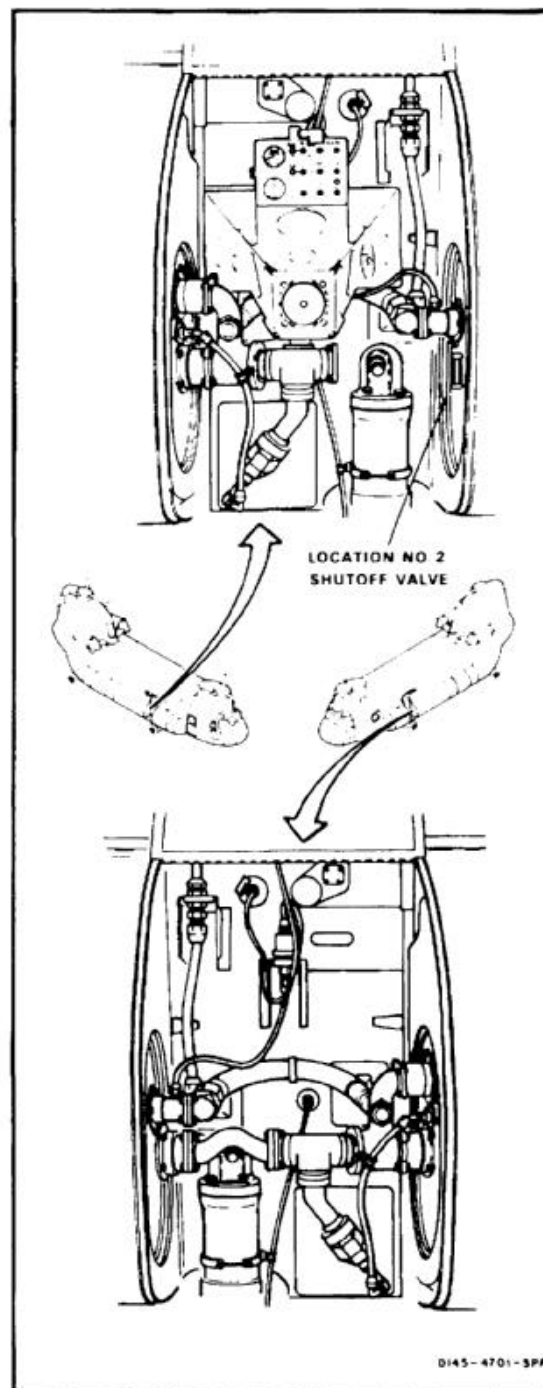

NOTE

Procedure is same to install fuel level shutoff valve in No. 1 or No. 2 fuel system. Installation of No. 2 (right) shutoff valve is shown here.

1. Position tube (1) on shutoff valve (2). Make sure two hose connections (3) are at top, and tube points down. Install four bolts (4), washers (5), and nuts (6).
2. Position packing (7) on fitting (8). Position fitting (8) on valve (2). Install four bolts (9) and washers (10).

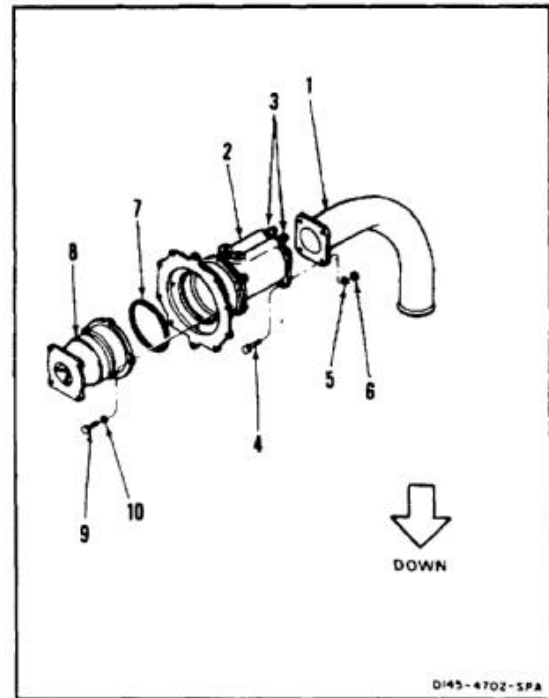

3. Install packing (11) on flange of valve (2).
4. Remove barrier material and tape from hole in tank (12). Clean tape residue from tank. Use cloth (E135) damp with dry cleaning solvent (E162). Wear gloves (E184.1).
5. Maneuver fuel valve (2) through hole in tank (12) with tube (1) pointing down. Connect two hoses (13) to valve connections (3).
6. Position flange of valve (2) against tank (12) with tube (1) pointing down. Install 10 bolts (14) and washers (15).

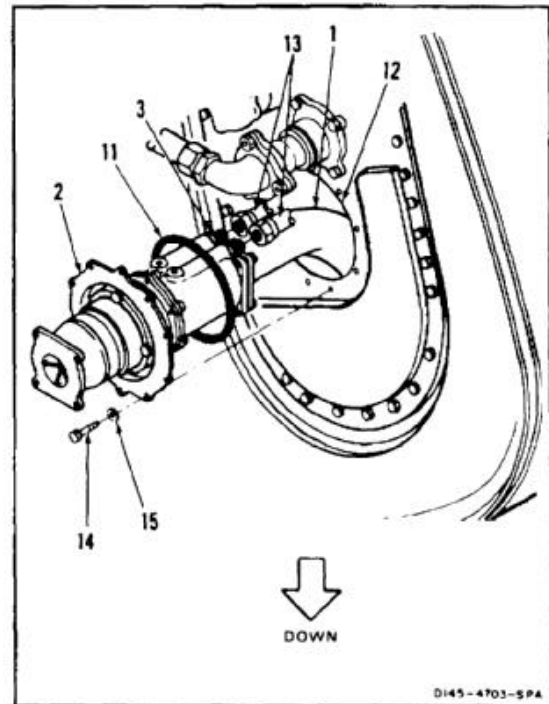

NOTE

Index number 19 is not used.

7. Remove barrier material and tape from adapter (16). Clean tape residue from adapter flange. Use dry cleaning solvent (E162) and cloths (E135). Wear gloves (E184.1).

NOTE

Tube (18) is not symmetrical. Make sure that the upper nut on the landing gear mount remains accessible when installing the tube.

NOTE

Gasket at aft end of tube has larger center hole than gasket at forward end of tube.

8. Position gasket (17) and tube (18) on valve (2). Install four bolts (20), washers (21) and nuts (22).
9. Position gasket (23) on tube (18). Slide adapter (24) forward. Install four bolts (25), washers (26), and nuts (27).

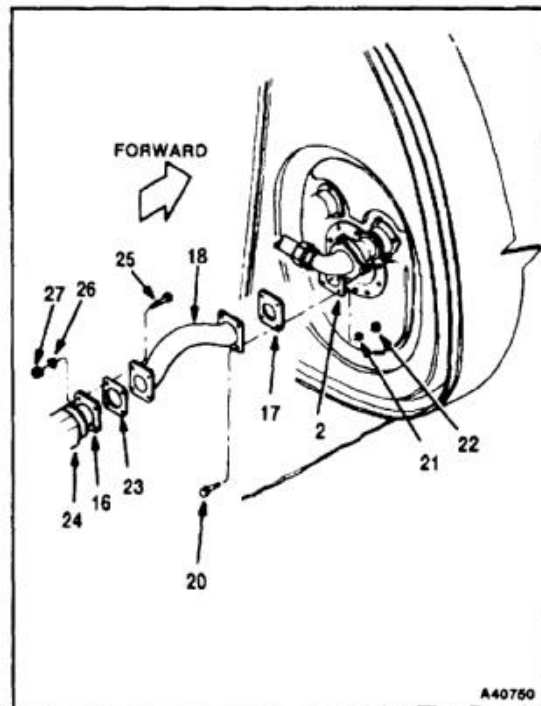
**INSPECT****FOLLOW-ON MAINTENANCE:**

- Perform vent system flow test (Task 10-118).
- Perform pressure refueling system test (Task 10-119).
- Test forward tank after installation (Task 10-27).
- Refuel helicopter (Task 1-51).
- Check for leaks (Task 10-4).
- Bleed fuel system (Task 10-121).
- Perform operational check of fuel system (TM 55-1520-240-T).
- Close forward landing gear access panel (Task 2-2).

END OF TASK

10-72.1 REMOVE LOW FUEL LEVEL SENSOR

10-72.1

INITIAL SETUP

Applicable Configurations:

All

Tools:

Aircraft Mechanic's Tool Kit, NSN 5180-00-323-4692

Materials:

None

Personnel Required:

Medium Helicopter Repairer

Equipment Condition:

- Battery Disconnected (Task 1-39)
- Electrical Power Off
- Helicopter Grounded (Task 1-29)
- Forward or Aft Tank Defueled (Task 10-34 or 10-35)
- Forward Fuel Tank Lowered on Hinges (Task 10-23) and Forward Fuel Tank Forward Access Door Removed (Task 10-69), or Aft Fuel Tank Forward Access Door Removed (Task 10-79)

General Safety Instructions:

WARNING

All regulations and instructions for handling fuel shall be strictly observed.

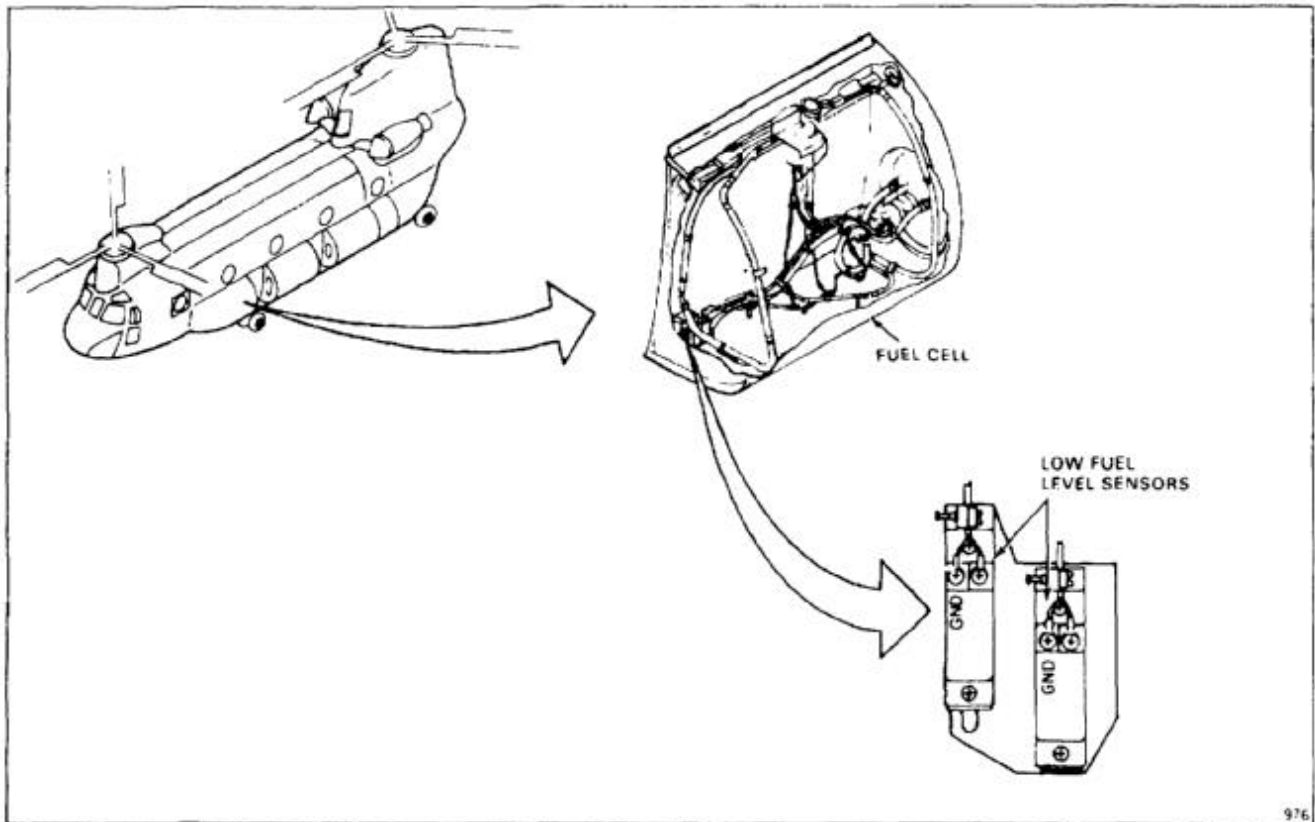

NOTE

Procedure is same to remove No. 1 or No. 2 forward or aft fuel tank low fuel level sensors. No. 1 (left) forward sensors are shown here.

1. Remove four screws (1) and washers (2).
2. Remove four screws (3) and washers (4). Loosen two screws (5). Remove wires (6, 7, 8, and 9) from two sensors (10). Remove plate (11) and sensors from bracket (11.1).
3. Remove four screws (12), washers (13 and 14), two plate supports (15), and four nuts (16). Remove sensors (10).

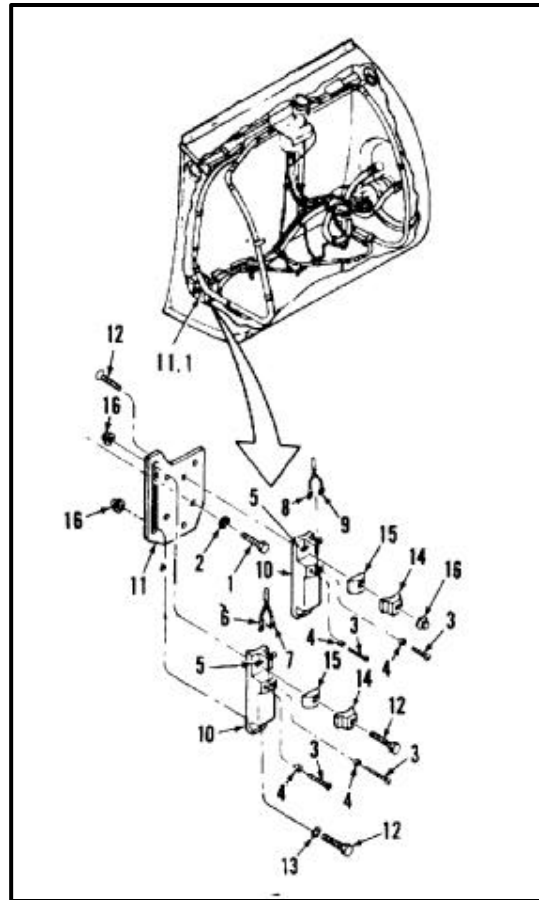
**FOLLOW-ON MAINTENANCE:**

None

END OF TASK

10-354

10-72.2 INSTALL LOW FUEL LEVEL SENSOR

10-72.2

INITIAL SETUP

Applicable Configurations:

All

Tools:

Aircraft Mechanic's Tool Kit, NSN 51 80-00-323-4692

Materials:

None

Personnel Required:

Medium Helicopter Repairer
Inspector

General Safety Instructions:

WARNING

All regulations and instructions on handling fuels shall be strictly observed.

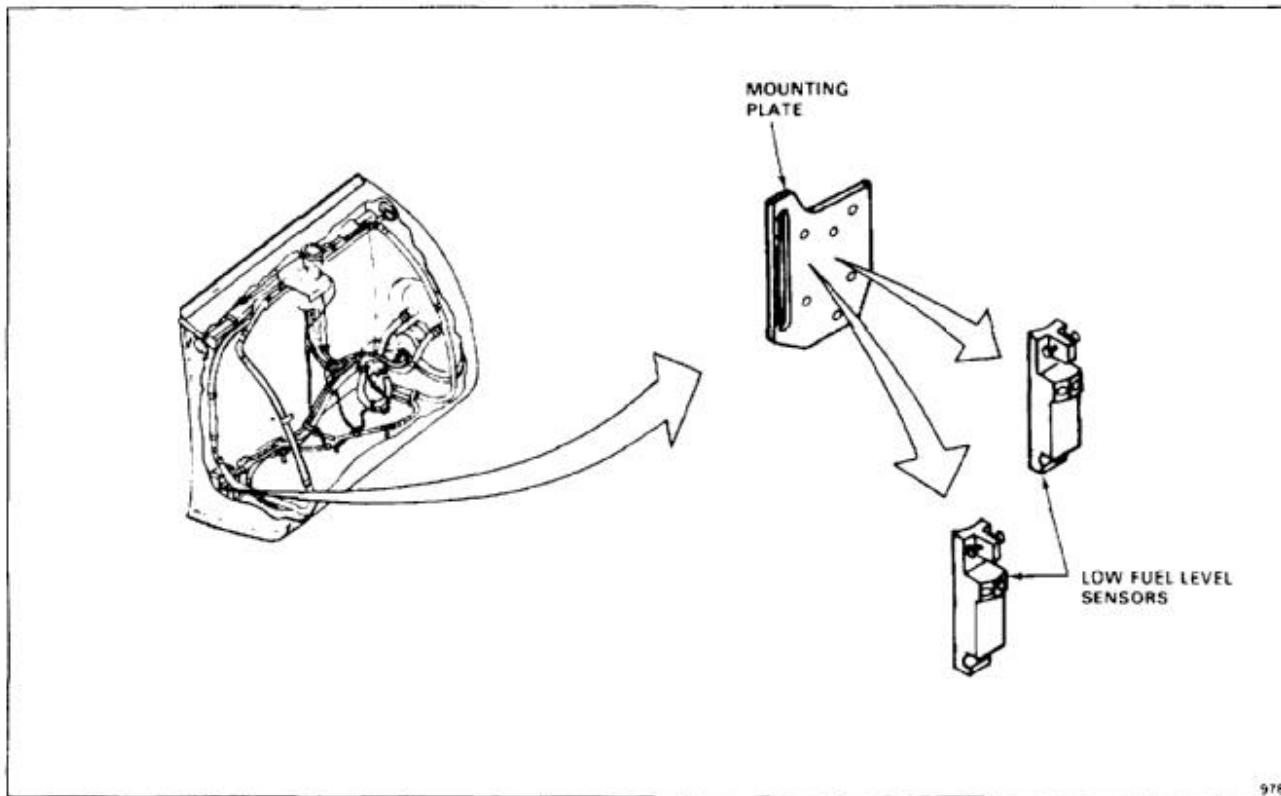

978

NOTE

Procedure is same to install No. 1 or No. 2 forward or aft fuel tank low fuel level sensors. No. 1 (left) forward sensors are shown here.

1. Position sensor (1) over slot (2) on mounting plate (3). Install two screws (4), with heads facing out, washer (5), plate support (6), washer (7), and two nuts (8) as shown.
2. Position lower sensor (9) on mounting plate (3). Install two screws (4), with heads facing in, washer (5), plate support (6), washer (7), and two nuts (8) as shown.

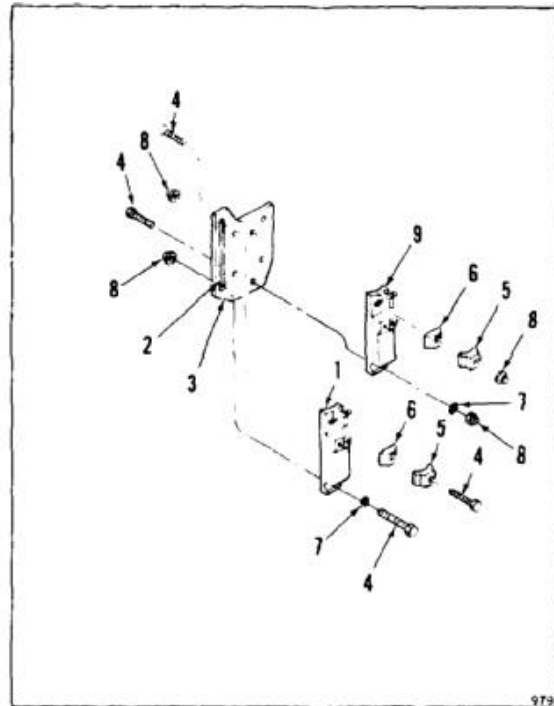

10-72.2 INSTALL LOW FUEL LEVEL SENSOR (Continued)

10-72.2

3. Connect wires (10, 11, 12, and 13) as follows:
 - a. Connect yellow wire (10) to GND on sensor (1) over slot (14). Use screw (15) and washer (16).
 - b. Connect red wire (11) to unmarked side of sensor (1) over slot (14). Use screw (15) and washer (16).
 - c. Connect green wire (12) to GND on lower sensor (9). Use screw (15) and washer (16).
 - d. Connect black wire (13) to unmarked side of lower sensor (9). Use screw (15) and washer (16).
4. Loosen two screws (17). Position wires (10 and 11) and (12 and 13) in clamps (18). Tighten screws.
5. Position plate (3) on bracket (19). Install plate with four screws (20) and washers (21).

INSPECT**FOLLOW-ON MAINTENANCE:**

Install forward fuel tank forward access door (Task 10-70) and raise and install forward fuel tank (Task 10-26), or install aft fuel tank forward access door (Task 10-80).

Refuel helicopter (Task 1-51).

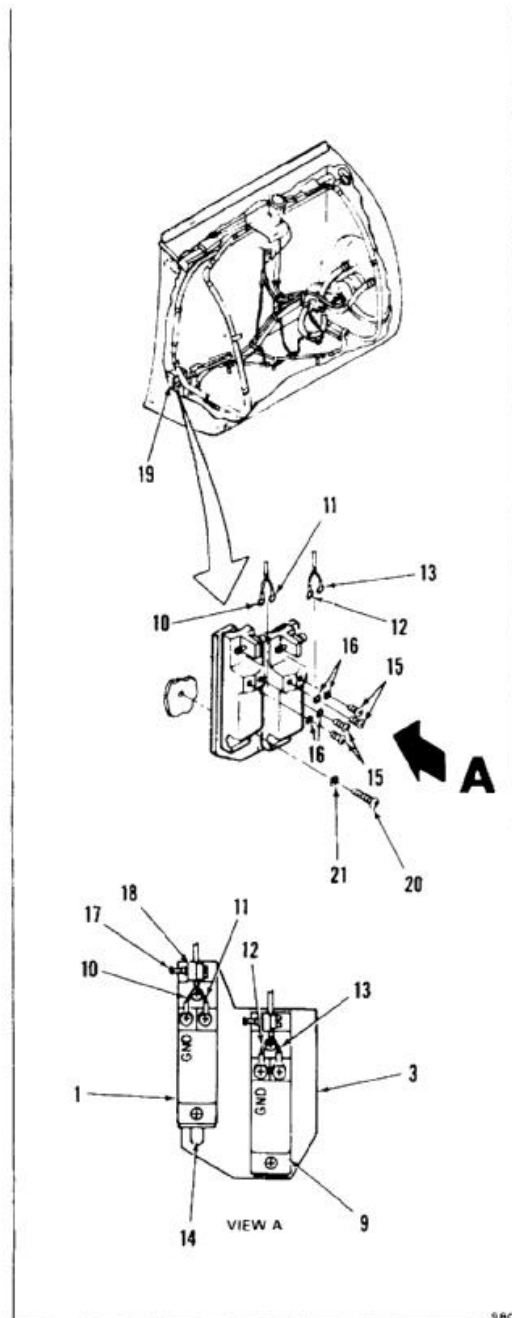

END OF TASK

INITIAL SETUP

Applicable Configurations:

All

Tools:

Aircraft Mechanic's Tool Kit, NSN 5180-00-323-4692

Materials:

Barrier Material (E80)
Tape (E388)

Personnel Required:

Medium Helicopter Repairer

Equipment Condition:

- Battery Disconnected (Task 1-39)
- Electrical Power Off
- Helicopter Grounded (Task 1-29)
- Helicopter Defueled (Task 10-34 or 10-35)
- Forward Landing Gear Access Panel Removed (Task 2-178 or 2-180)
- Fuel Tank Lowered On Hinges (Task 10-23)

General Safety Instructions:

WARNING

All regulations and instructions for handling fuels shall be strictly observed.

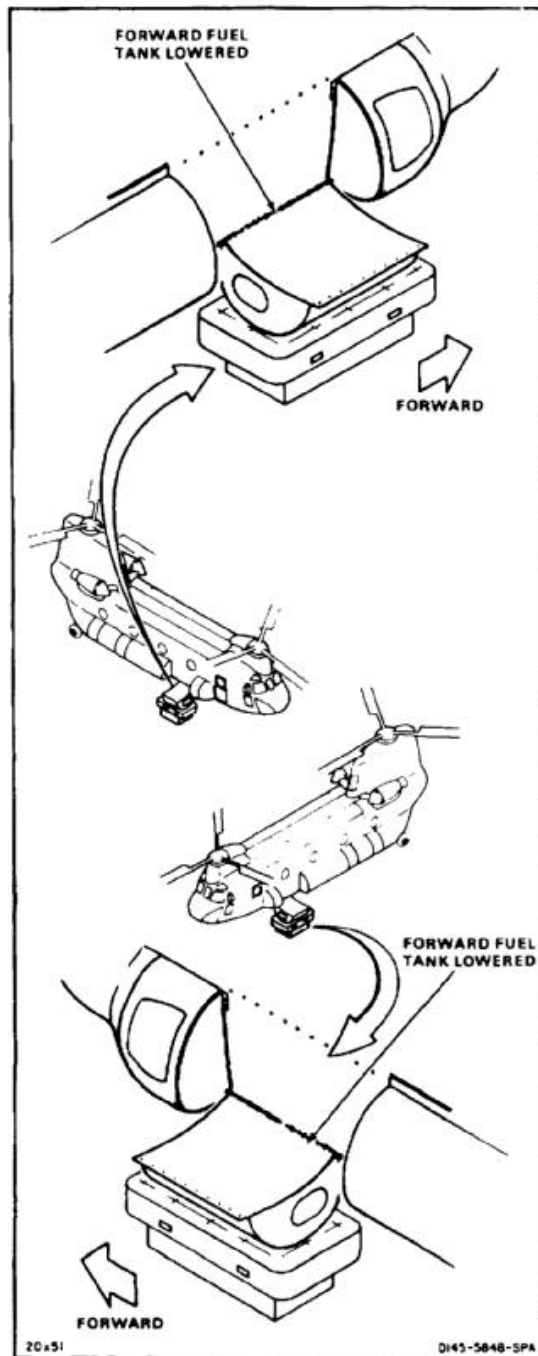

NOTE

Procedure is same to remove vent valve from No. 1 or No. 2 forward fuel tank. Removal of No. 2 (right) vent valve is shown here.

1. Remove 30 bolts (1) and washers (2).
2. Remove door (3) and gasket (4) from forward access hole (5).

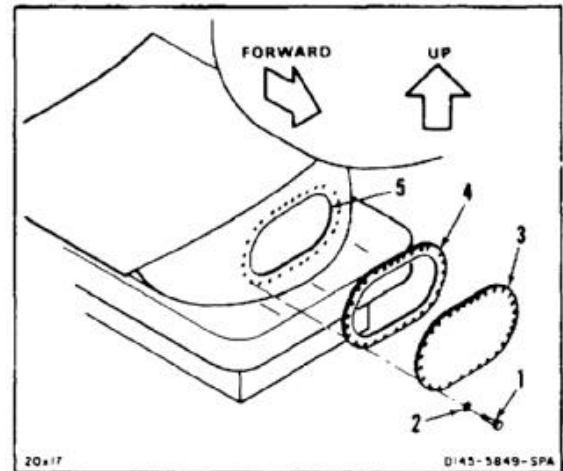

Do not puncture or scratch lining of fuel tank. If lining is broken, fuel penetrates and activates self-sealing layers. Activated layers swell and trap fuel. Activated green spongy material also contaminates fuel system. This makes it necessary to replace fuel tank and flush fuel system.

3. Working through forward access hole (5), disconnect hose (6) from valve (7). Plug hose.
4. Disconnect tube (8) from valve (7).
5. Remove four bolts (9) and washers (10).
6. Remove valve (7) and adapter (11) from tank (12) as a unit.

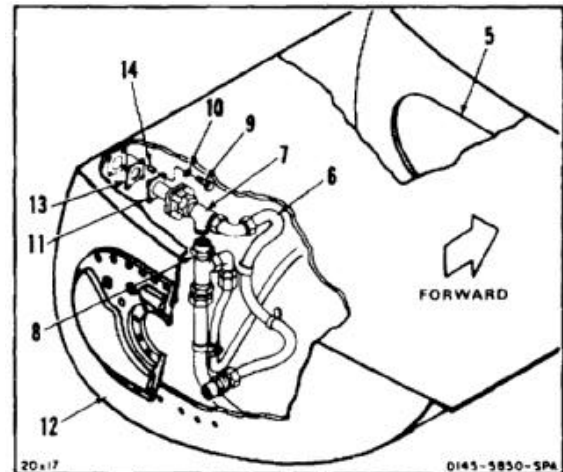
**NOTE**

Four different types of forward fuel cells are used on the helicopter. Each is interchangeable, but has a different assembly between valve adapter and cell. Goodyear cells have four bushings. FPT cells have an adapter plate and Uniroyal cells have nothing between adapter and cell.

7. Remove shim plate (13) or four bushings (14) from tank (12).
8. Cover access hole (14) in tank (12). Use barrier material (E80) and tape (E388).

FOLLOW-ON MAINTENANCE:

None

END OF TASK

INITIAL SETUP

Applicable Configurations:

All

Tools:

Aircraft Mechanic's Tool Kit, NSN 5180-00-323-4692

Materials:

- Dry Cleaning Solvent (E162)
- Cloths (E135)
- Gloves (E186)

Parts:

Gasket

Personnel Required:

- Medium Helicopter Repairer
- Inspector

References:

- Task 10-117
- TM 55-1520-240-23P

General Safety Instructions:

WARNING

All regulations and instructions for handling fuels shall be strictly observed.

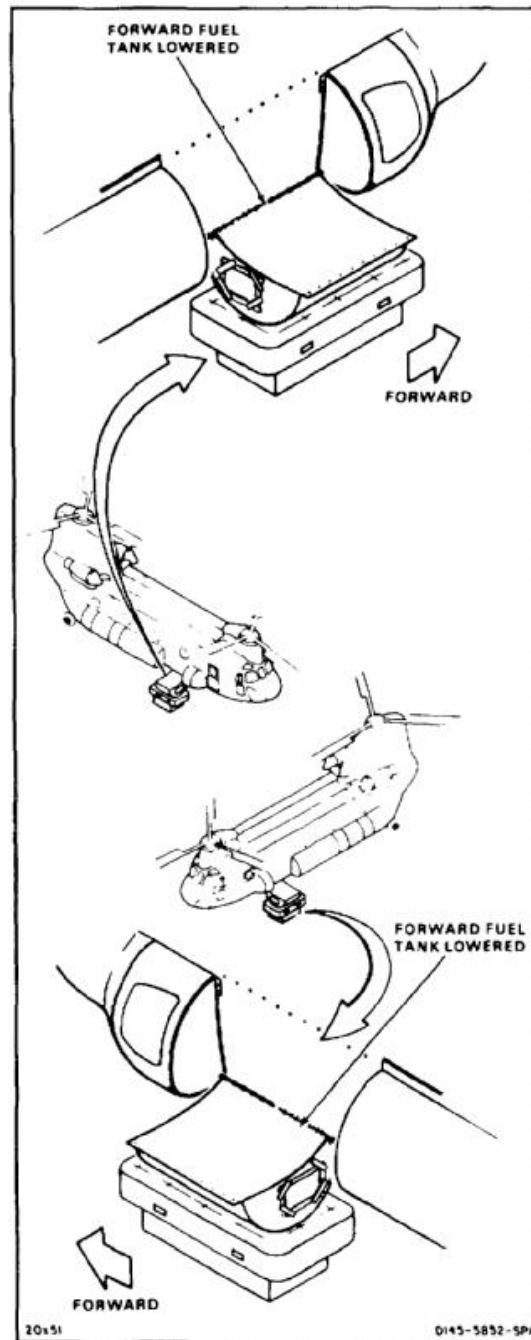

WARNING

Dry cleaning solvent (E162) is flammable and toxic. It can irritate skin and cause burns. Use only in well-ventilated area, away from heat and open flame. In case of contact, immediately flush skin or eyes with water for at least **15 minutes**. Get medical attention for eyes.

NOTE

Procedure is same to install vent valve on No. 1 or No. 2 forward fuel tank. Installation of No. 2 (right) vent valve is shown here.

1. Remove barrier material and tape covering forward hole (1) in tank (2). Remove tape residue from tank. Use dry cleaning solvent (E162) and cloths (E135). Wear goggles to protect eyes. Wear gloves (E186).

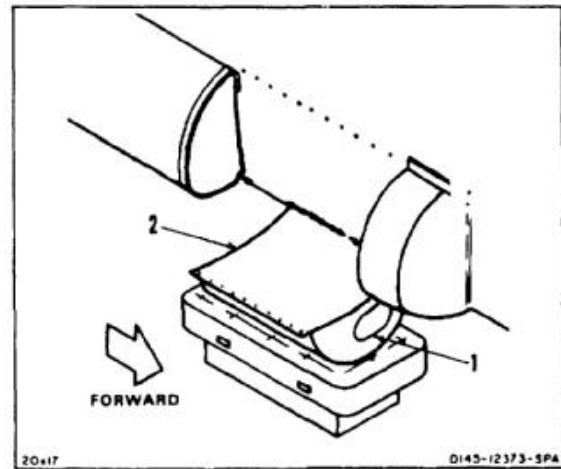

CAUTION

Do not puncture or scratch lining of fuel tank. If lining is broken, fuel penetrates and activates self-sealing layers. Activated layers swell and trap fuel. Activated green spongy material also contaminates fuel system. This makes it necessary to replace fuel tank and flush fuel system.

NOTE

Four different types of forward fuel cells are used on the helicopter. Each is interchangeable, but has a different assembly between valve adapter and cell. Goodyear cells have four bushings, FPT cells have an adapter plate and Uniroyal cells have nothing between adapter and cell.

2. Working through forward access hole (1), position shim plate (3), or four bushings (4) as required, adapter (5) and valve (6) with port (7) down, over drain valve (8), on floor of tank (2).
3. Install four washers (9) and bolts (10).
4. Connect tube (11) to port (7) of valve (6).
5. Remove plug from hose (12). Connect hose to valve (6).

INSPECT

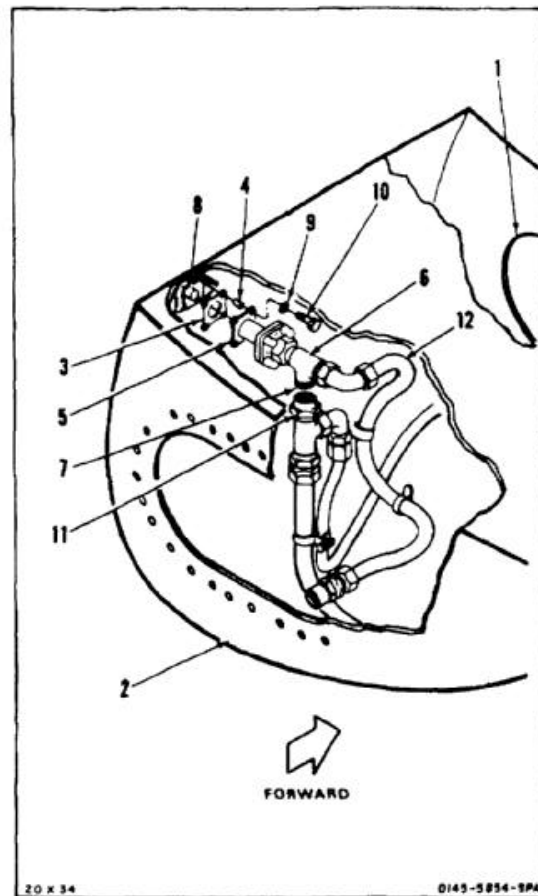

10-74 INSTALL FORWARD FUEL TANK VENT VALVE (Continued)**10-74**

6. Perform vent system pressure test (Task 10-117).
7. Position gasket (13) and door (14).
8. Install 30 washers (15) and bolts (16). Torque bolts (16) to **70 inch-pounds**.

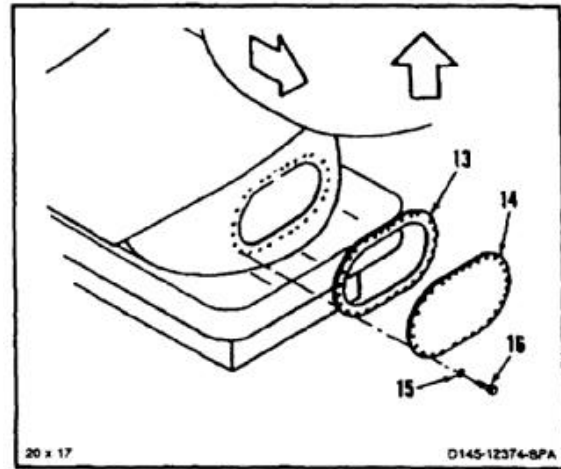
**INSPECT****FOLLOW-ON MAINTENANCE:**

- Raise and install fuel tank (Task 10-26).
- Test forward fuel tank (Task 10-27).
- Perform vent system flow test (Task 10-118).
- Perform test of pressure refueling system (Task 10-119).
- Refuel helicopter (Task 1-51).
- Bleed fuel system (Task 10-121).
- Perform operational check of affected fuel system (TM 55-1520-240-T).
- Inspect for leaks (Task 10-4).
- Install forward landing gear access panel (Task 2-181 or 2-179).

Tasks 10-75 and 10-76 deleted.

END OF TASK

INITIAL SETUP

Applicable Configurations:

All

Tools:

Aircraft Mechanic's Tool Kit, NSN 5180-00-323-4692

Material:

- Barrier Material (E80)
- Tape (E388)
- Paper Tags (E264)

Personnel Required:

Medium Helicopter Repairer

Equipment Condition:

- Battery Disconnected (Task 1-39)
- Electrical Power Off
- Helicopter Grounded (Task 1-29)
- Affected Tank Defueled (Task 10-34 or 10-35)
- Fuel Level Transmitter Removed (Task 8-81)
- Aft Fuel Tank Boost Pump Removed (Task 10-79)

General Safety Instructions:

WARNING

All regulations and instructions for handling fuel shall be strictly observed.

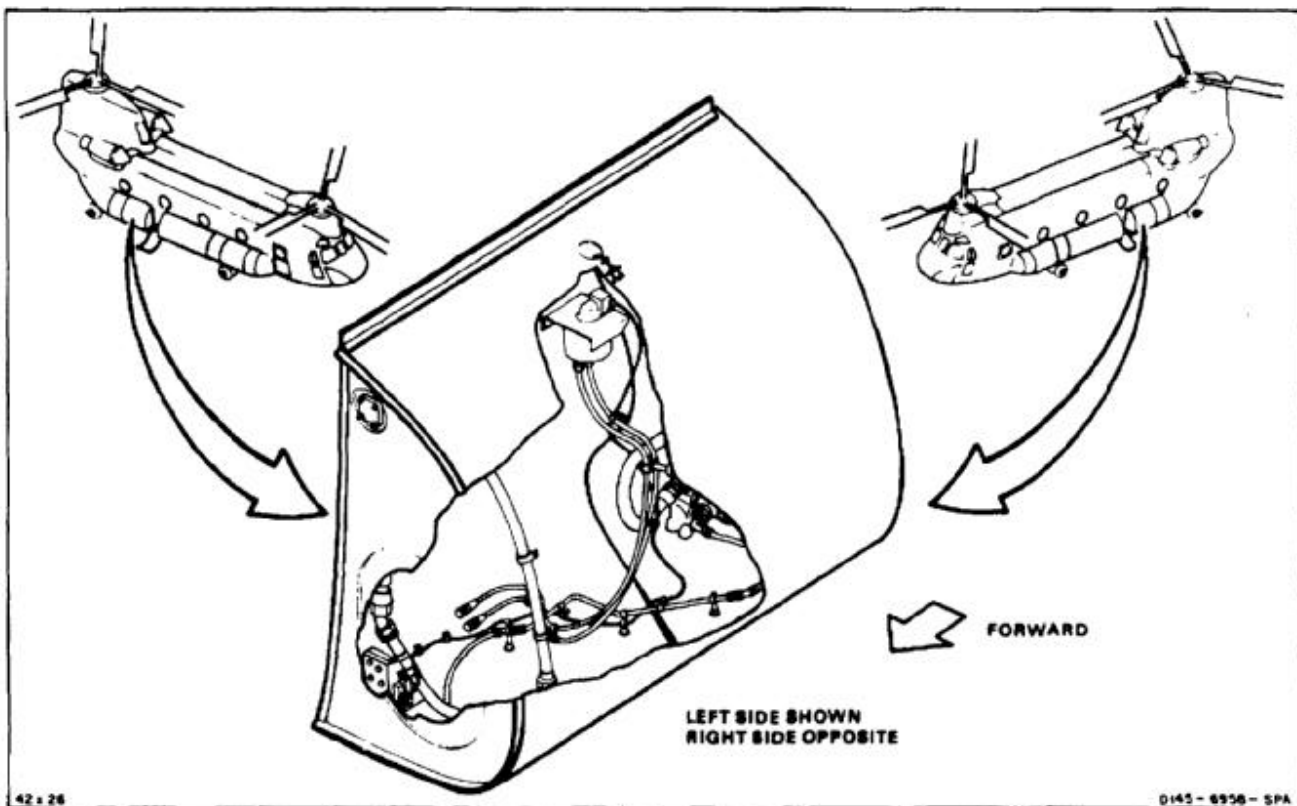

CAUTION

Do not puncture or scratch lining of fuel tank. If lining is broken, fuel penetrates and activates self-sealing layers. Activated layers swell and trap fuel. Activated green spongy material also contaminates fuel system. This makes it necessary to replace fuel tank and flush fuel system.

NOTE

Procedure is same to remove fuel lines and electrical wiring from No. 1 or No. 2 aft fuel tank. No. 1 (left) aft tank removal is shown here.

1. Tag four wires (1, 2, 3 and 4). Remove four screws (5 and 6) and washers (7 and 8). Remove four wire terminals (9 and 10). Install four screws and washers.
2. Loosen two screws (11). Remove four wires (1, 2, 3, and 4) from two clamps (12).
3. Remove screw (13), washer (14), and electrical wire clamp (15) from pump mounting bracket (16).
4. Remove screw (17), washer (18), and nut (19) from electrical wire clamp (20) to tube clamp (21). Disconnect clamps.
5. Remove screw (22), washer (23), and electrical wire clamp (24) from tube mounting bracket (25).

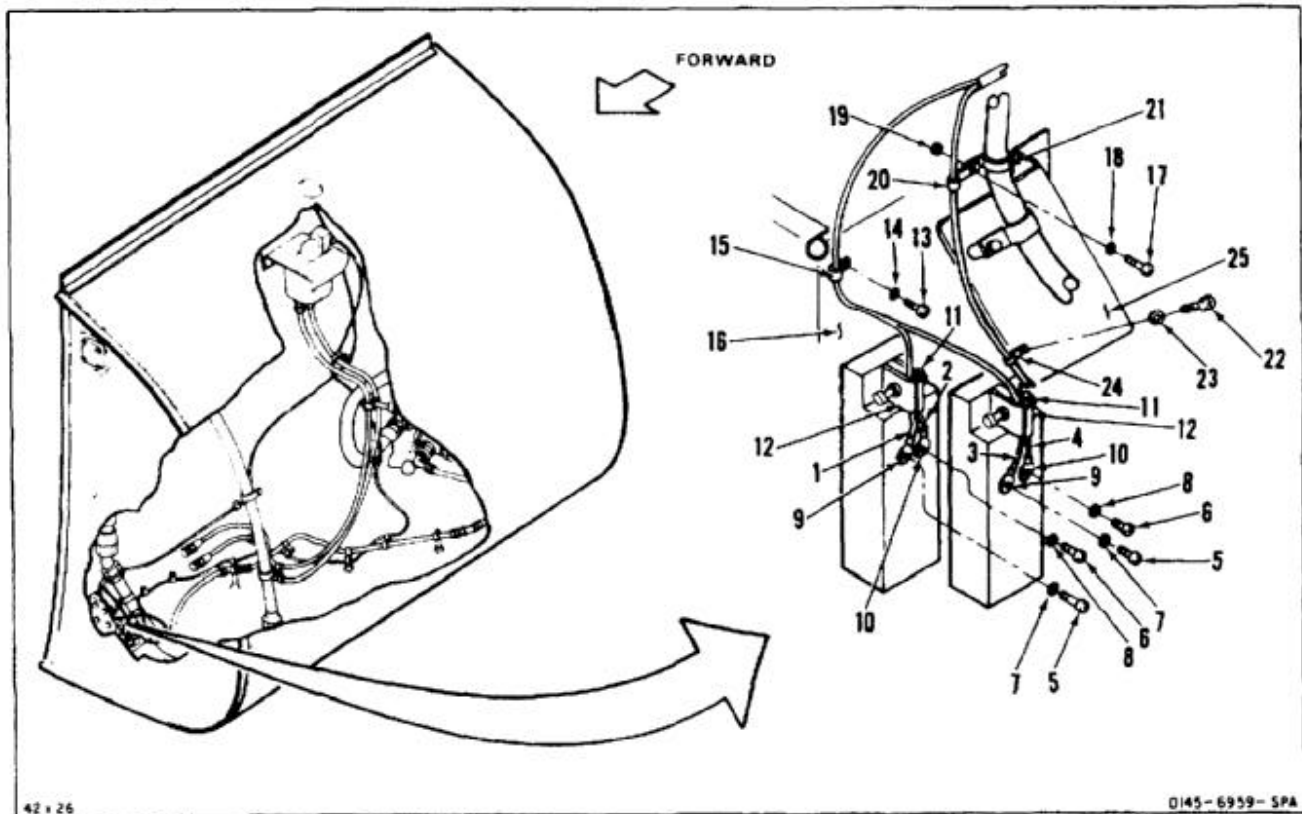

- | | |
|---|---|
| <p>6. Disconnect electrical connection (26).</p> <p>7. Remove screw (27), washer (28), and nut (29). Disconnect two electrical wire clamps (30 and 31) from hose clamp (32). Tag and remove electrical wire (33).</p> <p>8. Remove screw (34), washer (35) and spacer (36). Disconnect two hose clamps (37) from fuel cell mounting plate (38).</p> <p>9. Remove screw (39), washer (40), and nut (41). Disconnect wire clamp (42) from hose clamp (43).</p> <p>10. Remove screw (44), washer (45) and nut (46). Disconnect wire clamp (47) from tube clamp (48).</p> | <p>11. Remove screw (49), washer (50), and nut (51). Disconnect two hose clamps (52) from tube clamp (53).</p> <p>12. Disconnect two hose connections (54). Tag and remove hoses (55).</p> <p>13. Remove screw (56), washer (57), and spacer (58). Disconnect wire clamp (59) and tube clamp (60) from fuel cell mounting plate (61).</p> <p>14. Remove screw (62), washer (63), and two spacers (64 and 65). Disconnect cable clamp (66) and tube clamp (67) from fuel cell mounting plate (68).</p> <p>15. Tag and remove wires (69).</p> |
|---|---|

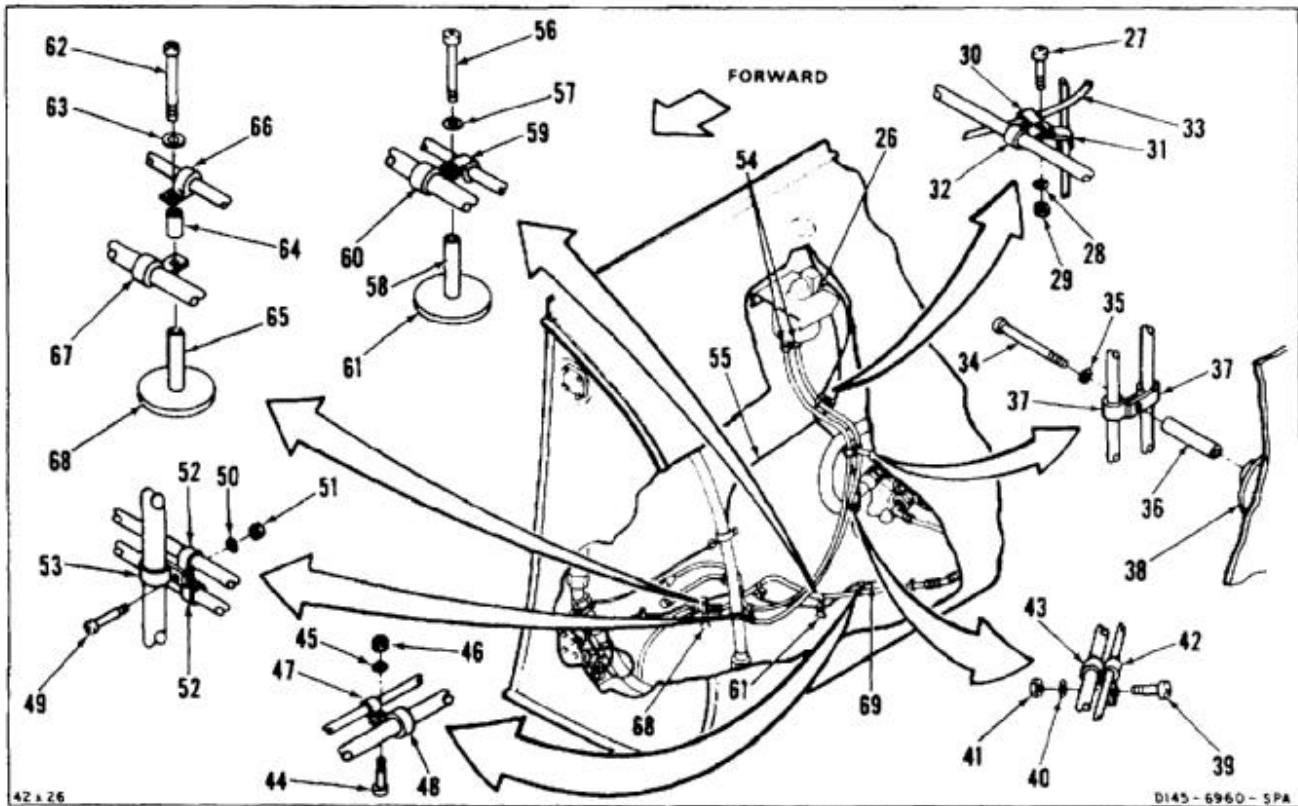

10-77 REMOVE AFT TANK FUEL LINES AND ELECTRICAL WIRING (Continued)**10-77**

16. Remove screw (70), washer (71), and nut (72). Disconnect two hose clamps (73 and 74). Separate two hoses (55).

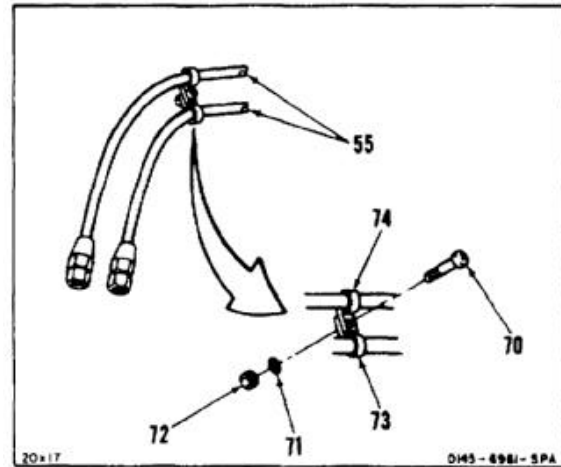

17. Cover access hole in tank (75). Use barrier material (E80) and tape (E388).

FOLLOW-ON MAINTENANCE:

None

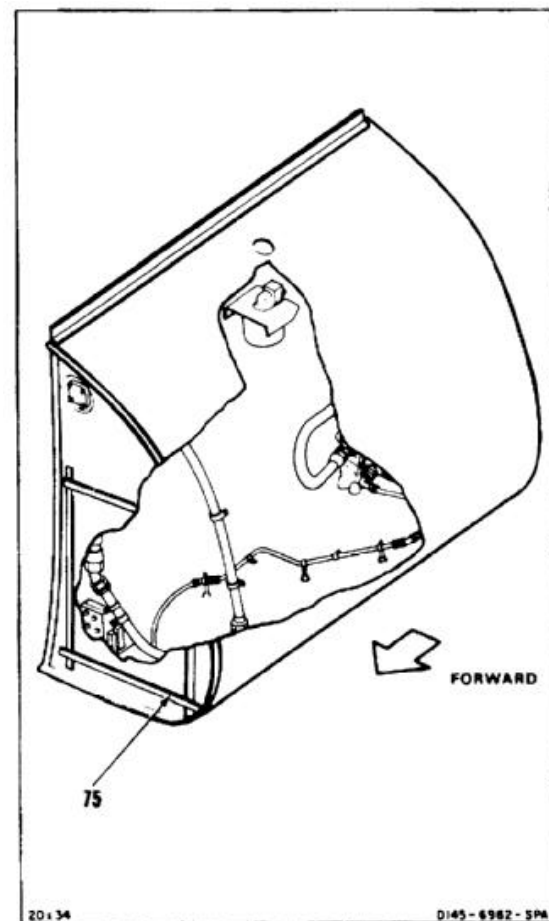

END OF TASK

INITIAL SETUP

Applicable Configurations:

All

Tools:

Aircraft Mechanic's Tool Kit, NSN 5180-00-323-4692
Torque Wrench, 700-1600 Inch-Pounds

Materials:

Dry Cleaning Solvent (E162)
Gloves (E186)
Cloths (E135)
Lockwire (E233)
Tape (E388)

Personnel Required:

Medium Helicopter Repairer
Inspector

References:

TM 55-1520-240-23P

General Safety Instructions:

WARNING

Dry cleaning solvent (E162) is flammable and toxic. It can irritate skin and cause burns. Use only in well-ventilated area, away from heat and open flame. In case of contact, immediately flush skin or eyes with water for at least **15 minutes**. Get medical attention for eyes.

WARNING

All regulations and instructions for handling fuels shall be strictly observed.

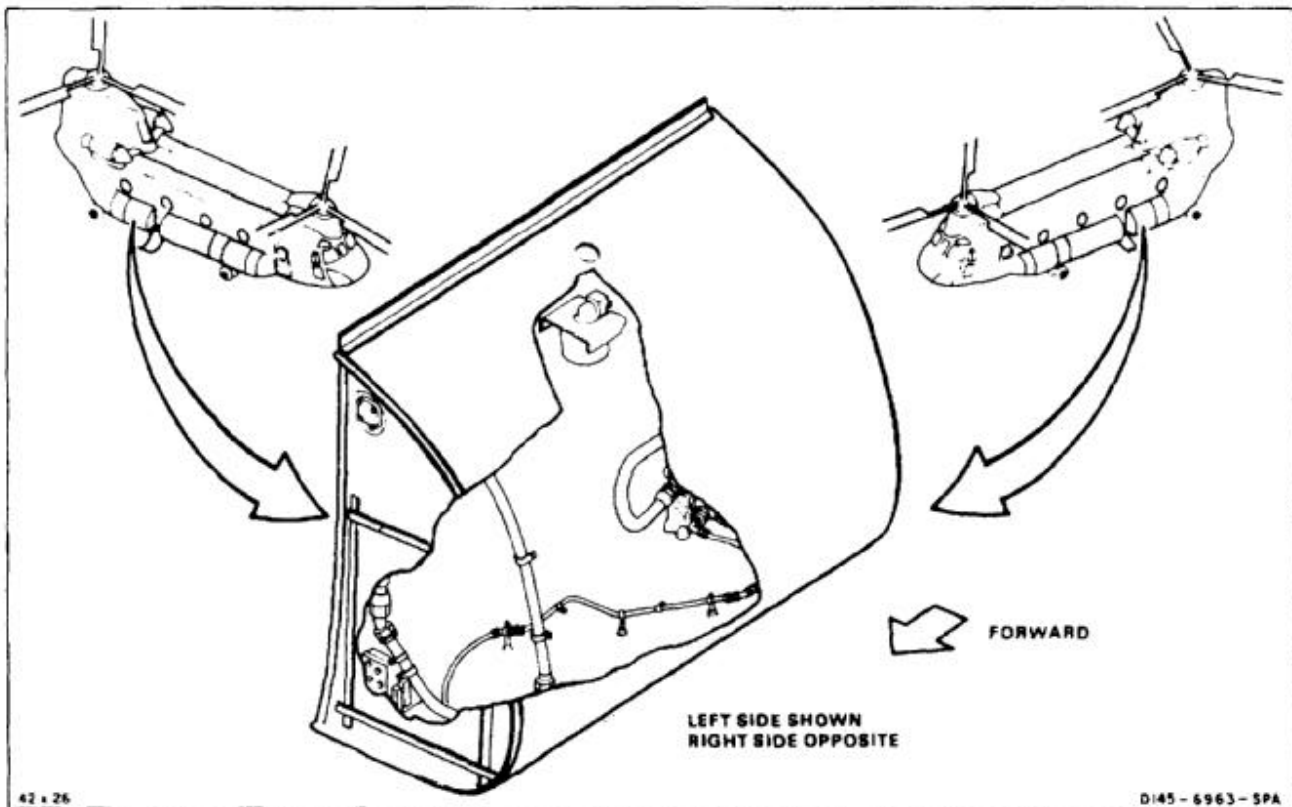

NOTE

Procedure is same to install fuel lines and electrical wiring in No. 1 or No. 2 aft fuel tank. No. 1 (left) tank installation is shown here.

1. Remove barrier material and tape from access hole in tank (1). Clean tape residue from tank. Use dry cleaning solvent (E162) and clean cloths (E135). Wear goggles to protect eyes. Wear gloves (E186).



Do not puncture or scratch lining of fuel tank. If lining is broken fuel penetrates and activates self-sealing layers. Activated layers swell and trap fuel. Activated green spongy material also contaminates fuel system. This makes it necessary to replace fuel tank and flush fuel system.

2. Position boost pump (2) on pump bracket (3). Install four bolts (4) and washers (5)
3. Remove plug from hose (6) and cap from boost pump (2). Position hose inside tank. Connect hose to boost pump. Torque hose connector to **1075 inch-pounds**.
4. Position wire harness (7) inside tank. Connect wire harness to boost pump (2). Lockwire connector to boost pump. Use lockwire (E233).

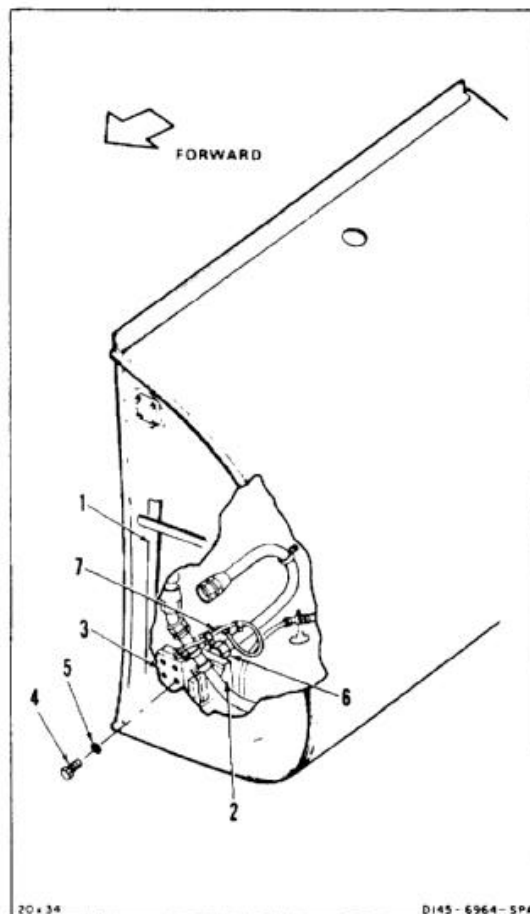

5. Position two hoses (8 and 9) inside fuel tank. Connect hose connectors (10 and 11).
6. Position two hoses (8 and 9), two hose clamps (12 and 13), and spacer (14) at fuel cell mounting plate (15). Install screw (16) and washer (17).
7. Position two hoses (8 and 9), two hose clamps (18 and 19), and tube clamp (20). Install screw (21), washer (22), and nut (23).
8. Position hose connectors (24 and 25) at approximate final installed location. Position hose clamps (26 and 27). Install screw (28), washer (29) and nut (30).
9. Position electrical wiring (31) inside fuel tank. Connect electrical connector (32).
10. Position wiring (31), wire clamp (33), tube clamp (34) and spacer (35) at fuel cell mounting plate (36). Install screw (37) and washer (38).
11. Position electrical wiring (31), wire clamp (39), hose clamp (40) and two spacers (41 and 42) at fuel cell mounting plate (43). Install screw (44) and washer (45).

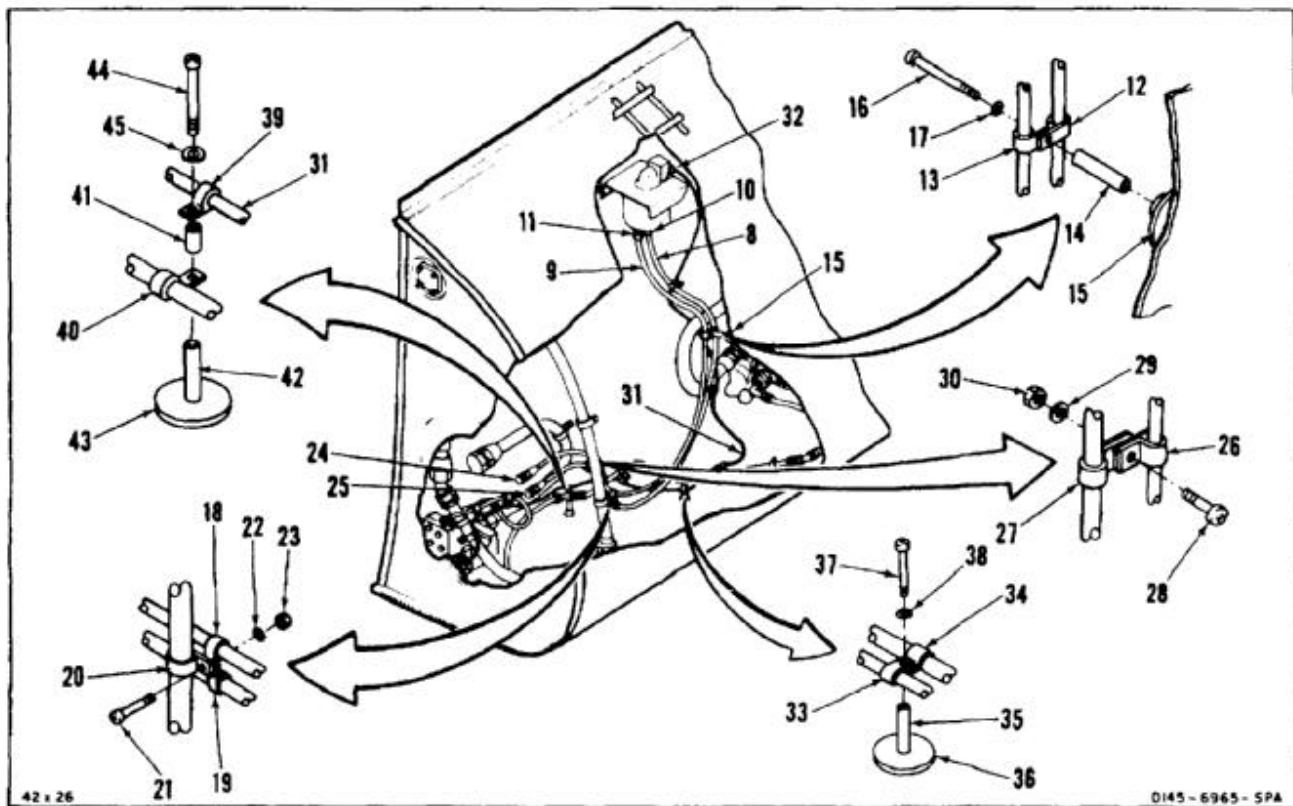

10-78 INSTALL AFT TANK FUEL LINES AND ELECTRICAL WIRING (Continued)

10-78

12. Remove barrier material and tape from hole (46) in tank. Clean tape residue from tank. Use dry cleaning solvent (E162) and clean cloths (E135). Wear goggles to protect eyes. Wear gloves (E186).
13. Position wiring harness (47) inside fuel tank. Push two terminal ends (48 and 49) of harness through hole (46) and tape terminal ends to outside of tank (1). Use tape (E388).
14. Position wiring harness (47), wiring (31), two electrical wiring clamps (50 and 51), and hose clamp (52). Install screw (53), washer (54) and nut (55).
15. Position hose (8), wiring (31) hose clamp (56) and electrical wire clamp (57). Install screw (58), washer (59), and nut (60).
16. Position wiring (31), wire clamp (61) and tube clamp (62). Install screw (63) washer (64) and nut (65).
17. Position wire harness connectors (66 and 67) at approximate final installed location. Position wire harness (7), electrical wiring (31), two harness clamps (68) and two electrical wiring clamps (69). Install two screws (70), washers (71) and nuts (72).
18. Position hose (6) and wiring (47) at approximate final installed location. Position hose clamp (73) and harness clamp (74). Install screw (75), washer (76) and nut (77).

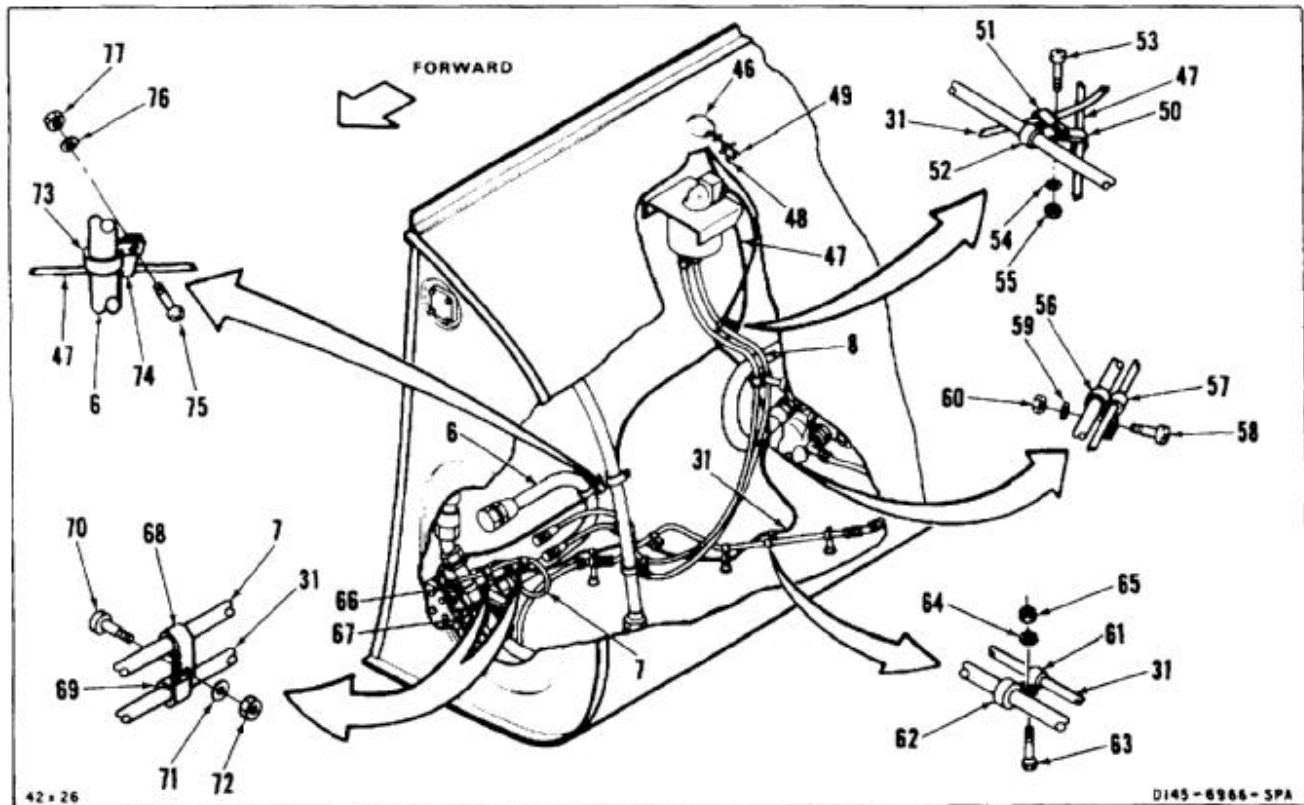

19. Position electrical wiring (47) and clamp (78) on tube mounting bracket (79). Install screw (80) and washer (81).
20. Position electrical wiring (47), wire clamp (82) on tube clamp (83). Install screw (84), washer (85) and nut (86).
21. Remove four screws (87 and 88) and four washers (89 and 90). Remove tags from wires (91, 92, 93, and 94). Position electrical wire terminals (95 and 96). Install four screws and washers.
22. Position four wires (91, 92, 93, and 94) in two clamps (97). Tighten two screws (98).
23. Position electrical wire (47) and wire clamp (99) on pump mounting bracket (100). Install screw (101) and washer (102).

INSPECT**FOLLOW-ON MAINTENANCE:**

- Install fuel level transmitter (Task 8-82).
- Perform vent system pressure test (Task 10-117).
- Install access door (Task 10-80).
- Install fuel level shut-off valve (Task 10-82).
- Test aft fuel tank (Task 10-32).
- Perform vent system flow test (Task 10-118) on affected tank.
- Perform test of pressure refueling system (Task 10-119) and fuel feed system (Task 10-120).
- Refuel helicopter (Task 1-51).
- Bleed fuel system (Task 10-121).
- Perform operational check of appropriate fuel system (TM 55-1520-240-T).
- Inspect for leaks (Task 10-4).
- Close and lock aft intertank pod panel (Task 2-188).

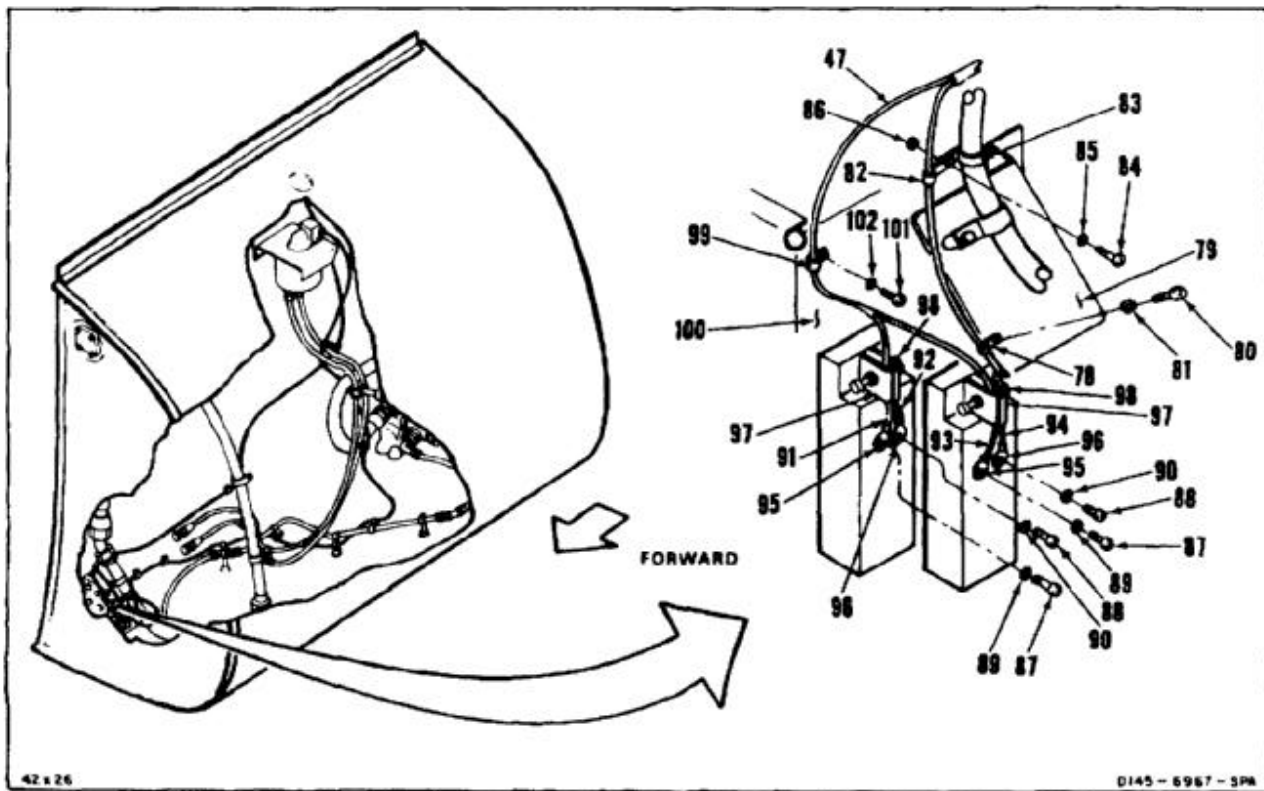

END OF TASK

10-372

10-79 REMOVE AFT FUEL TANK BOOST PUMP**10-79****INITIAL SETUP****Applicable Configurations:**

All

Tools:

Aircraft Mechanic's Tool Kit, NSN 5180-00-323-4692
 Wrench, Open End, 1-1/8 Inch
 Wrench, Open End, 1-1/2 Inch
 Grounded Container, 2 Quart or Equivalent

Materials:

Tape (E388)
 Cloths (E135)
 Barrier Material (E80)
 Paper Tags (E264)

Personnel Required:

Medium Helicopter Repairer

Equipment Condition:

Battery Disconnected (Task 1-39)
 Electrical Power Off
 Helicopter Grounded (Task 1-29)
 Aft Intertank Pod Lowered (Task 2-185)
 Aft Fuel Tank Defueled (Task 10-34 or 10-35)
 Aft Fuel Tank Purged (Task 10-2)
 Aft Auxiliary Fuel Tank Fuel Level
 Shut-Off Valve Removed (Task 10-81)

General Safety Instructions:**WARNING**

All regulations and instructions for handling fuels shall be strictly observed.

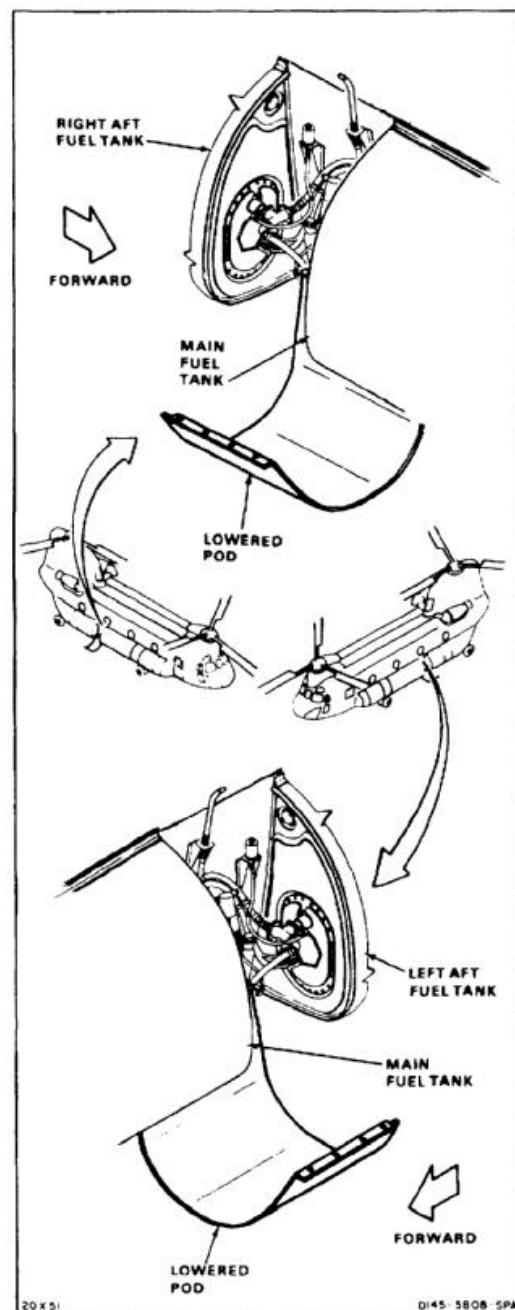

NOTE

Procedure is same to remove boost pump from No. 1 or No. 2 fuel system aft auxiliary fuel tank. Removal of No. 1 (left) boost pump is shown here.

REMOVE FORWARD ACCESS DOOR

1. Tag three connectors (1). Remove lockwire and disconnect three connectors. Tape wires and connectors to fuselage (2) for stowage. Use tape (E388).



When disconnecting fuel hoses from tank access door, do not allow elbows or fittings to turn. Otherwise, fittings can fail and cause fuel blockage.

2. Hold fitting (3) with wrench. Disconnect hose (4). Catch spilled fuel. Use grounded container. Remove conical seal (4.1) from hose fitting. Plug hose and cap fitting.
3. Hold adapter (5) with wrench. Disconnect hose (6). Catch spilled fuel. Use grounded container. Plug hose and cap adapter.
4. Hold fitting (7) with wrench. Disconnect hose (8). Catch spilled fuel. Use grounded container. Remove conical seal (8.1) from hose fitting. Plug hose and cap fitting.

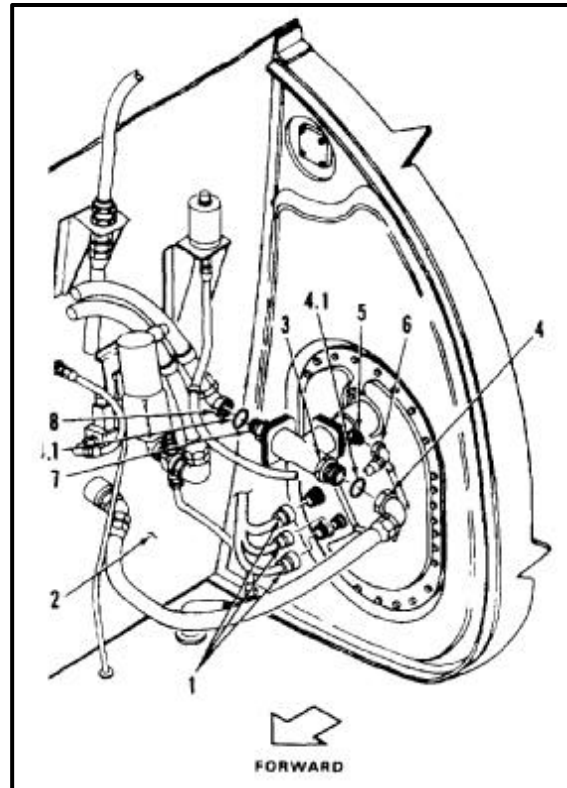

5. Remove lockwire and loosen three locknuts (9).

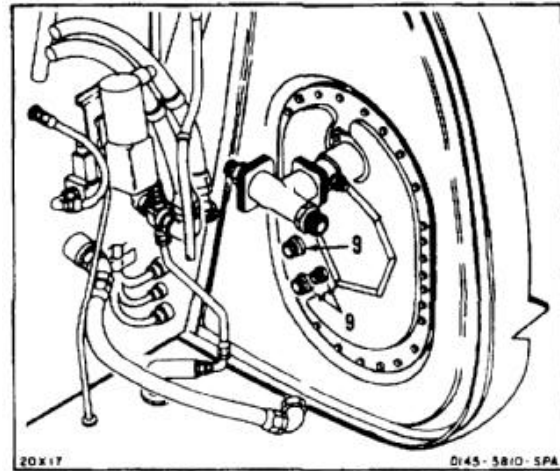

6. Remove 30 bolts (10), washers (11), and lanyard cable assembly (12). Clean up spilled fuel. Use cloths (E135).

CAUTION

Do not puncture or scratch lining of fuel tank. If lining is broken, fuel penetrates and activate self-sealing layers. Activated layers swell and trap fuel. Activated green spongy material also contaminates fuel system. This makes it necessary to replace fuel tank and flush fuel system.

7. Withdraw access door (13) from tank (14) for access to hose (15). Disconnect hose (15) from adapter (16) on inside of access door. Plug hose and cap adapter.
8. Tag three electrical cables (17). Remove three locknuts (9). Remove three receptacles (18) from access door (13).
9. Remove access door (13) and gasket (19).

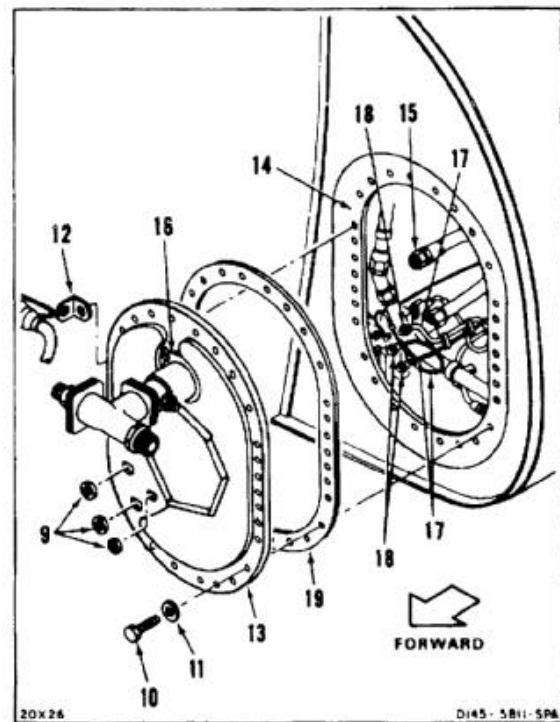

REMOVE BOOST PUMP

10. Remove lockwire and disconnect electrical connector (20) from boost pump (21).
11. Remove two nuts (22), washers (23), and screws (24) joining two electrical wire clamps (25) to two electrical cable clamps (26). Remove electrical cable (27) and clamps (26).
12. Remove nut (28), washer (29), and screw (30) joining electrical wire clamp (31) to hose clamp (32).
13. Disconnect hose connector (33) from boost pump (21). Remove hose (34) from tank. Cap boost pump and plug hose.
14. Remove four bolts (35) and washers (36).
15. Maneuver boost pump (21) from bracket (37). Remove boost pump (21).
16. Cover access hole in tank (14). Use barrier material (E80) and tape (E388).

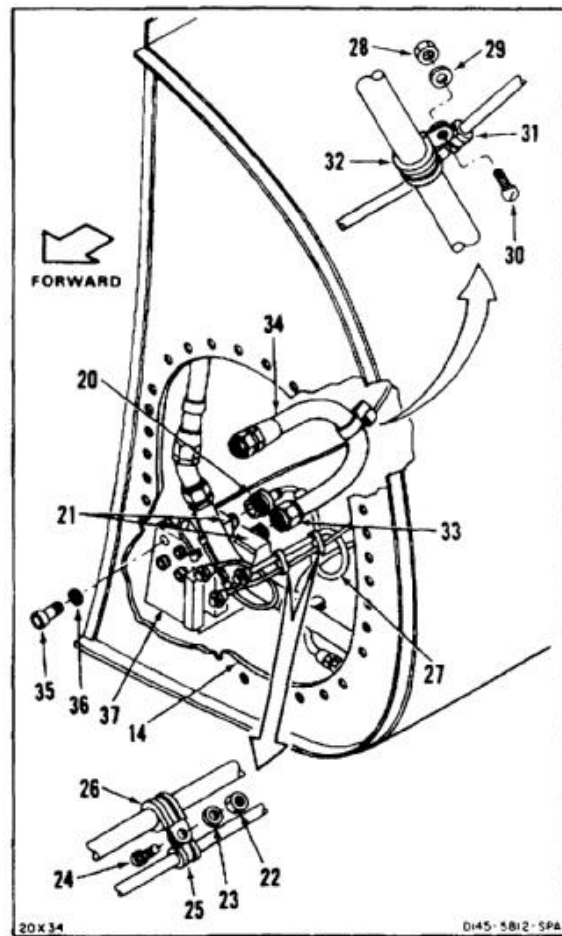
**FOLLOW-ON MAINTENANCE:**

None

END OF TASK

10-376

INITIAL SETUP

Applicable Configurations:

All

Tools:

Aircraft Mechanic's Tool Kit, NSN 5180-00-323-4692
 Torque Wrench, 30 to 150 Inch-Pounds
 Torque Wrench, 700 to 1600 Inch-Pounds
 Wrench, Open End, 1-1/8 Inch
 Wrench, Open End, 1-1/2 Inch

Materials:

Lockwire (E233)
 Dry Cleaning Solvent (E162)
 Gloves (E186)
 Cloths (E135)

Personnel Required:

Medium Helicopter Repairer
 Inspector

References:

TM 55-1520-240-23P

General Safety Instructions:**WARNING**

All regulations and instructions
 for handling fuels shall be strictly
 observed.

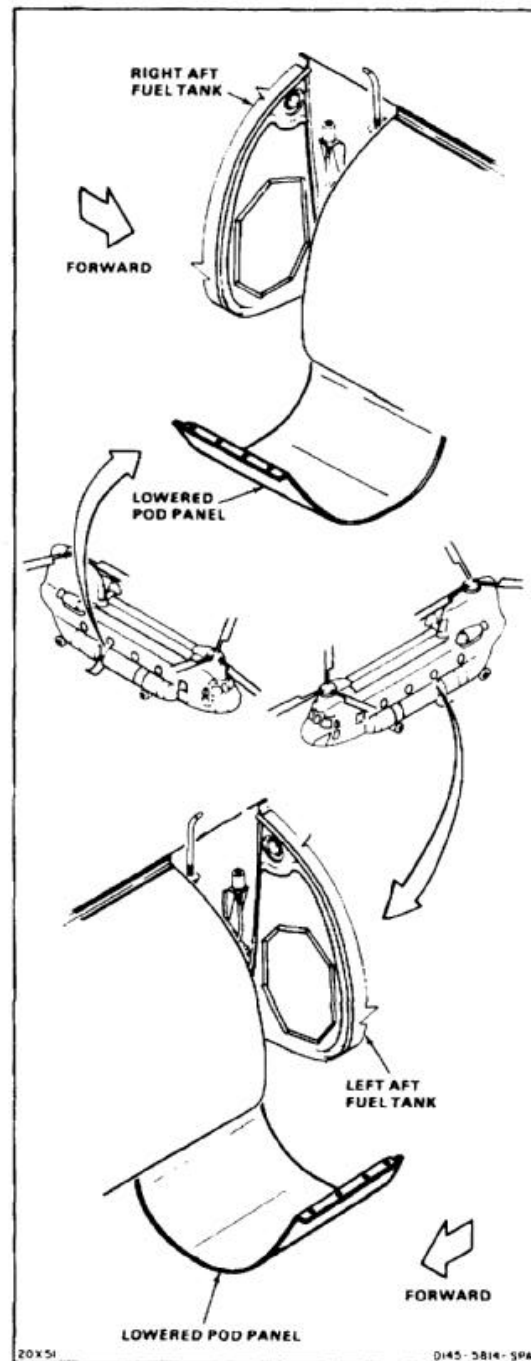

WARNING

Dry cleaning solvent (E162) is flammable and toxic. It can irritate skin and cause burns. Use only in well-ventilated area, away from heat and open flame. In case of contact, immediately flush skin or eyes with water for at least **15 minutes**. Get medical attention for eyes.

NOTE

Procedure is same to install boost pump in No. 1 or No. 2 fuel system aft fuel tank. Installation of No. 1 (left) boost pump is shown here.

INSTALL BOOST PUMP

1. Remove barrier material and tape from access hole in tank (1). Clean tape residue from tank. Use dry cleaning solvent (E162) and cloths (E135). Wear goggles to protect eyes. Wear gloves (E186).

CAUTION

Do not puncture or scratch lining of fuel tank. If lining is broken, fuel penetrates and activates self-sealing layers. Activated layers swell and trap fuel. Activated green spongy material also contaminates fuel system. This makes it necessary to replace fuel tank and flush fuel system.

2. Position boost pump (2) on pump bracket (3). Install four bolts (4) and washers (5).
3. Remove plug from hose (6) and cap from boost pump (2). Connect hose to boost pump. Torque hose connector to **1075 inch-pounds**.
4. Position hose clamp (7) and electrical wire clamp (8). Install screw (9), washer (10), and nut (11).
5. Position electrical cable (12). Position two electrical wire clamps (13) and two electrical cable clamps (14). Install two screws (15), washers (16), and nuts (17).
6. Connect electrical connector (18) to boost pump (2). Lockwire connector to boost pump. Use lockwire (E233).

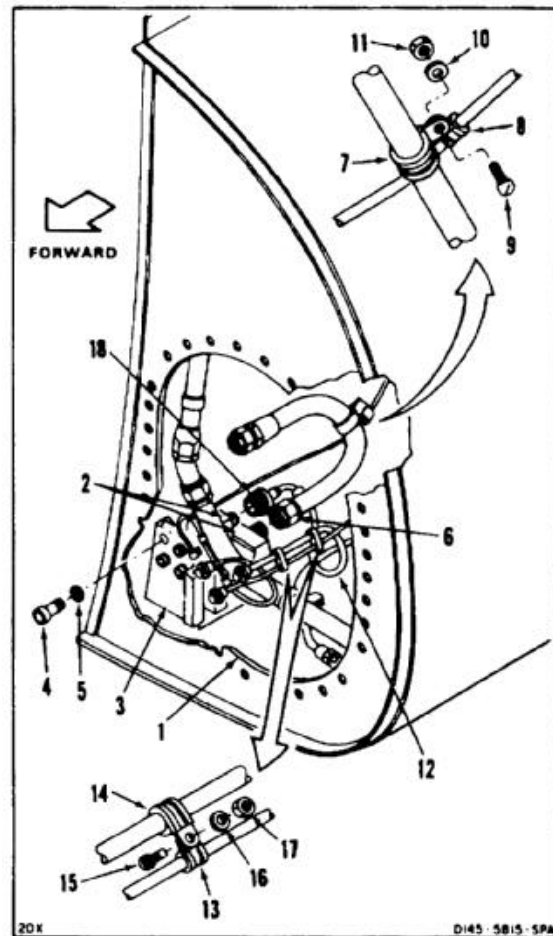
INSPECT

INSTALL ACCESS DOOR

7. Position gasket (19) and access door (20) next to access hole (1). Insert electrical receptacle (21) through hole (22) in door. Check that packing is installed on receptacle. Install keywasher (23.1). Install and hand tighten locknut (23) on electrical receptacle. Remove tag from cable (24).
8. Insert electrical receptacle (25) through hole (26) in door (20). Check that packing is installed on receptacle. Install and hand tighten locknut (27) on electrical receptacle. Remove tag from cable (28).
9. Insert electrical receptacle (29) through hole (30) in door (20). Install and hand tighten locknut (31) on electrical receptacle. Remove tag from cable (32).
10. Remove plug from hose (33) and cap from adapter (34) on inside of door (20). Connect hose to adapter.
11. Position gasket (19) and access door (20) against face of tank (2). Position lanyard release cable (35) as shown. Install 30 bolts (36) and washers (37). Torque bolts to **70 inch-pounds**.
12. Tighten three locknuts (23, 27, and 31). Bend tabs on keywasher (23.1).

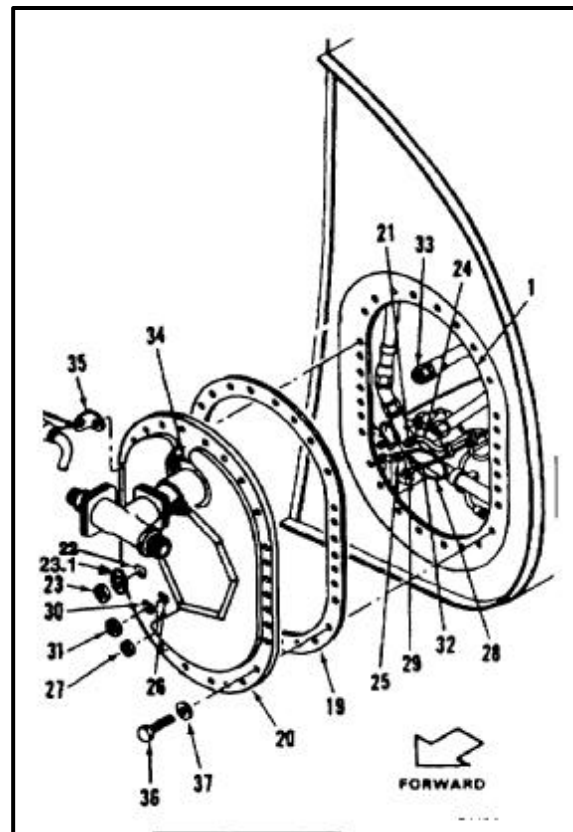

CAUTION

Do not allow adapters or fittings to turn when installing fuel hoses to tank access door. Otherwise, fittings can fail and cause fuel blockage.

13. Remove plug from hose (38) and cap from fitting (39). Install conical seal (38.1) in hose fitting. Hold fitting with wrench. Connect hose.
14. Remove plug from hose (40) and cap from adapter (41). Hold adapter with wrench. Connect hose.
15. Remove plug from hose (42) and cap from fitting (43). Install conical seal (42.1) in hose fitting. Hold fitting with wrench. Connect hose.
16. Remove tape attaching three electrical cables (44, 45, and 46) to fuselage (47).
17. Connect plug (48) to receptacle (21). Remove tag.
18. Connect plug (49) to receptacle (25). Remove tag.
19. Connect plug (50) to receptacle (29). Remove tag.
20. Lockwire plugs (48, 49, and 50). Use lockwire (E231).

INSPECT

FOLLOW-ON MAINTENANCE:

- Install fuel level shutoff valve (Task 10-82).
- Perform vent system flow test (Task 10-118).
- Refuel helicopter (Task 1-51).
- Bleed fuel system (Task 10-121).
- Perform operational check of appropriate fuel system (TM 55-1520-240-T).
- Close and lock aft intertank pod panel (Task 2-188).

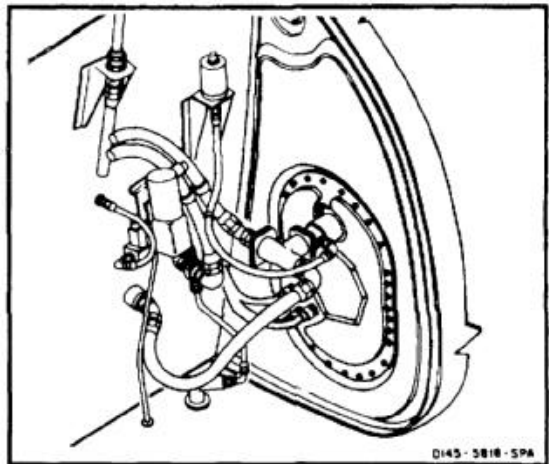
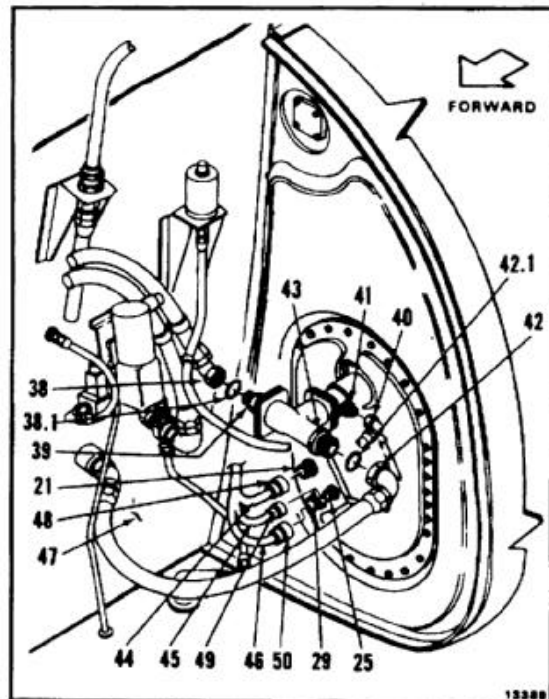

END OF TASK

10-380

INITIAL SETUP

Applicable Configurations:

All

Tools:

Aircraft Mechanic's Tool Kit, NSN 5180-00-323-4692
 Grounded Container, 2 Quart or Equivalent

Materials:

Cloths (E135)
 Barrier Material (E80)
 Tape (E388)
 Paper Tags (E264)

Personnel Required:

Medium Helicopter Repairer

Equipment Condition:

Battery Disconnected (Task 1-39)
 Electrical Power Off
 Helicopter Grounded (Task 1-29)
 All Tanks on Affected Side of Helicopter Defueled
 and Both Crossover Valves Closed (Task 10-34
 or 10-35)
 Aft Intertank Access Panel on Affected Side of
 Helicopter Removed (Task 2-185)

General Safety Instructions:**WARNING**

All regulations and instructions
 for handling fuels shall be strictly
 observed.

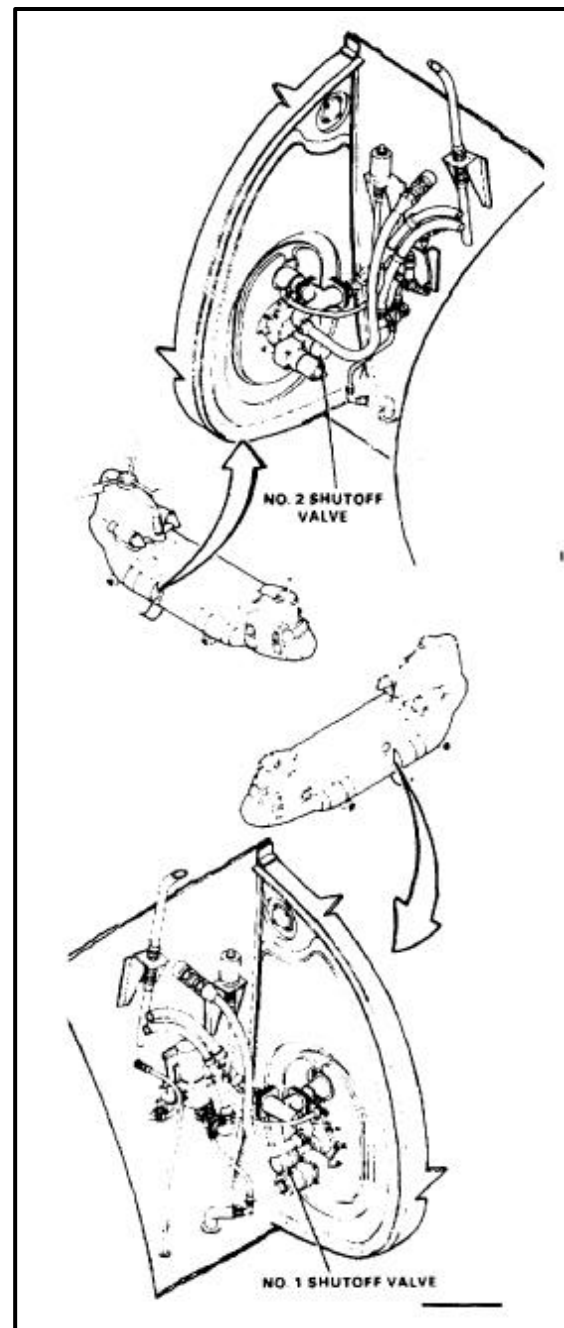

NOTE

Procedure is similar to remove fuel level shutoff valve in No. 1 or No. 2 fuel system. Removal of No. 2 (right) valve is shown here.

METHOD USING VALVE 114PS494-1 AND ELBOW ASSEMBLY 401545-1 WITHOUT 11

1. Remove four bolts (1), washers (2), and nuts (3).
2. Slide union adapter (4) forward, into elbow assembly (5). Use grounded container to catch spilled fuel.
3. Disconnect electrical connector (6).
4. Remove three gaskets (7), valve (8), and spacer (9).
5. Remove adapter (4) and elbow (5) from tee (11). Plug holes in adapter, elbow, and tee.
6. Remove ten bolts (12) and washers (13).
7. Withdraw fuel valve (16) from tank (14) for access to two hose connections (15). Tag and disconnect hose connections.
8. Maneuver fuel valve (16) from tank (14). Cover hole in tank. Use barrier material (E80) and tape (E388).
9. Remove packing (17) from mounting flange of fuel valve (16).
10. Go to step 23.

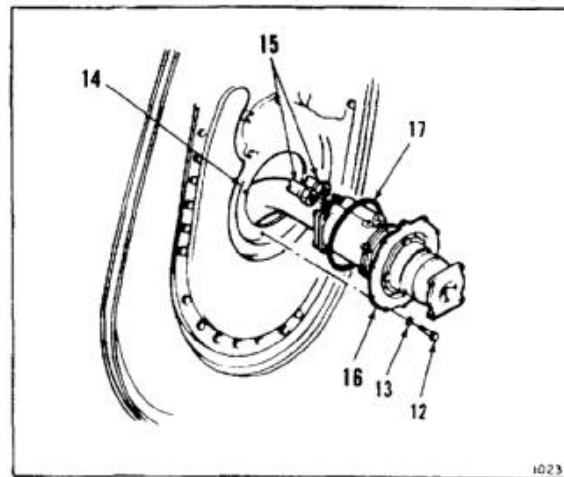
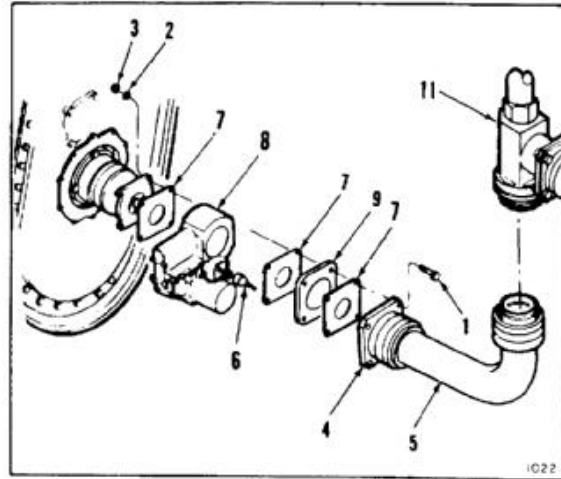

METHOD USING VALVE 114PS494-1 AND ELBOW ASSEMBLY 401116-3 WITHOUT 11

11. Remove four bolts (18), washers (19), and nuts (20). Loosen four nuts (21).
12. Slide union adapter (22) forward, into elbow assembly (23). Use grounded container to catch spilled fuel.
13. Remove gasket (6).
14. Remove lockwire (24). Loosen coupling nut (25).
15. Remove adapter (22) and elbow (23) from tee (10). Plug holes in adapter, elbow, and tee.

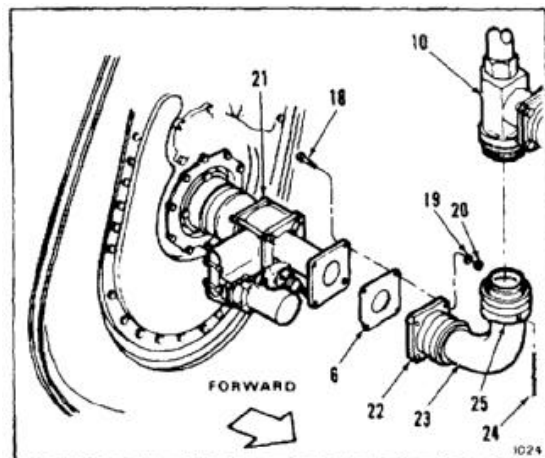

16. Disconnect electrical connector (6).
17. Remove four bolts (27), washers (28), and nuts (21).
18. Remove tube (29), gaskets (7), spacer (9), and valve (8).
19. Remove ten bolts (12) and washers (13).
20. Withdraw fuel valve (16) from tank (14) for access to two hose connections (15). Tag and disconnect hose connections.
21. Maneuver fuel valve (16) from tank (14). Cover hole in tank. Use barrier material (E80) and tape (E388).
22. Remove packing (17) from mounting flange of fuel valve (16).
23. Remove four bolts (30) and washers (31).

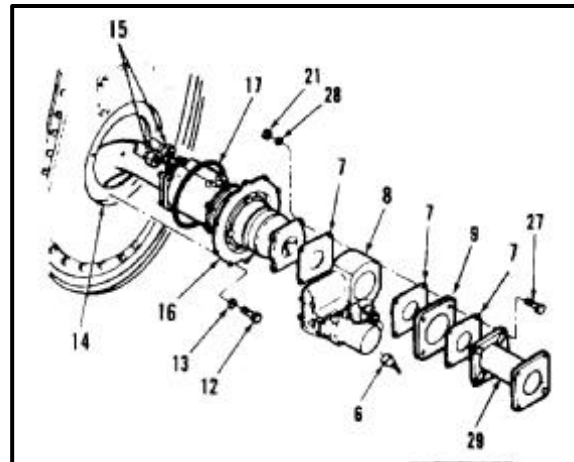

Breakaway fitting (32) is fragile.
Handle with care.

24. Remove fitting (32) and packing (33) from valve (16).
25. Remove four bolts (34) and washers (35). Remove tube (37).
26. Clean up spilled fuel. Use cloths (E135).

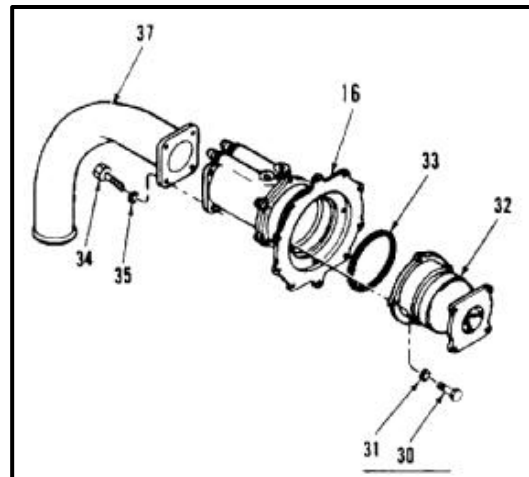

METHOD USING VALVE 114PS494-2 AND ELBOW ASSEMBLY 401545-1 WITH 11

27. Remove eight bolts (1) and washers (2).
28. Slide union adapter (4) forward, into elbow assembly (5). Use grounded container to catch spilled fuel.
29. Disconnect electrical connector (6).
30. Remove five gaskets (7), valve (8), and spacer (9).
31. Remove adapter (4) and elbow (5) from tee (11). Plug holes in adapter, elbow, and tee.

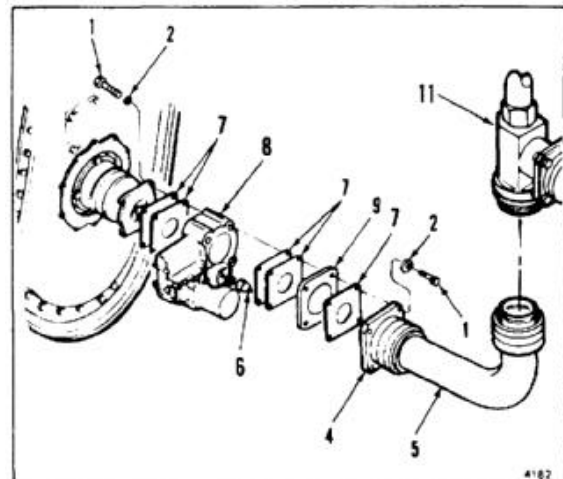

32. Remove ten bolts (12) and washers (13).
33. Withdraw fuel valve (16) from tank (14) for access to two hose connections (15). Tag and disconnect hose connections.
34. Maneuver fuel valve (16) from tank (14). Cover hole in tank. Use barrier material (E80) and tape (E388).
35. Remove packing (17) from mounting flange of fuel valve (16).
36. Go to step 49.

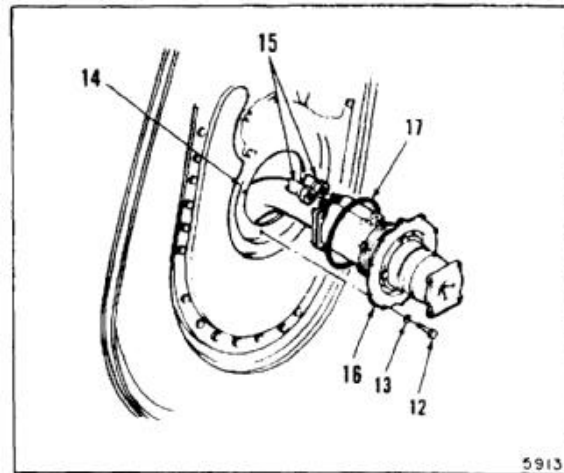

METHOD USING VALVE 114PS494-2 AND ELBOW ASSEMBLY 401116-3 WITH 11

37. Remove four bolts (18), washers (19), and nuts (20). Loosen eight bolts (27).
38. Slide union adapter (22) forward, into elbow assembly (23). Use grounded container to catch spilled fuel.
39. Remove gasket (6).
40. Remove lockwire (24). Loosen coupling nut (25).
41. Remove adapter (22) and elbow (23) from tee (10). Plug holes in adapter, elbow, and tee.

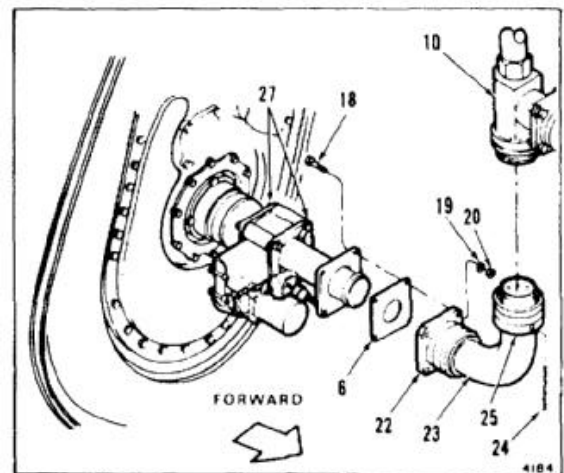

42. Disconnect electrical connector (6).
43. Remove eight bolts (27) and washers (28).
44. Remove tube (29), gaskets (7), spacer (9), and valve (8).
45. Remove ten bolts (12) and washers (13).
46. Withdraw fuel valve (16) from tank (14) for access to two hose connections (15). Tag and disconnect hose connections.
47. Maneuver fuel valve (16) from tank (14). Cover hole in tank. Use barrier material (E80) and tape (E388).
48. Remove packing (17) from mounting flange of fuel valve (16).

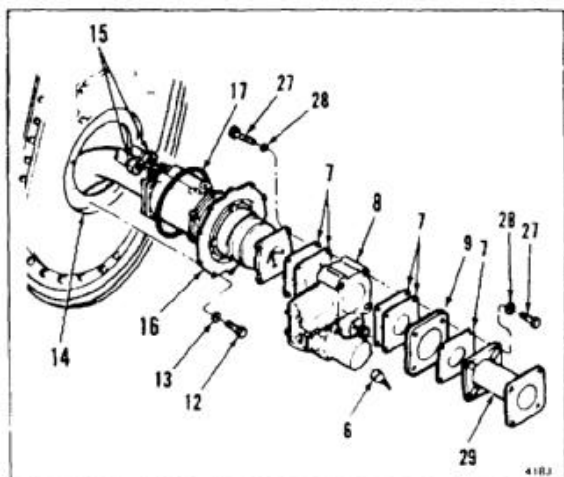

10-81 REMOVE AFT TANK FUEL LEVEL SHUTOFF VALVE (Continued)**10-81**

49. Remove four bolts (30) and washers (31).



Breakaway fitting (32) is fragile.
Handle with care.

50. Remove fitting (32) and packing (33) from valve (16).
51. Remove four bolts (34) and washers (35).
Remove tube (37).
52. Clean up spilled fuel. Use cloths (E135).

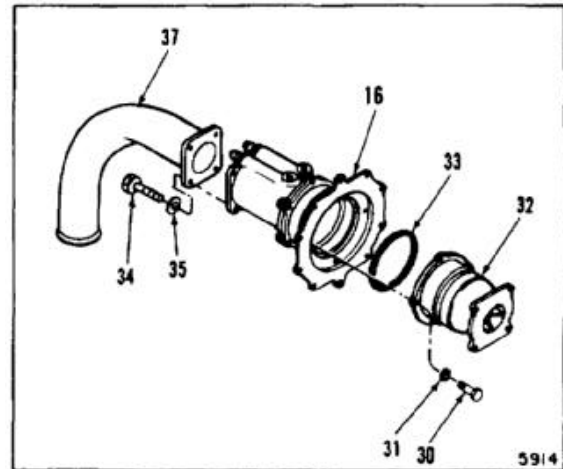
***FOLLOW-ON MAINTENANCE:***

None

END OF TASK

INITIAL SETUP

Applicable Configurations:

All

Tools:

Aircraft Mechanic's Tool Kit, NSN 5180-00-323-4692

Materials:

Dry Cleaning Solvent (E162)

Gloves (E186)

Lockwire (E233)

Sealant (E342.1)

Parts:

Packings

Gaskets

Personnel Required:

Medium Helicopter Repairer

Inspector

References:

TM 55-1520-240-23P

General Safety Instructions:**WARNING**

All regulations and instructions for handling fuels shall be strictly observed.

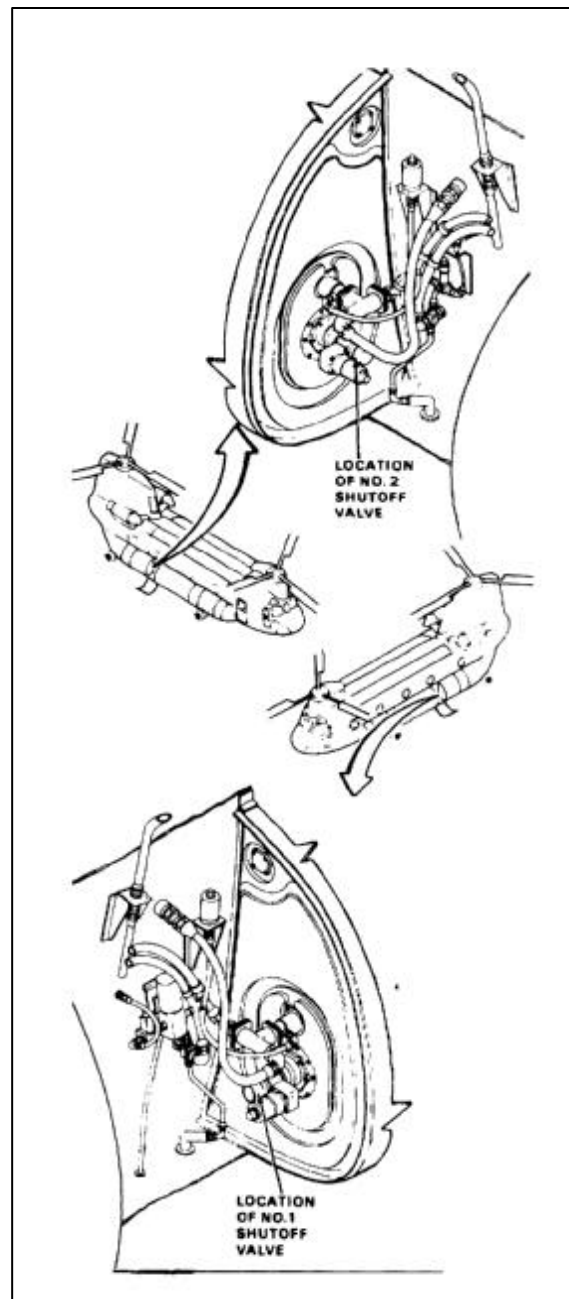

NOTE

Procedure is similar to install fuel level shutoff valve in No. 1 or No. 2 fuel system. Installation of No. 2 (right) valve is shown here.

METHOD USING VALVE 114PS494-1 AND ELBOW ASSEMBLY 401545-1 (WITHOUT 11)

1. Position tube (1) on fuel valve (2). Make sure two hose connections (3) are at top and tube points down. Install four bolts (4) and washer (5).



Breakaway fitting (8) is fragile. Handle with care.

2. Position packing (7) on fitting (8). Position fitting on valve (2). Install four bolts (9) and washers (10).

3. Install packing (11) on flange of valve (2).



Dry cleaning solvent (E162) is flammable and toxic. It can irritate skin and cause burns. Use only in well-ventilated area, away from heat and open flame. In case of contact, immediately flush skin or eyes with water for at least **15 minutes**. Get medical attention for eyes.

4. Remove tape and barrier material from hole in tank (12). Clean tape residue from tank. Use dry cleaning solvent (E162). Wear goggles (E473) to protect eyes. Wear gloves (E186).
5. Maneuver fuel valve (2) through hole in tank (12), tube (1) pointing down. Remove tags and connect two hoses (13) to valve connections (3).
6. Position flange of valve (2) against tank (12), tube (1) pointing down. Install ten bolts (14) and washers (15).

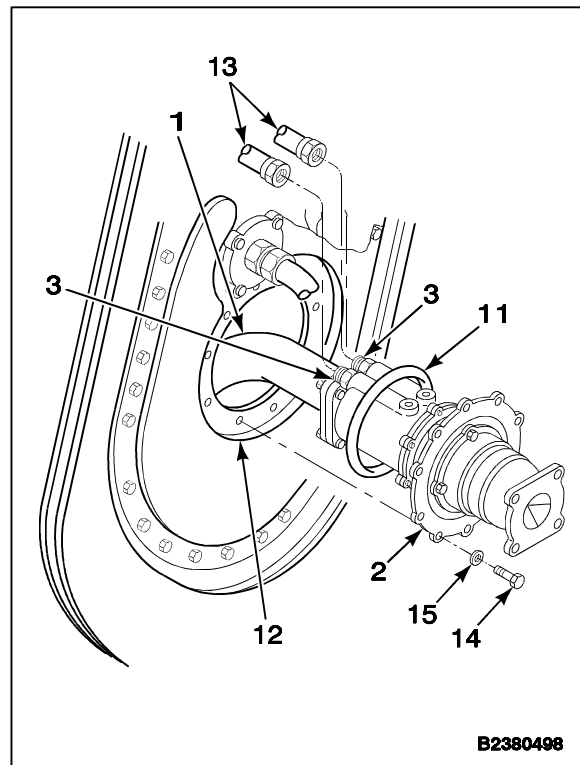
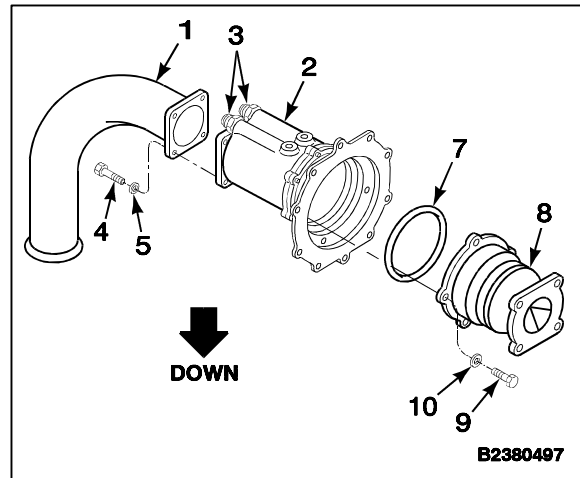

7. Remove plugs from adapter (16), elbow (17), and tee (18).
8. Position adapter (16) and elbow (17) on tee (18).

NOTE

Gaskets (20.1) P/N BACG10BS32 are used with shutoff valve (21) P/N AV16B2101D-1.

9. Position three gaskets (20), two gaskets (20.1) coated with sealant (E342.1), valve (21), and spacer (22) on fitting (8).
10. Slide adapter (16) aft. Secure adapter. Use four bolts (23), washers (24), and nuts (25). Tighten coupling (26) and bolts.
11. Connect electrical connector (27).

INSPECT

Go to Follow-On Maintenance.

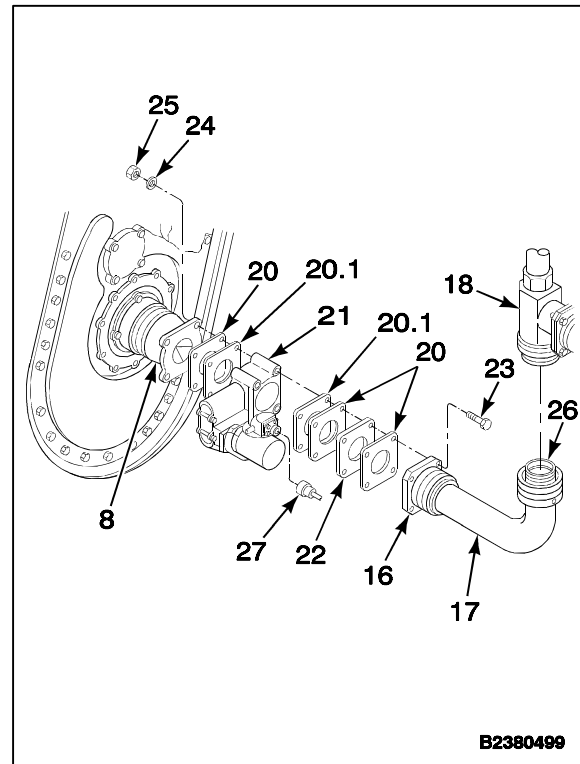

METHOD USING VALVE 114PS494-1 AND ELBOW ASSEMBLY 401116-3 (WITHOUT 11)

12. Perform steps 1 and 2.
13. Install packing (11) in fuel valve (2).
14. Remove barrier material and tape from hole in tank (12). Maneuver fuel valve (2) partly into tank.
15. Connect two hoses (13).
16. Install ten bolts (14) and washers (15).

NOTE

Gaskets (21.1) P/N BACG10BS32 are used with shutoff valve (22) P/N AV16B2101D-1.

17. Position tube (27), three gaskets (21), two gaskets (21.1) coated with sealant (E342.1), spacer (23), and valve (22) on fitting (8). Secure parts loosely with four bolts (28), washers (29), and nuts (30).
18. Connect electrical connector (16).

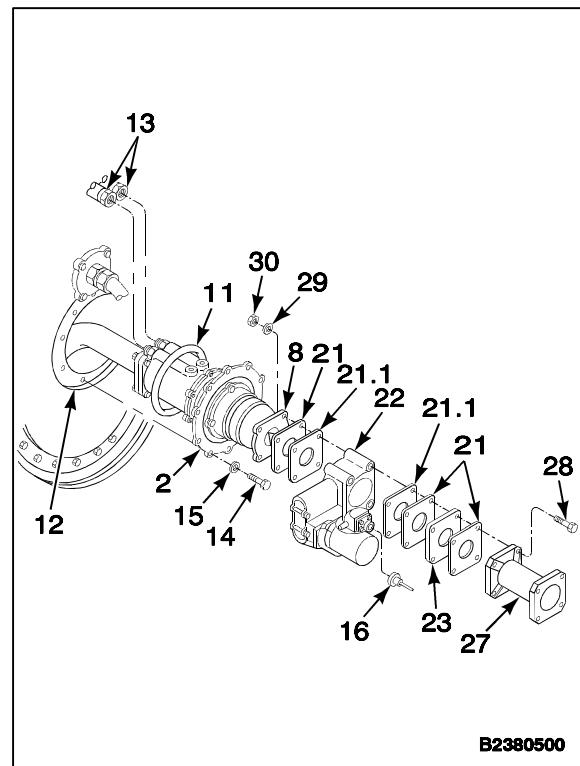

CAUTION

Two snap rings must be positioned at upper end of elbow where it connects to tee. Be sure flanges of snap rings are together. Damage to parts can occur if installation is not as shown.

19. Remove plugs from adapter (31), elbow (32), and tee (19).
20. Install elbow (32) with the two snap rings on tee (19). Tighten coupling (34) on tee. Install lockwire (E233) (35).
21. Position gasket (21) on adapter (31). Slide adapter aft and install four bolts (36), washers (37), and nuts (38). Tighten coupling (39).

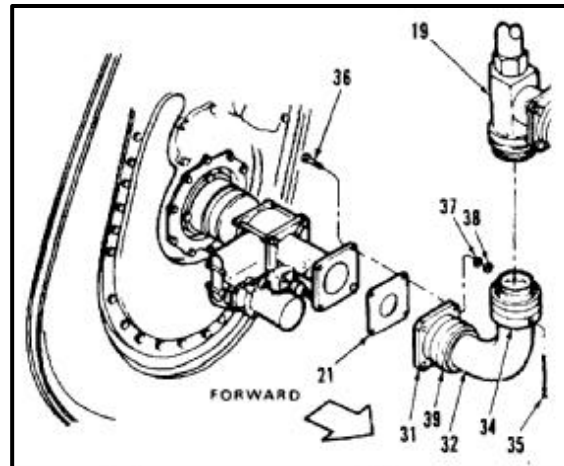
**INSPECT****METHOD USING VALVE 114PS494-2 AND ELBOW ASSEMBLY 401545-1 WITH 11**

22. Position tube (1) on fuel valve (2). Make sure two hose connections (3) are at top and tube points down. Install four bolts (4), washer (5).

CAUTION

Breakaway fitting (8) is fragile. Handle with care.

23. Position packing (7) on fitting (8). Position fitting on valve (2). Install four bolts (9) and washers (10).

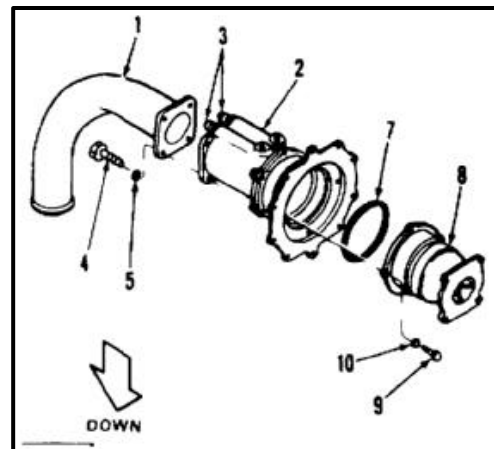

24. Install packing (11) on flange of valve (2).

WARNING

Dry cleaning solvent (E162) is flammable and toxic. It can irritate skin and cause burns. Use only in well-ventilated area, away from heat and open flame. In case of contact, immediately flush skin or eyes with water for at least **15 minutes**. Get medical attention for eyes.

25. Remove tape and barrier material from hole in tank (12). Clean tape residue from tank. Use dry cleaning solvent (E162). Wear goggles to protect eyes. Wear gloves (E186).
26. Maneuver fuel valve (2) through hole in tank (12), tube (1) pointing down. Remove tags and connect two hoses (13) to valve connections (3).
27. Position flange of valve (2) against tank (12), tube (1) pointing down. Install ten bolts (14) and washers (15).
28. Remove plugs from adapter (16), elbow (17), and tee (18).
29. Position adapter (16) and elbow (17) on tee (18).

NOTE

Gaskets (20.1) are used with shutoff valve pin AV16B2101D-1 only.

30. Position three gaskets (20), two gaskets (20.1) coated with sealant (E342.1), valve (21), and spacer (22) on fitting (8).
31. Slide adapter (16) aft. Secure adapter. Use eight bolts (23), and washers (24). Tighten coupling (26) and bolts.
32. Connect electrical connector (27).

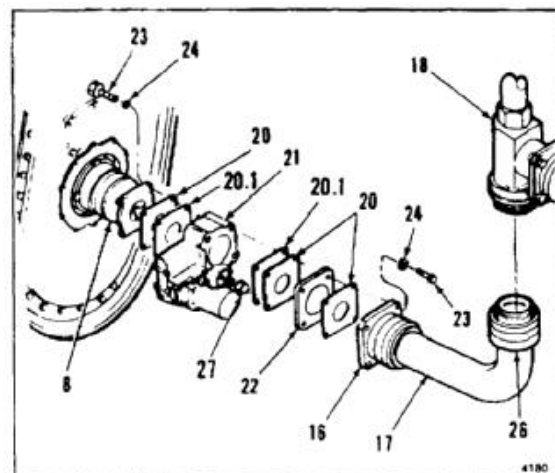
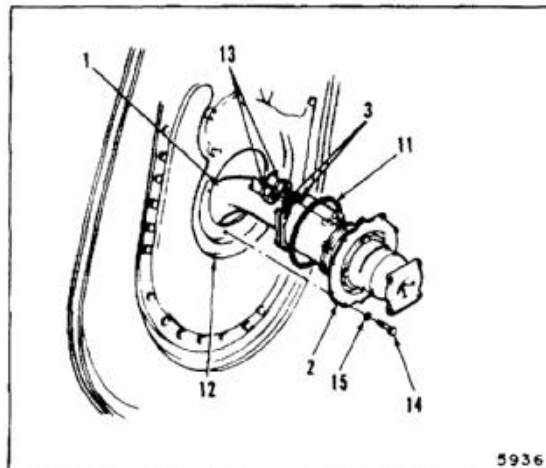

INSPECT

Go to Follow-On Maintenance.

METHOD USING VALVE 114PS494-2 AND ELBOW ASSEMBLY 401116-3 WITH 11

33. Perform steps 1 and 2.
34. Install packing (11) in fuel valve (2).
35. Remove barrier material and tape from hole in tank (12). Maneuver fuel valve (2) partly into tank.
36. Connect two hoses (13).
37. Install ten bolts (14) and washers (15).

NOTE

Gaskets (21.1) are used with shutoff valve pin AV16B2101D-1 only.

38. Position tube (27), three gaskets (21), two gaskets 21.1 coated with sealant (E342.1), spacer (23), and valve (22) on fitting (8). Secure parts loosely with eight bolts (28) and washers (29).
39. Connect electrical connector (16).
40. Remove plugs from adapter (31), elbow (32), and tee (19).



Two snap rings (33) must be positioned at upper end of elbow where it connects to tee. Be sure flanges of snap rings are together. Damage to parts can occur if installation is not as shown.

41. Check that snap rings (33) are aligned.
42. Install elbow (32) on tee (19). Tighten coupling (34) on tee. Install lockwire (E233) (35).
43. Position gasket (21) on adapter (31). Slide adapter aft and install four bolts (36), washers (37), and nuts (38). Tighten coupling (34) and bolts (36).

INSPECT**FOLLOW-ON MAINTENANCE:**

- Perform vent system flow test (Task 10-118).
- Test aft tank (Task 10-32).
- Refuel aircraft (Task 1-51).
- Check operation of fuel shutoff valve (TM 55-1520-240-T).
- Bleed fuel system (Task 10-121).
- Check for leaks (Task 10-4).
- Install aft intertank access panel (Task 2-188).

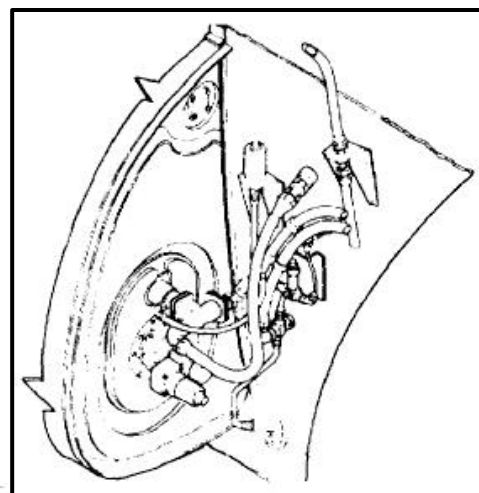
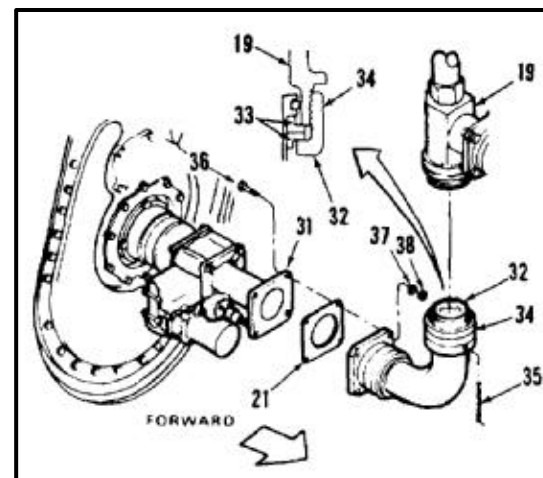
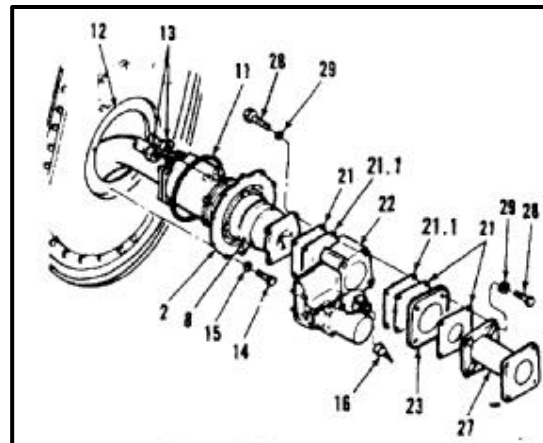

END OF TASK

INITIAL SETUP

Applicable Configurations:

All

Tools:

Aircraft Mechanic's Tool Kit, NSN 5180-00-323-4692

Materials:

Barrier Material (E80)
Tape (E388)

Personnel Required:

Medium Helicopter Repairer

Equipment Condition:

Battery Disconnected (Task 1-39)
Electrical Power Off
Helicopter Grounded (Task 1-29)
Aft Tank Defueled (Task 10-34 or 10-35)
Left Aft Access Door Raised And Latched Or Right Aft Access Panel Lowered, As Required (Task 2-185)
Fuel Tank Purged (Task 10-2)

General Safety Instructions:



All regulations and instructions for handling fuels shall be strictly observed.

NOTE

Procedure is same to remove vent valve from No. 1 or No. 2 aft auxiliary fuel tank. Removal of No. 2 (right) vent valve is shown here.

1. Disconnect vent hose (1) from fitting (2).
2. Remove 30 bolts (3) and washers (4).
3. Pullout door (5) and gasket (6) and disconnect vent hose (7). Remove door and gasket.

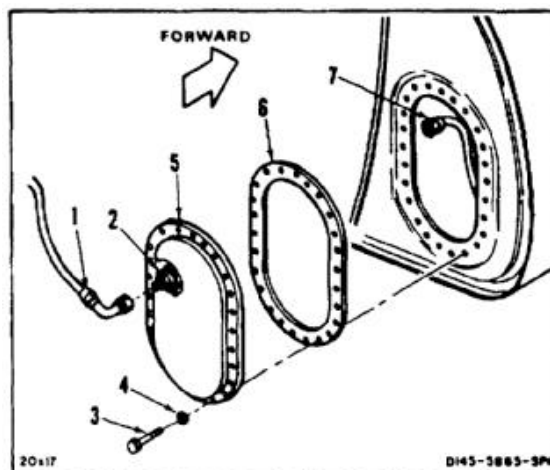
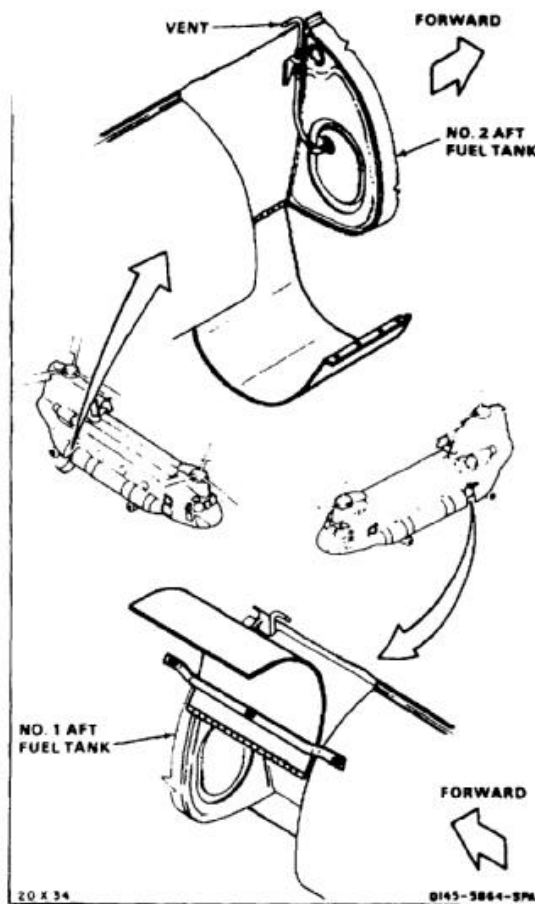

CAUTION

Do not puncture or scratch lining of fuel tank. If lining is broken, fuel penetrates and activates self-sealing layers. Activated layers swell and trap fuel. Activated green spongy material also contaminates fuel system. This makes it necessary to replace fuel tank and flush fuel system.

4. Disconnect hose (7) from valve (8). Plug and remove hose from tank (9).
5. Disconnect tube (10) from valve (8).
6. Remove four bolts (11) and washers (12).
7. Remove valve (8) and adapter (13) from tank (9) as a unit.

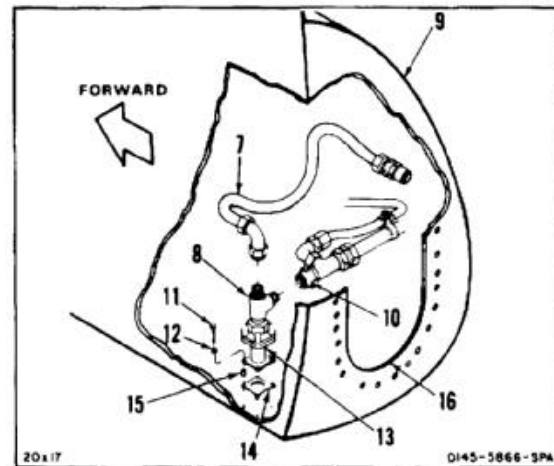

NOTE

Four different types of aft fuel cells are used on the helicopter. Each is interchangeable but has a different assembly between valve adapter and cell. Goodyear cells have four bushings, FPT cells have an adapter plate, and Uniroyal cells have nothing between adapter and cell.

8. Remove shim plate (14) or four bushings (15) from tank (9).
9. Cover access hole (16) in tank (9). Use barrier material (E80) and tape (E388).

10. Remove four bolts (17), washers (18), and adapter (19).
11. Remove gasket (20).

FOLLOW-ON MAINTENANCE:

None

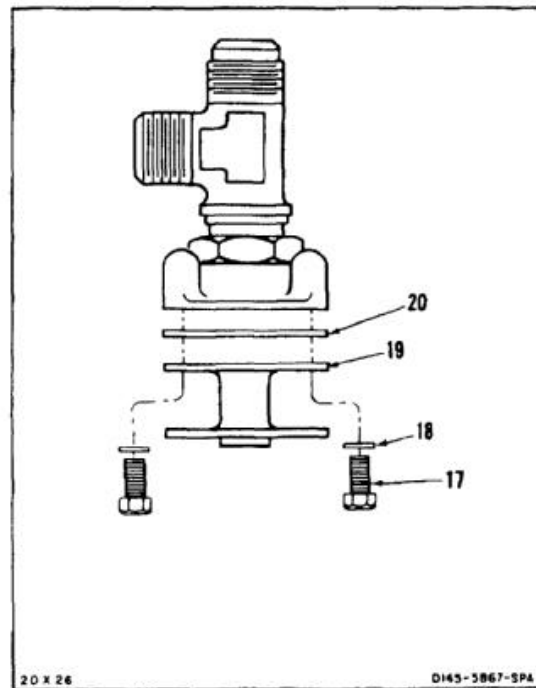

END OF TASK

10-394

INITIAL SETUP

Applicable Configurations:

All

Tools:

Aircraft Mechanic's Tool Kit, NSN 5180-00-323-4692

Materials:

Dry Cleaning Solvent (E162)
Cloths (E135)
Gloves (E186)

Parts:

Gasket

Personnel Required:

Medium Helicopter Repairer
Inspector

References:

Task 10-117
TM 55-1520-240-23P

General Safety Instructions:

WARNING

All regulations and instructions
for handling fuels shall be strictly
observed.

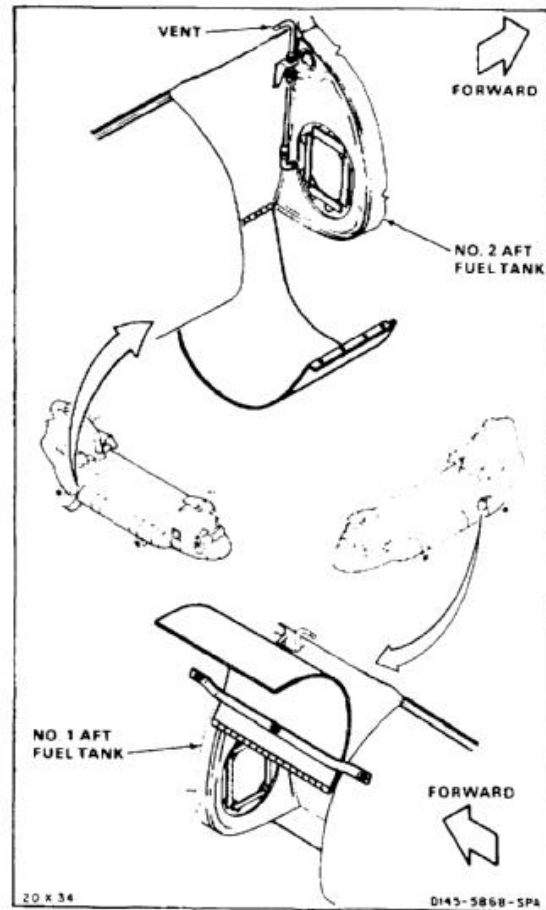

NOTE

Procedure is same to install vent valve on No. 1 or No. 2 aft fuel tank. Installation of No. 2 (right) vent valve is shown here.

1. Position gasket (1) and adapter (2) on vent valve (3). Install four washers (4) and bolts (5).

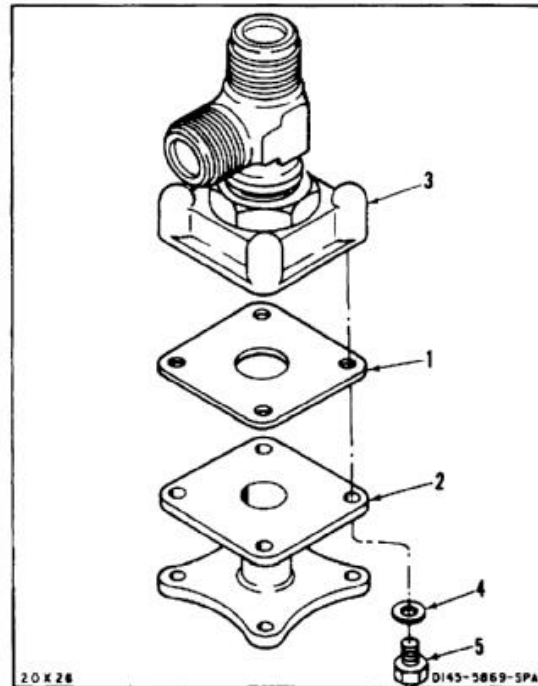

WARNING

Dry cleaning solvent (E162) is flammable and toxic. It can irritate skin and cause burns. Use only in well-ventilated area, away from heat and open flame. In case of contact, immediately flush skin or eyes with water for at least **15 minutes**. Get medical attention for eyes.

- Remove barrier material and tape covering hole (6) in tank (7). Remove tape residue from tank. Use dry cleaning solvent (E162) and cloths (E135). Wear goggles to protect eyes. Wear gloves (E186).

CAUTION

Do not puncture or scratch lining of fuel tank. If lining is broken, fuel penetrates and activates self-sealing layers. Activated layers swell and trap fuel. Activated green spongy material also contaminates fuel system. This makes it necessary to replace fuel tank and flush fuel system.

NOTE

Four different types of aft fuel cells are used on the helicopter. Each is interchangeable but has a different assembly between valve adapter and cell. Goodyear cells have four bushings, FPT cells have an adapter plate, and Uniroyal cells have nothing between adapter and cell.

- Position shim plate (8) or four bushings (9), adapter (10), and valve (2) with port (4) outboard, over vent valve (11), on floor of tank (7).
- Install four washers (12) and bolts (13).
- Connect tube (14) to port (4) of valve (2).
- Remove plug from hose (15). Connect hose to valve (2).

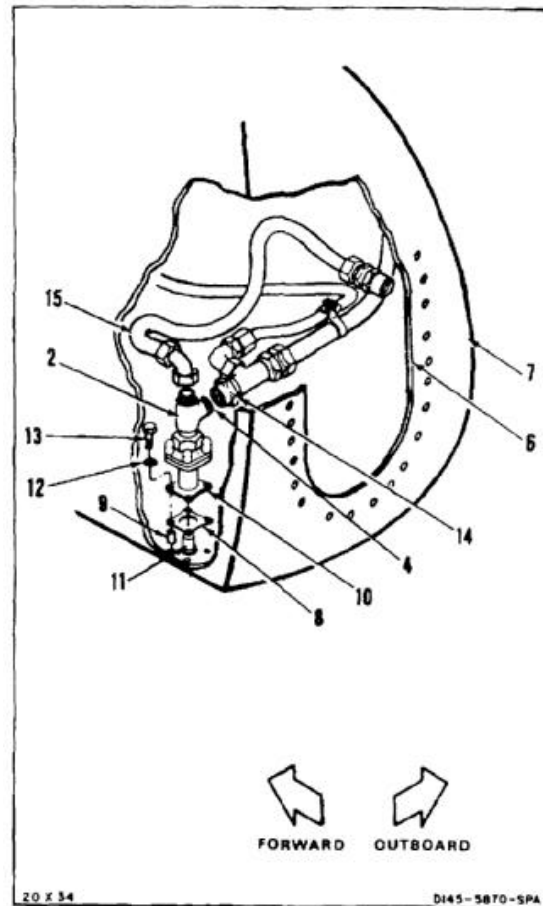
INSPECT

7. Perform vent system pressure test (Task 10-117).
8. Position gasket (16) and door (17) next to access hole (6).
9. Connect vent hose (18) to inside connector of fitting (19).
10. Position gasket (16) and door (17) against tank (7).
11. Install 30 washers (20) and bolts (21).
12. Connect vent hose (22) to fitting (19).

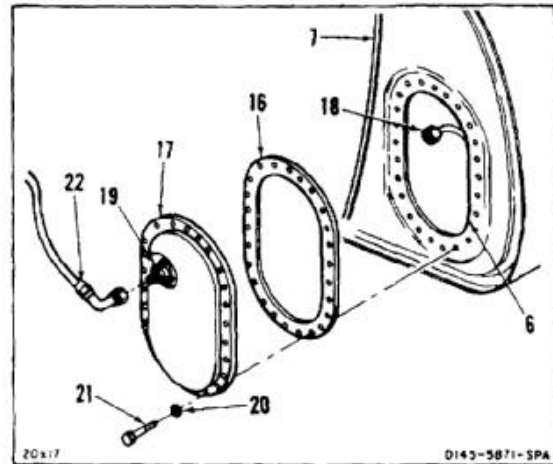
INSPECT**FOLLOW-ON MAINTENANCE:**

- Test aft fuel tank (Task 10-32).
- Perform vent system flow test (Task 10-118).
- Refuel helicopter (Task 1-51).
- Bleed fuel system (Task 10-121).
- Perform operational check of affected fuel system (TM 55-1520-240-T).
- Inspect system for leaks (Task 10-4).
- Install right aft access panel or lower and latch left aft access door (Task 2-188).

END OF TASK

INITIAL SETUP

Applicable Configurations:

All

Tools:

Aircraft Mechanic's Tool Kit, NSN 5180-00-323-4692
 Grounded Container, 2 Gallon or Equivalent

Materials:

Cloth (E135)

Personnel Required:

Medium Helicopter Repairer

Equipment Condition:

- Battery Disconnected (Task 1-39)
- Electrical Power Off
- Helicopter Grounded (Task 1-29)
- Aft Intertank Access Panel Opened (Task 2-185)
- Forward Landing Gear Access Door Opened (Task 2-2)

General Safety Instructions:

WARNING

All regulations and instructions for handling fuels shall be strictly observed.

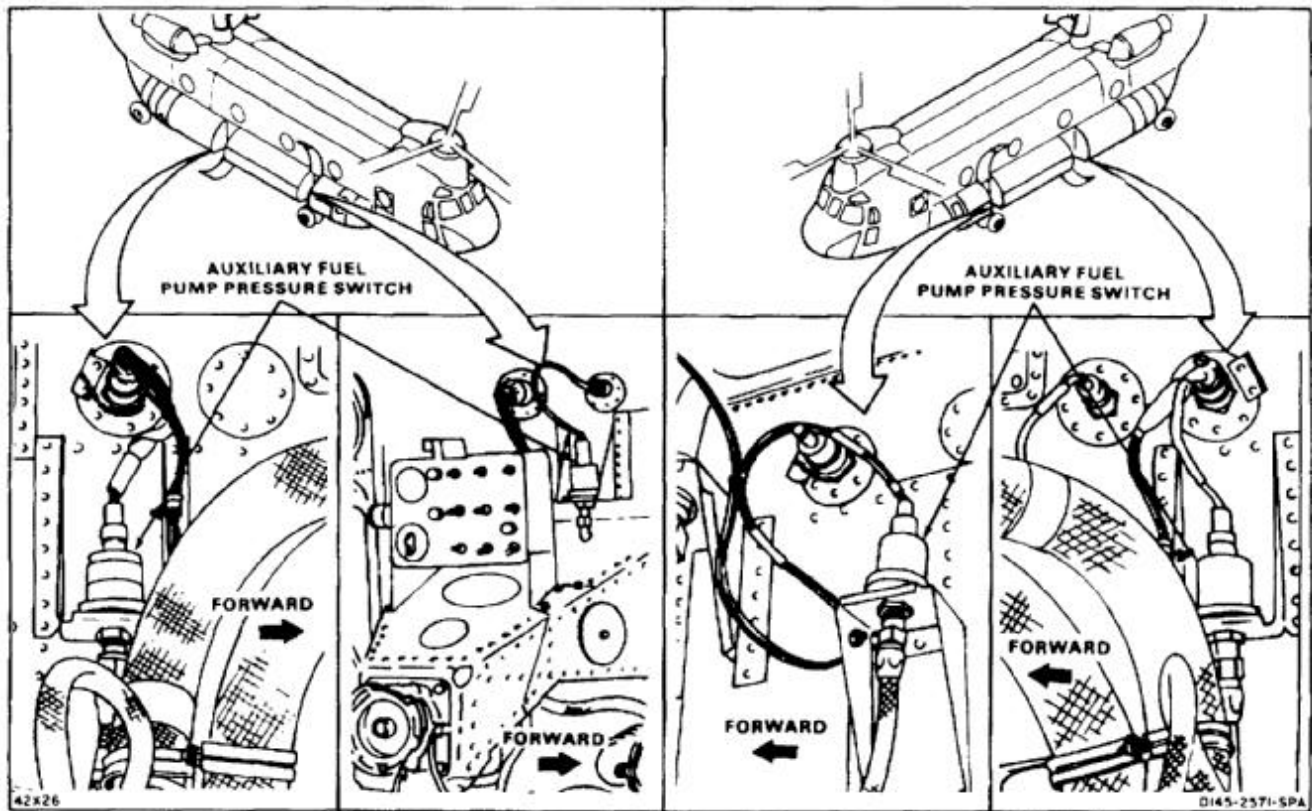

NOTE

There are four auxiliary fuel pump pressure switches in fuel system. Procedure is same for removing any pressure switch.

1. Disconnect electrical connector (1).
2. Disconnect hose (2). Use container for any spilled fuel.
3. Remove nut (3) and washer (4) from pressure switch (5).
4. Remove pressure switch (5).
5. Plug hose (2) and cap switch (5).
6. Clean up any spilled fuel. Use cloths (E135).

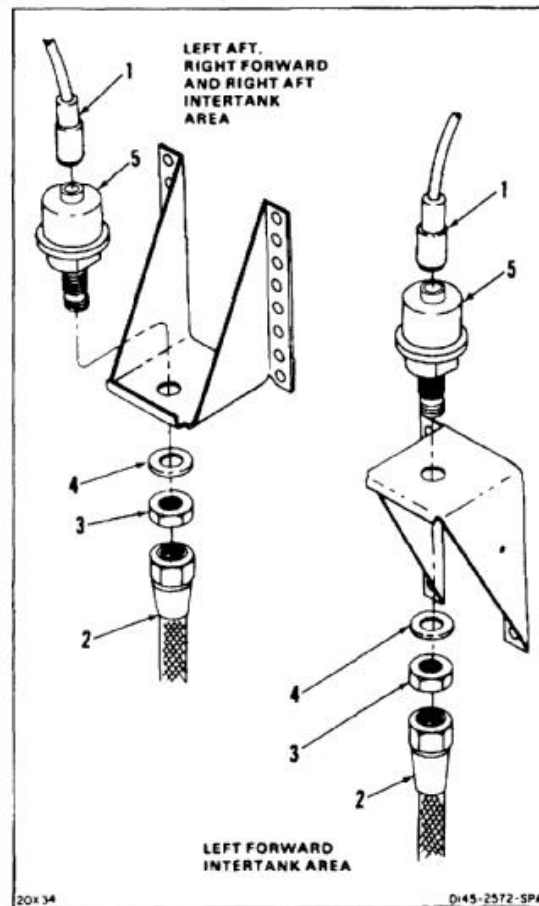
**FOLLOW-ON MAINTENANCE:**

None

END OF TASK

10-400

INITIAL SETUP

Applicable Configurations:

All

Tools:

Aircraft Mechanic's Tool Kit, NSN 51 80-00-323-4692

Materials:

None

Personnel Required:

Medium Helicopter Repairer
Inspector

References:

TM 55-1520-240-23P

General Safety Instructions:

WARNING

All regulations and instructions for handling fuels shall be strictly observed.

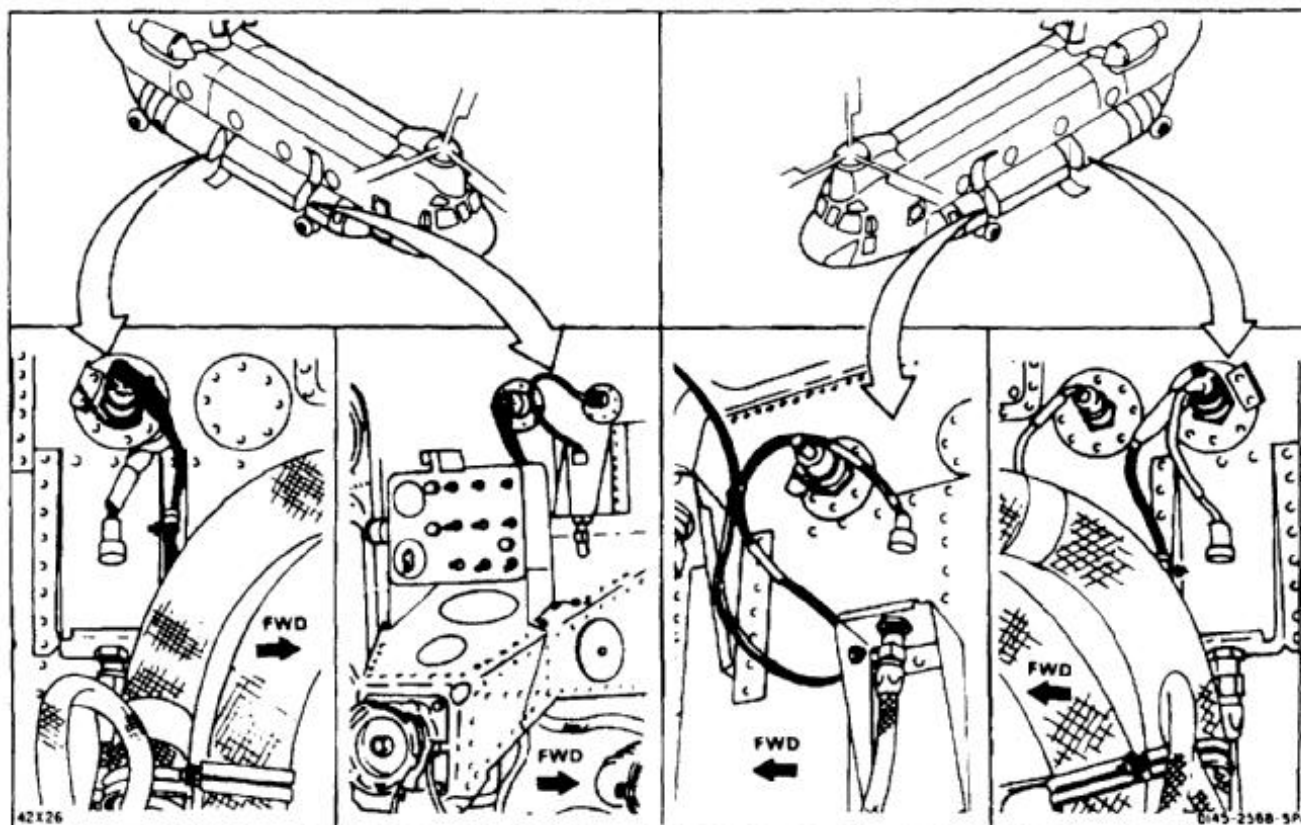

NOTE

There are four auxiliary fuel pump pressure switches in fuel system. Procedure is same for installing any pressure switch.

1. Remove cap and plug from pressure switch (1) and hose (2).
2. Position pressure switch (1) on bracket (3).
3. Install washer (4) and nut (5) on pressure switch (1).
4. Connect hose (2).
5. Connect electrical connector (6).

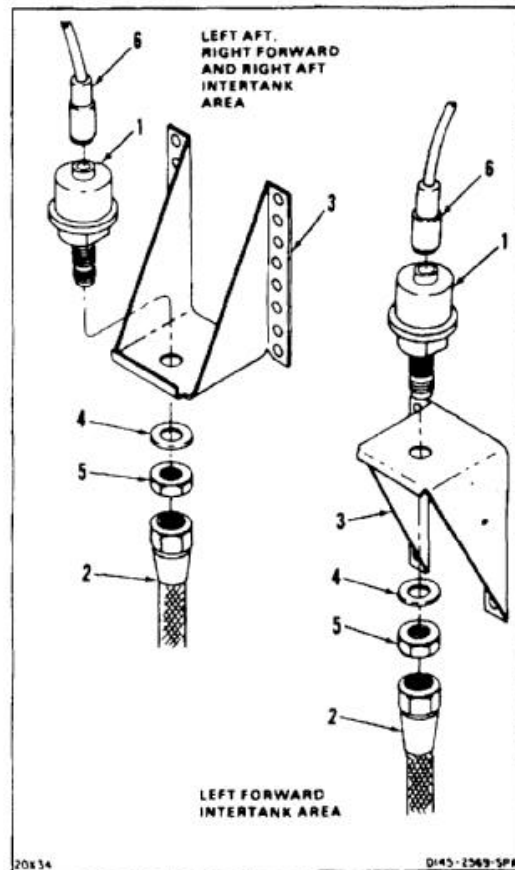
INSPECT**FOLLOW-ON MAINTENANCE:**

- Perform operational check of fuel system (TM 55-1520-240-T).
- Close aft intertank panel (Task 2-188).
- Close forward landing gear access door (Task 2-2).

END OF TASK

10-402

INITIAL SETUP

Applicable Configurations:

All

Tools:

Aircraft Mechanic's Tool Kit, NSN 5180-00-323-4692
 Strap Wrench
 Grounded Container, 14 Quart or Equivalent

Materials:

Cloths (E135)

Personnel Required:

Medium Helicopter Repairer

Equipment Condition:

Battery Disconnect (Task 1-39)
 Electrical Power Off
 Helicopter Grounded (Task 1-29)
 Forward Right Landing Gear Access Panel Removed
 (Task 2-180)

General Safety Instructions:**WARNING**

All regulations and instructions
 for handling fuels shall be strictly
 observed.

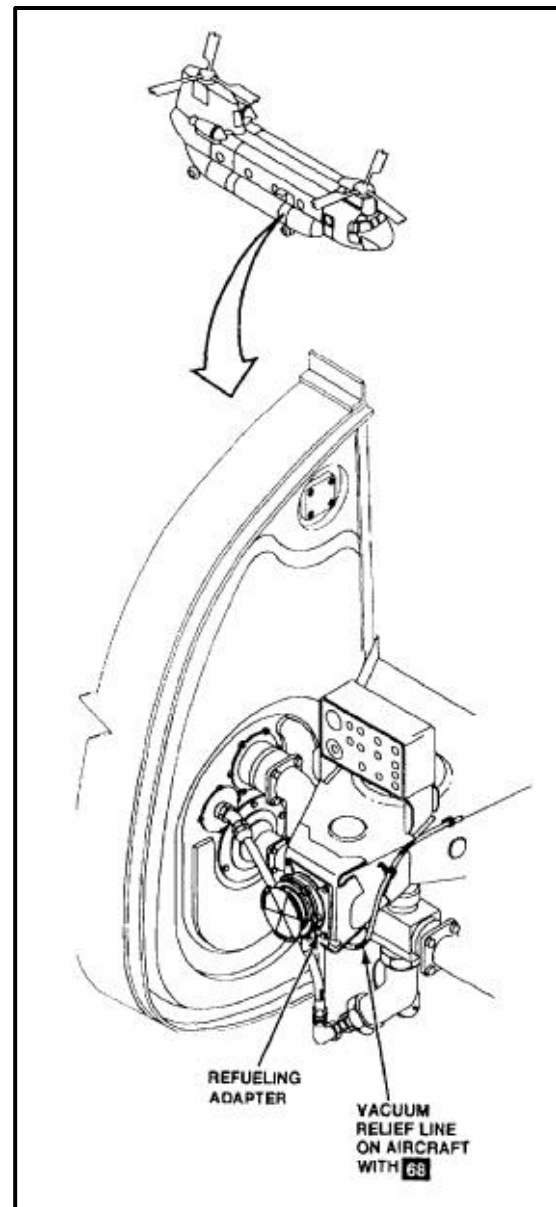

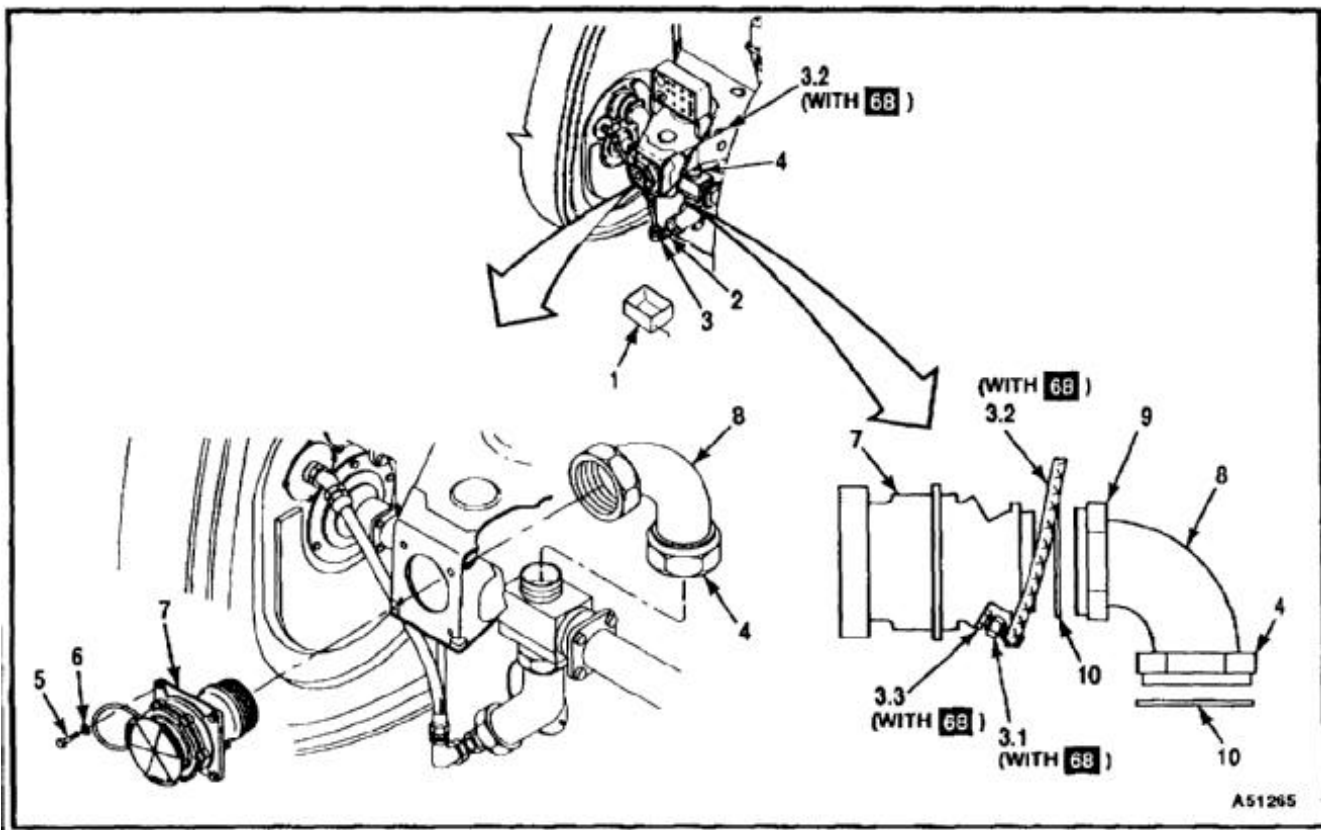

1. Position grounded container (1) under drain fitting (2).
2. Disconnect hose elbow (3) from the drain fitting (2). Collect spilled fuel in container (1).
3. Connect fitting (3) to drain fitting (2).
- 3.1. On aircraft with **68**, disconnect elbow (3.1) of vacuum relief line (3.2), from nipple (3.3) on refueling adapter (7).
4. Disconnect ring nut (4).
5. Remove four bolts (5) and washers (6) from adapter (7).
6. Remove adapter (7) and elbow (8) as an assembly through the opening in the adapter support.
7. Remove elbow (3) from adapter (7) by disconnecting ring nut (9).
8. Remove packing (10) at ring nuts (4) and (9).
9. Wipe up any spilled fuel. Use cloths (E135).
10. Remove container (1).

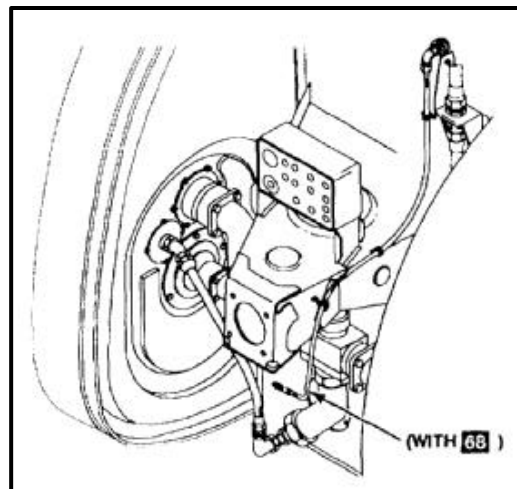
**FOLLOW-ON MAINTENANCE:**

None

END OF TASK

10-404

10-87.1 DISASSEMBLE PRESSURE REFUELING ADAPTER (2650266)

10-87.1

INITIAL SETUP**Applicable Configurations:**

All

Tools:

Aircraft Mechanic's Tool Kit, NSN 5180-00-323-4692

Materials:

None

Personnel Required:

Medium Helicopter Repairer

Equipment Condition:

Off Helicopter Task

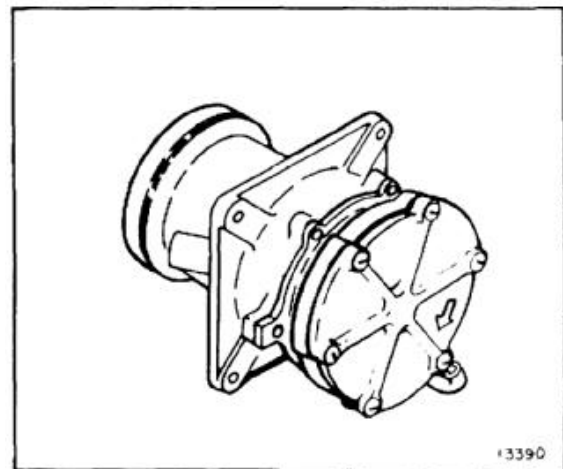

1. Remove cap assembly (1) from adapter (2) and body (3) by pushing down cap while turning counterclockwise.
2. Remove six screws (4) and ring (5) from cover (6). Remove chain (6.1) from pin (6.2).
3. Remove poppet assembly (7), wave washer (8), flat washer (9), and backup (10) from cover (6).
4. Remove packing (11) from backup (10).

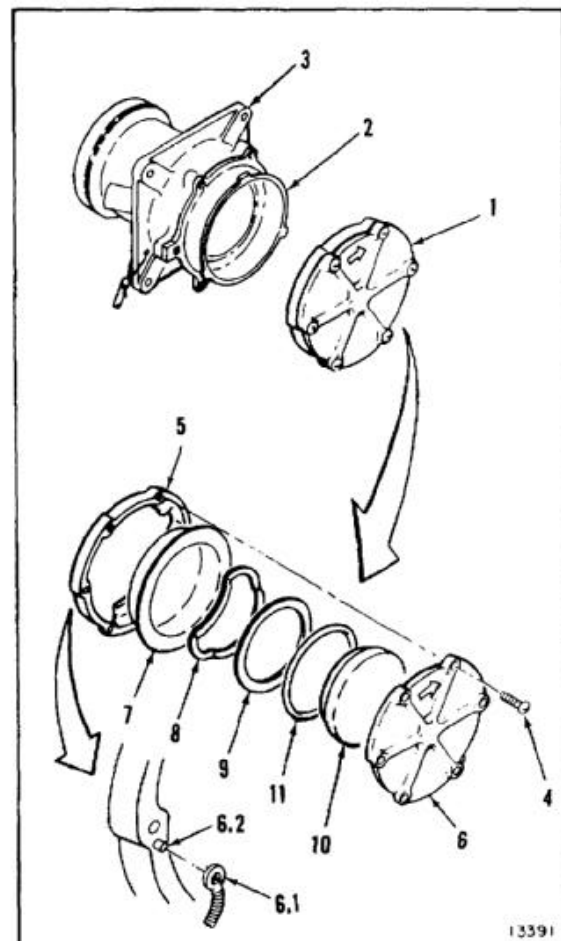

5. Remove six screws (12) and adapter (2) from body (3).
6. Remove packing (13) from adapter (2).
7. On aircraft with **68**, remove nipple (14) and packing (15) from port (16) in adapter body (3).

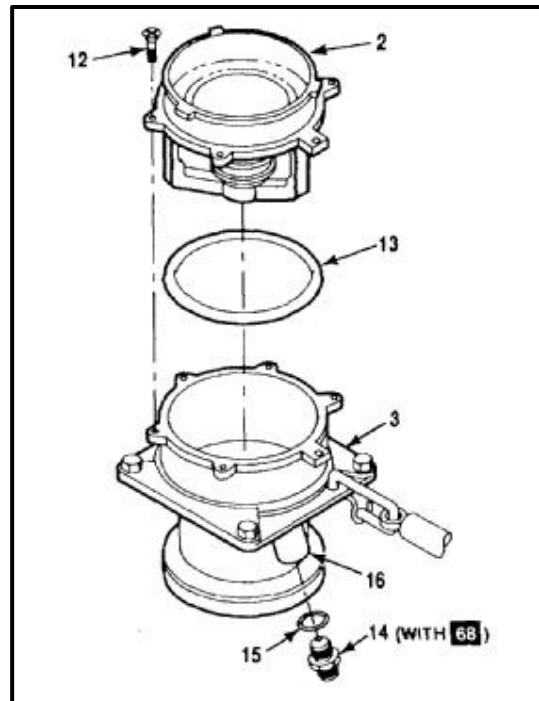
**FOLLOW-ON MAINTENANCE:**

None

END OF TASK

10-406

INITIAL SETUP**Applicable Configurations:**

All

Tools:

Aircraft Mechanic's Tool Kit, NSN 5180-00-323-4692

Materials:

None

Personnel Required:

Medium Helicopter Repairer

Equipment Condition:

Off Helicopter Task

1. Install packing (1) on adapter (2).
2. Line up square tabs and install adapter (2) in body (3) using six screws (4).

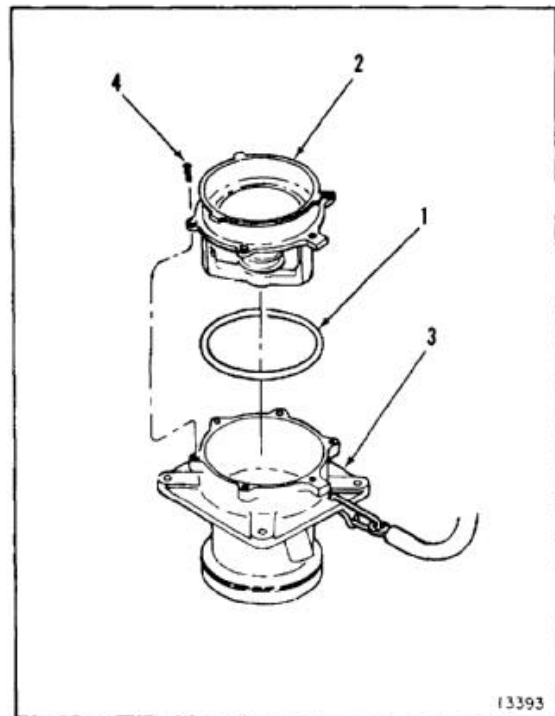

13393

3. Install packing (4) on backup (5).
4. Install backup (5), flat washer (6), wave washer (7) and poppet assembly (8) in cover (9).
5. Install chain (9.1) on pin (9.2) of ring (10).
6. Align hole in cover (9) with pin (9.2). Install cover on ring (10) with six screws (11).
7. Install cover assembly (12) in adapter (2) and body (3). Turn cover clockwise to lock.
8. On aircraft with **68**, install packing (13) and nipple (14) in port (15) of body (3).

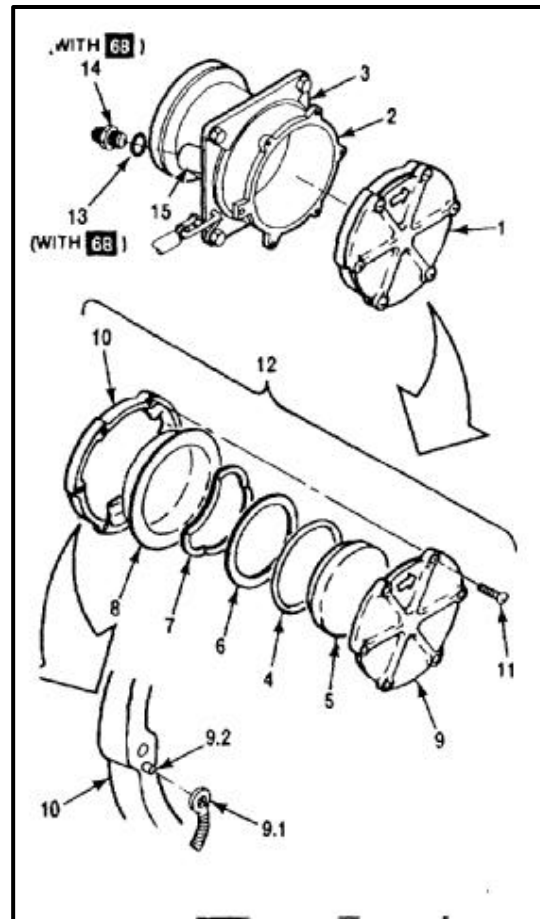

FOLLOW-ON MAINTENANCE:

- Install pressure refueling adapter (Task 10-88).
 Perform single point refueling (Task 1-51).

END OF TASK

10-87.3 REPLACE PRESSURE REFUELING VACUUM RELIEF CHECK VALVE

10-87.3

INITIAL SETUP**Applicable Configurations:**Aircraft With **68****Tools:**

Aircraft Mechanic's Tool Kit, NSN 51 80-00-323-4692

Materials:

None

Personnel Required:

Medium Helicopter Repairer

References:

TM 55-1520-240-23P

Equipment Condition:

Battery Disconnected (Task 1-39)

Electric Power Off

Hydraulic Power Off

Helicopter Grounded (Task 1-29)

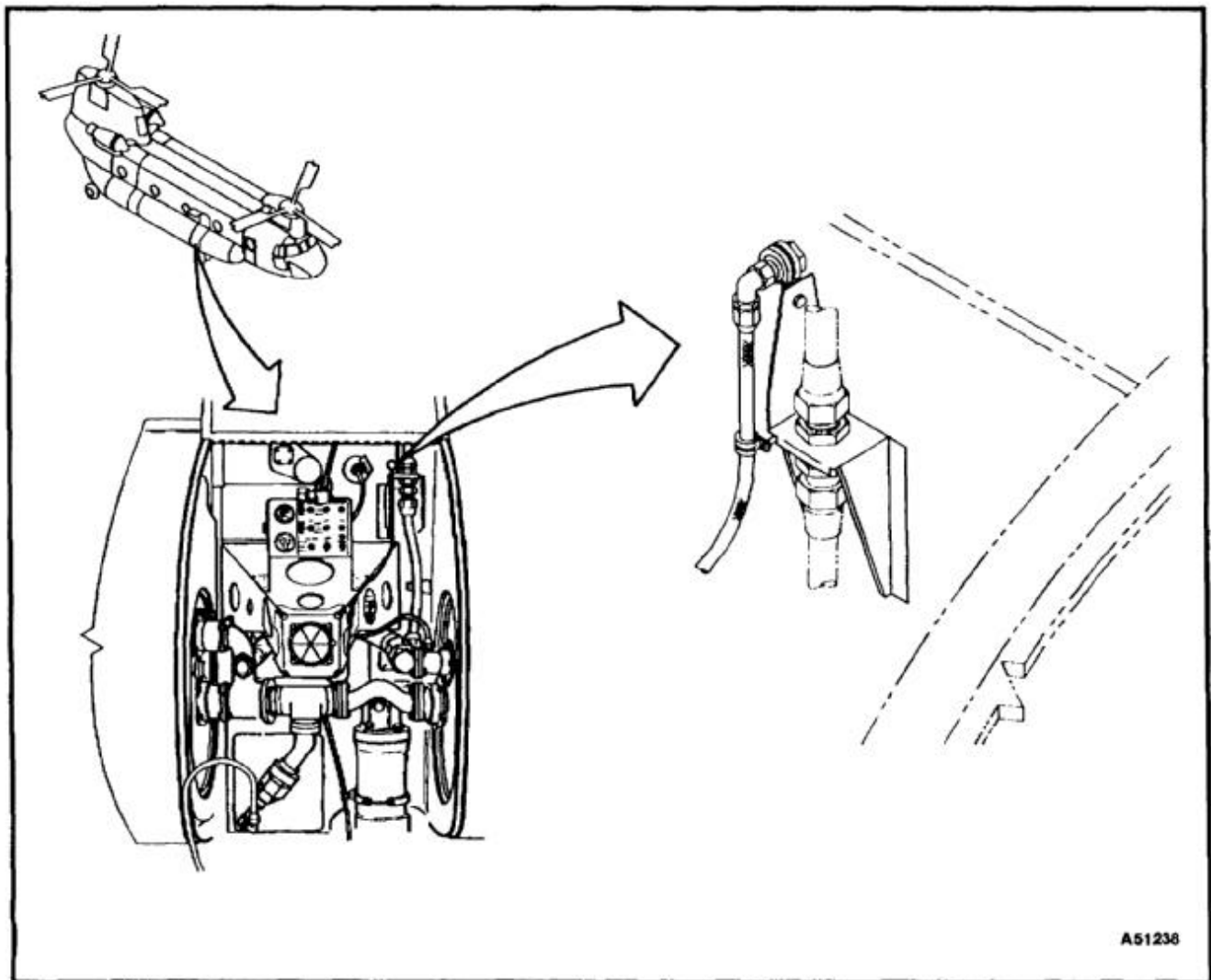
Right Forward Landing Gear Access Door Open
(Task 2-2)

VALVE REMOVAL

1. Disconnect hose assembly elbow (1) from valve (2).
2. Remove clamp (3) and valve (2) from bracket (4) by removing nut (5), washer (6), and screw (7).
3. Remove clamp from around valve.

VALVE INSTALLATION

4. Place valve (2) in clamp (3).

5. Position valve (2) and clamp (3) on bracket (4).
6. Install screw (7) washer (6), and nut (5), through clamp (3) and bracket (4).
7. Connect hose assembly elbow (1) to valve (2).

FOLLOW-ON MAINTENANCE:

Close forward right landing gear access door (Task 2-181).

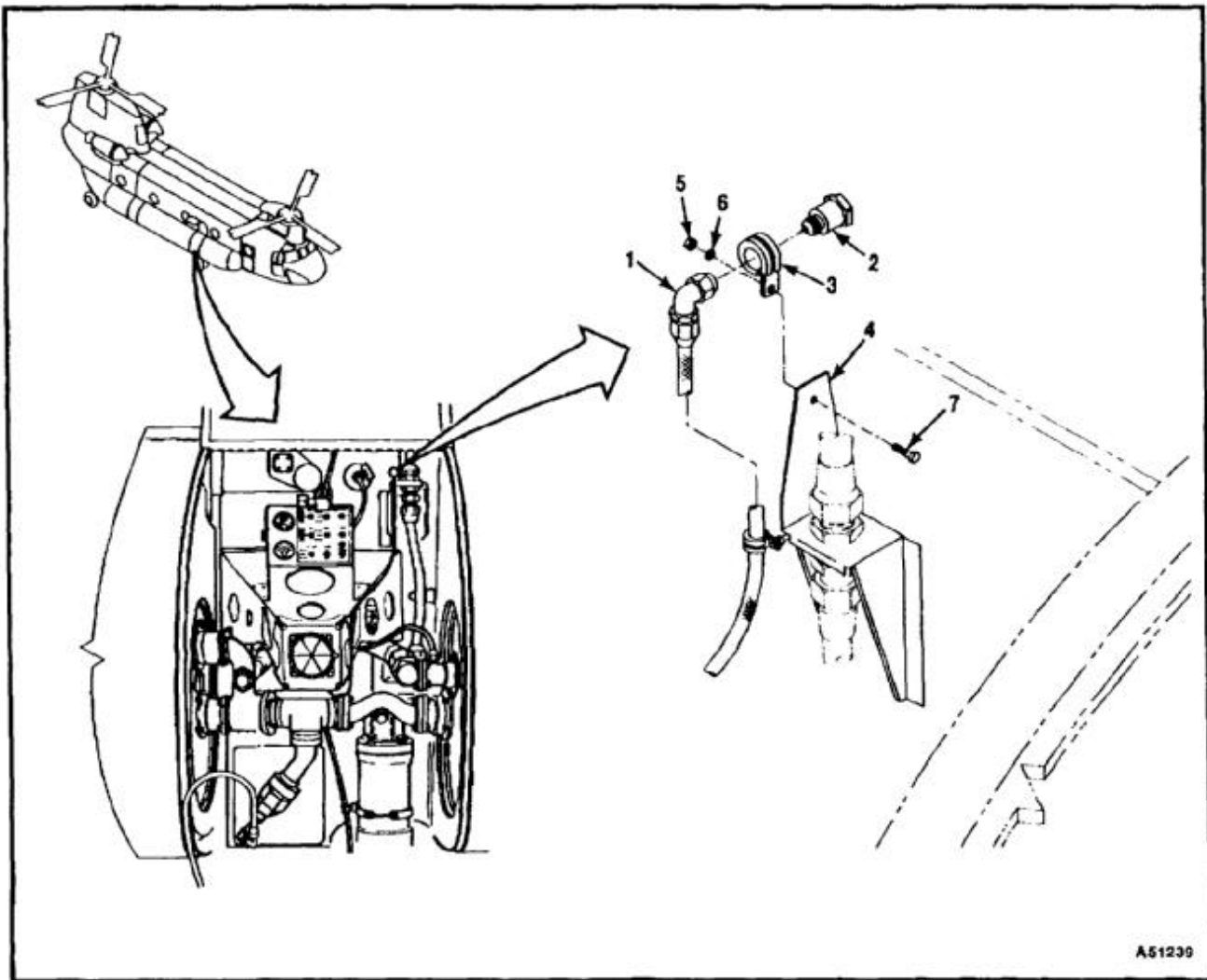

END OF TASK

INITIAL SETUP

Applicable Configurations:

All

Tools:

Aircraft Mechanic's Tool Kit, NSN 51 80-00-323-4692
Strap Wrench

Materials:

Petrolatum (E274)
Lockwire (E233)

Parts:

Packings

Personnel Required:

Medium Helicopter Repairer
Inspector

General Safety Instructions:**WARNING**

All regulations and instructions
for handling fuels shall be strictly
observed.

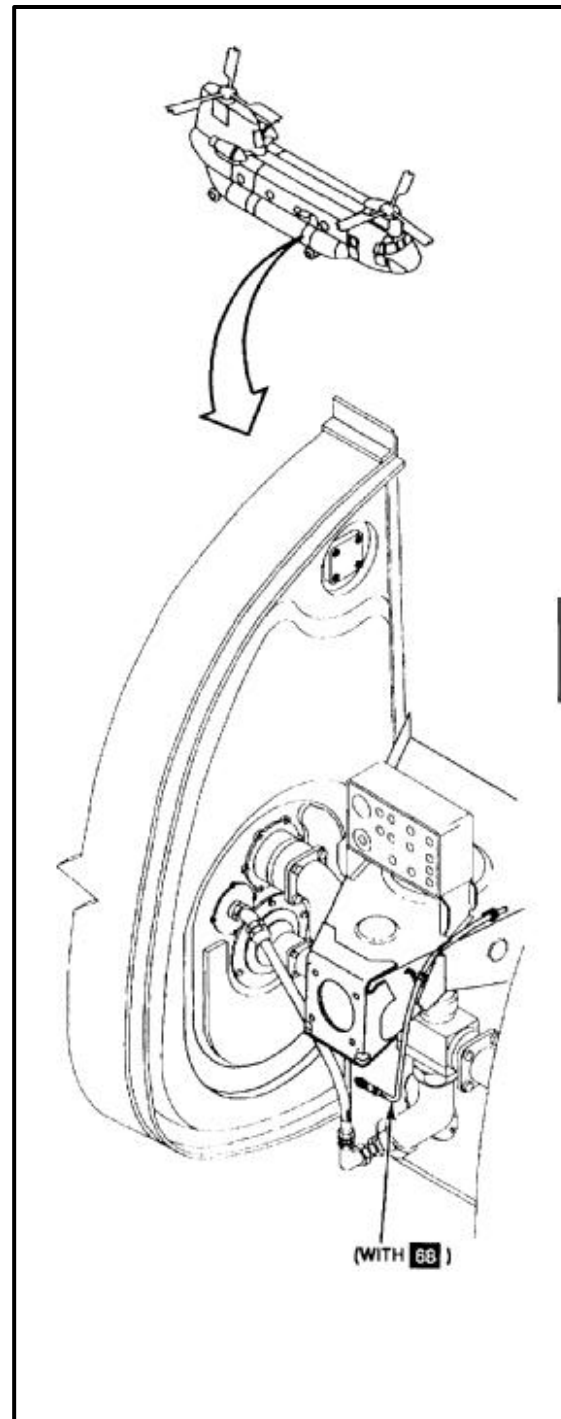

1. Lubricate packings (2). Use petrolatum (E274). Install a packing at each ring nut (3) and (5).



Do not damage packing when installing adapter.

2. Connect adapter (1) to elbow (4) with ring nut (3). Make sure that the arrow on the elbow points away and down from the adapter. On aircraft with **68**, nipple (4.1) in port of adapter shall also be pointing down. Tighten the ring nut.
3. Install the assembled adapter (1) and elbow (4) through the support. Align the bolt holes in the adapter and support and the ring nut, (5) with the opening in the cross fitting (8).
4. Connect ring nut (5) to cross fitting (8). Tighten ring nut.
5. Install four bolts (6) and washers (7).
6. Lockwire ring nuts (3) and (5) together. Use lockwire (E233).

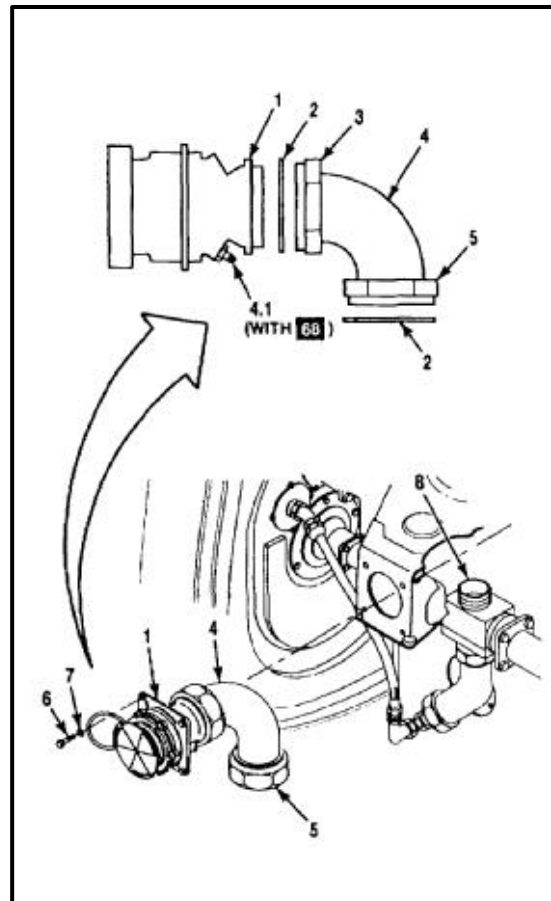

7. On aircraft with **68**, connect elbow (9) of vacuum relief vent line (10), to nipple (4.1) in adapter (1).

INSPECT

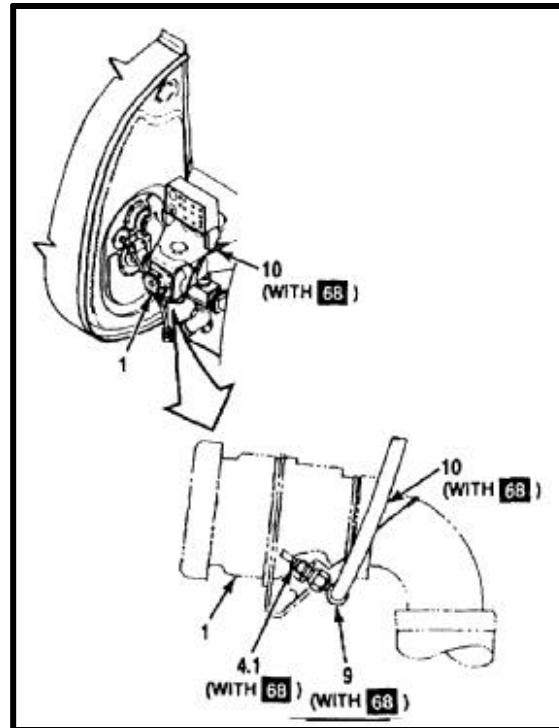

FOLLOW-ON MAINTENANCE:

- Refuel helicopter (Task 1-51).
- Bleed fuel system (Task 10-121).
- Check refueling adapter for leaks (Task 10-4).
- Install forward right landing gear access panel (Task 2-181).

END OF TASK

INITIAL SETUP

Applicable Configurations:

Without **82**

Tools:

Aircraft Mechanic's Tool Kit, NSN 5180-00-323-4692

Materials:

- Cloths (E135)
- Barrier Material (E80)
- Tape (E388)

Personnel Required:

Medium Helicopter Repairer (2)

Equipment Condition:

- Battery Disconnected (Task 1-39)
- Electrical Power Off
- Helicopter Grounded (Task 1-29)
- Forward Right and Left Landing Gear Access Door Open (Task 2-2)
- Three Floor Panels Removed Between Sta. 120 and 280 (Task 2-204)

General Safety Instructions:

WARNING

All regulations and instructions for handling fuels shall be strictly observed.

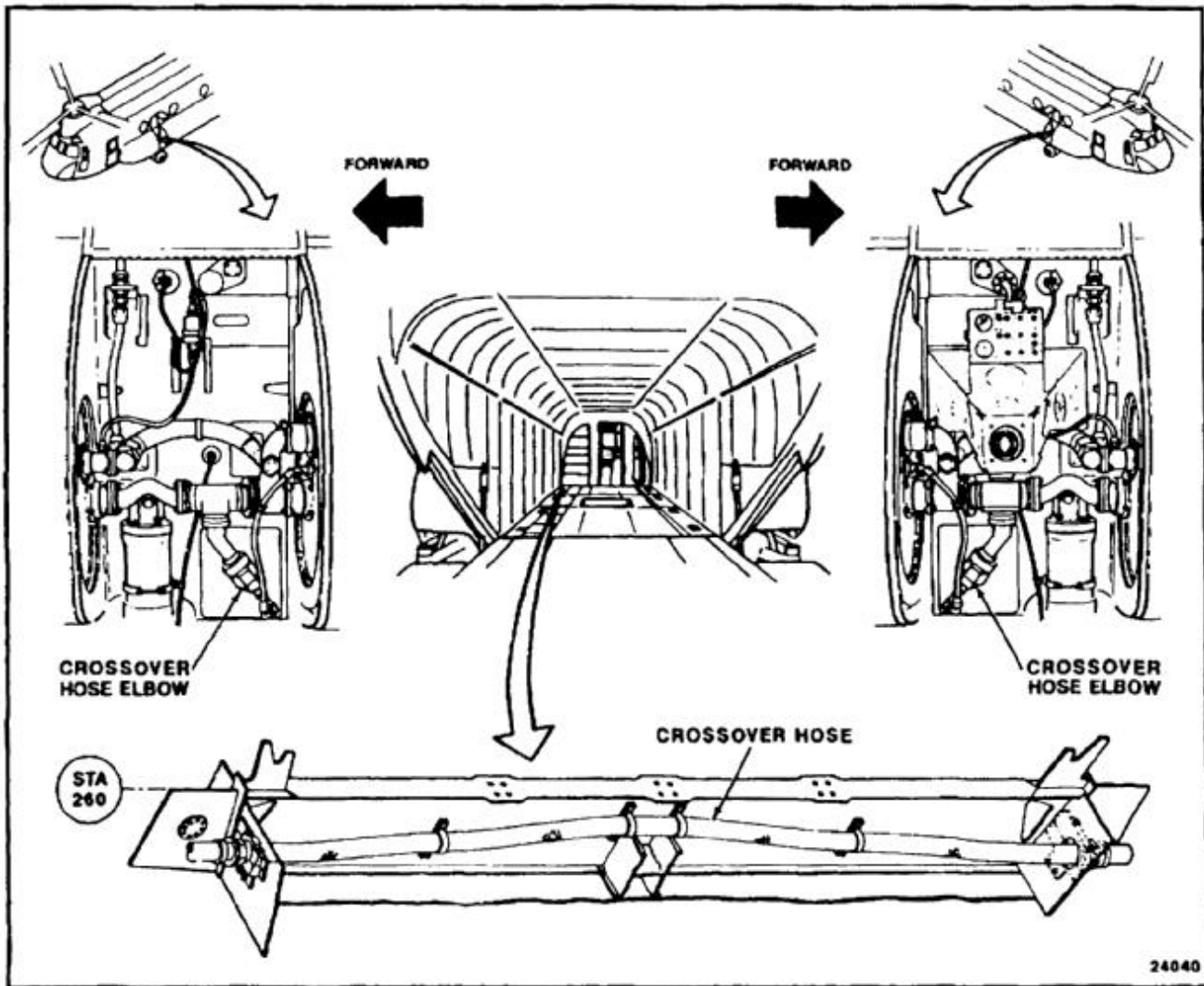

NOTE

The procedure for removing the crossover tube from the right and left crossover tube elbow connections are the same. The left side is described.

1. Working in the landing gear box remove lockwire and loosen ring nut (1) on elbow (2) and ring nut (3) on tee (4). Remove elbow.
2. Cover hole in tee (4) with barrier material (E80) and tape (E388).
3. Place a container underneath crossover hose elbow (5) to collect any residual fuel. Loosen nut (6) on hose assembly (7).
4. Remove hose assembly (7) from crossover hose elbow (5). Cap hose assembly and move out of the way.
5. Remove six bolts (8) and sealing washers (9) from crossover hose elbow (5). Discard six sealing washers.
6. Remove crossover hose elbow (5), preformed packing (10) and gasket (11) from sleeve (12).
7. Remove 26 bolts (13) and sealing washers (14) from access cover (15). Discard 26 sealing washers. Remove access cover.

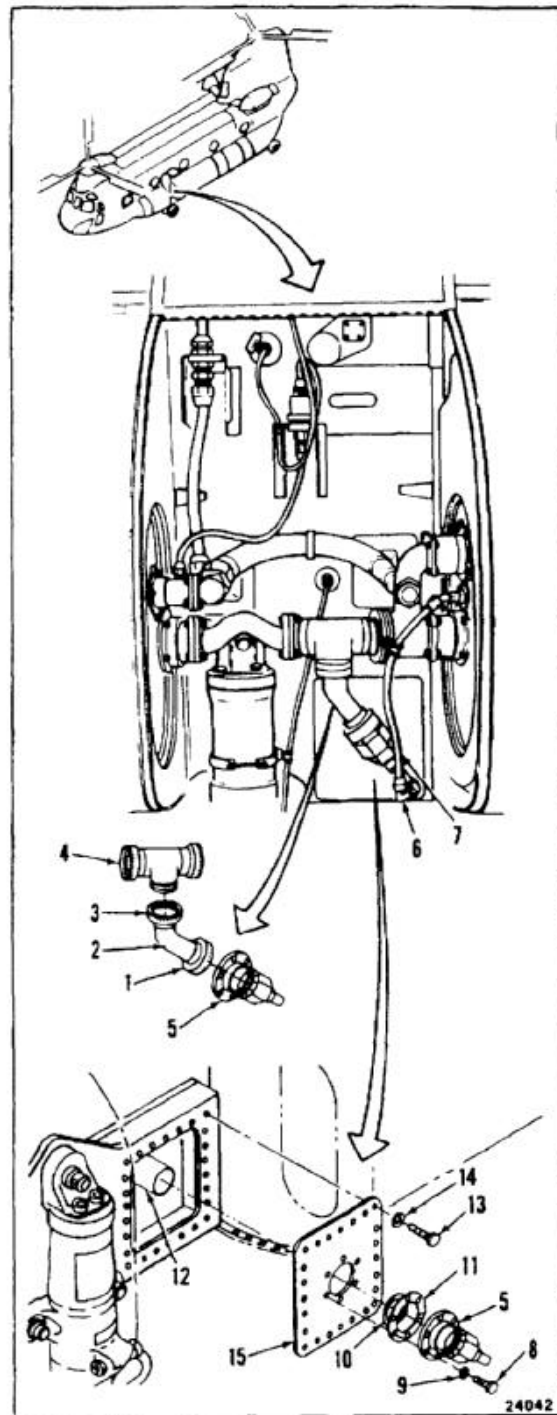

8. Remove three bolts (16) washers (17) and two nuts (18) from hose collar assembly (19).
9. Remove hose collar assembly halves (19) from crossover hose (5).
10. Remove lockwire and loosen ring nut (20) on cross over hose (5). Remove crossover hose from sleeve (12).
11. Working under the floor at sta. 260 remove four clamps (21) and associated hardware from crossover hose (5).
12. Remove crossover hose (5) from aircraft.
13. Clean up any spilled fuel with cloth (E135).

FOLLOW-ON MAINTENANCE:

None

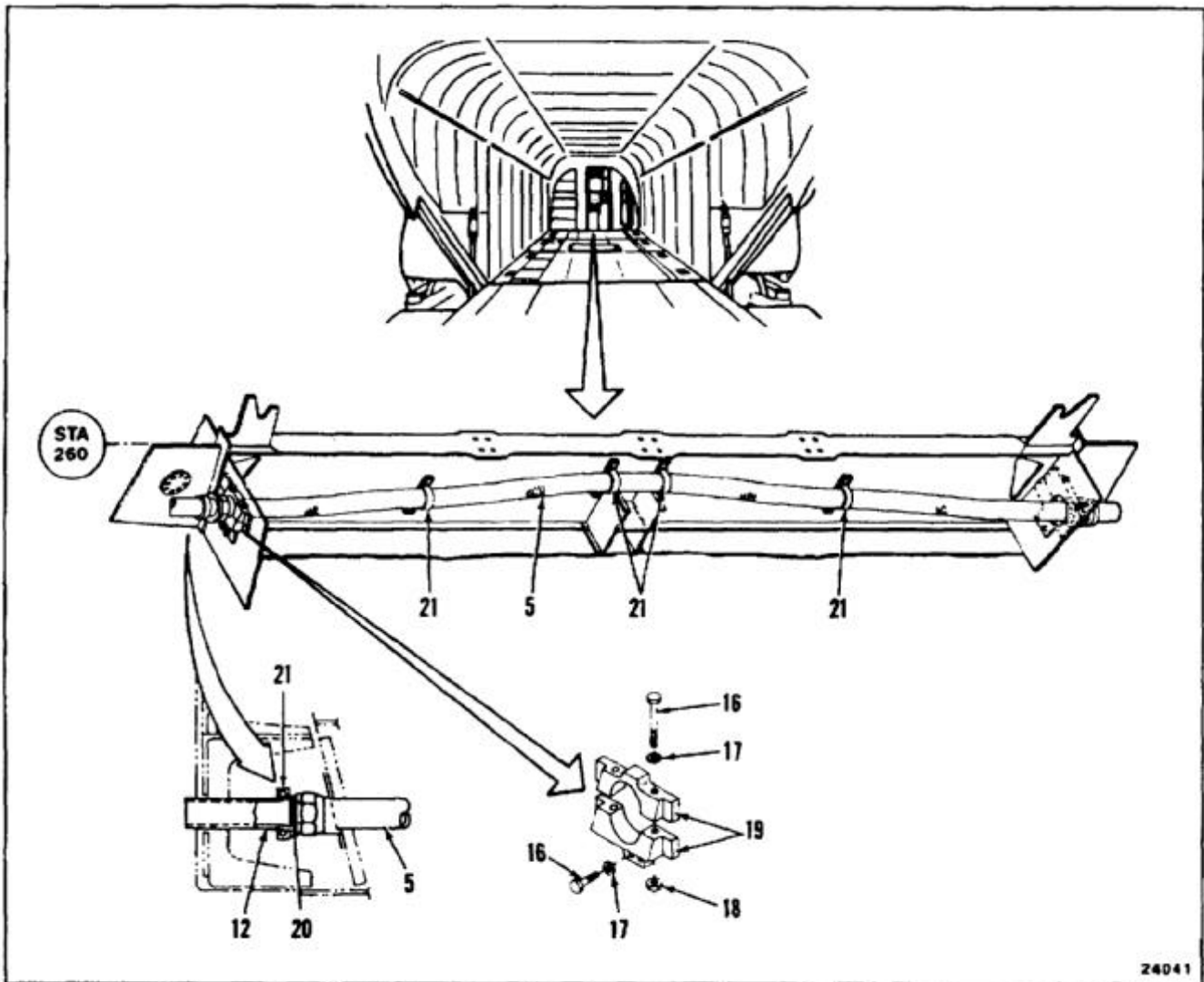

24041

END OF TASK

10-88.2 REMOVE CROSSOVER HOSE

10-88.2

INITIAL SETUP

Applicable Configurations:

With 82

Tools:

Aircraft Mechanic's Tool Kit, NSN 5180-00-323-4692

Materials:

- Cloths (E135)
- Barrier Material (E80)
- Tape (E388)

Personnel Required:

Medium Helicopter Repairer (2)

Equipment Condition:

- Battery Disconnected (Task 1-39)
- Electrical Power Off
- Helicopter Grounded (Task 1-29)
- Forward Right and Left Landing Gear Access Door Open (Task 2-2)
- Three Floor Panels Removed Between Sta. 120 and 280 (Task 2-204)

General Safety Instructions:

WARNING

All regulations and instructions for handling fuels shall be strictly observed.

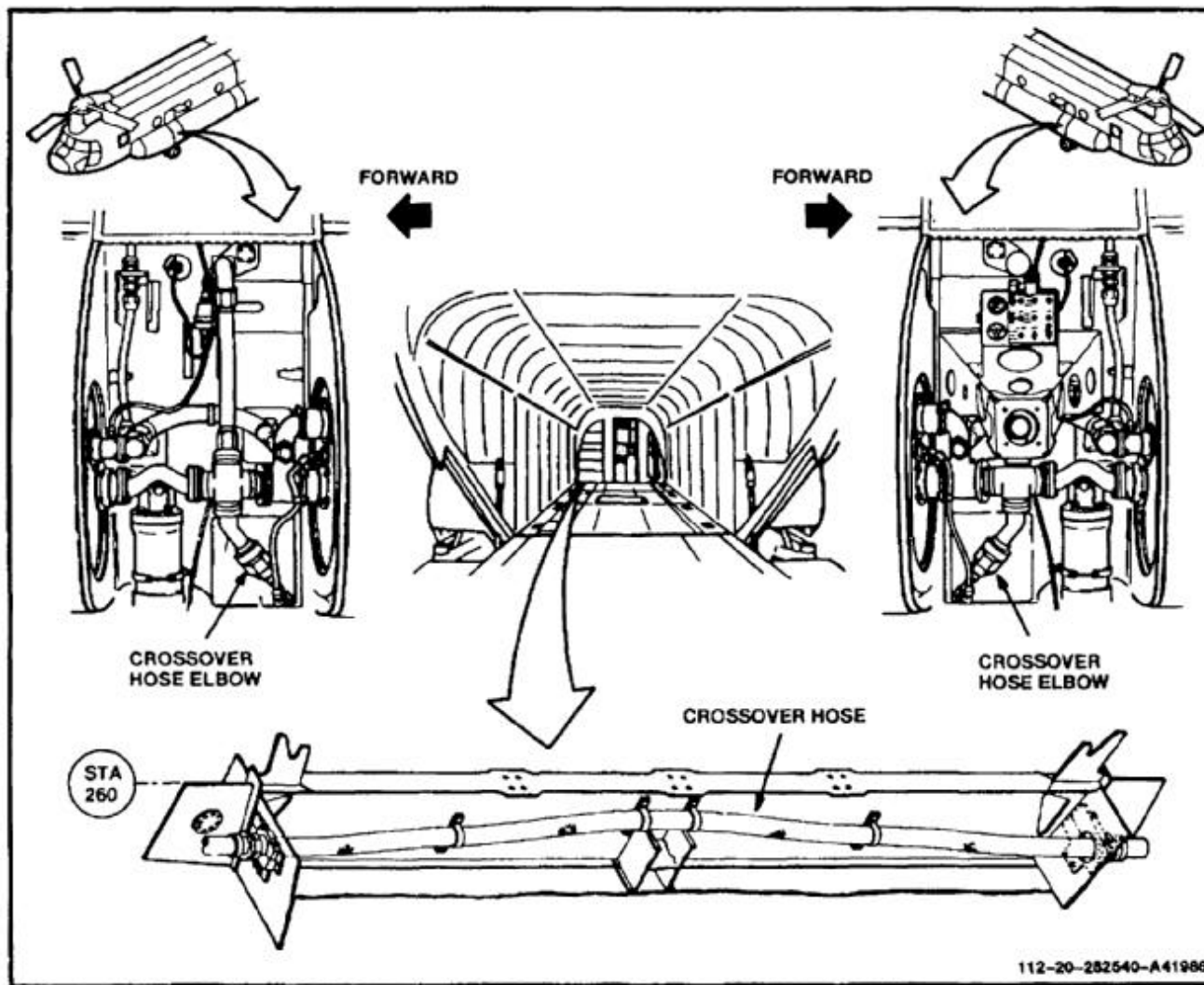

NOTE

The procedure for removing the crossover tube from the right and left crossover tube elbow connections is similar. The left side is described.

1. Working in the landing gear box, remove lockwire and loosen ring nut (1) on elbow (2) and ring nut (3) on tee (4). Remove elbow.
2. Cover the hole in tee (4) with barrier material (E80) and tape (E388).
3. Place a container underneath crossover hose elbow (5) to collect any residual fuel. Loosen nut (6) on hose assembly (7).
4. Remove hose assembly (7) from crossover hose elbow (5). Cap hose assembly and move out of the way.
5. Remove six bolts (8) and sealing washers (9) from crossover hose elbow (5). Discard six sealing washers.
6. Remove crossover hose elbow (5), preformed packing (10), and gasket (11) from sleeve (12).
7. Remove 26 bolts (13) and sealing washers (14) from access cover (15). Discard 26 sealing washers. Remove access cover.

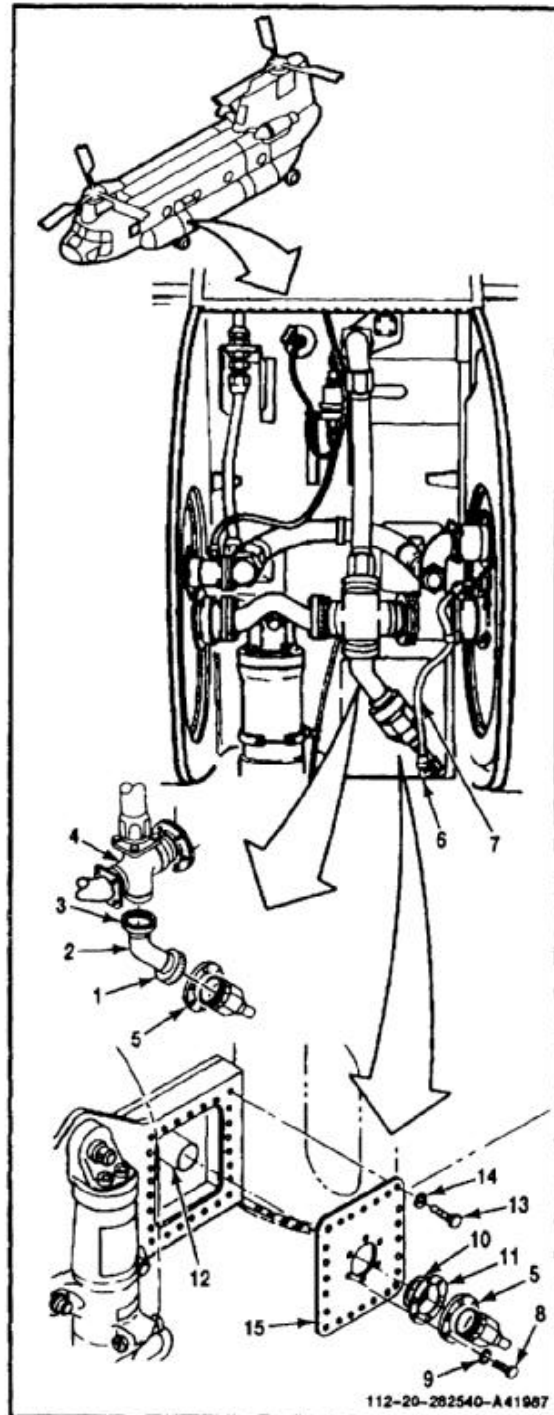

10-88.2 REMOVE CROSSOVER HOSE (Continued)

10-88.2

- 8. Remove three bolts (16), washers (17), and two nuts (18) from hose collar assembly (19).
- 9. Remove hose collar assembly halves (19) from crossover hose (5).
- 10. Remove lockwire and loosen ring nut (20) on crossover hose (5). Remove crossover hose from sleeve (12).
- 11. Working under the floor at sta. 260, remove four clamps (21) and associated hardware from crossover hose (5).
- 12. Remove crossover hose (5) from aircraft.
- 13. Clean up any spilled fuel with cloth (E135).

FOLLOW-ON MAINTENANCE:

None

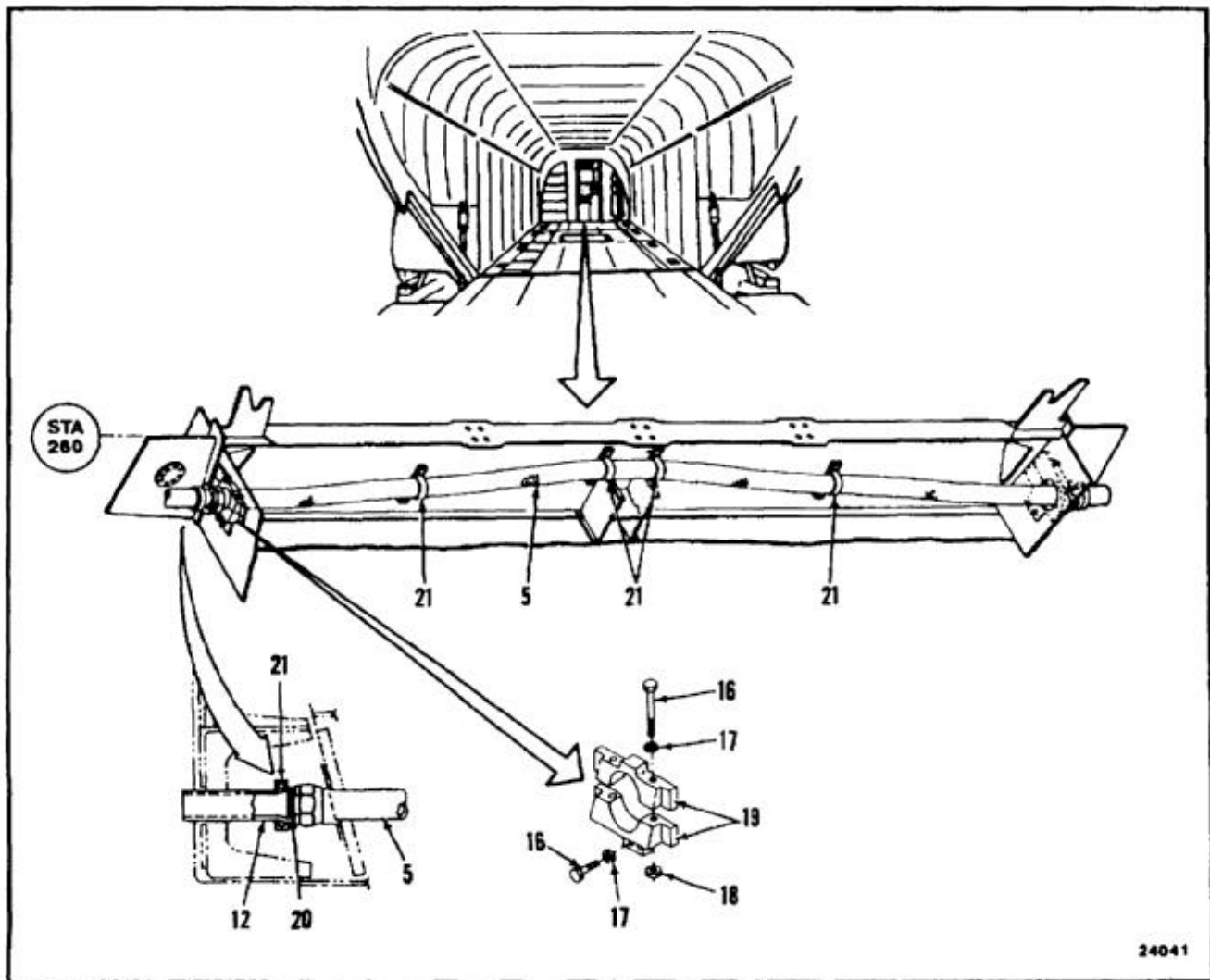

END OF TASK

INITIAL SETUP

Applicable Configurations:

Without **82**

Tools:

Aircraft Mechanic's Tool Kit, NSN 5180-00-323-4692

Materials:

- Lockwire (E233)
- Dry Cleaning Solvent (E162)
- Gloves (E186)

Personnel Required:

- Medium Helicopter Repairer (2)
- Inspector

General Safety Instructions:

WARNING

All regulations and instructions for handling fuels shall be strictly observed.

WARNING

Dry cleaning solvent (E162) is flammable and toxic. It can irritate skin and cause burns. Use only in well-ventilated area, away from heat and open flame. In case of contact, immediately flush skin or eyes with water for at least **15 minutes**. Get medical attention for eyes.

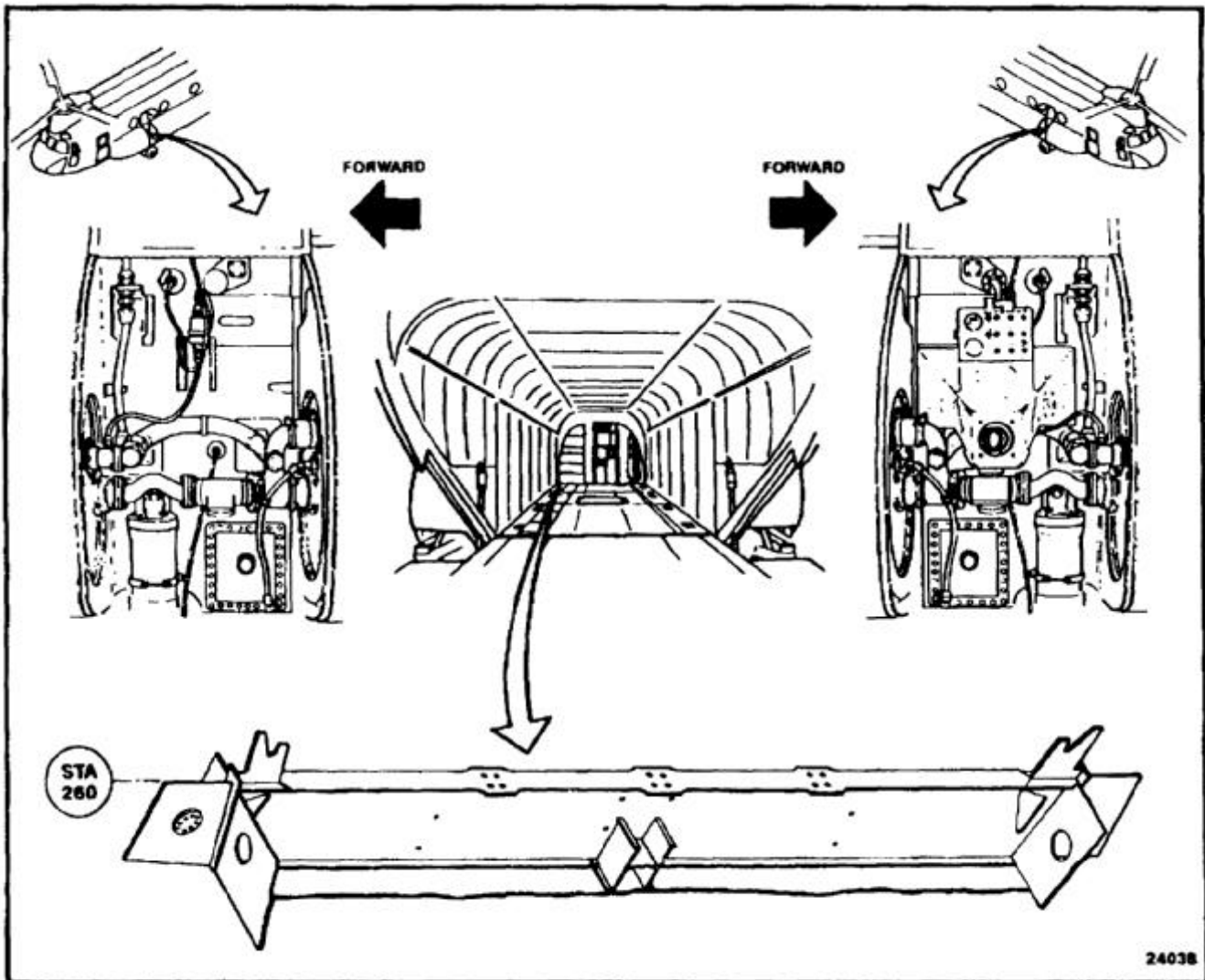

NOTE

The procedures for installing the crossover tube to the right and left crossover tube elbow connections are the same. The left side is described.

1. Working under the floor at sta. 260, install the crossover hose (1) loosely with four clamps (2) and associated hardware. Center the hose laterally.
2. Install crossover hose (1) on sleeve (3). Hand tighten ring nut (4).
3. Install hose collar assembly halves (5) on crossover hose (1).
4. Install and tighten three bolts (6), three washers (7), and two nuts (8) on hose collar assembly (5). Lockwire ring nut (4) to hose collar assembly mounting bolt (6). Use lockwire (E233).
5. Tighten the four clamps (2) along sta. 260.

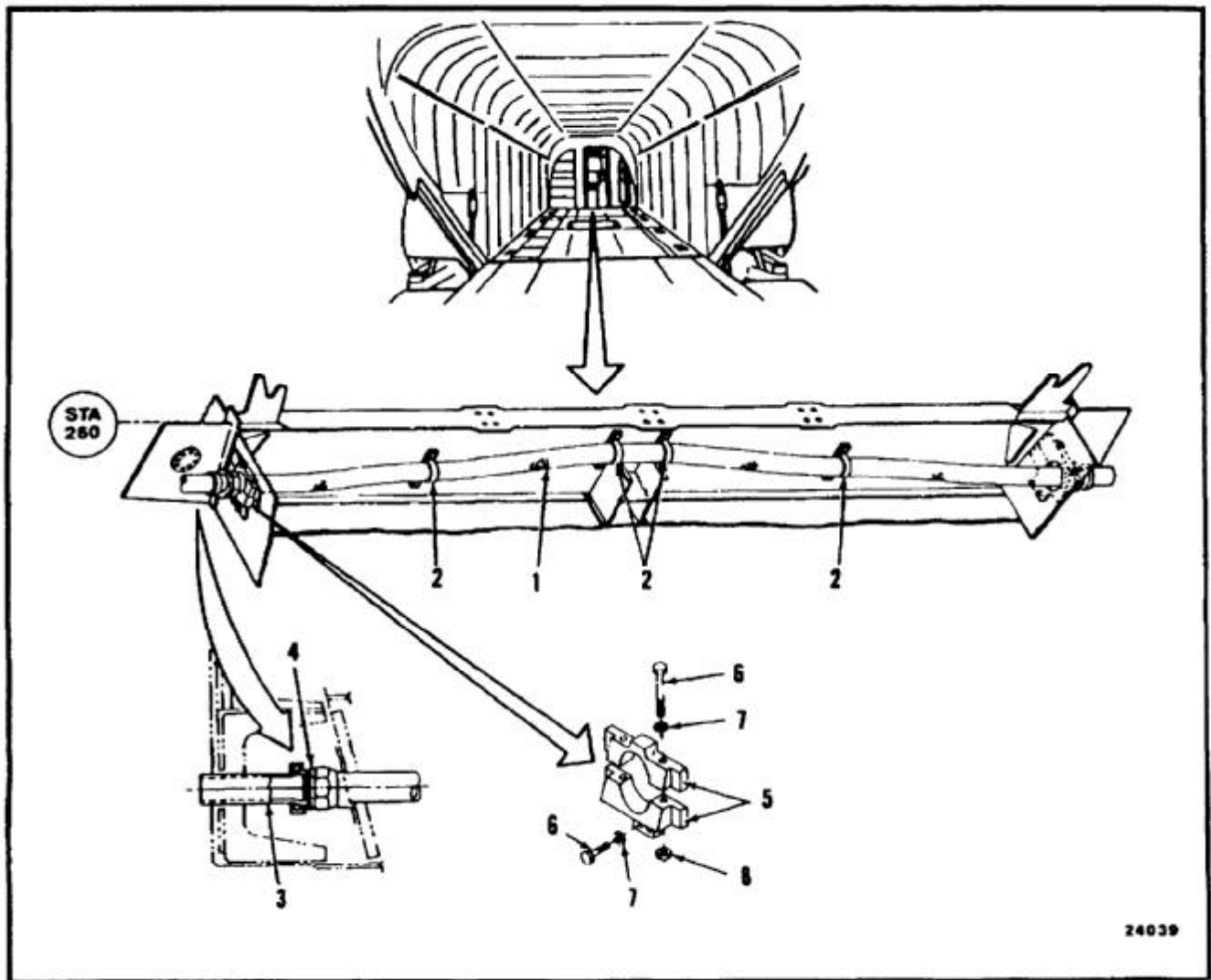

6. Working in the landing gear box, install access cover (8) with 26 bolts (9) and 26 sealing washers (10).
7. Install crossover hose elbow connection (11), preformed packing (12), and gasket (13).
8. Secure and tighten crossover hose elbow (11) to access cover (8) with six bolts (14) and six sealing washers (15).
9. Remove cap from hose assembly (16). Install hose assembly on crossover hose elbow (11).
10. Tighten nut (17) between elbow and hose assembly (16).
11. Remove barrier material and masking tape from tee (18). Clean any tape residue from tee with cleaning solvent (E162) and cloth (E135). Use goggles and wear gloves (E186).
12. Install elbow (19) between tee (18) and crossover hose elbow (11).
13. Hand-tighten ring nuts at either end of elbow. Lockwire ring nuts.

INSPECT**FOLLOW-ON MAINTENANCE:**

Install three floor panels (Task 2-207).
 Perform operational check of fuel system (TM 55-1520-240-T).
 Check for fuel leaks (Task 10-4).
 Forward right and left landing gear access door closed (Task 2-2).

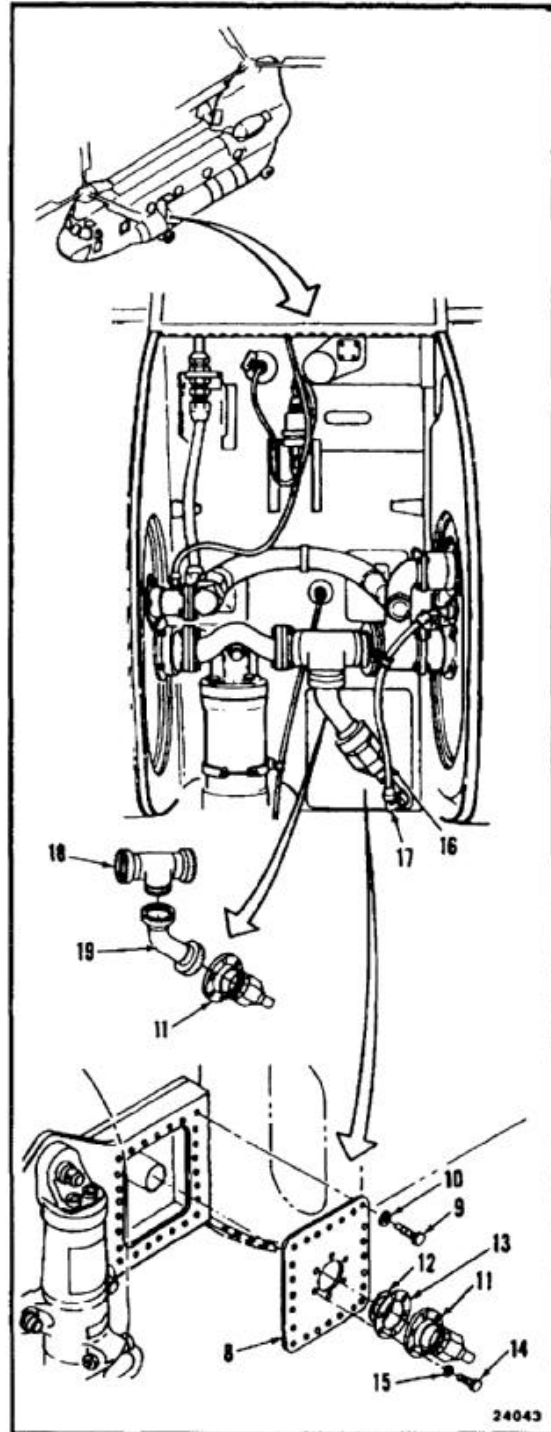

END OF TASK

INITIAL SETUP

General Safety Instructions:

Applicable Configurations:

With **82**

Tools:

Aircraft Mechanic's Tool Kit, NSN 5180-00-323-4692

Materials:

- Lockwire (E233)
- Dry Cleaning Solvent (E162)
- Gloves (E186)

Personnel Required:

- Medium Helicopter Repairer (2)
- Inspector

References:

TM 55-1520-240-23P

WARNING

All regulations and instructions for handling fuels shall be strictly observed.

WARNING

Dry cleaning solvent (E162) is flammable and toxic. It can irritate skin and cause burns. Use only in well-ventilated area, away from heat and open flame. In case of contact, immediately flush skin or eyes with water for at least **15 minutes**. Get medical attention for eyes.

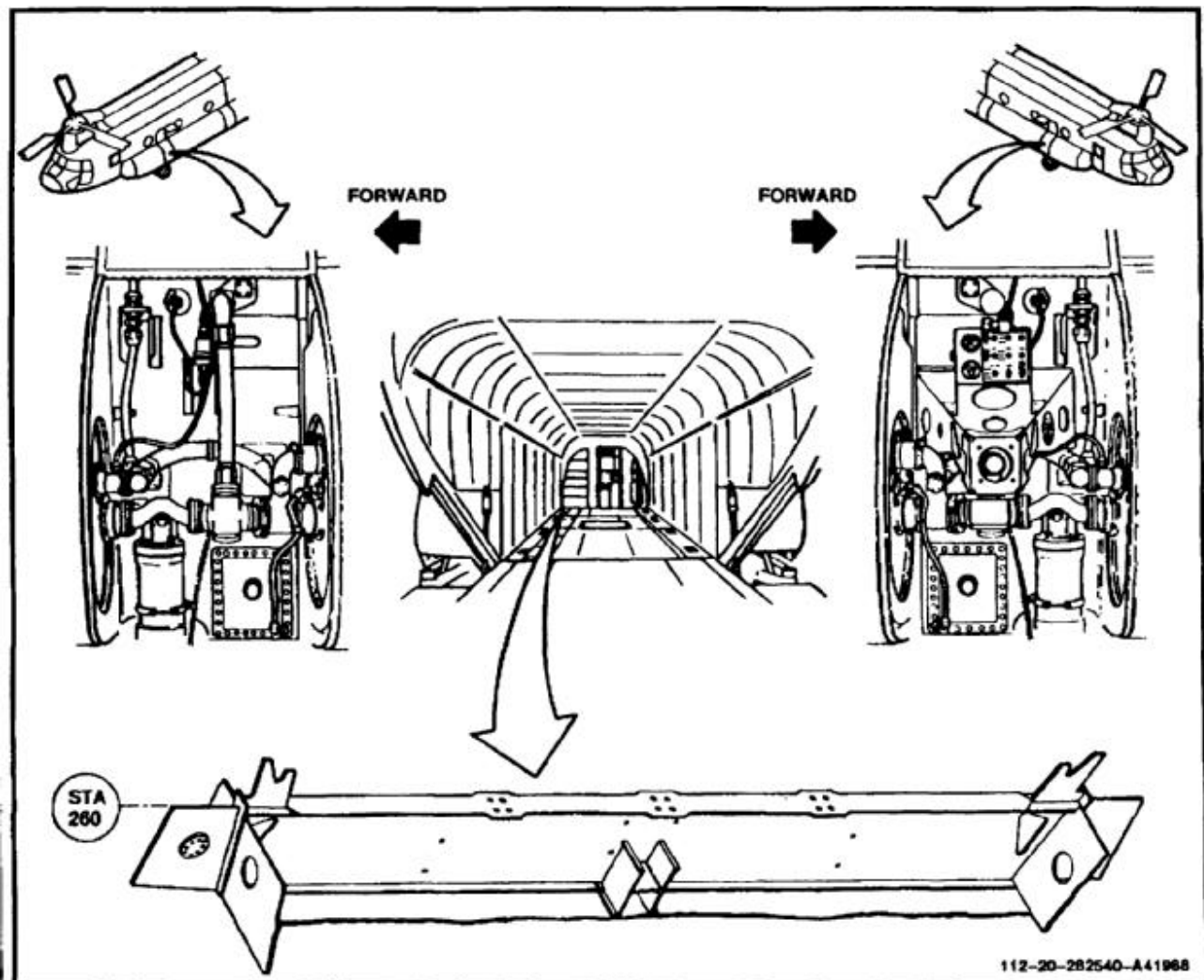

NOTE

The procedures for installing the crossover tube to the right and left crossover tube elbow connections are the same. The left side is described.

1. Working under the floor at sta. 260, install the crossover hose (1) loosely with four clamps (2) and associated hardware. Center the hose laterally.

2. Install crossover hose (1) on sleeve (3). Hand tighten ring nut (4).
3. Install hose collar assembly halves (5) on crossover hose (1).
4. Install and tighten three bolts (6), three washers (7), and two nuts (8) on hose collar assembly (5). Lockwire ring nut (4) to hose collar assembly mounting bolt (6). Use lockwire (E233).
5. Tighten the four clamps (2) along sta. 260.

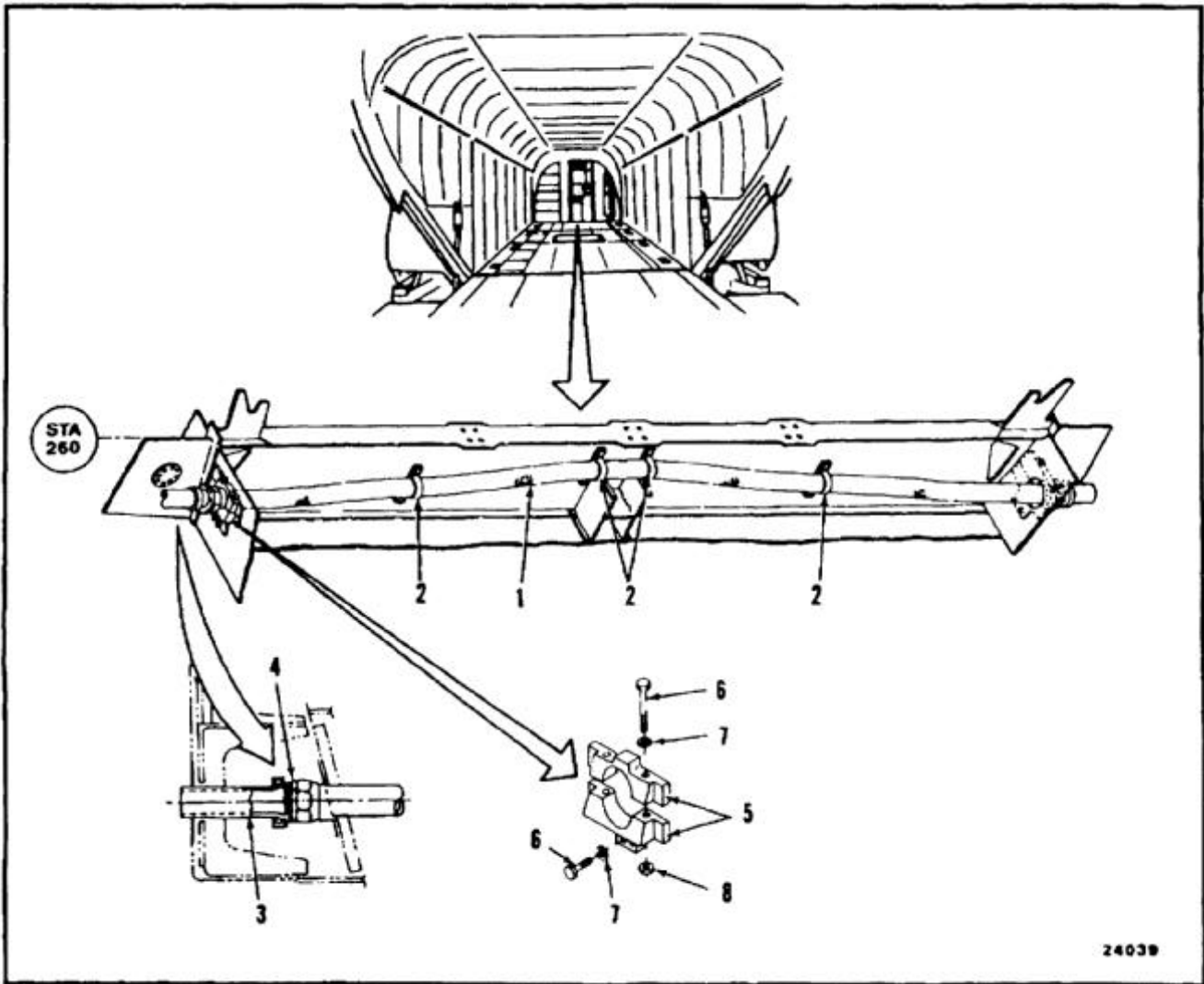

10-88.4 INSTALL CROSSOVER HOSE (Continued)

10-88.4

6. Working in the landing gear box, install access cover (8) with 26 bolts (9) and 26 sealing washers (10).
7. Install crossover hose elbow connection (11), preformed packing (12), and gasket (13).
8. Secure and tighten crossover hose elbow (11) to access cover (8) with six bolts (14) and six sealing washers (15).
9. Remove cap from hose assembly (16). Install hose assembly on crossover hose elbow (11).
10. Tighten nut (17) between elbow and hose assembly (16).
11. Remove barrier material and masking tape from tee (18). Clean any tape residue from tee with cleaning solvent (E162) and cloth (E135). Use goggles and wear gloves (E186).
12. Install elbow (19) between tee (18) and crossover hose elbow (11).
13. Hand-tighten ring nuts at either end of elbow. Lockwire ring nuts.

INSPECT**FOLLOW-ON MAINTENANCE:**

- Install three floor panels (Task 2-207).
- Perform operational check of fuel system (TM 55-1520-240-T).
- Check for fuel leaks (Task 10-4).
- Forward right and left landing gear access door closed (Task 2-2).

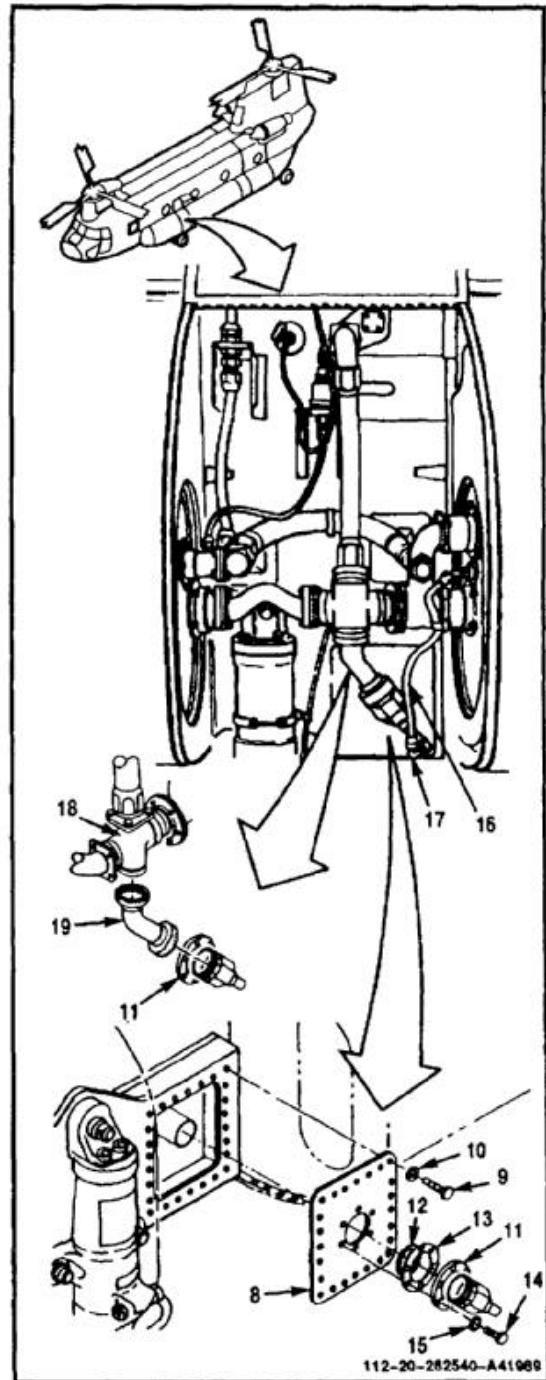

END OF TASK

INITIAL SETUP

Applicable Configurations:Without **82****Tools:**

Aircraft Mechanic's Tool Kit, NSN 5180-00-323-4692
 Grounded Container, 2 Quart or Equivalent

Materials:

Cloths (E135)
 Barrier Material (E80)
 Tape (E388)

Personnel Required:

Medium Helicopter Repairer

Equipment Condition:

Battery Disconnected (Task 1-39)
 Electrical Power Off
 Helicopter Grounded (Task 1-29)
 Forward Left Landing Gear Access Door Opened
 (Task 2-2)
 All Tanks on Left Side of Helicopter Defueled and Both
 Crossover Valves Closed (Task 10-34 or 10-35)

General Safety Instructions:

WARNING

All regulations and instructions
 for handling fuels shall be strictly
 observed.

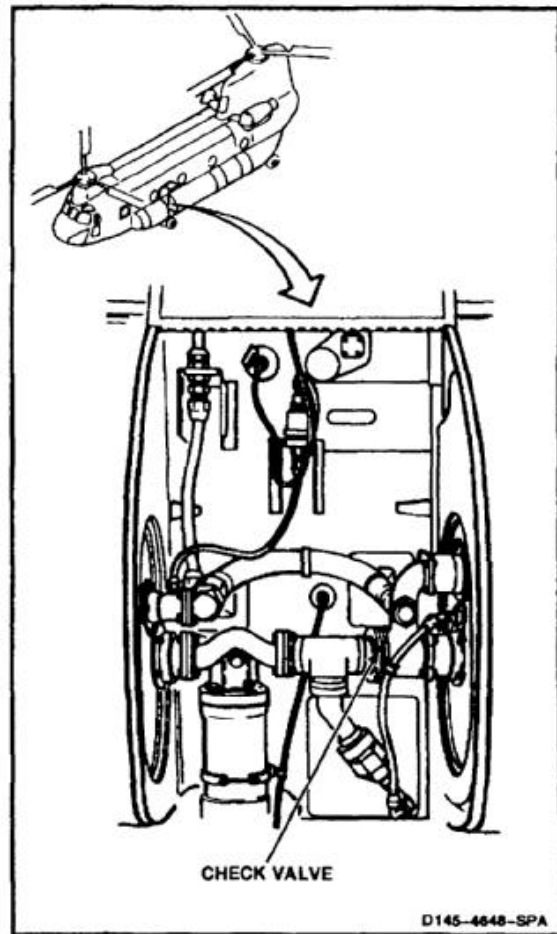

10-89 REMOVE NO. 1 SYSTEM (LEFT SIDE) MAIN FUEL TANK SERVICING CHECK VALVE (Continued)

10-89

1. Remove lockwire and loosen ring nut (1) on elbow (2) and three ring nuts (3) on tee (4).
2. Remove four bolts (5), washers (6) and nuts (7).
3. Remove tube (8), elbow (9) and tee (4). Use container for any spilled fuel.
4. Remove gasket (10).
5. Cover holes in elbow (2) and fitting (11). Use barrier material (E80) and tape (E388).

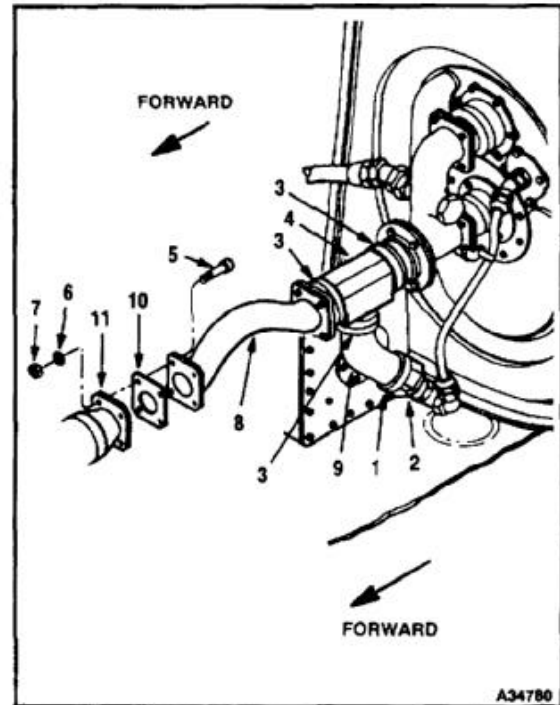

6. Remove four packings (12) from tube (8), elbow (9) and flanged connector (13).

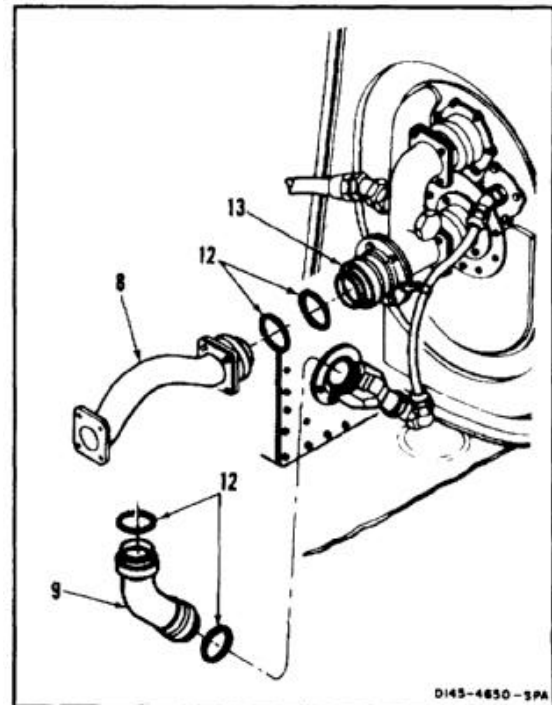

10-89 REMOVE NO. 1 SYSTEM (LEFT SIDE) MAIN FUEL TANK SERVICING CHECK VALVE (Continued)

10-89

7. Remove six screws (14).
8. Remove support plate (15), flanged connector (13) and check valve (16) from manifold (17).
9. Clean up any spilled fuel. Use cloths (E135).
10. Cover hole in manifold (17). Use barrier material (E80) and tape (E388).

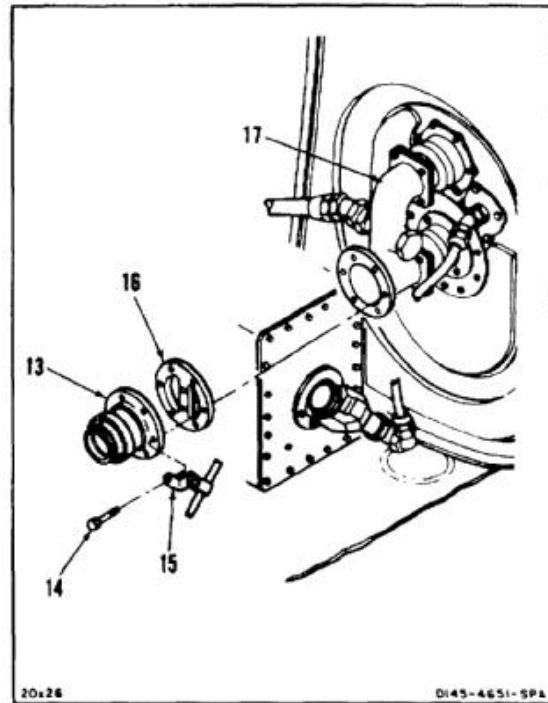
**FOLLOW-ON MAINTENANCE:**

None

END OF TASK

10-428

10-89.1 REMOVE NO. 1 SYSTEM (LEFT SIDE) MAIN FUEL TANK SERVICING CHECK VALVE

10-89.1

INITIAL SETUP**Applicable Configurations:**With **82****Tools:**

Aircraft Mechanic's Tool Kit, NSN 5180-00-323-4692
 Grounded Container, 2 Quart or Equivalent

Materials:

Cloths (E135)
 Barrier Material (E80)
 Tape (E388)

Personnel Required:

Medium Helicopter Repairer

Equipment Condition:

Battery Disconnected (Task 1-39)
 Electrical Power Off
 Helicopter Grounded (Task 1-29)
 Forward Left Landing Gear Access Door Opened
 (Task 2-2)
 All Tanks on Left Side of Helicopter Defueled and Both
 Crossover Valves Closed (Task 10-34 or 10-35)
 ERFS II Refueling Hose Removed (Task 10-55.2)

General Safety Instructions:**WARNING**

All regulations and instructions
 for handling fuels shall be strictly
 observed.

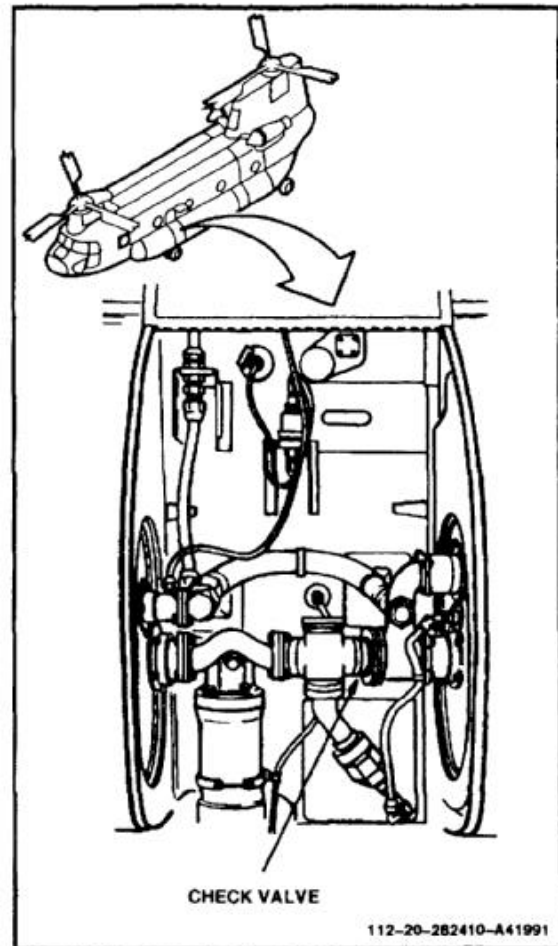

10-89.1 REMOVE NO. 1 SYSTEM (LEFT SIDE) MAIN FUEL TANK SERVICING CHECK VALVE (Continued)

1. Remove lockwire and loosen ring nut (1) on elbow (2) and three ring nuts (3) on tee (4).
2. Remove four bolts (5), washers (6), and nuts (7).
3. Remove tube (8), elbow (9), and tee (4). Use container for any spilled fuel.
4. Remove gasket (10).
5. Cover the holes in elbow (2) and fitting (11). Use barrier material (E80) and tape (E388).

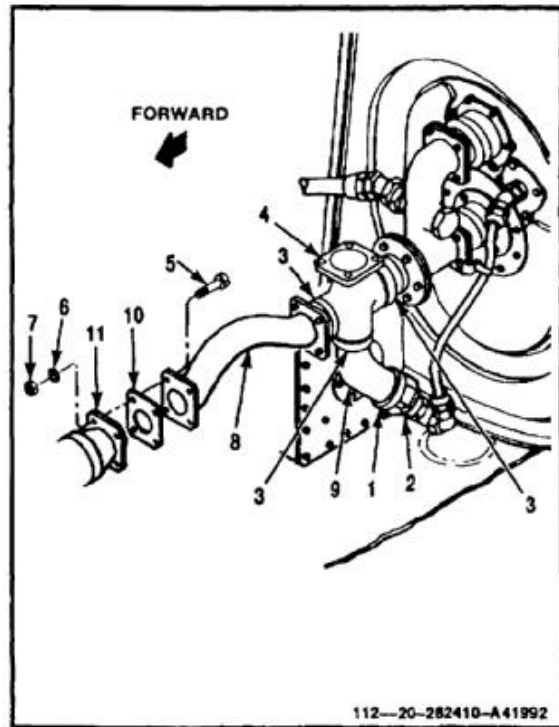

6. Remove four packings (12) from tube (8), elbow (9), and flanged connector (13).

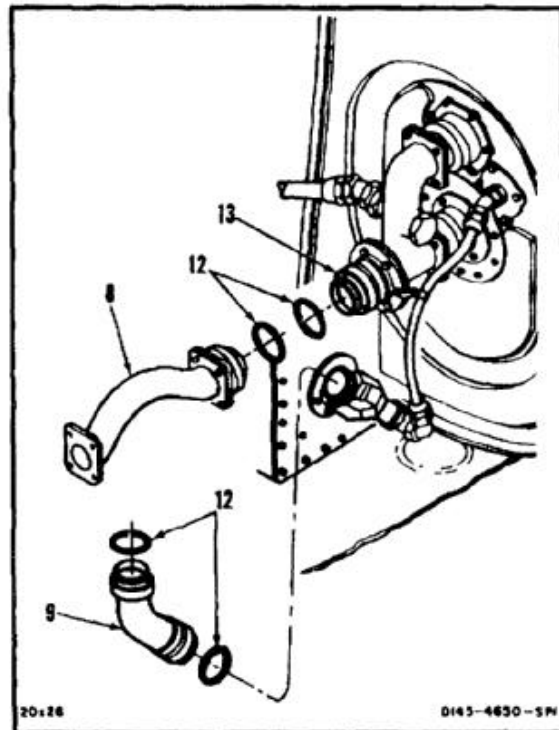

10-89.1 REMOVE NO. 1 SYSTEM (LEFT SIDE) MAIN FUEL TANK SERVICING CHECK VALVE (Continued)

10-89.1

7. Remove six screws (14).
8. Remove support plate (15), flanged connector (13), and check valve (16) from manifold (17).
9. Clean up any spilled fuel. Use cloths (E135).
10. Cover hole in manifold (17). Use barrier material (E80) and tape (E388).

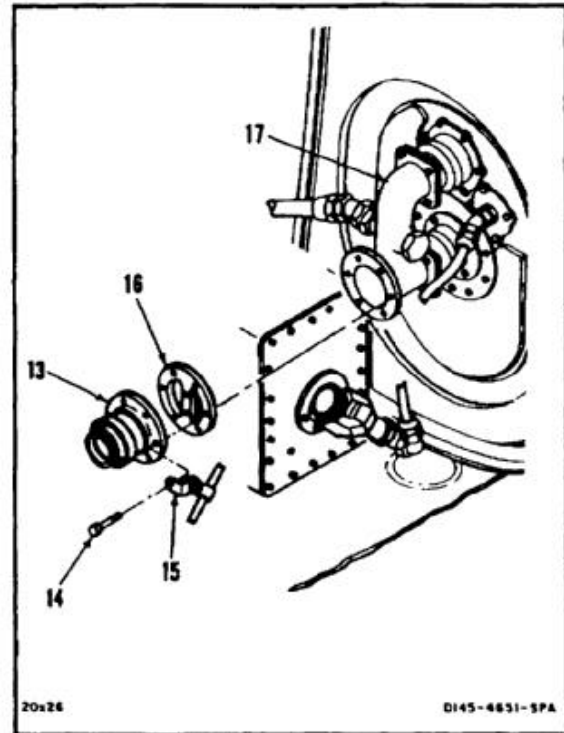
***FOLLOW-ON MAINTENANCE:***

None

END OF TASK

INITIAL SETUP

Applicable Configurations:Without **82****Tools:**

Aircraft Mechanic's Tool Kit, NSN 5180-00-323-4692

Materials:

Lockwire (E233)
 Dry Cleaning Solvent (E162)
 Gloves (E184.1)

Parts:

Packings
 Gaskets

Personnel Required:

Medium Helicopter Repairer
 Inspector

References:

TM 55-1520-240-23P

General Safety Instructions:**WARNING**

All regulations and instructions for handling fuels shall be strictly observed.

WARNING

Dry cleaning solvent (E162) is flammable and toxic. It can irritate skin and cause burns. Use only in well-ventilated area, away from heat and open flame. In case of contact, immediately flush skin or eyes with water for at least **15 minutes**. Get medical attention for eyes.

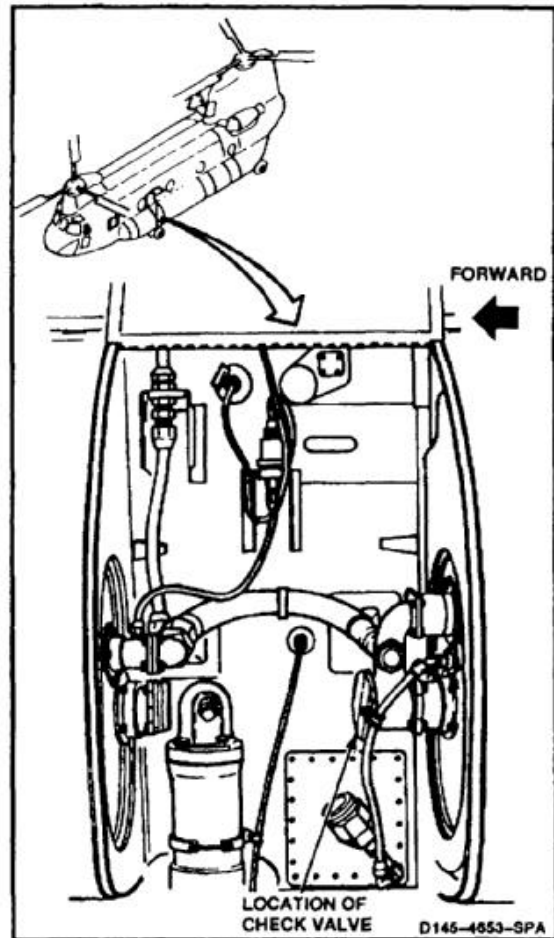

10-90 INSTALL NO. 1 SYSTEM (LEFT SIDE) MAIN FUEL TANK SERVICING CHECK VALVE (Continued)

10-90

1. Remove barrier material and masking tape from manifold (1). Clean any tape residue from face of flange. Use dry cleaning solvent (E162) and cloths (E135). Use goggles for eyes. Wear gloves (E184.1).
2. Position check valve (2), flanged connector (3) and support plate (4) on manifold (1).
3. Install six screws (5).

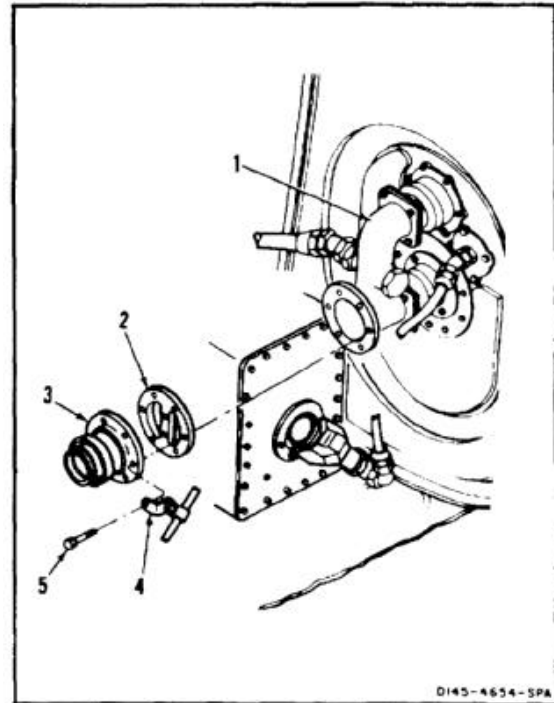

4. Install four packings (6), one on flanged connector (3), one on tube (7) and two on elbow (8).

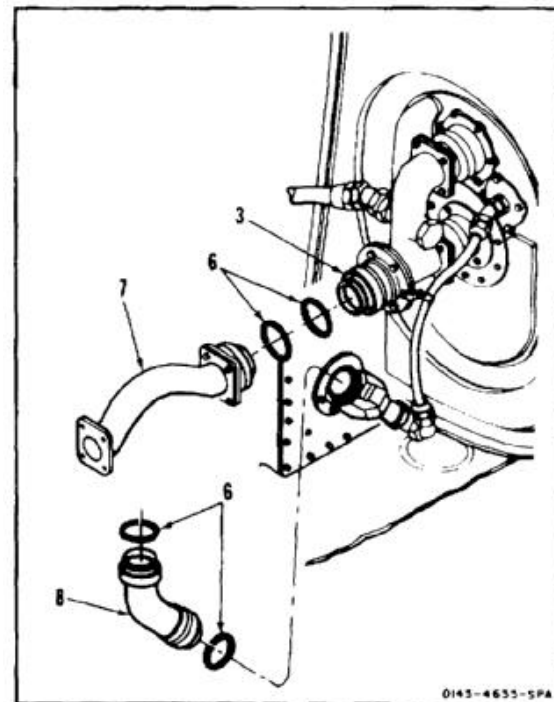

5. Remove barrier material and tape covering holes in fittings (9 and 10). Clean any residual tape adhesive. Use dry cleaning solvent (E162) and cloths (E135). Use goggles for eyes. Wear gloves (E184.1).
6. Position tube (7), elbow (8), and tee (11), between manifold (1), fitting (10), and breakaway fitting (9).
7. Position gasket (12) between tube (7) and fitting (9).
8. Install four bolts (13), washers (14), and nuts (15).
9. Tighten three rings nuts (16) on tee (11). Tighten ring nut (17) on elbow (8). Lockwire ring nuts. Use lockwire (E233).

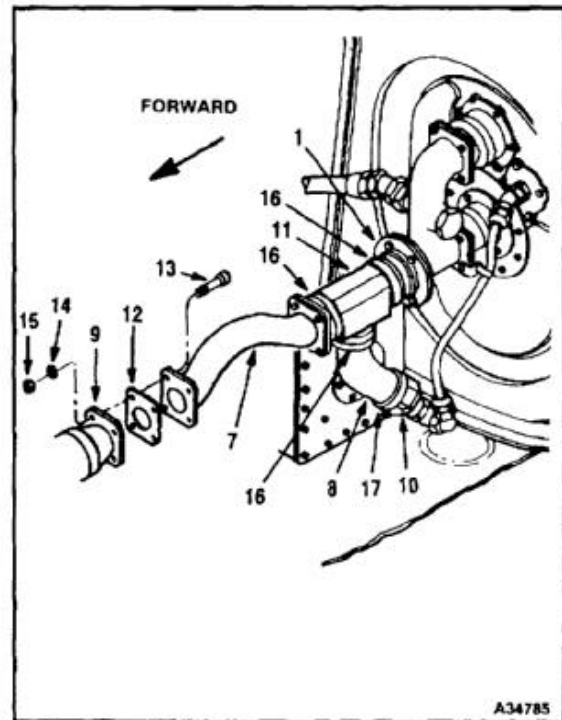
**INSPECT****FOLLOW-ON MAINTENANCE:**

- Refuel helicopter (Task 1-51).
- Bleed fuel system (Task 10-121).
- Perform operational check of fuel system (TM 55-2840-240-T).
- Check for leaks (Task 10-4).
- Close forward left landing gear access panel (Task 2-2).

END OF TASK

INITIAL SETUP**Applicable Configurations:**With **82****Tools:**

Aircraft Mechanic's Tool Kit, NSN 51 80-00-323-4692

Materials:

Lockwire (E233)
 Dry Cleaning Solvent (E162)
 Gloves (E184.1)

Parts:

Packings
 Gaskets

Personnel Required:

Medium Helicopter Repairer
 Inspector

References:

TM 55-1520-240-23P

General Safety Instructions:**WARNING**

All regulations and instructions for handling fuels shall be strictly observed.

WARNING

Dry cleaning solvent (E162) is flammable and toxic. It can irritate skin and cause burns. Use only in well-ventilated area, away from heat and open flame. In case of contact, immediately flush skin or eyes with water for at least **15 minutes**. Get medical attention for eyes.

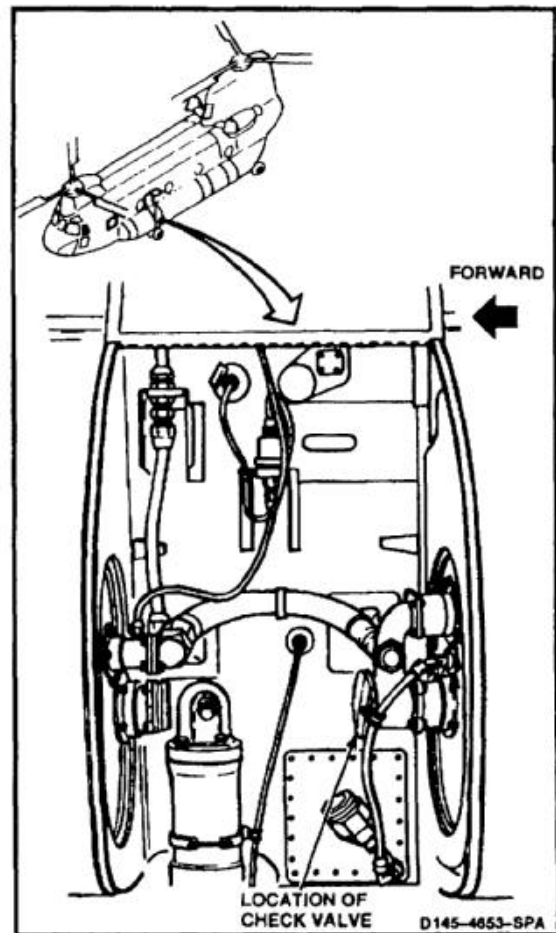

10-90.1 INSTALL NO. 1 SYSTEM (LEFT SIDE) MAIN FUEL TANK SERVICING CHECK VALVE (Continued)

1. Remove barrier material and masking tape from manifold (1). Clean any tape residue from face of flange. Use dry cleaning solvent (E162) and cloths (E135). Use goggles for eyes. Wear gloves (E184.1).
2. Position check valve (2), flanged connector (3), and support plate (4) on manifold (1).
3. Install six screws (5).

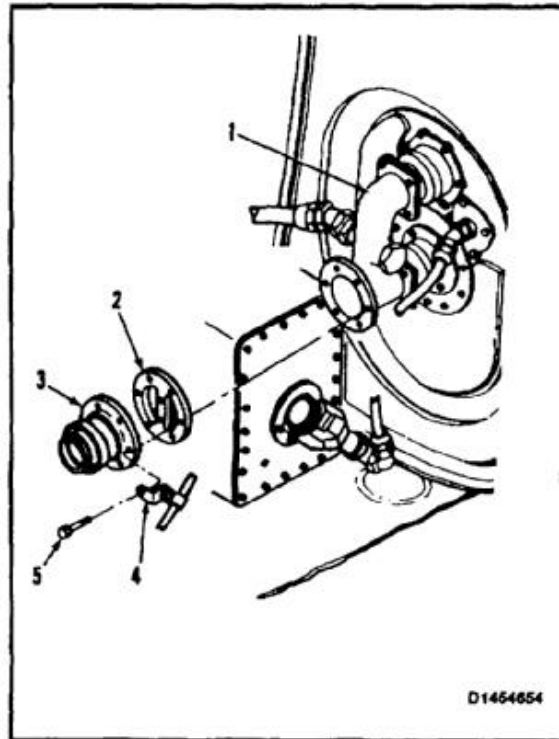

4. Install four packings (6), one on flanged connector (3), one on tube (7) and two on elbow (8).

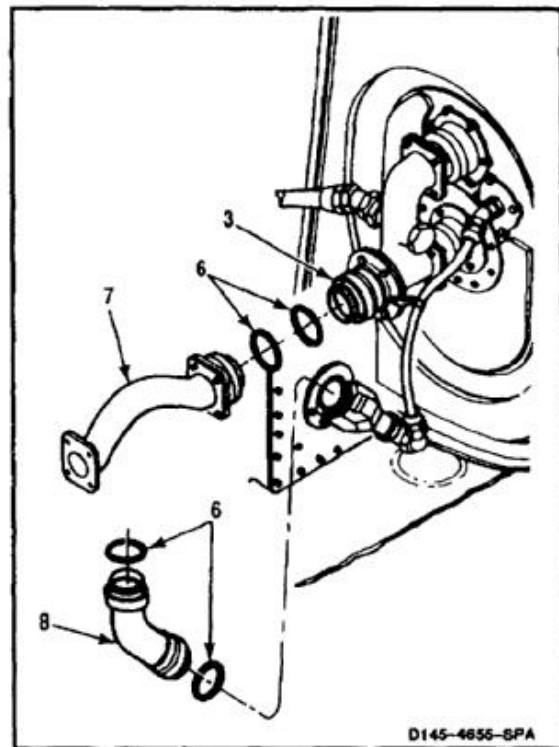

10-90.1 INSTALL NO. 1 SYSTEM (LEFT SIDE) MAIN FUEL TANK SERVICING CHECK VALVE (Continued)

10-90.1

5. Remove barrier material and tape covering holes in fittings (9 and 10). Clean any residual tape adhesive. Use dry cleaning solvent (E162) and cloths (E135). Use goggles for eyes. Wear gloves (E184.1).
6. Position tube (7), elbow (8), and fitting (11) between manifold (1), fitting (10), and breakaway fitting (9).
7. Position gasket (12) between tube (7) and fitting (9).
8. Install four bolts (13), washers (14), and nuts (15).
9. Tighten three ring nuts (16) on fitting (11). Tighten ring nut (17) on elbow (8). Lockwire ring nuts. Use lockwire (E233).

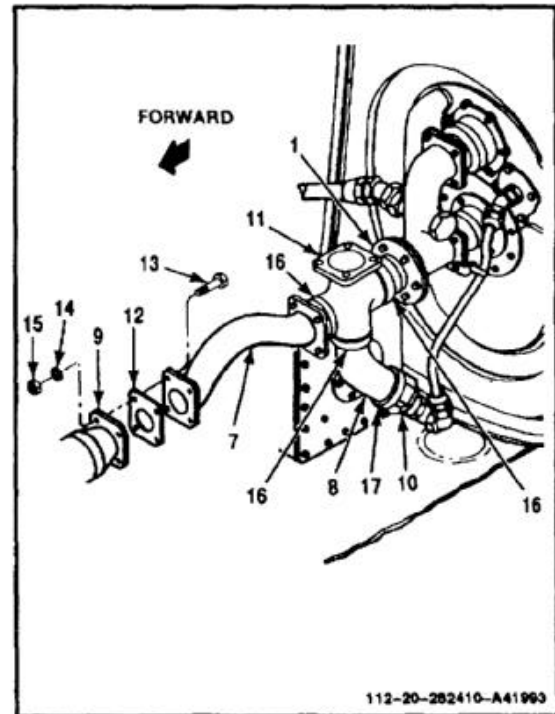
INSPECT**FOLLOW-ON MAINTENANCE:**

- Install ERFS II refueling hose (Task 10-55.3).
- Refuel helicopter (Task 1-51).
- Bleed fuel system (Task 10-121).
- Perform operational check of fuel system (TM 55-1520-240-T).
- Check for leaks (Task 10-4).
- Close forward left landing gear access panel (Task 2-2).

END OF TASK

INITIAL SETUP

Applicable Configurations:

All

Tools:

Aircraft Mechanic's Tool Kit, NSN 5180-00-323-4692
 Strap Wrench
 Grounded Container, 2 Quart or Equivalent

Materials:

Cloths (E135)
 Barrier Material (E80)
 Tape (E388)

Personnel Required:

Medium Helicopter Repairer

Equipment Condition:

Battery Disconnected (Task 1-39)
 Electrical Power Off
 Helicopter Grounded (Task 1-29)
 Forward Right Landing Gear Access Door Opened
 (Task 2-2)
 All Tanks on Right Side of Helicopter Defueled and
 Both Crossover Valves Closed (Task 10-34 or
 10-35)
 Remove Refueling Adapter (Task 10-87)

General Safety Instructions:**WARNING**

All regulations and instructions
 for handling fuels shall be strictly
 observed.

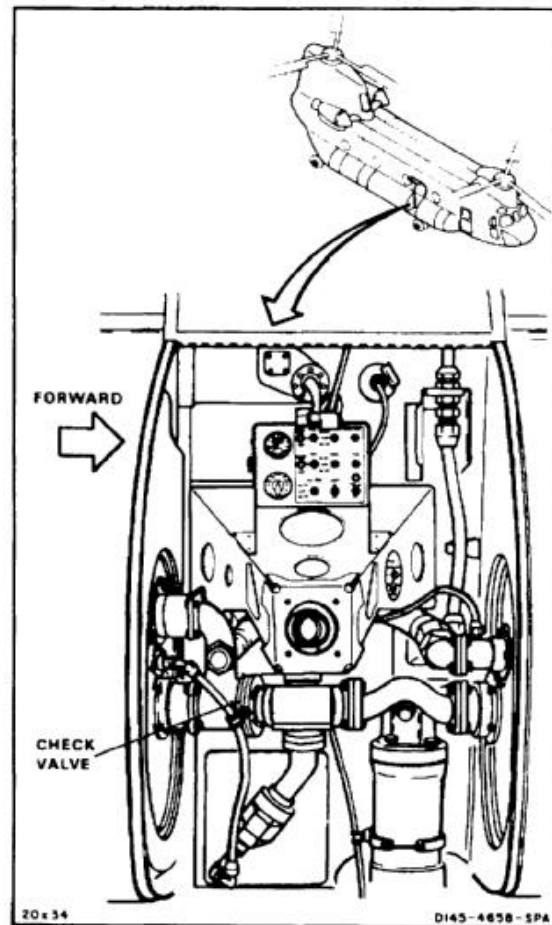

10-91 REMOVE NO. 2 SYSTEM (RIGHT SIDE) MAIN FUEL TANK SERVICING CHECK VALVE (Continued)

10-91

1. Remove lockwire and loosen ring nut (1) on cross (2).
2. Remove elbow (3).
3. Remove four bolts (4), washers (5), and nuts (6).
4. Loosen three ring nuts (7) on cross (2) and ring nut (8) on elbow (9).
5. Remove cross (2), tube assembly (10) and elbow (11). Use container for any spilled fuel.
6. Remove gasket (12).
7. Cover holes in elbow (9) and fitting (13). Use barrier material (E80) and tape (E388).

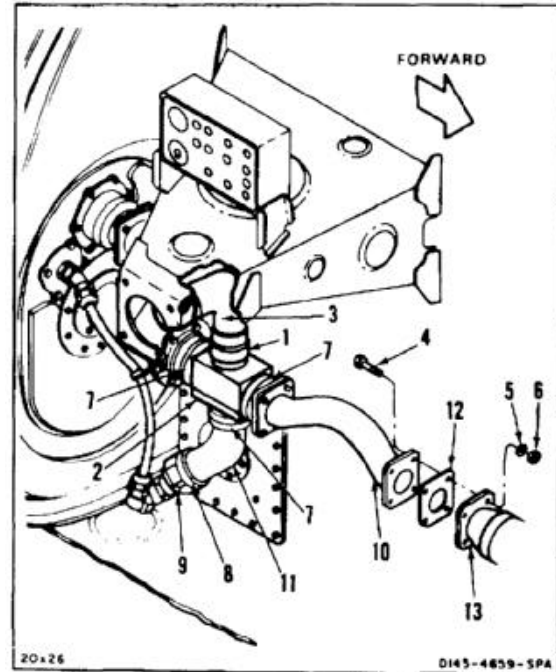

8. Remove six packings (14) from elbow (3), tube (10), elbow (11), and flanged connector (15).

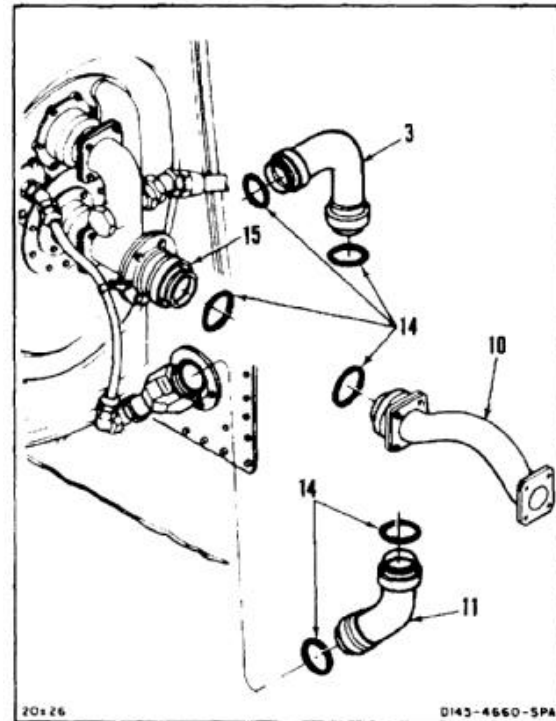

10-91 REMOVE NO. 2 SYSTEM (RIGHT SIDE) MAIN FUEL TANK SERVICING CHECK VALVE (Continued)

10-91

9. Remove six screws (16).
10. Remove support plate (17), flanged connector (15) and check valve (18) from manifold (19).
11. Clean up any spilled fuel. Use cloths (E135).
12. Cover hole in manifold (19). Use barrier material (E80) and tape (E388).

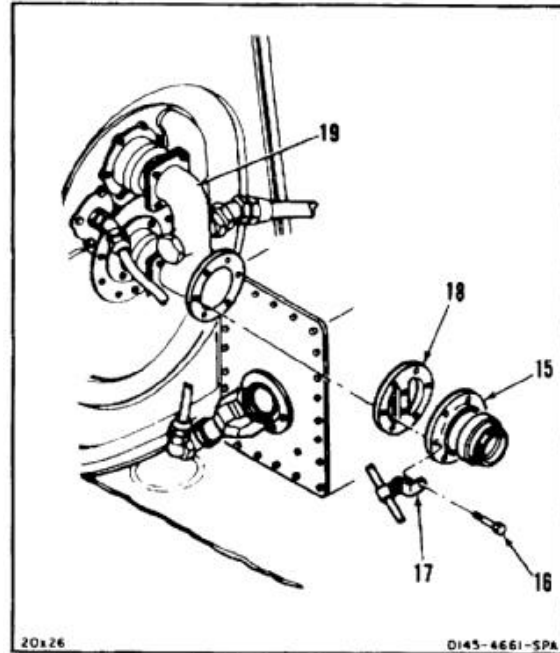
**FOLLOW-ON MAINTENANCE:**

None

END OF TASK

10-440

INITIAL SETUP

Applicable Configurations:

All

Tools:

Aircraft Mechanic's Tool Kit, NSN 5180-00-323-4692
Strap Wrench

Materials:

Lockwire (E233)
Dry Cleaning Solvent (E162)
Gloves (E186)
Cloths (E135)

Parts:

Packings
Gaskets

Personnel Required:

Medium Helicopter
Inspector

References:

TM 55-1520-240-23P

General Safety Instructions:**WARNING**

All regulations and instructions for handling fuels shall be strictly observed.

WARNING

Dry cleaning solvent (E162) is flammable and toxic. It can irritate skin and cause burns. Use only in well-ventilated area, away from heat and open flame. In case of contact, immediately flush skin or eyes with water for at least **15 minutes**. Get medical attention for eyes.

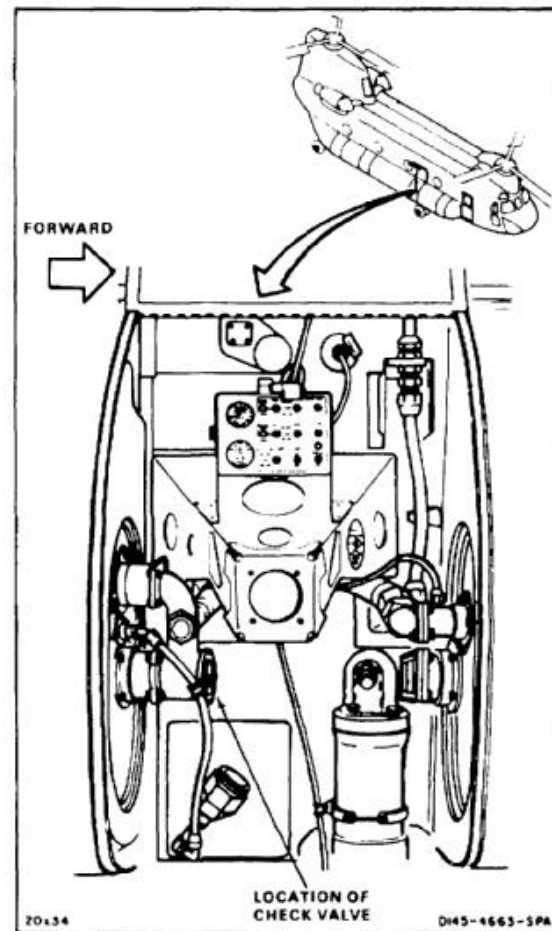

10-92 INSTALL NO. 2 SYSTEM (RIGHT SIDE) MAIN FUEL TANK SERVICING CHECK VALVE (Continued)

1. Remove barrier material and tape from manifold (1). Clean any tape residue from face of flange. Use dry cleaning solvent (E162) and cloths (E135). Use goggles for eyes. Wear gloves (E186).
2. Position check valve (2), flanged connector (3) and support plate (4) on manifold (1).
3. Install six screws (5).

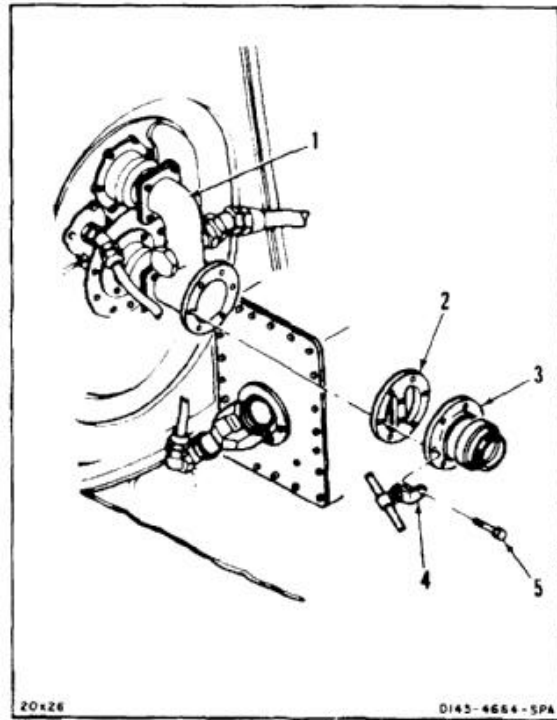

4. Install six packings (6), two on elbow (7), two on elbow (8), one on tube (9) and one on flanged connector (3).

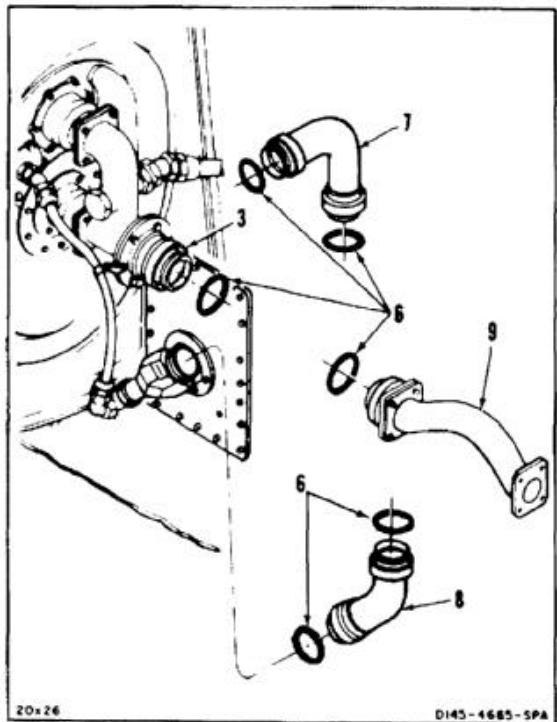

10-92 INSTALL NO. 2 SYSTEM (RIGHT SIDE) MAIN FUEL TANK SERVICING CHECK VALVE (Continued)

10-92

5. Remove barrier material and tape from two fittings (10 and 11). Clean any tape residue. Use dry cleaning solvent (E162) and cloths (E135). Use goggles for eyes. Wear gloves (E186).

CAUTION

Do not damage packings during assembly.

6. Position elbow (8), cross (12), and tube (9) between manifold (1) and two fittings (10 and 11).
7. Position gasket (13).
8. Tighten three ring nuts (14) on cross (12). Tighten ring nut (15) on fitting (10).
9. Install four bolts (16), washers (17), and nuts (18).

CAUTION

Elbow must be positioned with flow direction arrow inboard and down. Structural damage can occur if elbow installation is incorrect.

10. Position elbow (19) with flow direction arrow pointed inboard and down into cross (12). Tighten ring nut (20).
11. Lockwire four ring nuts (14 and 15). Use lockwire (E233).

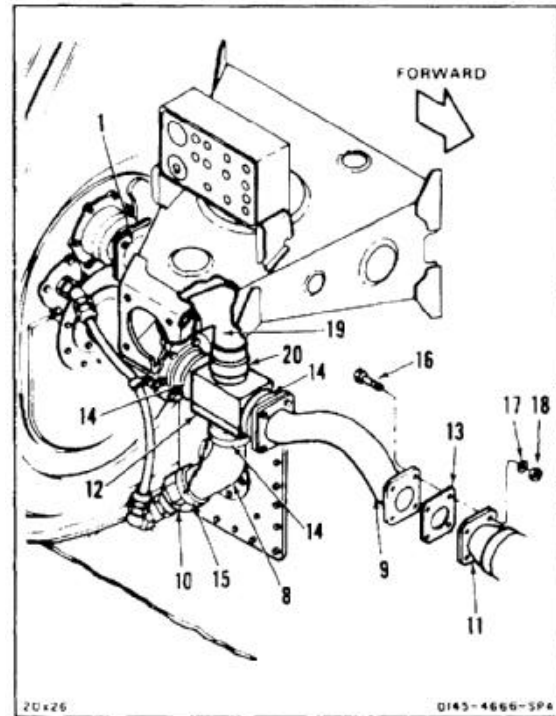
**INSPECT****FOLLOW-ON MAINTENANCE:**

- Install refueling adapter (Task 10-88).
- Refuel helicopter (Task 1-51).
- Bleed fuel system (Task 10-121).
- Perform operational check of fuel system (TM 55-1520-240-T).
- Check for leaks (Task 10-4).
- Close forward right landing gear access panel (Task 2-2).

END OF TASK

INITIAL SETUP

Applicable Configurations:

All

Tools:

Aircraft Mechanic's Tool Kit, NSN 5180-00-323-4692
 Grounded Container, 2 Quart or Equivalent

Materials:

Cloths (E135)

Personnel Required:

Medium Helicopter Repairer

Equipment Condition:

- Battery Disconnected (Task 1-39)
- Electrical Power Off
- Helicopter Grounded (Task 1-29)
- Aft Intertank Access Door Opened (Task 2-185)
- All Tanks on Affected Side of Aircraft Defueled and Both Crossover Valves Closed (Task 10-34 or 10-35)

General Safety Instructions:

WARNING

All regulations and instructions for handling fuels shall be strictly observed.

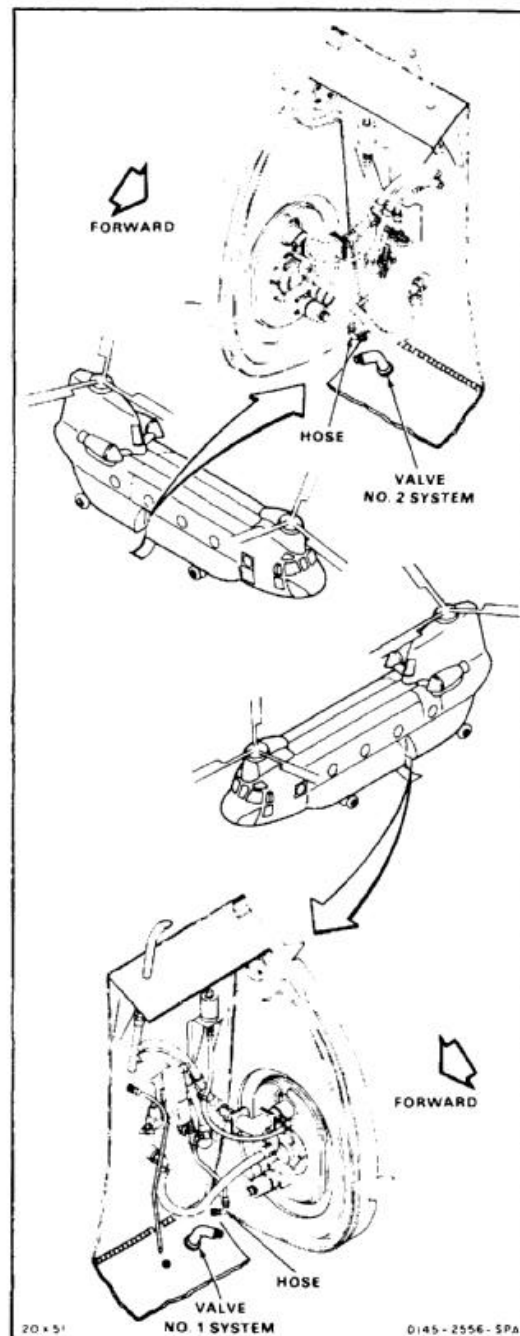

NOTE

Procedure is same to remove No. 1 or No. 2 system drain valve. No. 2 drain valve is shown here.

1. Turn poppet cock (1) **1/4 turn** clockwise, push up, and hold. Allow fuel to drain. Use container for fuel.
2. Release poppet cock (1).
3. Disconnect hose (2) from nipple (3). Plug hose.
4. Remove four bolts (4), washers (5), and nuts (6). Remove drain valve (7).
5. Remove union (3) and packing (8) from valve (7). Plug valve.
6. Clean up any spilled fuel. Use cloths (E135).

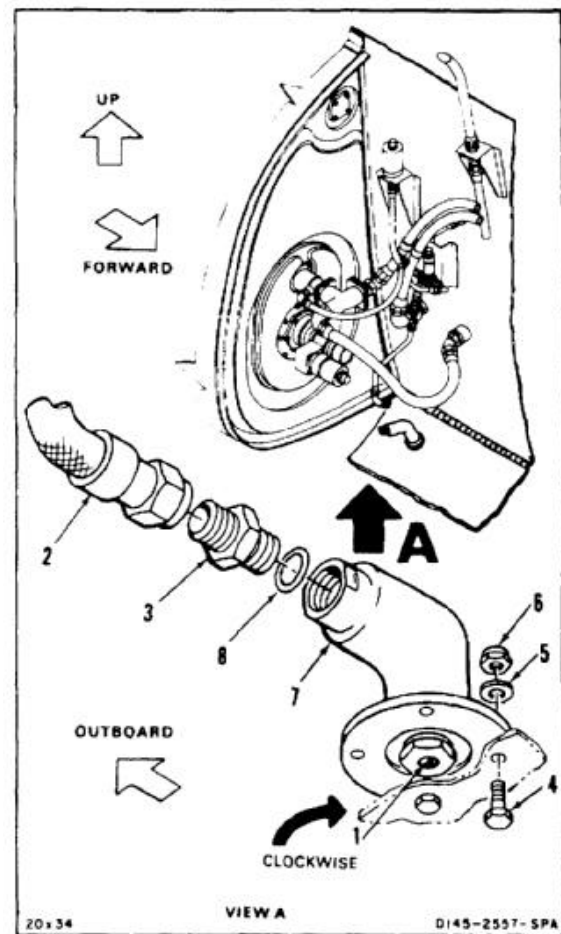
**FOLLOW-ON MAINTENANCE:**

None

END OF TASK

INITIAL SETUP

Applicable Configurations:

All

Tools:

Aircraft Mechanic's Tool Kit, NSN 5180-00-323-4692
 Grounded Container, 2 Quart or Equivalent

Materials:

Cloths (E135)

Parts:

Packing

Personnel Required:

Medium Helicopter Repairer

Equipment Condition:

Battery Disconnected (Task 1-39)
 Electrical Power Off
 Helicopter Grounded (Task 1-29)
 Aft Intertank Access Door Opened (Task 2-185)
 All Tanks on Affected Side of Aircraft Defueled and
 Both Crossover Valves Closed (Task 10-34 or
 10-35)

General Safety Instructions:**WARNING**

All regulations and instructions
 for handling fuels shall be strictly
 observed.

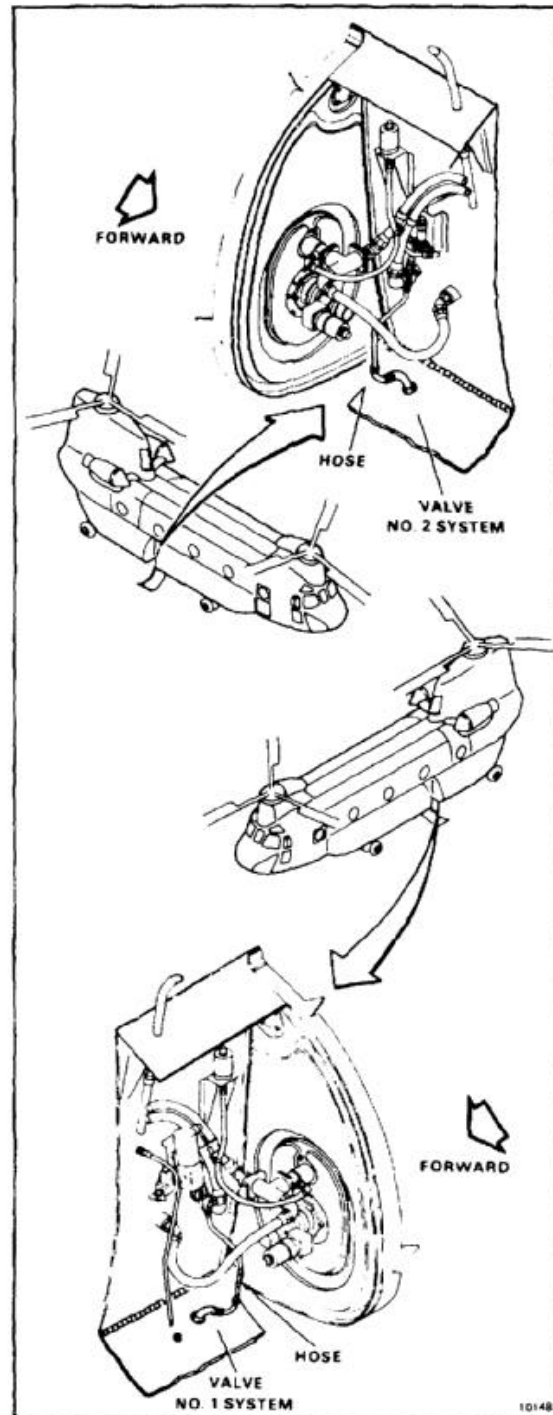

NOTE

Procedure is same to repair No. 1 or No. 2 system drain valve. No. 2 drain valve is shown here.

1. Unscrew and remove poppet body (1) from valve housing (2).

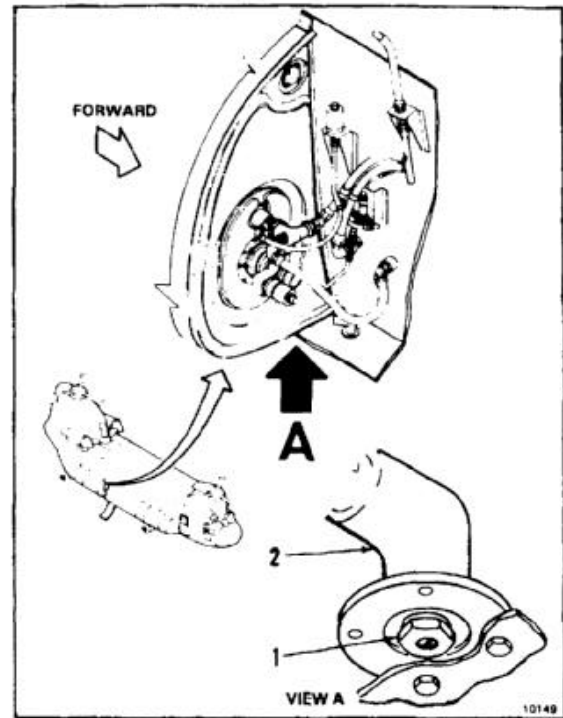

2. Remove packing (3) from poppet body (1).
3. Install new packing (3) on poppet body (1).

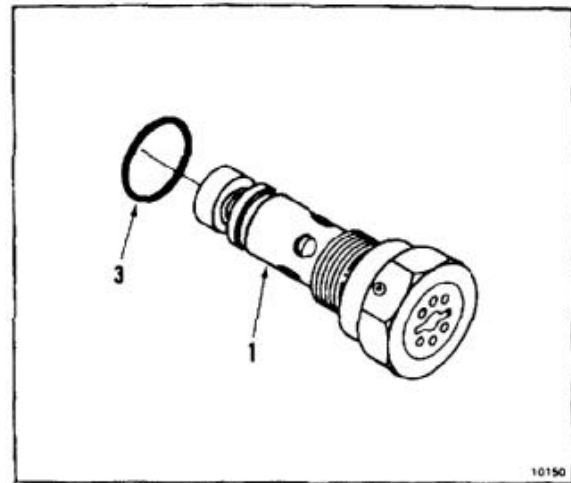

4. Install poppet body (1) in valve housing (2).

INSPECT

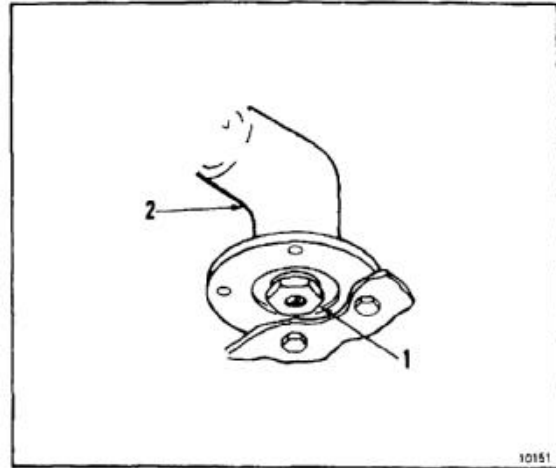

FOLLOW-ON MAINTENANCE:

- Refuel aircraft (Task 1-51).
- Bleed fuel system (Task 10-121).
- Perform test of fuel feed system (Task 10-120).
- Check for leaks (Task 10-4).
- Close aft intertank access door (2-188).

END OF TASK

10-448

INITIAL SETUP

Applicable Configurations:

All

Tools:

Aircraft Mechanic's Tool Kit, NSN 51 80-00-323-4692

Materials:

None

Parts:

Packing

Personnel Required:

Medium Helicopter Repairer
Inspector

References:

TM 55-1520-240-23P

General Safety Instructions:

WARNING

All regulations and instructions for handling fuels shall be strictly observed.

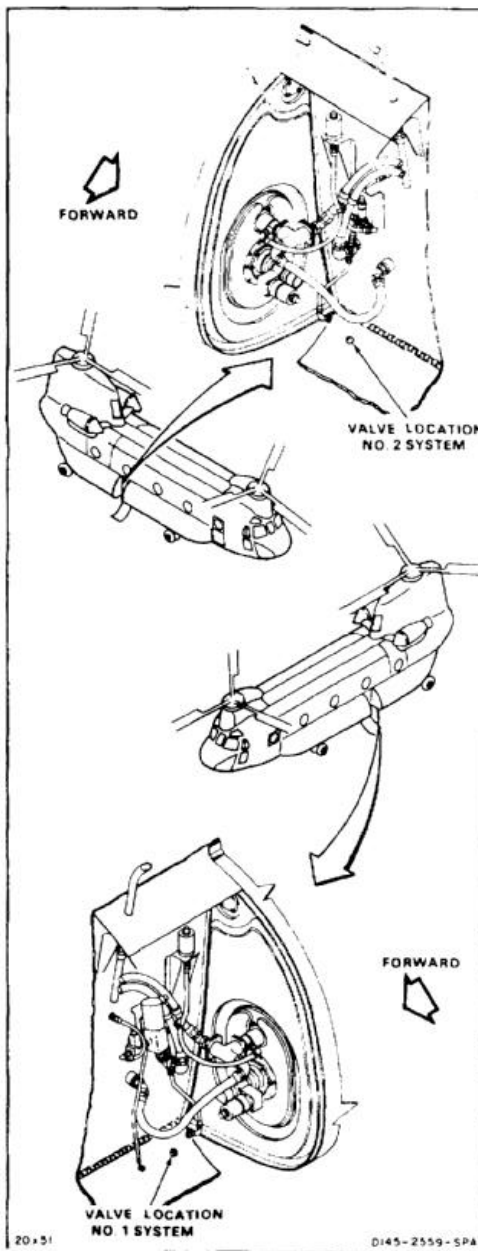

NOTE

Procedure is same to install No. 1 or No. 2 system drain valve. No. 2 drain valve is shown here.

1. Remove plug from drain valve (1).
2. Install nipple (2) and packing (3) in drain valve (1).
3. Position drain valve (1) on pod (4). Make sure valve (1) points outboard.
4. Install four bolts (5), washers (6), and nuts (7).
5. Remove plug from hose (8).
6. Connect hose (8) to nipple (2).

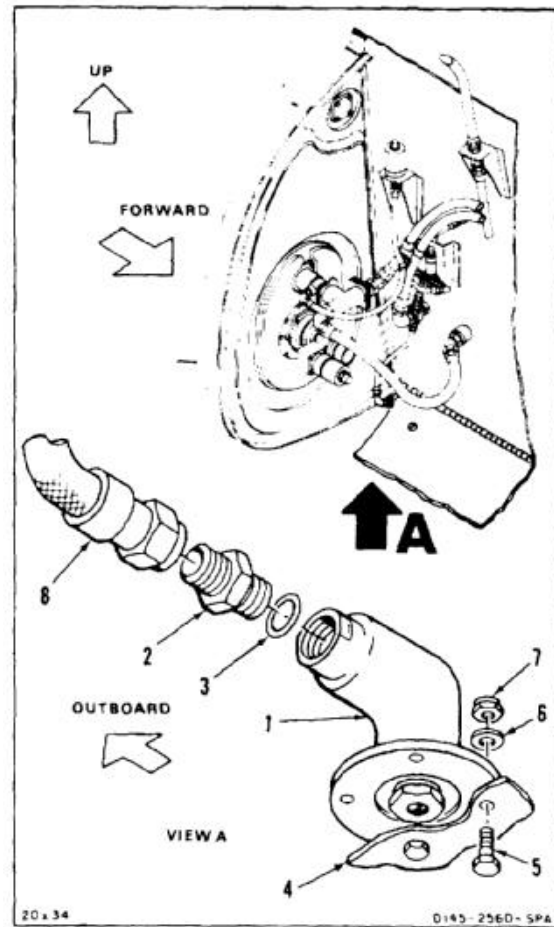
INSPECT**FOLLOW-ON MAINTENANCE:**

- Refuel aircraft (Task 1-51).
- Bleed fuel system (Task 10-121).
- Perform test of fuel feed system (Task 10-120).
- Check for leaks (Task 10-4).
- Close aft intertank access door (Task 2-188).

END OF TASK

10-450

INITIAL SETUP

Applicable Configurations:

All

Tools:

Aircraft Mechanic's Tool Kit, NSN 5180-00-323-4692
 Wrench, Open End, 1-1/2 Inch
 Grounded Container, 2 Quart or Equivalent

Materials:

Cloths (E135)

Personnel Required:

Medium Helicopter Repairer

Equipment Condition:

Battery Disconnected (Task 1-39)
 Electrical Power Off
 Helicopter Grounded (Task 1-29)
 Aft Intertank Access Door Opened (Task 2-185)
 All Tanks on Affected Side of Helicopter Defueled
 and Both Crossover Valves Closed (Task 10-34
 or 10-35)
 Shut Off Valve Removed (Task 10-81)

General Safety Instructions:**WARNING**

All regulations and instructions
 for handling fuels shall be strictly
 observed.

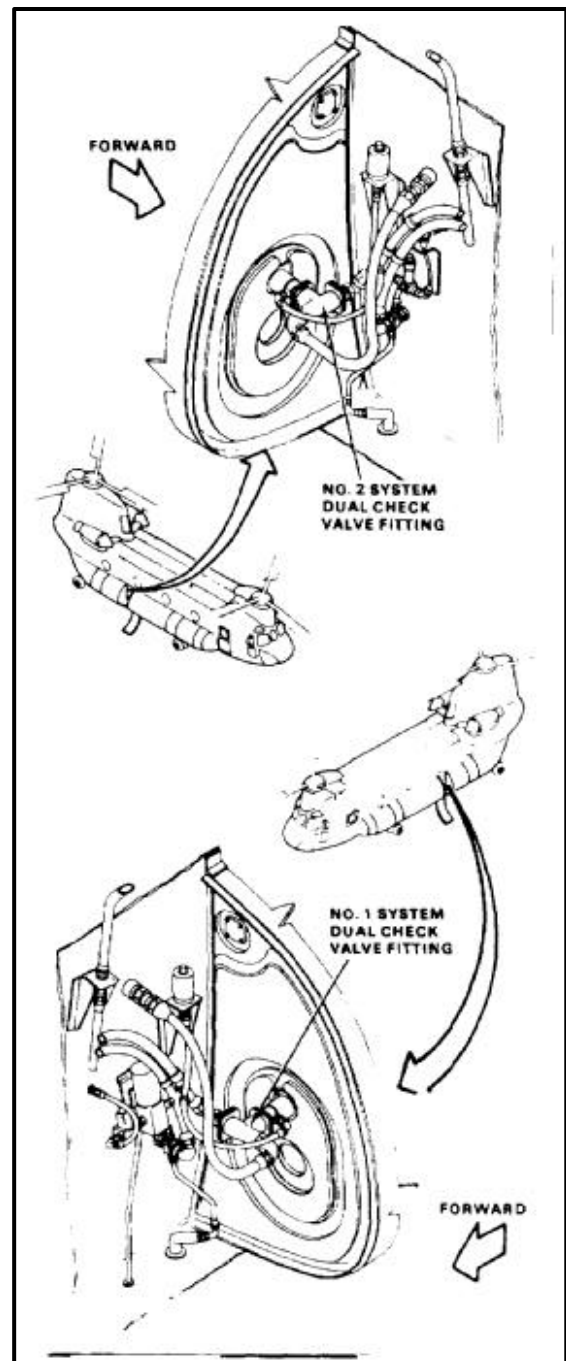

CAUTION

Do not allow dual check valve breakaway fitting (1) to turn within its mounting when disconnecting fuel and pressure lines. Otherwise, valve can fall and cause fuel blockage.

NOTE

Procedure is same to remove No. 1 or No. 2 system dual check valve fittings. No. 2 system fitting is shown here.

1. Hold dual check valve breakaway fitting (1) with a strap wrench and disconnect hose (2) (inside aft fuel tank). Remove conical seal (3) from hose fitting. Catch spilled fluid. Use a grounded container.
2. Hold dual check valve breakaway fitting (1) with a strap wrench and disconnect hoses (4 and 5). Remove conical seals (6 and 7). Catch spilled fuel. Use a grounded container.
3. Hold dual check valve breakaway fitting (1) with a strap wrench and disconnect pressure hose (8).
4. Cap fitting (1) and plug hoses (2, 4, 5, and 8).
5. Remove four screws (10) and washers (11) from flange (12) of dual check valve breakaway fitting (1) and remove fitting from tank access door (13).

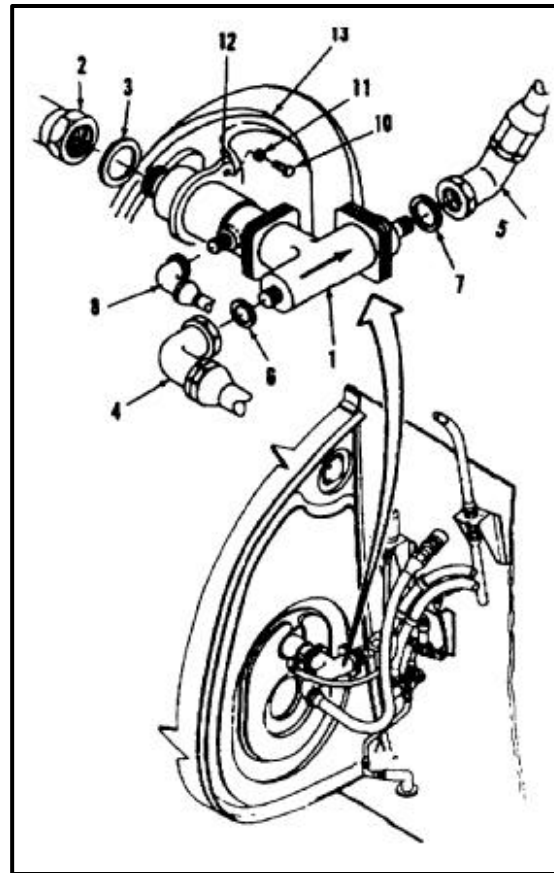

FOLLOW-ON MAINTENANCE:

None

END OF TASK

10-452

INITIAL SETUP

Applicable Configurations:

All

Tools:

Aircraft Mechanic's Tool Kit, NSN 51 80-00-323-4692

Materials

None

Parts:

Packings

Personnel Required:Medium Helicopter Repairer
Inspector**References:**

TM 55-1520-240-23P

General Safety Instructions:**WARNING**

All regulations and instructions for handling fuels shall be strictly observed.

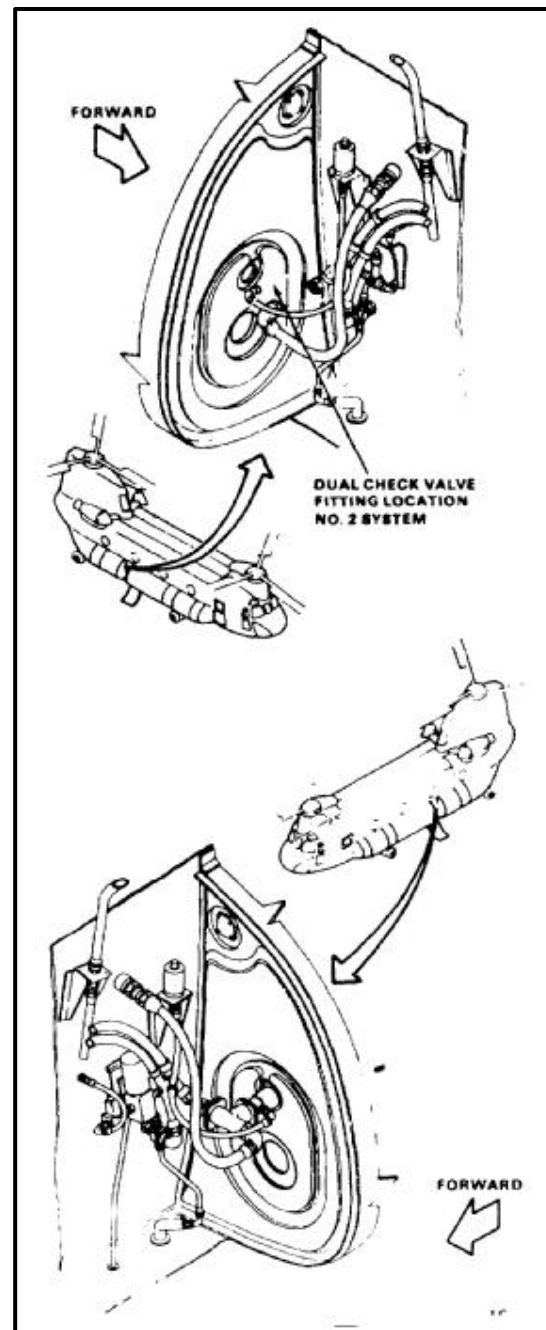

CAUTION

Do not allow dual check valve breakaway fitting (1) to turn within its mounting when connecting fuel and pressure lines. Otherwise valve can fail and cause fuel blockage.

NOTE

Procedure is same to install No. 1 or No. 2 system dual check valve fittings. No. 2 system fitting is shown here.

1. Install four-bolt flange (2) of dual check valve breakaway fitting (1) in tank access door (3). Check that ends of fitting are in position to accept fuel and pressure lines without turning fitting in its mounting.
2. Remove caps from fitting (1) ends.
3. Install dual check valve breakaway fitting (1) in tank access door (3). Use four screws (4) and washers (5).
4. Remove plugs from fuel hose (6 and 7) fittings. Install conical seals (8 and 9) in hose fittings. Hold dual check valve breakaway fitting (1) with a strap wrench and connect hoses.
5. Remove plug from pressure hose (10) fitting. Hold dual clock valve breakaway fitting (1) with a strap wrench and connect hose.
6. Remove plug from fuel hose (12) fitting (inside aft fuel tank). Hold dual check valve breakaway fitting (1) with a strap wrench and connect hose.

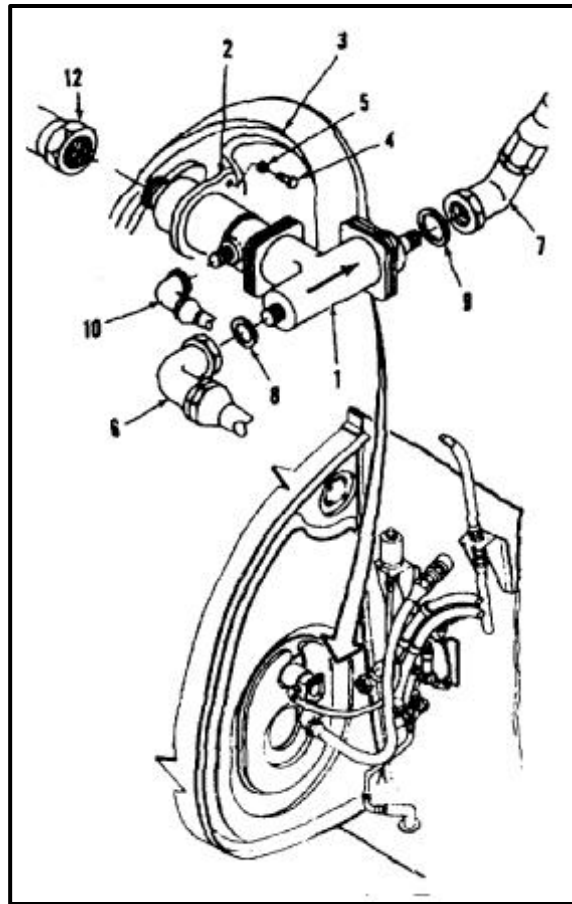

INSPECT

FOLLOW-ON MAINTENANCE:

- Refuel aircraft (Task 1-51).
- Bleed fuel system (Task 10-121).
- Perform operational check of fuel system (TM 55-1520-240-T).
- Check for leaks (Task 10-4).
- Close aft intertank access door (Task 2-188).

END OF TASK

10-97 REMOVE APU FUEL BOOST PUMP**10-97****INITIAL SETUP****Applicable Configurations:**

All

Tools

Aircraft Mechanic's Tool Kit, NSN 5180-00-323-4692
 Grounded Container, 2 Quart or Equivalent

Materials:

Cloths (E135)
 Paper Tags (E264)

Personnel Required:

Medium Helicopter Repairer

Equipment Condition:

Battery Disconnected (Task 1-39)
 Electrical Power Off
 Helicopter Grounded (Task 1-29)
 Left Aft Intertank Bay Access Door Open (Task 2-185)

General Safety Instructions:**WARNING**

All regulations and instructions
 for handling fuels shall be strictly
 observed.

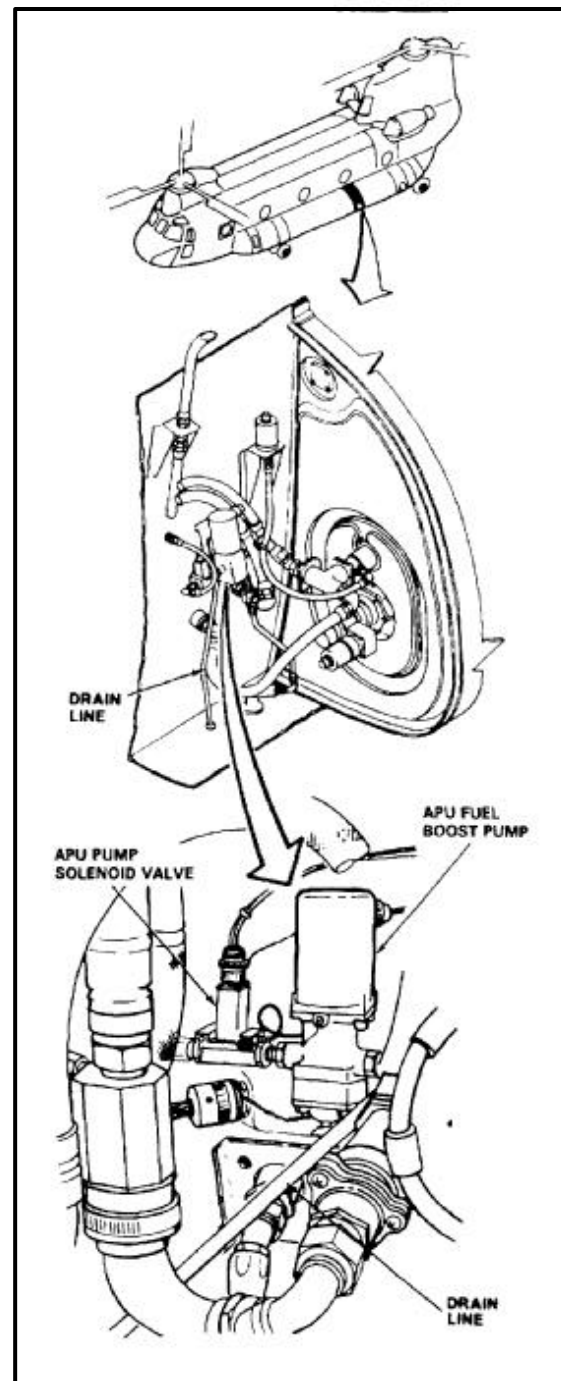

1. Tag and disconnect two electrical connectors (1) from pump (2) and solenoid valve (3).
2. Tag and disconnect two fuel hoses (4). Plug hose connectors.
3. Remove four screws (5) and washers (6). Disconnect electrical lead (7).
4. Remove pump (2) and solenoid valve (3). Use container and cloths (E135) for any spilled fuel.

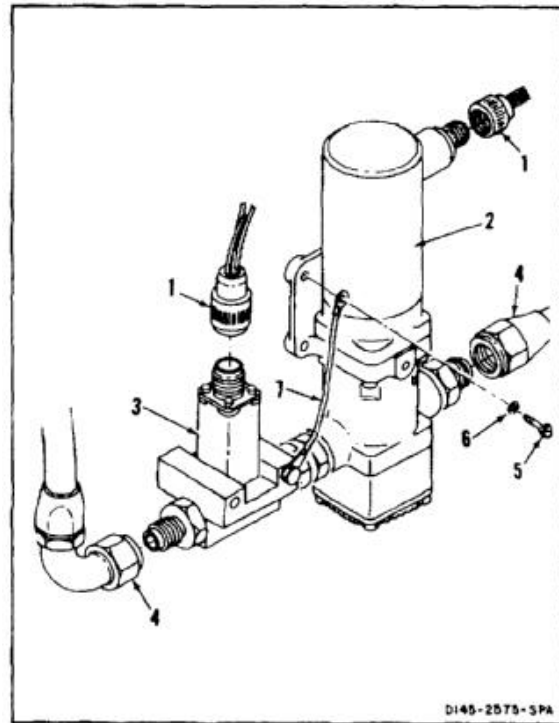

5. Loosen nut (8).
6. Hold nipple (9) with wrench. Remove solenoid valve (3) and packing (10). Use wrench on flats of solenoid valve.
7. Plug valve (3).
8. Remove two nipples (9 and 11), packings (12 and 13) and nut (8). Plug ports in pump.

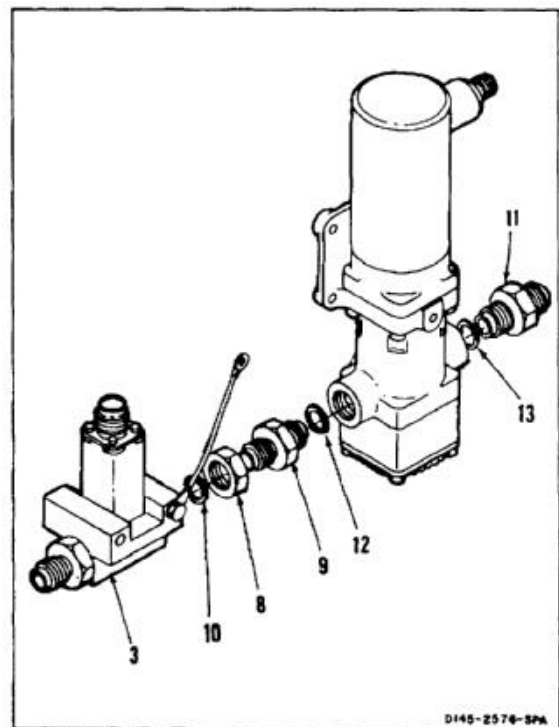

10-97 REMOVE APU FUEL BOOST PUMP (Continued)**10-97**

9. Loosen nut (14).
10. Hold elbow (15) with wrench. Tag and disconnect drain tube (16). Plug tube connectors.

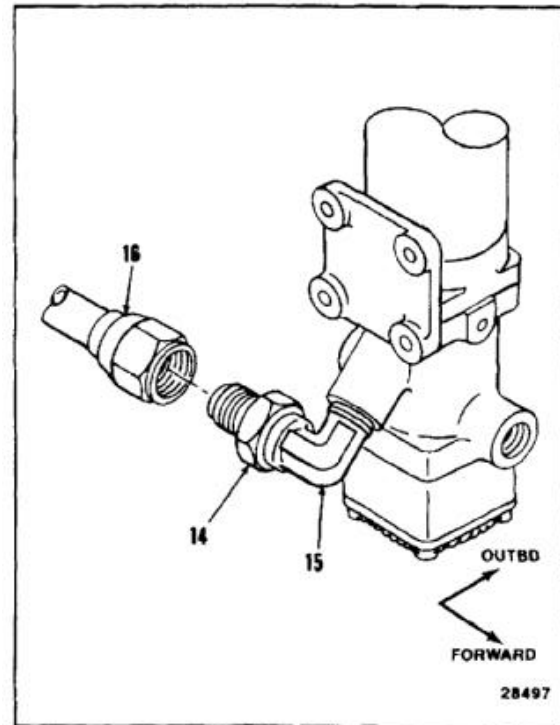
***FOLLOW-ON MAINTENANCE:***

None

END OF TASK

INITIAL SETUP

Applicable Configurations:

All

Tools:

Aircraft Mechanic's Tool Kit, NSN 5180-00-323-4692

Materials:

None

Parts:

Packings

Personnel Required:Medium Helicopter Repairer
Inspector**References:**

TM 55-1520-240-23P

General Safety Instructions:**WARNING**

All regulations and instructions for handling fuels shall be strictly observed.

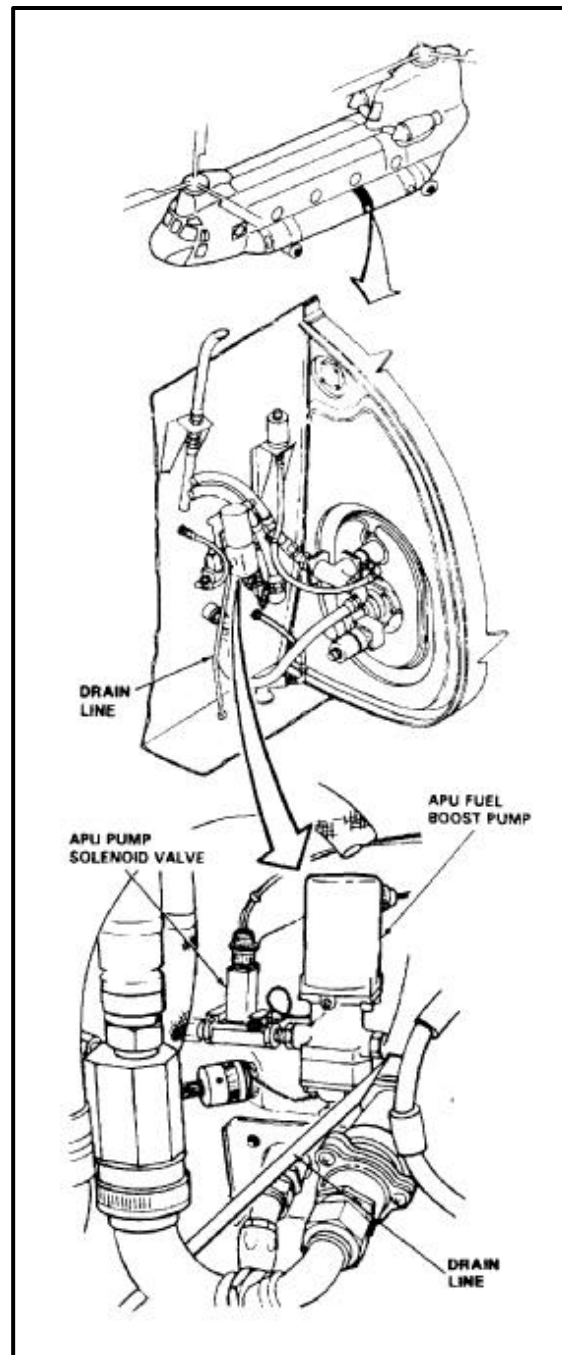

1. Remove plugs from pump (1) and install nipples (2 and 3), and packings (4 and 5) in pump.
2. Install locknut (6) and packing (7) on nipple (3).
3. Remove plug from solenoid valve (8). Hold nipple (3) with wrench. Install solenoid valve on nipple with valve. Tighten nut (6), with valve aligned with pump (1) as shown.

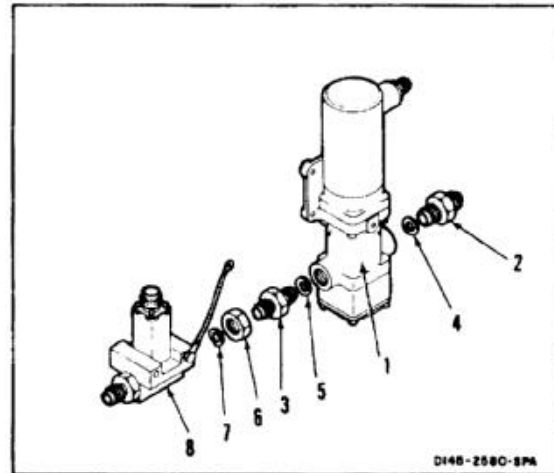

4. Position pump (1) on fuselage mounting bracket (9). Install electrical lead (10), four washers (11) and screws (12).
5. Remove plug from fuel hose (13) and cap from solenoid valve (8). Install fuel hose on solenoid valve. Remove tag.
6. Remove plug from fuel hose (14). Install fuel hose on pump (1). Remove tag.
7. Connect electrical connectors (15 and 16). Remove tags.

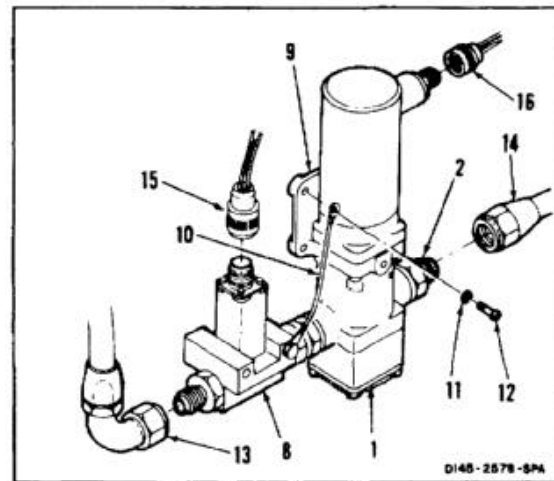

8. Remove tag and plug from drain tube (17). Hold elbow (18) with wrench. Install drain tube on elbow. Tighten nut (19).

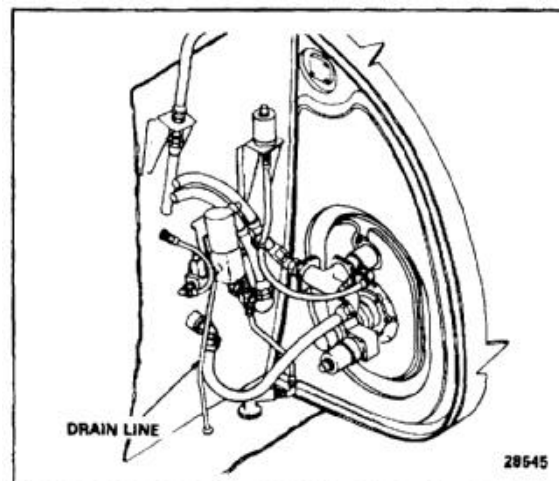
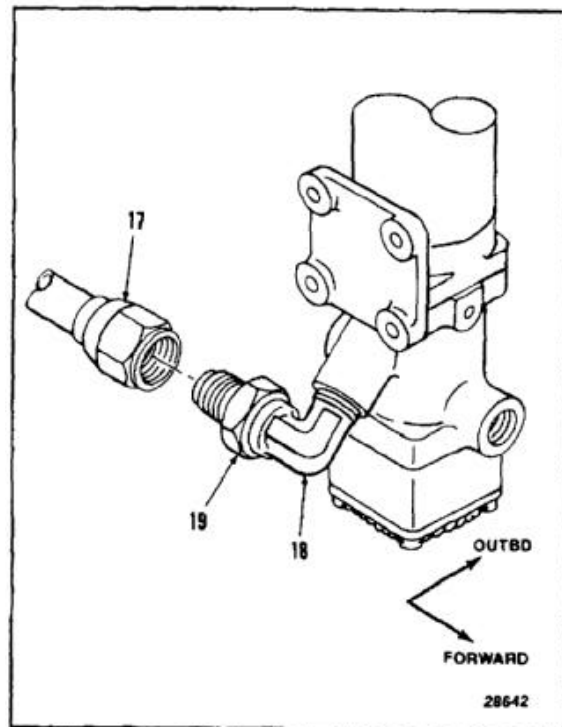

INSPECT

FOLLOW-ON MAINTENANCE:

- Perform operational check of APU (TM 55-1520-240-T).
- Check APU fuel boost pump for leaks.
- Close left aft intertank bay access door (Task 2-188).

END OF TASK

10-460

10-99 REMOVE APU FUEL SOLENOID VALVE**10-99****INITIAL SETUP****Applicable Configurations:**

All

Tools:

Aircraft Mechanic's Tool Kit, NSN 5180-00-323-4692
 Grounded Container, 2 Quart or Equivalent

Materials:

Cloths (E135)

Personnel Required:

Medium Helicopter Repairer

Equipment Condition:

Battery Disconnected (Task 1-39)
 Electrical Power Off
 Helicopter Grounded (Task 1-29)
 Left Aft Intertank Bay Access Door Open (Task 2-185)

General Safety Instructions:**WARNING**

All regulations and instructions
 for handling fuels shall be strictly
 observed.

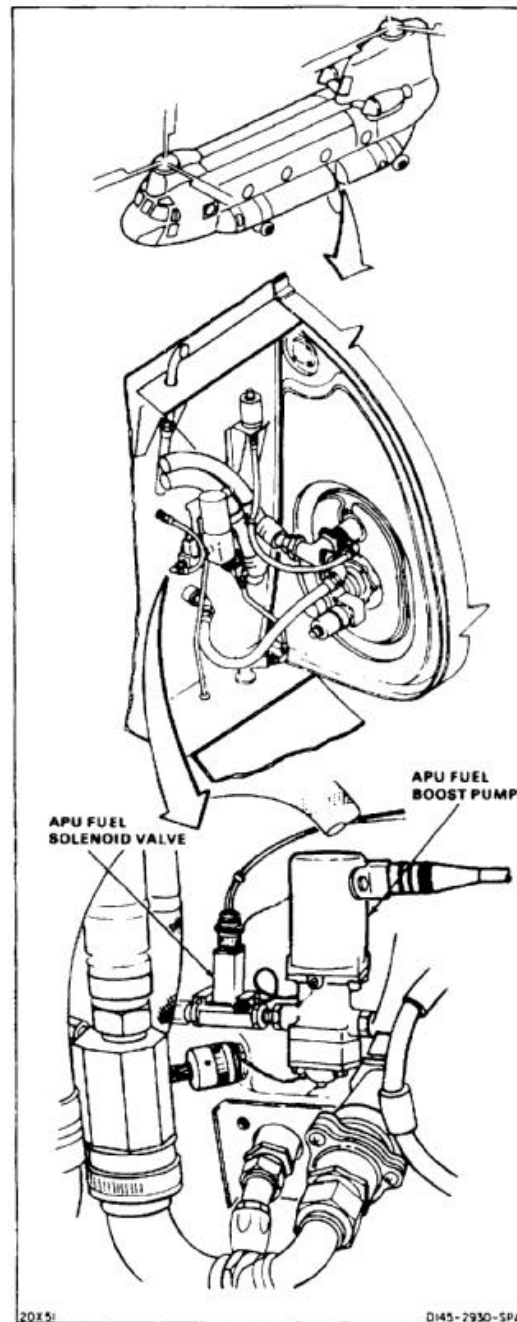

1. Place container under pump (1) to catch spilled fuel.
2. Disconnect electrical connector (2).
3. Remove lockwire and disconnect electrical connector (3).
4. Disconnect fuel hose (4). Plug hose connector. Cap nipple (5) in pump (1).
5. Disconnect fuel hose (6). Plug hose connector. Cap elbow (8).
6. Disconnect drain hose (7). Plug hose connector. Cap elbow (8).
7. Remove four screws (9) and four washers (10). Disconnect electrical lead (11).
8. Remove pump (1) and solenoid valve (12).
9. Wipe up spilled fuel. Use cloths (E135).

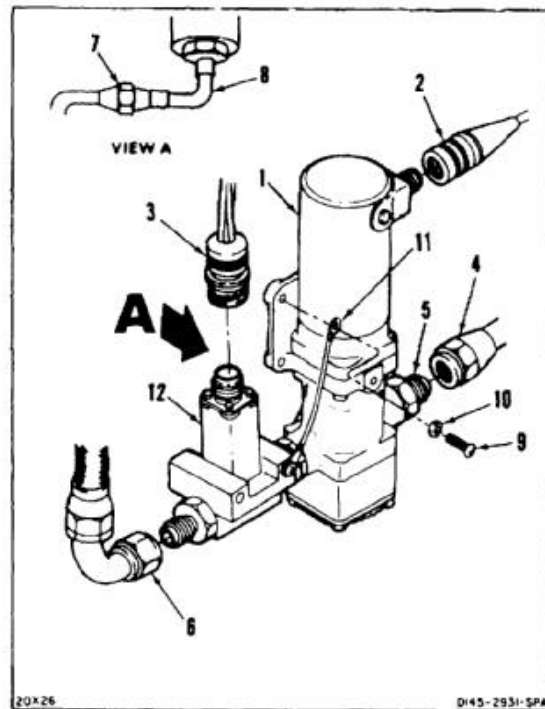

10. Loosen locknut (13).
11. Hold nipple (14) with wrench. Use wrench on flats of valve (12). Remove valve, packing (15) and locknut (13).
12. Plug port in valve (12) and cap nipple (14).
13. Remove nipple (16) and packing (17). Plug port in valve (12).
14. Remove screw (18), washer (19) and electrical lead (11).

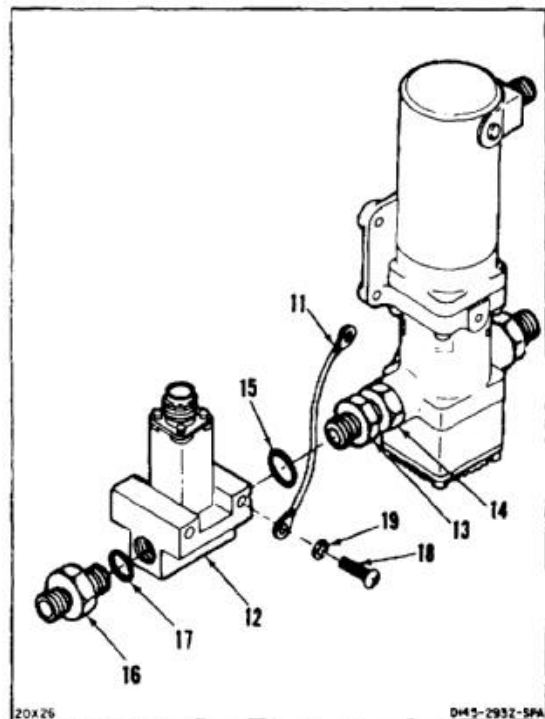

FOLLOW-ON MAINTENANCE:

None

END OF TASK

10-462

INITIAL SETUP

Applicable Configurations:

All

Tools:

Aircraft Mechanic's Tool Kit, NSN 51 80-00-323-4692

Materials:

Lockwire (E229)

Parts:

Packings

Personnel Required:Medium Helicopter Repairer
Inspector**References:**

TM 55-1520-240-23P

General Safety Instructions:**WARNING**

All regulations and instructions for handling fuels shall be strictly observed.

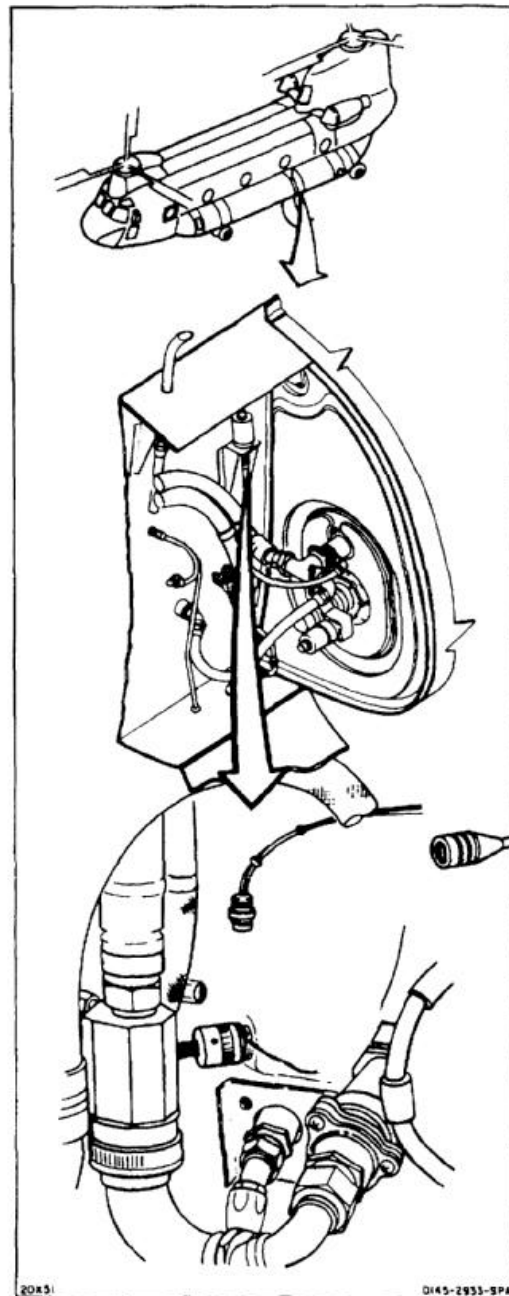

1. Connect electrical lead (1) by installing washer (2) and screw (3) in valve (4).
2. Remove plugs from valve (4).
3. Install nipple (5) and packing (6) on valve (4).
4. Remove cap from nipple (7). Install locknut (8) and packing (9) on nipple (7).
5. Hold nipple (7) with wrench. Install solenoid valve (4) on nipple (7). Align valve (4) with pump (10) and tighten locknut (8).

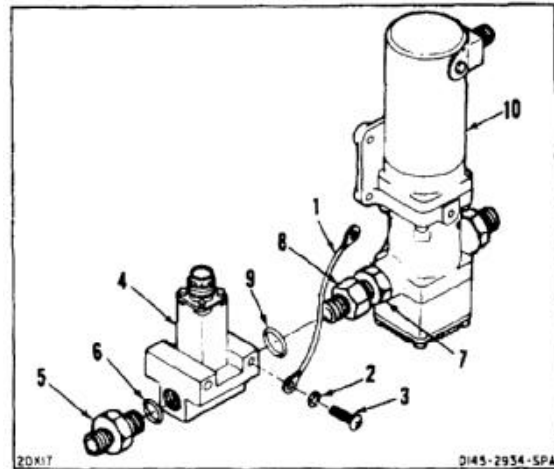

6. Position pump (10) on bracket (11). Install electrical lead (1) and four washers (12) and screws (13).
7. Remove plug from fuel hose (14) and cap from elbow (15). Connect fuel hose (14) to elbow (15).
8. Remove plug from fuel hose (16) and cap from nipple (5). Connect hose to nipple.
9. Remove plug from hose (17) and cap from nipple (18). Connect hose to nipple.
10. Connect electrical connector (19) to valve (4). Lockwire connector to valve. Use lockwire (E229).
11. Connect electrical connector (20) to pump (10).

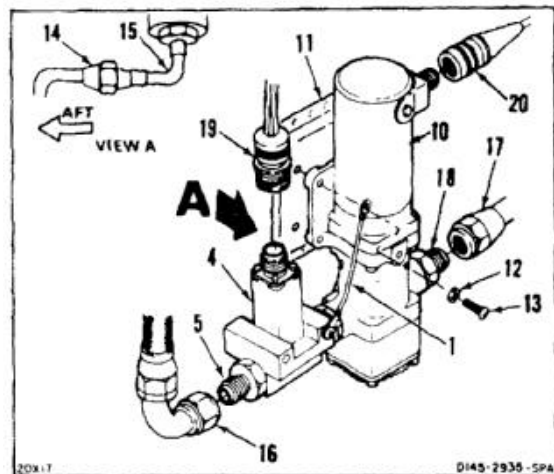
**INSPECT****FOLLOW-ON MAINTENANCE:**

- Perform operational check of fuel system (TM 55-1520-240-T).
- Inspect for leaks (Task 10-4).
- Close left aft intertank bay access door (Task 2-188).

END OF TASK

10-101 REMOVE APU FUEL SHUTOFF MANUAL VALVE**10-101****INITIAL SETUP****Applicable Configurations:**

All

Tools:

Aircraft Mechanic's Tool Kit, NSN 5180-00-323-4692
 Grounded Container, 2 Quart or Equivalent

Materials:

Cloths (E135)

Personnel Required:

Medium Helicopter Repairer

Equipment Condition:

Battery Disconnected (Task 1-39)
 Electrical Power Off
 Helicopter Grounded (Task 1-29)

General Safety Instructions:**WARNING**

All regulations and instructions
 for handling fuels shall be strictly
 observed.

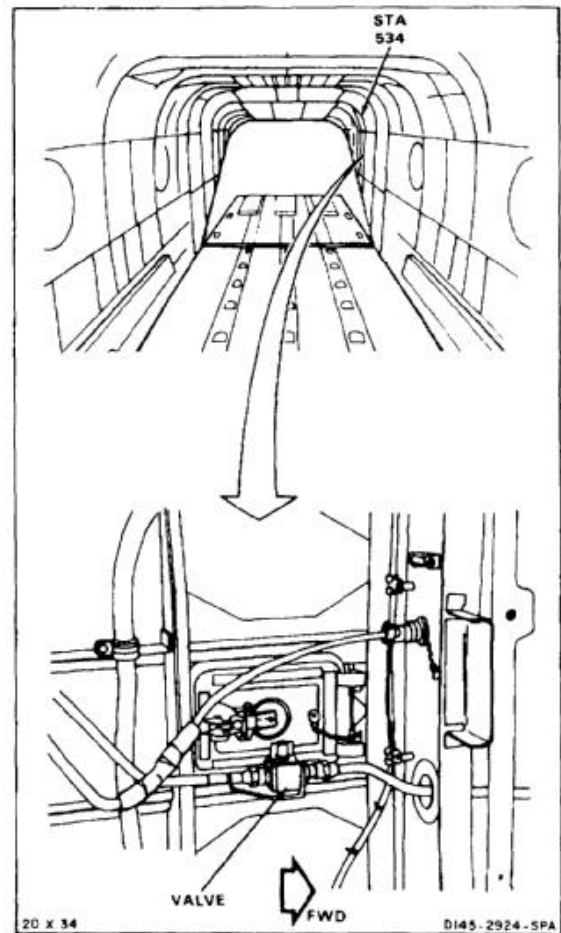

1. Disconnect two fuel connectors (1) from shutoff valve (2). Use container for spilled fuel. Plug fuel tubes.
2. Remove nut (3) and washer (4).
3. Remove valve (2). Cap valve connectors.
4. Wipe up any spilled fuel. Use cloths (E135).

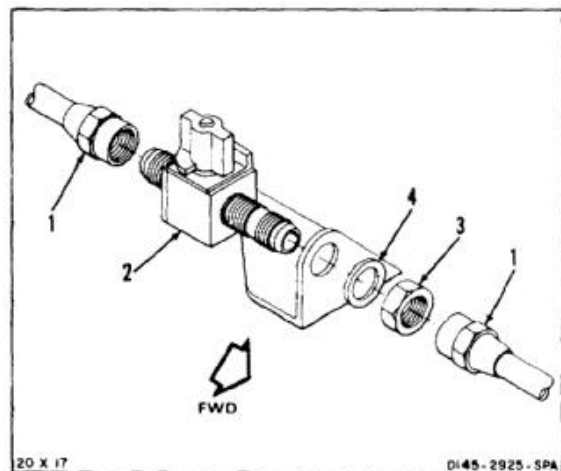
**FOLLOW-ON MAINTENANCE:**

None

END OF TASK

INITIAL SETUP

Applicable Configurations:

All

Tools:

Aircraft Mechanic's Tool Kit, NSN 5180-00-323-4692

Materials:

None

Personnel Required:Medium Helicopter Repairer
Inspector**References:**

TM 55-1520-240-23P

General Safety Instructions:**WARNING**

All regulations and instructions for handling fuels shall be strictly observed.

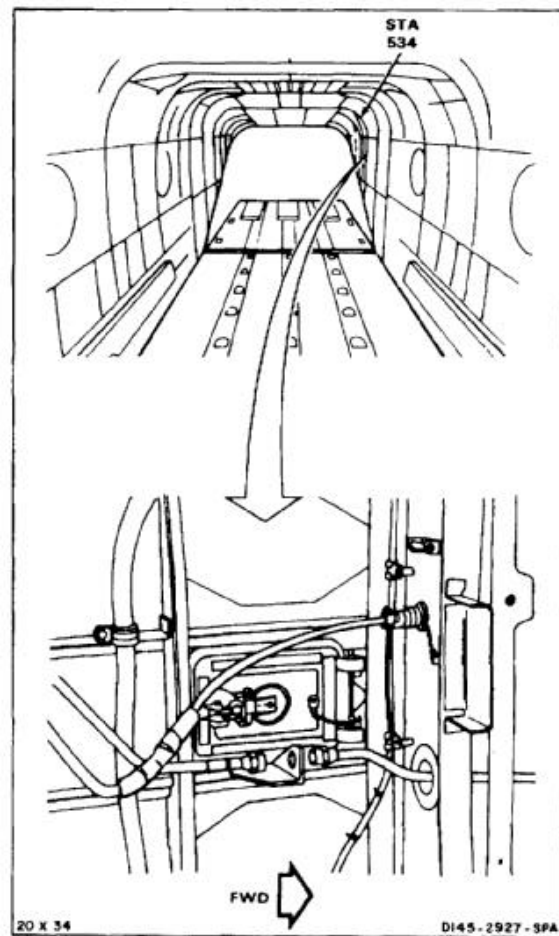

1. Remove caps from valve (1).
2. Position INLET connector (2) of valve (1) through hole in bracket (3). Make sure valve handle (4) is on top.
3. Install washer (5) and nut (6).
4. Remove plugs from fuel connectors (7). Connect two fuel connectors to valve (1).

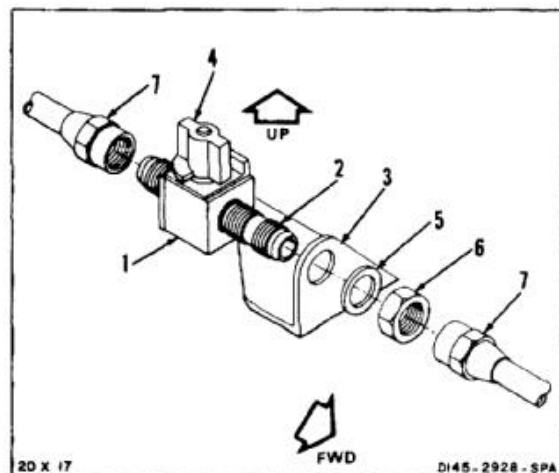
INSPECT**FOLLOW-ON MAINTENANCE:**

Perform APU operational check (TM 55-1520-240-T).
Check for leaks (Task 10-4).

END OF TASK

10-466

INITIAL SETUP

Applicable Configurations:

All

Tools:

Aircraft Mechanic's Tool Kit, NSN 5180-00-323-4692
 Crowsfoot, 2 Inch
 Wrench, Open End, 1-1/2 Inch
 Grounded Container, 2 Quart or Equivalent

Materials:

Cloths (E135)

Personnel Required:

Medium Helicopter Repairer

Equipment Condition:

Battery Disconnected (Task 1-39)
 Electrical Power Off
 Helicopter Grounded (Task 1-29)
 Both Crossover Valves and Engine Fuel Valves
 Closed (TM 55-1520-240-T)

General Safety Instructions:**WARNING**

All regulations and instruction
 for handling fuels shall be strictly
 observed.

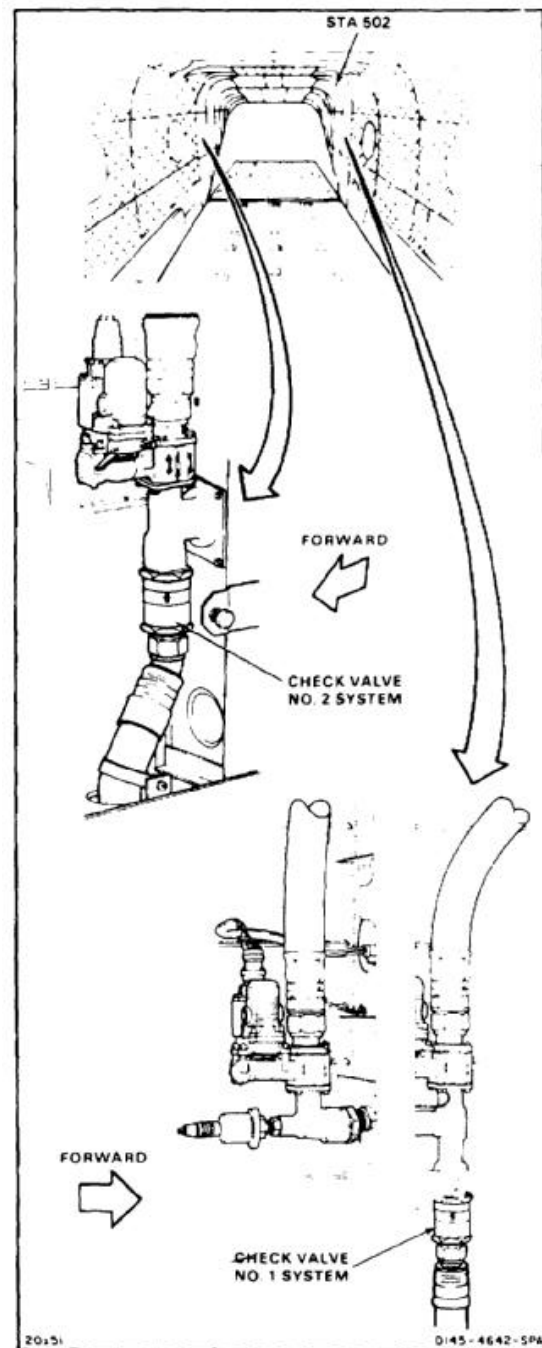

NOTE

Procedure is same to remove No. 1 or No. 2 engine fuel line check valves. No. 2 check valve is shown here.

1. Remove nut (1), washers (2) and bolt (3) from clamp (4). Remove clamp.
2. Disconnect hose (5) from check valve (6). Use wrench on flats of fitting (7) to prevent valve from turning. Use container to catch spilled fuel. Plug hose.
3. Remove check valve (6) from fitting (8) using wrench on flats of fitting (9). Support fitting with wrench on flats. Plug fitting.
4. Remove packing (10) from fitting (9).
5. Clean up any spilled fuel. Use cloths (E135).

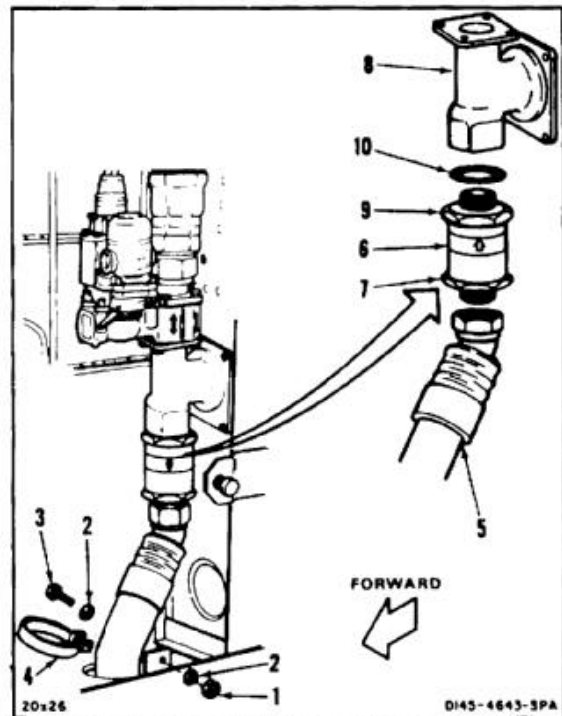
**FOLLOW-ON MAINTENANCE:**

None

END OF TASK

10-468

INITIAL SETUP

Applicable Configurations:

All

Tools:

Aircraft Mechanic's Tool Kit, NSN 51 80-00-323-4692
 Wrench, Open End, 1-1/2 Inch
 Crowfoot Attachment, 2 Inches

Materials:

None

Parts:

Packing

Personnel Required:

Medium Helicopter Repairer
 Inspector

References:

TM 55-1520-240-23P

General Safety Instructions:**WARNING**

All regulations and instruction
 for handling fuels shall be strictly
 observed.

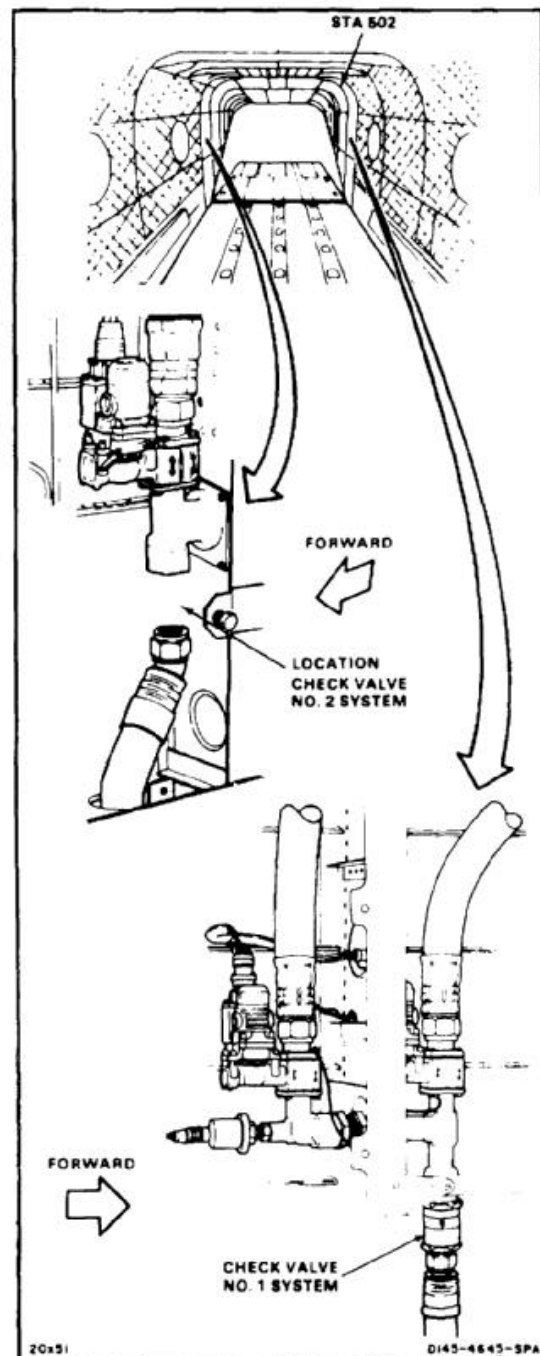

NOTE

Procedure is same to install No. 1 or No. 2 engine fuel line check valves. No. 2 check valve is shown here.

1. Install packing (1) on fitting (2).
2. Remove plug from fitting (3). Install check valve (4) in fitting, flow arrow towards fitting. Hold fitting with wrench on flats. Tighten check valve using flats on fitting (2).
3. Remove plug from hose (5). Connect hose to valve (4). Support fitting (6) with wrench on flats while tightening hose.
4. Position clamp (7) on hose (5). Install bolt (8), washers (9), and nut (10).

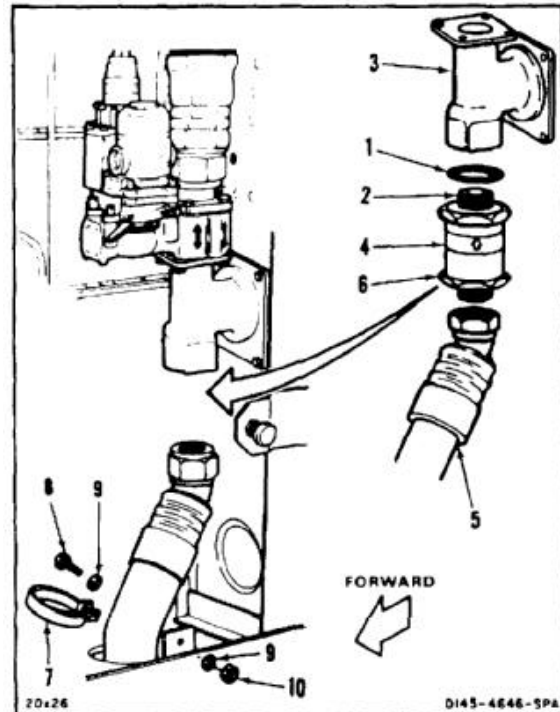
**INSPECT****FOLLOW-ON MAINTENANCE:**

- Bleed fuel system (Task 10-121).
- Perform operational check of fuel system (TM 55-1520-240-T).
- Check for leaks (Task 10-4).

END OF TASK

10-470

INITIAL SETUP

Applicable Configurations:

All

Tools:

Aircraft Mechanic's Tool Kit, NSN 5180-00-323-4692
 Grounded Container, 2 Quart or Equivalent

Materials:

Cloths (E135)

Personnel Required:

Medium Helicopter Repairer

Equipment Condition:

Battery Disconnected (Task 1-39)
 Electrical Power Off
 Helicopter Grounded (Task 1-29)

General Safety Instructions:**WARNING**

All regulations and instructions
 for handling fuels shall be strictly
 observed.

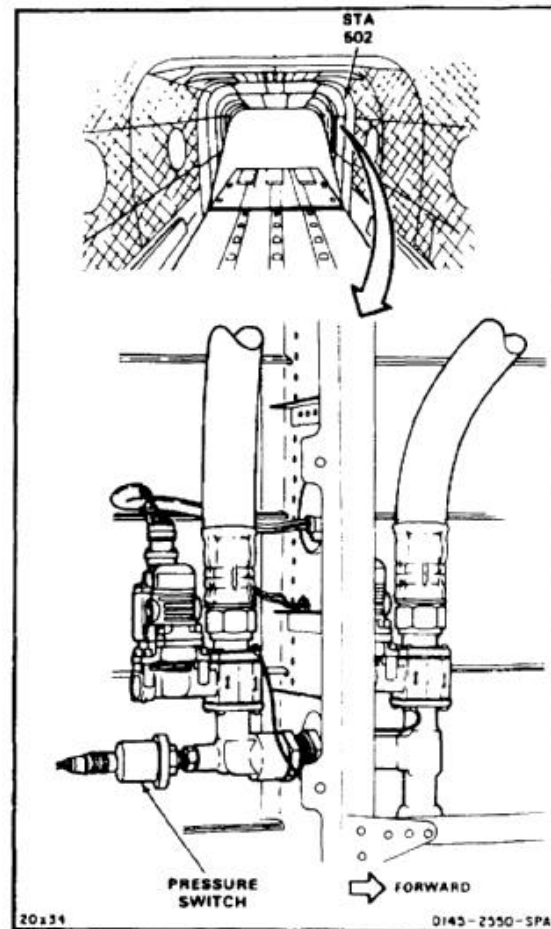

1. Disconnect cable plug (1).
2. Loosen nut (2) on switch (3).
3. Hold tee (4) with wrench and remove switch (3) and packing (5). Use wrench on flats (6). Use container for spilled fuel.
4. Remove nut (2) from switch (3).
5. Plug tee (4).
6. Clean up any spilled fuel. Use cloths (E135).

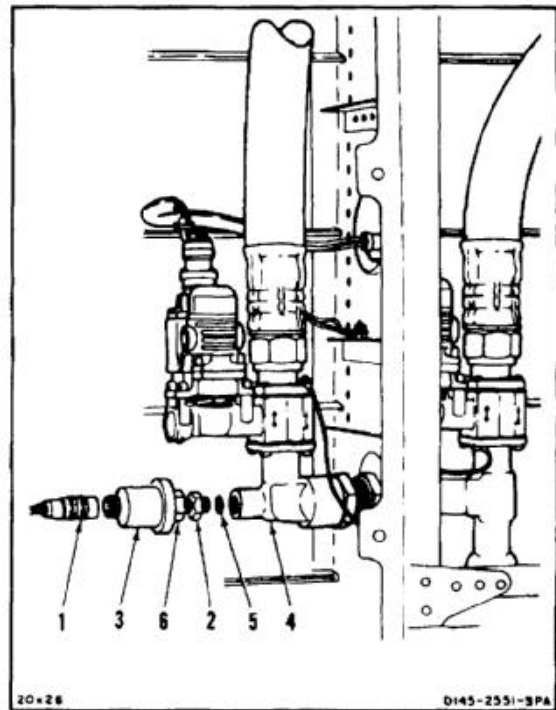
***FOLLOW-ON MAINTENANCE:***

None

END OF TASK

10-472

INITIAL SETUP

Applicable Configurations:

All

Tools:

Aircraft Mechanic's Tool Kit, NSN 51 80-00-323-4692

Materials:

None

Parts:

Packing

Personnel Required:Medium Helicopter Repairer
Inspector**References:**

TM 55-1520-240-23P

General Safety Instructions:**WARNING**

All regulations and instructions for handling fuels shall be strictly observed.

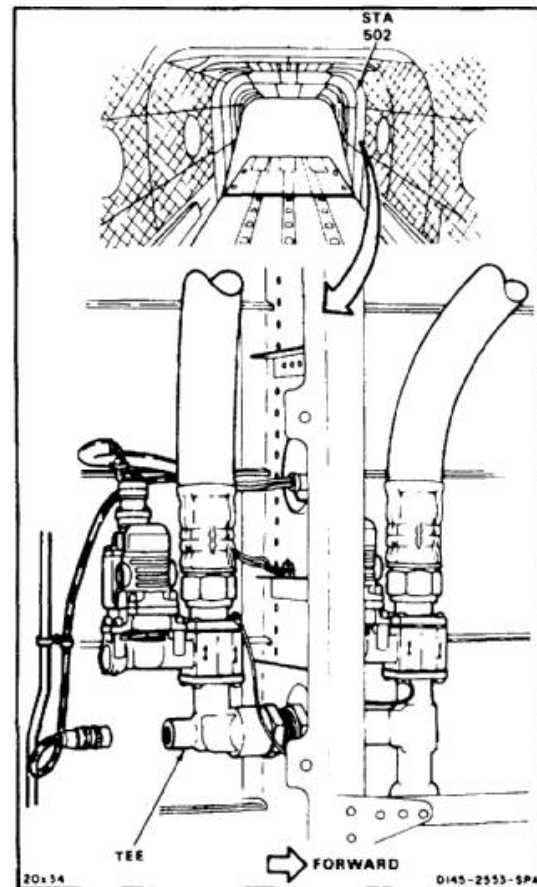

1. Remove plug from tee (1).
2. Install nut (2) and packing (3) on switch (4).
3. Hold tee (1) with wrench. Install switch (4) in tee (1). Use wrench on flats (5).
4. Tighten nut (2).
5. Connect cable (6) to switch (4).

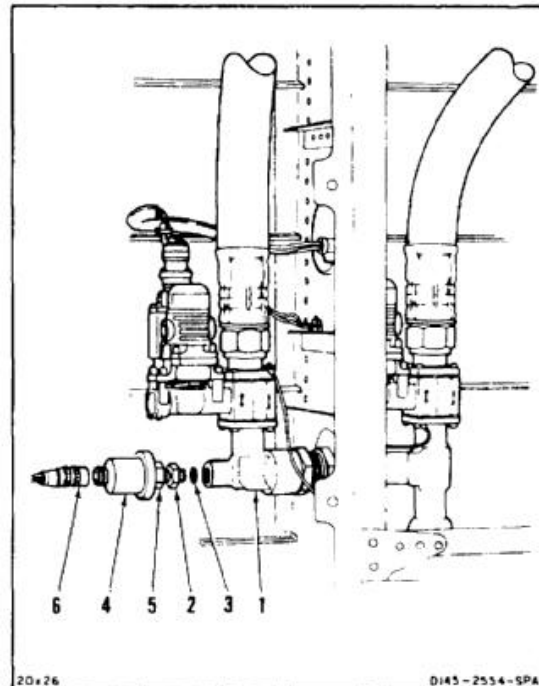
INSPECT**FOLLOW-ON MAINTENANCE:**

- Perform operational check (TM 55-1520-240-T).
- Perform test of fuel feed system (Task 10-120).

END OF TASK

10-474

10-107 REMOVE NO. 2 FUEL SYSTEM PRESSURE SWITCH (RIGHT SIDE)**10-107****INITIAL SETUP****Applicable Configurations:**

All

Tools:

Aircraft Mechanic's Tool Kit, NSN 5180-00-323-4692
 Grounded Container, 2 Quart or Equivalent

Materials:

Cloths (E135)
 Twine (E433)

Personnel Required:

Medium Helicopter Repairer

Equipment Condition:

Battery Disconnected (Task 1-39)
 Electrical Power Off
 Helicopter Grounded (Task 1-29)

General Safety Instructions:**WARNING**

All regulations and instructions
 for handling fuels shall be strictly
 observed.

1. Disconnect cable plug (1). Tie to adjacent structure. Use twine (E433).
2. Loosen nut (2) on switch (3).
3. Hold tee (4) with wrench and remove switch (3) and packing (5). Use wrench on flats (6). Use container for spilled fuel.
4. Remove nut (2) from switch (3).
5. Plug tee (4).
6. Clean up any spilled fuel. Use cloths (E135).

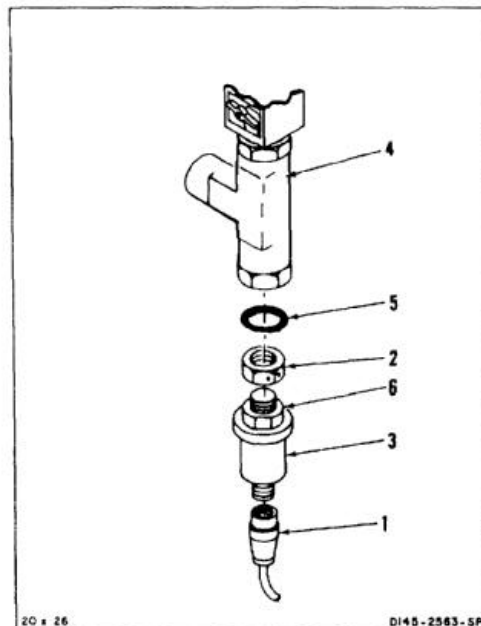
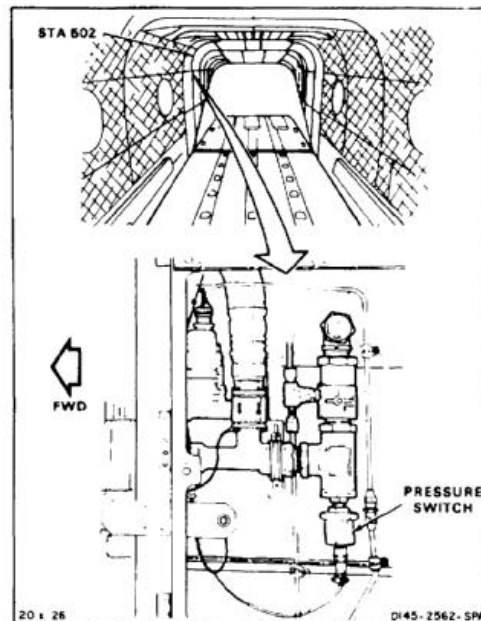
**FOLLOW-ON MAINTENANCE:**

None

END OF TASK

INITIAL SETUP

Applicable Configurations:

All

Tools:

Aircraft Mechanic's Tool Kit, NSN 5180-00-323-4692

Materials:

None

Parts:

Packing

Personnel Required:Medium Helicopter Repairer
Inspector**References:**

TM 55-1520-240-23P

General Safety Instructions:**WARNING**

All regulations and instructions for handling fuels shall be strictly observed.

1. Remove plug from tee (1).
2. Install nut (2) and packing (3) on switch (4).
3. Hold tee (1) with wrench. Install switch (4) on tee (1). Use wrench on flats (5).
4. Tighten nut (2).
5. Connect cable plug (6) to switch (4).

INSPECT**FOLLOW-ON MAINTENANCE:**

Perform test of fuel feed system (Task 10-120).
Perform operational check of No. 2 fuel system (TM 55-1520-240-T).

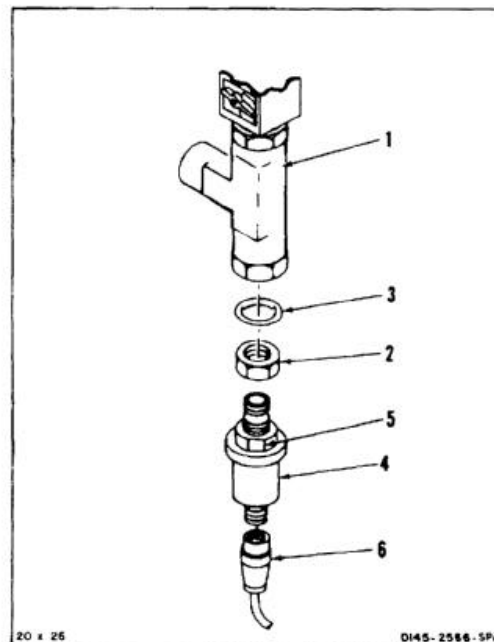
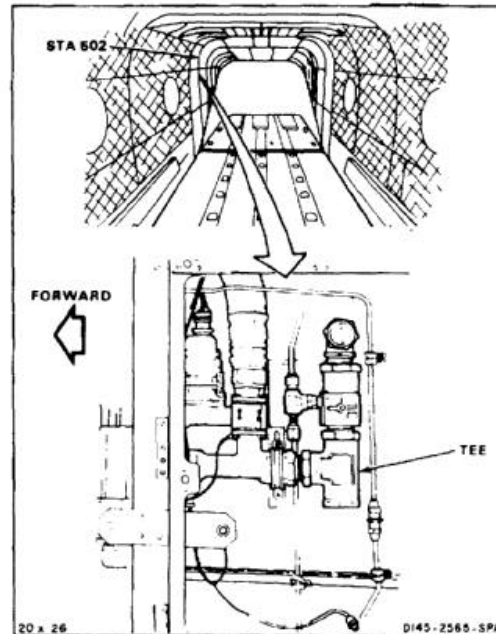

END OF TASK

10-476

10-109 REMOVE DEFUELING MANUAL VALVE**10-109****INITIAL SETUP****Applicable Configurations:**

All

Tools:

Aircraft Mechanic's Tool Kit, NSN 5180-00-323-4692
 Wrench, Open End, 1-5/8 Inch
 Wrench, Open End, 1-1/2 Inch
 Grounded Container, 2 Quart or Equivalent

Materials:

Cloths (E135)

Personnel Required:

Medium Helicopter Repairer

Equipment Condition:

Battery Disconnected (Task 1-39)
 Electrical Power Off
 Helicopter Grounded (Task 1-29)

General Safety Instructions:**WARNING**

All regulation and instructions
 for handling fuels shall be strictly
 observed.

1. Remove cap (1) from elbow (2).
2. Turn valve knob (3) counterclockwise to vertical position. Drain fuel. Use container for fuel.

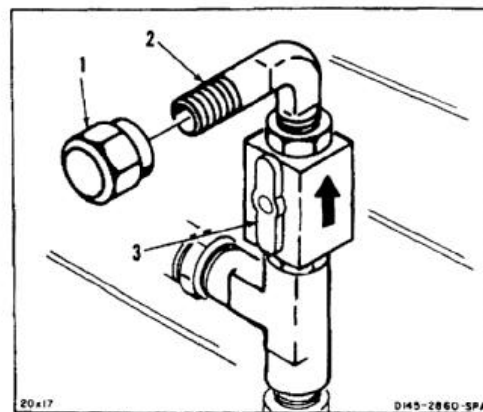
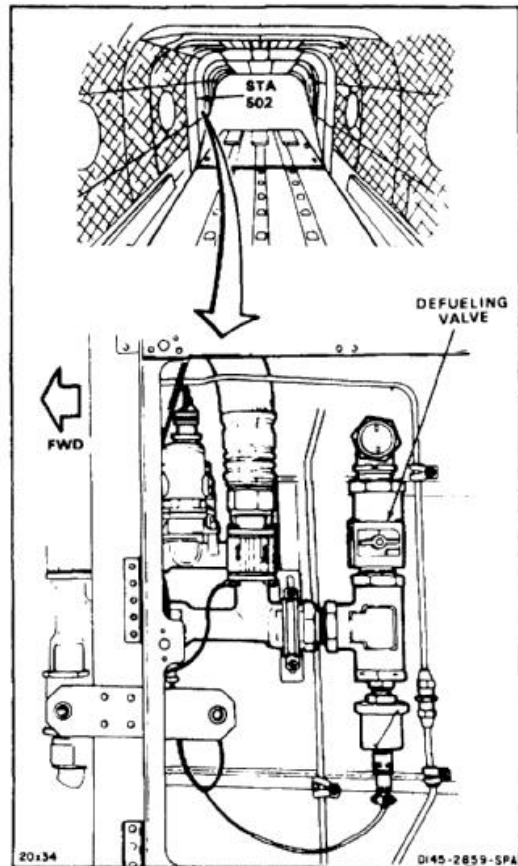

3. Loosen nut (4). Tilt tee (5) inboard.

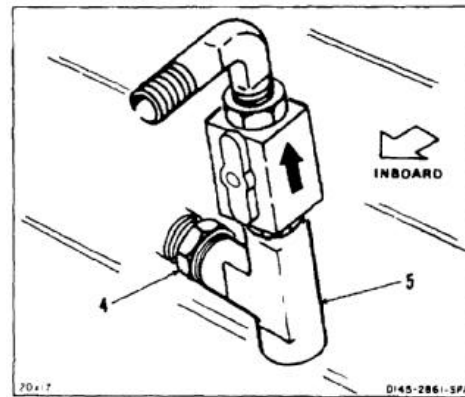

4. Loosen nut (6). Remove elbow (2) and packing (7).

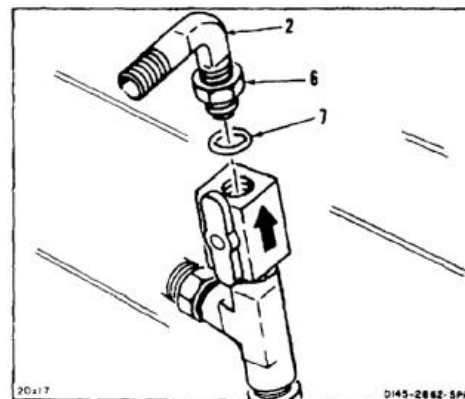

5. Hold tee (5) with wrench. Loosen nut (8). Remove valve (9) and packing (10). Plug tee.
6. Clean up any spilled fuel. Use cloths (E135).

FOLLOW-ON MAINTENANCE:

None

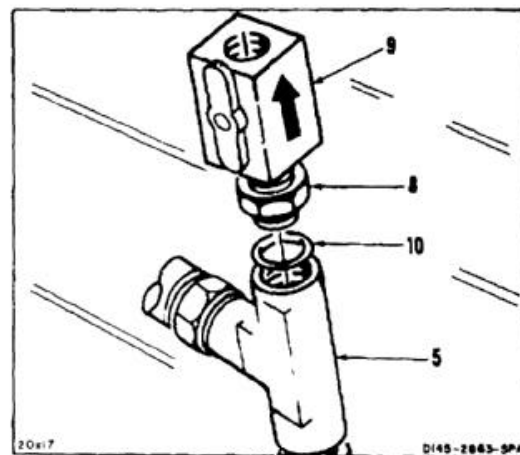

END OF TASK

10-478

INITIAL SETUP

Applicable Configurations:

All

Tools:

- Aircraft Mechanic's Tool Kit, NSN 51 80-00-323-4692
- Wrench, Open End, 1-5/8 Inch
- Wrench, Open End, 1-1/2 Inch

Materials:

None

Parts:

Packings

Personnel Required:

- Medium Helicopter Repairer
- Inspector

References:

TM 55-1520-240-23P

General Safety Instructions:

WARNING

All regulations and instructions for handling fuels shall be strictly observed.

1. Install packing (1) on valve (2) next to nut (3). Turn valve knob (4) to horizontal position as shown.

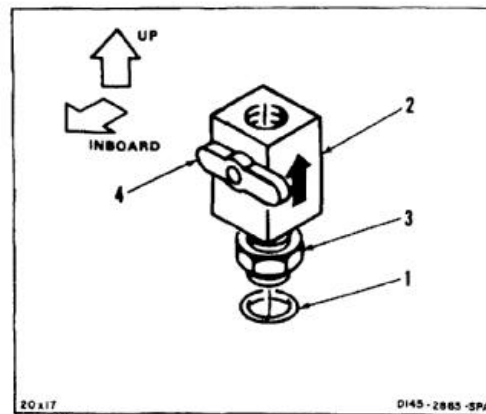
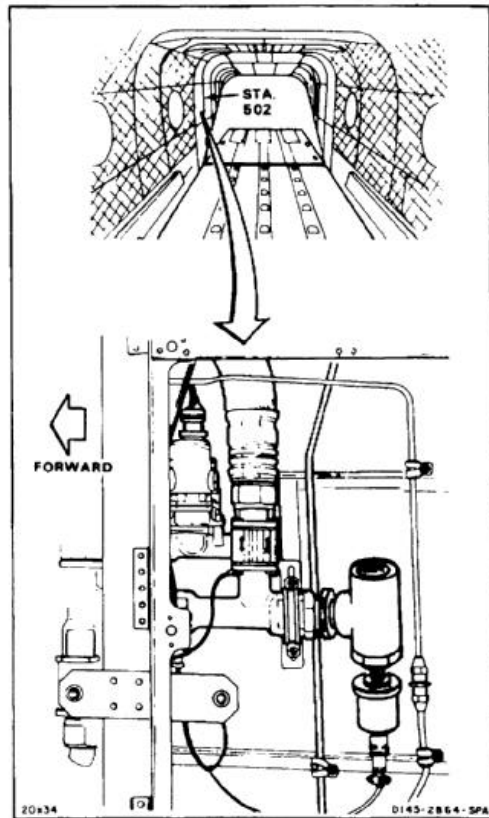

2. Remove plug from tee (5). Install valve (2) on tee so knob (4) faces inboard. Hold tee with wrench. Tighten nut (3).

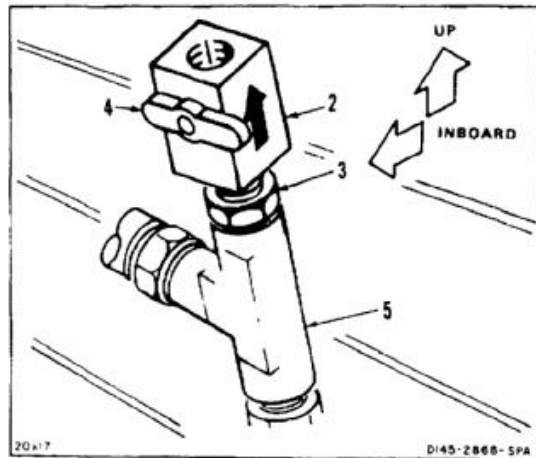

3. Install packing (6) on elbow (7) next to nut (8).

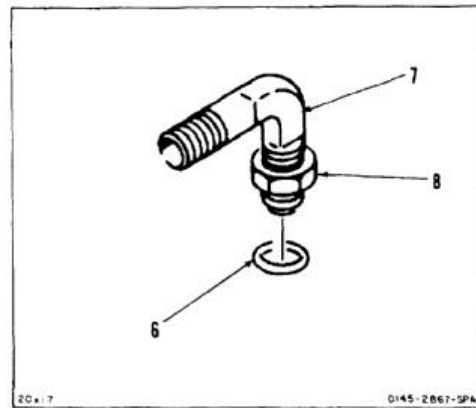

4. Remove plug from valve (2). Install elbow (7) on valve so elbow faces inboard. Hold valve with wrench. Tighten nut (8).

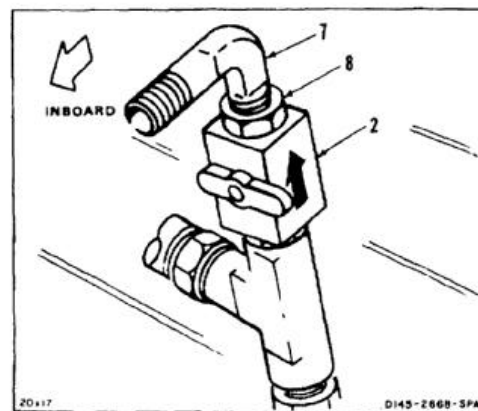

10-110 INSTALL DEFUELING MANUAL VALVE (Continued)**10-110**

5. Tilt tee (5) to vertical position as shown. Tighten nut (10). Install cap (11) on elbow.

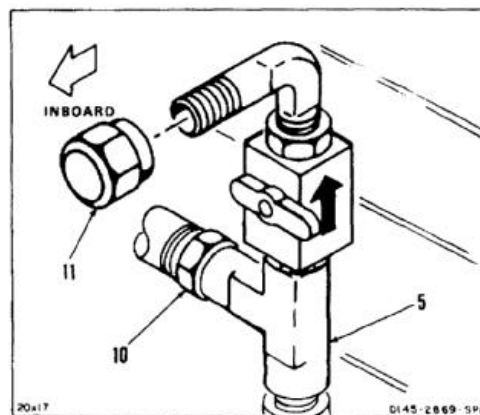
INSPECT**FOLLOW-ON MAINTENANCE:**

- Bleed fuel system (Task 10-121).
- Check for leaks (Task 10-4).

END OF TASK

INITIAL SETUP

Applicable Configurations:

All

Tools:

- Aircraft Mechanic's Tool Kit, NSN 5180-00-323-4692
- Wrench, Open End, 1-5/8 Inch
- Wrench, Open End, 1-1/2 Inch
- Grounded Container, 2 Quart or Equivalent

Materials:

Cloths (E135)

Personnel Required:

Medium Helicopter Repairer

Equipment Condition:

- Battery Disconnected (Task 1-39)
- Electrical Power Off
- Helicopter Grounded (Task 1-29)

General Safety Instructions:

WARNING

All regulations and instructions for handling fuels shall be strictly observed.

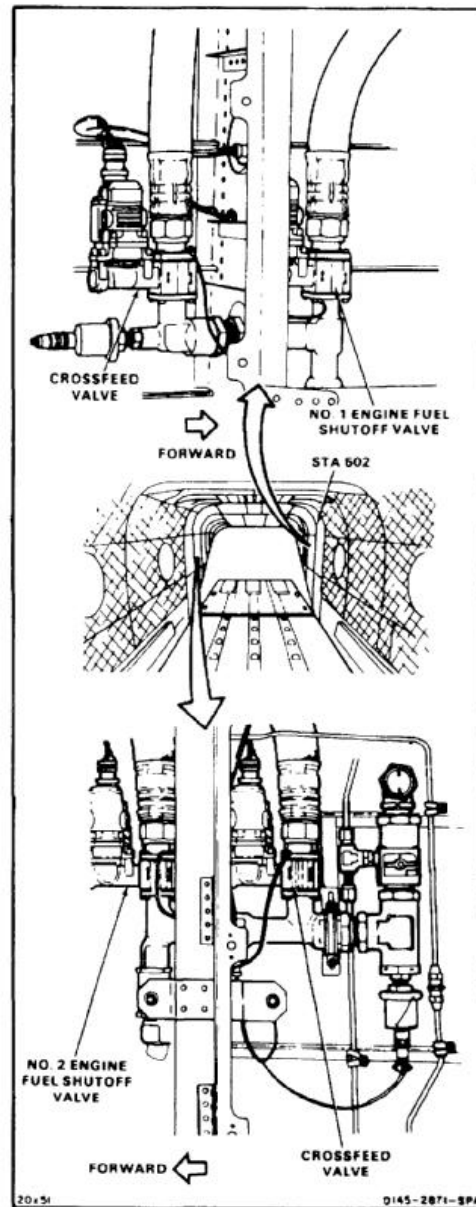

NOTE

There are two engine fuel shutoff valves. Procedure is same to remove either valve. No. 2 (right side) valve is shown here.

1. Make sure manual override crossfeed valve (1) is in CLOSED position.
2. Disconnect electrical cable (2) from valve (3).
3. Remove nut (4), two washers (5), screw (6), electrical load (7) and clip (8).
4. Disconnect hose (9) from adapter (10). Plug hose.
5. Remove nut (11), bolt (12) and electrical lead (13) from flange of tee (14).
6. Remove lockwire, four bolts (15) and washers (16) from valve (3).
7. Remove valve (3) and packing (17). Use container for any spilled fuel.
8. Remove lockwire, four bolts (18), four washers (19) and electrical lead (20) from valve (3). Remove adapter (10) and packing (21).
9. Plug port in tee (14).
10. Wipe up spilled fuel. Use cloths (E135).

FOLLOW-ON MAINTENANCE:

None

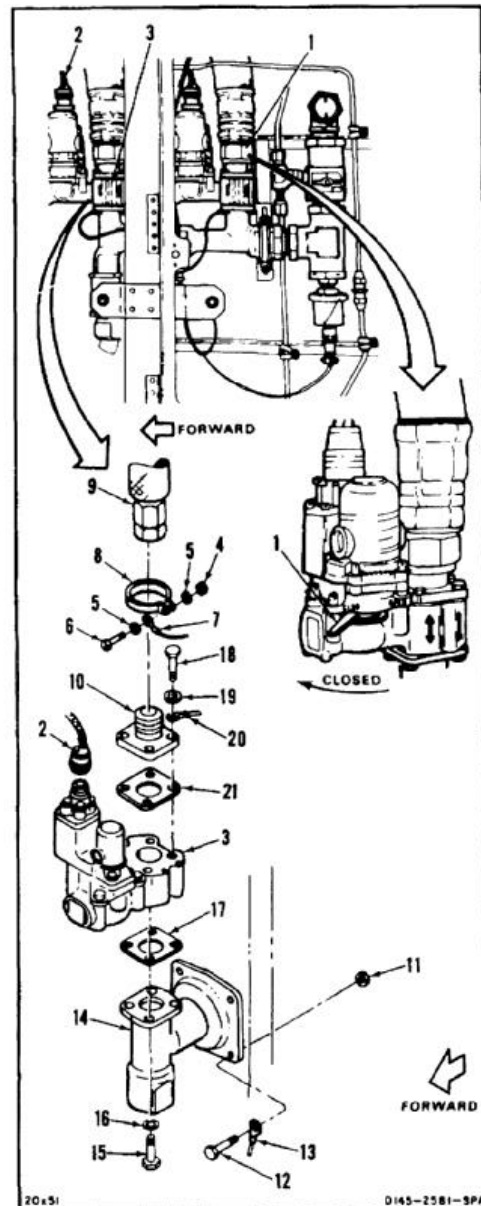

END OF TASK

INITIAL SETUP

Applicable Configurations:

All

Tools:

Aircraft Mechanic's Tool Kit, NSN 5180-00-323-4692
 Torque Wrench, 700 to 1600 Inch-Pounds
 Crowfoot, 1-1/2 Inch
 Crowfoot, 1-5/8 Inch

Materials:

Lockwire (E231)

Parts:

Packings

Personnel Required:

Medium Helicopter Repairer
 Inspector

References:

TM 55-1520-240-23P

General Safety Instructions:

WARNING

All regulations and instructions for handling fuels shall be strictly observed.

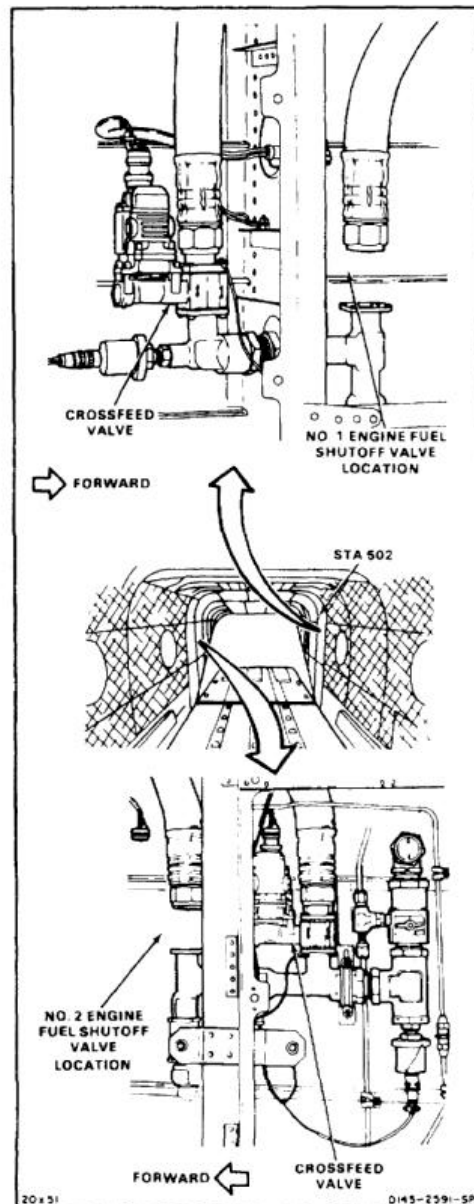

NOTE

There are two engine fuel shutoff valves. Procedure is same to install either valve. No. 2 (right side) valve is shown here.

1. Remove plug from tee (1).
2. Position packing (2) and valve (3) on tee (1). Install four bolts (4) and washers (5). Lockwire four bolts. Use lockwire (E231).
3. Position packing (6) and adapter (7) on valve (3). Install electrical load (8), four washers (9) and bolts (10). Lockwire four bolts. Use lockwire (E231).
4. Install electrical lead (11), bolt (12) and nut (13) on flange of tee (1).
5. Remove plug from hose connector (14). Install packing (15) in hose connector.
6. Connect hose connector (14) to adapter (7). Torque hose connect or to **1125 inch-pounds**.
7. Install clip (16), electrical load (17), two washers (18), screw (19) and nut (20) on hose connector (14).
8. Connect electrical connector (21).

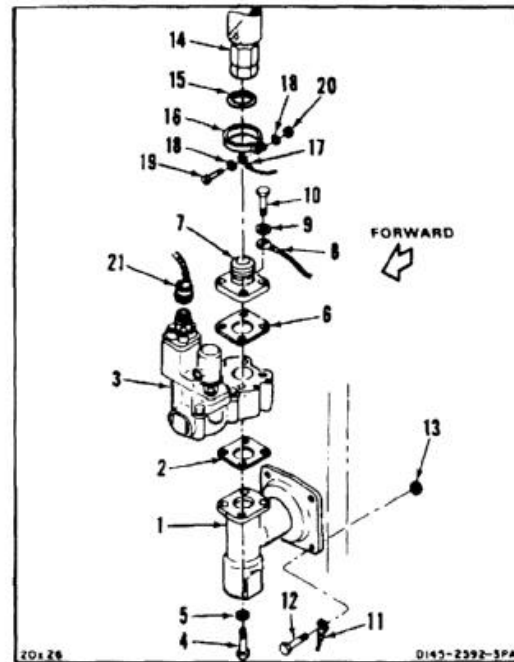
**INSPECT****FOLLOW-ON MAINTENANCE:**

- Perform operational check of fuel system (TM 55-1520-240-T).
- Bleed fuel system (Task 10-121).

END OF TASK

INITIAL SETUP

Applicable Configurations:

All

Tools:

- Aircraft Mechanic's Tool Kit, NSN 5180-00-323-4692
- Wrench, Open End, 1-5/8 Inch
- Wrench, Open End, 1-1/2 Inch
- Grounded Container, 2 Quart or Equivalent

Materials:

Cloths (E135)

Personnel Required:

Medium Helicopter Repairer

Equipment Condition:

- Battery Disconnected (Task 1-39)
- Electrical Power Off
- Helicopter Grounded (Task 1-29)

General Safety Instructions:

WARNING

All regulations and instructions for handling fuels shall be strictly observed.

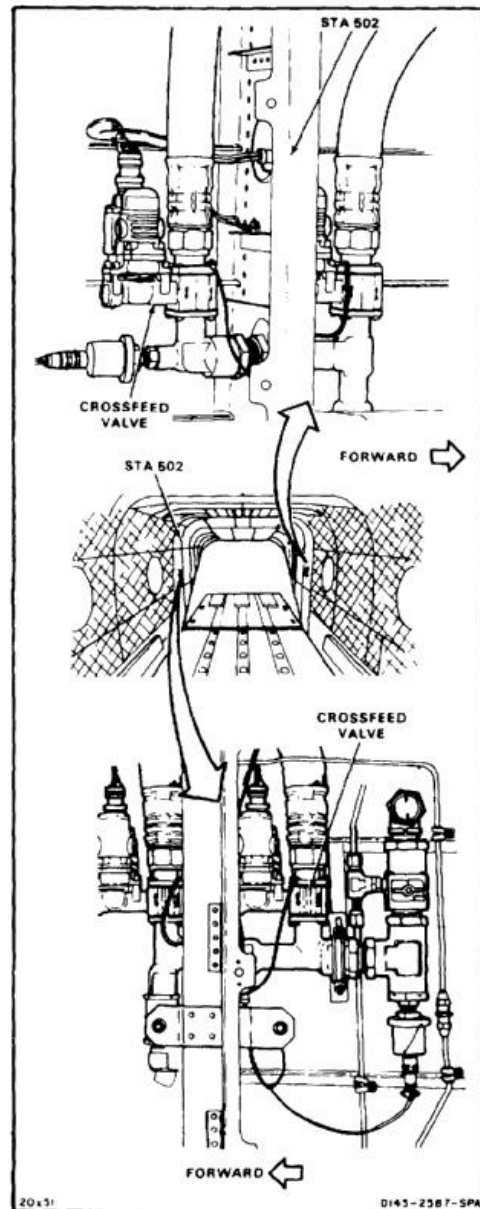

NOTE

There are two fuel crossfeed valves. Procedure is same to remove either valve. No. 2 (right side) valve is shown here.

1. Make sure manual override crossfeed valve (1) is CLOSED.
2. Disconnect electrical connector (2) from valve (3).
3. Remove nut (4), screw (5), two washers (6), electrical lead (7), and clip (8).
4. Disconnect hose (9) from adapter (10). Remove packing (11). Use container for any spilled fuel. Plug hose.
5. Remove electrical lead (12), bolt (13), nut (14) and two washers (15) from adapter (16).
6. Remove lockwire, four bolts (17) and washers (18).
7. Remove valve (3) and packing (19) from tee (20). Plug hole in tee. Clean up any spilled fuel. Use cloths (E135).

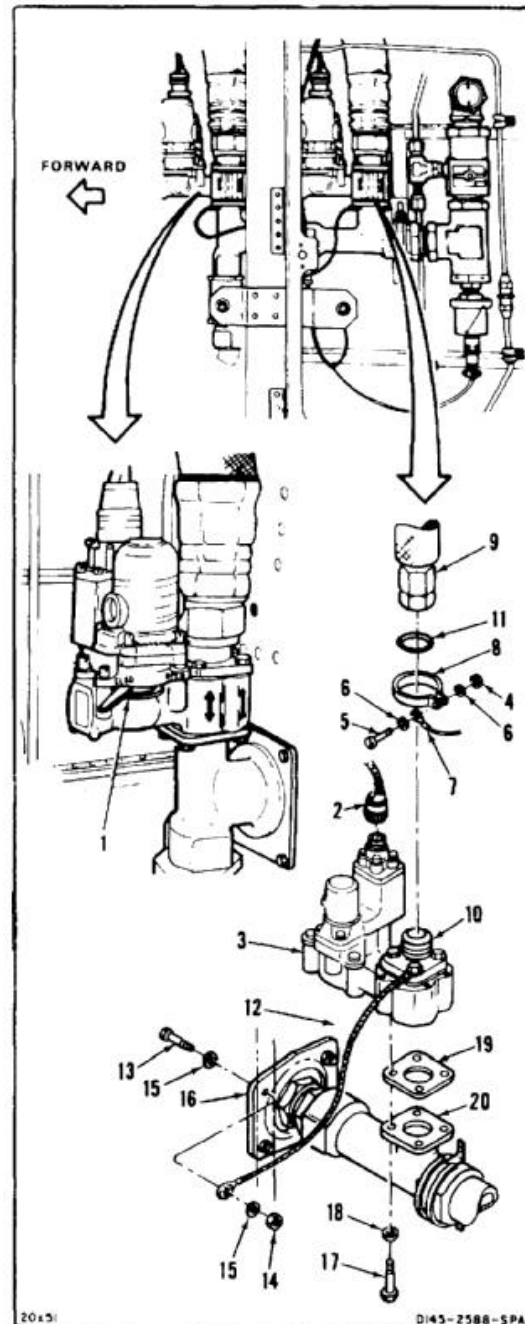

8. Remove lockwire, four bolts (21), four washers (22) and electrical lead (12) from valve (3).
9. Remove adapter (10) and packing (24) from valve (3).
10. Clean up spilled fuel. Use cloths (E135).

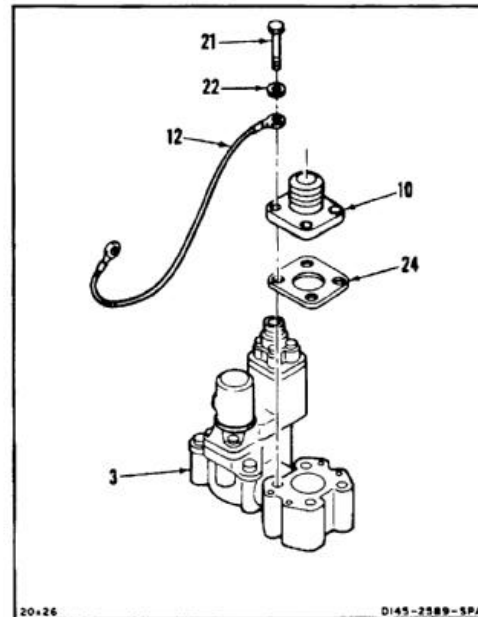
***FOLLOW-ON MAINTENANCE:***

None

END OF TASK

10-488

INITIAL SETUP

Applicable Configurations:

All

Tools:

Aircraft Mechanic's Tool Kit, NSN 5180-00-323-4692
 Torque Wrench, 700-1600 Inch-Pounds
 Crowfoot Attachment, 1-1/2 Inch

Materials:

Lockwire (E231)

Parts:

Packings

Personnel Required:

Medium Helicopter Repairer
 Inspector

References:

TM 55-1520-240-23P

General Safety Instructions:**WARNING**

All regulations and instructions for handling fuels shall be strictly observed.

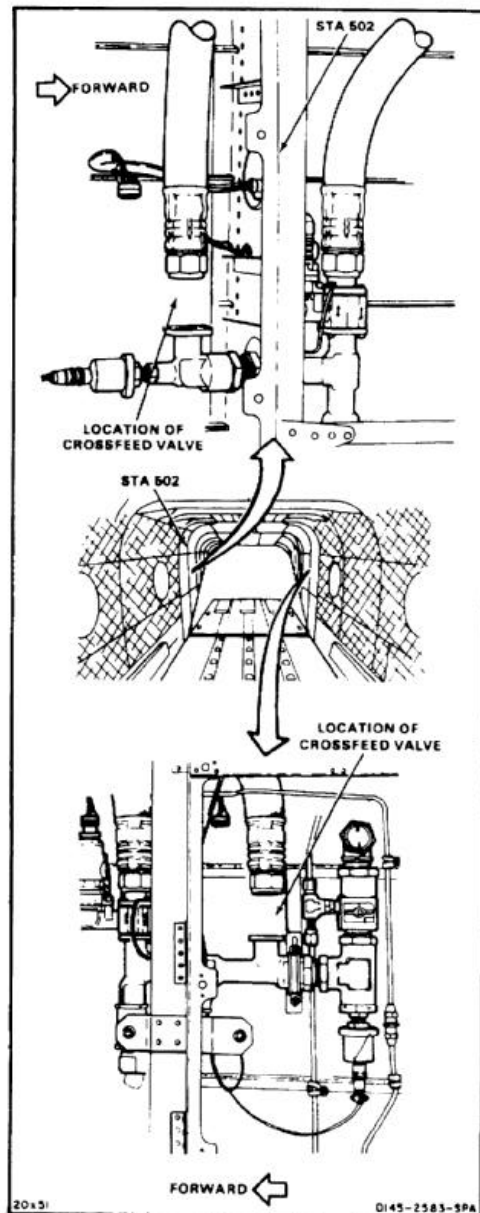

NOTE

There are two fuel crossfeed valves. Procedure is same to install either valve. No. 2 (right side) valve is shown here.

1. Position packing (1) and adapter (2) on valve (3).
2. Install electrical lead (4), four bolts (5) and washers (6). Lockwire bolts. Use lockwire (E231).

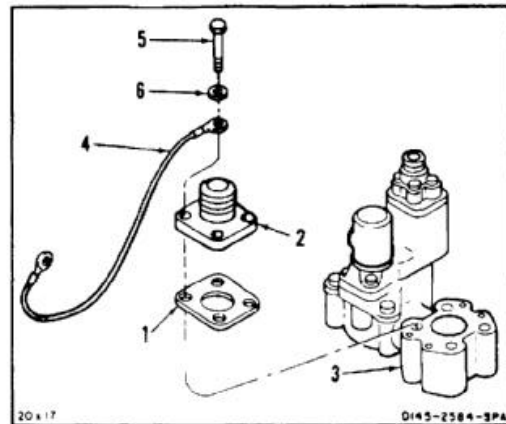

3. Remove plug from tee (7).
4. Position packing (8) and valve (3) on tee (7). Install four washers (9) and bolts (10). Lockwire bolts (10). Use lockwire (E231).
5. Install electrical lead (4) on adapter (11) with two washers (12), bolt (13), and nut (14).
6. Remove plug from hose connector (15). Install packing (16) in hose connector.
7. Connect hose connector (15) to adapter (2). Torque hose connector to **1125 inch-pounds**.
8. Install clip (17), electrical lead (18), two washers (19), screw (20) and nut (21).
9. Connect electrical connector (22).

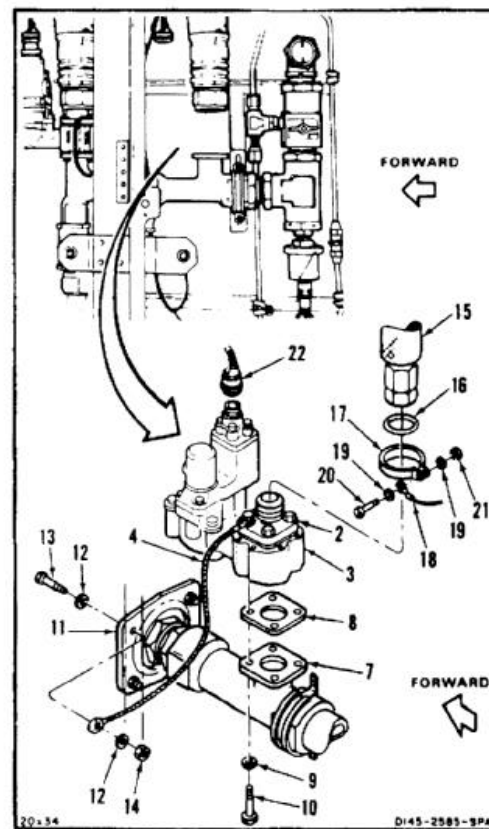
**INSPECT****FOLLOW-ON MAINTENANCE:**

- Bleed fuel system (Task 10-121).
- Perform operational check of fuel system (TM 55-1520-240-T).
- Check for leaks (Task 10-4).

END OF TASK

10-490

10-115 REMOVE FUEL PUMP RELAY

10-115

INITIAL SETUP**Applicable Configurations:**

All

Tools:

Aircraft Mechanic's Tool Kit, NSN 51 80-00-323-4692

Materials:Paper Tags (E264)
Tape (E385)**Personnel Required:**

Medium Helicopter Repairer

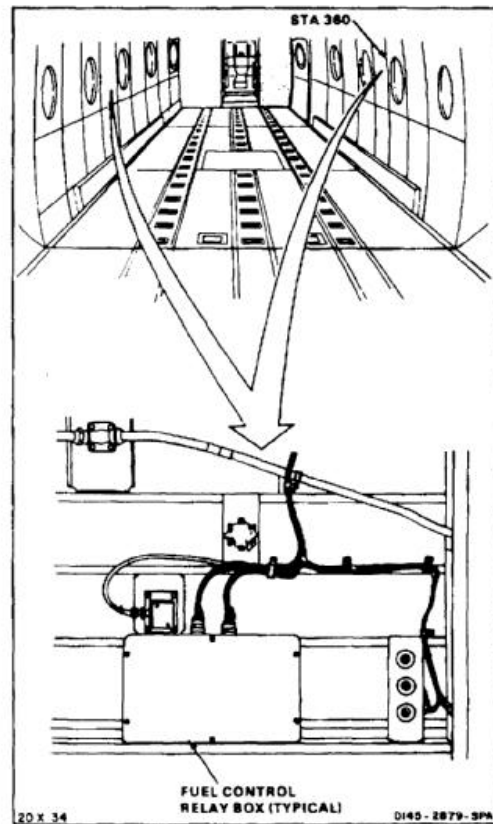
Equipment Condition:Battery Disconnected (Task 1-39)
Electrical Power Off
Side Acoustical Blanket Removed Between Sta. 320
and 360 (Task 2-208)**NOTE**

There are four fuel pump relays on each side. Procedure is same to remove any relay. Aft right side relay is shown here.

1. Remove six screws (1) from cover (2). Remove cover.

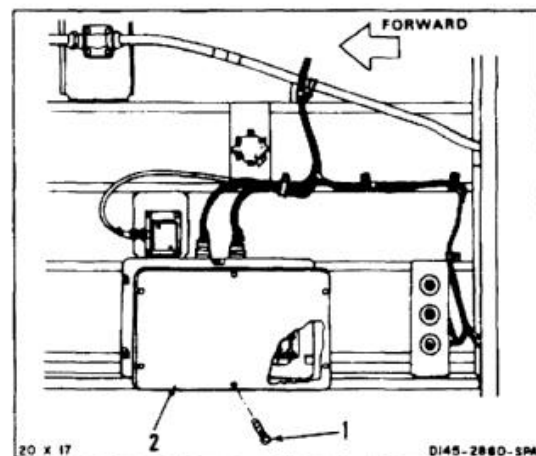

2. Tag eight wires (3). Remove eight screws (4) and washers (5). Disconnect eight wires (3) from relay (6). Tape wire ends. Use tape (E385).
3. Remove four screws (7) and washers (8). Remove relay (6).

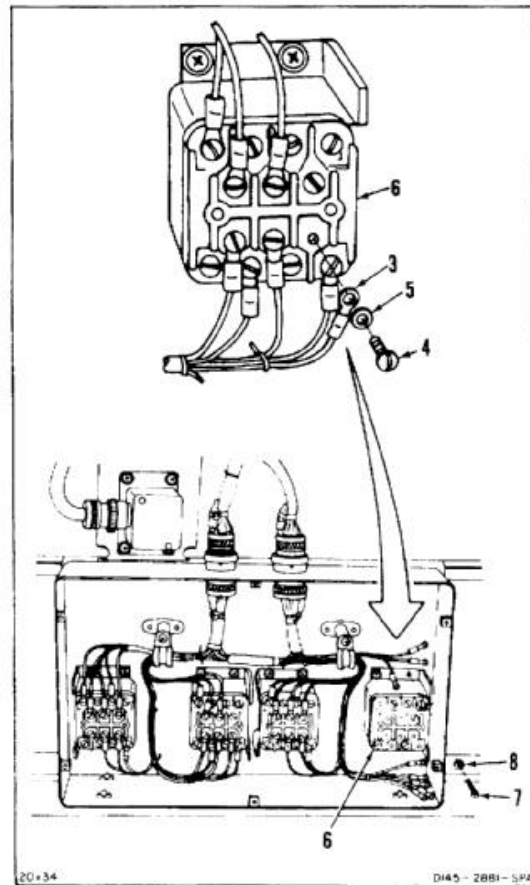
**FOLLOW-ON MAINTENANCE:**

None

END OF TASK

10-492

INITIAL SETUP

Applicable Configurations:

All

Tools:

Aircraft Mechanic's Tool Kit, NSN 51 80-00-323-4692

Materials:

None

Personnel Required:Medium Helicopter Repairer
Inspector**References:**

TM 55-1520-240-23P

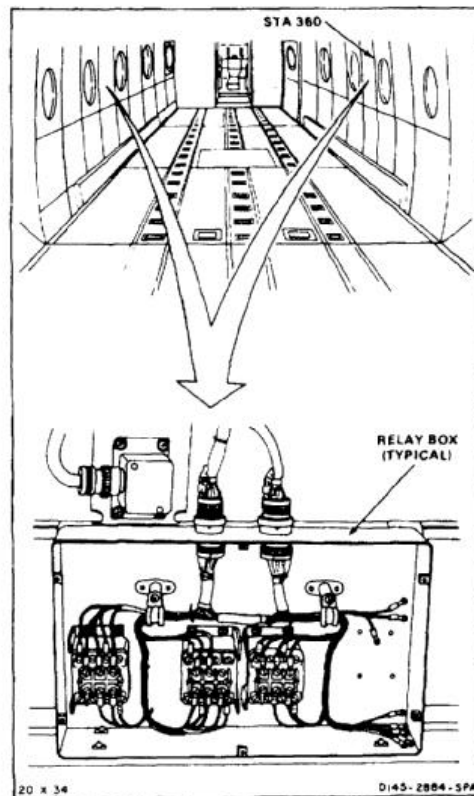
**NOTE**

There are four fuel pump relays on each side. Procedure is same to install any relay. Aft right side relay is shown here.

1. Position fuel pump relay (1). Install four screws (2) and washers (3).

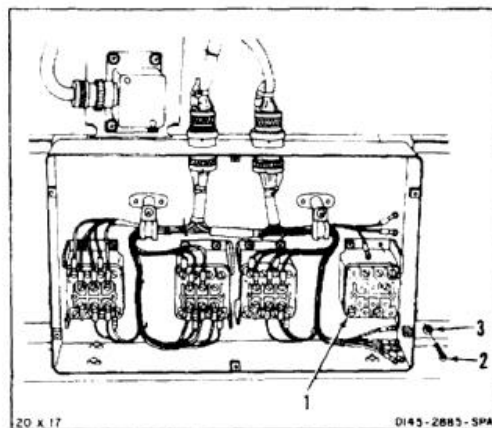

2. Remove tape and connect eight wires (4) to relay (1) as tagged. Install eight washers (5) and screws (6). Remove tags.

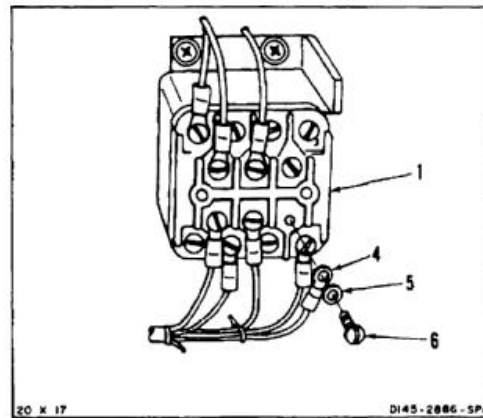
INSPECT

3. Install cover (7) and six screws (8).

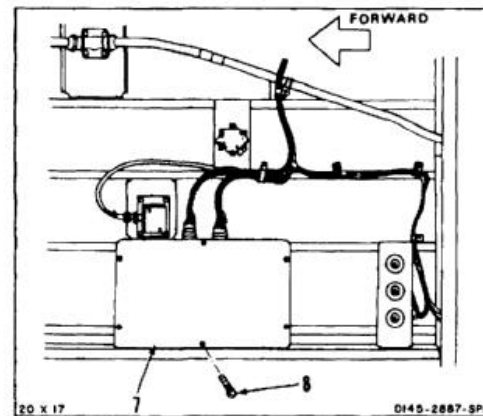
**INSPECT****FOLLOW-ON MAINTENANCE:**

- Perform operational check of related fuel boost pump(s) (TM 55-1520-240-T).
- Install side acoustical blanket between sta. 320 and 360 (Task 2-210).

END OF TASK

10-494

10-116.1 REMOVE FUEL PUMP RELAY BOX

10-116.1

INITIAL SETUP**Applicable Configurations:**

All

Tools:

Aircraft Mechanic's Tool Kit, NSN 51 80-00-323-4692

Materials:

None

Personnel Required:

Medium Helicopter Repairer

Equipment Condition:

Battery Disconnected (Task 1-39)

Electrical Power Off

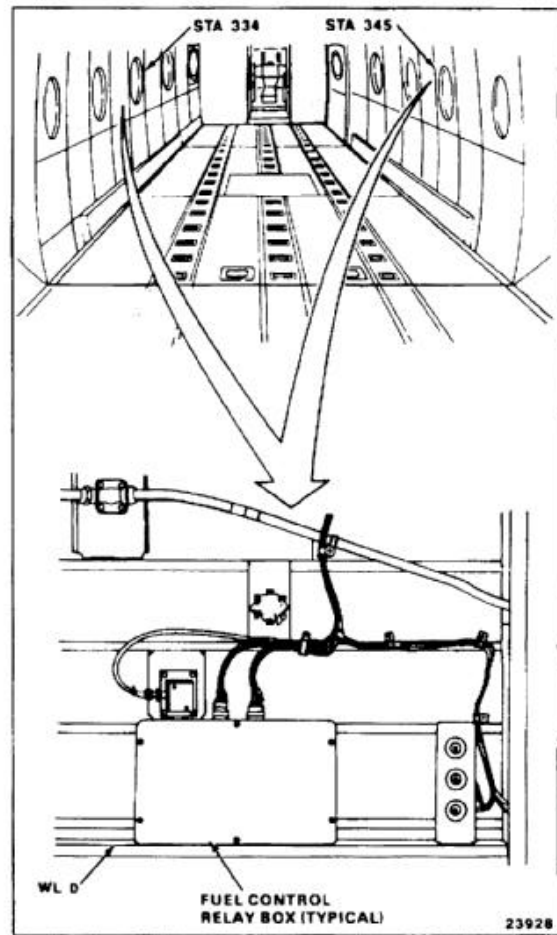
Side Acoustical Blanket Removed Between Sta. 320
and 360 (Task 2-208)**NOTE**

There is a fuel pump relay box on each side of cabin. Procedure is same to remove either box. Right relay box is shown here.

1. Disconnect two connectors (1) from relay box (2).
2. Remove six screws (3) from cover (4). Remove cover.

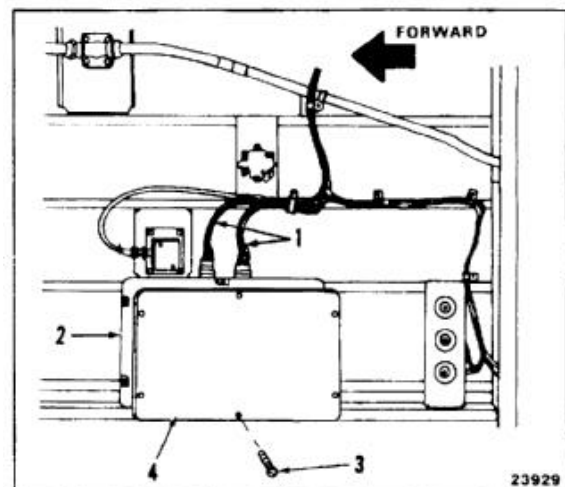

3. Remove four screws (5) and washers (6) from under structure (7).
4. Remove two screws (8) and washers (9) from back of box (2).

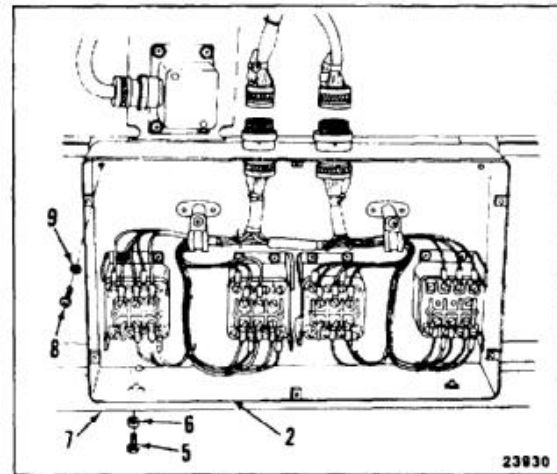
**NOTE**

Certain helicopters have four spacers installed between bottom of box and structure.

5. Remove box (2) and spacers (10) as necessary.

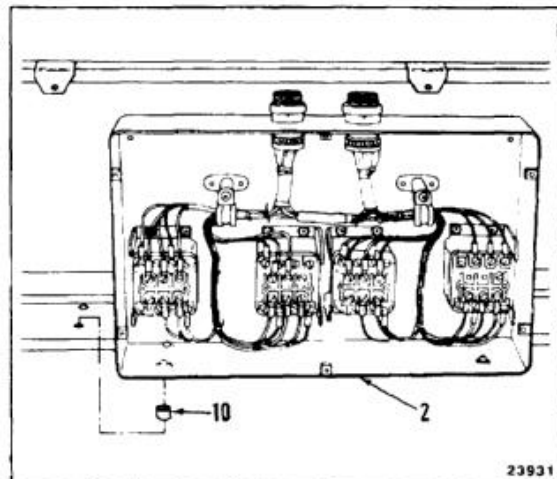
**FOLLOW-ON MAINTENANCE:**

None

END OF TASK

10-496

10-116.2 INSTALL FUEL PUMP RELAY BOX**10-116.2****INITIAL SETUP****Applicable Configurations:**

All

Tools:

Aircraft Mechanic's Tool Kit, NSN 51 80-00-323-4692

Materials:

None

Personnel Required:Medium Helicopter Repairer
Inspector**References:**

TM 55-1520-240-23P

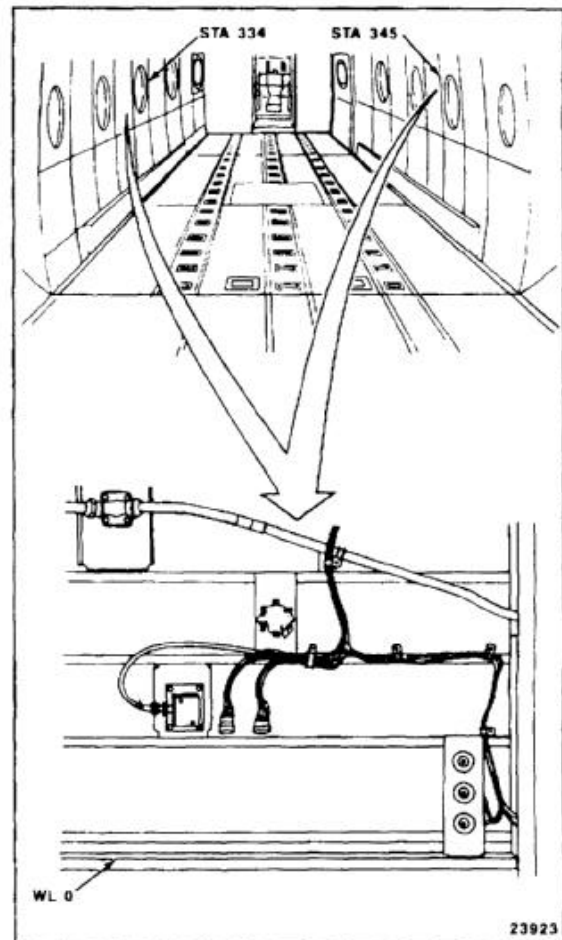
**NOTE**

There is a fuel pump relay box on each side of cabin. Procedure is same to install either box. Right relay box is shown here.

1. If a new box (1) is being installed, remove six screws (2). Remove cover (3).

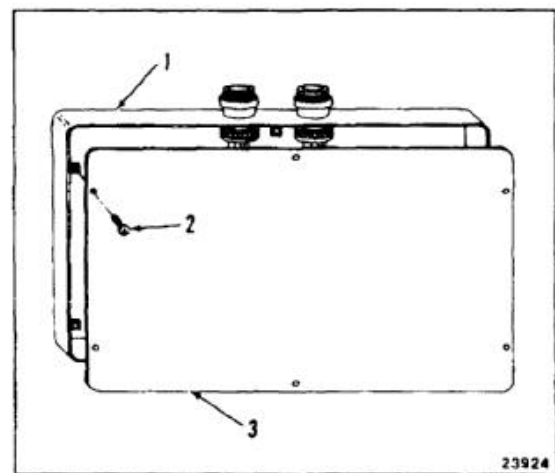

NOTE

Certain helicopters have four spacers installed between bottom of box and structure,

2. Position box (1) and four spacers (4), if required, on structure (5).

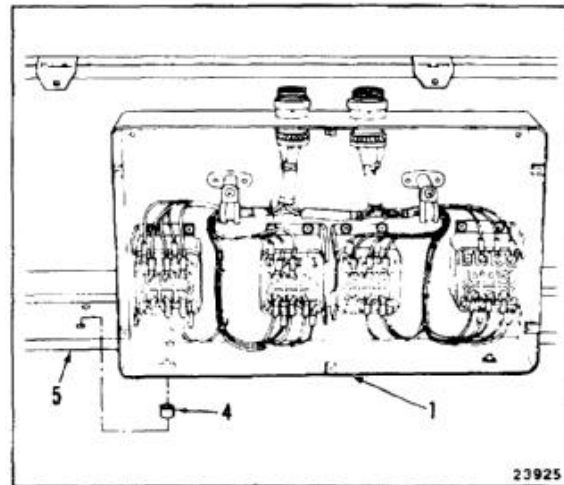

3. Install four screws (6) and washers (7) under box (1).
4. Install two screws (8) and washers (9) in back of box (1).

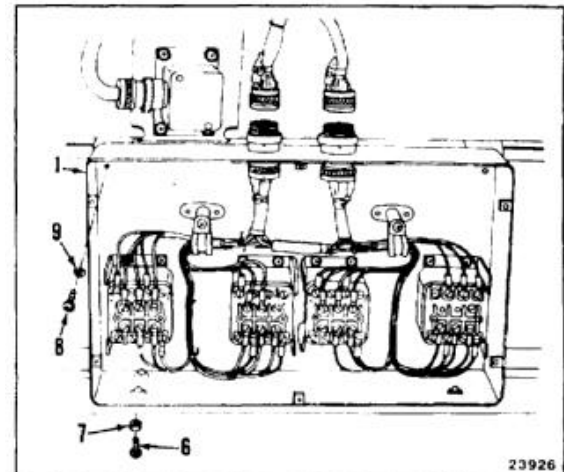

5. Connect two connectors (10).
6. Position cover (3) on box (1) and install six screws (2).

INSPECT

FOLLOW-ON MAINTENANCE:

Perform operational check of related fuel boost pump(s) (TM 55-1520-240-T).
 Install side acoustical blanket between sta. 320 and 360 (Task 2-210).

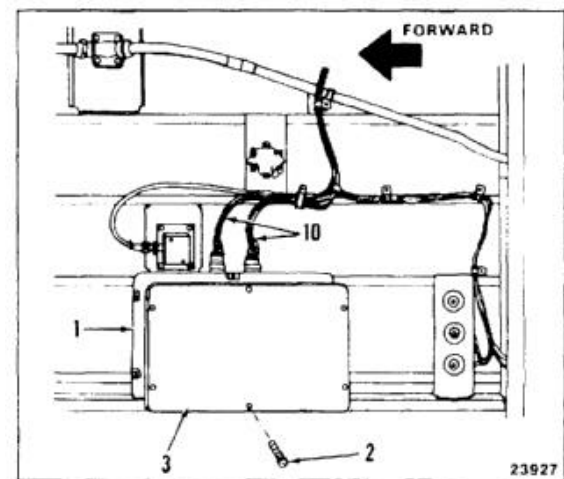

END OF TASK

INITIAL SETUP

Applicable Configurations:

All

Tools:

Aircraft Mechanic's Tool Kit, NSN 51 80-00-323-4692
 Stopwatch
 Valve, Shutoff
 Valve, Vent
 Torque Wrench, 700 to 1600 Inch-Pounds
 Gage, 60 psi
 Nitrogen Supply With Regulator
 Test Plug (E55)

Materials:

Soap (E353)
 Brush (E85)
 Conical Flared Seals VSF1015A16B

Personnel Required:

Medium Helicopter Repairer
 Inspector

References:

TM 55-1520-240-23P

Equipment Condition:

Battery Disconnected (Task 1-39)
 Electrical Power Off
 Helicopter Grounded (Task 1-29)
 Affected Side of Helicopter Defueled (Task 10-34 or 10-35)
 Tank Forward Access Door Removed (Task 10-51 for Main Tank or 10-79 for Aft Tank)
 Forward Tank Aft Access Door Removed (Task 10-24)

General Safety Instructions:**WARNING**

All regulations and instructions for handling fuels shall be strictly observed.

CAUTION

Do not allow elbows or nipples to turn when disconnecting fuel hoses from aft access panel. Otherwise, access panel fittings can fail and cause blockage.

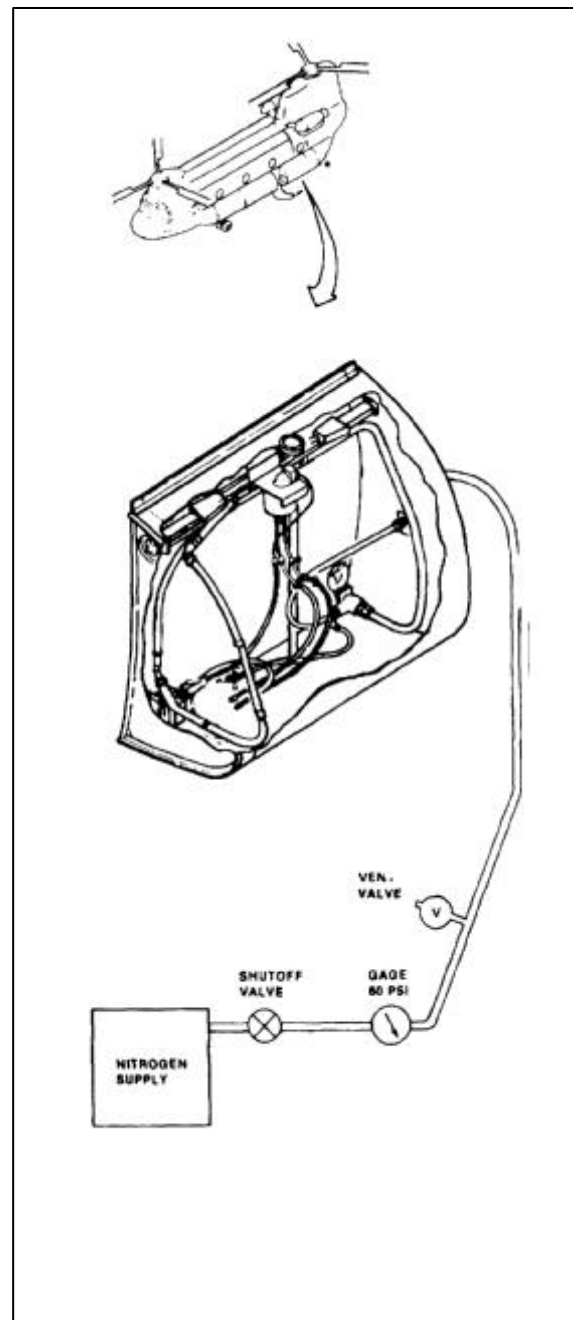

CAUTION

Do not puncture or scratch lining of fuel tank. If lining is broken, fuel penetrates and activates self-sealing layers. Activated layers swell and trap fuel. Activated green spongy material also contaminates fuel system. This makes it necessary to replace fuel tank and flush fuel system.

NOTE

Procedure is similar to pressure test vent system in any tank. Differences are noted in text.

1. Hold fitting (1) with wrench and disconnect hose (2). Install plug in hose.
2. Remove drain valve (3) with packings (4 and 5). Install packing (4) on plug (5.1) and install into port (6).

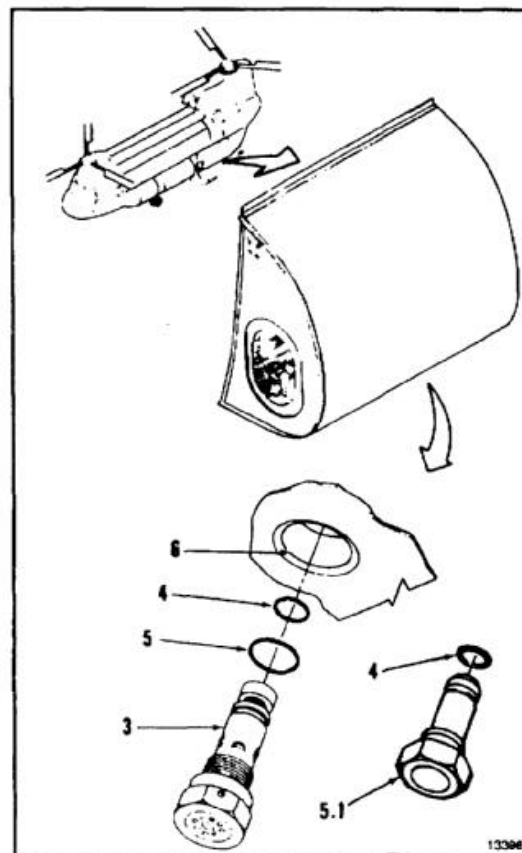
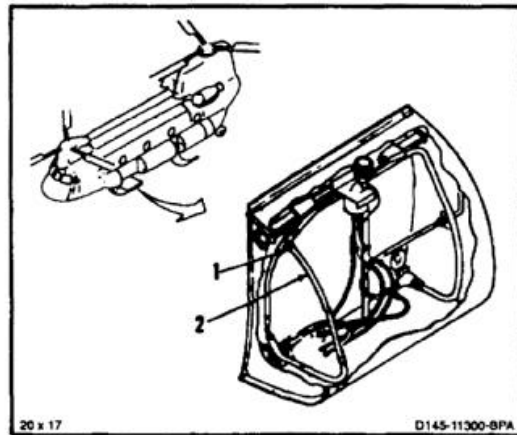

3. On main or aft tank (7) only, hold elbow (8) with wrench and disconnect hose (9). Install plug in hose.

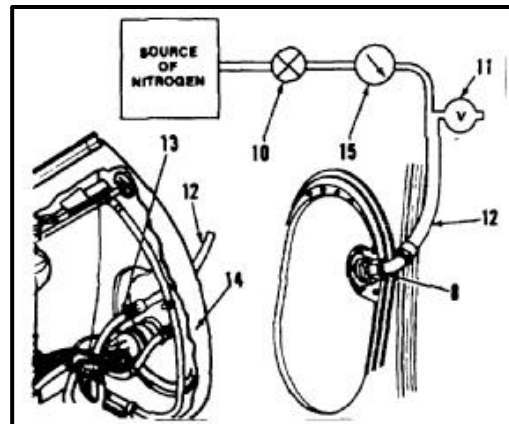

4. Make sure shutoff valve (10) and vent valve (11) are closed. Connect hose (12) from test setup to elbow (8) on main or aft tank (7), or hose (13) in forward tank (14).
5. Slowly open shutoff valve (10) until gage (15) indicates **20 psi**. Close valve.
6. Wait **5 minutes** and check gage (15). If gage indicates **20 psi**, go to step 8. If gage indicates less than **20 psi**, go to step 7.

CHECK FOR LEAKS

7. Check for leaks as follows:
- Check test setup upstream and downstream of valves (10 and 11), and gage (15). Use mixture of soap (E353) and water, and brush (E85). Allow system to remain under pressure for **15 minutes**. If bubbles grow in size, connection is leaking. Tighten leaking connections or replace packings as needed. Also check all joints, seams, and cast components. Repeat steps 5 and 6.

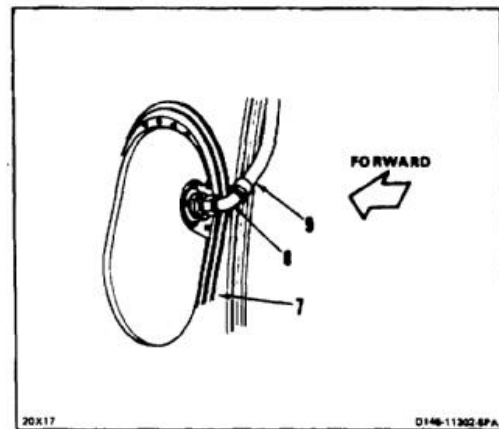

- b. Check vent system (16) inside tank (7 or 14). Apply soap mixture, as in step 7a, to all connections. Secure any loose connections.
 - c. If connections are still leaking, use conical seals as required.
8. Open relief valve (11) to reduce pressure to **0 psi**.

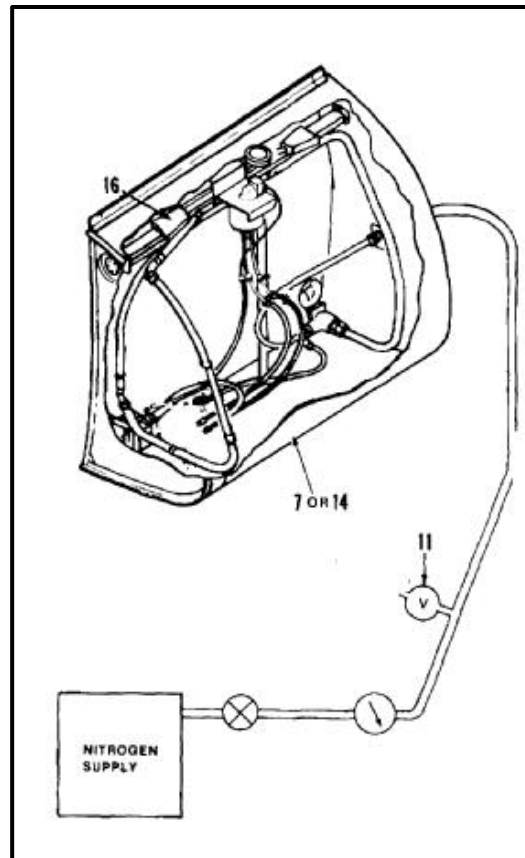

9. On main or aft tank (7) only, hold elbow (8) with wrench and disconnect test hose (12). Remove plug and connect hose (9) to elbow.
10. On forward tank (14) only, disconnect test hose (12) from hose (13).

INSPECT

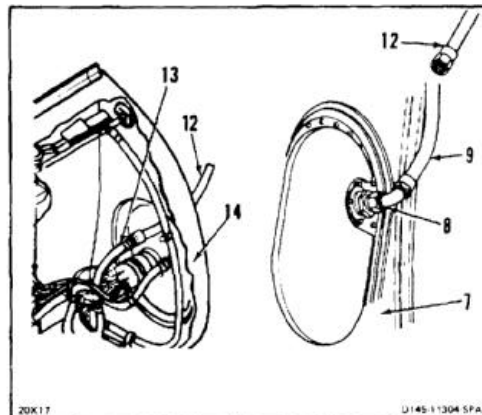

11. Remove plug (E55) (5.1) from port (6). Install packings (4 and 5) on drain valve (3). Install drain valve in port.

INSPECT

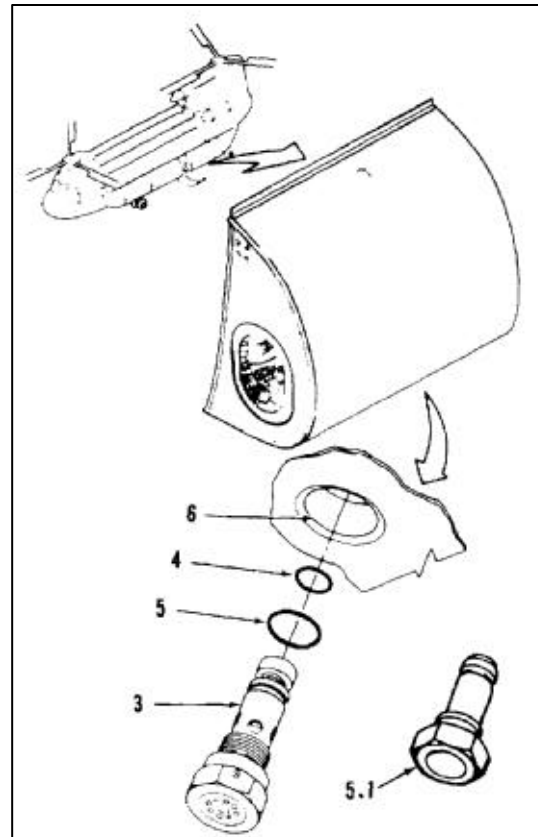

12. Remove plug from hose (2). Connect hose to fitting (1). Torque connection to **1150 inch-pounds**.

FOLLOW-ON MAINTENANCE:

Install forward access door on main or aft tank (Task 10-52 or 10-80).

Install aft access door on forward tank (Task 10-25).

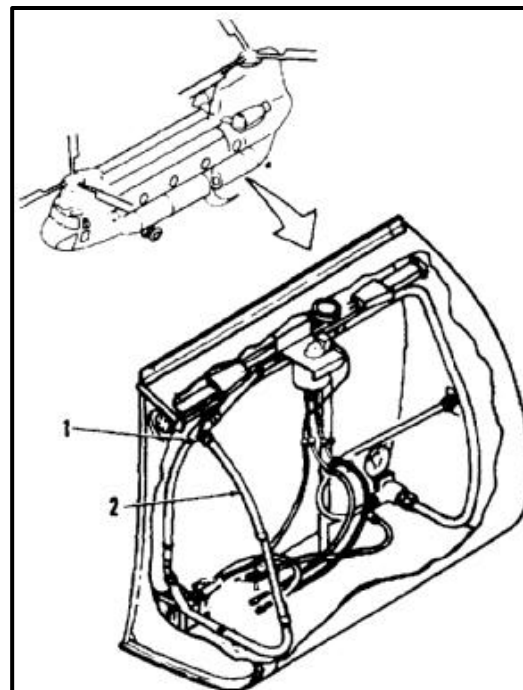

END OF TASK

INITIAL SETUP

Applicable Configurations:

All

Tools:

- Aircraft Mechanic's Tool Kit, NSN 5180-00-323-4692
- Test Equipment (2TE414P0200-8)
- Source of Compressed Air, 100 psi
- Hoses (2), 3/4 Inch
- Stopwatch

Materials:

None

Personnel Required:

- Medium Helicopter Repairer
- Inspector

References:

- Task 10-24
- Task 10-25
- Task 10-51
- Task 10-52
- Task 10-79
- Task 10-80

Equipment Condition:

- Battery Disconnected (Task 1-39)
- Electrical Power Off
- Affected Side of Helicopter Defueled (Task 10-34 or 10-35)

General Safety Instructions:

WARNING

All regulations and instructions for handling fuels shall be strictly observed.

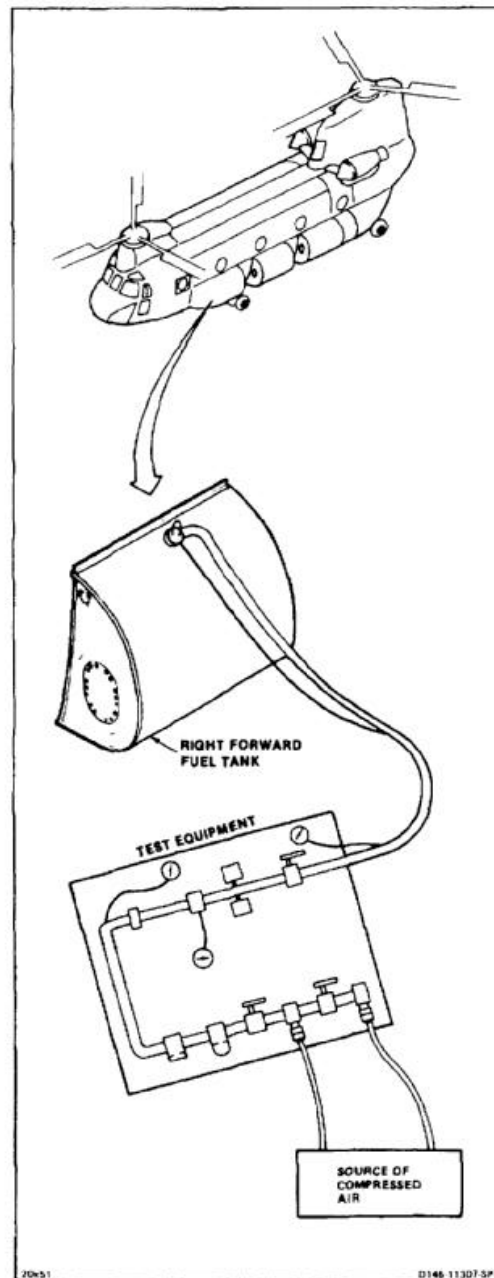

NOTE

Procedure is same to test any fuel tank. Test of No. 1 (left) forward fuel tank is shown.

1. Straighten hoses (1 and 2) to plug (3).
2. Close valves (4 and 5).
3. Open valve (6).
4. Connect two hoses (7 and 8) to fittings (9 and 10).
5. Open valves (4 and 5).
6. Check gage (11). Gage shall read **24 to 30 psi**.
7. Check gage (12). Gage shall read **1 to 3 psi**.
8. Slowly close valve (6). Check gage (12). Two valves (13 and 14) shall open when gage indicates **5 psi**.
9. Gage (12) shall indicate **6 psi** with valve (6) closed. Two valves (13 and 14) shall be venting equally.

WARNING

Do not continue test if pressure exceeds **6 psi**. Damage to personnel and equipment could occur.

10. Open valve (6).
11. Close valves (4 and 5).
12. Check gage (15). Gage shall read **0 psi**.
13. Remove cap (16) from fuel tank (17).

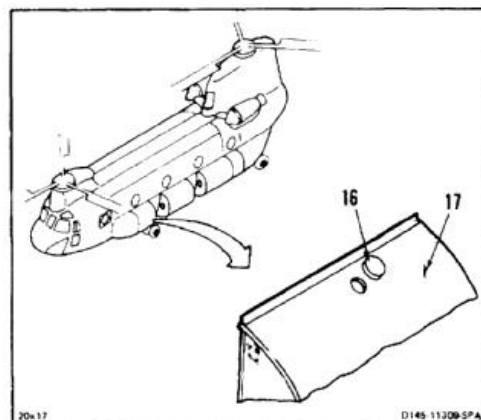
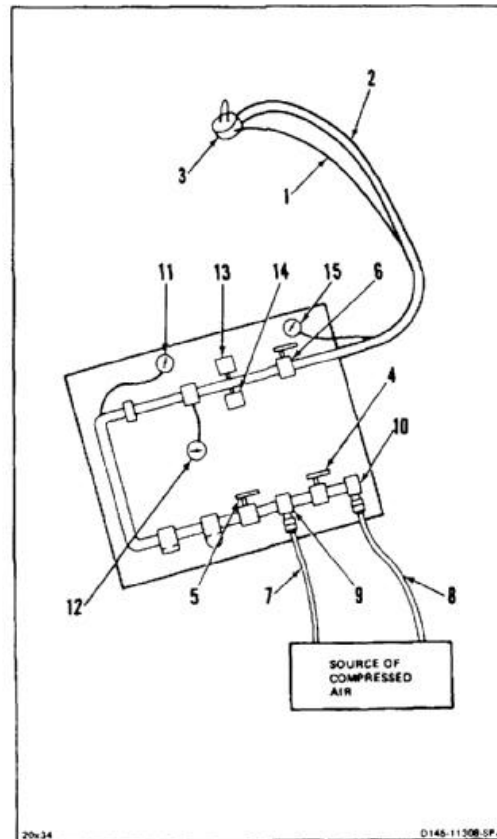

14. Install plug (3) in gravity fill port of fuel tank (17).
15. Open valve (4).



Test equipment must be watched closely to prevent damage to aircraft if vent system is blocked. Vent system blockage will cause pressure to rise quickly and damage will occur.

16. Slowly open valve (5) while watching gage (12). If gage reads above **3 psi** close valve and go to step 17. If gage does not read above **3 psi**, go to step 19.

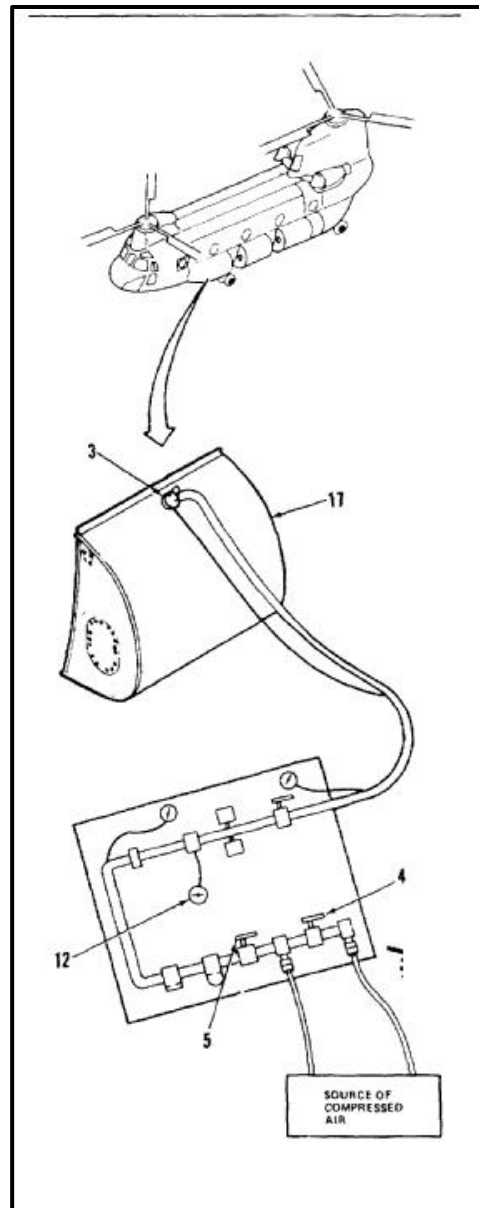

17. Check for blockage as follows:
 - a. Check vent breakaway fitting (18) at aft end of tank (17). Replace fitting, if needed. Repeat step 16.
 - b. At main or aft tank only, remove tank forward access door (Task 10-51 or 10-79). At forward tank only, remove aft access door (Task 10-24).
 - c. Check vent system hoses (18) and tubes (19) for kinks. Replace kinked tube or hose.
 - d. If hoses (18) or tubes (19) are not kinked, remove each hose or tube until blockage source is located. Install hoses or tubes removed for blockage check.
 - e. At main or aft tank only, install forward access door (Task 10-52 or 10-80). At forward tank only, install aft access door (Task 10-25).
18. Repeat step 16.
19. With valve (5) open, wait **1 minute**. Check gage (15). For forward (17) or aft (20) tanks only, if gage reads between **1.25 and 2.25 psi** go to step 20. For main tank (21) only, if gage reads between **1.5 and 2.5 psi**, go to step 20. If gage reading is not within these limits, repeat step 17.
20. Slowly close valves (4 and 5).
21. Close valve (6).
22. Check gage (15). When gage reads **0 psi** remove plug (3).
23. Disconnect two hoses (7 and 8) from two fittings (9 and 10).

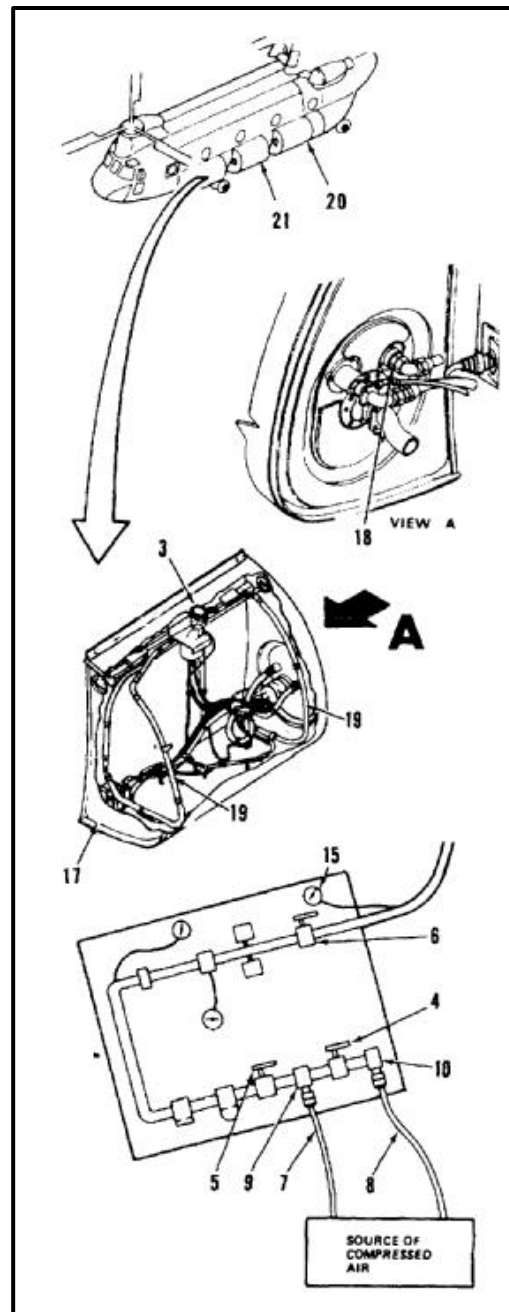

24. Install cap (16) in fuel tank (17).

FOLLOW-ON MAINTENANCE:

Refuel helicopter (Task 1-51).

Bleed fuel system (Task 10-121).

Perform operational check of affected fuel system
(TM 55-1520-240-T).

Inspect for leaks (Task 10-22 main tank, Task 10-27
forward tank, Task 10-32 aft tank).

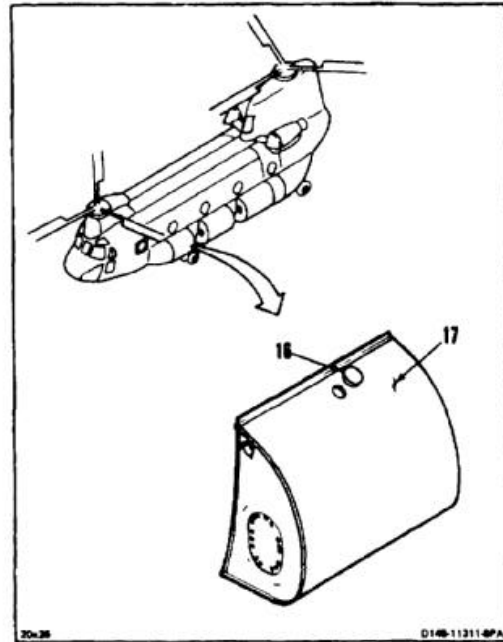

END OF TASK

10-508

INITIAL SETUP

Applicable Configurations:

All

Tools:

Aircraft Mechanic's Tool Kit, NSN 5180-00-323-4692
 Nitrogen Supply With Regulator
 Shutoff Valve
 Vent Valve
 Gage, 120 psi with 5 psi Graduations
 Stopwatch
 Closure Plates, 3 each (APP E-17)
 Grounded Container, 2 Quart or Equivalent

Materials:

Cloths (E135)
 Soap (E353)
 Brush (E85)

Parts:

Plug, AN806-8D
 Gaskets, BACG10AD (4)

Personnel Required:

Medium Helicopter Repairer
 Inspector

References:

Appendix E
 TM 55-1520-240-T
 TM 1-1500-204-23

Equipment Condition:

Battery Disconnected (Task 1-39)
 Electrical Power Off
 Forward Landing Gear Access Panel Open (Task 2-2)
 Helicopter Defueled (Task 10-34 or 10-35)
 Aft Intertank Pod Panel Opened (Task 2-2)
 Test Setup

General Safety Instructions:**WARNING**

All regulations and instructions for handling fuels shall be strictly observed.

CAUTION

Do not allow elbows or nipples to turn when disconnecting fuel hoses from access panel. Otherwise, access door fittings can fall and cause blockage.

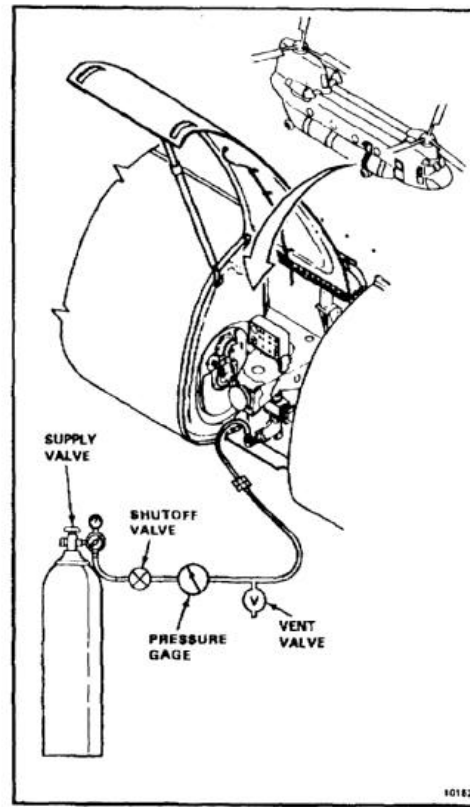

1. Make sure two valves (1) are CLOSED. If valves are not closed, refer to TM 55-1520-240-T.

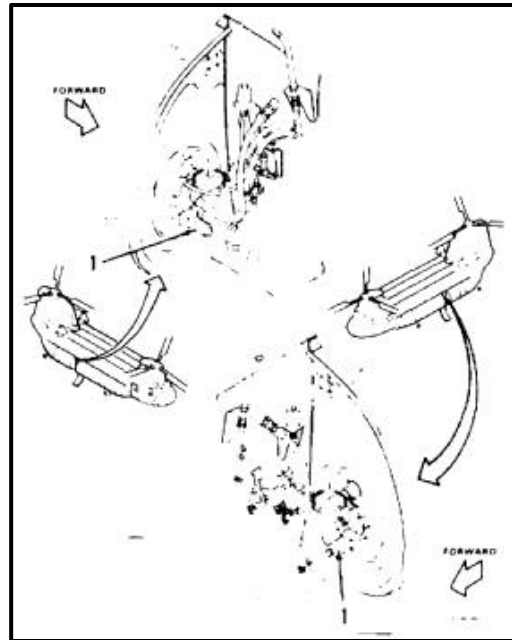

2. Hold fitting (2) with wrench and disconnect hose (3). Plug hose. Use grounded container for spilled fluid. Clean up spilled fluid with cloths (E135).

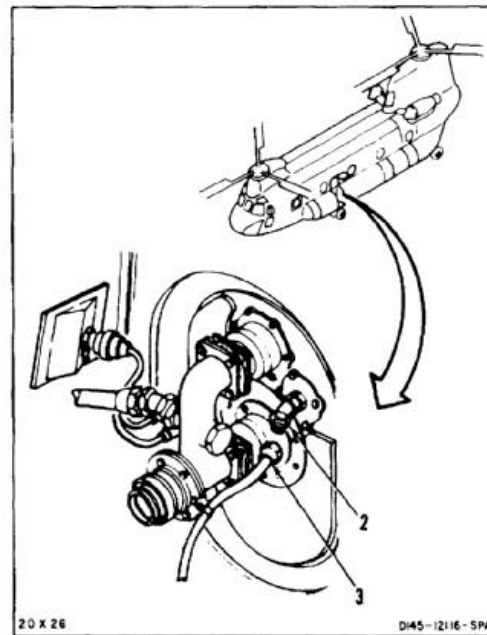

3. Remove four nuts (4), washers (5), and bolts (6).
4. Slide tube (7) and gasket (8) aft.

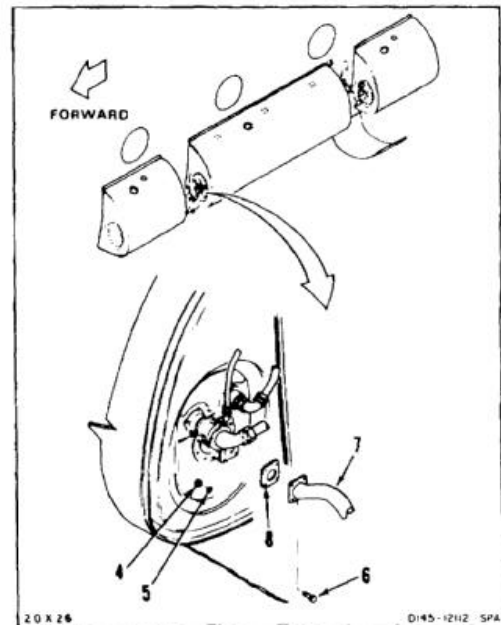

5. Install gasket (9) and plate (10) (APP E-17).
6. Slide tube (7) and gasket (8) forward and install four bolts (6), nuts (4), and washers (5).
7. Repeat steps 2 thru 6, at No. 2 forward fuel tank.

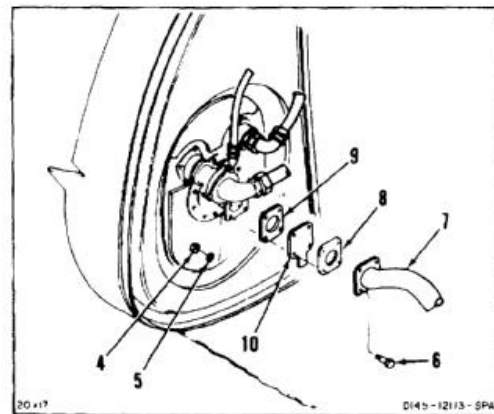

8. Remove eight nuts (11), washers (12), and bolts (13). Slide manifold (14) and gaskets (15 and 16) forward. Use container for spilled fluid. Clean up spilled fluid with cloths (E135).

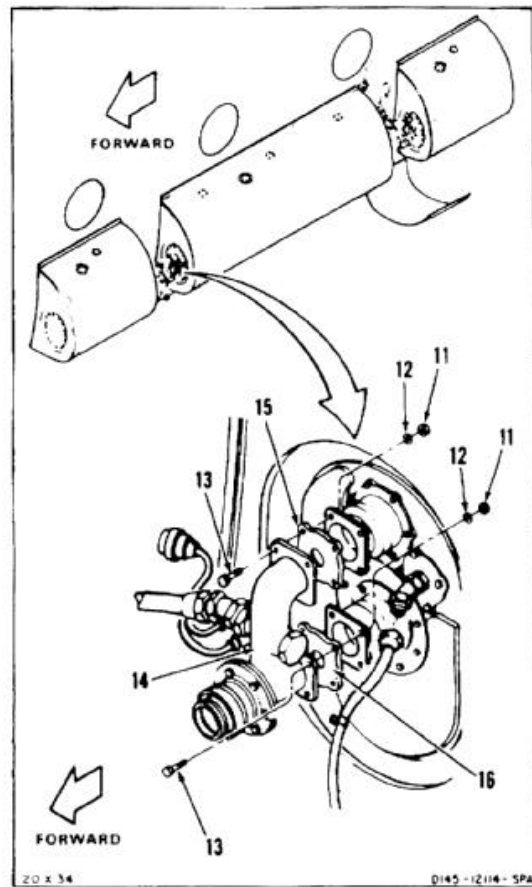

CAUTION

Gaskets and plates must be installed in correct order. Otherwise damage to fittings will result.

9. Install gasket (17) and plate (E-17) (18) on lower filling (19).
10. Install gasket (20) and plate (E-17) (21) with hole on upper fitting (22).
11. Slide manifold (14) and gaskets (15 and 16) aft.
12. Install eight bolts (13), nuts (11), and washers (12).
13. Repeat steps 8 thru 12 at No. 2 main fuel tank.

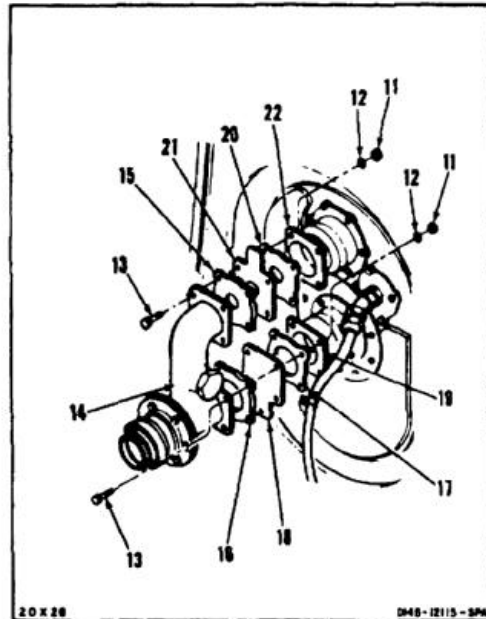

14. Make sure shutoff valve (23) is closed and vent valve (24) is closed. Hold fitting (25) with wrench and disconnect hose (26). Connect test setup to hose.
15. Open supply valve (23.1) and regulate pressure to **120 psi**. Open valve (23) and allow pressure to stabilize at **120 psi** on gage (27). Close valve (23).
16. Wait **5 minutes**. Check that gage (27) indicates 120 psi. If gage reads **120 psi**, go to step 19. If gage reads less than **120 psi**, go to step 17.
17. Check for leaks as follows:
 - a. If any leak is found in steps 17b thru 17h replace packings or parts and repeat steps 15 and 16.
 - b. Check test setup connections upstream and downstream of valves (23 and 24), and gage (27). Use mixture of soap (E353) and water, and brush (E85). Allow system to remain under pressure for **15 minutes**. If bubbles grow in size, connection is leaking. Tighten leaking connections or replace packings as needed. Also check all joints, seams, and cast components.
 - c. Check at filler adapter (28). Use soap and water mixture as in step 17b.

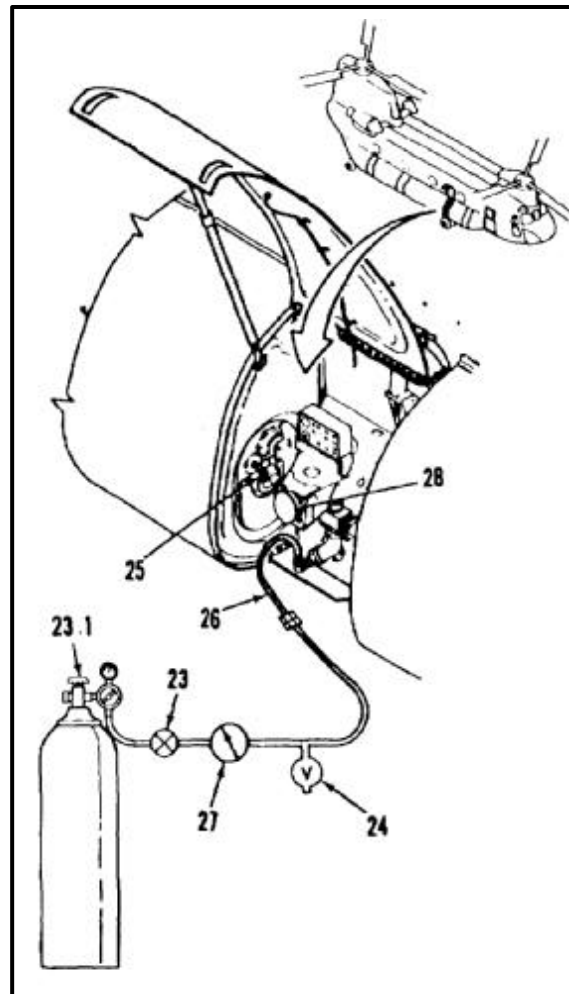

- d. Check manifold (14), tee (29), breakaway fittings (30), check valve (31), and elbows (32) at forward end of main tank (33). Use soap and water mixture as in step 17b.
- e. On aircraft with **68** do a check for leaks as follows. Use soap and water mixture as in step 17b.
 - (1) Check vacuum relief hose fitting (33.1) and nipple (33.2) on bottom of refueling adapter (33.3). If a leak is indicated, tighten or replace fitting or nipple. Replace packing under nipple if necessary.
 - (2) Check vacuum relief valve (33.4) and vacuum relief hose fitting (33.5). Tighten fitting or replace line (33.6) if leakage continues. Proceed as follows if nitrogen is heard escaping from valve.
 - (a) Remove pressure from system.
 - (b) Remove vacuum relief valve (33.4) (Task 10-87.3).
 - (c) Blow low pressure air into screen end (33.7) of relief valve to dislodge any dirt that might be present inside.
 - (d) Apply pressure (air or nitrogen) to fitting end (33.8) of valve and make sure valve holds pressure. If leakage continues, flush valve with solvent (E162), and perform step c again. Replace valve if leakage continues.
 - (e) Install vacuum relief valve (33.4) (Task 10-87.3), and continue leak check of system.

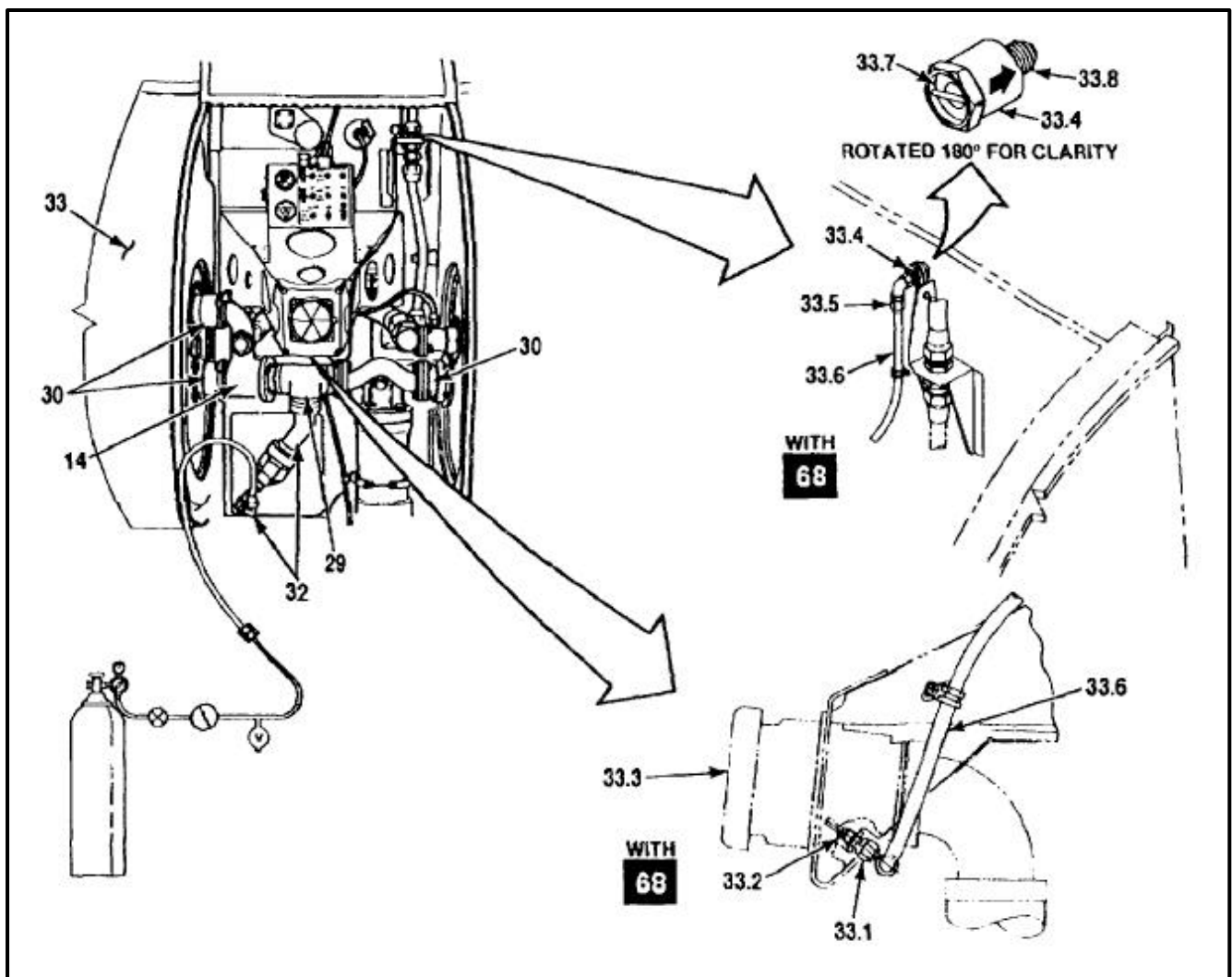

- f. Check breakaway fitting (34) at aft end of main tank (33). Use soap and water mixture as in step 17a.

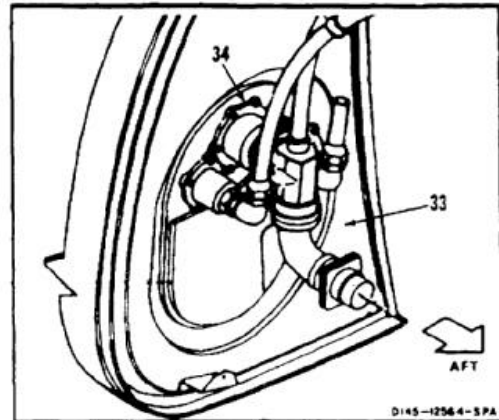

- g. Check motorized valve (35) and two check valves (36) at forward end of aft tank (37). Use soap and water mixture as in step 17a.

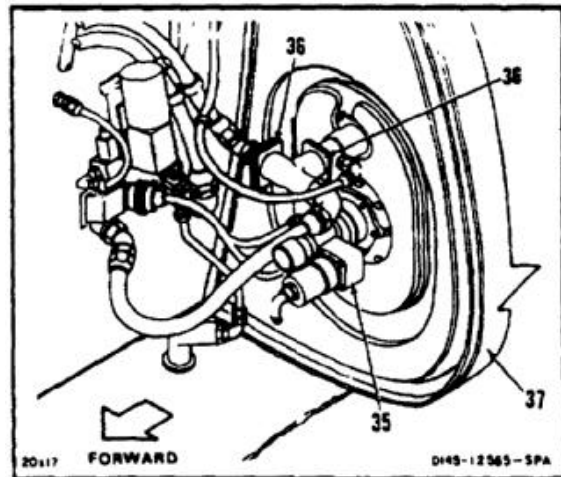

- h. Without **82**, check pressure refueling cross-fuselage tube connection (38) at forward intertank pod area (39). Use soap and water mixture as in step 17a. If pressure continues to drop, go to step 18.
- i. With **82**, check pressure refueling cross-fuselage tube connection (38) and ERFS II refueling hose connections (40). Use soap and water mixture as in step 17a. If pressure continues to drop, go to step 18. Use soap and water mixture as in step 17a. If pressure continues to drop, go to step 18.

NOTE

Valve (40) must be open and the coupling on the inside of the aircraft must be closed in order to do the pressure test with **82** installed.

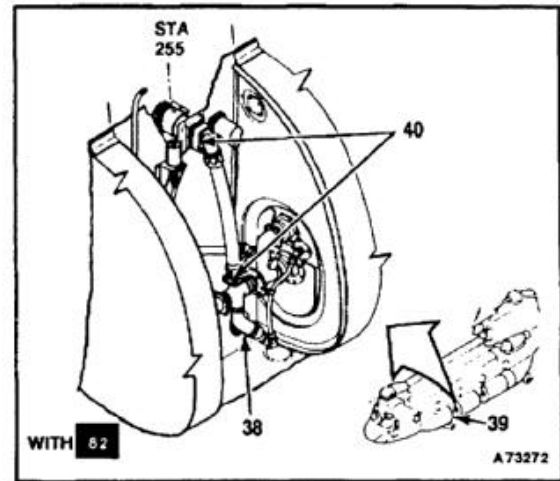

- j. Repeat steps 17e thru 17g for tanks on opposite side of helicopter. If pressure does not drop, go to step 19. If pressure continues to drop, go to step 18.

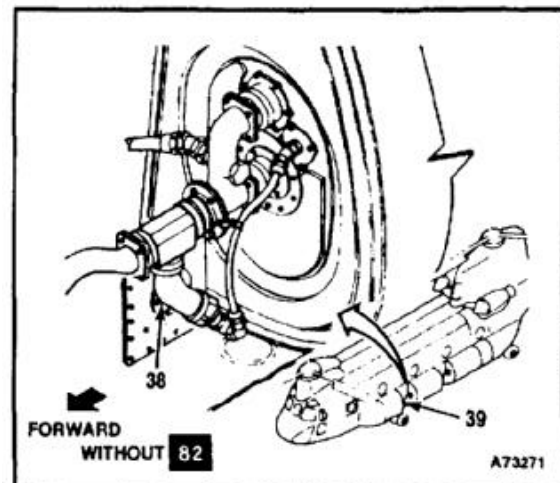

18. At upper end of manifold (14) on both main tanks (33) remove plates (21) and install blanking plates (18) as follows:
- Remove eight nuts (11), bolts (13), and washers (12). Move manifold (14), plates (18 and 21), and gaskets (15 and 16) forward.

CAUTION

Gaskets and plates must be installed in correct order. Otherwise, damage to fittings will result.

- Remove plate (21). Install gasket (17) and plate (18) (APP E17), on lower fitting (19). Install gasket (20) and plate (18) on upper fitting (22). Move manifold (14) and gaskets (15 and 16) aft. Install eight bolt (13) nuts (11), and washers (12).
19. Repeat steps 15 and 16. If gage reads **120 psi**, go to step 21. If gage reads less than **120 psi**, go to step 20.
20. Check pressure refueling tubing and fittings connecting intertank areas through fuselage. Refer to TM 55-1500-204-291.
21. At right main tanks manifold (14), remove eight nuts (11), bolts (13), and washers (12). Slide manifold (14), plates (18 and 20), and gaskets (15 and 16) forward. Repeat steps 9 thru 12.
22. Repeat steps 15 and 16. If gage reads **120 psi**, go to step 24. If gage reads less than **120 psi**, check left main tank (33) for leak. Install blanking plates (18) on right main tank manifold (14), as in step 18.
23. At left main tank manifold (14), remove eight nuts (11), bolts (13), and washers (12). Slide manifold (14), plates (18), and gaskets (15 and 16) forward. Repeat steps 9 thru 12.
24. Repeat steps 15 and 16. If gage reads **120 psi**, go to step 25. If gage reads less than **120 psi**, check right main tank (33) for leaks.

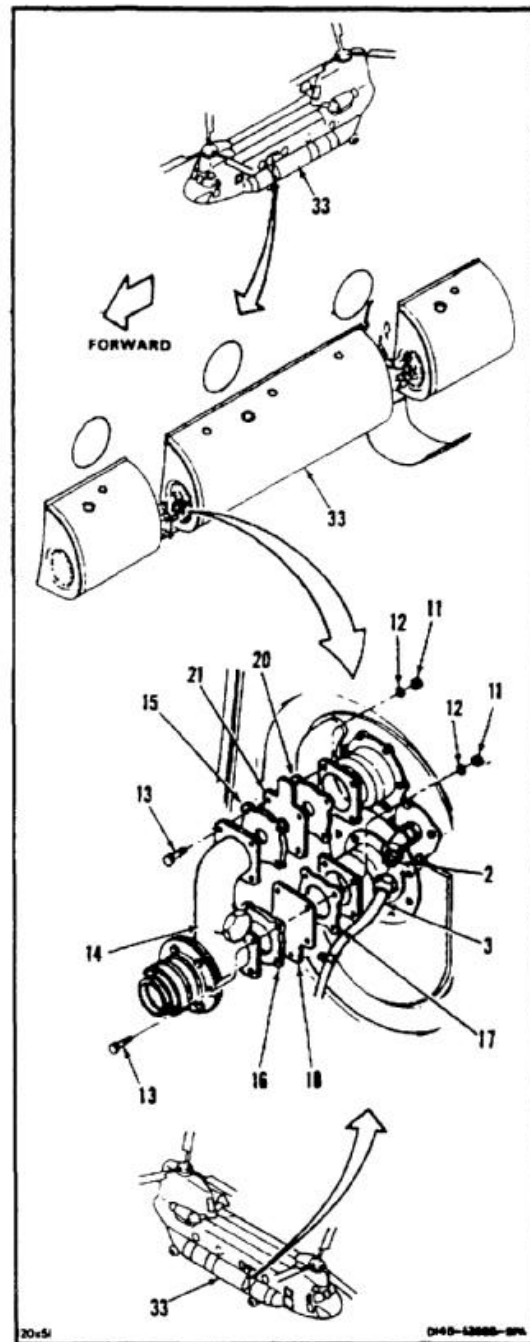

25. Open vent valve (24) to reduce pressure to **0 psi**.
26. Disconnect test setup from hose (26).

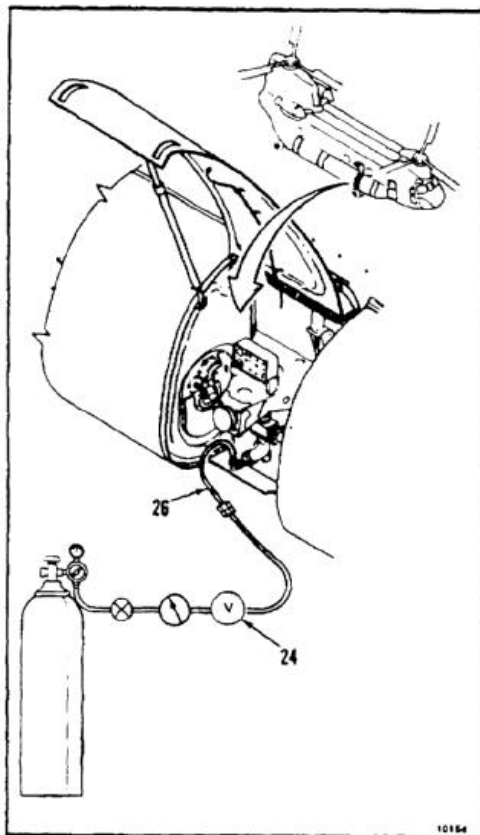

27. Hold fitting (25) with wrench. Connect hose (26).

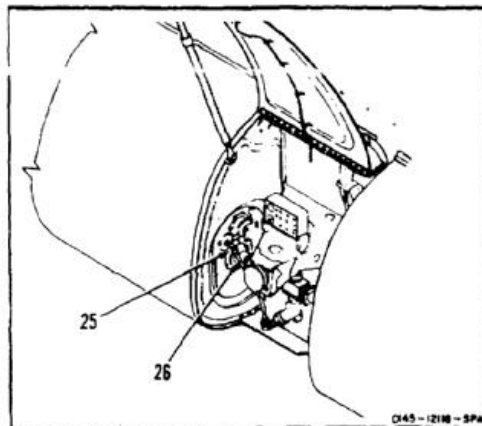

28. Remove plug from hose (3). Hold fitting (2) with wrench and connect hose.
29. Remove eight nuts (11), bolts (13) and washers (12). Slide manifold (14) and gaskets (15 and 16) forward.
30. Remove two plates (18 and 21) and two gaskets (17 and 20).
31. Slide manifold (14) and gaskets (15 and 76) aft and install eight bolts (13), nuts (11), and washers (12).
32. Repeat steps 20 thru 22 on No. 2 main fuel tank.

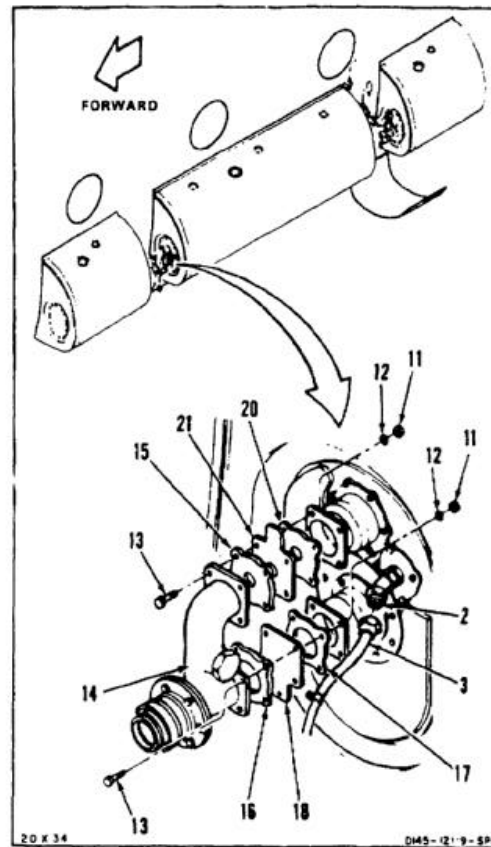

33. Remove four bolts (6), nuts (4), and washers (4). Slide tube (7) and gasket (8) aft and remove gasket (9) and plate (10).
34. Slide tube (7) and gasket (8) forward. Install four bolts (6), nuts (4), and washers (5).
35. Repeat steps 24 and 25 on No. 2 forward fuel tank.

FOLLOW-ON MAINTENANCE:

- Refuel helicopter (Task 1-51).
- Bleed fuel system (Task 10-121).
- Perform operation check of fuel system (TM 55-1520-240-T).
- Install aft intertank pod panel (Task 2-188).
- Close forward landing gear access panel (Task 2-2).

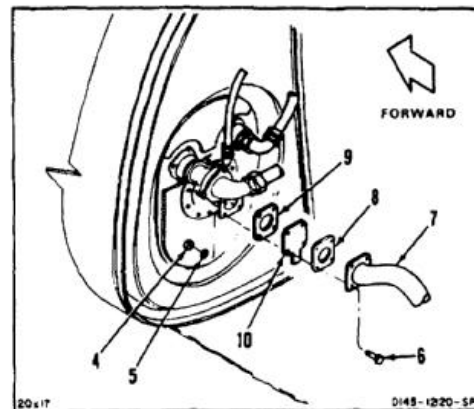

END OF TASK

INITIAL SETUP

Applicable Configurations:

All

Tools:

Aircraft Mechanic's Tool Kit, NSN 5180-00-323-4692
 Nitrogen Supply With Regulator
 Shutoff Valve
 Pressure Gage, 0-100 psi
 Stopwatch, NSN 6645-00-250-4680
 Vent Valve
 Grounded, Container, 2 Quart or Equivalent

Materials:

Cloths (E135)
 Soap (E353)
 Brush (E85)
 Lockwire (E229)
 Lockwire (E231)
 Gloves (E184.1)

Parts:

Plug, AN806-16D (2)
 Plug, AN806-6D (2)

Personnel Required:

Medium Helicopter Repairer
 Inspector

References:

TM 1-1500-204-23

Equipment Condition:

Electrical Power On
 Hydraulic Power Off
 Helicopter Defueled (Task 10-34 or 10-35)
 Aft Intertank Pod Panels Open (Task 2-185)
 Helicopter Grounded (Task 1-29)
 Heater Compartment Acoustic Blanket Removed
 (Task 2-107)
 Cargo Ramp Open and Level (TM 55-1520-240-T)
 Ramp Work Platform Open (Task 2-238)
 APU Drip Pan Removed (Task 2-3)
 Engine Work Platform Open (Task 2-2)
 Engine Access Cover Open (Task 4-49)
 Test Setup

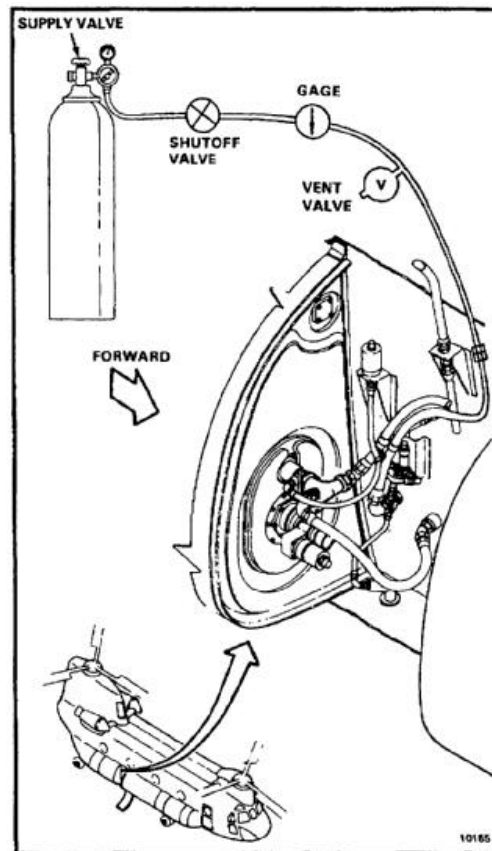
**General Safety Instructions:****WARNING**

All regulations and instructions for handling fuels shall be strictly observed.

CAUTION

Do not allow nipple or fittings to turn when disconnecting fuel lines from aft access panel of tank. Otherwise, access door fittings can fail and cause blockage.

TEST NO. 2 ENGINE AND HEATER FUEL FEED LINES WITHOUT 74

1. Close 14 fuel circuit breakers (1) and APU NORM and EMERG circuit breakers (3) on No. 1 power distribution panel (2).

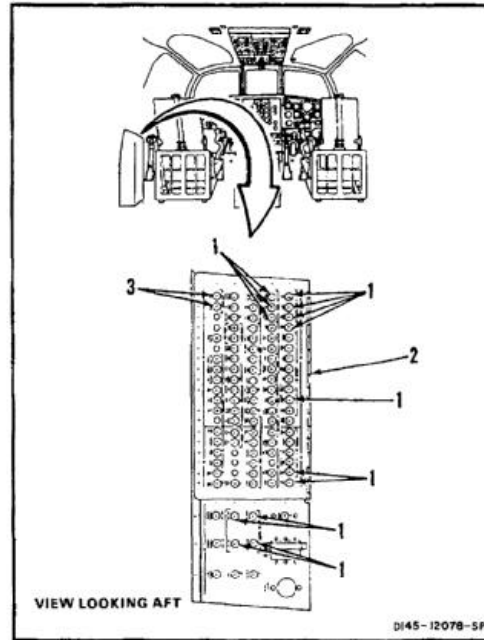

2. Close 10 fuel circuit breakers (4) on No. 2 power distribution panel (5).

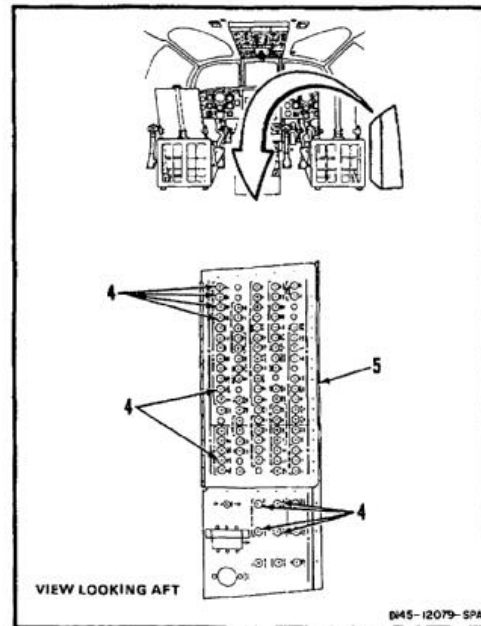

TEST NO. 2 ENGINE AND HEATER FUEL FEED LINES WITH 74

3. Close 11 fuel circuit breakers (1) and APU NORM and EMERG circuit breakers (3) on No. 1 power distribution panel (2).

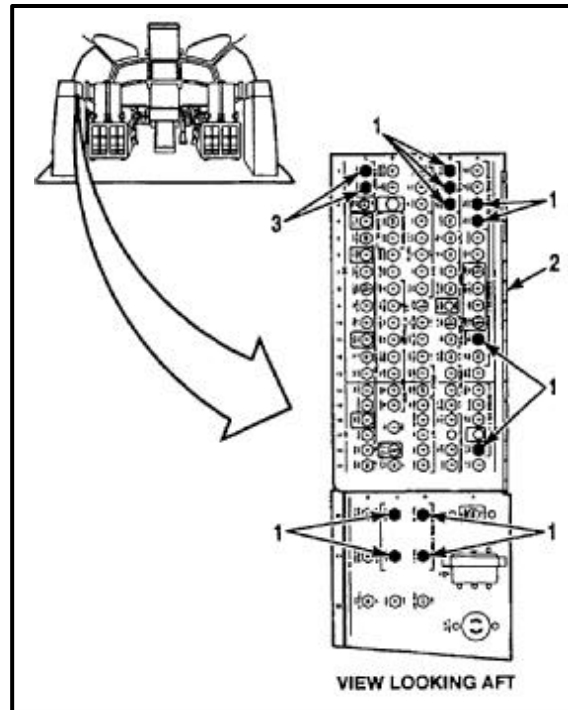

4. Close 8 fuel circuit breakers (4) on No. 2 power distribution panel (5).

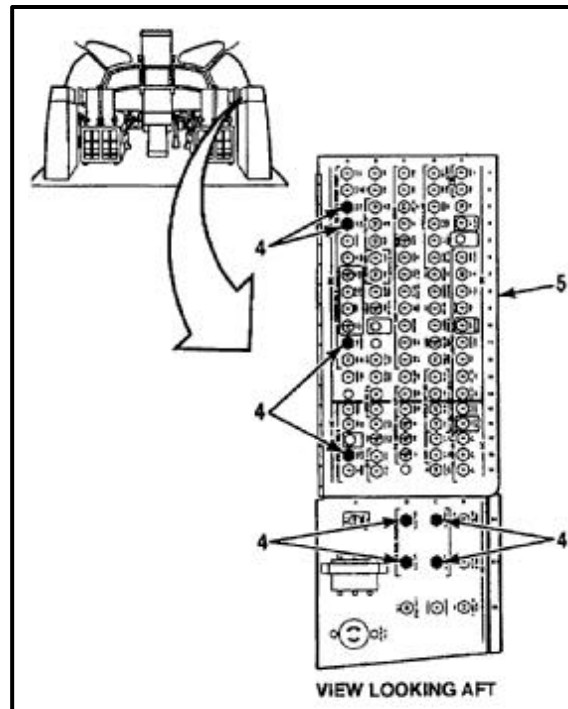

- Put on gloves (E184.1). At aft end of left main tank (6), hold breakaway fitting (7) with wrench and disconnect hose (8). Catch spilled fuel. Use grounded container. Plug hose. Clean up spilled fuel with cloths (E135).

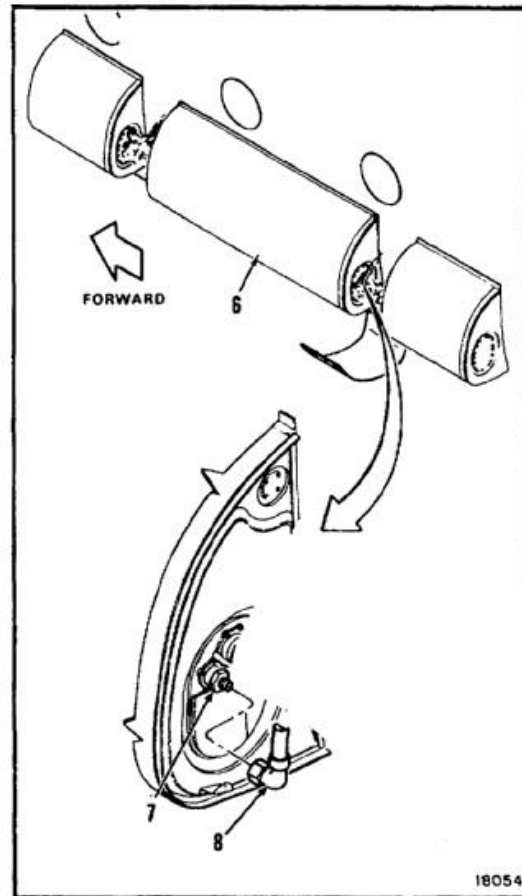

6. Hold fitting (9) with wrench and disconnect hose (10). Catch spilled fuel. Use grounded container. Connect test setup to hose. Clean up spilled fuel with cloths (E135).

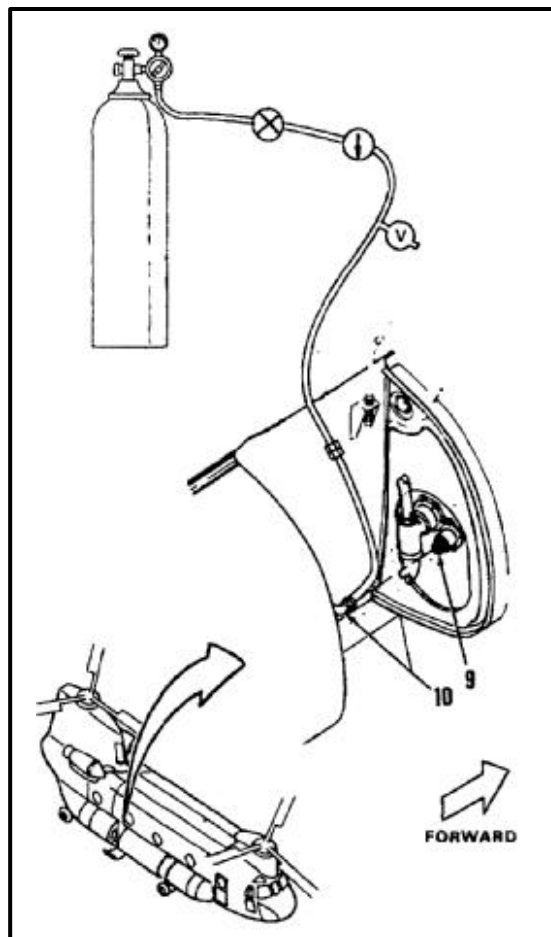

WITHOUT 74

7. Disconnect fuel hose (11) from fuel boost pump (12) on No. 2 engine (13). Catch spilled fuel. Use grounded container. Clean up spilled fuel with cloths (E135).
8. Repeat step 7 on No. 1 engine (14).

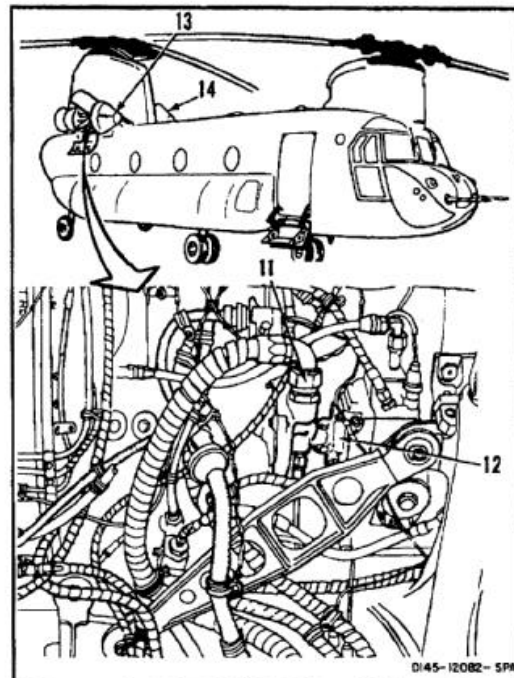
**WITH 74**

9. Disconnect fuel hose (11) from fuel boost pump (12) on No. 1 engine (13). Catch spilled fuel. Use grounded container. Clean up spilled fuel with cloths (E135).
10. Repeat step 9 on No. 1 engine (14).

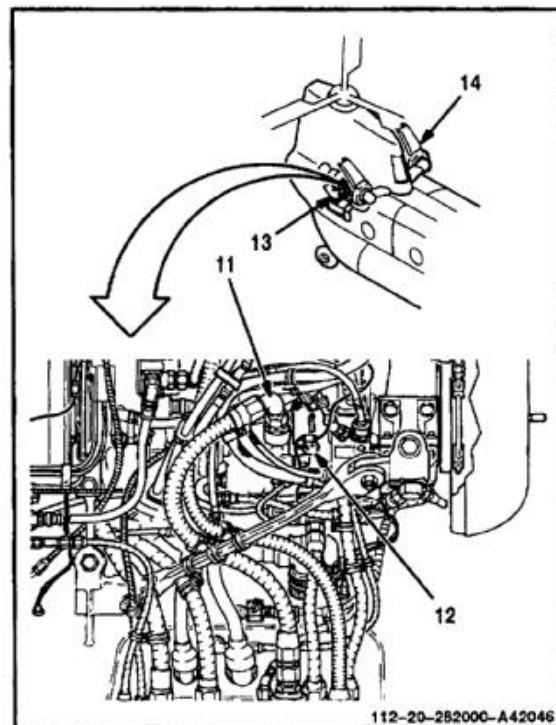

11. Disconnect fuel hose (15) from port (16) on APU (17). Catch spilled fuel in grounded container. Clean up spilled fuel with cloths (E135).

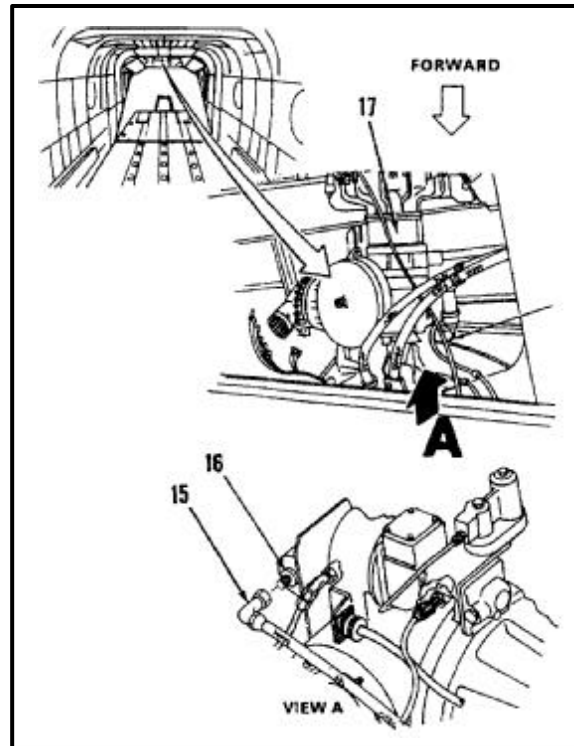

12. Disconnect fuel hose (18) from port (19) on heater fuel control (20). Catch spilled fuel in grounded container. Clean up spilled fuel with cloths (E135).

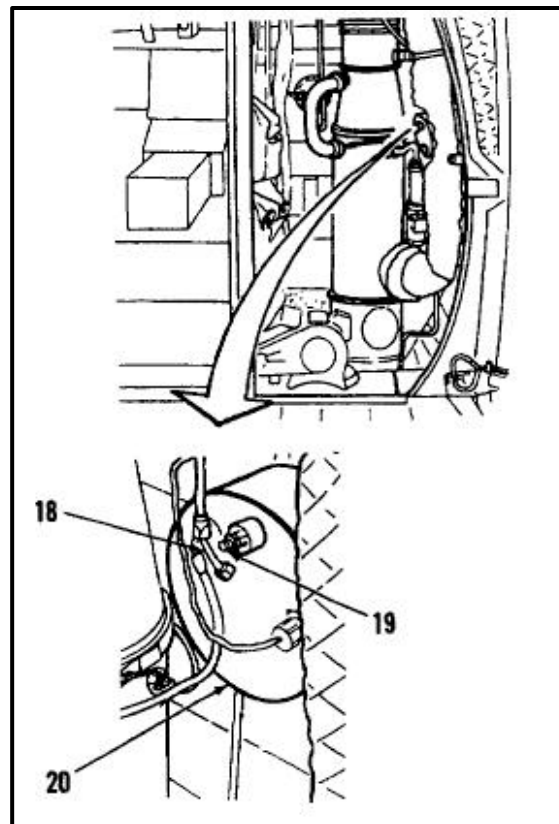

13. Set CROSSFEED FUEL VALVE switch (21) to CLOSE.

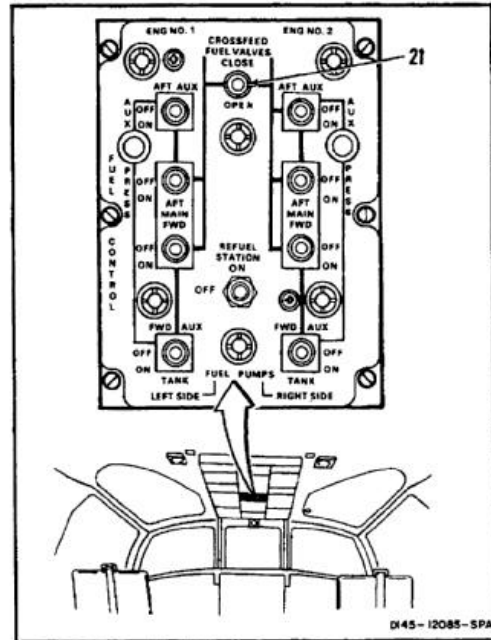

14. Make sure FIRE EXTINGUISHER AGENT switch (22) is set to OFF.
15. Pull out right side FIRE PULL handle (23).

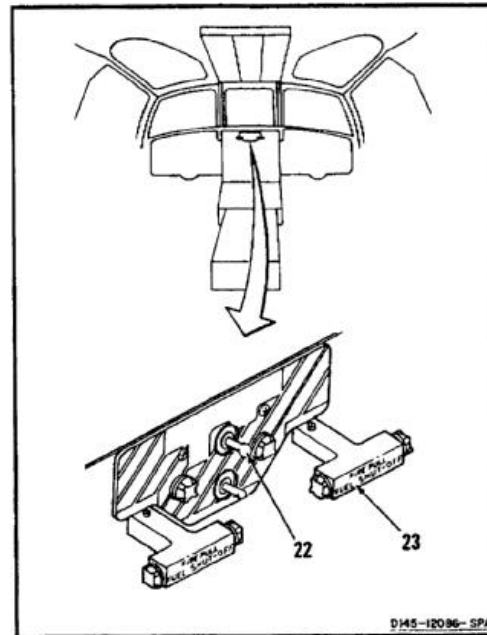

16. Close valves (24 and 26). Open valve (24.1) and regulate pressure to **30 psi**. Open valve (24) and stabilize pressure to **30 psi** on gage (25). Close valve (24).
17. Wait **5 minutes** and check gage (25). If gage indicates **30 psi**, go to step 19. If gage does not indicate **30 psi**, go to step 18.

CHECK NO. 2 ENGINE AND HEATER LINES FOR LEAKS

18. Check for leaks as follows:
 - a. Check test connections upstream and downstream of valves (24 and 26) and gage (25). Use mixture of soap (E353) and water, and brush (E85).
 - b. Check connections at heater fuel solenoid valve (27) between right main (28) and right aft (29) tanks. Use soap and water solution as in step 18a.
 - c. Check No. 2 engine fuel feed connection at check valve (30) and crossfeed motorized shutoff valve (31). Use soap and water mixture as in step 18a.

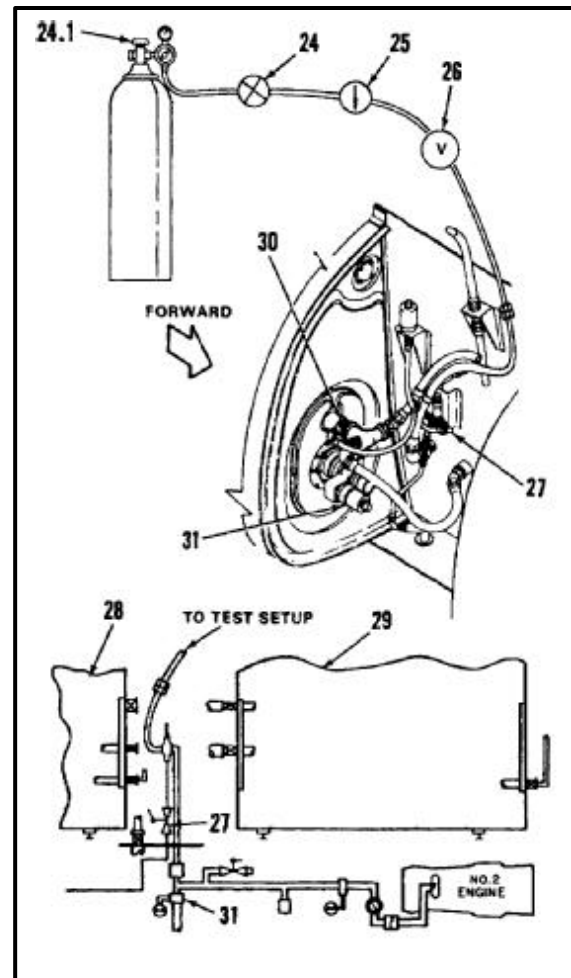

- d. Check connections at manual drain valve (32), pressure switch (33), and engine motorized shutoff valve (34). Use soap and water mixture as in step 18a.
- e. Check tubing, hoses, and fittings. Refer to TM 1-1500-204-23.

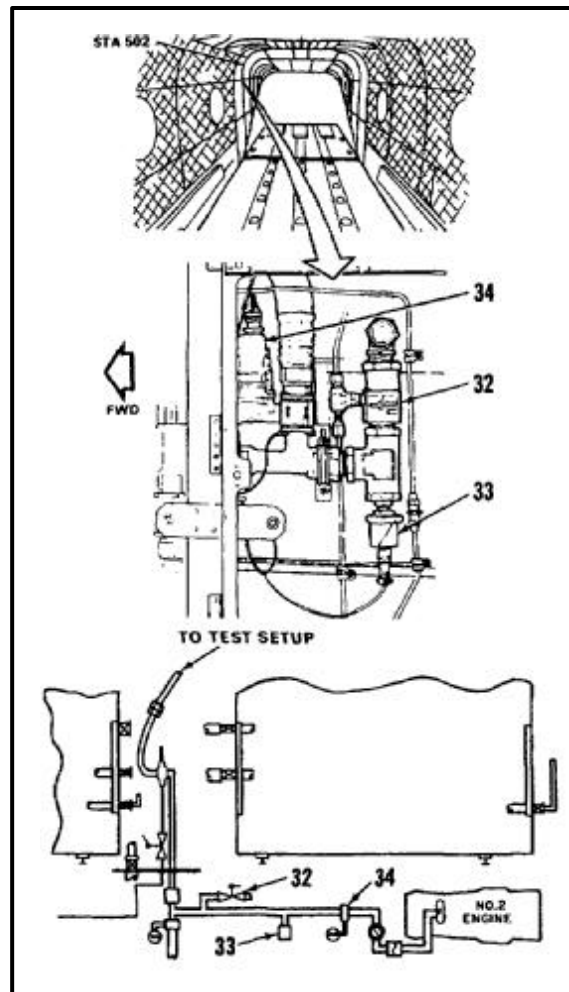

19. Push in right side FIRE PULL handle (23).

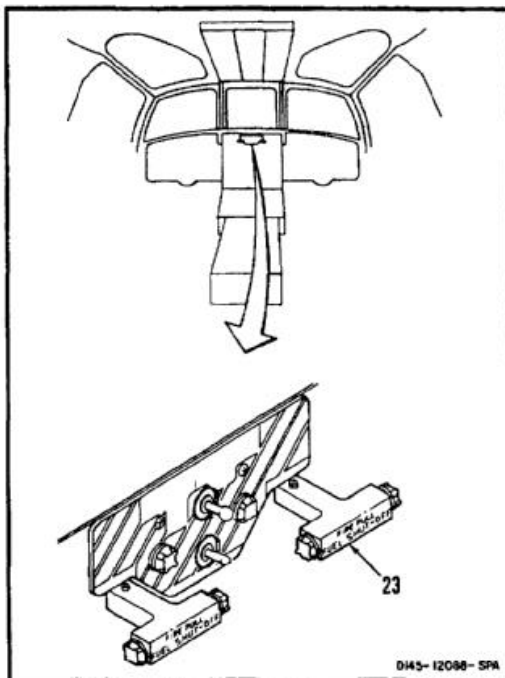

WITHOUT 74

20. Plug No. 2 engine fuel hose (11).

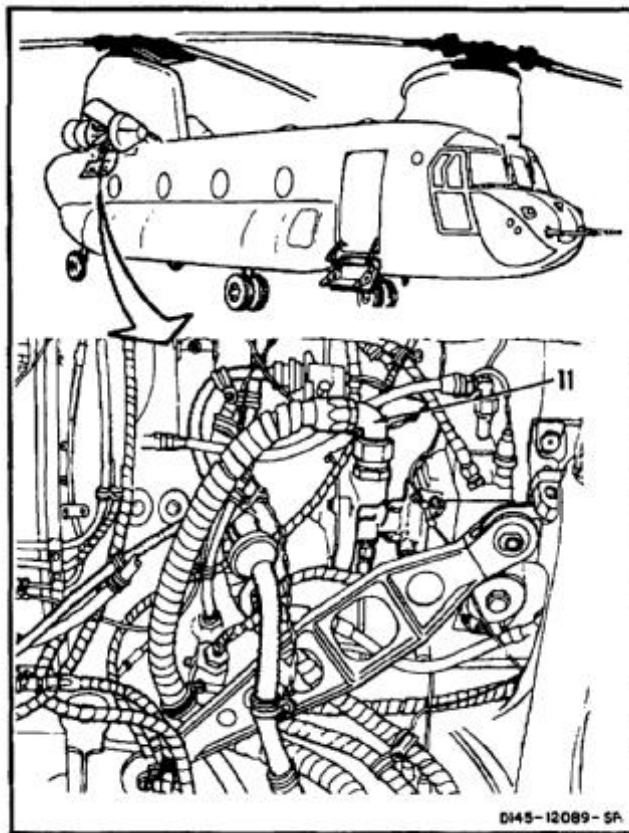

WITH **74**

21. Plug No. 2 engine fuel hose (11).

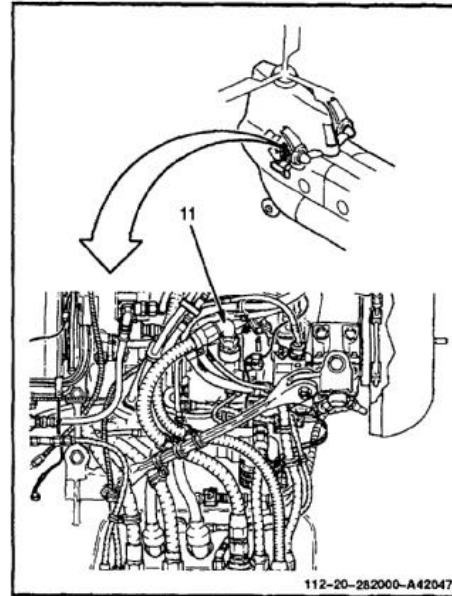

- 22. Set CROSSFEED FUEL VALVE switch (21) to OPEN.

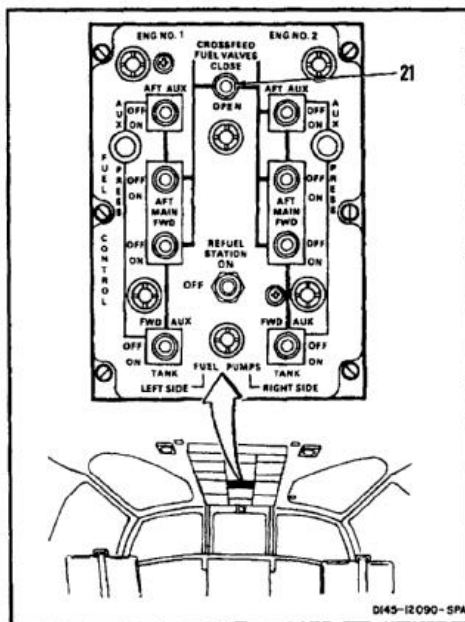

- 23. Pull out left side FIRE PULL handle (35).

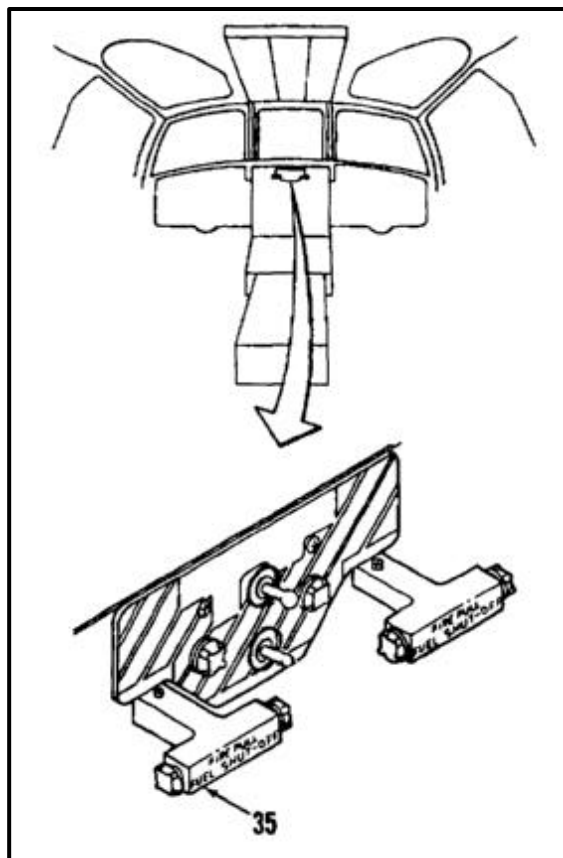

24. Close valves (24 and 26). Open valve (24.1) and regulate pressure to **30 psi**. Open valve (24) and stabilize pressure to **30 psi** on gage (25). Close valve (24).
25. Wait **5 minutes** and check gage (25). If gage indicates **30 psi**, go to step 27. If gage does not indicate **30 psi**, go to step 26.

CHECK NO. 1 ENGINE AND ENGINE CROSSFEED LINES FOR LEAKS

26. Check for leaks as follows:
 - a. Check that plug installed in step 20 or 21 is secure. Use soap and water mixture as in step 18a.

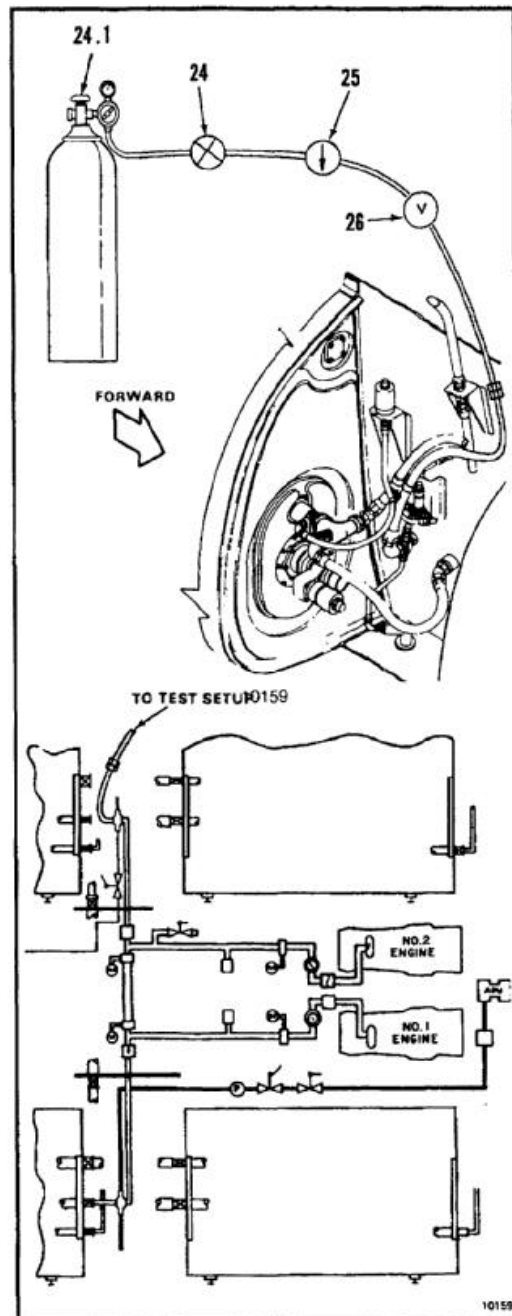

- b. Check No. 1 engine fuel feed connections at check valve (36) in left aft intertank area (37). Use soap and water mixture as in step 18a.
- c. Check crossfeed fuel connections at motorized shutoff valve (38). Use soap and water mixture as in step 18a.

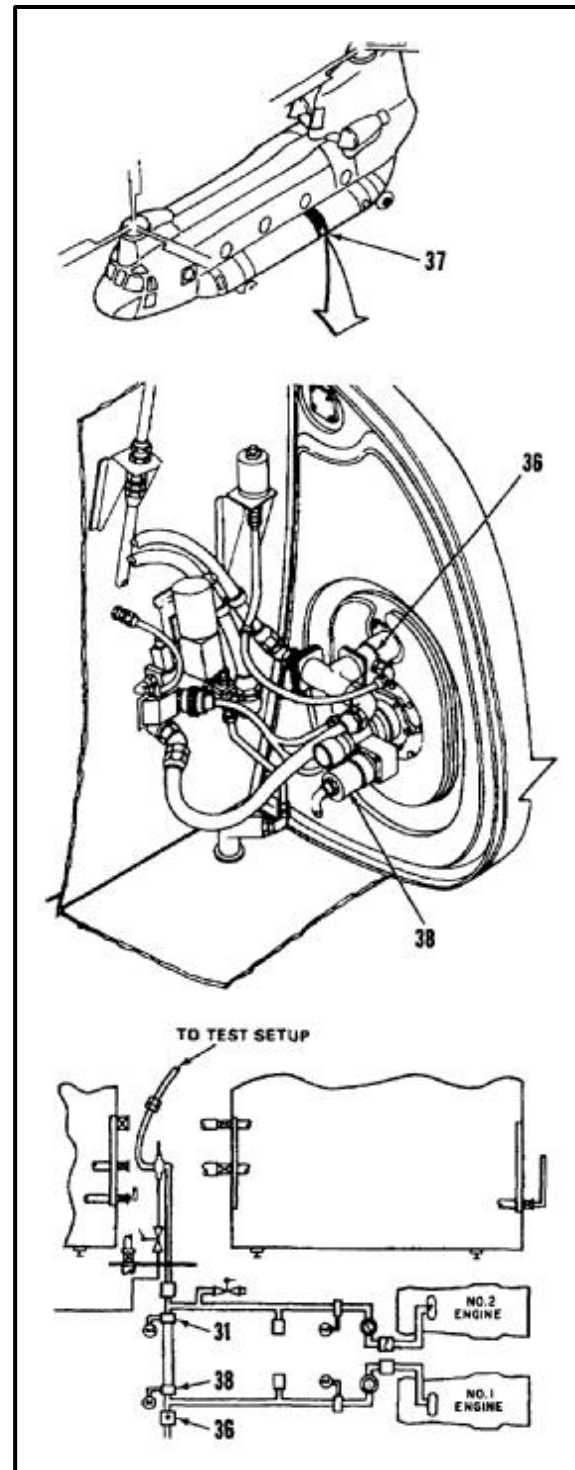

- d. Check connections at pressure switch (39) and engine motorized shutoff valve (40). Use soap and water mixture as in step 18a.
- e. Check tubing, hoses, and fittings. Refer to TM 1-1500-204-23.

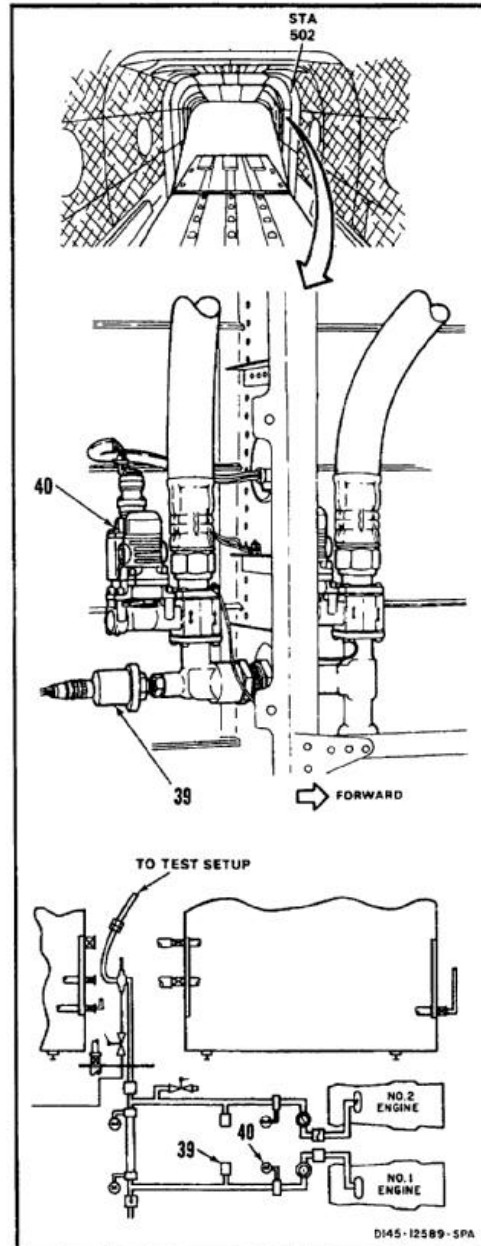

TEST NO. 1 ENGINE FUEL FEED LINE BETWEEN SHUTOFF VALVE AND ENGINE

27. Push left side FIRE PULL handle (35).

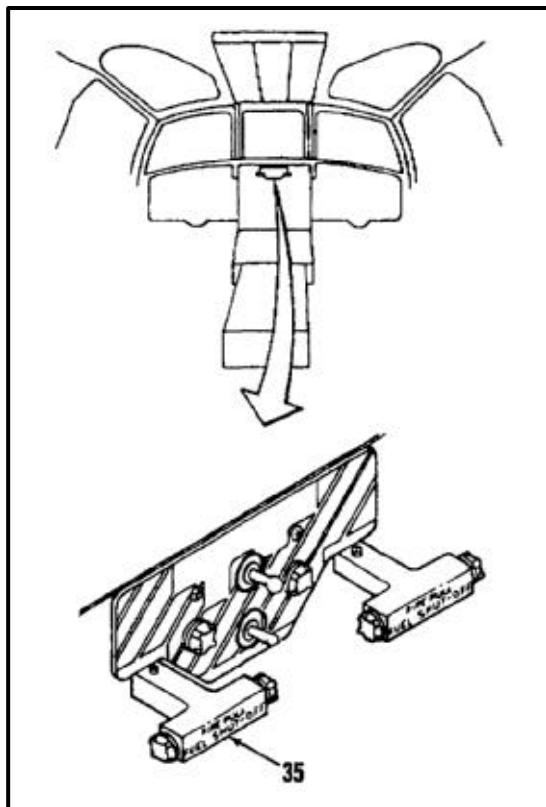

28. Plug No. 1 engine fuel hose (41).

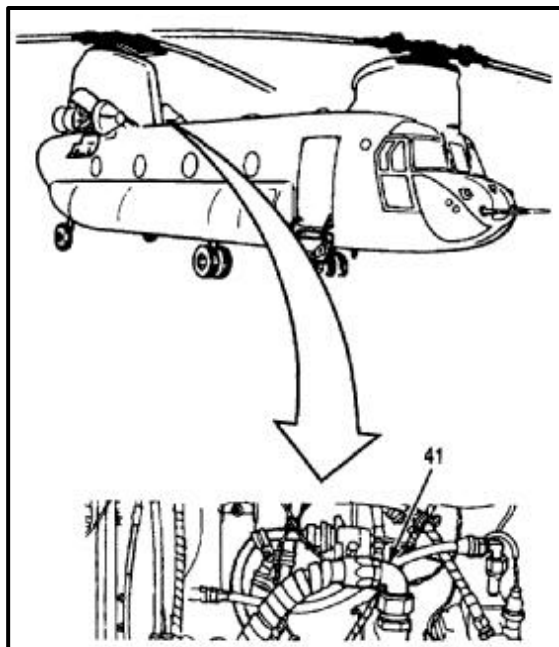

29. Close valves (24 and 26). Open valve (24.1) and regulate pressure to **60 psi**. Open valve (24) and stabilize pressure to **60 psi** on gage (25). Close valve (24).
30. Wait **5 minutes** and check gage (25). If gage indicates **60 psi**, go to step 32. If gage does not indicate **60 psi**, go to step 31.

CHECK FOR LEAKS BETWEEN SHUTOFF VALVE AND NO. 1 ENGINE

31. Check for leaks as follows:
 - a. Check connectors between shutoff valve (40) and No. 1 engine (14). Use soap and water mixture as in step 18a.
 - b. Check tubing, hoses, and fittings between shutoff valve (40) and No. 1 engine (14). Refer to TM 1-1500-204-23.

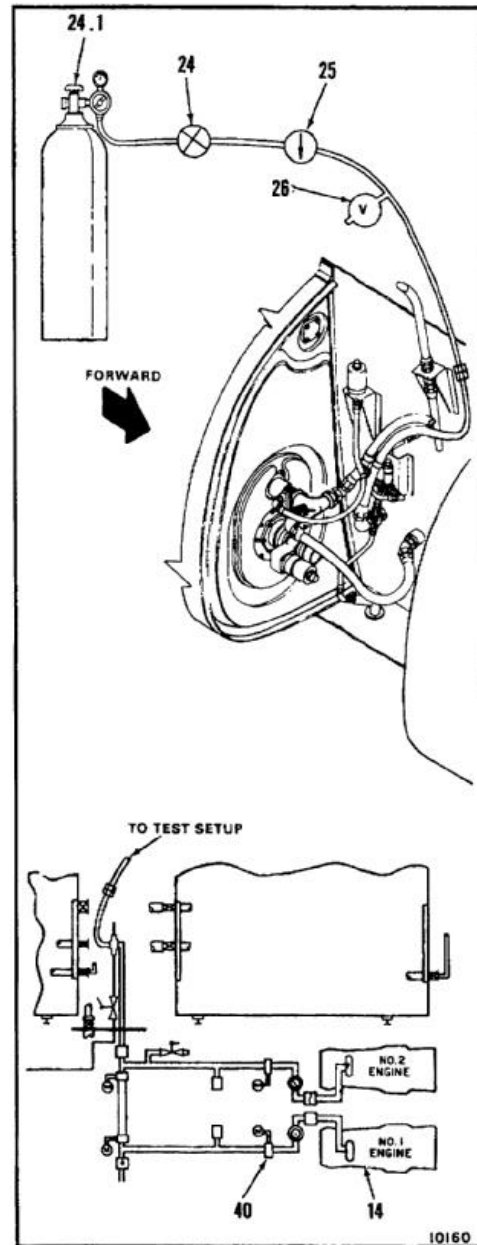

TEST FUEL FEED LINE BETWEEN SHUTOFF VALVE AND HEATER

- 32. Remove lockwire and disconnect electrical connector (42) from heater fuel control (43).
- 33. Remove lockwire and disconnect electrical connector (44) from heater ignition unit (45).

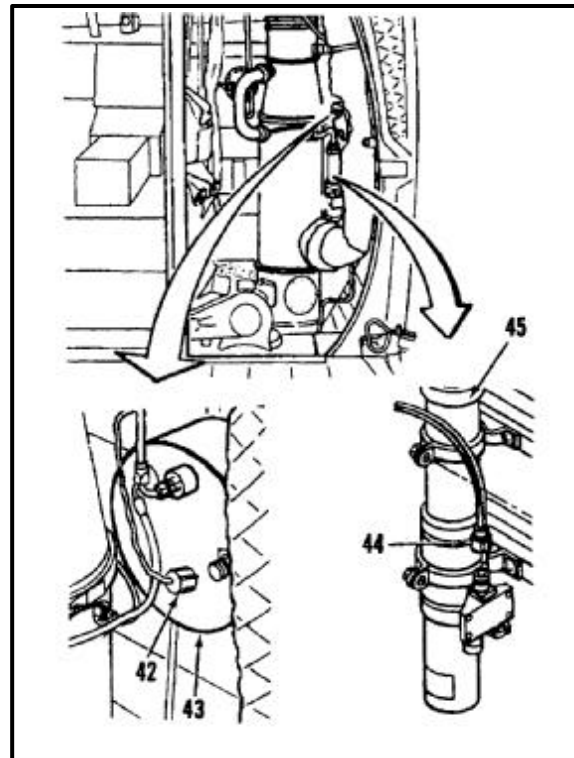

- 34. Set switch (46) on HEATING panel (47) to HEATER ON.
- 35. Push HEATER START switch (48).

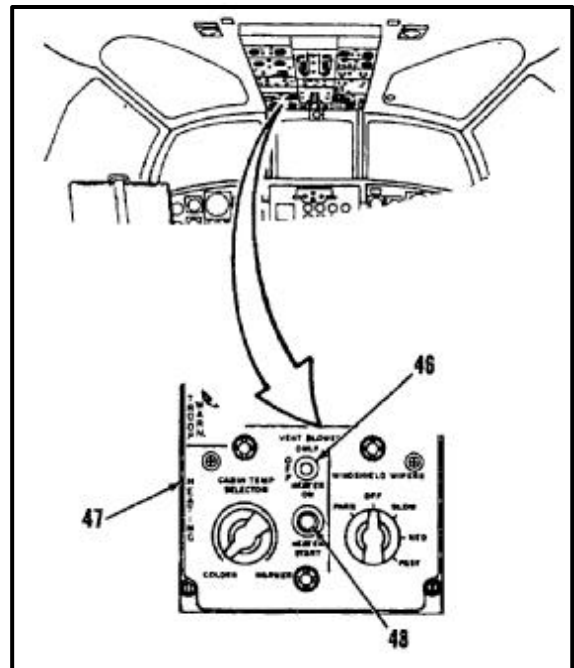

36. Plug fuel hose (18) at heater fuel control (20).
37. Close valves (24 and 26). Open valve (24.1) and regulate pressure to **60 psi**. Open valve (24) and stabilize pressure to **60 psi** on gage (25). Close valve (24).
38. Wait **5 minutes** and check gage (25). If gage indicates **60 psi**, go to step 40. If gage does not indicate **60 psi**, go to step 39. Check for leaks between shutoff valve and heater.
39. Check tubes, hoses, and fittings between heater fuel solenoid valve (27) and heater (20).

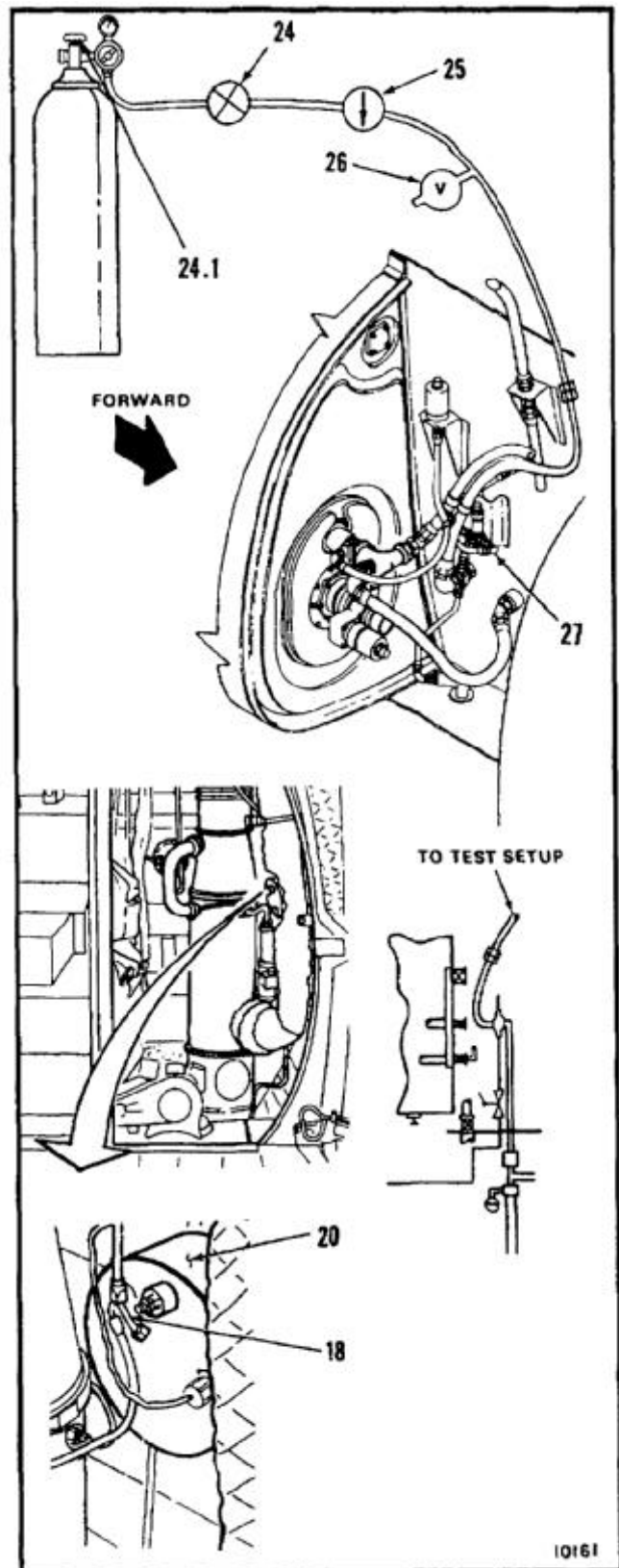

TEST APU FUEL LINE

- 40. Disconnect electrical connector (49) from APU fuel boost pump (50).

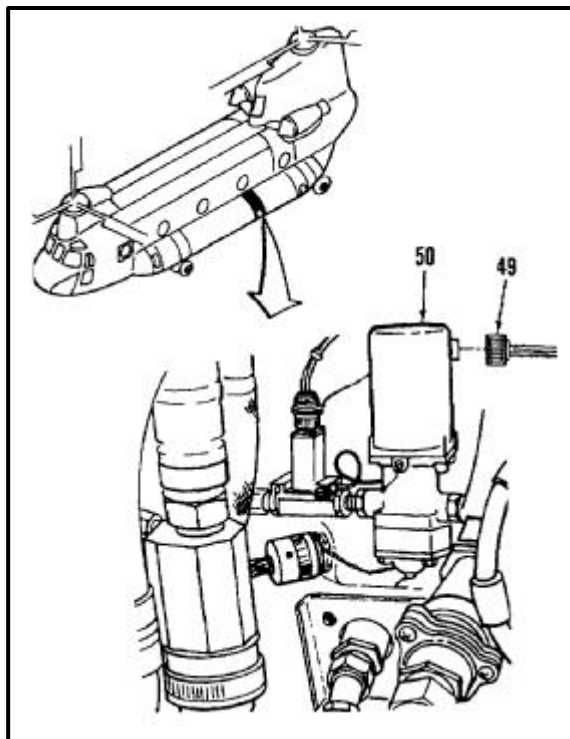

- 41. Set APU switch (51) to RUN.

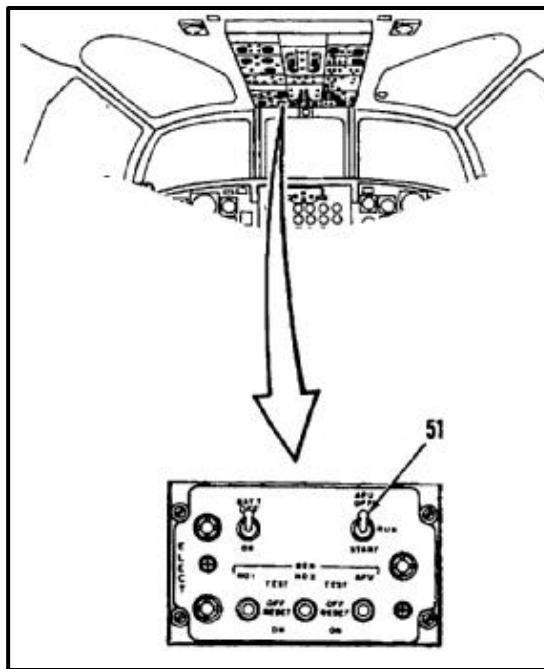

42. Plug fuel hose (52) at APU (17).

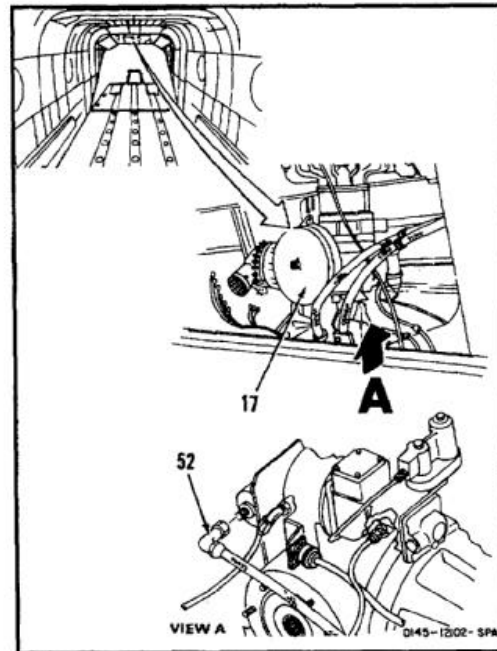

43. Close valves (24 and 26). Open valve (24.1) and regulate pressure to **60 psi**. Open valve (24) and stabilize pressure to **60 psi** on gage (25). Close valve (24).
44. Wait **5 minutes** and check gage (25). If gage indicates **60 psi**, go to step 46. If gage does not indicate **60 psi**, go to step 45.

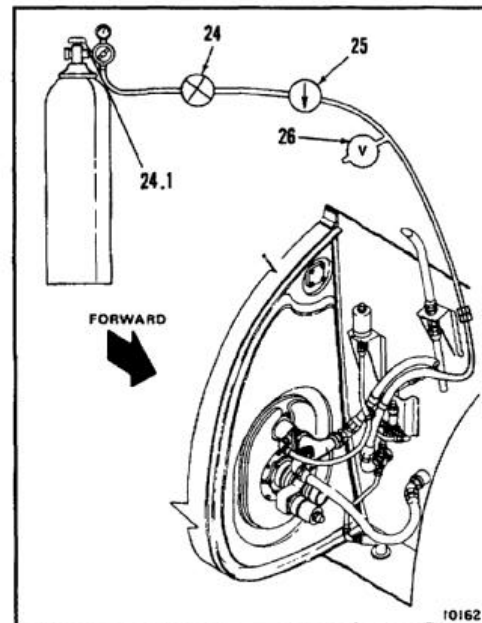

CHECK FOR LEAKS AT APU FUEL FEED LINE

45. Check for leaks at boost pump (50) and solenoid shutoff valve (53). Use soap and water mixture as in step 18a.

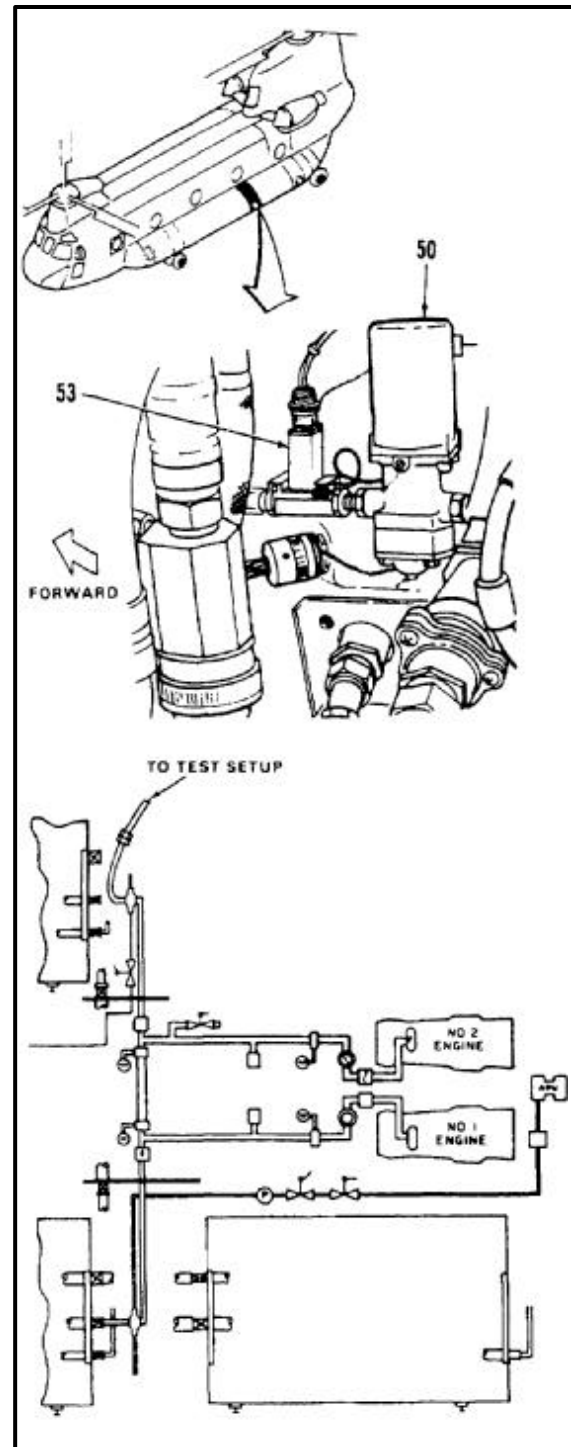

46. Check connections at APU manual shutoff valve (54). Use soap and water mixture as in step 18a.
47. Check tubing, hoses, and fittings. Refer to TM 1-1500-204-23.

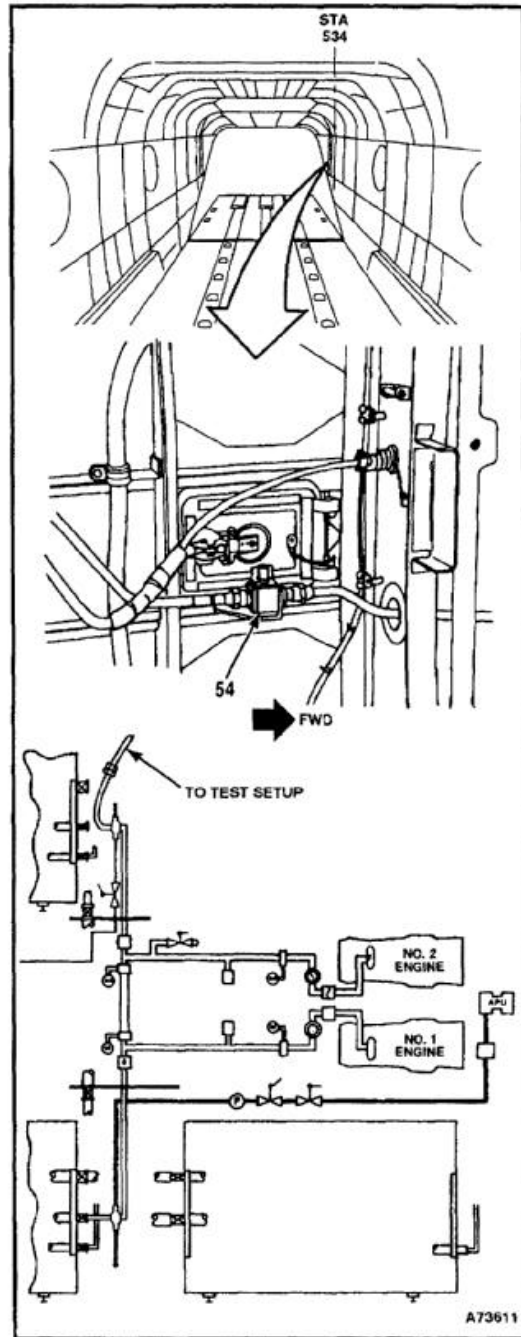

REMOVE TEST SETUP AND CONNECT FUEL FEED SYSTEM

- 48. Open vent valve (26) and reduce pressure to **0 psi**. Disconnect test setup.
- 49. Hold fitting (9) with wrench and connect hose (10).

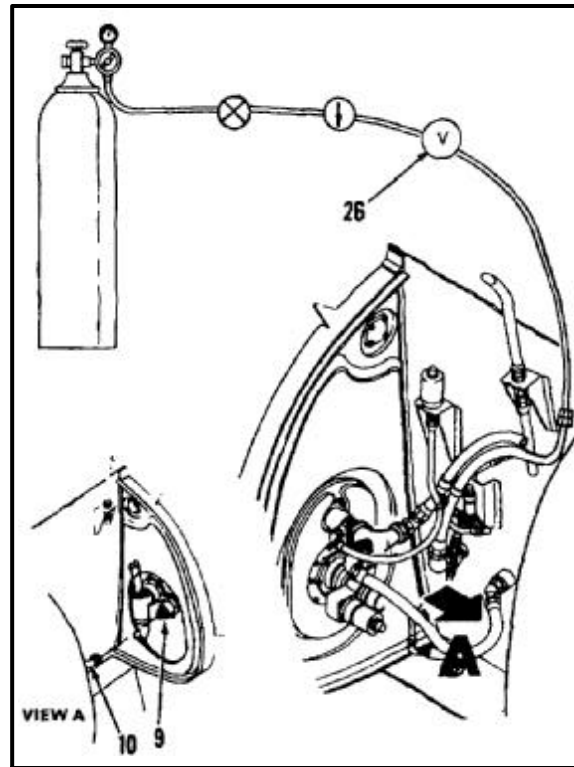

- 50. Remove plug from APU fuel hose (52). Connect hose to port (55) on APU (17).

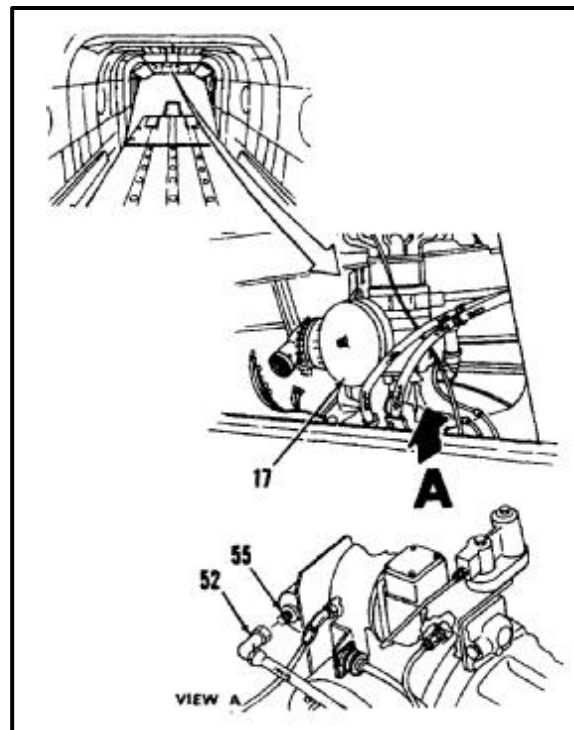

51. Connect electrical connector (49) to APU fuel boost pump (50).
52. Remove plug from hose (8).
53. Hold filling (7) with wrench and connect hose (8).

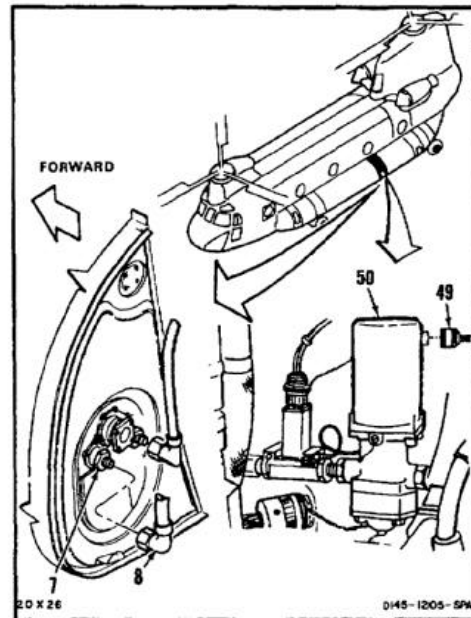

WITHOUT 74

54. Remove plug from fuel hose (11) on No. 2 engine (14). Connect hose to port (56) on fuel boost pump (12).
55. Repeat step 54 on hose (41) at No. 1 engine (13).

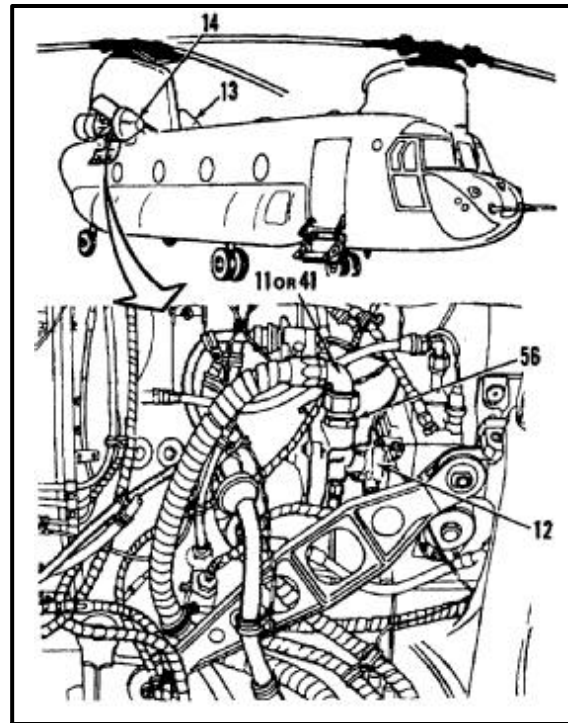
**WITH 74**

56. Remove the plug from fuel hose (11) on No. 2 engine (14). Connect hose to port (56) on fuel boost pump (12).
57. Repeat step 56 on hose (41) at No. 1 engine (13).

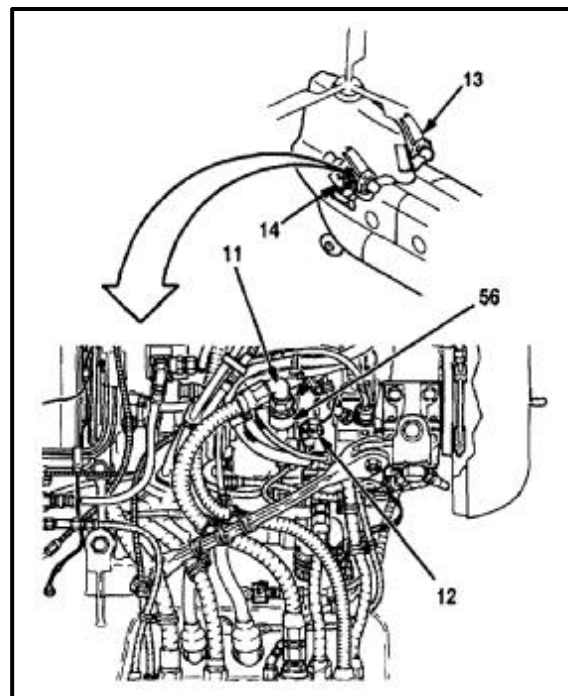

- 58. Remove plug from heater fuel hose (18).
- 59. Connect fuel hose (18) to port (19) on heater fuel control (20).

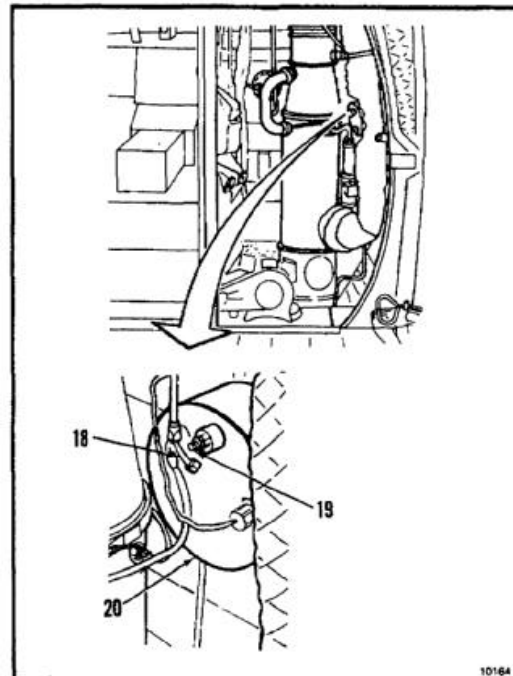

- 60. Set CROSSFEED FUEL VALVE switch (21) to CLOSE.
- 61. Set switch (46) on HEATING panel (47) to OFF.

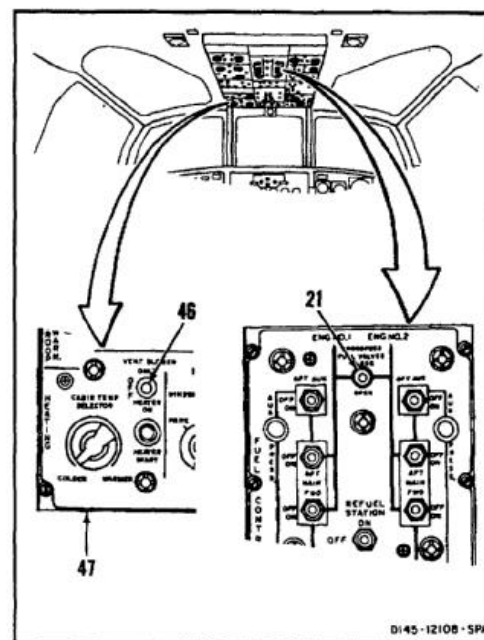

62. Connect electrical connector (42) to receptacle (57) on heater fuel control (43). Lockwire connector. Use lockwire (E229).
63. Connect electrical connector (44) to receptacle (58) on heater ignition unit (45). Lockwire connector. Use lockwire (E231).
64. Remove electrical power.

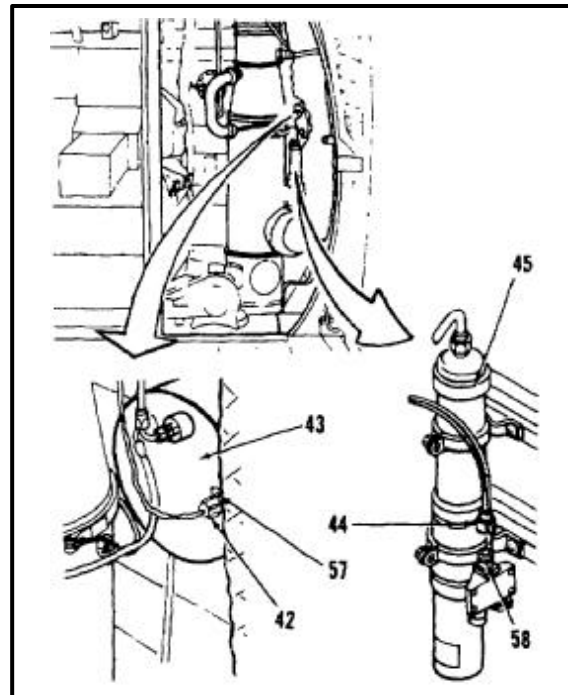

FOLLOW-ON MAINTENANCE:

- Install heater compartment acoustic blanket (Task 2-108).
- Close ramp work platform (Task 2-244).
- Install APU drip pan (Task 2-3).
- Cargo ramp closed (TM 55-1520-240-T).
- Close engine access cover (Task 4-50).
- Close engine work platform (Task 2-2).
- Service fuel system (Task 1-51).
- Bleed fuel system (Task 10-121).
- Perform operational check of fuel system (TM 55-1520-240-T).
- Inspect for leaks (Task 10-4).
- Close aft intertank pod panels (Task 2-188).

END OF TASK

INITIAL SETUP

Applicable Configurations:

All

Tools:

Aircraft Mechanic's Tool Kit, NSN 5180-00-323-4692
 Workstand
 Wrench, Open End, 1 Inch (2)
 Drain Hose (2) — Approximately 16 Feet Long, One
 End To Have Male Adapter 7/8-14UNJ-3A
 Drain Hose — Approximately 16 Feet Long, One End
 To Have Male Adapter 9/16-1UNJF-3A
 Grounded Container, 50 Gallon or Equivalent

Materials:

Cloths (E135)
 Gloves (E184.1)

Personnel Required:

Medium Helicopter Repairer (2)
 Inspector

References:

Task 1-37

Equipment Condition:

Helicopter Refueled
 Battery Disconnected (Task 1-39)
 Electrical Power Off
 Helicopter Grounded (Task 1-29)
 Engine Work Platform Open (Task 2-2)
 Engine Access Cover Open (Task 4-49)
 Ramp Open (TM 55-1520-240-T)

General Safety Instructions:**WARNING**

All regulations and instructions for handling fuels shall be strictly observed.

WARNING

Fuel is combustible and poisonous. It can cause skin irritation and burns. Use it only with sufficient external airflow, away from an open flame. If it touches your skin or eyes, immediately flush them with water for a minimum of **15 minutes**. Get medical attention for your eyes.

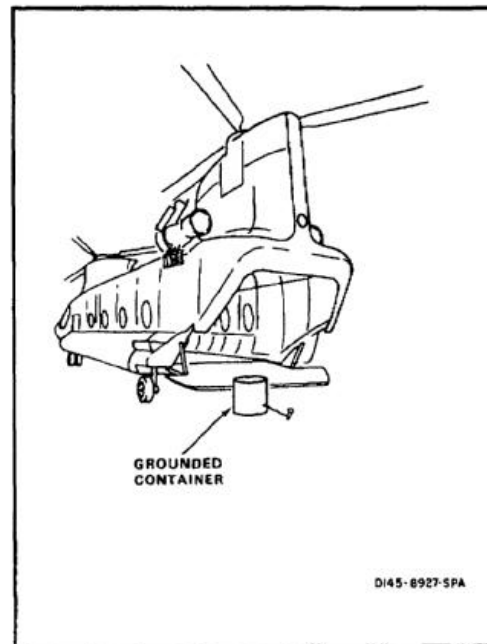

1. Disconnect fuel hose (1) from engine fuel control nipple (2) on both engines (3). Cap the nipple on fuel control.
2. Attach grounding wire (6) on each drain hose (4) to grounded container (5).
3. Connect one drain hose (4) to fuel hose (1) on each engine (3). Place the free end of each drain hose in grounded container (5).

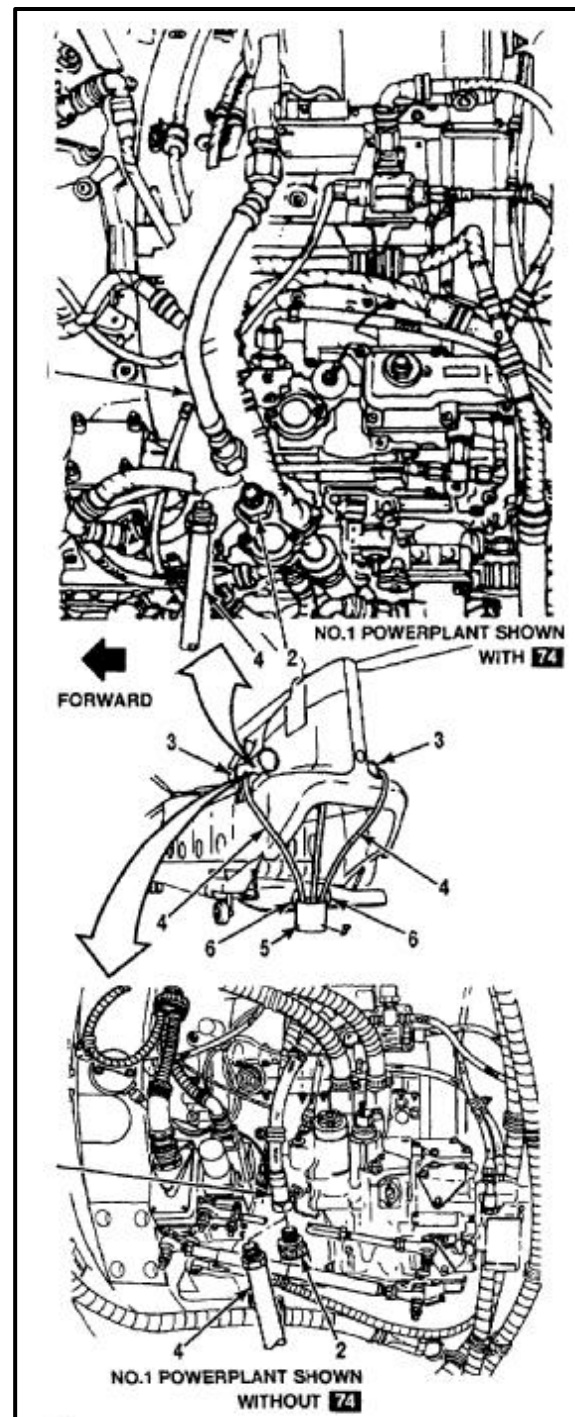

4. Position workstand. Disconnect electrical connector (7) from APU start module (8).
5. Disconnect fuel hose (9) from filter adapter (10) on APU (11). Cap adapter.
6. Connect drain hose (12) to fuel hose (9).

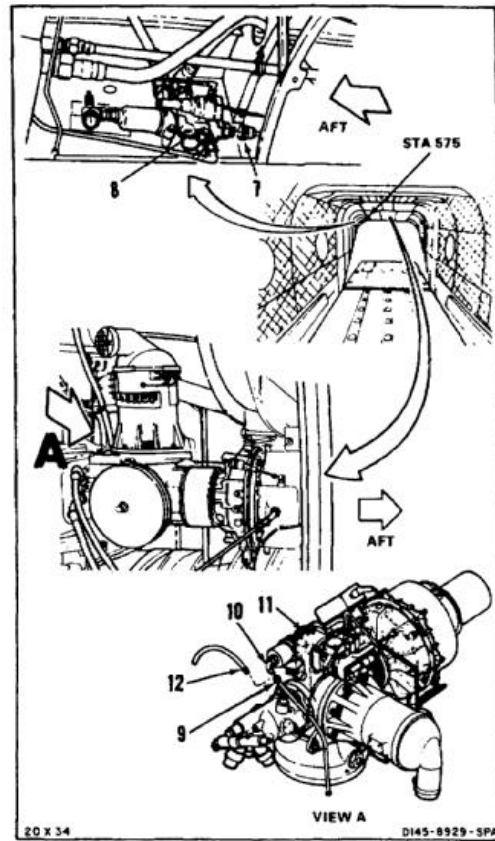

7. Place free end of drain hose (12) in grounded container (5). Attach grounding wire (13) to container.
8. Apply ac power to helicopter (Task 1-37).

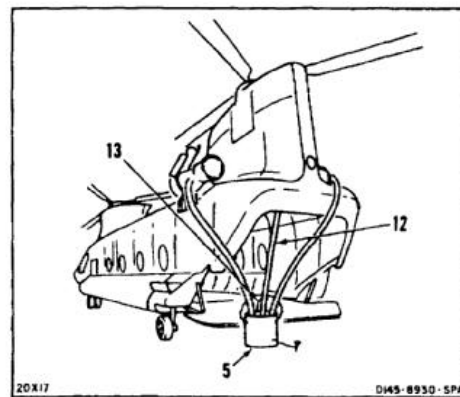

9. In cockpit, on No. 1 PDP (14), make sure that following circuit breakers are closed (pushed in):
 - LH FUEL PUMP CONT
 - MAIN AFT (15)
 - MAIN FWD (16)
 - LH FUEL PUMPS
 - MAIN FWD (17)
 - MAIN AFT (18)
 - APU CONT
 - NORM (19)
 - EMERG (20)
 - ENGINE No. 1 FUEL SHUTOFF (21)
 - FUEL XFEED CONT (22)
10. On No. 2 PDP (23), make sure that following circuit breakers are closed (pushed in):
 - RH FUEL PUMP CONT
 - MAIN AFT (24)
 - MAIN FWD (25)
 - RH FUEL PUMPS
 - MAIN FWD (26)
 - MAIN AFT (27)
 - ENGINE No. 2 FUEL SHUTOFF (28)
 - PRI CONT (40) (With 74)
 - REV CONT (41) (With 74)
11. On Fuel Control Panel (29), set CROSSFEED FUEL VALVES switch (30) to CLOSE.

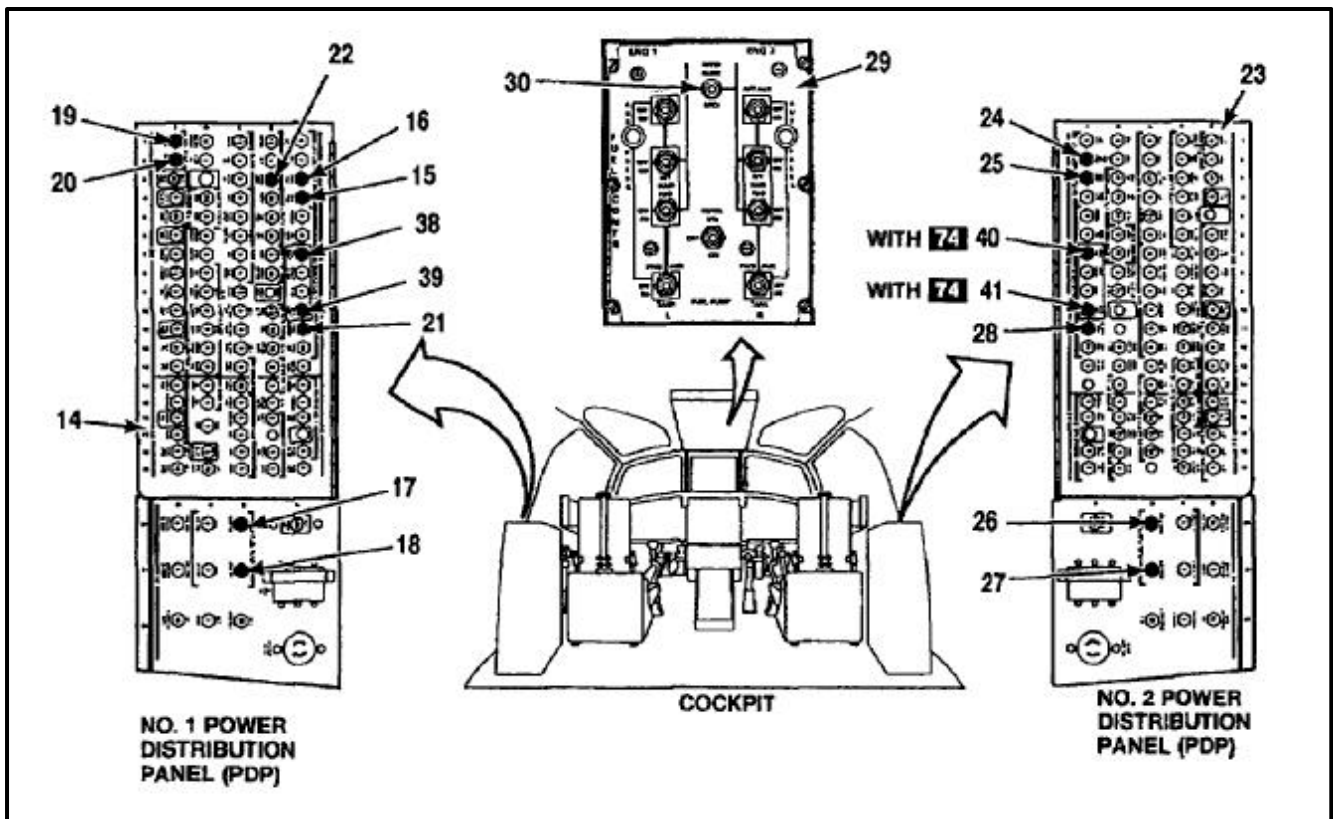

12. Close APU fuel shutoff valve (31).
13. Manually set levers (32 and 33) of engine fuel shutoff valves (34 and 35) to CLSD position.

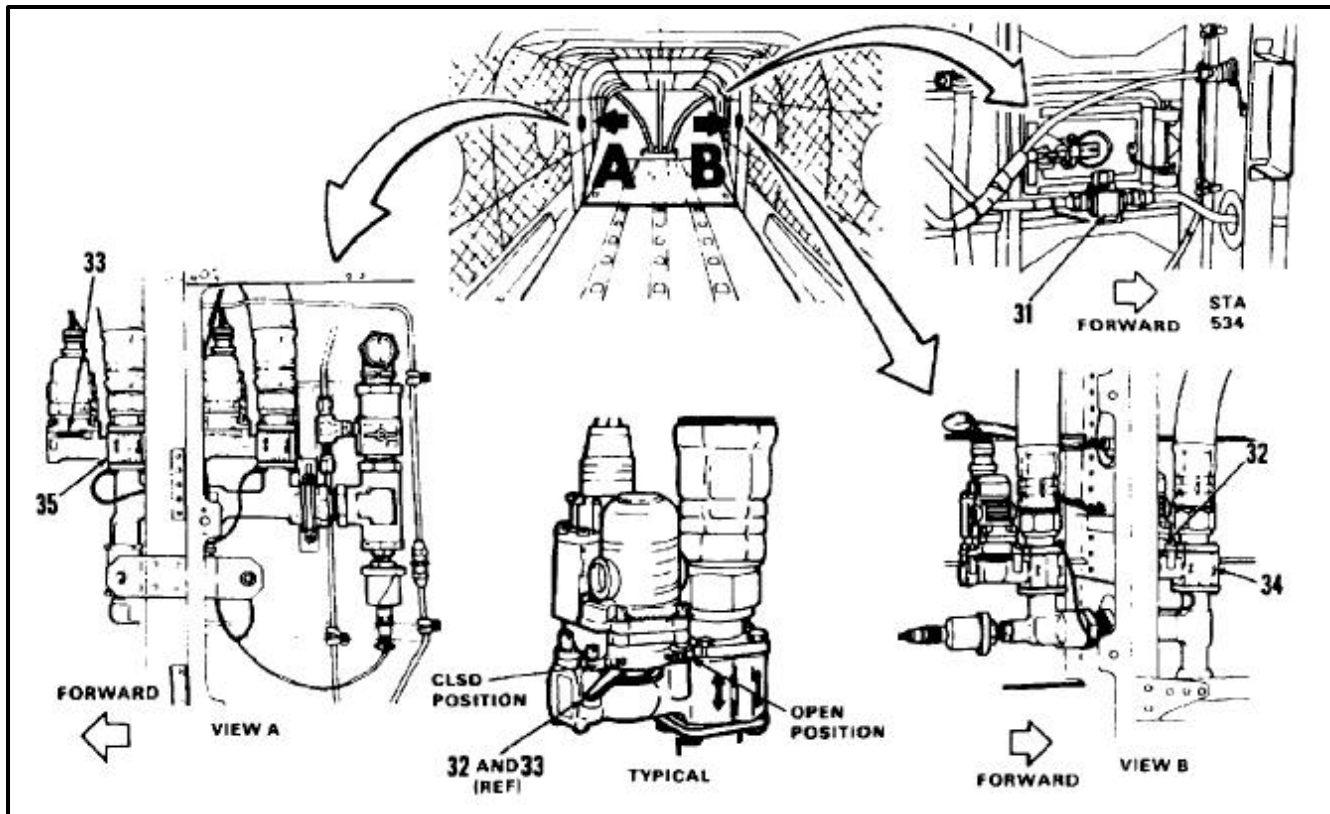

14. In cockpit set MAIN TANK FUEL PUMPS switches (36 and 37) to ON.

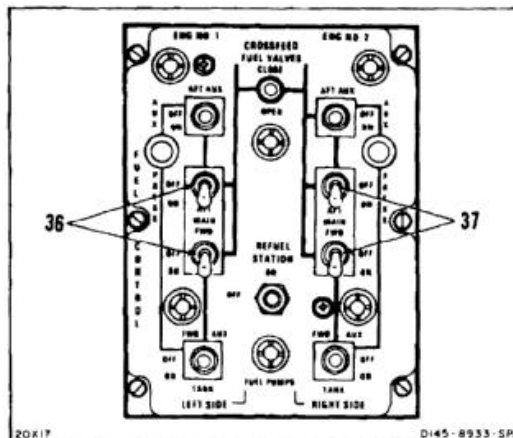

15. Manually set lever (33) of No. 2 (right) engine shutoff valve (35) to OPEN.
16. When air free stream of fuel flows from right drain hose (4), set lever (33) to CLSD position.
17. In cockpit set CROSSFEED FUEL VALVES switch (30) to OPEN.
18. Set lever (33) to OPEN position.
19. In cockpit set two RIGHT SIDE MAIN TANK FUEL PUMPS switches (37) to OFF.
20. When air free stream of fuel flows from right drain hose (4) set lever (33) to CLSD position.

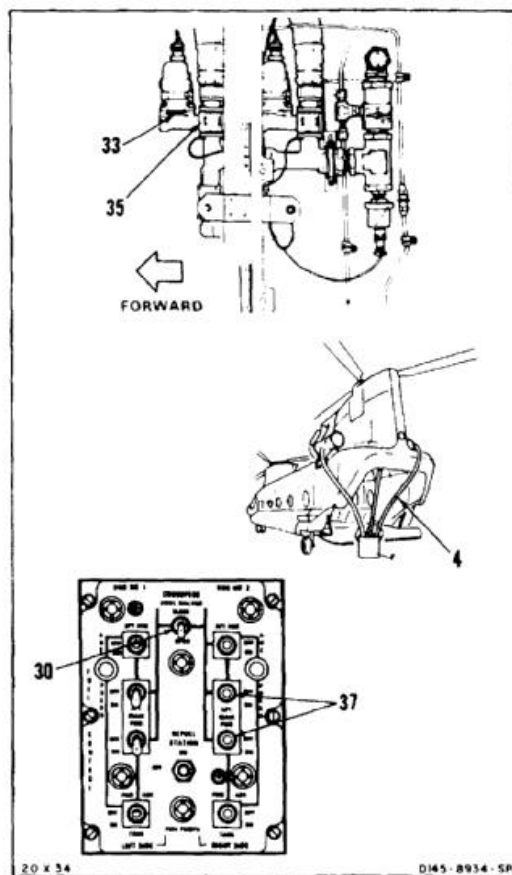

21. Set lever (32) of No. 1 (left) engine fuel shutoff valve (34) to OPEN position.
22. When air free stream of fuel flows from left drain hose (4), set lever (32) to CLSD position.
23. In cockpit set APU switch (38) to START.
24. Open APU shutoff valve (31).
25. When air free stream of fuel flows from drain hose (12), close APU shutoff valve (31).

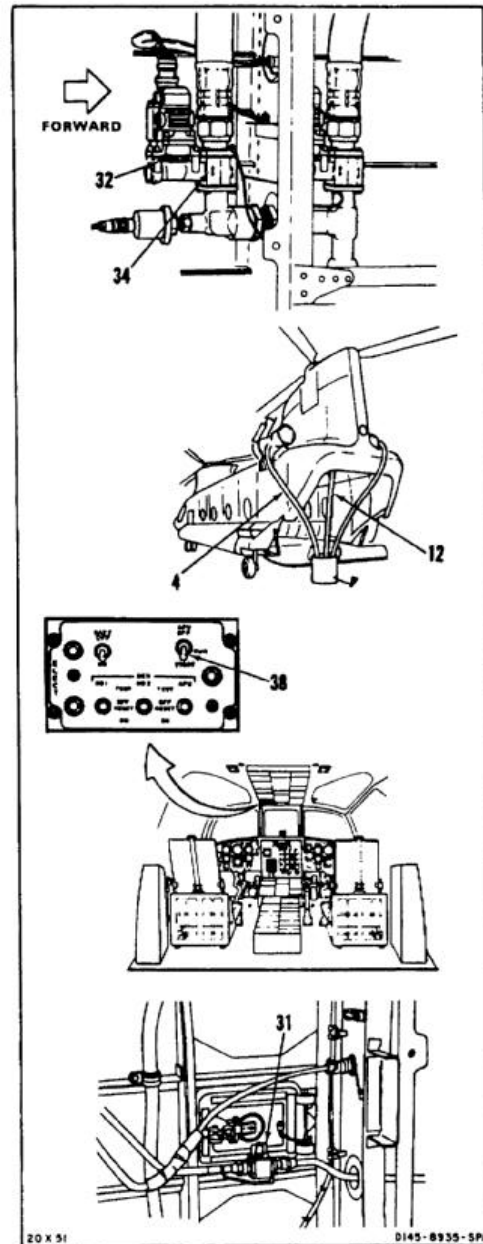

- 26. In cockpit, set two LEFT SIDE MAIN TANK FUEL PUMP switches (36) to OFF. Set APU switch (38) to OFF.

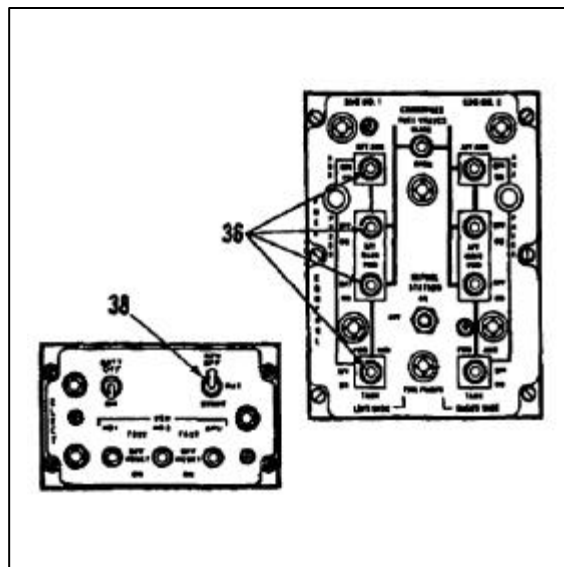

- 27. Disconnect drain hose (4) from fuel hose (1) on both engines (3).
- 28. Remove caps from nipples (2) on both engines (3). Connect fuel hoses (1) to adapters.
- 29. Remove two grounding wires (6) from container (5). Remove two drain hoses (4) from helicopter.

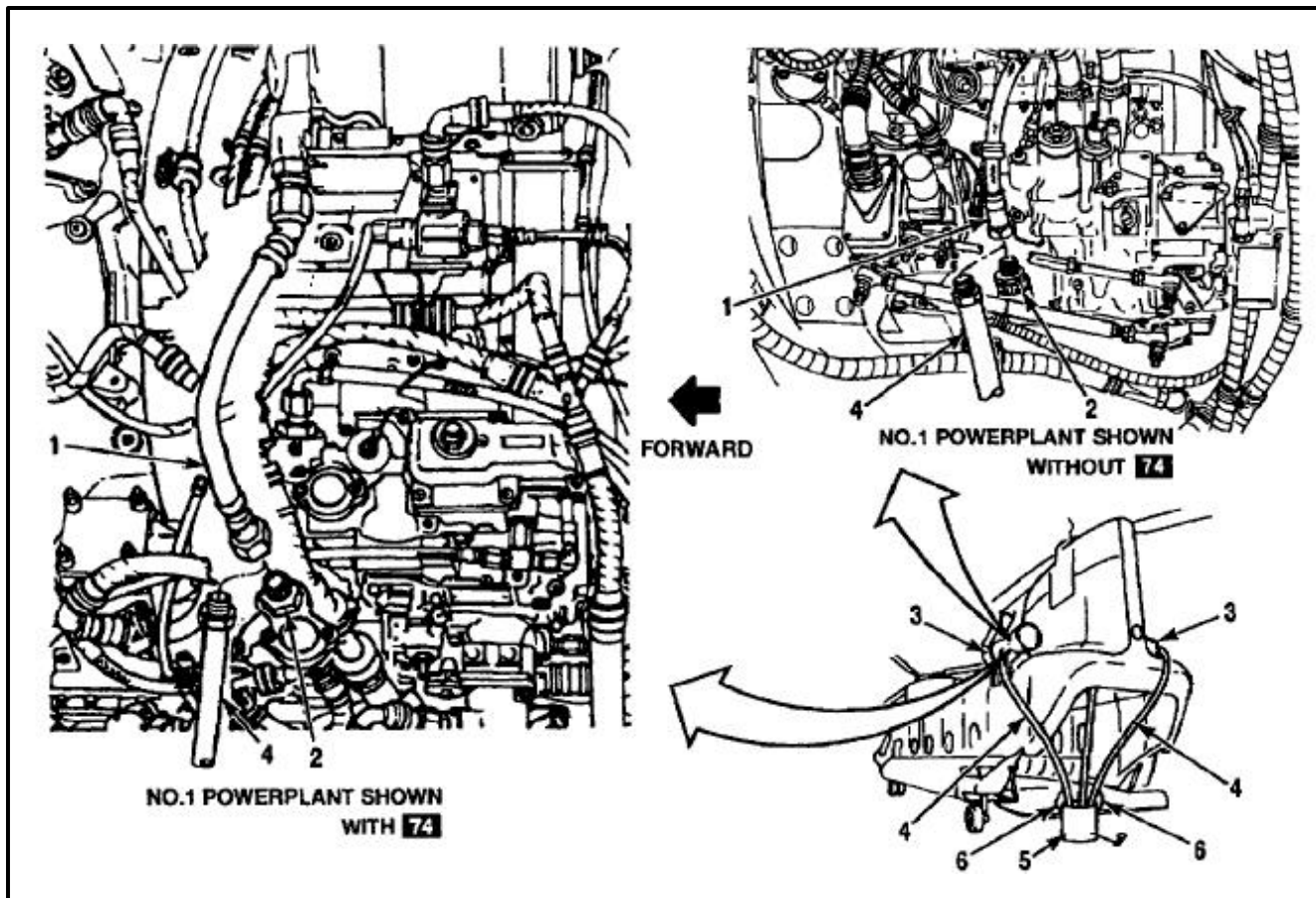

30. Disconnect drain hose (12) from fuel hose (9). Remove cap from adapter (10). Connect fuel hose to adapter.
31. Remove grounding wire (13) from container (5). Remove drain hose (12) and container from vicinity of helicopter.

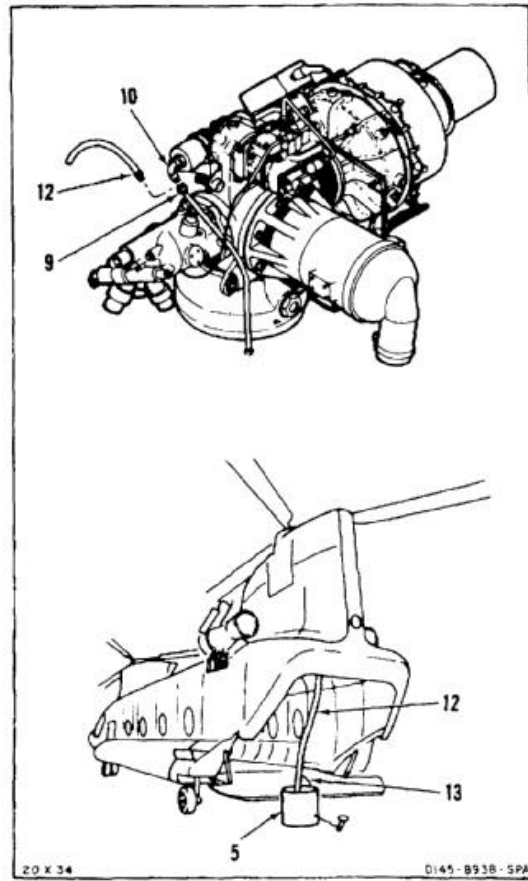

32. Open APU shutoff valve (31).

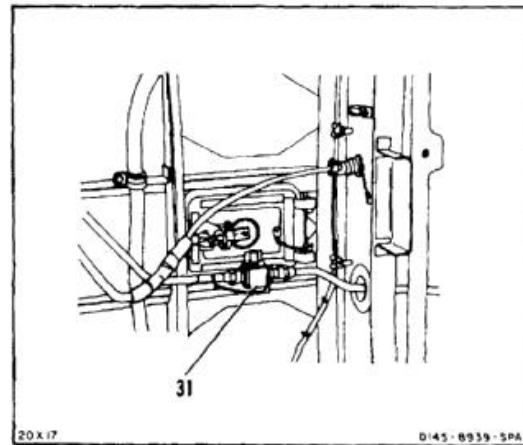

33. Manually set levers (32 and 33) of engine fuel shutoff valves (34 and 35) to OPEN position.

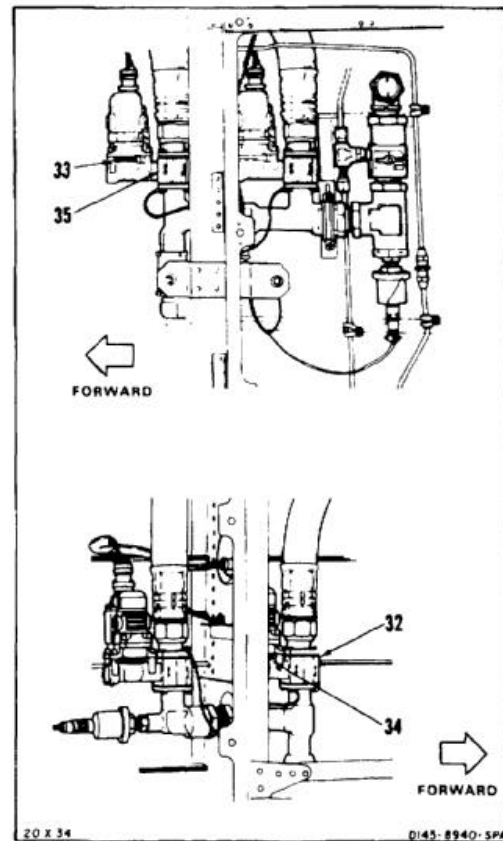

34. In cockpit set four MAIN TANK FUEL PUMP switches (36 and 37) to ON. Set APU switch (38) to START.
35. Check three fuel hose connectors, (one on each engine, one on APU) for fuel leakage.
36. In cockpit, set four MAIN TANK FUEL PUMP switches (36 and 37) to OFF. Set APU switch (38) to OFF.

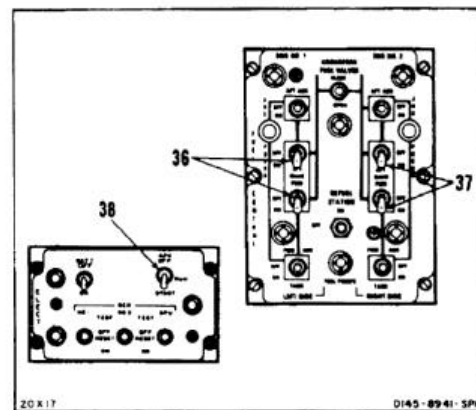

37. Connect electrical connector (7) to APU start module (8).
38. Remove ac power from helicopter (Task 1-37).
39. Clean up spilled fuel. Use cloths (E135). Wear gloves (E184.1).

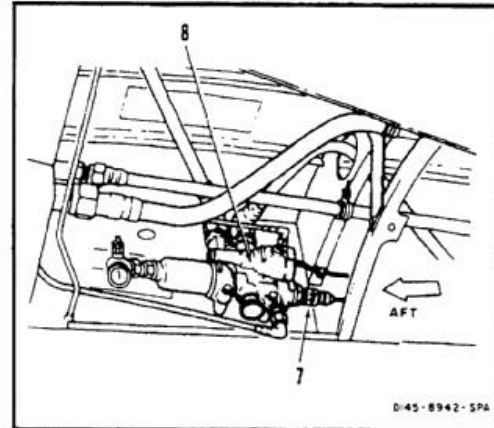
INSPECT***FOLLOW-ON MAINTENANCE:***

- Remove workstand.
- Close engine access cover (Task 4-50).
- Close engine work platform (Task 2-2).

END OF TASK

10-560

INITIAL SETUP**Applicable Configurations:**

Without **74**

Tools:

Aircraft Mechanic's Tool Kit, NSN 5180-00-323-4692
Flexible Drain Hose-Open One End, Other End No. 8
(11/16 Across Flats) Female Union, 20 Feet Long
Grounded Container, 5 Gallon or Equivalent

Materials:

Gloves (E184.1)
Cloths (E121)

Personnel Required:

Medium Helicopter Repairer (2)
Inspector

References:

Task 1-37
Task 1-38

Equipment Condition:

Helicopter Grounded (Task 1-29)
Engine Work Platform Open (Task 2-2)
Engine Access Cover Open (Task 4-49)
Apply AC Electrical Power and Hydraulic Power to
Helicopter (Tasks 1-37 and 1-38)

General Safety Instructions:**WARNING**

All regulations and instructions for handling fuels shall be strictly observed.

WARNING

Fuel is flammable and irritant to skin, eyes, and respiratory tract. Avoid repeated or prolonged skin contact. Handle only in well-ventilated areas. Keep away from sparks, open flames, or other sources of ignition.

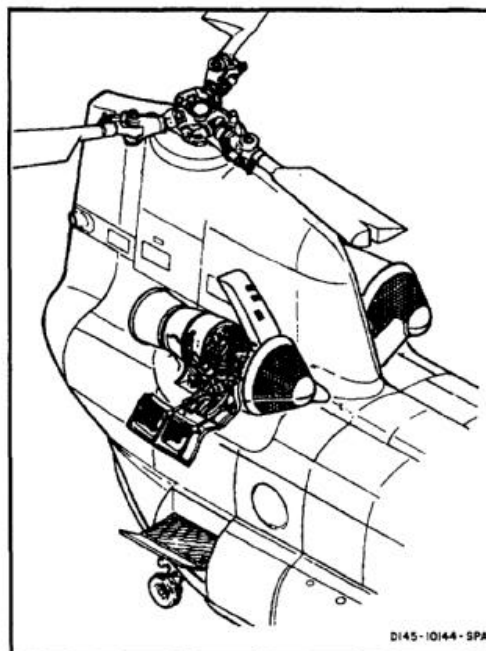

NOTE

Procedure to bleed and prime engine fuel control for No. 1 or No. 2 engine is same. Bleeding and priming of No. 2 (right) engine is shown here.

1. Open IGN circuit breaker (1) on No. 2 power distribution panel (2).

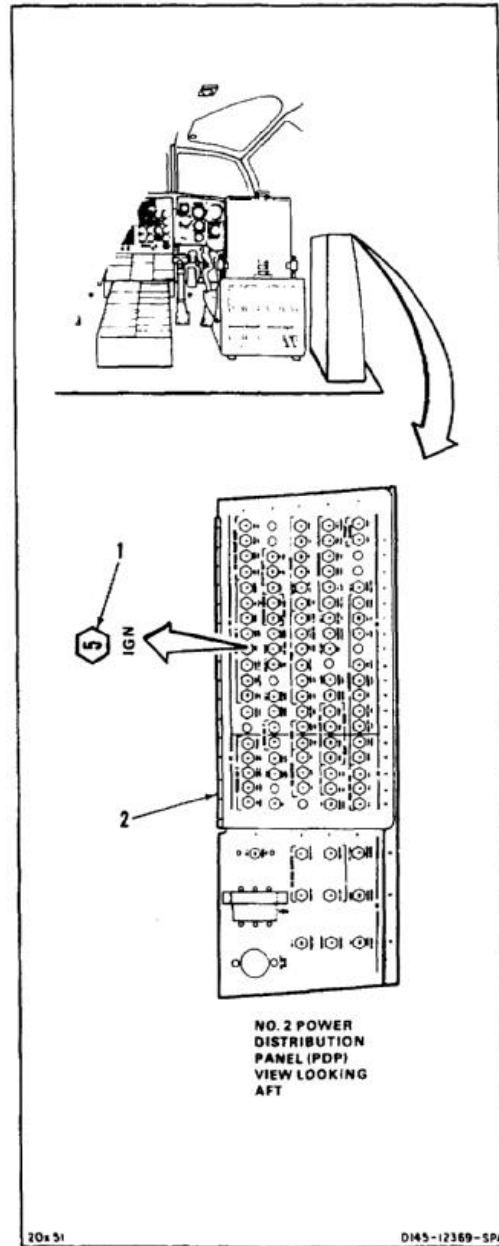

2. Disconnect hose connector (3) from oil cooler outlet (4). Wear gloves (E184.1).
3. Connect drain hose (5) to outlet (4).
4. Position free end of drain hose (5) in container (6).
5. Have helper ready to observe fuel flow from hose (5).

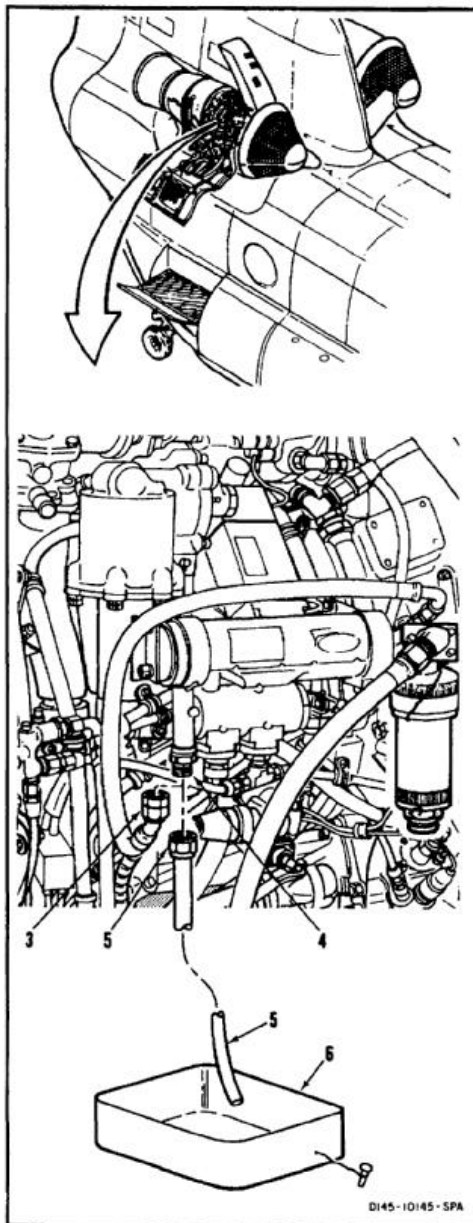

6. Set ENGINE CONDITION lever (7) to GROUND.
7. Set applicable MAIN AFT and FWD switches (8) to ON.
8. Set applicable ENGINE switch (9) to MOTOR.
9. Observe flow of fuel from hose (5) into container (6).
10. When clear, air free fuel flows from hose (5), cycle ENGINE CONDITION lever (7) from GROUND to STOP at least five times.
11. Set ENGINE CONDITION lever (7) to STOP.
12. Set ENGINE switch (9) to OFF.
13. Set MAIN AFT and FWD switches (8) to OFF.
14. Shutdown ac and hydraulic power (Tasks 1-37 and 1-38).

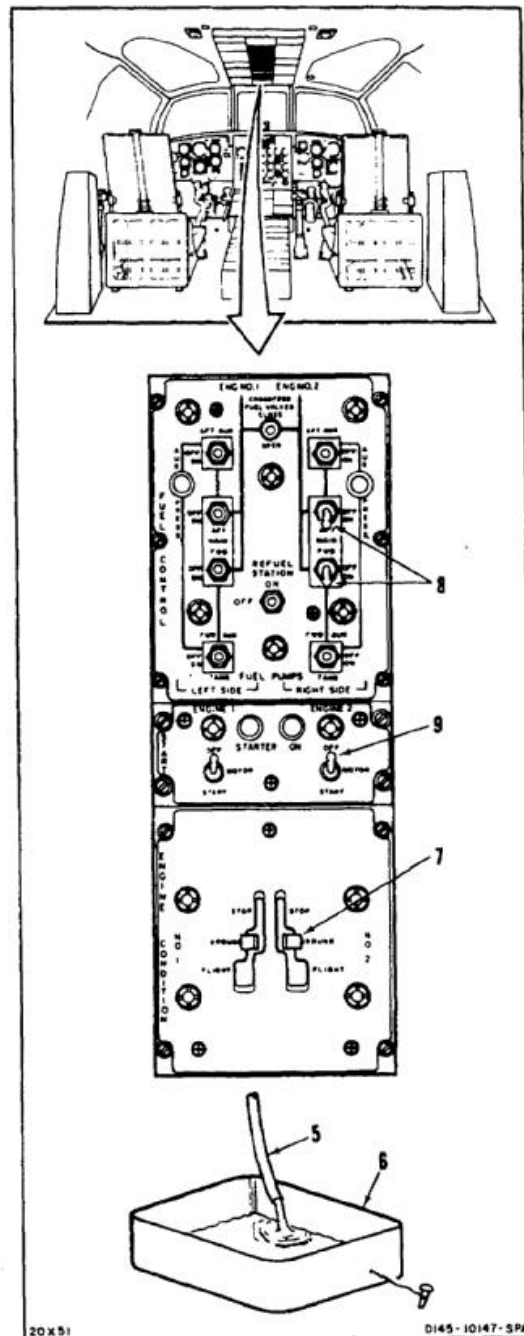

15. Close IGN circuit breaker (1) on No. 2 power distribution panel (2).

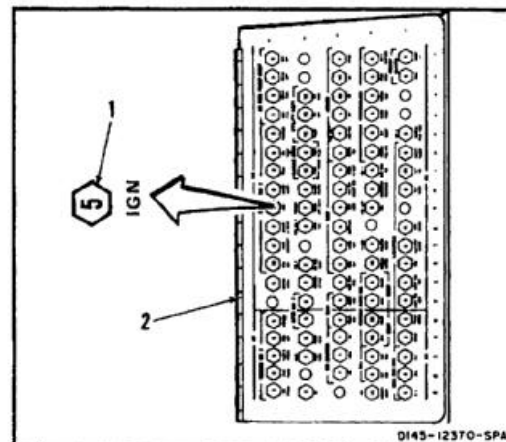

16. Disconnect defueling hose (5). Remove hose and container (6) from helicopter. Wear gloves (E184.1).
17. Connect hose connector (3) to oil cooler outlet (4).
18. Wipe up any fuel spills. Use cloths (E121). Wear gloves (E184.1).

INSPECT



After engine motoring, liquid will accumulate in the combustion chamber. The liquid must be allowed to drain before starting the engine. Otherwise, torching will occur.

FOLLOW-ON MAINTENANCE:

Remove ac electrical power and hydraulic power from helicopter (Tasks 1-37 and 1-38).
 Close engine access cover (Task 4-50).
 Close engine work platform (Task 2-2).

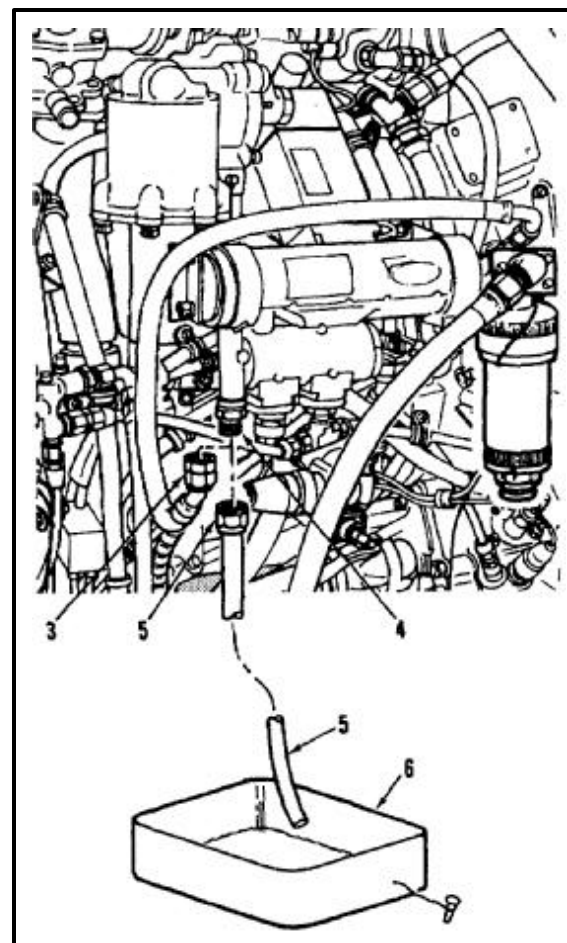

END OF TASK

By Order of the Secretary of the Army:

Official:

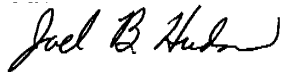

JOEL B. HUDSON
Administrative Assistant to the
Secretary of the Army
0220712

ERIC K. SHINSEKI
General, United States Army
Chief of Staff

DISTRIBUTION:

To be distributed in accordance with Initial Distribution Number (IDN) 311199, requirements for TM 55-1520-240-23-8.

These are the instructions for sending an electronic 2028

The following format must be used if submitting an electronic 2028. The subject line must be exactly the same and all fields must be included; however only the following fields are mandatory: 1, 3, 4, 5, 6, 7, 8, 9, 10, 13, 15, 16, 17, and 27.

From: "Whomever" <whomever@wherever.army.mil>

To: 2028@redstone.army.mil

Subject: DA Form 2028

1. **From:** Joe Smith
2. **Unit:** home
3. **Address:** 4300 Park
4. **City:** Hometown
5. **St:** MO
6. **Zip:** 77777
7. **Date Sent:** 19-OCT-93
8. **Pub no:** 55-2840-229-23
9. **Pub Title:** TM
10. **Publication Date:** 04-JUL-85
11. **Change Number:** 7
12. **Submitter Rank:** MSG
13. **Submitter FName:** Joe
14. **Submitter MName:** T
15. **Submitter LName:** Smith
16. **Submitter Phone:** 123-123-1234
17. **Problem:** 1
18. **Page:** 2
19. **Paragraph:** 3
20. **Line:** 4
21. **NSN:** 5
22. **Reference:** 6
23. **Figure:** 7
24. **Table:** 8
25. **Item:** 9
26. **Total:** 123
27. **Text:**

This is the text for the problem below line 27.

RECOMMENDED CHANGES TO PUBLICATIONS AND BLANK FORMS <small>For use of this form, see AR 25-30; the proponent agency is ODISC4.</small>	Use Part II (<i>reverse</i>) for Repair Parts and Special Tool Lists (RPSTL) and Supply Catalogs/Supply Manuals (SC/SM)	DATE <h2 style="text-align: center;">8/30/02</h2>
--	---	--

TO: (<i>Forward to proponent of publication or form</i>)(<i>Include ZIP Code</i>) Commander, U.S. Army Aviation and Missile Command ATTN: AMSAM-MMC-MA-NP Redstone Arsenal, 35898	FROM: (<i>Activity and location</i>)(<i>Include ZIP Code</i>) MSG, Jane Q. Doe 1234 Any Street Nowhere Town, AL 34565
--	--

PART 1 - ALL PUBLICATIONS (EXCEPT RPSTL AND SC/SM) AND BLANK FORMS

PUBLICATION/FORM NUMBER <h3 style="text-align: center;">TM 9-1005-433-24</h3>	DATE <h3 style="text-align: center;">16 Sep 2002</h3>	TITLE Organizational, Direct Support, And General Support Maintenance Manual for Machine Gun, .50 Caliber M3P and M3P Machine Gun Electrical Test Set Used On Avenger Air Defense Weapon System
--	--	---

ITEM NO.	PAGE NO.	PARA-GRAPH	LINE NO. *	FIGURE NO.	TABLE NO.	RECOMMENDED CHANGES AND REASON
1	WP0005 PG 3		2			Test or Corrective Action column should identify a different WP number. <div style="text-align: center; border: 2px solid black; padding: 50px;"> <h1 style="margin: 0;">SAMPLE</h1> </div>

* Reference to line numbers within the paragraph or subparagraph.

TYPED NAME, GRADE OR TITLE <h3 style="text-align: center;">MSG, Jane Q. Doe, SFC</h3>	TELEPHONE EXCHANGE/ AUTOVON, PLUS EXTENSION <h3 style="text-align: center;">788-1234</h3>	SIGNATURE
--	---	-----------

TO: (Forward direct to addressee listed in publication) Commander, U.S. Army Aviation and Missile Command ATTN: AMSAM-MMC-MA-NP Redstone Arsenal, 35898	FROM: (Activity and location) (Include ZIP Code) MSG, Jane Q. Doe 1234 Any Street Nowhere Town, AL 34565	DATE 8/30/02
---	--	------------------------

PART II - REPAIR PARTS AND SPECIAL TOOL LISTS AND SUPPLY CATALOGS/SUPPLY MANUALS

PUBLICATION NUMBER			DATE	TITLE				
PAGE NO.	COLM NO.	LINE NO.	NATIONAL STOCK NUMBER	REFERENCE NO.	FIGURE NO.	ITEM NO.	TOTAL NO. OF MAJOR ITEMS SUPPORTED	RECOMMENDED ACTION
SAMPLE								

PART III - REMARKS (Any general remarks or recommendations, or suggestions for improvement of publications and blank forms. Additional blank sheets may be used if more space is needed.)

TYPED NAME, GRADE OR TITLE MSG, Jane Q. Doe, SFC	TELEPHONE EXCHANGE/AUTOVON, PLUS EXTENSION 788-1234	SIGNATURE
---	---	-----------

RECOMMENDED CHANGES TO PUBLICATIONS AND BLANK FORMS <small>For use of this form, see AR 25-30; the proponent agency is ODISC4.</small>	Use Part II (reverse) for Repair Parts and Special Tool Lists (RPSTL) and Supply Catalogs/Supply Manuals (SC/SM)	DATE
--	--	------

TO: (Forward to proponent of publication or form)(Include ZIP Code)	FROM: (Activity and location)(Include ZIP Code)
---	---

PART 1 - ALL PUBLICATIONS (EXCEPT RPSTL AND SC/SM) AND BLANK FORMS

PUBLICATION/FORM NUMBER TM 9-1005-433-24	DATE 16 Sep 2002	TITLE Organizational, Direct Support, And General Support Maintenance Manual for Machine Gun, .50 Caliber M3P and M3P Machine Gun Electrical Test Set Used On Avenger Air Defense Weapon System
--	----------------------------	---

ITEM NO.	PAGE NO.	PARA-GRAPH	LINE NO. *	FIGURE NO.	TABLE NO.	RECOMMENDED CHANGES AND REASON

** Reference to line numbers within the paragraph or subparagraph.*

TYPED NAME, GRADE OR TITLE	TELEPHONE EXCHANGE/ AUTOVON, PLUS EXTENSION	SIGNATURE
----------------------------	--	-----------

TO: (Forward direct to addressee listed in publication)	FROM: (Activity and location) (Include ZIP Code)	DATE
--	---	-------------

PART II - REPAIR PARTS AND SPECIAL TOOL LISTS AND SUPPLY CATALOGS/SUPPLY MANUALS

PUBLICATION NUMBER	DATE	TITLE
---------------------------	-------------	--------------

PAGE NO.	COLM NO.	LINE NO.	NATIONAL STOCK NUMBER	REFERENCE NO.	FIGURE NO.	ITEM NO.	TOTAL NO. OF MAJOR ITEMS SUPPORTED	RECOMMENDED ACTION

PART III - REMARKS (Any general remarks or recommendations, or suggestions for improvement of publications and blank forms. Additional blank sheets may be used if more space is needed.)

--

TYPED NAME, GRADE OR TITLE	TELEPHONE EXCHANGE/AUTOVON, PLUS EXTENSION	SIGNATURE
----------------------------	--	-----------

The Metric System and Equivalents

Linear Measure

1 centimeter = 10 millimeters = .39 inch
 1 decimeter = 10 centimeters = 3.94 inches
 1 meter = 10 decimeters = 39.37 inches
 1 dekameter = 10 meters = 32.8 feet
 1 hectometer = 10 dekameters = 328.08 feet
 1 kilometer = 10 hectometers = 3,280.8 feet

Weights

1 centigram = 10 milligrams = .15 grain
 1 decigram = 10 centigrams = 1.54 grains
 1 gram = 10 decigrams = .035 ounce
 1 decagram = 10 grams = .35 ounce
 1 hectogram = 10 decagrams = 3.52 ounces
 1 kilogram = 10 hectograms = 2.2 pounds
 1 quintal = 100 kilograms = 220.46 pounds
 1 metric ton = 10 quintals = 1.1 short tons

Liquid Measure

1 centiliter = 10 milliliters = .34 fl. ounce
 1 deciliter = 10 centiliters = 3.38 fl. ounces
 1 liter = 10 deciliters = 33.81 fl. ounces
 1 dekaliter = 10 liters = 2.64 gallons
 1 hectoliter = 10 dekaliters = 26.42 gallons
 1 kiloliter = 10 hectoliters = 264.18 gallons

Square Measure

1 sq. centimeter = 100 sq. millimeters = .155 sq. inch
 1 sq. decimeter = 100 sq. centimeters = 15.5 sq. inches
 1 sq. meter (centare) = 100 sq. decimeters = 10.76 sq. feet
 1 sq. dekameter (are) = 100 sq. meters = 1,076.4 sq. feet
 1 sq. hectometer (hectare) = 100 sq. dekameters = 2.47 acres
 1 sq. kilometer = 100 sq. hectometers = .386 sq. mile

Cubic Measure

1 cu. centimeter = 1000 cu. millimeters = .06 cu. inch
 1 cu. decimeter = 1000 cu. centimeters = 61.02 cu. inches
 1 cu. meter = 1000 cu. decimeters = 35.31 cu. feet

Approximate Conversion Factors

<i>To change</i>	<i>To</i>	<i>Multiply by</i>	<i>To change</i>	<i>To</i>	<i>Multiply by</i>
inches	centimeters	2.540	ounce-inches	Newton-meters	.007062
feet	meters	.305	centimeters	inches	.394
yards	meters	.914	meters	feet	3.280
miles	kilometers	1.609	meters	yards	1.094
square inches	square centimeters	6.451	kilometers	miles	.621
square feet	square meters	.093	square centimeters	square inches	.155
square yards	square meters	.836	square meters	square feet	10.764
square miles	square kilometers	2.590	square meters	square yards	1.196
acres	square hectometers	.405	square kilometers	square miles	.386
cubic feet	cubic meters	.028	square hectometers	acres	2.471
cubic yards	cubic meters	.765	cubic meters	cubic feet	35.315
fluid ounces	milliliters	29.573	cubic meters	cubic yards	1.308
pints	liters	.473	milliliters	fluid ounces	.034
quarts	liters	.946	liters	pints	2.113
gallons	liters	3.785	liters	quarts	1.057
ounces	grams	28.349	liters	gallons	.264
pounds	kilograms	.454	grams	ounces	.035
short tons	metric tons	.907	kilograms	pounds	2.205
pound-feet	Newton-meters	1.356	metric tons	short tons	1.102
pound-inches	Newton-meters	.11296			

Temperature (Exact)

F	Fahrenheit temperature	5/9 (after subtracting 32)	Celsius temperature	C
---	---------------------------	-------------------------------	------------------------	---

